



# SWIPBOX® INFINITY

## TECHNICAL SPECIFICATION





# ONE PLATFORM. INFINITE POSSIBILITIES.

**SwipBox Infinity**, SwipBox's flagship lean locker, communicates via Bluetooth, runs on a battery and is fully app operated from configuration to installation and parcel pickup. This lean version is ideal for markets that are digitally mature and carriers who are looking for a locker solution with minimum maintenance.

**SwipBox Infinity Flex and SwipBox Infinity Connect** build on the Infinity platform's lean-locker foundation. Both models are battery-powered and Bluetooth-enabled and may be fully app-operated.

Infinity Flex combines app control with a built-in PIN pad or screen interface, while Infinity Connect pairs app control with a standalone screen module for PIN code entry. This flexibility allows you to match each installation to user preferences and location needs without deploying multiple locker systems.

# SWIPBOX INFINITY MODELS

14 COMPARTMENTS

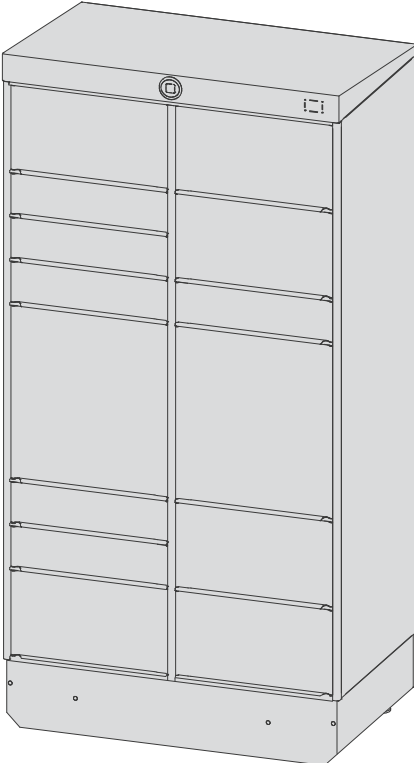

16 COMPARTMENTS

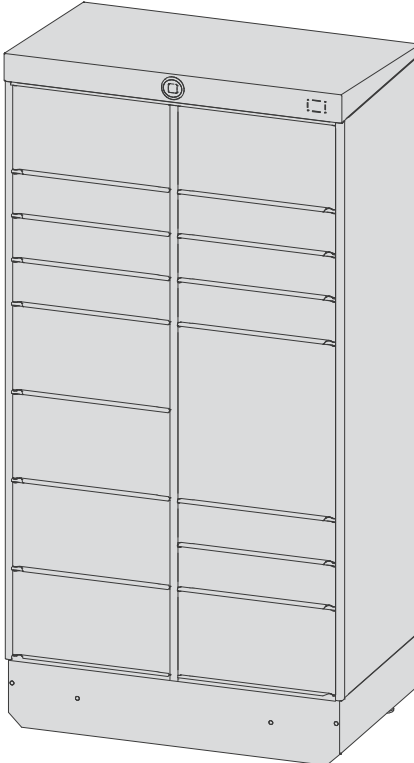

20 COMPARTMENTS

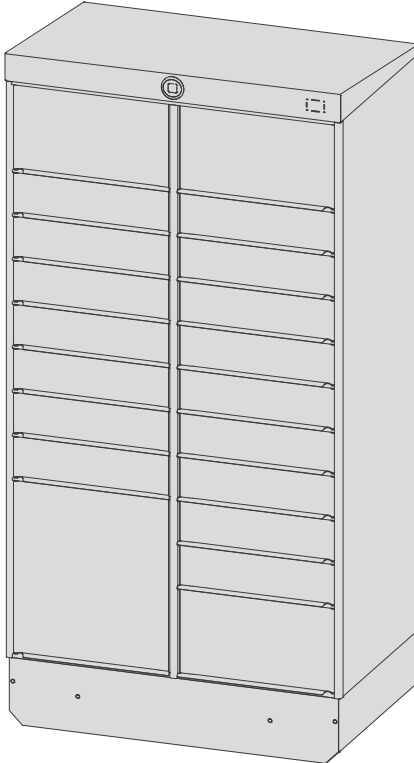

**22 COMPARTMENTS**

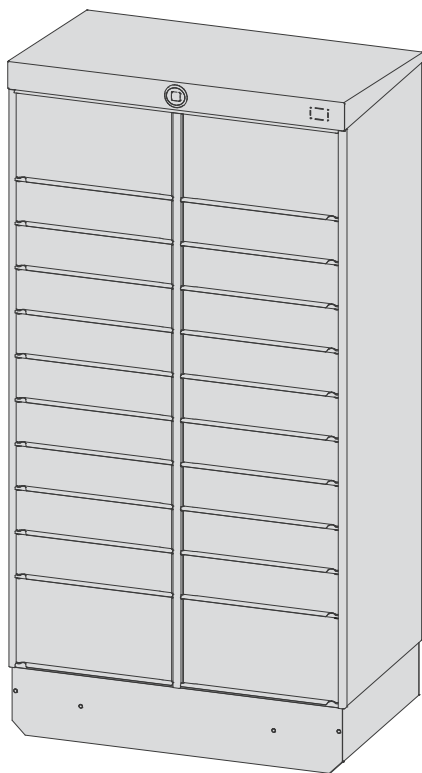

**32 COMPARTMENTS**

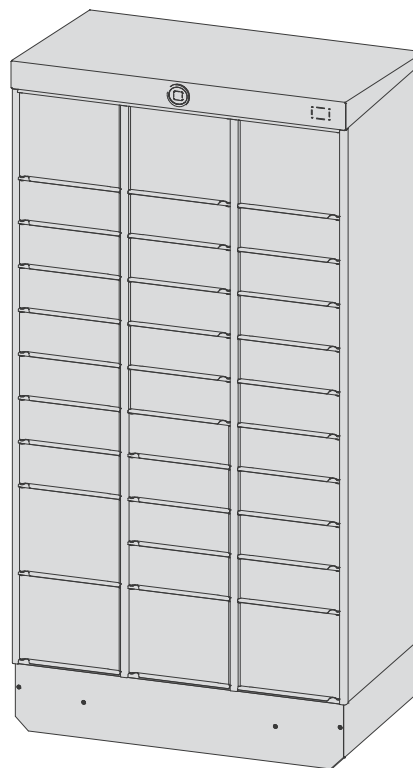

# SWIPBOX INFINITY FLEX 10

28 COMPARTMENTS WITH A 10" SCREEN MODULE

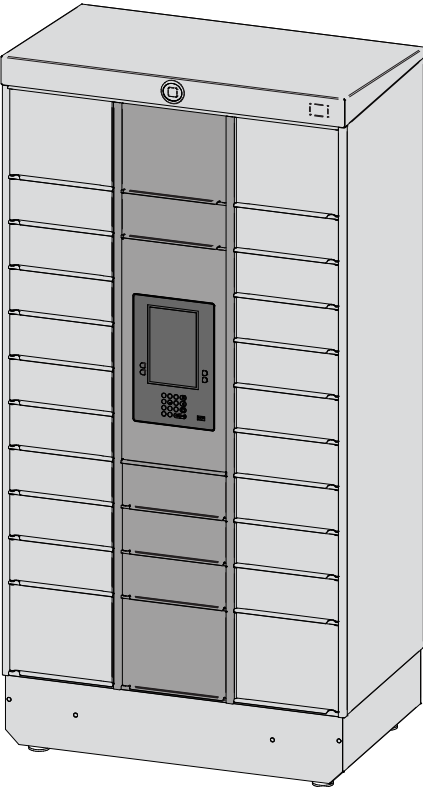

# SWIPBOX INFINITY CONNECT 10

## STANDALONE BUILT-IN 10" SCREEN MODULE

Combine with any Infinity model

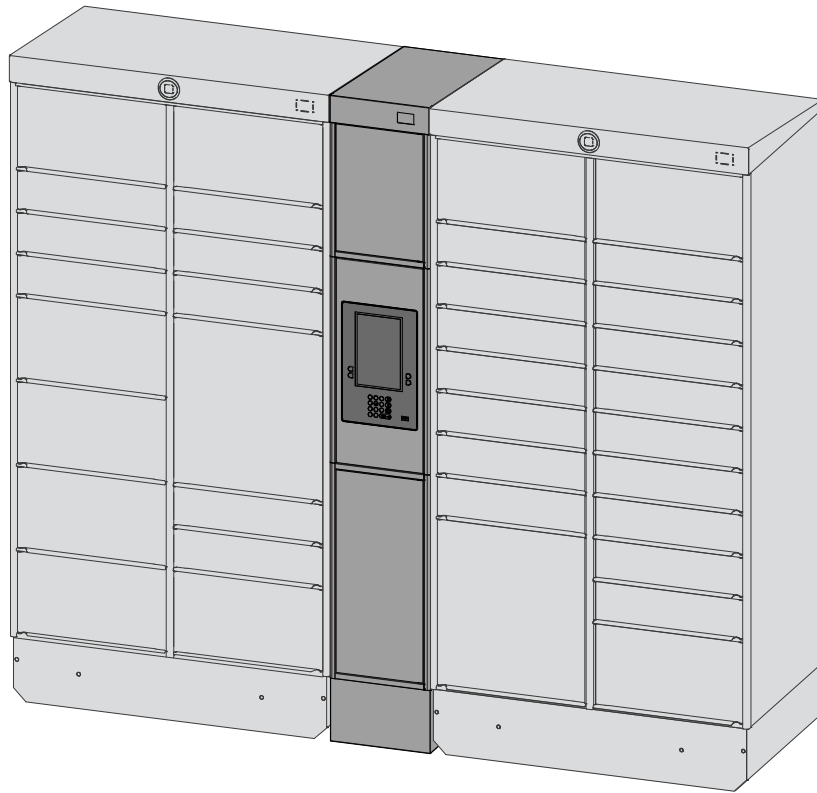
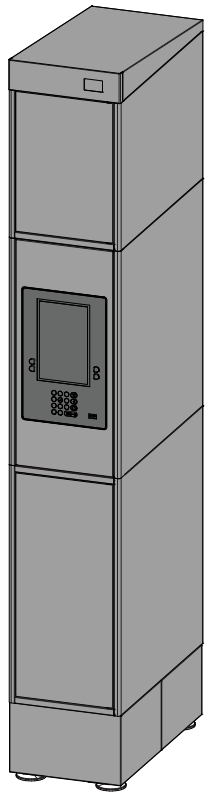

Sample setup

# MEASUREMENTS AND WEIGHT

Indoor and outdoor models - Infinity and Infinity Flex

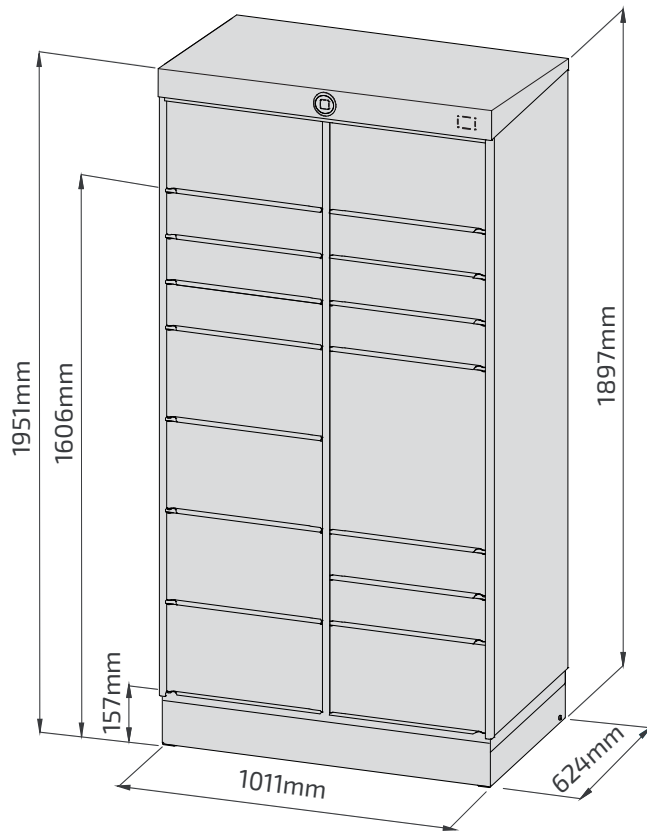

## INDOOR

Weight

14 + 16 compartments	130kg
20 + 22 compartments	160kg
32 compartments	196kg

Outer dimensions are the same for all models

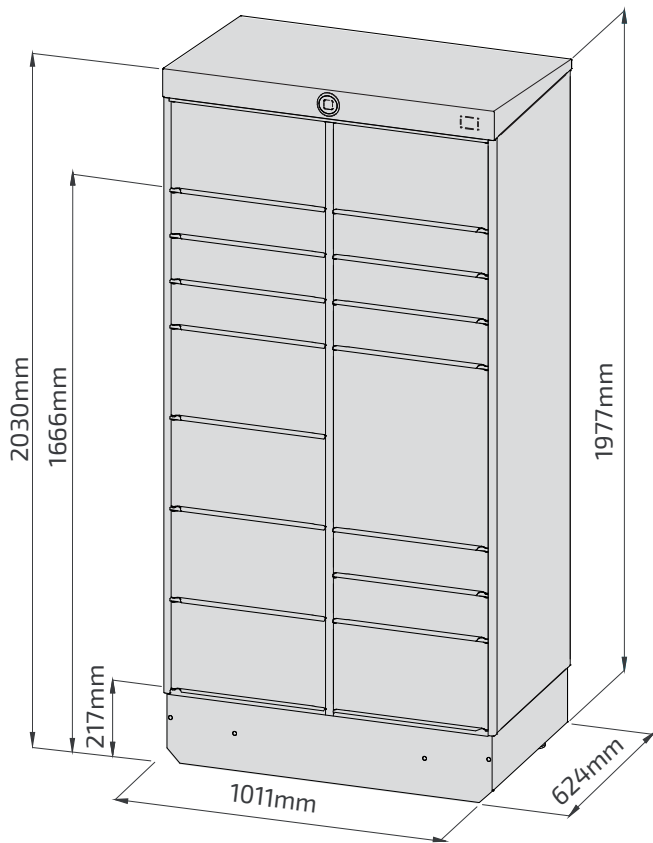

Outer dimensions are the same for all models

## OUTDOOR

Weight

14 + 16 compartments	300kg
20 + 22 compartments	330kg
28 compartments*	366kg**
32 compartments	366kg

\*Infinity Flex 10

\*\*Additional battery weight 2x7kg



# MEASUREMENTS AND WEIGHT

Outdoor model - Connect 10

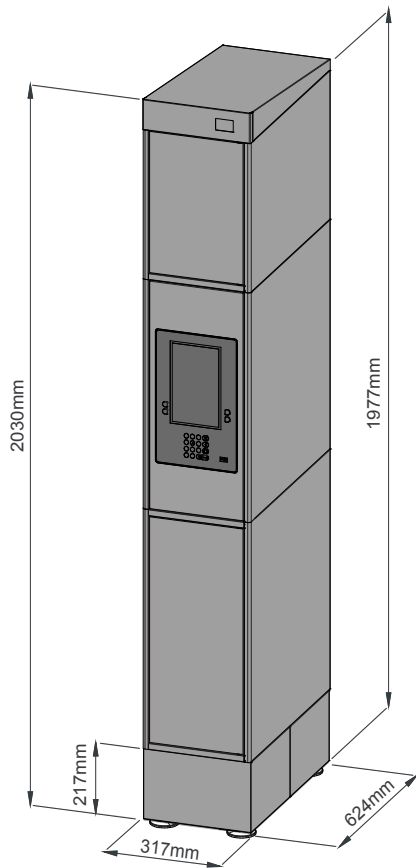

## WEIGHT

Outdoor	75kg*
---------	-------

\*Additional battery weight 2x7kg

# COMPARTMENT SIZES

## Measurements

	<b>Small</b> (HxWxD) 110x440x590mm	<b>Medium</b> (HxWxD) 240x440x590mm	<b>Large</b> (HxWxD) 500x440x590mm
<b>14 compartments</b>	6	6	2
<b>16 compartments</b>	8	7	1
<b>20 compartments</b>	16	3	1
<b>22 compartments</b>	18	4	-
	<b>Small slim</b> (HxWxD) 110x270x590mm	<b>Medium slim</b> (HxWxD) 240x270x590mm	
<b>32 compartments</b>	25	7	
<b>28 compartments *</b>	22	6	

\*Infinity Flex 10





# TECHNICAL INFORMATION (INFINITY)

Materials and operational data

<b>Power input</b>	Battery operated. Min. lifespan of 10 years
<b>Bluetooth® communication range</b>	3m from the parcel locker
<b>Storage/transport temp.</b>	-20°C to +50°C
<b>Operating temp.</b>	-20°C to +50°C
<b>Operating humidity max.</b>	95% (non-condensing)
<b>Max. weight on shelf</b>	32kg
<b>Paint</b>	Powder coating
<b>Material</b>	Aluminium and galvanised sheet metal

# SWIPBOX INFINITY FLEX PIN

14 COMPARTMENTS

16 COMPARTMENTS

20 COMPARTMENTS



**Wheelchair accessibility:** All interactive elements are placed at a height between 380-1220mm as dictated by the EN-301 549 standard.

**22 COMPARTMENTS**



**32 COMPARTMENTS**



# TECHNICAL INFORMATION (PIN PAD)

Materials and operational data

<b>Power input</b>	Battery operated. Lifespan of 5 years*
<b>Storage/transport temp.</b>	-20°C to +50°C
<b>Operating temp.</b>	-20°C to +50°C
<b>Operating humidity max.</b>	95% (non-condensing)
<b>Material</b>	Plastic
<b>Max. view angle (display)</b>	80 degrees
<b>Button backlight</b>	Yes
<b>Modem</b>	LTE-M modem w. nano SIM card

\*Based on standard firmware with 4 periodic synchronisations and 24 transactions per day. Battery lifetime will depend on usage pattern, firmware configuration and connectivity.

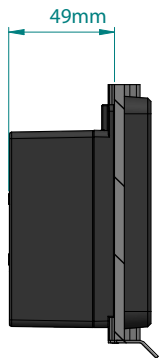
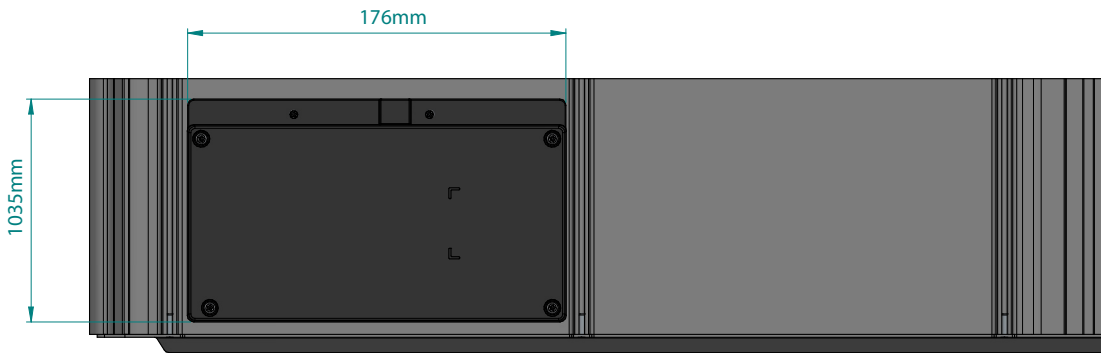
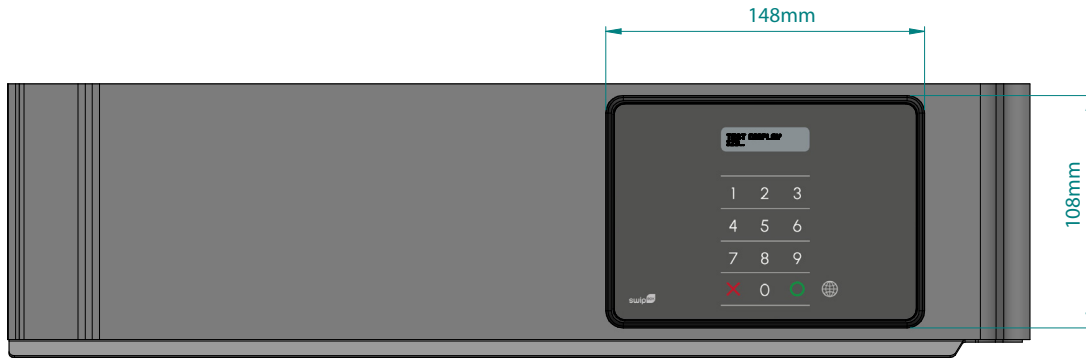

# TECHNICAL INFORMATION (SCREEN SECTION)

Materials and operational data

## SCREEN MODULE

Power input	Battery operated. Min. lifespan of 2 years*
Storage/transport temp.	-20°C to +50°C
Operating temp.	-20°C to +50°C
Operating humidity max.	95% (non-condensing)
Screen resolution	1280px x 800px
Viewing angle	Free
Button backlight	Yes
Modem	LTE Cat-1 bis modem w. nano SIM card and SoftSIM capabilities
Loudspeaker	Built in
Scanner	Built in
NFC	Prepared for NFC functionality

\*Battery lifetime will depend on usage pattern.

## SCREEN CABINET

Material	Galvanised sheet metal, powder coated
----------	---------------------------------------



**Match your customers' needs.** Today's customers expect fast delivery and flexible pickup options. Infinity offers multiple interface choices – app, PIN pad or screen – so you can select the solution that fits your users.

**Adapt your network with ease.** From small parcels to mixed sizes, Infinity models fit your operation. Fast installation means you can scale, relocate or respond quickly to changing customer needs.

**Keep costs low with a lean design.** Infinity's ultra-low energy consumption means that over 10 years, it uses the equivalent of a hairdryer running for just 7 minutes. A minimal mechanical design reduces maintenance needs, repair costs, and part replacements, helping you lower both operational expenses and environmental impact.



**SwipBox International A/S**

Ellegaardvej 7

DK-6400 Sonderborg

[international@swipbox.com](mailto:international@swipbox.com)

[www.swipbox.com](http://www.swipbox.com)

**Version 2 2025**

SwipBox, SwipBox Infinity, SwipBox Classic and SwipBox Circuit are trademarks and copyrights of SwipBox International A/S.  
©2025 SwipBox International A/S. All rights reserved.