

Adjoin™

ADAPTIVE PANEL SYSTEM

Divide and unite.
Divide and unite.
Divide and unite.
Divide and unite.
Divide and unite.

Workstation Partitions

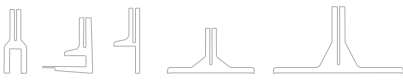
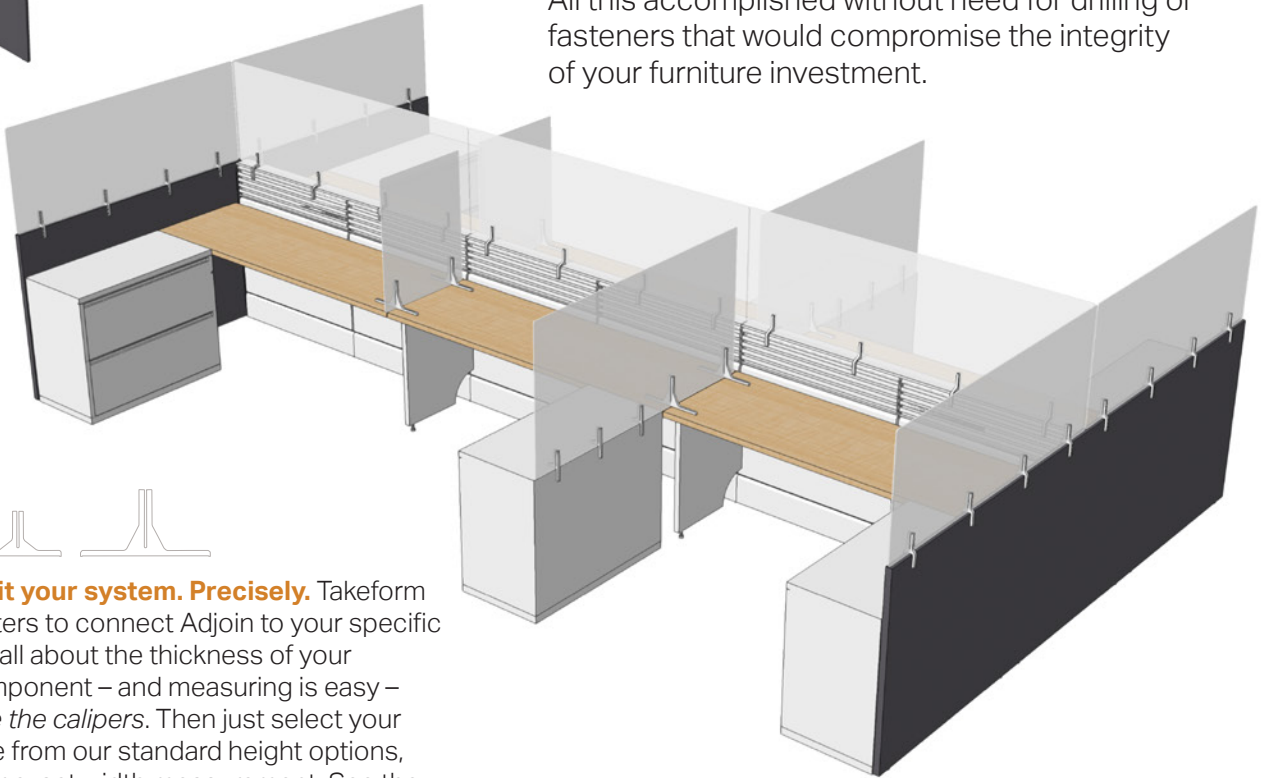
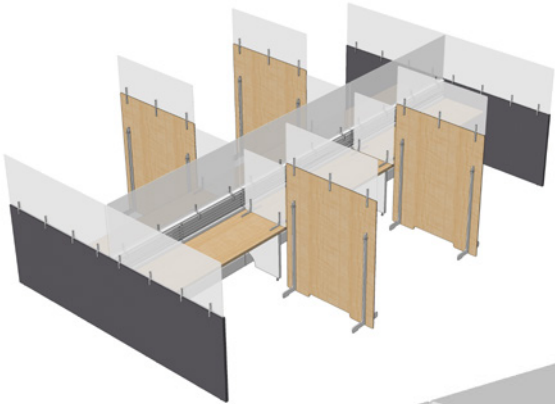

Our Adapters fit your system. Precisely. Takeform engineers adapters to connect Adjoin to your specific workstation. It's all about the thickness of your workstation component – and measuring is easy – *we even provide the calipers*. Then just select your material, choose from our standard height options, and specify your exact width measurement. See the next page for simple step-by-step instructions.

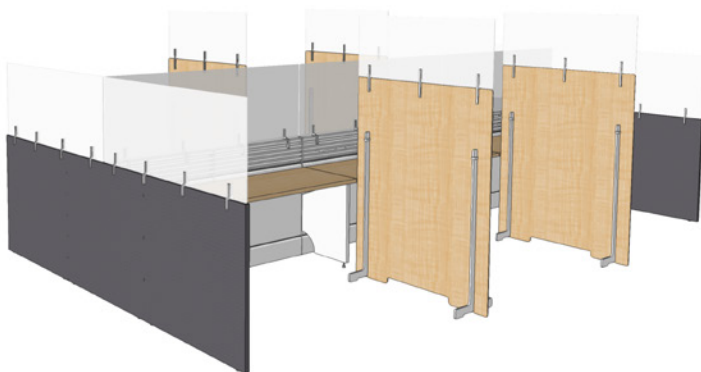

Adjoin is the creative panel system that fits almost every workspace scenario.

Add cleanable protection, privacy, and style to nearly any modular workstation system, bench-style desking, or floor space with Adjoin. It's the system designed to easily integrate with furniture systems or accommodate almost any freestanding installation. Select materials or finishes to complement your space or brand. You can even specify custom graphics for added brand presence. All this accomplished without need for drilling or fasteners that would compromise the integrity of your furniture investment.

Function, cleanability, and design work side-by-side.

Specify Adjoin to add protection that stands up to effective disinfecting products while providing the aesthetic sensitivity that enhances your space for the long term.

15-second self-install

Adjoin protects your budget and schedule.

Save time and significant installation costs. Adjoin's adapter system makes installation nearly effortless. Just lift the panel and slide the stacker on your workstation. Done.

takeform

Step 1: Specify workstation application for each panel*

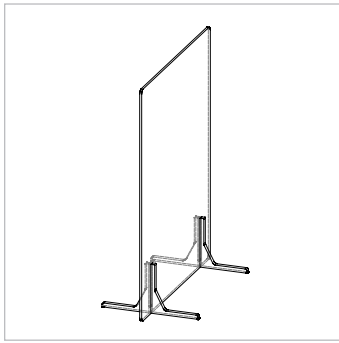

1. Freestanding desktop

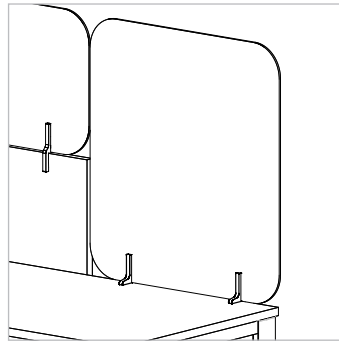

2. Adapter-mounted desktop

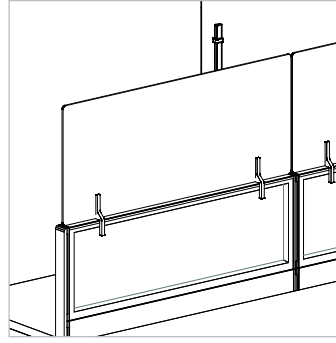

3. Panel stacker

* Please provide in situ photo(s) of workstation(s) for engineering reference.

Step 2: Select leg/adaptor color



1. Black

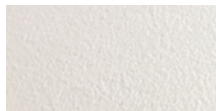

2. White

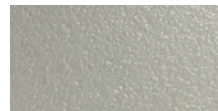

3. Gray

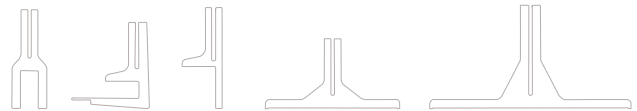

Step 3: Specify panel dimensions

Workstation/Desk stacker/partition sizing

1. **11" panel height** (exact width can be specified from 16"w - 95"w)
2. **15" panel height** (exact width can be specified from 16"w - 95"w)
3. **18" panel height** (exact width can be specified from 16"w - 95"w)
4. **23.5" panel height** (exact width can be specified from 16"w - 95"w)



Thickness measurement:
We'll ship you free calipers and instructions. Just fit caliper to the edge of your workstation component and send us a photo of the caliper in position so we can read the measurement.

Step 4: Specify material

1. **Aluminum Composite Material (ACM/Moxie)** with optional direct-print graphics (Moxie)
2. **Acrylic** clear or frosted
3. **High pressure laminate**
4. **Magnetic**

Step 5: Graphics for Moxie (ACM) panels (optional)

Select from our standard patterns (see pages 5-8) or collaborate with Takeform design team to create custom graphics for your Adjoin panels.



takeform.net

800.528.1398

Specifications

Size to fit

- Adjoin adapters fit any rigid commercial-grade workstation
- Simple measuring process precisely retrofits Adjoin to workstation
- Four standard stacker heights add desired level of protection/privacy to workstations (11", 15", 18", 23.5")
- Manufactured to the width of your furniture up to 95"
- Four standard freestanding partition sizes available

Cleanable materials

- All material options provide smooth cleanable surfaces for easy disinfecting with effective cleaning agents, *including bleach*.
- Specify material to complement furniture, space, or brand:
 - ACM(Moxie) with optional printing
 - Clear and frosted acrylic
 - High pressure laminate
 - Magnetic (black or white)

- Transparent-to-opaque: a full opacity range for desired level of light filtering/privacy
- Specify adapters/legs in black, white, or gray
- Direct print graphics for added creative potential. (ACM)

Custom shapes

- Standard half-inch corner radius spec provides maximum protection
- Specify the four-inch corner radius to complement the aesthetic of your furniture or space
- Optional top-edge shaping: angle, curve, wave, etc. to reflect the architectural line of your space or other design cue

Simple installation

- Flat pack shippable
- Assembles in field with minimal/no tools
- Non-destructive retrofit attachment methods for most workstations
- Two leg design options for freestanding partitions

Important Considerations: Pricing is significantly effected by material yield

- For 48" wide to 63" wide panels, consider specifying two panels for better value (i.e., two 30" panels instead of one 60").
- For 48" w spaces, guide customers to order 47.5". That half-inch width adjustment will reduce cost significantly.
- For customers asking for 18" high, suggest 15" for better value (compare below).

Pricing for Standard Panel Sizes

11" high

| Dimension | Moxie White Matte | Moxie Graphic Panel | HPL Tier 1 Laminate | Clear Acrylic | Frosted Acrylic | Magnetic White | Magnetic Black |
|-------------|-------------------|---------------------|---------------------|---------------|-----------------|----------------|----------------|
| 11" x 23.5" | \$37.36 | \$41.09 | \$54.47 | \$58.75 | \$62.38 | \$130.22 | \$146.62 |
| 11" x 30" | \$46.48 | \$51.45 | \$69.29 | \$75.00 | \$79.83 | \$170.29 | \$192.16 |
| 11" x 36" | \$64.72 | \$72.18 | \$98.94 | \$107.50 | \$114.75 | \$250.44 | \$283.24 |
| 11" x 42" | \$69.72 | \$77.18 | \$103.94 | \$112.50 | \$119.75 | \$255.44 | \$288.24 |
| 11" x 47.5" | \$69.72 | \$77.18 | \$103.94 | \$112.50 | \$119.75 | \$255.44 | \$288.24 |
| 11" x 54" | \$124.44 | \$139.35 | \$192.88 | \$210.00 | \$224.50 | \$495.88 | \$561.48 |
| 11" x 60" | \$124.44 | \$139.35 | \$192.88 | \$210.00 | \$224.50 | \$495.88 | \$561.48 |
| 11" x 66"+ | \$129.44 | \$144.35 | \$197.88 | \$215.00 | \$229.50 | \$500.88 | \$566.48 |

15" high

| Dimension | Moxie White Matte | Moxie Graphic Panel | HPL Tier 1 Laminate | Clear Acrylic | Frosted Acrylic | Magnetic White | Magnetic Black |
|-------------|-------------------|---------------------|---------------------|---------------|-----------------|----------------|----------------|
| 15" x 23.5" | \$46.48 | \$51.45 | \$69.29 | \$75.00 | \$79.83 | \$170.29 | \$192.16 |
| 15" x 30" | \$58.64 | \$65.27 | \$89.06 | \$96.67 | \$103.11 | \$223.72 | \$252.88 |
| 15" x 36" | \$82.96 | \$92.90 | \$128.58 | \$140.00 | \$149.67 | \$330.58 | \$374.32 |
| 15" x 42" | \$87.96 | \$97.90 | \$133.58 | \$145.00 | \$154.67 | \$335.58 | \$379.32 |
| 15" x 47.5" | \$87.96 | \$97.90 | \$133.58 | \$145.00 | \$154.67 | \$335.58 | \$379.32 |
| 15" x 54" | \$160.92 | \$180.80 | \$252.17 | \$275.00 | \$294.33 | \$656.17 | \$743.63 |
| 15" x 60" | \$160.92 | \$180.80 | \$252.17 | \$275.00 | \$294.33 | \$656.17 | \$743.63 |
| 15" x 66"+ | \$165.92 | \$185.80 | \$257.17 | \$280.00 | \$299.33 | \$661.17 | \$748.63 |

18" high

| Dimension | Moxie White Matte | Moxie Graphic Panel | HPL Tier 1 Laminate | Clear Acrylic | Frosted Acrylic | Magnetic White | Magnetic Black |
|-------------|-------------------|---------------------|---------------------|---------------|-----------------|----------------|----------------|
| 18" x 23.5" | \$53.78 | \$59.74 | \$81.15 | \$88.00 | \$93.80 | \$202.35 | \$228.59 |
| 18" x 30" | \$82.96 | \$92.90 | \$128.58 | \$140.00 | \$149.67 | \$330.58 | \$374.32 |
| 18" x 36" | \$97.55 | \$109.48 | \$152.30 | \$166.00 | \$177.60 | \$394.70 | \$447.18 |
| 18" x 42" | \$102.55 | \$114.48 | \$157.30 | \$171.00 | \$182.60 | \$399.70 | \$452.18 |
| 18" x 47.5" | \$102.55 | \$114.48 | \$157.30 | \$171.00 | \$182.60 | \$399.70 | \$452.18 |
| 18" x 54" | \$233.88 | \$263.70 | \$370.75 | \$405.00 | \$434.00 | \$976.75 | \$1,107.95 |
| 18" x 60" | \$233.88 | \$263.70 | \$370.75 | \$405.00 | \$434.00 | \$976.75 | \$1,107.95 |
| 18" x 66"+ | \$238.88 | \$268.70 | \$375.75 | \$410.00 | \$439.00 | \$981.75 | \$1,112.95 |

23.5" high

| Dimension | Moxie White Matte | Moxie Graphic Panel | HPL Tier 1 Laminate | Clear Acrylic | Frosted Acrylic | Magnetic White | Magnetic Black |
|---------------|-------------------|---------------------|---------------------|---------------|-----------------|----------------|----------------|
| 23.5" x 23.5" | \$64.72 | \$72.18 | \$98.94 | \$107.50 | \$114.75 | \$250.44 | \$283.24 |
| 23.5" x 30" | \$82.96 | \$92.90 | \$128.58 | \$140.00 | \$149.67 | \$330.58 | \$374.32 |
| 23.5" x 36" | \$119.44 | \$134.35 | \$187.88 | \$205.00 | \$219.50 | \$490.88 | \$556.48 |
| 23.5" x 42" | \$124.44 | \$139.35 | \$192.88 | \$210.00 | \$224.50 | \$495.88 | \$561.48 |
| 23.5" x 47.5" | \$124.44 | \$139.35 | \$192.88 | \$210.00 | \$224.50 | \$495.88 | \$561.48 |
| 23.5" x 54" | \$233.88 | \$263.70 | \$370.75 | \$405.00 | \$434.00 | \$976.75 | \$1,107.95 |
| 23.5" x 60" | \$233.88 | \$263.70 | \$370.75 | \$405.00 | \$434.00 | \$976.75 | \$1,107.95 |
| 23.5" x 66"+ | \$238.88 | \$268.70 | \$375.75 | \$410.00 | \$439.00 | \$981.75 | \$1,112.95 |

Adjoin™

ADAPTIVE PANEL SYSTEM

Divide and unite.
Divide and unite.
Divide and unite.
Divide and unite.

Freestanding Partitions

Workstation protection, space division, traffic dividers – Adjoin freestanding partitions perform the functions you need with a refreshingly simple structure and endless style options.

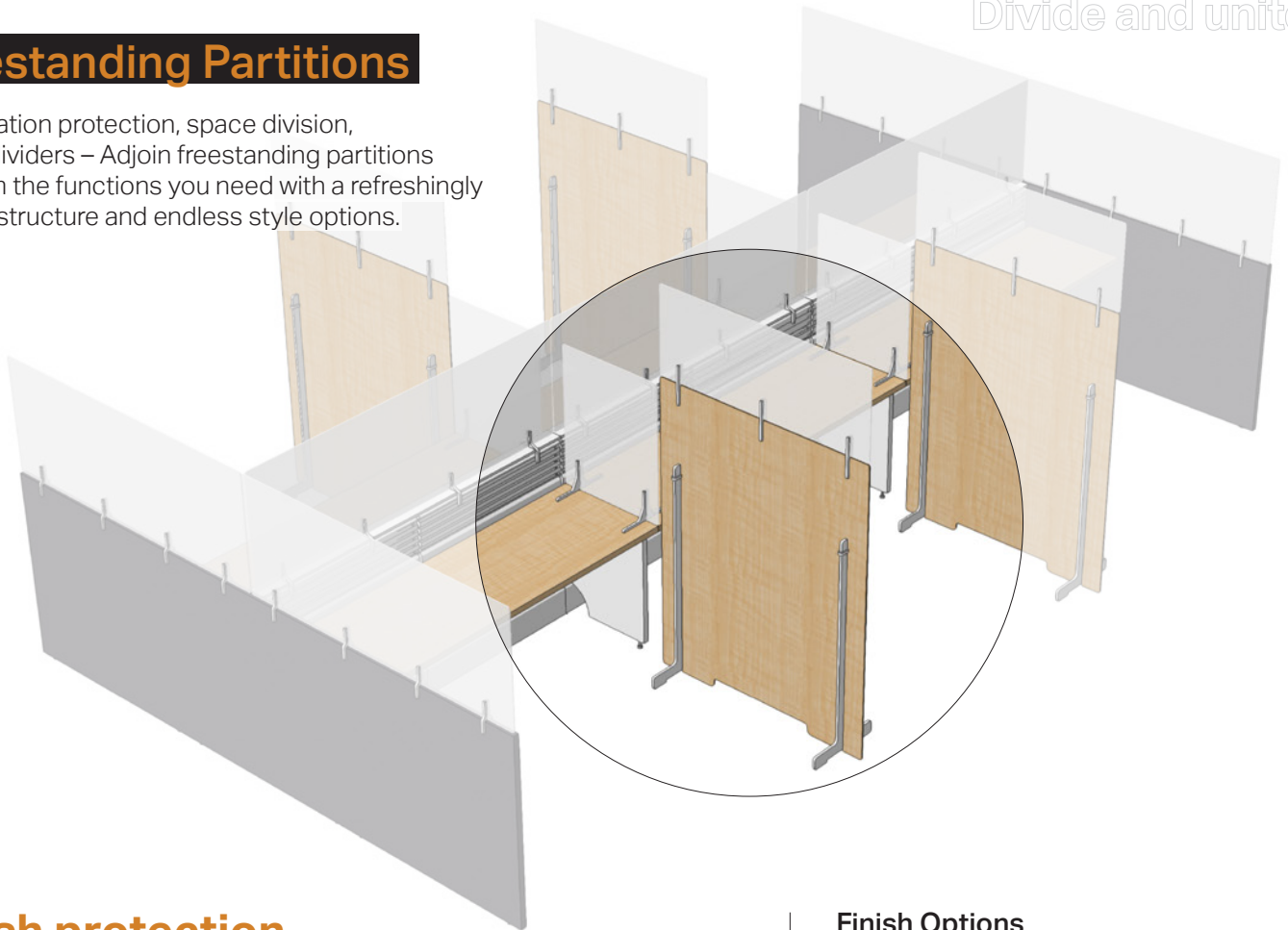

Stylish protection.

Virtually effortless assembly.

Simple tool-free self-installation with aesthetic options to complement your space.

Standard Sizes

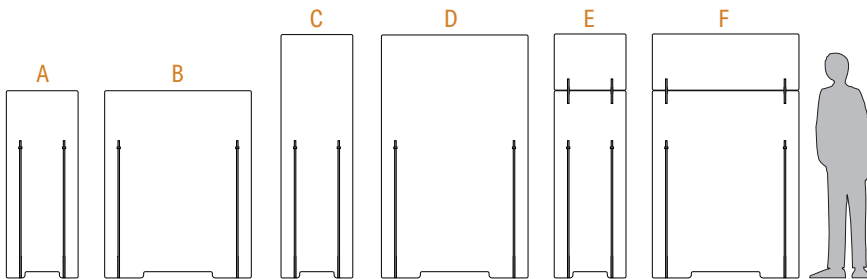

Sitting height

A | 23.5" W x 60.0" h
B | 47.0" W x 60.0" h

Standing height

C | 23.5" W x 78.0" h
D | 47.0" W x 78.0" h

60" partition with stacker

E | 23.5" W x 60.0" h w/ 18.0" h stacker
F | 47.0" W x 60.0" h w/ 18.0" h stacker

Finish Options

Any high pressure laminate

Match your existing furniture or add a new contrasting finish to energize your space.

Magnetic high pressure laminate

Add practical functionality with white or black magnetic laminate.

Aluminum Composite Material (ACM)

Choose ACM for its inherent clean white finish or specify direct-print graphics for your partitions to add a new dimension of visual interest. Your imagery or ours – brand graphics, patterns, photos – the potential is endless. We call our brand of printed ACM "Moxie."

Clear or frosted acrylic stackers

Preserve your site lines and light quality while encouraging community with transparent or translucent stackers to top off 60" h partitions.

2-minute self-install

takeform

Step 1: Specify partition size

Sitting-height

- A | 23.5" W x 60.0"h
- B | 47.0" W x 60.0"h

Standing-height

- C | 23.5" W x 78.0"h
- D | 47.0" W x 78.0"h

60" partition with 18" stacker

- E | 23.5" W x 60.0"h w/ 18.0"h stacker
- F | 47.0" W x 60.0"h w/ 18.0"h stacker

Step 2: Specify leg color and style



1. Black

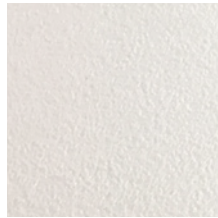

2. White



3. Gray

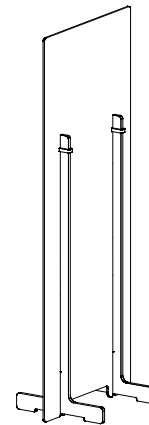

Style 1: Low profile

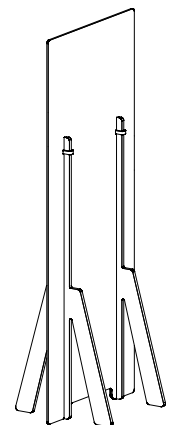

Style 2: Strut

Step 3: Specify material

Provide specification for partition and stacker (if applicable).

1. **ACM** (Moxie) with optional custom direct-print graphics (Moxie)
2. **High pressure laminate**
3. **Magnetic high pressure laminate**
4. **Clear or frosted Acrylic** (for stackers only)

Freestanding Partition Specifications

Configurations

- Four standard sizes
- 18" stackers available for 60"h partitions
- Two leg style options

Cleanable materials

- All material options provide smooth cleanable surfaces for easy disinfecting with effective cleaning agents, *including bleach*
- Specify material to complement furniture, space, or brand:
 - Aluminum Composite Material (ACM) with optional printing (Moxie)
 - High pressure laminate
 - Magnetic (black or white)
 - Clear and frosted acrylic for stackers only
- Specify feet/legs in black, white, or gray
- Direct print graphics for added creative potential (ACM)

Custom shapes

- Standard half-inch corner radius spec provides maximum protection
- Specify the four-inch corner radius to complement the aesthetic of your furniture or space
- Optional top-edge shaping: angle, curve, wave, etc. to reflect the architectural line of your space or other design cue

Simple self-assembly/installation

- Flat pack shippable
- Assembles in field with minimal/no tools
- No installation crew; No installation cost



High pressure laminates and printed patterns provide endless design possibilities

Step 4: Graphics for ACM panels (optional)

Select from our standard patterns (see pages 5-8) or collaborate with Takeform design team to create custom graphics for your Adjoin panels.

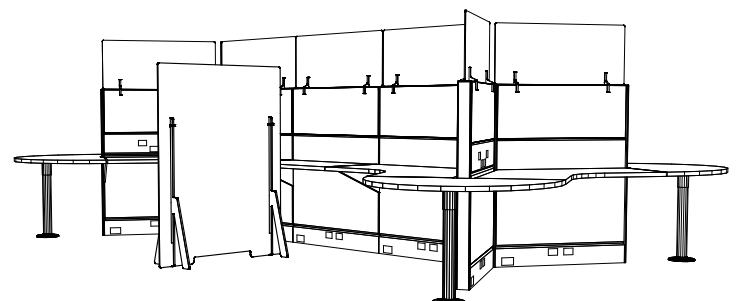

Adjoin™

ADAPTIVE PANEL SYSTEM

Pricing for Adjoin Freestanding partitions

60" high

| Dimension | Moxie White Matte | Moxie Graphic Panel | HPL Tier 1 Laminate | Magnetic White | Magnetic Black |
|----------------------------------|-------------------|---------------------|---------------------|----------------|----------------|
| 60"h x 23.5"w | \$438.88 | \$468.70 | \$575.75 | \$1,181.75 | \$1,312.95 |
| Add an 18" Acrylic Panel Stacker | \$88.00 | \$88.00 | \$88.00 | \$88.00 | \$88.00 |
| 60"h x 47"w | \$657.75 | \$717.40 | \$931.50 | \$2,143.50 | \$2,405.90 |
| Add an 18" Acrylic Panel Stacker | \$171.00 | \$171.00 | \$171.00 | \$171.00 | \$171.00 |

78" high

| Dimension | Moxie White Matte | Moxie Graphic Panel | HPL Tier 1 Laminate | Magnetic White | Magnetic Black |
|---------------|-------------------|---------------------|---------------------|----------------|----------------|
| 78"h x 23.5"w | \$438.88 | \$468.70 | \$575.75 | \$1,181.75 | \$1,312.95 |
| 78"h x 47"w | \$657.75 | \$717.40 | \$931.50 | \$2,143.50 | \$2,405.90 |

takeform

Adjoin Standard Pattern Options

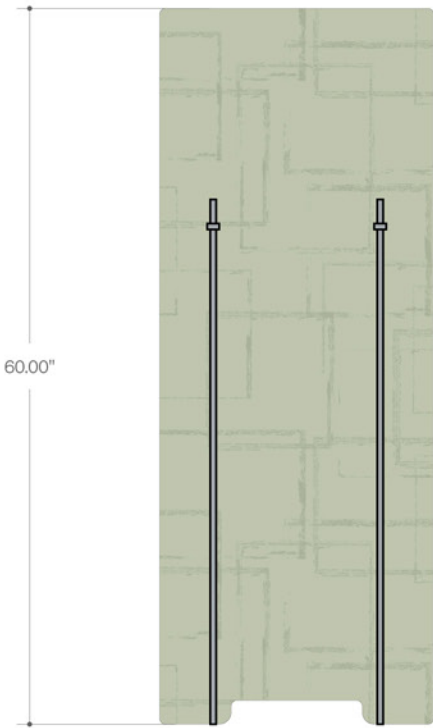

PATJ.1-A



PATJ. 1-B



PATJ.1-C



PATJ.2-A

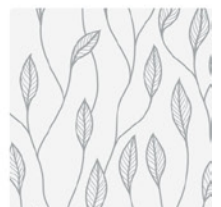

PATJ.2-B



PATJ.2-C

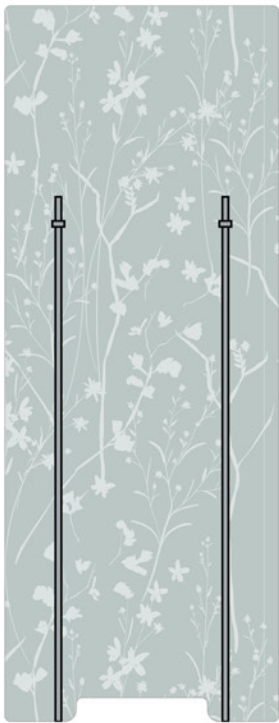

PATJ.3-A



PATJ.3-B



PATJ.3-C

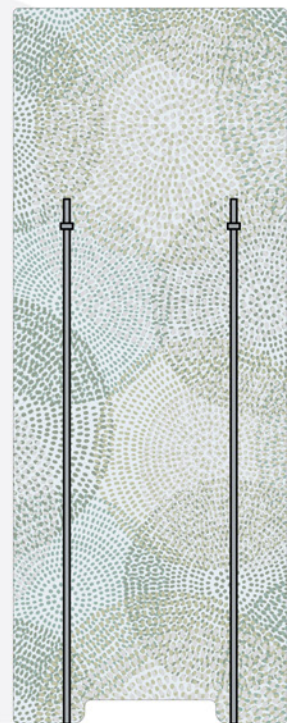

PATJ.4-A



PATJ.4-B



PATJ.4-C

Adjoin Standard Pattern Options

