



K61

**Materials/Tools Required:**

- Level
- Pencil
- Tape Measure
- Sign Setter\*
- Caulk Gun
- GE RTV 108 or RTV 6700 Clear Silicone Adhesive \*
- \*Available from Takeform

**Recommended Cleaning Materials:**

- Lint Free Cloth or Wipes
- Novus® 1 Plastic Cleaner and Polish

**Important:** Wall surface must be clean and dry prior to adhering signs. Allow paint to dry at least 72 hours.

**Location Requirements:**

- 5" from trim on latch side of door - (ADA compliant and required for sign functionality)
- 60" from floor to top of sign - (ADA compliant)

For more information visit:  
[www.ada.gov/2010ADAstandards\\_index.htm](http://www.ada.gov/2010ADAstandards_index.htm)

**K61 - Attend Patient Room Signs - Slider Tabs Style: Tape Mount**

**Step 1: Using a Sign Setter**

**Warning: Do not remove tape holding slider tabs in until sign is installed on wall. If tape is removed slider tabs could fall out of sign during installation.**

Use a Sign Setter to determine the mounting height of 60" from floor to top of sign and the mounting distance from the door trim of 5" from trim on latch side of door to the edge of the sign face.

Refer to steps 3-5 to ensure adequate adhesion to mounting surface.

If not using a Sign Setter, proceed to Step 2.

**5" of wall space must be available for sides with tabs. This space is needed to allow removal of the slider tabs.**

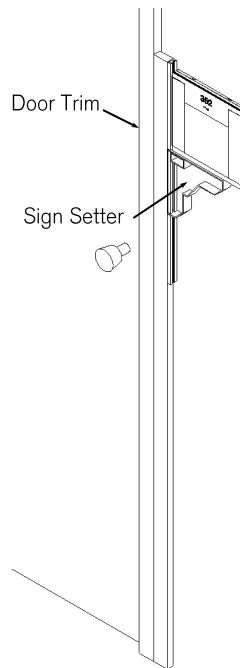

**Step 2:**

Mark required distance of 5" from the door trim on the latch side of door to the edge of the sign face.

Mark the required height of 60" on the wall, which is the distance from the floor to the top of the sign.

**5" of wall space must be available for sides with tabs. This space is needed to allow removal of the slider tabs.**

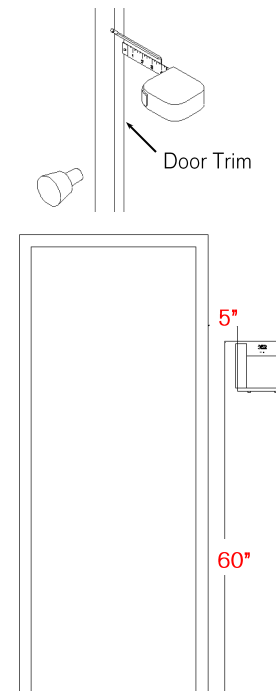

**Step 3:**

Apply 5-6 beads of silicone to back of signs. A bead is defined as roughly 0.75" in diameter (about the size of a dime) and thicker than the thickness of the tape. Some smaller signs may only have space for 3-4 beads, which is sufficient in these cases.

Be sure silicone is applied away from the edges so silicone is not visible when pressed against wall.

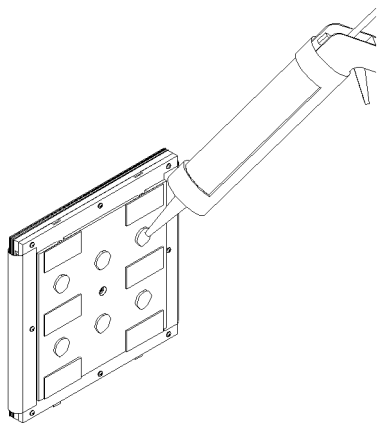

**Step 4:**

Peel liner off of tape pieces. Place sign on wall aligning with measurement marks. Check that sign is level. Press sign firmly and evenly to wall so that all tape pieces receive 15 PSI of pressure.

**Note:** Silicone adhesive is the primary bonding agent. The tape pieces provide temporary hold until silicone adhesive cures.

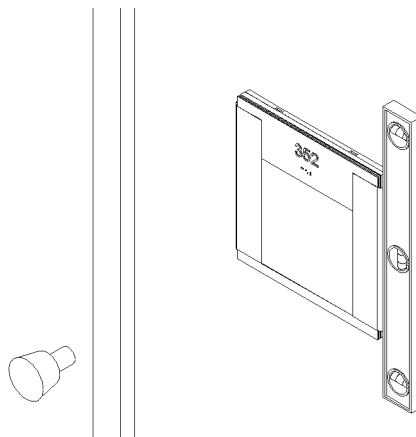

**Step 5:**

Once sign is firmly pressed onto the wall, remove the tape that is holding the slider tabs in place.

Remove finger prints from sign face and edges using recommended cleaning materials. DO NOT use ammonia or alcohol based cleaners.

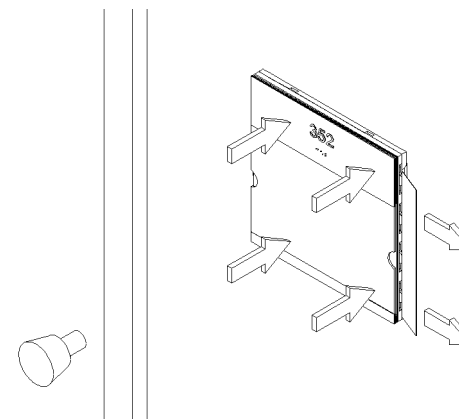

## Attend Patient Room Signs - Slider Tabs Style: Use and Care Guide

### Design Intent and Features:

The Attend Patient Room Signs with locking slider tabs creates a secure and reliable way to convey critical information in regards to patient care. The tabs will lock in the visible or hidden positions and are easily changeable by releasing the locking mechanism and adjusting accordingly. Tabs can also be removed and replaced with different tabs that have different messages and colors to customize the sign even further.

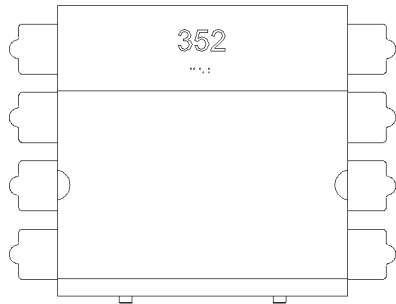

### Locking and Unlocking:

The slider tabs are held in place by the locking bar, these bars can be accessed at the bottom of the sign. To lock and unlock the tabs, push up on the locking bar and slide the tab to the desired view.

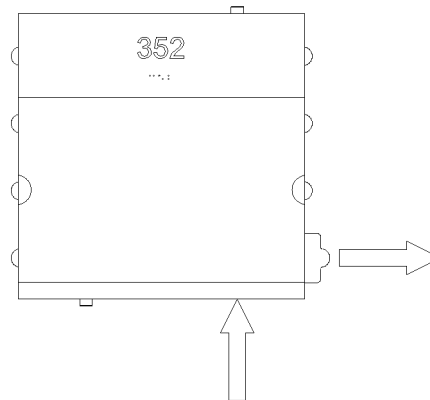

### How to tell if the sign is not locked:

If the sign is not properly locked the locking bar will stick out of the top of the sign. The sign will not lock unless all the tabs are either in a fully hidden or fully visible position.

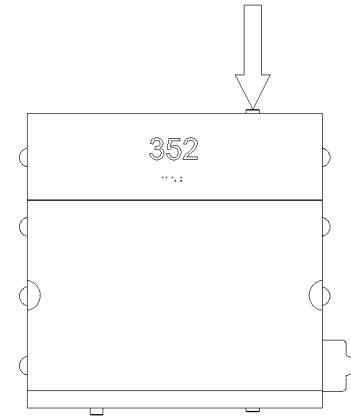

### Tab Removal:

The tabs can also be removed for replacement or cleaning. To remove the tabs, the bar must be pushed up to past flush with the bottom of the sign. This may require the use of a common office supply such as a pen, pencil, paperclip, or thumbtack.

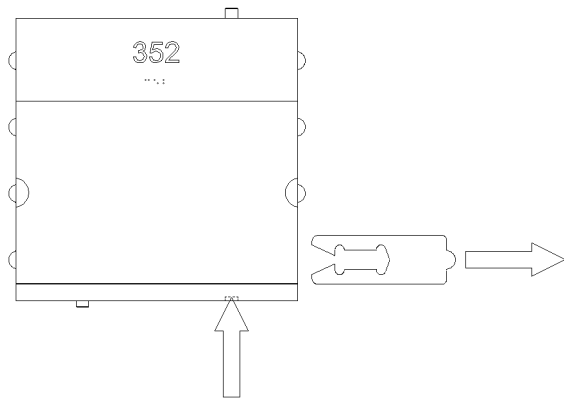

### Tab Insertion:

To insert tabs back into the sign, just slide the tabs in. The locking bar does not need to be pressed to insert the tabs back into the sign.

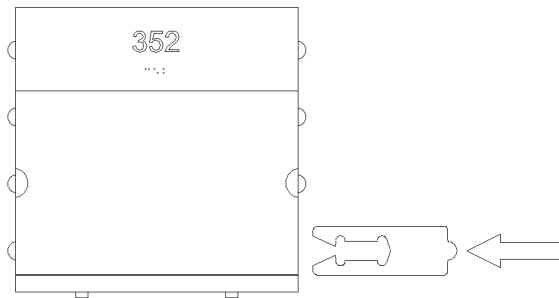

### How to clean:

Use a lint free, non-abrasive cloth to wipe down the slider tabs and face of the sign with one of the cleaning agents listed below. Do not use any abrasive material - as this may damage the surface of the sign.

- Virex® Tb
- Clorox® Clean-Up with Bleach
- Clorox® disinfectant wipes
- Purell® sanitizer wipes
- Isopropyl Alcohol
- Fantastik®
- Formula 409®
- Windex®
- Glass Plus®
- Dish washer soap and water solution mixture