



- Purity maximum upto 99.99%
- Modular aluminum construction for corrosion free
- Universal voltage 100-240V AC - 50/60Hz - 1ph
- Compact in size
- Faster payback period



Nitrogen Gas Generator

PSA BASED NITROGEN GENERATION SYSTEM

The Trident nitrogen generator systems are perfect for anyone who wants their own flexible and reliable supply of nitrogen without compromising on quality. Trident Nitrogen Generators allow you to produce the gas exactly where you need it, when you need it.

Benefits

- Produce as per Demand
- Avoid Cylinder Availability Issues
- Avoid Logistics and Management Problem
- Faster Payback period within 1Year and lesser
- Eliminate safety risk associated with handling high pressure cylinders
- Can be used as Mobile application also
- Avoid unused gas in the cylinder.

Principle of Operation

Drying Cycle : Purified (Moisture and oil free) air from the compressed air system, Passing through one of the aluminium tower filled with Carbon Molecular Sieves. The CMS selectively adsorbs oxygen, allowing nitrogen to pass through at the desired purity level.

Regeneration Cycle : During regeneration cycle, the sudden depressurisation brings out oxygen molecules strapped in the CMS pores to the surface of the beads. Small portion of Nitrogen from the drying tower is passes over the CMS through the regeneration orifice. This results in complete regeneration of Carbon Molecular Sieves.

The automatic cycling of the adsorption and desorption between the two beds enables the continuous production of Nitrogen.

Detailed design of process parameters followed by extensive validation has resulted in consistant performance in NitroGen Series.

All Aluminium construction hence life long corrosion free. All the joints are modularly designed non welded gasketted technology.

Highly reliable Microprocessor based controller with LED display of generator operations. This controller has designed to suit universal voltage.

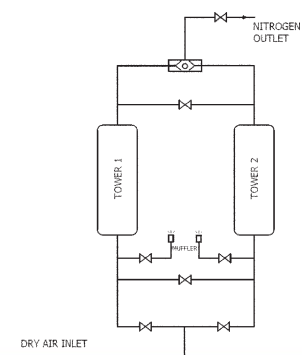

Recommended installation is for On-site Gas Generation as per below.



As per ISO-8573.1 Class 1-4-1



Trident generators are designed in such way, it will work at site 24 x 7 without any trouble. All the components used in generators are highly reliable and tested, validated for long life period. Optional safety precautions can be addressed (Stand by gas supply mode automatically in case of any failure mode like, Purity, Power failure etc.) to give uninterrupted gas supply.

However trained service personal will attend the service calls for breakdown as well as preventive maintenance. Necessary documents will be provided and training will be given to the users to handle minor breakdowns.

- 45 service outlet in India
- Centralized service logging system
- Onsite Training for the users
- Genuine spares available at nearest point
- Competitive and effective Annual Maintenance Contracts available at the end of warranty period

Rated Capacity in Nm³/Hr at indicated Purity Level

Nitrogen Purity %		99.99		99.9		99.5		99		98		97		95		Inlet air requirement in
Oxygen Level %		0.01		0.1		0.5		1.0		2.0		3.0		5.0		
Model	Item Code	Nm ³ /Hr	LPM	Nm ³ /Hr	LPM	Nm ³ /Hr	LPM	Nm ³ /Hr	LPM	Nm ³ /Hr	LPM	Nm ³ /Hr	LPM	Nm ³ /Hr	LPM	Nm ³ /Hr
NitroGen 10	PNG01	0.4	6.7	1	16.7	1.4	23.3	1.7	28.3	2	33.3	2.3	38.3	2.9	48.3	4.3
NitroGen 20	PNG02	1	16.7	2.2	36.7	3.2	53.3	3.8	63.3	4.5	75.0	5.1	85.0	6.4	106.7	9.9
NitroGen 30	PNG03	2	33.3	4.3	71.7	6.4	106.7	7.7	128.3	9	150.0	10.3	171.7	12.9	215.0	19.8
NitroGen 40	PNG04	3	50.0	6.6	110.0	9.7	161.7	11.6	193.3	13.5	225.0	15.5	258.3	19.3	321.7	30.0
NitroGen 50	PNG05	3.8	63.3	8.3	138.3	12.2	203.3	14.7	245.0	17.1	285.0	19.5	325.0	24.5	408.3	37.8

For higher capacity please contact factory. Specifications are subjected to change based on continuous improvement.

Compressed air specification

Air quality requirement is as per ISO 8573.1 -1.4.1

Inlet temperature + 5 Deg C to 40 deg C

Operating Pressure 7 Kg/cm² to 12 Kg/cm²

Electrical requirement 100 to 230 V, 50/60 HZ, Single phase

Ordering Procedure :

Eg: If you required flow rate of 3 Nm³/ Hr at 99.99% Purity.

Your ordering code would be : Nitrogen 40.

Treatment Products from Trident to achieve ISO 8573.1 Class 1-4-1



Refrigeration Dryer

- Highly Efficient refrigeration air dryer for pretreatment of compressed air
- Dew point as per ISO 8573 class 4
- Eco friendly refrigerant (R134a, R407c)

High Efficient Coalescing filters to remove

- Moisture
- Dust Particle up to 0.01 micron
- Oil Aerosols up to 0.003mg/cu.m

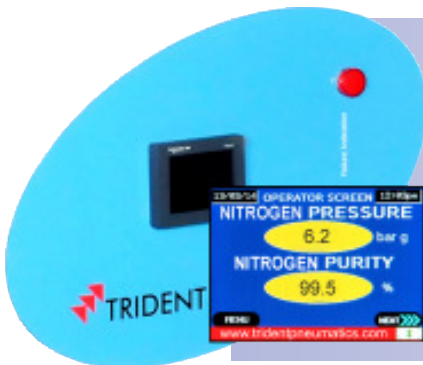

PLC Based controller with Digital Display - Optional

- Gas Purity
- Pressure
- Failure warning visual & Audible
- Operation hours
- Provide indication of plant maintenance schedule

Air and Nitrogen Tank

- Compressed air and oxygen tanks are designed as per IS 2825
- Anti-corrosive paint for better life
- Optional : SS Tank
- Pressure Safety valve, Pressure gauges and draining system for automatic and manual



Trident Pneumatics Pvt Ltd

5/232, K.N.G. Pudur Road, Coimbatore - 641 108, India. Ph : +91-422-2400492, 2401373 Fax : +91-422-2401376

e-mail : sales@tridentpneumatics.com / www.service@tridentpneumatics.com



Sales & Service Outlets

Ahmedabad
98673 67726

Bangalore
98450 93322

Chennai
97894 80564

Delhi
93113 10726

Hyderabad & Kolkatta
98854 45321

Mumbai & Pune
98673 67726

Website : www.tridentpneumatics.com