

IF IN DOUBT PLEASE ASK

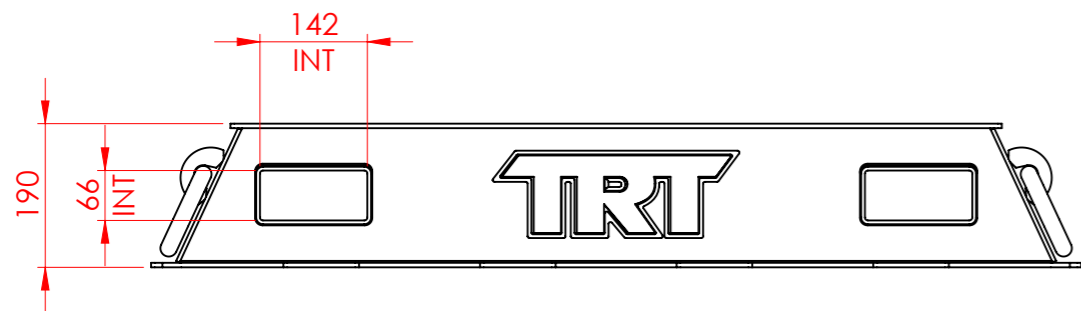
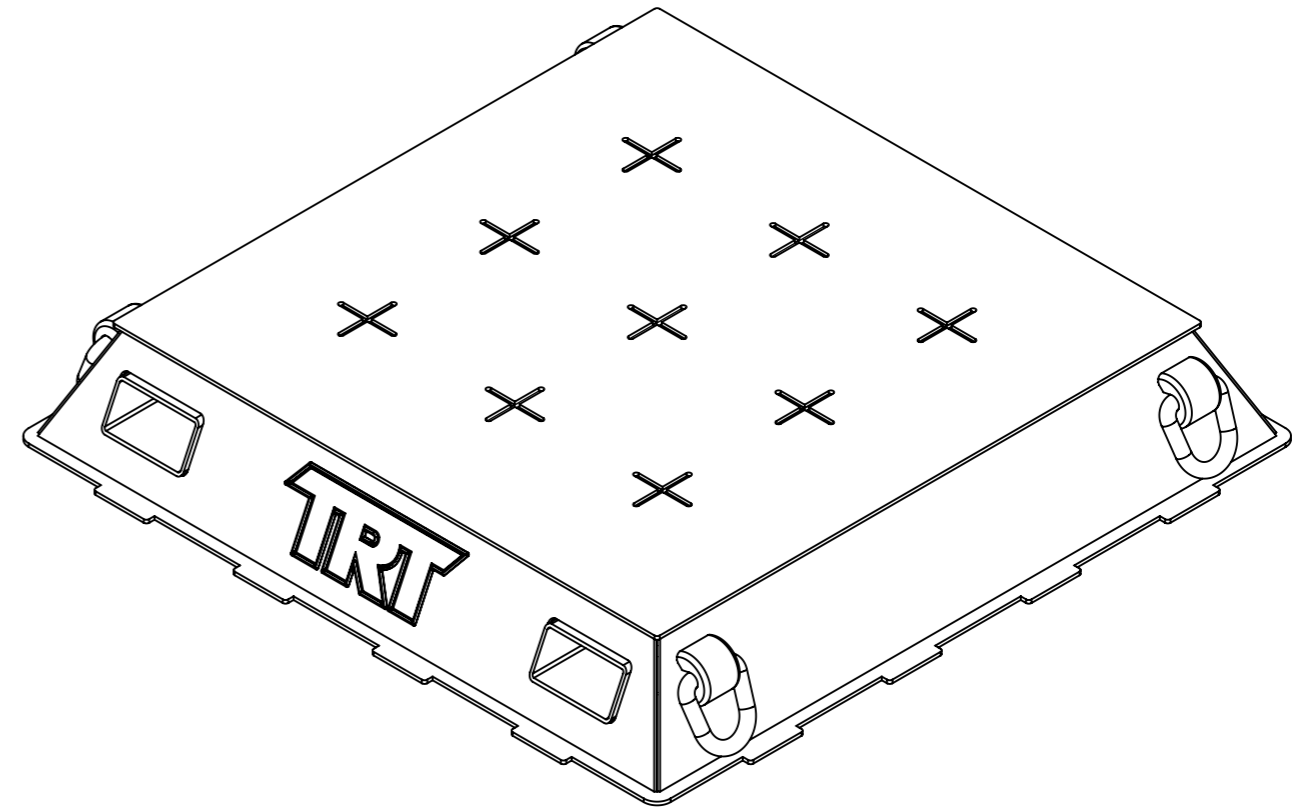
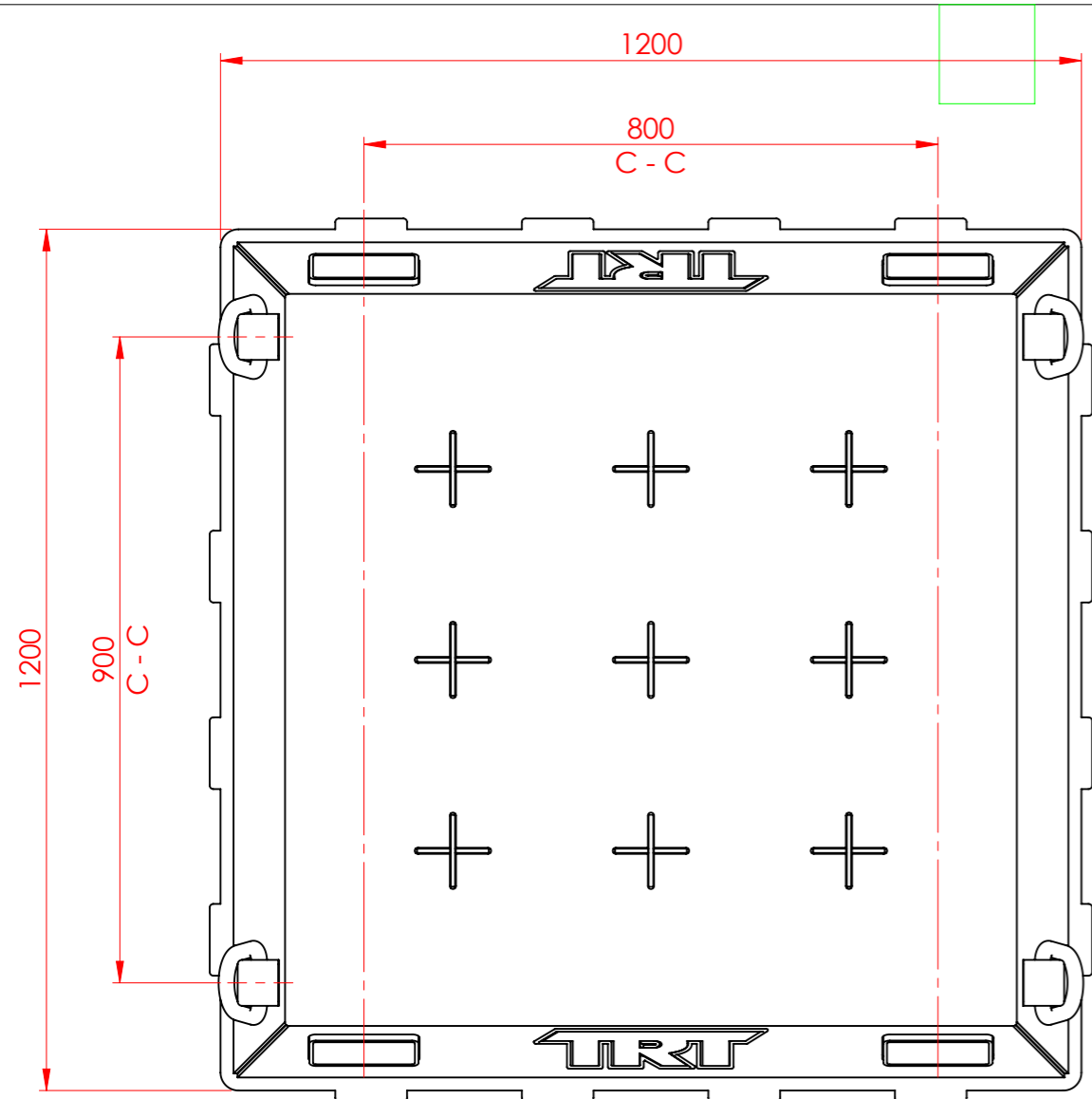

TRT Crane Pads evenly distribute outrigger crane loads. Quality engineering ensures all TRT Crane Pads adhere to the CICA industry standards.

### PAD-014-DP

PAD WEIGHT: 257kg

MINIMUM FOOT SIZE: Ø300mm

MAXIMUM SPAN: 1000mm

MAXIMUM LOAD: 150T

### Ground Pressure Rating

WIDTH (mm)		1200
LENGTH (mm)		1200
CONTACT AREA (m <sup>2</sup> )		1.4
GROUND PRESSURE	kg / m <sup>2</sup>	kPa
25 TONNE	17361	170
50 TONNE	34722	341
100 TONNE	69444	681
150 TONNE	104167	1022

**UNLESS OTHERWISE STATED**  
 GENERAL TOLERANCES  
 0.00 = ± 0.05  
 0.0 = ± 0.2  
 0 = ± 0.5  
 ANGLES  
 0 = ± 0.5°  
 THIRD ANGLE PROJECTION  
 SURFACE FINISH (µm)  
 1.6

WELDING: ALL INFORMATION SHALL COMPLY WITH NZ/AS 1554:2000 PT 1 CATEGORY SP UNLESS OTHERWISE STATED AND SHALL BE WELDED TO A QUALIFIED PROCEDURE, BY A WELDER QUALIFIED FOR THE APPROPRIATE POSITION AND SUPERVISED BY A WELDING SUPERVISOR

REV	DATE	COMMENT	NAME
B	23/08/23	UPDATED TRT LOGO	SH
A	14/05/20	FIRST ISSUE	JH



**TIDD ROSS TODD LTD**  
 48 Maui Street, Hamilton,  
 New Zealand  
 Phone: +64 7 849 4839  
 Email: trt@trt.co.nz  
 Website: trt.co.nz  
 ISO9001:2015

NAME	DATE	TITLE:	CRANE PAD 1200 X 1200 ASSY
DRAWN	JH	14/05/20	
CHK'D	-	-	
APPV'D	-	-	
DO NOT SCALE DRAWINGS IN mm's		<b>STATUS - M</b>	SCALE:1:10
SHEET 3 OF 3		DWG NO.	REVISION
PAD-014			<b>B</b>