

ITEM NO.	PART NUMBER	DESCRIPTION	QTY.
1	234-#1A	TRAILER #1 A	1
2	234-#1B	TRAILER #1 B	1
3	234 TRUCK	6 X 4 TRUCK	1

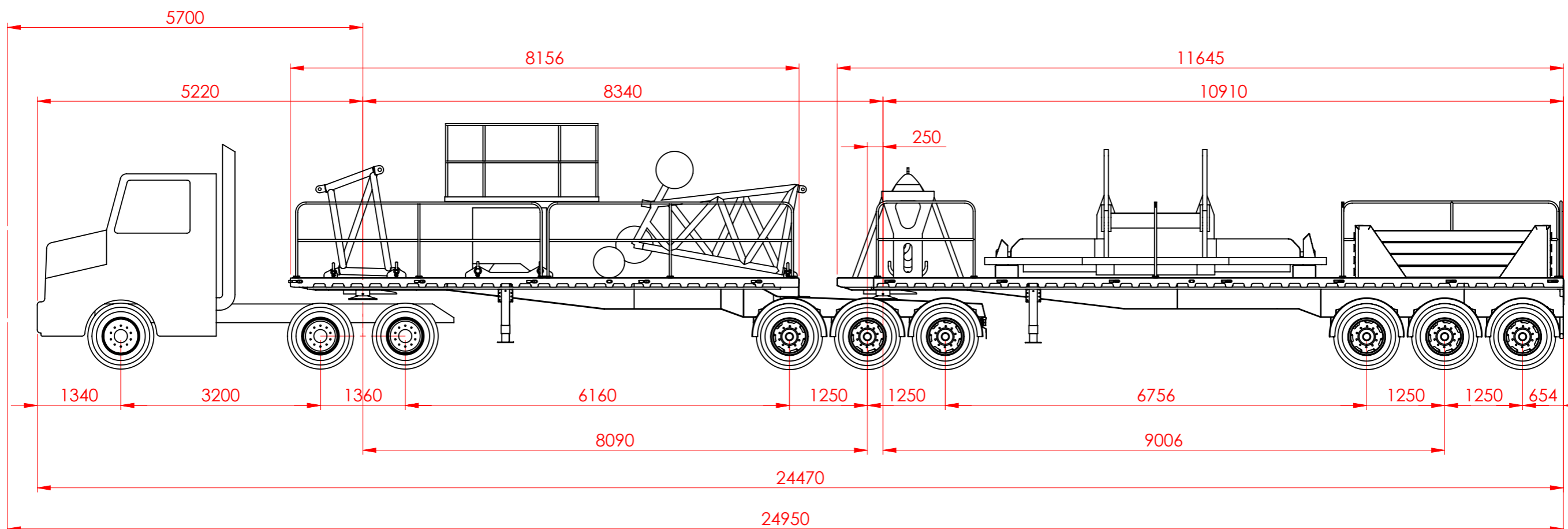
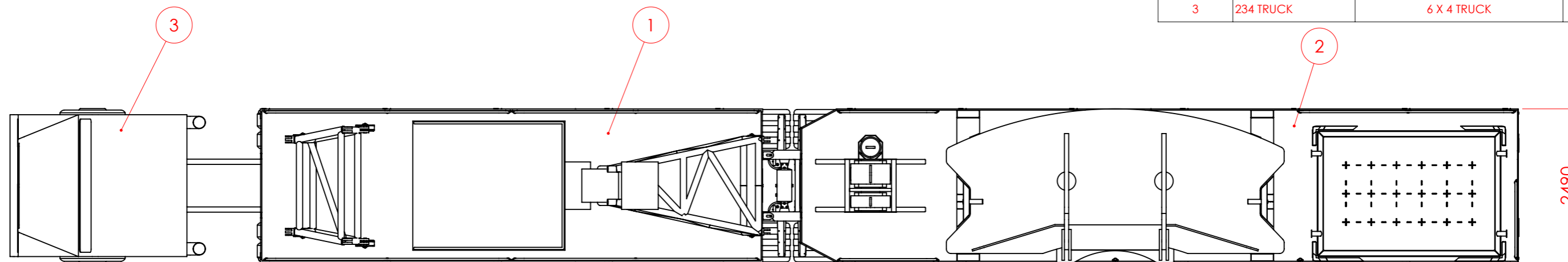

	STEER	DRIVE	TRI	TRI	TOTAL
GVM	5660	9366	17817	16541	49384
LEGAL	6000	17000	21000	21000	65000
% INCREASE	94%	55%	85%	79%	76%

**TOLERANCE:** ± 0.5mm UNLESS OTHERWISE STATED  
**WELDING:** ALL INFORMATION SHALL COMPLY WITH NZ/AS 1554:2000 PT 1 CATEGORY SP UNLESS OTHERWISE STATED AND SHALL BE WELDED TO A QUALIFIED PROCEDURE, BY A WELDER QUALIFIED FOR THE APPROPRIATE POSITION AND SUPERVISED BY A WELDING SUPERVISOR

THIS DRAWING IS © COPYRIGHT AND IS THE PROPERTY OF TIDD ROSS TODD LTD. IT IS FURNISHED TO YOU FOR CONFIDENTIAL INFORMATION PURPOSES ONLY AND IS NOT TO BE DISCLOSED TO ANYONE ELSE OR USED FOR MANUFACTURING PURPOSES WITHOUT THE EXPRESS WRITTEN PERMISSION OF TIDD ROSS TODD LTD.

REV	DATE	COMMENT



48 Maui Street  
 Hamilton, New Zealand  
 Telephone +64 7 849 4839  
 Fax +64 7 849 3628  
 Email : trt@trt.co.nz  
 ISO 9001

NAME	DATE	TITLE:
DRAWN: BJ	10/7/15	COMBINATION #1
CHK'D: -	-	-
APPV'D: -	-	-
DO NOT SCALE DRAWINGS IN mm's	<b>STATUS - M</b>	SHEET 1 OF 2
	SCALE:1:70	DWG NO. 234-#1
		REVISION A

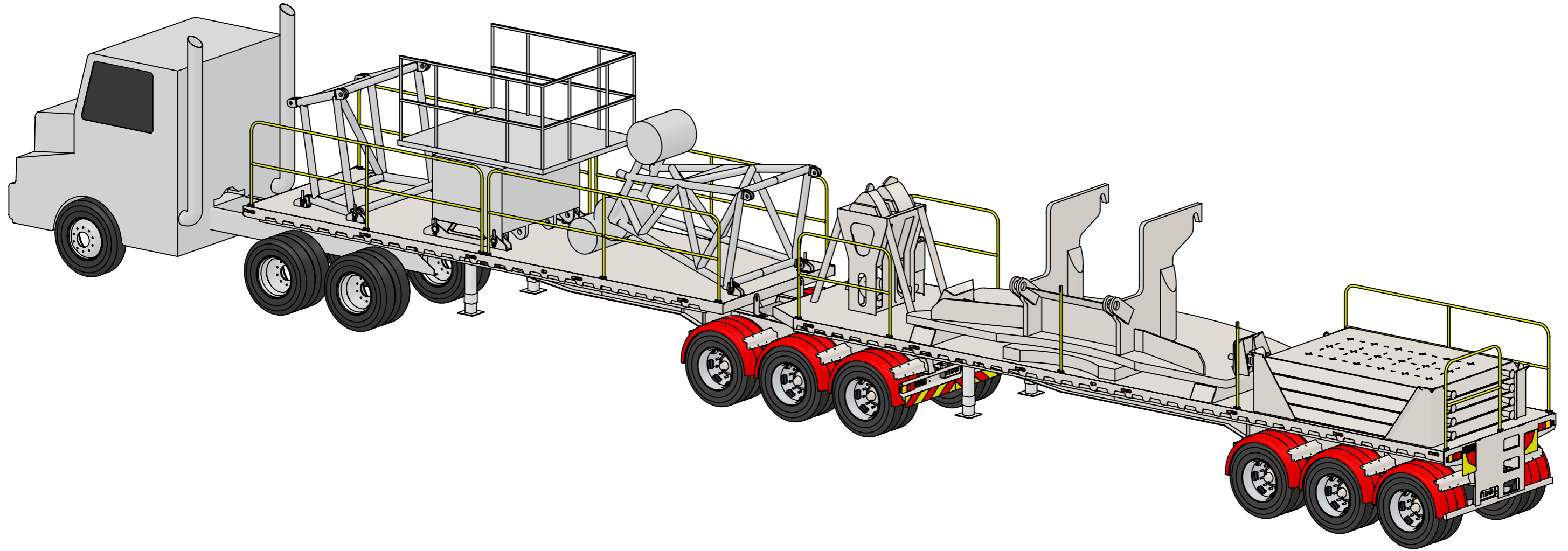

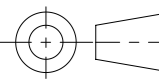
**TOLERANCE** : ± 0.5mm UNLESS OTHERWISE STATED  
**WELDING**: ALL INFORMATION SHALL COMPLY WITH NZ/AS 1554:2000 PT 1 CATEGORY SP UNLESS OTHERWISE STATED AND SHALL BE WELDED TO A QUALIFIED PROCEDURE, BY A WELDER QUALIFIED FOR THE APPROPRIATE POSITION AND SUPERVISED BY A WELDING SUPERVISOR  
 WIRE BUFF ALL STEEL COMPONENTS PRIOR TO WELDING

THIS DRAWING IS © COPYRIGHT AND IS THE PROPERTY OF TIDD ROSS TODD LTD.  
 IT IS FURNISHED TO YOU FOR CONFIDENTIAL INFORMATION PURPOSES ONLY AND IS NOT TO BE DISCLOSED TO ANYONE ELSE OR USED FOR MANUFACTURING PURPOSES WITHOUT THE EXPRESS WRITTEN PERMISSION OF TIDD ROSS TODD LTD.

REV	DATE	COMMENT



**48 Maui Street**  
**Hamilton, New Zealand**  
 Telephone +64 7 849 4839  
 Fax +64 7 849 3628  
 Email : trt@trt.co.nz  
 ISO 9001

NAME	DATE	TITLE:	REVISION
DRAWN	BJ	10/7/15	COMBINATION # 1
CHK'D	-	-	
APPV'D	-	-	
DO NOT SCALE DRAWINGS IN mm's		<b>STATUS - M</b>	
SHEET 2 OF 2		SCALE:1:55	DWG NO. 234-#1
			<b>A</b>