

SPECIFICATIONS SUBJECT TO  
CHANGE WITHOUT NOTICE

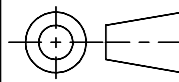
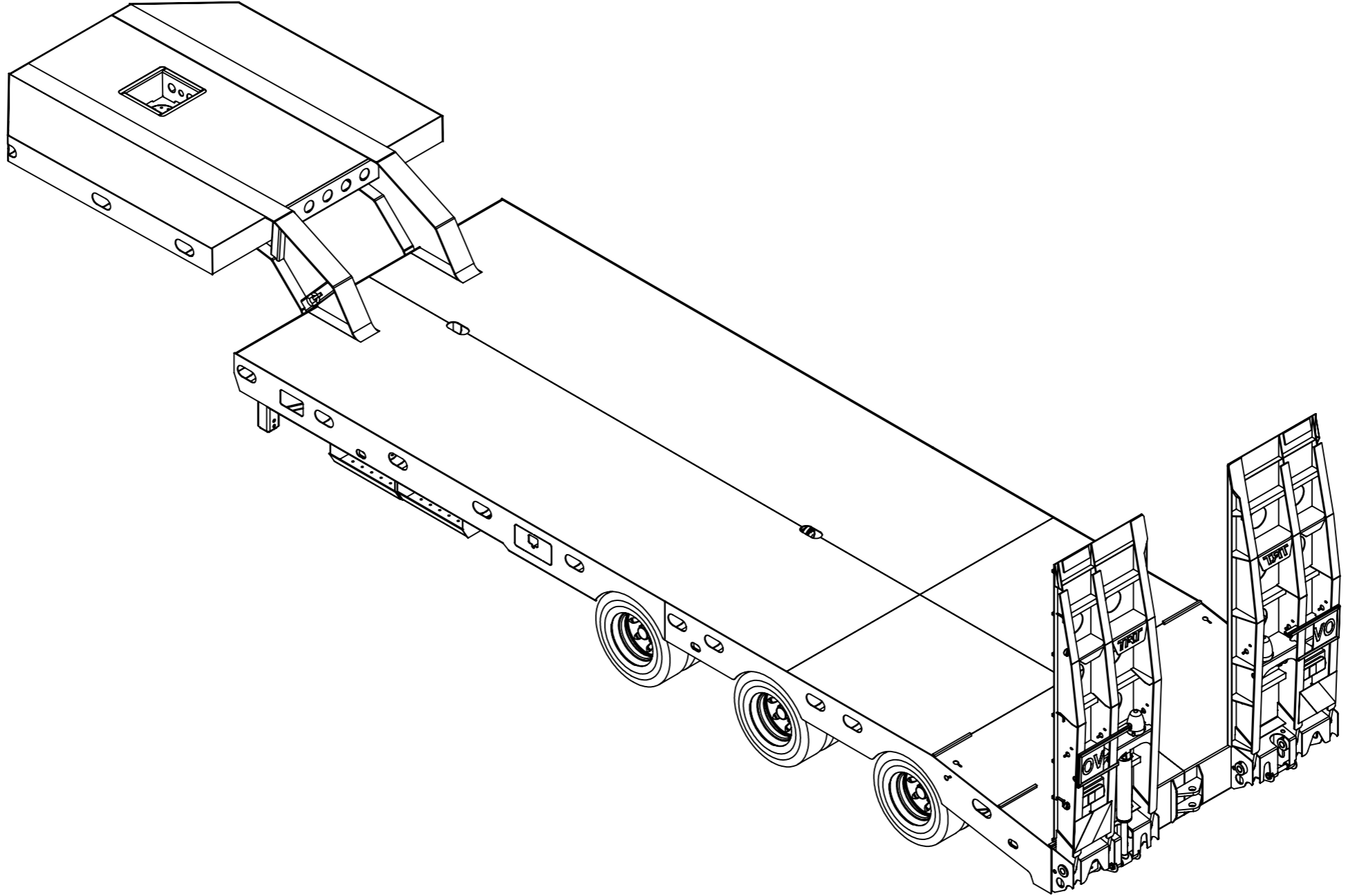

**TOLERANCE** : ± 0.5mm UNLESS OTHERWISE STATED  
**WIRE BUFF** ALL STEEL COMPONENTS PRIOR TO WELDING

**WELDING**: ALL INFORMATION SHALL COMPLY WITH NZ/AS 1554:2000 PT 1 CATEGORY SP UNLESS OTHERWISE STATED AND SHALL BE WELDED TO A QUALIFIED PROCEDURE, BY A WELDER QUALIFIED FOR THE APPROPRIATE POSITION AND SUPERVISED BY A WELDING SUPERVISOR

THIS DRAWING IS © COPYRIGHT AND IS THE PROPERTY OF TIDD ROSS TODD LTD.  
IT IS FURNISHED TO YOU FOR CONFIDENTIAL INFORMATION PURPOSES ONLY AND IS NOT TO BE DISCLOSED TO ANYONE ELSE OR USED FOR MANUFACTURING PURPOSES WITHOUT THE EXPRESS WRITTEN PERMISSION OF TIDD ROSS TODD LTD.

REV	DATE	COMMENT	NAME



**48 Maui Street**  
**Hamilton**  
**New Zealand**  
Phone +64 7 849 4839  
Fax +64 7 849 3628  
Email : trt@trt.co.nz  
ISO 9001

	NAME	DATE
DRAWN	DT	17/04/2018
CHK'D	-	-
APPV'D	-	-
DO NOT SCALE DRAWINGS IN mm's		

TITLE:	REVISION
3 X 4 FIXED WIDTH LOW LOADER	A
SHEET 1 OF 2	DWG NO. 089-A2W
SCALE:1:40	STATUS - M

SPECIFICATIONS SUBJECT TO  
CHANGE WITHOUT NOTICE

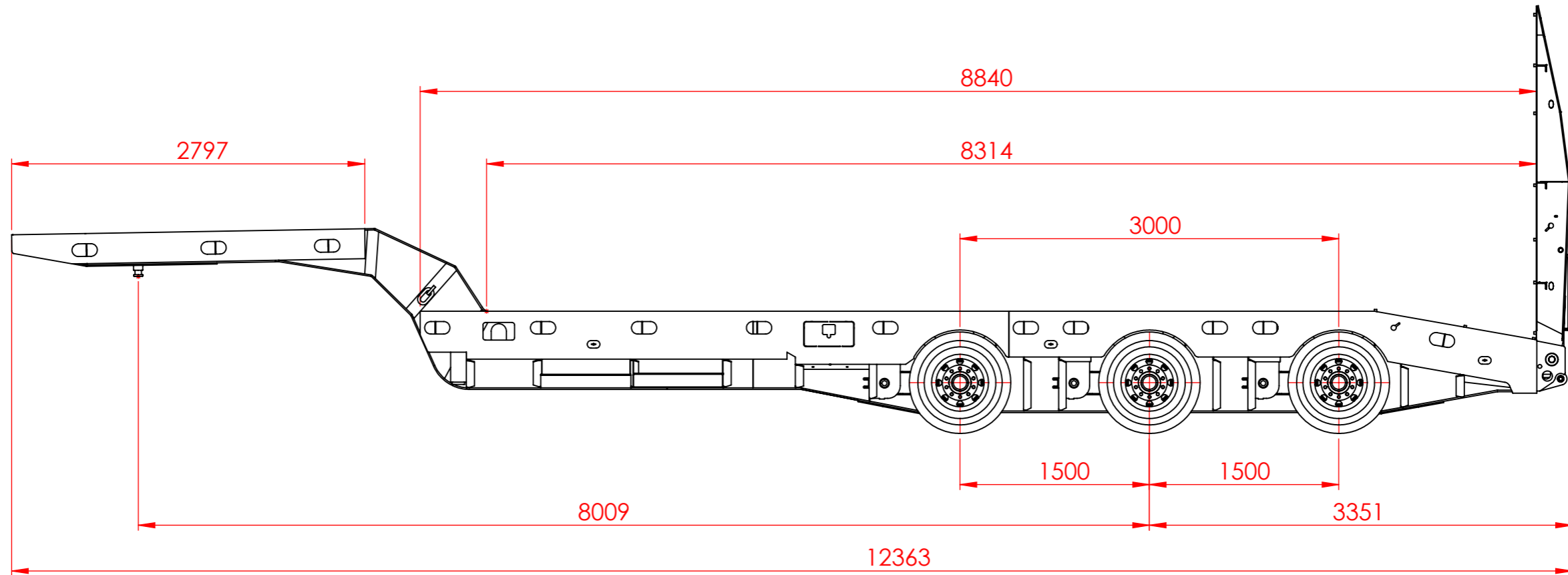

**TOLERANCE : ± 0.5mm UNLESS OTHERWISE STATED**  
**WIRE BUFF ALL STEEL COMPONENTS PRIOR TO WELDING**

**WELDING:** ALL INFORMATION SHALL COMPLY WITH NZ/AS 1554:2000 PT 1 CATEGORY SP UNLESS OTHERWISE STATED AND SHALL BE WELDED TO A QUALIFIED PROCEDURE, BY A WELDER QUALIFIED FOR THE APPROPRIATE POSITION AND SUPERVISED BY A WELDING SUPERVISOR

THIS DRAWING IS © COPYRIGHT AND IS THE PROPERTY OF TIDD ROSS TODD LTD. IT IS FURNISHED TO YOU FOR CONFIDENTIAL INFORMATION PURPOSES ONLY AND IS NOT TO BE DISCLOSED TO ANYONE ELSE OR USED FOR MANUFACTURING PURPOSES WITHOUT THE EXPRESS WRITTEN PERMISSION OF TIDD ROSS TODD LTD.

REV	DATE	COMMENT	NAME



48 Maui Street  
Hamilton  
New Zealand  
Phone +64 7 849 4839  
Fax +64 7 849 3628  
Email : trt@trt.co.nz  
ISO 9001

NAME	DATE
DRAWN DT	17/04/2018
CHK'D -	-
APPV'D -	-

TITLE:	DWG NO.	REVISION
3 X 4 FIXED WIDTH LOW LOADER	089-A2W	A
SHEET 2 OF 2	SCALE:1:40	

DO NOT SCALE DRAWINGS IN mm's  
**STATUS - M**