

# C168D-YL10 - S1250 - M1 - M 400W - B

型號 Model      孔型與導程 Hole type and Lead      行程 Stroke      馬達方向 Motor direction      馬達廠牌及出力 Motor brand and output      煞車 Brake

Y 底部牙孔  
Thread hole

馬達方向 Motor direction

- M1 馬達內置 Motor inside position
- M2 馬達外置 Motor outside position
- M3 馬達外置右側 Motor outside, rightward position
- M4 馬達外置左側 Motor outside, leftward position
- M5 馬達外置上方 Motor outside, upper position
- M6 馬達外置下方 Motor outside, lower position

馬達廠牌及出力 Motor brand and output

- H 上銀 Hiwin
- X 西門子 Siemens
- M 三菱 Mitsubishi
- Y 安川 Yaskawa
- P 松下 Panasonic
- F 富士 Fuji
- T 台達 Delta

## C168D規格表(C168D Specification):

## 線性滑軌20x15.5-2支(Linear Guide20x15.5-2 )

馬達出力 AC Servo motor output(W)	400W				
重覆定位精度 Repeatability(mm)	±0.01				
滾珠螺桿外徑 B.S(Ø)	20	20	20	25	
滾珠螺桿導程 Lead(mm)	5	10	20	25	
最快速度 Maximun speed(mm/sec)	250	500	1000	1250	
最大載重 Maximun payload(kg)	水平使用 (H)	110	80	75	65
	垂直使用 (V)	40	35	15	11
額定推力 Rated thrust(N)	945	480	240	200	
行程 Stroke(mm)	100~1250 50 間隔 (interval)				

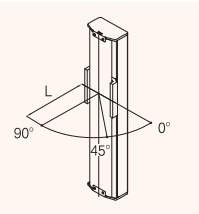
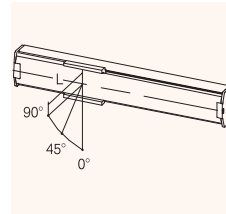
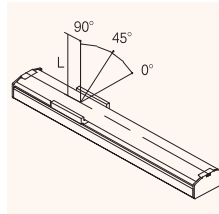

水平安裝應用(單位:mm)  
Horizontal use

導程 Payload	0°	45°	90°
Lead 25 25kg	643	867	1438
45kg	399	512	1103
65kg	240	336	971
30kg	765	922	1749
Lead 20 50kg	454	571	1216
75kg	305	393	1035
Lead 10 50kg	661	808	1371
65kg	499	573	1190
80kg	337	428	1007
Lead 5 70kg	389	530	1398
90kg	220	312	1089
110kg	180	250	950

牆面安裝應用(單位:mm)  
Wall installation use

導程 Payload	0°	45°	90°
Lead 25 25kg	979	460	431
45kg	682	312	300
65kg	566	203	171
30kg	1095	560	550
Lead 20 50kg	730	335	325
75kg	580	215	195
Lead 10 50kg	1212	478	369
65kg	1130	384	335
80kg	973	263	220
Lead 5 70kg	911	400	365
90kg	622	249	197
110kg	464	176	110

垂直安裝應用(單位:mm)  
During vertical use

導程 Payload	0°	45°	90°
Lead 25 3kg	2544	1789	2544
7kg	1383	672	1383
11kg	900	571	900
5kg	2350	1660	2350
Lead 20 10kg	1210	845	1210
15kg	810	570	810
Lead 10 15kg	1610	1138	1610
25kg	950	670	950
35kg	660	468	660
Lead 5 20kg	1577	1099	1577
30kg	782	567	782
40kg	245	130	245

\*滑塊表面中心到搬送物重心的距離(僅供參考)  
Distance center of slider top to center of gravity of object being transported (For reference only)

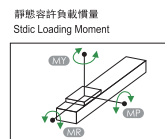

(單位:N.m) [Unit:N.m]  
水平使用時 Static Loading Moment

MY	2052
MP	2052
MR	1810

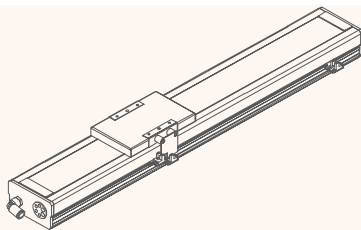

M1

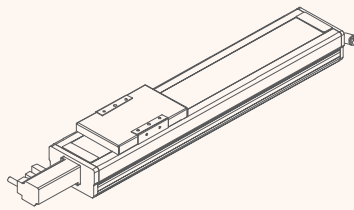

M2

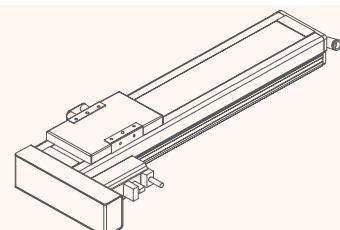

M3

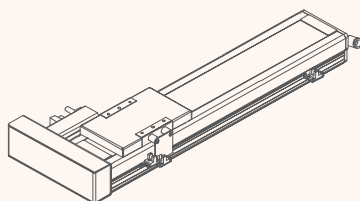

M4

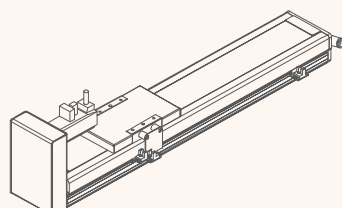

M5

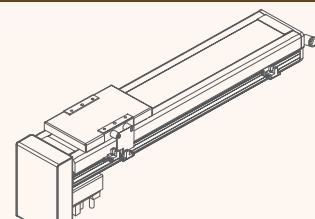

M6

## M1

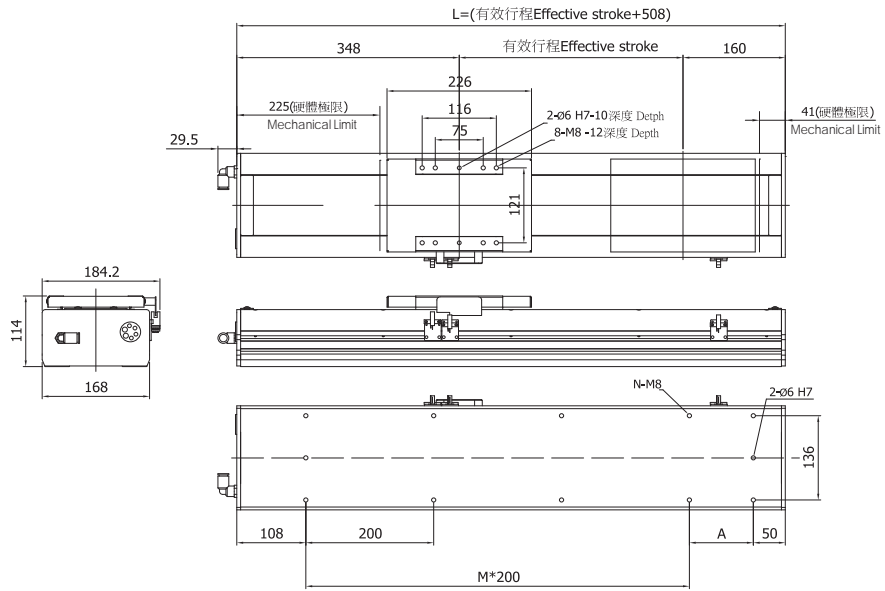

行程 Stroke	100	150	200	250	300	350	400	450	500	550	600	650	700	750	800	850	900	950	1000	1050	1100	1150	1200	1250
L	608	658	708	758	808	858	908	958	1008	1058	1108	1158	1208	1258	1308	1358	1408	1458	1508	1558	1608	1658	1708	1758
A	50	100	150	200	50	100	150	200	50	100	150	200	50	100	150	200	50	100	150	200	50	100	150	200
M	2	2	2	2	3	3	3	3	4	4	4	4	5	5	5	5	6	6	6	6	7	7	7	7
N	8	8	8	8	10	10	10	10	12	12	12	12	14	14	14	14	16	16	16	16	18	18	18	18
重量(kg)	16.6	17.6	18.6	19.6	20.6	21.6	22.6	23.6	24.6	25.6	26.6	27.6	28.6	29.6	30.6	31.6	32.6	33.6	35.6	35.6	36.6	37.6	38.6	39.6

※本公司享有變更規格之權益，恕不另行通知 ※Drawings and specifications are subject to change without prior notice.

## M2

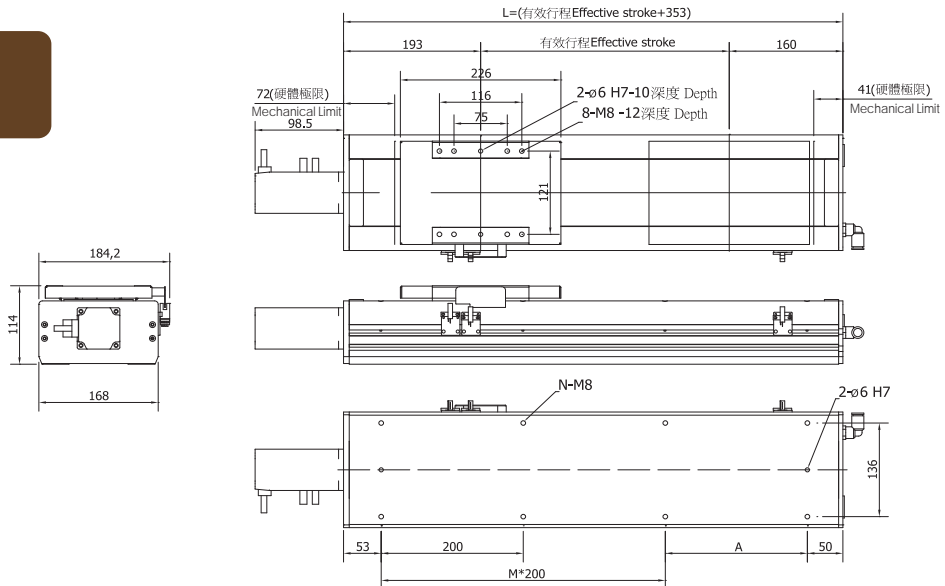

行程 Stroke	100	150	200	250	300	350	400	450	500	550	600	650	700	750	800	850	900	950	1000	1050	1100	1150	1200	1250
L	453	503	553	603	653	708	753	803	853	903	953	1003	1053	1103	1153	1208	1253	1303	1353	1403	1458	1503	1553	1603
A	150	200	50	100	150	200	50	100	150	200	50	100	150	200	50	100	150	200	50	100	150	200	50	100
M	1	1	2	2	2	2	3	3	3	3	4	4	4	4	5	5	5	5	6	6	6	6	7	7
N	6	6	8	8	8	8	10	10	10	10	12	12	12	12	14	14	14	14	16	16	16	16	18	18
重量(kg)	14.0	15.0	16.0	17.0	18.0	19.0	20.0	21.0	22.0	23.0	24.0	25.0	26.0	27.0	28.0	29.0	30.0	31.0	32.0	33.0	34.0	35.0	36.0	37.0

※本公司享有變更規格之權益，恕不另行通知 ※Drawings and specifications are subject to change without prior notice.

# M3

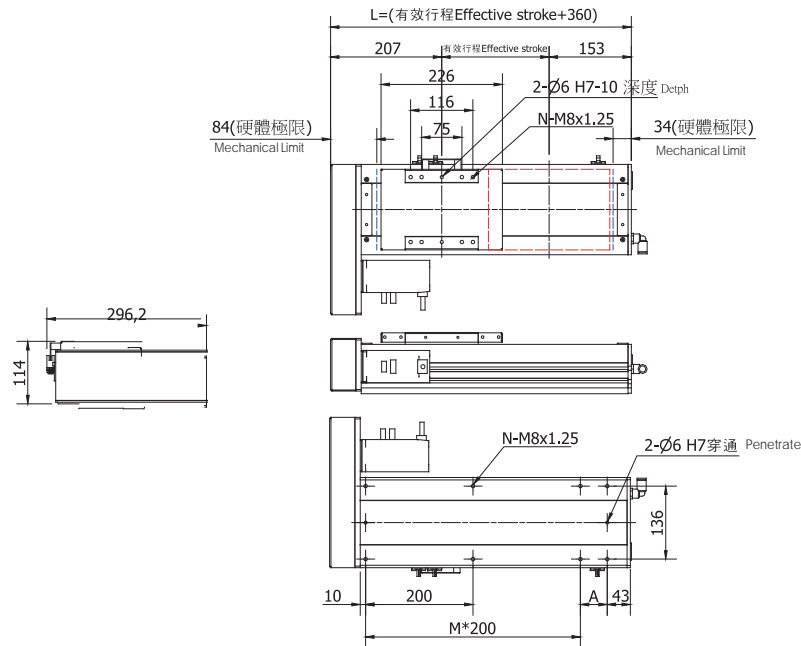

行程 Stroke	100	150	200	250	300	350	400	450	500	550	600	650	700	750	800	850	900	950	1000	1050	1100	1150	1200	1250
L	460	510	560	610	660	710	760	810	860	910	960	1010	1060	1110	1160	1210	1260	1310	1360	1410	1460	1510	1560	1610
A	150	200	50	100	150	200	50	100	150	200	50	100	150	200	50	100	150	200	50	100	150	200	50	100
M	1	1	2	2	2	2	3	3	3	3	4	4	4	4	5	5	5	5	6	6	6	6	7	7
N	6	6	8	8	8	8	10	10	10	10	12	12	12	12	14	14	14	14	16	16	16	16	18	18
重量(kg)	15.4	16.4	17.4	18.4	19.4	20.4	21.4	22.4	23.4	24.4	25.4	26.4	27.4	28.4	29.4	30.4	31.4	32.4	33.4	34.4	35.4	36.4	37.4	38.4

※本公司享有變更規格之權益，恕不另行通知 ※Drawings and specifications are subject to change without prior notice.

# M4

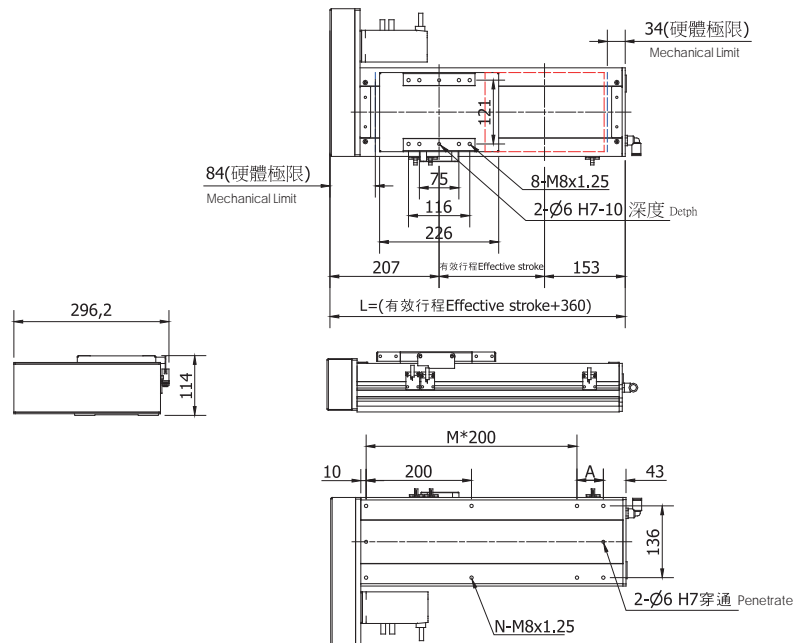

行程 Stroke	100	150	200	250	300	350	400	450	500	550	600	650	700	750	800	850	900	950	1000	1050	1100	1150	1200	1250
L	460	510	560	610	660	710	760	810	860	910	960	1010	1060	1110	1160	1210	1260	1310	1360	1410	1460	1510	1560	1610
A	150	200	50	100	150	200	50	100	150	200	50	100	150	200	50	100	150	200	50	100	150	200	50	100
M	1	1	2	2	2	2	3	3	3	3	4	4	4	4	5	5	5	5	6	6	6	6	7	7
N	6	6	8	8	8	8	10	10	10	10	12	12	12	12	14	14	14	14	16	16	16	16	18	18
重量(kg)	15.4	16.4	17.4	18.4	19.4	20.4	21.4	22.4	23.4	24.4	25.4	26.4	27.4	28.4	29.4	30.4	31.4	32.4	33.4	34.4	35.4	36.4	37.4	38.4

※本公司享有變更規格之權益，恕不另行通知 ※Drawings and specifications are subject to change without prior notice.

## M5

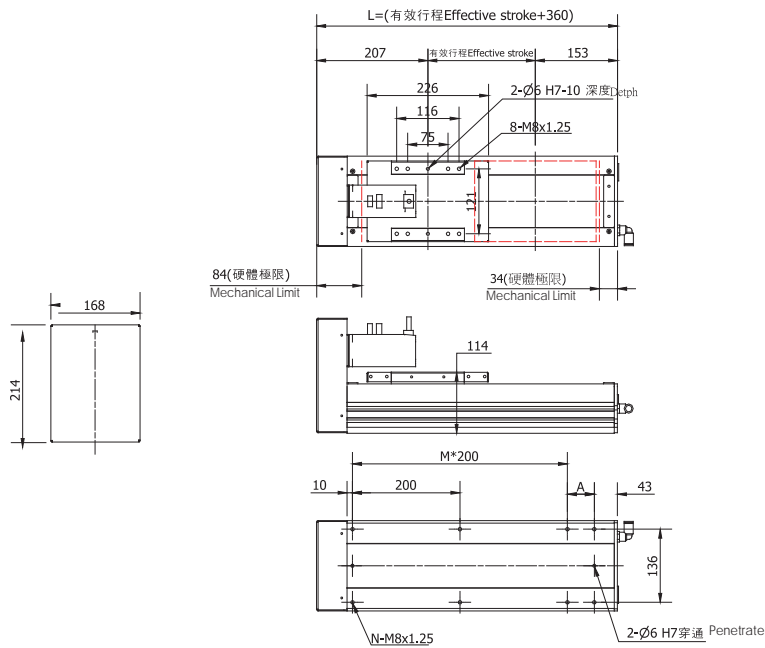

行程 Stroke	100	150	200	250	300	350	400	450	500	550	600	650	700	750	800	850	900	950	1000	1050	1100	1150	1200	1250
L	460	510	560	610	660	710	760	810	860	910	960	1010	1060	1110	1160	1210	1260	1310	1360	1410	1460	1510	1560	1610
A	150	200	50	100	150	200	50	100	150	200	50	100	150	200	50	100	150	200	50	100	150	200	50	100
M	1	1	2	2	2	2	3	3	3	3	4	4	4	4	5	5	5	5	6	6	6	6	7	7
N	6	6	8	8	8	8	10	10	10	10	12	12	12	12	14	14	14	14	16	16	16	16	18	18
重量(kg)	15.4	16.4	17.4	18.4	19.4	20.4	21.4	22.4	23.4	24.4	25.4	26.4	27.4	28.4	29.4	30.4	31.4	32.4	33.4	34.4	35.4	36.4	37.4	38.4

※本公司享有變更規格之權益，恕不另行通知 ※Drawings and specifications are subject to change without prior notice.

## M6

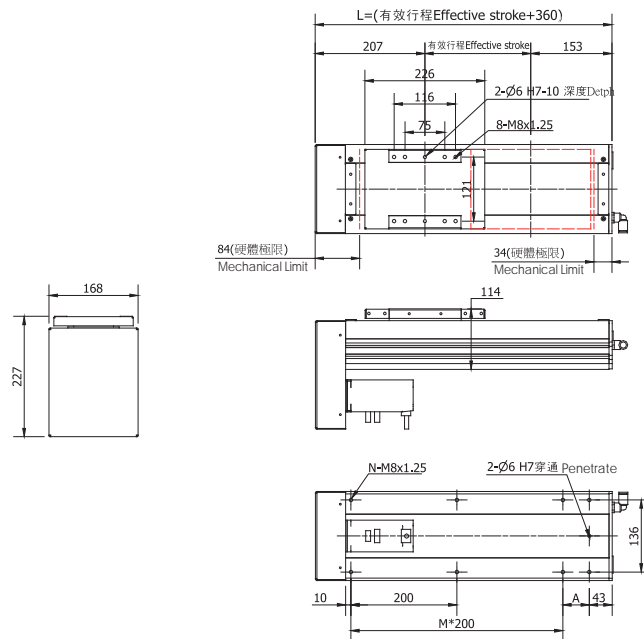

行程 Stroke	100	150	200	250	300	350	400	450	500	550	600	650	700	750	800	850	900	950	1000	1050	1100	1150	1200	1250
L	460	510	560	610	660	710	760	810	860	910	960	1010	1060	1110	1160	1210	1260	1310	1360	1410	1460	1510	1560	1610
A	150	200	50	100	150	200	50	100	150	200	50	100	150	200	50	100	150	200	50	100	150	200	50	100
M	1	1	2	2	2	2	3	3	3	3	4	4	4	4	5	5	5	5	6	6	6	6	7	7
N	6	6	8	8	8	8	10	10	10	10	12	12	12	12	14	14	14	14	16	16	16	16	18	18
重量(kg)	15.4	16.4	17.4	18.4	19.4	20.4	21.4	22.4	23.4	24.4	25.4	26.4	27.4	28.4	29.4	30.4	31.4	32.4	33.4	34.4	35.4	36.4	37.4	38.4

※本公司享有變更規格之權益，恕不另行通知 ※Drawings and specifications are subject to change without prior notice.