

CNK8-L10-S100-M2-M200W-B

型號 Model 導程 Lead 行程 Stroke 馬達方向 Motor direction 馬達廠牌及出力 Model brand and output 剎車 Brake

M2 馬達外置 Motor outside position
 M3 馬達外置右側 Motor outside ,rightward position
 M4 馬達外置左側 Motor outside , left ward position
 M6 馬達外置下方 Motor outside ,lower position

H 上銀 Hiwin
 X 西門子 Siemens
 M 三菱 Mitsubishi
 Y 安川 Yaskawa
 P 松下 Panasonic
 F 富士 Fuji
 T 台達 Delta

CNK8規格表(CNK8 Specification)

馬達出力 Step motor output	200W			
重複定位精度 Repeatability(mm)	±0.01			
滾珠絲桿外徑 B.SØ	Ø16			
滾珠螺桿導程 Lead(mm)	5	10	20	
最快速度 Maximun speed(mm/sec)	250	500	1000	
最大載重 Maximun payload(kg)	水平使用 (H)	50	30	11
	垂直使用 (V)	15	8	2.6
額定推力 Rated thrus(N)	685	340	176	
行程 Stroke(mm)	100-1050 50間隔 (interval)			

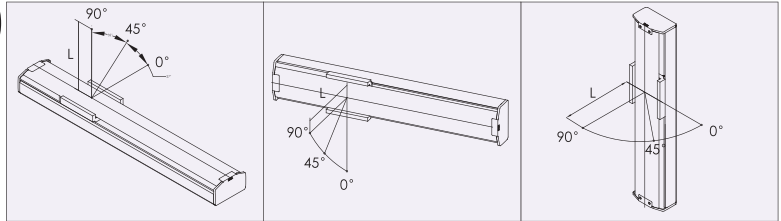

水平安裝應用: 單位Unit:mm Horizontal use					牆面安裝應用: 單位Unit:mm Wall installation use					垂直安裝應用: 單位Unit:mm During vertical use				
導程 Lead	荷重 Payload	0°	45°	90°	導程 Lead	荷重 Payload	0°	45°	90°	導程 Lead	荷重 Payload	0°	45°	90°
Lead20	6kg	467	390	1180	Lead20	6kg	760	423	386	Lead20	2.5kg	863	460	863
	9kg	325	262	800		9kg	542	290	234		-	-	-	-
	12kg	238	183	595		12kg	277	180	159		-	-	-	-
Lead10	10kg	415	293	1700	Lead10	10kg	1360	378	286	Lead10	5kg	583	270	583
	20kg	202	200	823		20kg	794	173	136		8kg	340	170	340
	30kg	131	113	483		30kg	493	106	86		-	-	-	-
Lead05	20kg	302	283	1532	Lead05	20kg	1450	214	153	Lead05	10kg	361	245	361
	35kg	146	136	882		35kg	845	113	81		15kg	234	156	234
	50kg	90	78	430		50kg	463	74	53		-	-	-	-

*滑塊表面中心到搬送物重心的距離(僅供參考)
 Distance center of slider top to center of gravity of object being transported (For reference only)

靜態容許負載慣量
Stidic Loading Moment

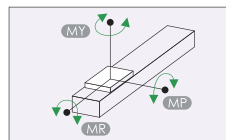

(單位:N.m) (Unit:N.m)

水平使用時 Static Loading Moment

MY	320
MP	320
MR	630

"此款型號不建議當多軸負載軸"
 This model suggest not be used as load axis of multi axes.

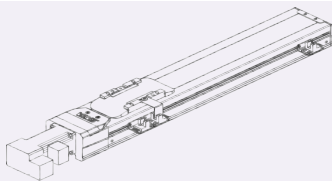

M2

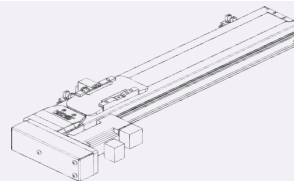

M3

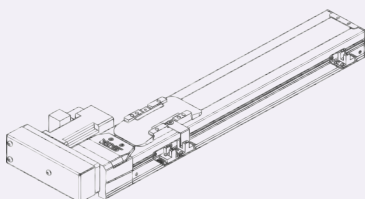

M4

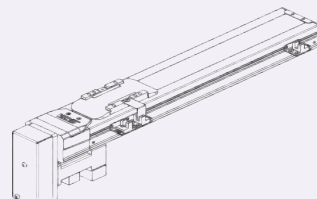

M6

M2

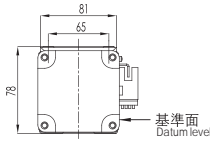

局部視圖B
Local view

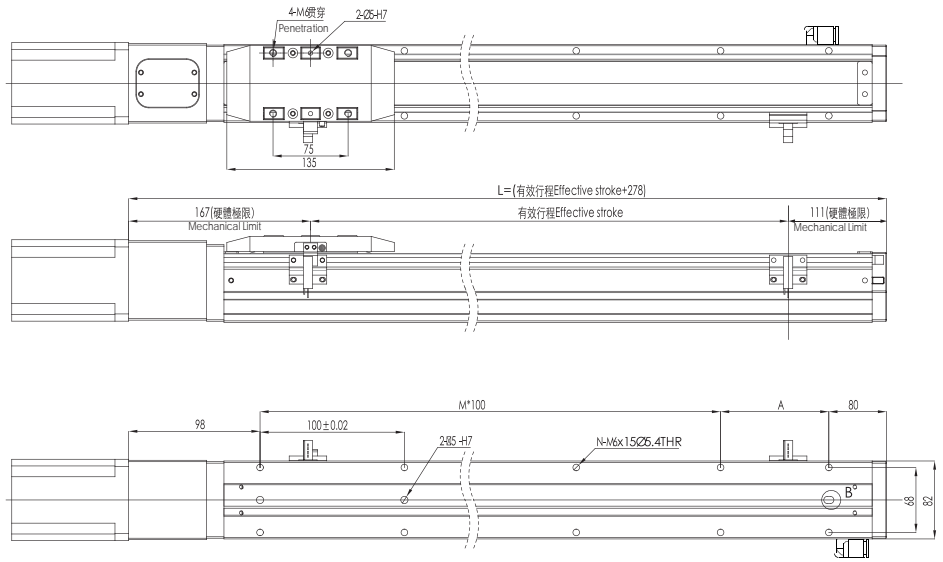
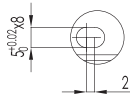

行程 Stroke	100	150	200	250	300	350	400	450	500	550	600	650	700	750	800	850	900	950	1000	1050
L	378	428	478	528	578	628	678	728	778	828	878	928	978	1028	1078	1128	1178	1228	1278	1328
A	100	50	100	50	100	50	100	50	100	50	100	50	100	50	100	50	100	50	100	50
M	1	2	2	3	3	4	4	5	5	6	6	7	7	8	8	9	9	10	10	11
N	6	8	8	10	10	12	12	14	14	16	16	18	18	20	20	22	22	24	24	26
質量(kg)	5.54	5.91	6.27	6.64	7	7.37	7.73	8.1	8.46	8.83	9.19	9.56	9.92	10.29	10.65	11.02	11.38	11.75	12.11	12.48

※本公司享有變更規格之權益，恕不另行通知 ※Drawings and specifications are subject to change without prior notice.

M3

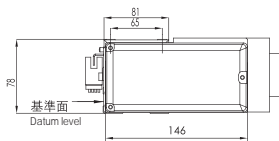

局部視圖B
Local view

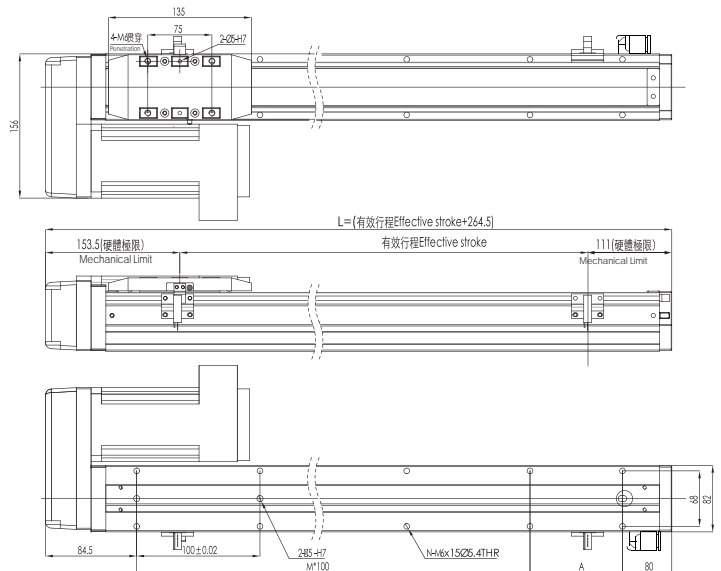

行程 Stroke	100	150	200	250	300	350	400	450	500	550	600	650	700	750	800	850	900	950	1000	1050
L	364.5	414.5	464.5	514.5	564.5	614.5	664.5	714.5	764.5	814.5	864.5	914.5	964.5	1014.5	1064.5	1114.5	1164.5	1214.5	1264.5	1314.5
A	100	50	100	50	100	50	100	50	100	50	100	50	100	50	100	50	100	50	100	50
M	0	1	1	2	2	3	3	4	4	5	5	6	6	7	7	8	8	9	9	10
N	4	6	6	8	8	10	10	12	12	14	14	16	16	18	18	20	20	22	22	24
質量(kg)	5.6	6.12	6.64	7.16	7.68	8.2	8.72	9.24	9.76	10.28	10.8	11.32	11.84	12.36	12.88	13.4	13.92	14.44	14.96	15.48

※本公司享有變更規格之權益，恕不另行通知 ※Drawings and specifications are subject to change without prior notice.

M4

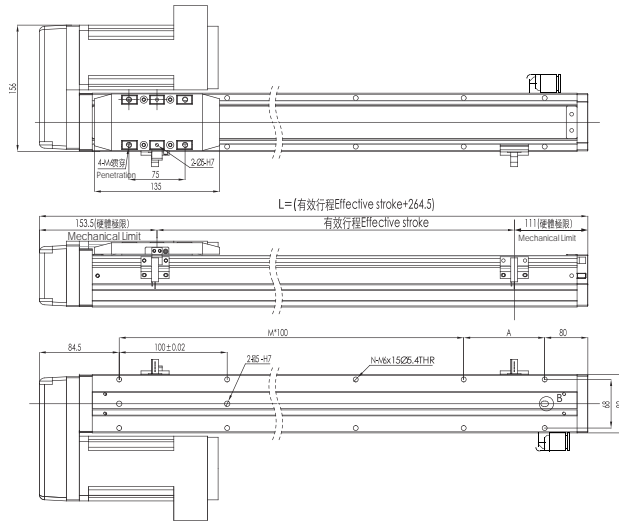
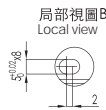
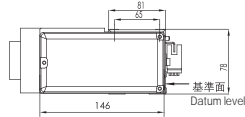

行程 Stroke	100	150	200	250	300	350	400	450	500	550	600	650	700	750	800	850	900	950	1000	1050
L	364.5	414.5	464.5	514.5	564.5	614.5	664.5	714.5	764.5	814.5	864.5	914.5	964.5	1014.5	1064.5	1114.5	1164.5	1214.5	1264.5	1314.5
A	100	50	100	50	100	50	100	50	100	50	100	50	100	50	100	50	100	50	100	50
M	0	1	1	2	2	3	3	4	4	5	5	6	6	7	7	8	8	9	9	10
N	4	6	6	8	8	10	10	12	12	14	14	16	16	18	18	20	20	22	22	24
質量 (kg)	5.6	6.12	6.64	7.16	7.68	8.2	8.72	9.24	9.76	10.28	10.8	11.32	11.84	12.36	12.88	13.4	13.92	14.44	14.96	15.48

※本公司享有變更規格之權益，恕不另行通知 ※Drawings and specifications are subject to change without prior notice.

M6

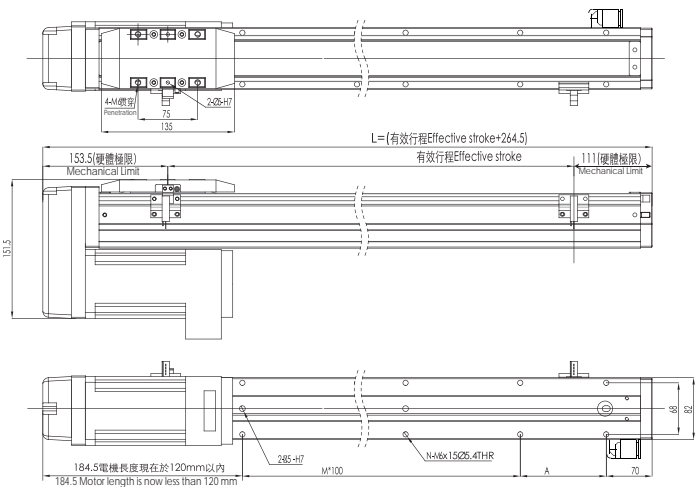
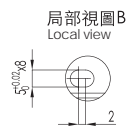
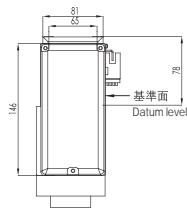

行程 Stroke	100	150	200	250	300	350	400	450	500	550	600	650	700	750	800	850	900	950	1000	1050
L	364.5	414.5	464.5	514.5	564.5	614.5	664.5	714.5	764.5	814.5	864.5	914.5	964.5	1014.5	1064.5	1114.5	1164.5	1214.5	1264.5	1314.5
A	100	50	100	50	100	50	100	50	100	50	100	50	100	50	100	50	100	50	100	50
M	0	1	1	2	2	3	3	4	4	5	5	6	6	7	7	8	8	9	9	10
N	4	6	6	8	8	10	10	12	12	14	14	16	16	18	18	20	20	22	22	24
質量 (kg)	5.6	6.12	6.64	7.16	7.68	8.2	8.72	9.24	9.76	10.28	10.8	11.32	11.84	12.36	12.88	13.4	13.92	14.44	14.96	15.48

※本公司享有變更規格之權益，恕不另行通知 ※Drawings and specifications are subject to change without prior notice.