

CB100D-YL40 - S1850 - B1 - M 200W - B

型號 Model	孔型與每轉移動量 Hole type and movement per revolution	行程 Stroke	馬達方向 Motor direction	馬達廠牌及出力 Motor brand and output	煞車 Brake
	Y 底部牙孔 Thread hole		馬達方向 Motor direction B1 馬達左折上端 Motor leftward, upper position B2 馬達右折上端 Motor rightward, upper position B3 馬達左折水平 Motor leftward, horizontal position B4 馬達右折水平 Motor rightward, horizontal position B5 馬達左折下端 Motor leftward, lower position B6 馬達右折下端 Motor rightward, lower position	馬達廠牌及出力 Motor brand and output H 上銀 Hiwin X 西門子 Siemens M 三菱 Mitsubishi Y 安川 Yaskawa P 松下 Panasonic F 富士 Fuji T 台達 Delta	

CB100D規格表(CB100D Specification):

馬達出力 AC Servo motor output(W)	100W	200W
重覆定位精度 Repeatability(mm)	±0.04	±0.04
每轉移動量 Equivalent to lead(mm)	39.9939	39.9939
最大載重 Maximun payload(kg)	20	25
最快速度 Maximun speed(mm/sec)	2000	
行程 Stroke(mm)	150~1850 100間隔 (interval)	

線性滑軌12x8-2支 (Linear Guide12x8-2)

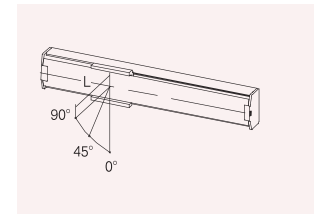
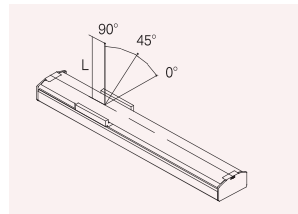

水平安裝應用(單位:mm) Horizontal use			
	90°	45°	0°
5kg	800	525	509
15kg	427	290	208
20kg	229	186	122
25kg	130	69	37

牆面安裝應用(單位:mm) Wall installation use			
	90°	45°	0°
5kg	433	401	727
11kg	316	290	503
18kg	144	116	200
25kg	0	36	71

*滑塊表面中心到搬送物重心的距離(僅供參考)
Distance center of slider top to center of gravity of object being transported (For reference only)

靜態容許負載慣量
Stidic Loading Moment

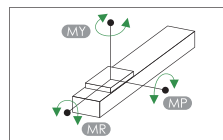

(單位:N.m) (Unit:N.m)
水平使用時 Static Loading Moment

MY	150
MP	150
MR	130

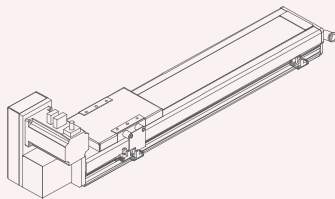

B1

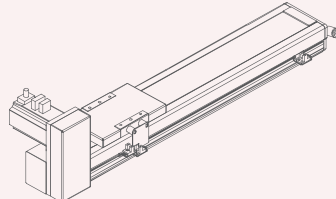

B2

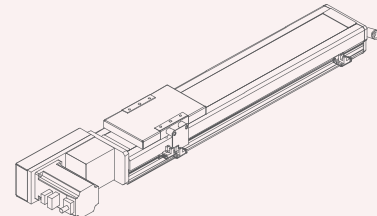

B3

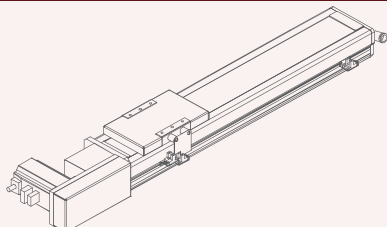

B4

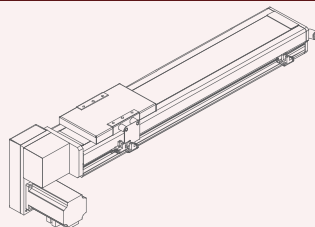

B5

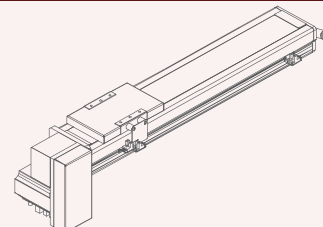

B6

B1

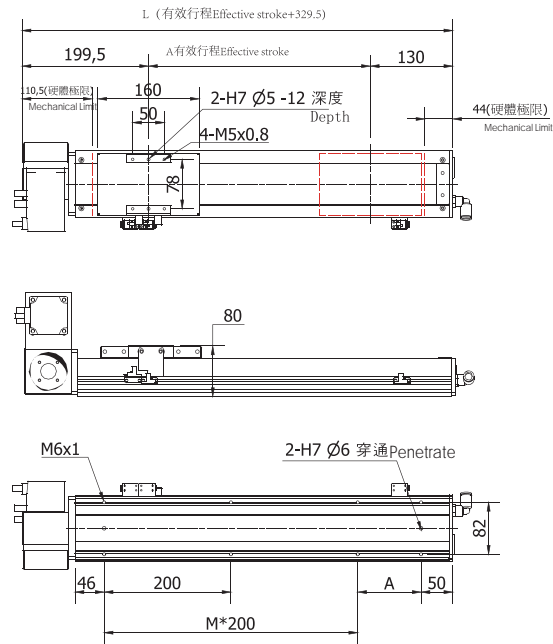
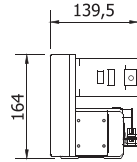

行程 Stroke	150	250	350	450	550	650	750	850	950	1050	1150	1250	1350	1450	1550	1650	1750	1850
L	479.5	579.5	679.5	779.5	879.5	979.5	1079.5	1179.5	1279.5	1379.5	1479.5	1579.5	1779.5	1879.5	1979.5	2079.5	2179.5	2279.5
A	100	200	100	200	100	200	100	200	100	200	100	200	100	200	100	200	100	200
M	1	1	2	2	3	3	4	4	5	5	6	6	7	7	8	8	9	9
N	6	6	8	8	10	10	12	12	14	14	16	16	18	18	20	20	22	22
重量(kg)	6.2	6.9	7.6	8.3	9.0	9.7	10.4	11.1	11.8	12.5	13.2	13.9	14.6	15.3	16.0	16.7	17.4	18.1

※本公司享有變更規格之權益，恕不另行通知 ※Drawings and specifications are subject to change without prior notice.

B2

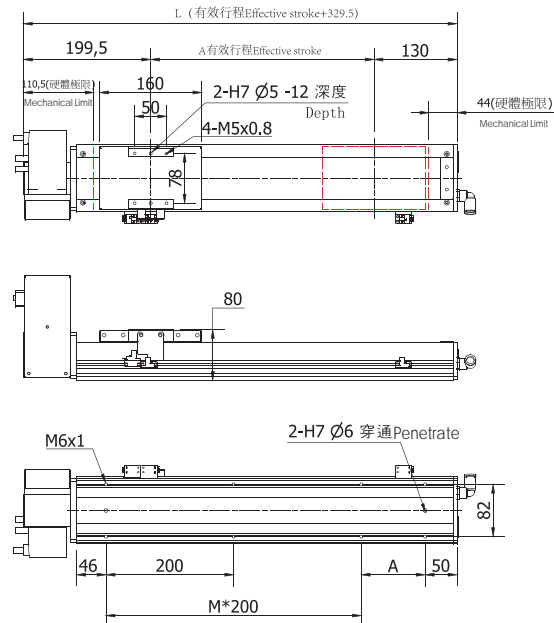
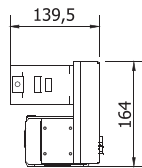

行程 Stroke	150	250	350	450	550	650	750	850	950	1050	1150	1250	1350	1450	1550	1650	1750	1850
L	479.5	579.5	679.5	779.5	879.5	979.5	1079.5	1179.5	1279.5	1379.5	1479.5	1579.5	1779.5	1879.5	1979.5	2079.5	2179.5	2279.5
A	100	200	100	200	100	200	100	200	100	200	100	200	100	200	100	200	100	200
M	1	1	2	2	3	3	4	4	5	5	6	6	7	7	8	8	9	9
N	6	6	8	8	10	10	12	12	14	14	16	16	18	18	20	20	22	22
重量(kg)	6.2	6.9	7.6	8.3	9.0	9.7	10.4	11.1	11.8	12.5	13.2	13.9	14.6	15.3	16.0	16.7	17.4	18.1

※本公司享有變更規格之權益，恕不另行通知 ※Drawings and specifications are subject to change without prior notice.

B3

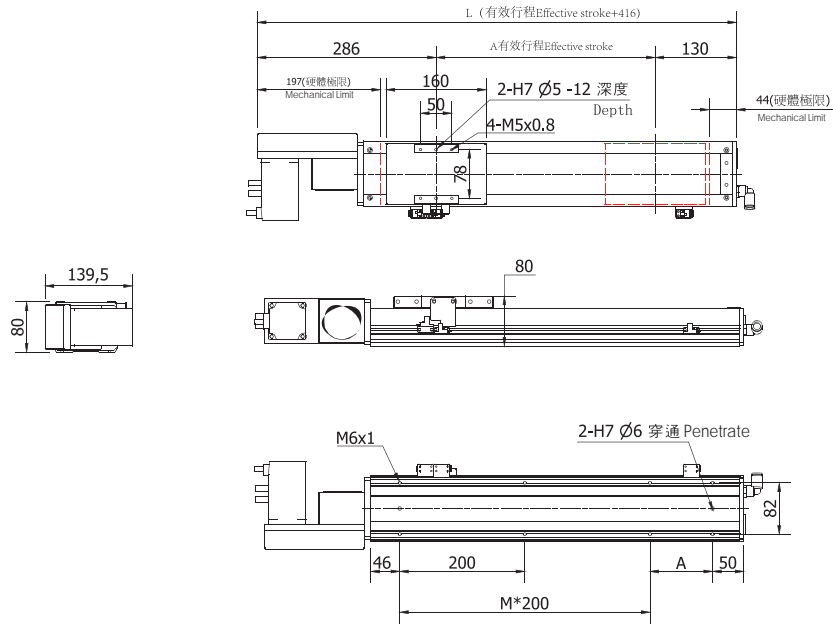

行程 Stroke	150	250	350	450	550	650	750	850	950	1050	1150	1250	1350	1450	1550	1650	1750	1850
L	567	667	767	867	967	1067	1167	1267	1367	1467	1567	1667	1767	1867	1967	2067	2167	2267
A	100	200	100	200	100	200	100	200	100	200	100	200	100	200	100	200	100	200
M	1	1	2	2	3	3	4	4	5	5	6	6	7	7	8	8	9	9
N	6	6	8	8	10	10	12	12	14	14	16	16	18	18	20	20	22	22
重量(kg)	6.2	6.9	7.6	8.3	9.0	9.7	10.4	11.1	11.8	12.5	13.2	13.9	14.6	15.3	16.0	16.7	17.4	18.1

※本公司享有變更規格之權益，恕不另行通知 ※Drawings and specifications are subject to change without prior notice.

B4

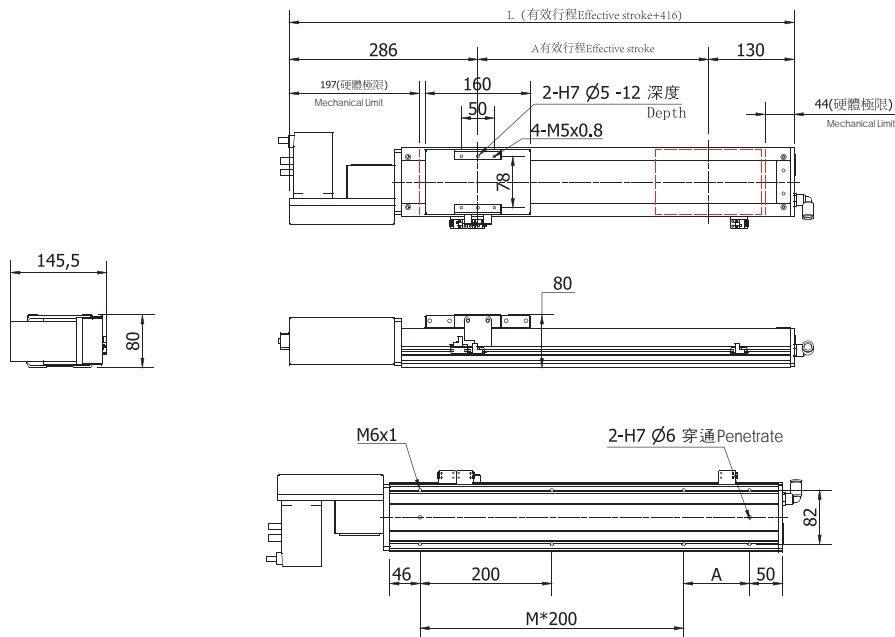

行程 Stroke	150	250	350	450	550	650	750	850	950	1050	1150	1250	1350	1450	1550	1650	1750	1850
L	567	667	767	867	967	1067	1167	1267	1367	1467	1567	1667	1767	1867	1967	2067	2167	2267
A	100	200	100	200	100	200	100	200	100	200	100	200	100	200	100	200	100	200
M	1	1	2	2	3	3	4	4	5	5	6	6	7	7	8	8	9	9
N	6	6	8	8	10	10	12	12	14	14	16	16	18	18	20	20	22	22
重量(kg)	6.2	6.9	7.6	8.3	9.0	9.7	10.4	11.1	11.8	12.5	13.2	13.9	14.6	15.3	16.0	16.7	17.4	18.1

※本公司享有變更規格之權益，恕不另行通知 ※Drawings and specifications are subject to change without prior notice.

B5

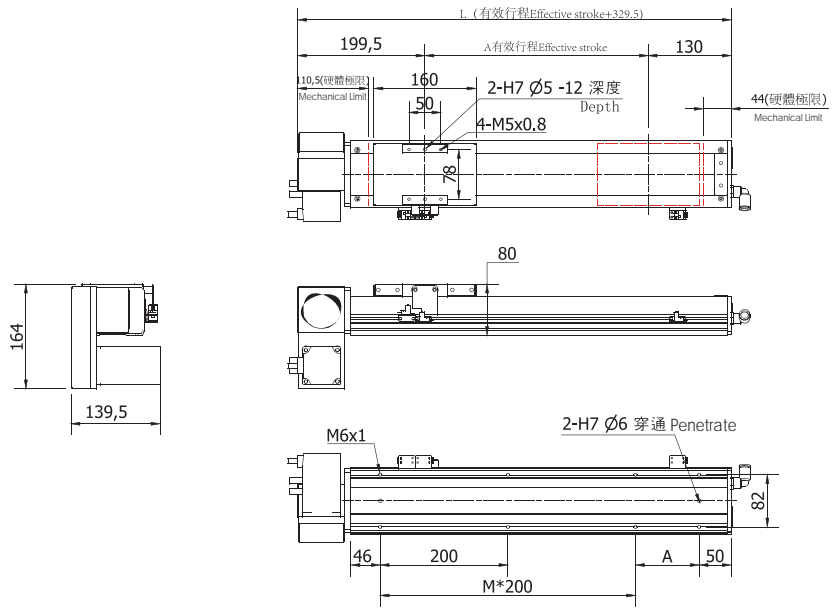

行程 Stroke	150	250	350	450	550	650	750	850	950	1050	1150	1250	1350	1450	1550	1650	1750	1850
L	479.5	579.5	679.5	779.5	879.5	979.5	1079.5	1179.5	1279.5	1379.5	1479.5	1579.5	1779.5	1879.5	1979.5	2079.5	2179.5	2279.5
A	100	200	100	200	100	200	100	200	100	200	100	200	100	200	100	200	100	200
M	1	1	2	2	3	3	4	4	5	5	6	6	7	7	8	8	9	9
N	6	6	8	8	10	10	12	12	14	14	16	16	18	18	20	20	22	22
重量(kg)	6.2	6.9	7.6	8.3	9.0	9.7	10.4	11.1	11.8	12.5	13.2	13.9	14.6	15.3	16.0	16.7	17.4	18.1

※本公司享有變更規格之權益，恕不另行通知 ※Drawings and specifications are subject to change without prior notice.

B6

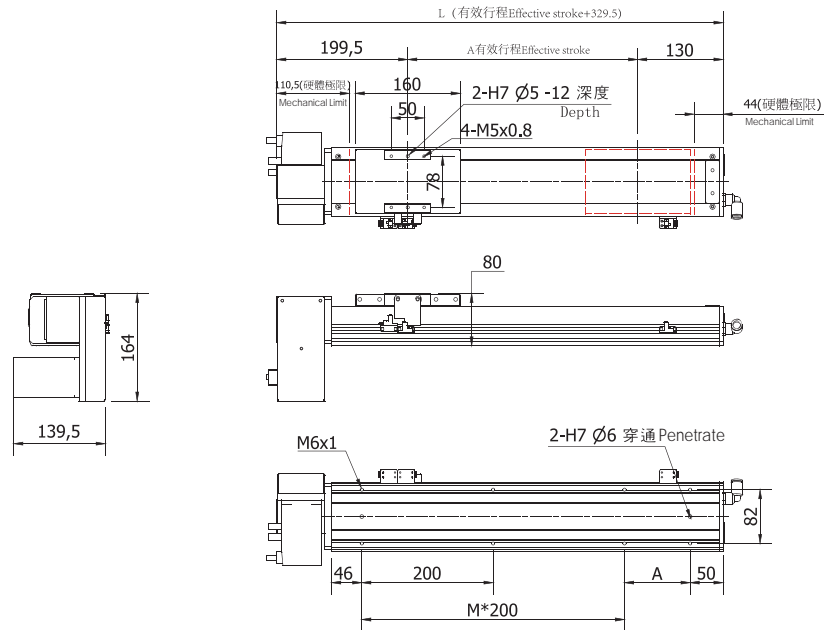

行程 Stroke	150	250	350	450	550	650	750	850	950	1050	1150	1250	1350	1450	1550	1650	1750	1850
L	479.5	579.5	679.5	779.5	879.5	979.5	1079.5	1179.5	1279.5	1379.5	1479.5	1579.5	1779.5	1879.5	1979.5	2079.5	2179.5	2279.5
A	100	200	100	200	100	200	100	200	100	200	100	200	100	200	100	200	100	200
M	1	1	2	2	3	3	4	4	5	5	6	6	7	7	8	8	9	9
N	6	6	8	8	10	10	12	12	14	14	16	16	18	18	20	20	22	22
重量(kg)	6.2	6.9	7.6	8.3	9.0	9.7	10.4	11.1	11.8	12.5	13.2	13.9	14.6	15.3	16.0	16.7	17.4	18.1

※本公司享有變更規格之權益，恕不另行通知 ※Drawings and specifications are subject to change without prior notice.