



## Rapid Product Assessment Solar Milling Test Method

### Table of Contents

<b>Introduction</b> .....	2
<b>Context</b> .....	2
<b>Scope</b> .....	2
<b>Definitions</b> .....	3
<b>Abbreviations</b> .....	4
<b>Test Summary</b> .....	5
<b>Test Procedure</b> .....	8
Visual Inspection.....	8
Product Safety.....	10
Performance Testing.....	11
Temperature.....	13
Vibration.....	13
Texture of Flour.....	13
<b>References</b> .....	14
<b>Annex 1 – Types of Mills</b> .....	15

## Introduction

The Rapid Product Assessment Solar Milling Test Method evaluates solar-powered milling equipment intended for deployment in stand-alone applications. The tests include procedures for checking quality, performance, and safety. [Kijani Testing](#) developed the testing protocol with CLASP in support of [VeraSol](#), a quality assurance program for off-grid solar solutions.

## Context

Grains are the most frequently produced and consumed food crop in the Global South, and milling is critical to processing these grains for sale and consumption. However, milling is labour-intensive, especially for women in rural households who are typically tasked with the chore. It takes about 30 minutes to grind a kilogram of flour by hand; in comparison, using a conventional hammermill takes less than 70 seconds.<sup>1</sup>

Presently, large-scale diesel mills dominate the off-grid market. In Sub-Saharan Africa and South Asia, the low rate of electrification and lack of reliable electricity access has led to the continued widespread use of diesel engines for milling. The solar-powered mill is a promising technology solution that helps rural farmers and households reduce drudgery and increase farm productivity while mitigating diesel mills' health and environmental impacts.

Currently, there are no universally accepted test methods to measure and evaluate milling performance consistently. As a first step to help the off-grid sector standardise solar mill performance measurements, this test method describes a testing process for solar mills and defines relevant metrics for market actors to benchmark and compare the performance and quality of solar mills.

## Scope

This document defines methods to evaluate the quality, performance, functionalities, and user safety of small-scale (less than 2.2 kilowatts of power input required and with throughputs of less than 200 kilograms per hour) solar-powered milling equipment used mainly for agricultural processing to break grains into smaller particles.<sup>2</sup>

The test method consists of the following major components:

- Overall **product quality** inspection, both internal and external, as well as an evaluation of the user manual and manufacturer-provided information
- General assessment of **safety for users**

---

<sup>1</sup> Smith, A. (1995). Design of a Screenless Hammermill (Unpublished master's thesis). Massachusetts Institute of Technology.

<sup>2</sup> Efficiency for Access, 2021. Solar Appliance Technology Brief: Milling.

- Evaluation of product **performance**, including energy performance and service delivery

## Definitions

### Grain Milling

Grain milling refers to grinding grains into flour or meal for human or animal consumption. By applying manual or mechanical forces to break the exterior structure of the grain through cutting, crushing, or grinding, the milling process turns solid grains into finer particles of different textures, such as flour.<sup>3</sup>

### Electric Milling Machine

A milling machine is a device that breaks solid materials into smaller pieces by grinding, crushing, or cutting. All mechanical mills have a power source that drives a particle reduction mechanism. The milling machine comprises the following major components: frame, electric motor, hopper, and milling compartment (e.g., hammer and screen).

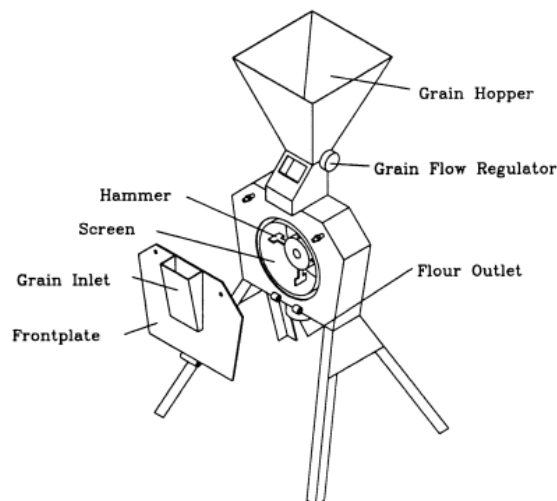

**FIGURE 1: A DIAGRAM OF COMPONENTS IN A CONVENTIONAL HAMMER MILL<sup>4</sup>**

---

<sup>3</sup> Kawuyo, U. A., Chinese, M. N., Ahmad, A. B., & Amune, E. O. (august 2014). Grain milling machine. Part 1: Design and construction. *Arid Zone Journal of Engineering, Technology and Environment*, 10, 75-84. Retrieved from [https://www.academia.edu/30542217/GRAIN\\_MILLING\\_MACHINE\\_PAPER\\_I\\_DESIGN\\_AND\\_CONSTRUCTION](https://www.academia.edu/30542217/GRAIN_MILLING_MACHINE_PAPER_I_DESIGN_AND_CONSTRUCTION)

<sup>4</sup> Ibid.

## **Solar Powered Milling Machine**

A subset of electricity mills, driven by a motor powered by a standalone solar PV system, with batteries and inverters as optional components.

## **Abbreviations**

W	Watt, S.I unit for power
Hz	Hertz, one cycle per second, S.I unit for frequency
mm	Millimetre
RPM	Revolutions per minute
A	Amps, S.I unit for current
db	Decibel

## Test Summary

The following testing metrics were developed to evaluate the milling machine.

PARAMETER	METRICS	DESCRIPTION	UNITS OF MEASURE
<b>Quality Visual Inspection</b>	Consumer-facing information	Document the basic product information, user manuals, warranty information, product packaging and product condition on arrival.	Good/ Satisfactory/ Needs improvement/ Poor
	Grain moisture content	Is there a disclaimer on the user manual to only mill dry grains?	Yes/No
	End-use function (e.g., spice grinder, rice mill, community mill):	These definitions are helpful to contextualize the mills and in consumer-facing applications. Has the end use function been described in the manual?	Yes/No
<b>Safety</b>	Electrical shock and insulation test	Test if any leakage of electrical current may go through the body due to poor insulation or breakdown of components between the live and neutral lines of the milling machine. It is done using a phase tester and when the milling machine is plugged into a 240V mains supply.	Mega ohm (MΩ)
	Exposed parts that might cause bodily harm	Check for protection against rotating parts that might cause bodily harm. Are all rotating parts covered?	Yes/No
	On and off switch	Check placement of on and off switch. Is it easily accessible?	Yes/No
	Noise	Measure the noise levels of the milling machine when running without load and when under load. Noise produced by the milling machine should be within the accepted standard not to cause environmental harm. Acceptable	Decibels (dB) <sup>8</sup>

---

<sup>8</sup> Sound intensity is measured in decibels.

		standards by NEMA vary between 35–40 dB for silent zones, 35–45 db for residential areas and 35–60 dB for commercial areas. <sup>5</sup> If the noise level of a machine exceeds 70db, it must be specified in the user manual. <sup>6</sup> Noise above 70db require noise protection equipment. <sup>7</sup>	
	Vibration	Measure the amount of vibration produced by the milling machine. This is done to establish whether the machine can cause damage to the ground on which it has been installed or even move when not securely mounted in position. Vibration up to 0.71mm/s is considered acceptable for small machine (<20hp) and do not require rigid foundations. <sup>9</sup>	Millimeter per seconds (mm/s)
	Temperature	Measure the temperature of the milling machine body when in operation. Thermocouples are placed at different positions on the body of the milling machine and temperature is measured at specified intervals when the motor is running. Temperatures over 55° can cause minor burns and are not recommended. <sup>10</sup>	Celsius (°C)
<b>Performance</b>	Speed of motor and spindle	Test focuses on the motor's efficacy in transferring energy through the flywheel to the spindle and eventually cutting.	Revolutions per minute (RPM)

<sup>5</sup> [https://nema.go.ug/sites/all/themes/nema/docs/noise\\_standards\\_and\\_control\\_regulations.pdf](https://nema.go.ug/sites/all/themes/nema/docs/noise_standards_and_control_regulations.pdf)

<sup>6</sup> 2006/42/EC

<sup>7</sup> <https://www.osha.gov/laws-regs/regulations/standardnumber/1910/1910.95>

<sup>9</sup> ISO 10816- 3

<sup>10</sup> ISO 13732-1:2006

Power Input	Measure the power input of the machine when milling in different mode-settings. Measured power input is compared with the manufacturer-claimed input.	Kilowatts (kW)
Energy Consumption	Measure the amount of energy used over time when milling in different mode-settings.	Watt-hour (Wh)
Throughput/ Feed rate <sup>11</sup>	Measure the milling speed based on the screen size and the size of the feed aperture opening, typically recorded in kg/hour.  This is the <b>primary performance metric</b> for mills.	Kg/hour
Efficiency	This the energy consumed by the machine to mill one kg of grain.	Wh/kg
Performance in Low Solar Irradiance Condition	Test how the system performs in low solar irradiance conditions (200W/m <sup>2</sup> -400W/m <sup>2</sup> ). Solar panels are tested using standard test conditions (STC) which are 1000w/m <sup>2</sup> , this test is to monitor performance in settings below this.	Watts per square meter (W/m <sup>2</sup> )
Full battery capacity	Measure battery capacity when fully charged.	Ampere hour (AH)
Full battery run time	Measure the amount of time it takes to drain a fully charged battery.	Time in Hours (Hrs)

---

<sup>11</sup> <https://mail.google.com/mail/u/1/#inbox/FMfcgzGmthnjTCjQwZcZWGNplcNWsxfj?projector=1&messagePartId=0.1>

## Test Procedure

This test procedure aims to evaluate the milling machine's quality performance, safety and ability to meet the end-user needs or requirements. This also aims to assess and confirm the manufacturer's performance and technical indexes as disclosed in the user manual when the milling machine is tested.

The test uses the following equipment:

- Phase Tester
- Decibel meter
- Vibration meter
- Sieves
- Mechanical shaker
- K-type Thermocouple
- Temperature data logger
- Scale
- Tachometer
- Ruler

### 1. Visual inspection

#### 1.1 Milling machine specification

Upon delivery, check for the following in the manufacturer's specification sheet or user manual:

- Brand Name
- Model Name
- Manufacturer and supplier
- Certification number
- Power Supply Type
- Rated Input Voltage [V] and power consumption (W)
- Frequency [Hz]
- The type of milling machine, type of milling teeth and the disc milling screen
- Product accompanying parts
- Production capacity
- Holding capacity
- Rated spindle speed
- Size of motor (Hp)
- The measurements of the body and the general structure(mm)

#### 1.2 Capture photographs of the:

- The packaging, if available



- Front/ back and sides of the milling machine
- Photos of the labels
- Name plate of the motor
- Protective cover of the belt
- Control box
- Front cover of user manual booklet, if provided

### 1.3 Marking and Labelling

Inspect the milling machine for the information provided in the table below and check as Yes or No if present or not and if the label is resistant to removal or not.

Specification	Is the marking present		Value	Are the markings substantially resistant to removal?	
	Yes	No		Yes	No
Manufacturer or distributor					
Identification number, Identification of the series or batch or manufacturing number					
Year of manufacture					
Capacity					
Voltage					
Frequency					
Power					
RPM of motor					
Single/ 3 phase type					
Handling information					
Safety Information					

### 1.4 Rate for presence, clarity and relevance of the marking and labelling as;

- **Good** – All labels specified are present and are resistant to removal.
- **Satisfactory** – Most labels specified are present and resistant to removal.
- **Needs Improvement** – Less than half of the labels are missing on the product, and markings can easily be removed.
- **Poor** – No labels or markings.

### 1.5 Record any additional comments and observations made.

## 2. Product Safety

2.1 Inspect cables and fill in the information provided in the table below; for insulation quality of cables, exposed cables or any other part of the circuit that can be hazardous.

Size of cable (mm <sup>2</sup> )	
Maximum temperature (°C)	
Maximum voltage (V)	
Maximum current (I)	
Quality of insulation	Good (insulation sheath (material) is thick and strong enough and cannot be pricked by nail to expose wires at all)
	Fair (Insulation sheath can cannot be pricked easily to exposure the wires)
	Poor (is easily pricked, insulation sheath is light and breaks when twisted)

2.2 Check safety warning signs, comment on visibility and clarity as:

- **Good** – Safety markings are present and correctly positioned, stickers and writings are visible, and the message is easily understood
- **Fair** – Safety markings are present and correctly positioned, and the message is vague
- **Poor** – No markings, not visible, and the message cannot be understood

2.3 Check for the start/stop button functionality by manually turning it. Comment on whether the button is functional and easy to use.

2.4 Check if the milling machine has any mechanical safety isolation features. Comment on whether the safety isolation features are present or not. If present, state which one and how it works.

2.5 Check and confirm the motor wiring circuit to ensure it coincides with the manufacturer-provided circuit.

2.6 Check for any automatic isolation mechanism during operation. Comment on whether safety isolation features are present or not. If present, state which one and how it works.

2.7 Using a multimeter, check for the continuity of the contacts of the start/stop button and the contactor. Comment on whether they are correctly functioning.

2.8 Inspect for and list any cooling mechanisms.

2.9 Check for the structural design of the metallic parts of the milling machine and whether they can pose a risk to the handlers, operators or bystanders. Comment on the design and note any safety risks that are related to the design.

2.10 Check the machine's surface temperature around the motor and comment on how hot it gets.

### 3. Performance testing

#### 3.1 Pre-test Operation

- Set up the milling machine
- Set the manufacturer's specified operational parameters. Run the machine without load and check if the machine adequately operates within the stated parameters
- If not, make any adjustments needed
- Note the noise produced when operating without a load
- Note the motor's direction of rotation and confirm with the manufacturer's specification in the circuit
- Stop and allow the milling machine to cool before the next test procedures begin

#### 3.2 Input and Output Capacity Test

- Set up the milling machine, different screens, power loggers and speed measurement loggers
- Select 10kg of locally available dry maize
- check the grain hoppers carrying capacity
- Add 2kg (use a weighing scale to verify the quantity) of each grain at a time in the intake hopper
- Measure the hopper's carrying capacity
- Comment if the hopper intake is automatic or manual
- If manual, follow the instructions below: Start the machine and open the hopper intake valve by 25% to allow the grains into the milling compartment; note the time it takes to mill 2kg in this setting. Repeat for 50% and 100% opening.

#### 3.3 Speed of Milling

- Note the time when the first amount of milled flour comes out of the hopper at the bottom
- Note the amount of time taken to mill 2kg of grains
- Measure the weight of the flour obtained after milling
- Repeat the steps above with the other screen sizes
- Calculate the milling conversion and the throughput capacity using the following equations:

$$\text{Milling conversion} = \text{mass of milled maize(kg)}/\text{total mass of maize fed(kg)} * 100\% \dots\dots\dots$$

Eq. (1)

$$\text{Throughput capacity(kg/hr)} = \text{feed input(kg)}/\text{milling time(hr)} \dots\dots\dots\text{Eq. (2)}$$

### 3.4 Energy Requirements and Consumption

- Install a power logger and set up the milling machine to run for 30 minutes with a given amount of grains; using a clamp metre and multimeter, take the readings of the following parameters after an interval of 5 minutes.
  - Voltage (V)
  - Current (A)
  - Power (W)
  - Frequency (Hz)
- Measure the mass of the milled grain and record
- Tabulate the results, and from the data obtained, calculate:
  - Average power (W)
  - Energy consumed by the milling machine (Wh)
  - Energy efficiency (Wh/kg)
- Note the power variation for each screen size

### 3.4 Speed Motor and Spindle

- Speed of the motor is calculated using the following methods:
  - Method 1: In steps 3 and 4 above, calculate the speed of the motor and spindle while the milling machine is in operation
  - Method 2: Using an RPM metre, take the revolutions taken by the motor and spindle instantaneously and record your values
  - Compare the calculated and measured speed with the manufacturer's disclosed specifications

### 3.5 Noise Level

- Noise level of the milling machine is determined by the distance from which the milling sound can be heard.
- Record how far the sound is heard and the sound intensity in dB.

Distance (m)	Decibel (dB)
0.5	
2	
5	

## 4. Temperature

### 4.1 Test procedure:

- Obtain two omega k-type thermometers and data loggers
- Attach one thermocouple on the body of the milling machine, preferably where the user is likely to get into contact with other than the grain hopper
- Record the temperature values (°C) during the milling process.
- Check the values obtained against the manufacturer's set limits

## 5. Vibration

### 5.1 Test procedure:

- Attach vibration metre/ data loggers on the milling machine body.
- Take the values of the vibration:

	UNIT (m/s <sup>2</sup> ) <sup>12</sup>
When the machine is without load	
When milling	
When decelerating at the end of a milling process	

## 6. Texture of flour

### 6.1 Sieve Test

Attempts have been made to classify and define products of maize processing; however, there needs to be a globally recognised terminology for dry-milled maize products. The table below identifies the commonly accepted terms used according to particle size ranges for maize products.<sup>13</sup>

Flour type	Particle size
Coarse flour	1190–730 µm
Medium flour	730–420 µm
Fine flour	420–212 µm

---

<sup>12</sup> Exposure to vibration requires the measurement of vibration acceleration in meters per second squared (m/s<sup>2</sup>).

Acceleration is used as the unit because measuring acceleration provides information about the velocity and amplitude of vibration.

<sup>13</sup> Wingfield J. Dictionary of Milling Terms and Equipment. Leawood, Kansas: International Association of Operative Millers; 1989.

The sieve test differentiates the difference in texture of flour once milled by varying the sieves.

## 6.2 Test procedure:

- Weigh out 500g of the sample to sieve the test
- Use a selection of different-sized mesh sieves to suit the granulation of your products
- Ensure that each sieve that's placed in mechanical shaker
- Sieve for 5–10 minutes
- Weigh off the stock on top of each sieve as well as the fines in the sifter pan
- Repeat for 3 samples
- Fill the table below

Flour type	Particle size	Weight of sifted flour (g)	% granules
Coarse flour	1190–730 $\mu\text{m}$		
Medium flour	730–420 $\mu\text{m}$		
Fine flour	420–212 $\mu\text{m}$		

*Note: Texture of flour doesn't refer to flour quality since quality depends on customer's preferences which vary with different cultures.*

## References

1. The Uganda National Environment (Noise Standards And Control) Regulations, 2003 ([link](#)).
2. Directive 2006/42/EC - new machinery directive – European Agency for Safety and Health at Work ([link](#)).
3. 1910.95 Occupational Noise Exposure – Occupational Safety and Health Administration, United States Department of Labour ([link](#)).
4. Simplified Vibration Monitoring: ISO 10816-3 Guidelines ([link](#)).
5. ISO 13732-1:2006, Ergonomics of the thermal environment - Methods for the assessment of human responses to contact with surfaces ([link](#)).

## Annex 1 – Types of Mills

Category	Manual Mill	Diesel Mill	Electric Mill	Solar Mill
Details	Use of large mortar and pestle, rubbing stones, hand cranking manual grinder	Diesel by a diesel-powered engine that is coupled to the mill.	Driven by an AC induction motor that is coupled to the mill via a belt and typically operated on the grid or mini-grids.	
Availability	Common in low-income remote rural areas where people cannot afford paying for commercial grain-milling services <sup>14</sup>	Common in off grid areas	Common in peri urban, informal settlements with access to electricity	Relatively new in the market. Used for operations requiring low throughput
Power rating (kW)	<b>Human power</b>	<b>7.5-17.5</b>	<b>7.5-15</b>	<b>1.5-2.2<sup>15</sup></b>
Average Throughput (kg/hr) <sup>16</sup>	<b>&lt;5</b>	<b>120-150</b>	<b>120-150</b>	<b>32-60</b>

<sup>14</sup> <https://www.fao.org/3/j8482e/j8482e.pdf>

<sup>15</sup> This is a reflection of common solar mills in sub-Saharan Africa, the rating might be higher in other geographies

<sup>16</sup> [https://storage.googleapis.com/e4a-website-assets/EforA\\_Solar\\_Appliance\\_Technology\\_Brief\\_Milling\\_July-2021.pdf](https://storage.googleapis.com/e4a-website-assets/EforA_Solar_Appliance_Technology_Brief_Milling_July-2021.pdf)