

Y

Y-Series



Contents



The d&b System reality	4
The Y-Series	6
The Y7P and Yi7P loudspeakers	10
The Y10P and Yi10P loudspeakers	11
The B6 and Bi6 subwoofers	12
The Y7P, Y10P and B6 transport accessories	13
The Y8 and Yi8 loudspeakers	14
The Y12 and Yi12 loudspeakers	15
The Y and Yi subwoofers	16
The Y8, Y12 and Y-SUB transport accessories	17
The Y7P, Y10P and B6-SUB mounting accessories	18
The Y7P, Y10P and B6-SUB mounting examples	19
The Yi7P, Yi10P and Bi6-SUB mounting accessories	20
The Yi7P, Yi10P and Bi6-SUB mounting examples	21
The Y8/Yi8, Y12/Yi12 and Y/Yi-SUB rigging accessories	22
The Y8, Y12 and Y-SUB rigging examples	23
The Yi8, Yi12 and Yi-SUB rigging examples	24
The Yi Weather Resistant and Special Colour options	25
The d&b ArrayCalc simulation software	26
The d&b Remote network	27
The d&b amplifiers	28
The operation with d&b amplifiers	30
The Y-Series frequency responses	31
The d&b amplifier output modes	32
The Y-Series cables and adapters	34
The Y-Series configuration examples	36
The Y-Series product overview	42



d&b System reality

As the name implies a d&b audiotechnik system is not just a loudspeaker. Nor is it merely a sum of the components: loudspeakers, amplifiers, accessories and software. Right from the outset the d&b audiotechnik approach was to build integrated sound reinforcement systems that actually are more

than the combination of parts: an entirety where each fits all. Every element is tightly specified, precisely aligned and carefully integrated to achieve maximum efficiency. For ease of use, all the user-definable parameters are integrated, allowing the possibility of adjustment, either via remote control surfaces or directly on the

amplifiers. Neutral sound characteristics leave the user all the freedom needed to realise whatever the brief. At the same time d&b offers integrated finance, service and support, a knowledgeable distribution network, education and training as well as technical information, so the same optimal acoustic result

is achieved consistently by every system anywhere, at any time. In reality: the d&b System reality.

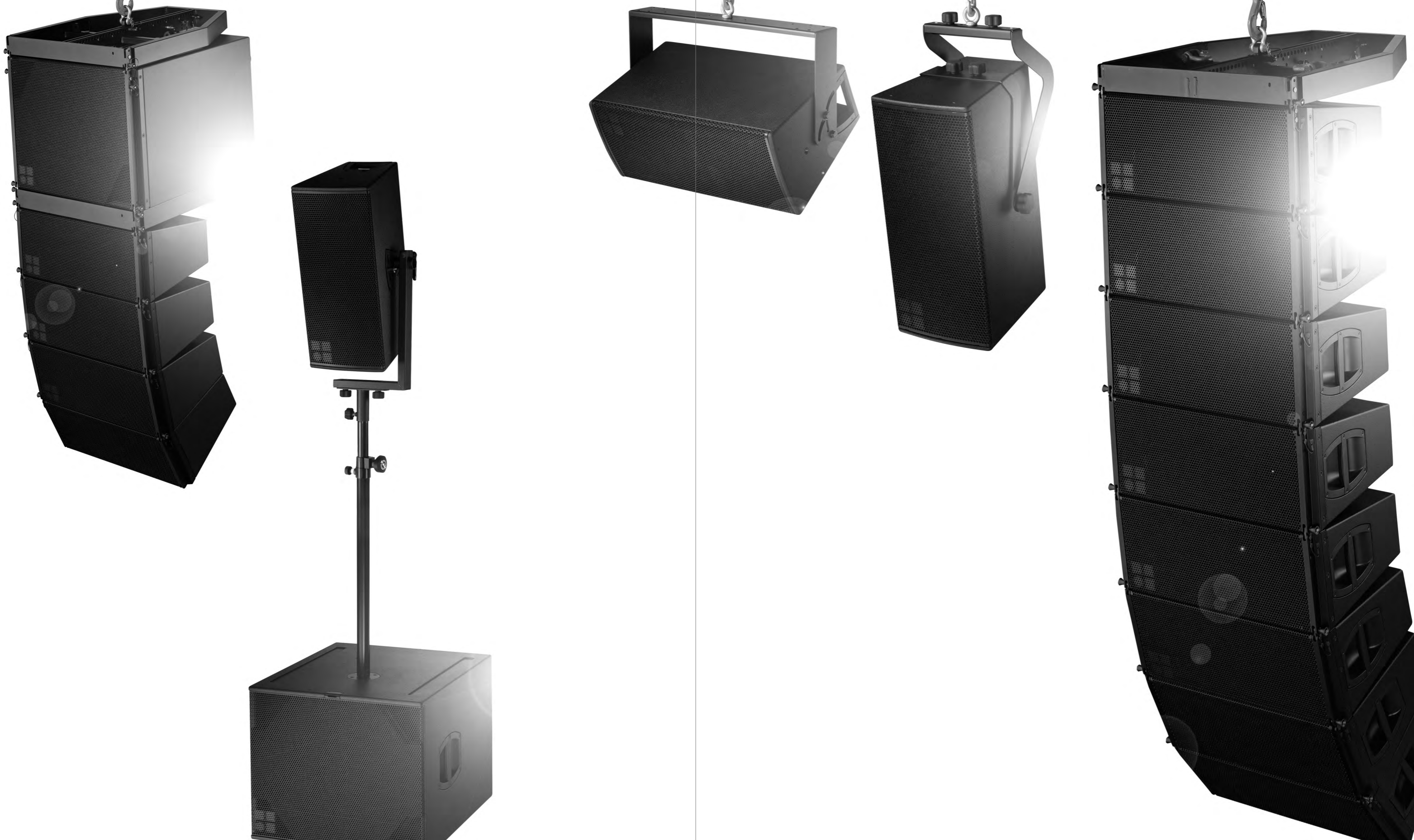

The **Y-Series** loudspeakers are designed with a clear perspective to provide flexible and configurable solutions, even in the most arduous sound reinforcement situations. Performing arts, conferences, religious events and live shows; applications all demanding strict qualities in the performance, look and feel of a loudspeaker. On one side the Y-Series provides adept small to

medium scale, stand alone or distributed point source solutions, whereas on the other hand the wide spectrum of mid-sized line array potential is inherited from its bigger brothers, the V-Series and J-Series. Flexible horizontal dispersion characteristics combined with either rotatable horns or innovative custom waveguides ensure constant directivity over a wide bandwidth.

Dipolar driver arrangements deliver accurate dispersion control, while a deep LF performance is derived from the bass-reflex design. Three point rigging systems are integrated into the arrayable cabinets, even the cardioid subwoofer, these, together with ground stacking options, present an abundance of opportunity for deployment. The **Yi loudspeakers** differ only

slightly in cabinet construction, finish and mounting hardware. They are intended for permanently installed performance spaces where the specification is rider driven by the artist or mix engineer's preferences. Both the Yi cabinets and mounting hardware can be properly colour matched to interior designs and weather protected for climatically hostile environments.

The Y-Series

The **Y7P** and **Yi7P** as well as the **Y10P** and **Yi10P** point source loudspeakers both feature the same dipolar arrangement with two 8" drivers centered around a 1.4" HF compression driver mounted on a CD horn with 75° x 40° and 110° x 40° dispersion characteristics respectively. A rotatable horn enables deployment in either orientation, whilst an innovative bass-reflex and port design gives an increased LF performance. The high performance omnidirectional **B6** and **Bi6-SUB** feature a single 18" long excursion driver, intended for ground stacked applications only.



Y7P, Y10P loudspeaker



Yi7P, Yi10P loudspeaker



B6 subwoofer



Bi6 subwoofer



Y8, Y12 loudspeaker



Yi8, Yi12 loudspeaker



Y subwoofer



Yi subwoofer

The **Y8** and **Y12** and the installation specific **Yi8** and **Yi12** line array modules also share the same driver arrangement, with two 8" dipolar mounted drivers and a 1.4" HF driver combined with a central wave transformer. The advanced bass-reflex and port arrangement delivers full bandwidth capabilities with an extended LF output. Due to the dipolar arrangement of the LF drivers, a broadband, horizontal directivity control is maintained down to approximately 500 Hz for the different dispersion options, 80° for the Y8 and 120° for the Y12. The arrayable, cardioid **Y** and **Yi-SUB** both house two long excursion neodymium drivers, powered by a single amplifier channel. The 18" and 12" drivers arranged in an integrated cardioid setup, avoid unwanted energy behind the system.

All Y loudspeakers are finished with a PCP (Polyurea Cabinet Protection) coating that provides mobile systems with protection against impact and resistance to the adverse effects on cabinets caused by changing ambient outdoor conditions. The Yi cabinets feature an impact resistant paint finish; Weather Resistant and Special Colour options are available.

The d&b software offering aids the entire system setup process, from the simulation and planning of the loudspeaker systems, to the remote control and monitoring of the system functions during the event, followed by service functionality to verify system performance prior to de-rigging. The **ArrayCalc** simulation software allows the virtual optimization of loudspeaker line arrays, point source and column loudspeakers as well as subwoofers and their adjustment to venue conditions. The complete system configuration simulated in ArrayCalc is assimilated by the **R1 Remote control software** into an intuitive graphical user interface to manage the amplifiers, and loudspeakers, from anywhere in the venue. Service functions enable firmware updates of the amplifiers as and when these are available.

d&b amplifiers are specifically designed for use with d&b loudspeakers, and are at the heart of the d&b system approach. These devices contain extensive Digital Signal Processing capabilities to provide comprehensive loudspeaker management and specific switchable filter functions to precisely target the system response for a wide variety of applications. The four channel **D80** amplifier is intended for both mobile and installation applications requiring the highest Sound Pressure Levels. The installation specific four channel **30D** amplifier is intended for permanent integration within venues which require medium to high Sound Pressure Levels. These amplifiers all provide extensive user-definable equalization containing two 16-band equalizers with parametric, notch, shelving and asymmetric filters as well as delay capabilities of up to 10 seconds.

An extensive range of standardized transport solutions is offered for the Y-Series, consisting of touring cases, touring carts as well as transport lids. Complete cabling structures including multicores and breakouts are also available, alongside extensive mounting options. A D80 touring rack assembly can be provided, which offers a fully equipped and prewired system rack, providing mains power distribution, connector interfaces and all internal cabling for three D80 amplifiers.



D80 amplifier



30D amplifier

The Y7P and Yi7P loudspeakers

Y7P and Yi7P loudspeakers

The compact, 2-way passive Y7P and Yi7P loudspeakers feature two 8" drivers in a dipole arrangement with a 1.4" compression driver mounted onto a rotatable CD horn. The Yi7P is the installation version of the Y7P loudspeaker and differs only in cabinet construction, finish and mounting hardware. Sophisticated horn geometry combined with the advanced bass-reflex port design delivers full bandwidth capabilities with an extended LF output. These point source, high performance cabinets offer 75° horizontal directivity matched with a vertical dispersion of 40°; the horn can be rotated by 90° to enable horizontal orientation. The Y7P/Yi7P provide a broad variety of deployment possibilities, especially when used as a stand-alone full range system, or combined with other elements from the Y-Series, either ground stacked or flown.

The loudspeaker cabinets are constructed from marine plywood, the Y7P has an impact and weather protected PCP (Polyurea Cabinet Protection) finish, while the Yi7P has an impact resistant paint finish. The front of the loudspeaker cabinets are protected by a rigid metal grill. The Y7P cabinet incorporates a pair of handles whilst M10 threaded inserts are provided for attaching d&b rigging hardware.

System data

Frequency response (-5 dB standard) 59 Hz - 18 kHz
 Frequency response (-5 dB CUT mode) 118 Hz - 18 kHz
 Max. sound pressure (1 m, free field)¹
 with D6/10D 132 dB
 with D12/30D/D20 135 dB
 with D80 137 dB
 Input level (100 dB SPL/1 m) -17 dBu

Loudspeaker data

Nominal impedance 8 ohms
 Power handling capacity (RMS/peak 10 ms) 400/1600 W
 Nominal dispersion angle (h x v) 75° x 40°
 Components 2 x 8" driver with neodymium magnet
 1.4" exit compression driver
 passive crossover network
 Connections Y7P 2 x NLT4 F/M
 optional 2 x NL4 or 2 x EP5
 Connections Yi7P 2 x NL4 and screw terminal block
 Weight Y7P / Yi7P 18 kg (40 lb)

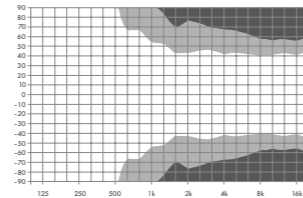

Y7P and Yi7P horizontal dispersion characteristics²

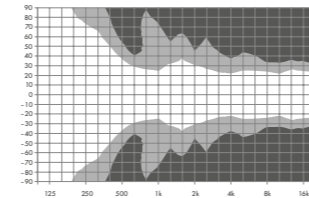

Y7P and Yi7P vertical dispersion characteristics²

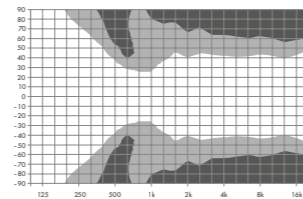

Y7P and Yi7P horizontal dispersion characteristics/horizontal setup, horn rotated²

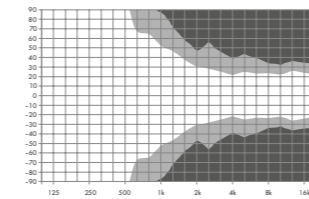

Y7P and Yi7P vertical dispersion characteristics/horizontal setup, horn rotated²

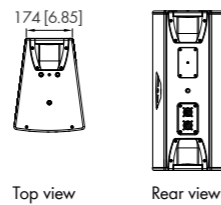
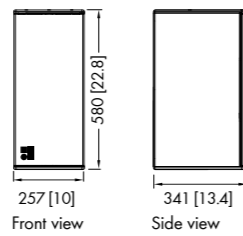

Y7P cabinet dimensions in mm [inch]

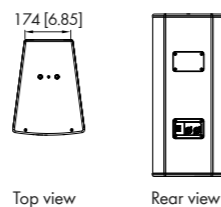
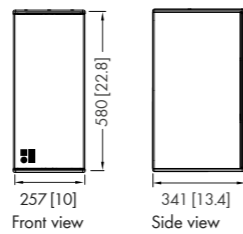

Yi7P cabinet dimensions in mm [inch]

¹ Broadband measurement, pink noise, crest factor 4, peak measurement, linear weighting
² Dispersion angle vs frequency plotted using lines of equal sound pressure (isobars) at -6 dB and -12 dB

The Y10P and Yi10P loudspeakers

Y10P and Yi10P loudspeakers

The compact, 2-way passive Y10P and Yi10P loudspeakers feature two 8" drivers in a dipole arrangement with a 1.4" compression driver mounted onto a rotatable CD horn. The Yi10P is the installation version of the Y10P loudspeaker and differs only in cabinet construction, finish and mounting hardware. Sophisticated horn geometry combined with the advanced bass-reflex port design delivers full bandwidth capabilities with an extended LF output. These point source, high performance cabinets offer 110° horizontal directivity matched with a vertical dispersion of 40°; the horn can be rotated by 90° to enable horizontal orientation.

The Y10P/Yi10P provide a broad variety of deployment possibilities, especially when used as a stand-alone full range system, or combined with other elements from the Y-Series, either ground stacked or flown.

The loudspeaker cabinets are constructed from marine plywood, the Y10P has an impact and weather protected PCP (Polyurea Cabinet Protection) finish, while the Yi10P has an impact resistant paint finish. The front of the loudspeaker cabinets are protected by a rigid metal grill. The Y10P cabinet incorporates a pair of handles whilst M10 threaded inserts are provided for attaching d&b rigging hardware.

System data

Frequency response (-5 dB standard) 59 Hz - 18 kHz
 Frequency response (-5 dB CUT mode) 118 Hz - 18 kHz
 Max. sound pressure (1 m, free field)¹
 with D6/10D 131 dB
 with D12/30D/D20 134 dB
 with D80 136 dB
 Input level (100 dB SPL/1 m) -17 dBu

Loudspeaker data

Nominal impedance 8 ohms
 Power handling capacity (RMS/peak 10 ms) 400/1600 W
 Nominal dispersion angle (h x v) 110° x 40°
 Components 2 x 8" driver with neodymium magnet
 1.4" exit compression driver
 passive crossover network
 Connections Y10P 2 x NLT4 F/M
 optional 2 x NL4 or 2 x EP5
 Connections Yi10P 2 x NL4 and screw terminal block
 Weight Y10P / Yi10P 18 kg (40 lb)

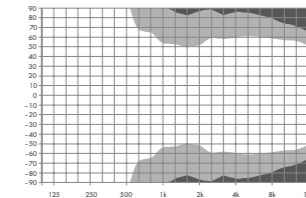

Y10P and Yi10P horizontal dispersion characteristics²

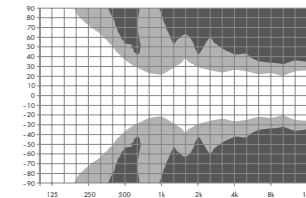

Y10P and Yi10P vertical dispersion characteristics²

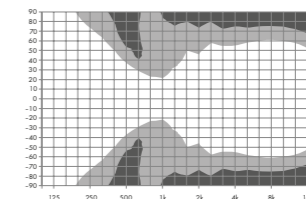

Y10P and Yi10P horizontal dispersion characteristics/horizontal setup, horn rotated²

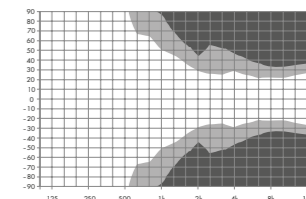

Y10P and Yi10P vertical dispersion characteristics/horizontal setup, horn rotated²

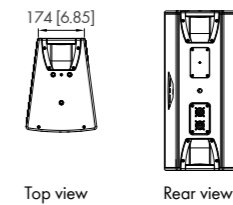
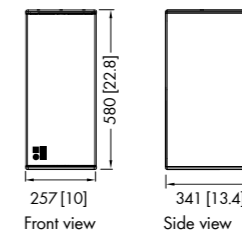

Y10P cabinet dimensions in mm [inch]

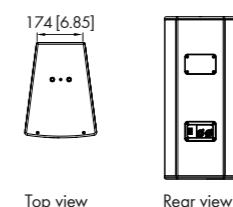
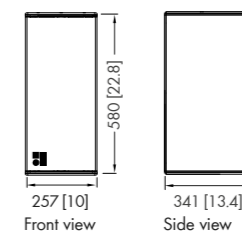

Yi10P cabinet dimensions in mm [inch]

¹ Broadband measurement, pink noise, crest factor 4, peak measurement, linear weighting
² Dispersion angle vs frequency plotted using lines of equal sound pressure (isobars) at -6 dB and -12 dB

The B6 and Bi6 subwoofers

B6 and Bi6 subwoofers

The B6-SUB and Bi6-SUB are high performance subwoofers designed for ground stacked applications, housing a long excursion 18" driver built into a bass-reflex design. The Bi6-SUB is the installation version of the B6 subwoofer and differs only in cabinet construction, finish and mounting hardware.

When three or any multiple of three B6 or Bi6 subwoofers are used, they can be positioned in a Cardioid Subwoofer Array, achieving exceptional directivity control in lower frequencies and significantly reducing the energy radiating towards to the rear. The cabinets are constructed from marine plywood, the B6-SUB has an impact and weather protected PCP (Polyurea Cabinet Protection) finish, while the Bi6-SUB has an impact resistant paint finish. The front of the loudspeaker cabinet is protected by a rigid metal grill backed by an acoustically transparent foam. The side panels of the B6-SUB incorporate two handles, whilst four wheels are mounted to the rear and the enclosure features two runners to protect the bottom panel from scratching. Two correspondingly shaped recesses are incorporated into the top panel of each B6-SUB cabinet to accept these runners, preventing cabinet movement when stacked. An M20 threaded flange in the top panel accepts the d&b Loudspeaker stand winder M20.

System data

Frequency response (-5 dB standard) 37 Hz - 140 Hz
 Frequency response (-5 dB 100 Hz mode) 37 Hz - 110 Hz
 Max. sound pressure (1 m, free field)¹
 with D6/10D 128 dB
 with D12/30D/D20 131 dB
 with D80 134 dB

Loudspeaker data

Nominal impedance 8 ohms
 Power handling capacity (RMS/peak 10 msec) 500/2000 W
 Components 1 x 18" driver
 Connections B6 2 x NLT4 F/M
 optional 2 x NL4 or 2 x EP5
 Connections Bi6 2 x NL4 and screw terminal block
 Weight B6/Bi6 41/38 kg (90/84 lb)

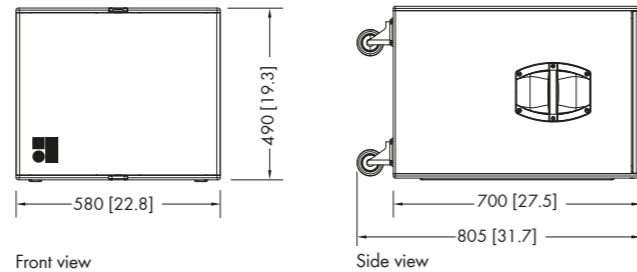

Front view

Side view

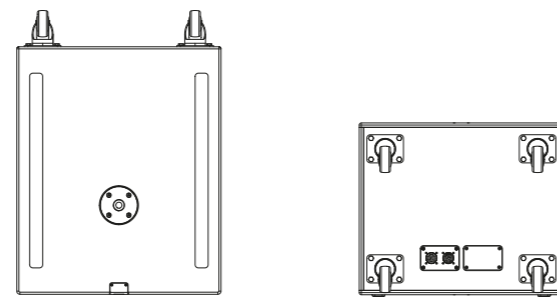

Top view

Rear view

B6-SUB cabinet dimensions in mm [inch]

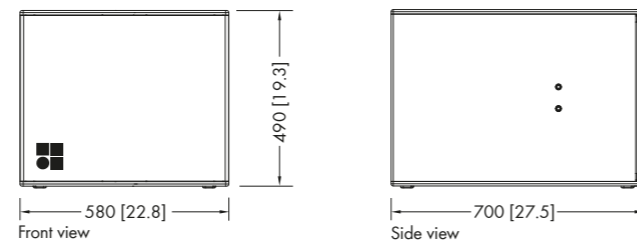

Front view

Side view

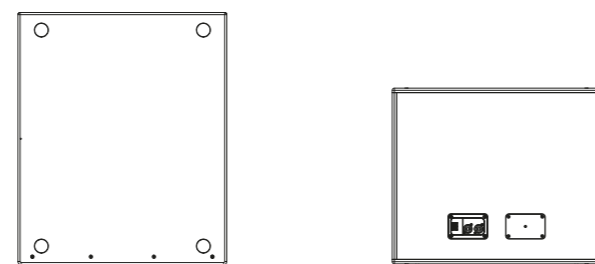

Top view

Rear view

Bi6-SUB cabinet dimensions in mm [inch]

The Y7P, Y10P and B6 transport accessories

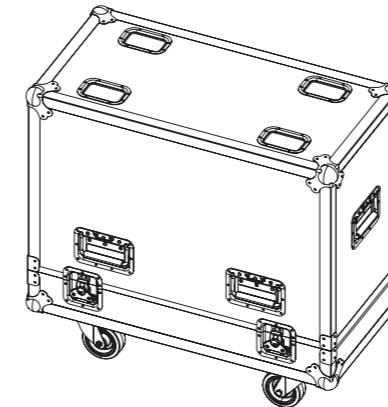

E7473
Touring case 2 x Y7P/Y10P

Dimensions (H x W x D):
 775 x 812 x 417 mm
 30.5 x 32 x 16.4 inch
 Net weight: 38 kg (84 lb)

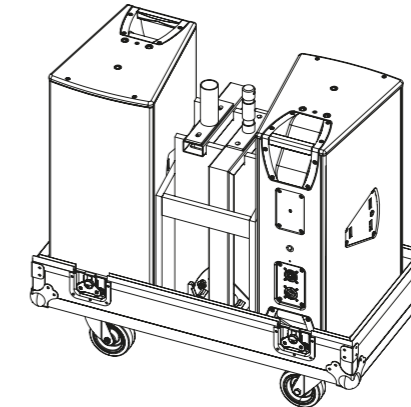

E7925
B6-SUB Transport lid

The Y8 and Yi8 loudspeakers

Y8 and Yi8 loudspeakers

The compact Y8 and Yi8 line array loudspeakers are designed for use in vertical columns. The 2-way passive design features two 8" drivers in a dipole arrangement and a centrally mounted 1.4" compression driver with a wave transformer. The Yi8 is the installation version of the Y8 loudspeaker and differs only in cabinet construction, finish and mounting hardware.

Sophisticated horn geometry combined with the advanced bass-reflex port design delivers full bandwidth capabilities with an extended LF output. These high performance line array modules offer 80° horizontal directivity controlled down to 500 Hz.

The mechanical and acoustical design enables vertical arrays of up to twenty four loudspeakers with vertical splay angles from 0° to 14° with a 1° resolution. It can be used in columns of purely Y8 or Yi8 loudspeakers or combined with Y12/Yi12 and/or Y-SUB/Yi-SUB cabinets.

The loudspeaker cabinets are constructed from marine plywood, the Y8 has an impact and weather protected PCP (Polyurea Cabinet Protection) finish, while the Yi8 has an impact resistant paint finish. The front of the loudspeaker cabinet is protected by a rigid metal grill backed by an acoustically transparent foam.

Each side panel of the Y8 incorporates a handle while two additional recessed grips are provided at the rear. Three point rigging hardware is integrated into the loudspeaker enclosure.

System data

Frequency response (-5 dB standard)	54 Hz - 19 kHz
Frequency response (-5 dB CUT mode)	100 Hz - 19 kHz
Max. sound pressure (1 m, free field) ¹	
with D6/10D	134 dB
with D12/30D/D20	137 dB
with D80	139 dB

Loudspeaker data

Nominal impedance	8 ohms
Power handling capacity (RMS/peak 10 ms)	400/1600 W
Nominal dispersion angle (h)	80°
Splay angle settings	0° - 14° (1° increment)
Components	2 x 8" driver with neodymium magnet 1.4" exit compression driver passive crossover network
Connections Y8	2 x NLT4 F/M
Connections Yi8	optional 2 x NL4 or 2 x EP5
Weight Y8/Yi8	20 kg (44 lb)

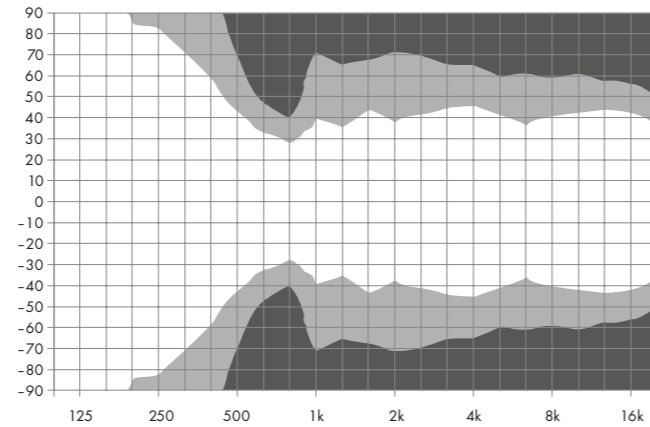

Y8 and Yi8 horizontal dispersion characteristics²

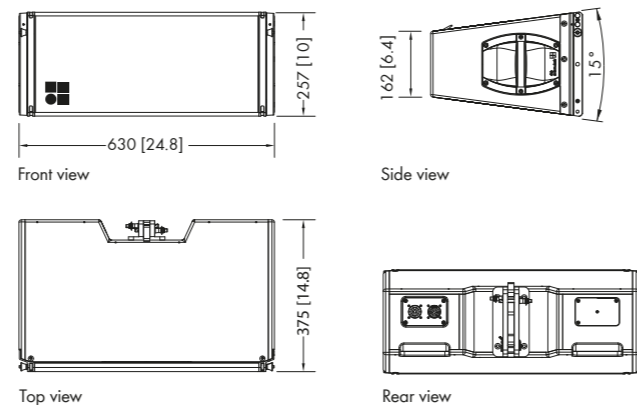

Y8 cabinet dimensions in mm (inch)

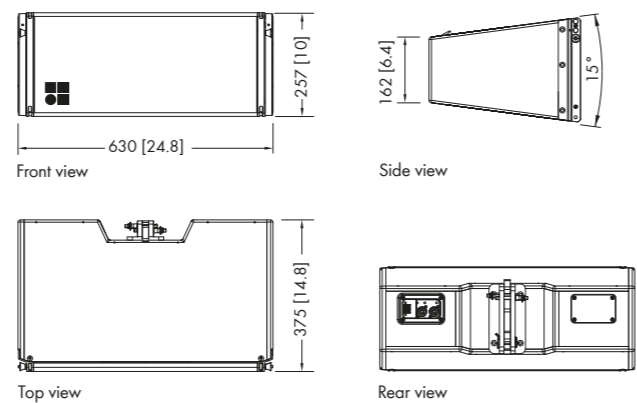

Yi8 cabinet dimensions in mm (inch)

¹ Broadband measurement, pink noise, crest factor 4, peak measurement, linear weighting
² Dispersion angle vs frequency plotted using lines of equal sound pressure (isobars) at -6 dB and -12 dB

The Y12 and Yi12 loudspeakers

Y12 and Yi12 loudspeakers

The compact Y12 and Yi12 line array loudspeakers are designed for use in vertical columns. The 2-way passive design features two 8" drivers in a dipole arrangement and a centrally mounted 1.4" compression driver with a wave transformer. The Yi12 is the installation version of the Y12 loudspeaker and differs only in cabinet construction, finish and mounting hardware.

Sophisticated horn geometry combined with the advanced bass-reflex port design delivers full bandwidth capabilities with an extended LF output. These high performance line array modules offer 120° horizontal directivity controlled down to 500 Hz.

The mechanical and acoustical design enables vertical arrays of up to twenty four loudspeakers with vertical splay angles from 0° to 14° with a 1° resolution. It can be used in columns of purely Y12 or Yi12 loudspeakers or combined with Y8/Yi8 and/or Y-SUB/Yi-SUB cabinets.

The loudspeaker cabinets are constructed from marine plywood, the Y12 has an impact and weather protected PCP (Polyurea Cabinet Protection) finish, while the Yi12 has an impact resistant paint finish. The front of the loudspeaker cabinet is protected by a rigid metal grill backed by an acoustically transparent foam.

Each side panel of the Y12 incorporates a handle while two additional recessed grips are provided at the rear. Three point rigging hardware is integrated into the loudspeaker enclosure.

System data

Frequency response (-5 dB standard)	54 Hz - 19 kHz
Frequency response (-5 dB CUT mode)	100 Hz - 19 kHz
Max. sound pressure (1 m, free field) ¹	
with D6/10D	134 dB
with D12/30D/D20	137 dB
with D80	139 dB

Loudspeaker data

Nominal impedance	8 ohms
Power handling capacity (RMS/peak 10 ms)	400/1600 W
Nominal dispersion angle (h)	120°
Splay angle settings	0° - 14° (1° increment)
Components	2 x 8" driver with neodymium magnet 1.4" exit compression driver passive crossover network
Connections Y12	2 x NLT4 F/M
Connections Yi12	optional 2 x NL4 or 2 x EP5
Weight Y12/Yi12	20 kg (44 lb)

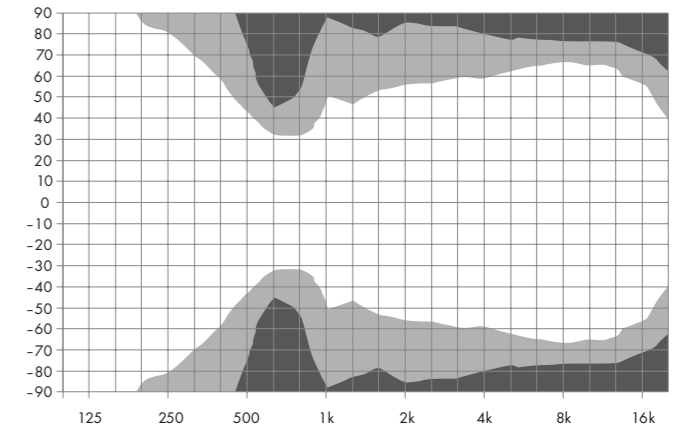

Y12 and Yi12 horizontal dispersion characteristics²

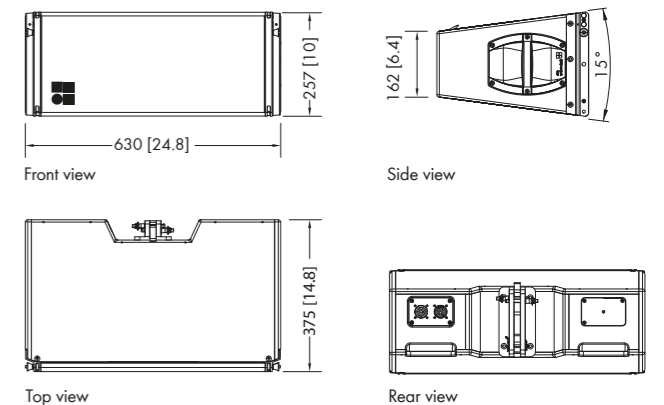

Y12 cabinet dimensions in mm (inch)

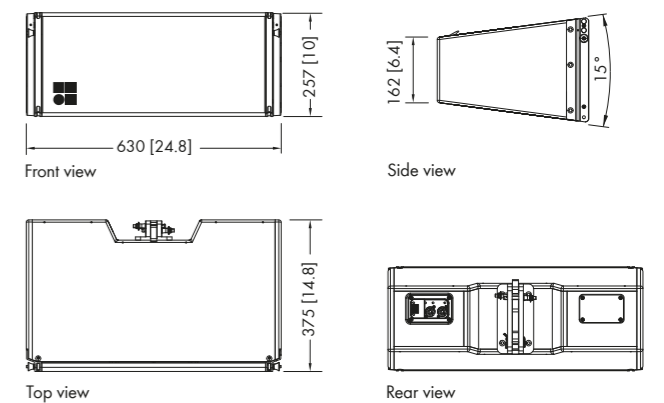

Yi12 cabinet dimensions in mm (inch)

¹ Broadband measurement, pink noise, crest factor 4, peak measurement, linear weighting
² Dispersion angle vs frequency plotted using lines of equal sound pressure (isobars) at -6 dB and -12 dB

The Y and Yi subwoofers

Y and Yi subwoofers

The Y-SUB and Yi-SUB are actively driven cardioid subwoofers powered by a single amplifier channel. The Yi-SUB is the installation version of the Y-SUB and differs only in cabinet construction, finish and mounting hardware. They house two long excursion neodymium drivers in an integrated cardioid setup, an 18" driver in a bass-reflex chamber facing to the front and a 12" driver in a two chamber bandpass design radiating towards the rear.

The cardioid dispersion pattern resulting from this arrangement avoids the distribution of energy behind the system, providing the greatest accuracy of low frequency reproduction and reducing the energy dispersed into unwanted areas. The Y-SUB and Yi-SUB are fitted with three point rigging hardware and can be flown in columns of purely Y or Yi subwoofers, at the top of a Y/Yi array or used in a ground stacked setup.

The cabinets are constructed from marine plywood; the Y-SUB has an impact and weather protected PCP (Polyurea Cabinet Protection) finish while the Yi-SUB has an impact resistant paint finish. The front of the loudspeaker cabinet is protected by a rigid metal grill backed by an acoustically transparent foam, whilst the side panels of the Y-SUB incorporate four handles with four wheels mounted to the rear.

System data

Frequency response (-5 dB standard).....	39 Hz - 140 Hz
Frequency response (-5 dB 100 Hz mode).....	39 Hz - 110 Hz
Max. sound pressure (1 m, free field) ¹	
with D6/10D	128 dB
with D12/30D/D20	131 dB
with D80	134 dB

Loudspeaker data

Nominal impedance.....	8 ohms
Power handling capacity (RMS/peak 10 ms)	600/2400 W
Splay angle settings	0° and 2.5°
Components.....	1x 18" driver with neodymium magnet
.....	1x 12" driver with neodymium magnet
Connections Y-SUB.....	2 x NLT4 F/M
.....	optional 2 x NL4 or 2 x EP5
Connections Yi-SUB	2 x NL4 and screw terminal block
Weight Y-SUB/Yi-SUB	52/49 kg (115/108 lb)

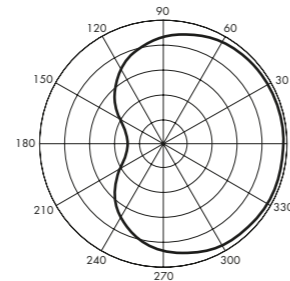

Cardioid polar pattern

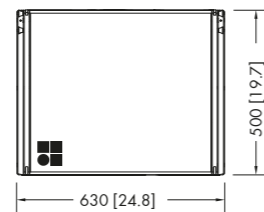

Front view

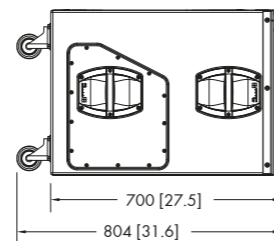

Side view

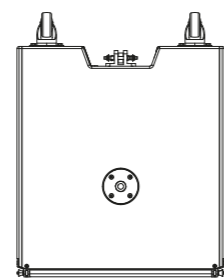

Top view

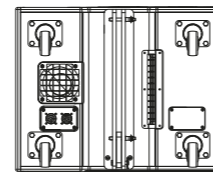

Rear view

Y-SUB cabinet dimensions in mm [inch]

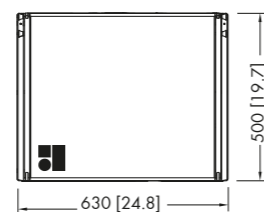

Front view

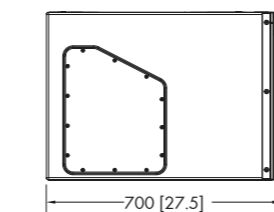

Side view

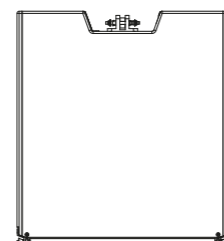

Top view

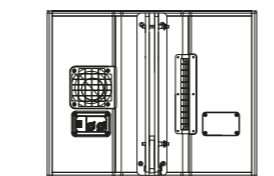

Rear view

Yi-SUB cabinet dimensions in mm [inch]

The Y8, Y12 and Y-SUB transport accessories

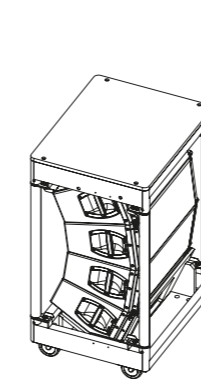

E7470

Touring cart 4 x Y8/Y12

Dimensions (H x W x D):
1200 x 600 x 730 mm
47.3 x 23.7 x 29 inch
Total weight: 130 kg (285 lb)
Max. top load: 100 kg (220 lb)

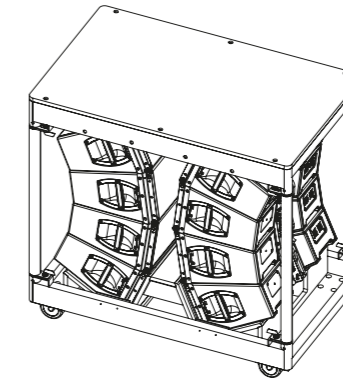

E7471

Touring cart 8 x Y8/Y12

Dimensions (H x W x D):
1200 x 1200 x 730 mm
47.3 x 47.3 x 29 inch
Total weight: 230 kg (510 lb)
Max. top load: 200 kg (440 lb)

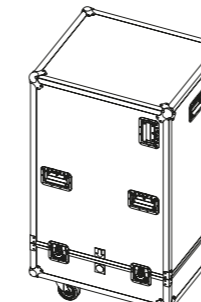

E7472

Touring case 4 x Y8/Y12

Dimensions (H x W x D):
1271 x 724 x 626 mm
50 x 28.5 x 24.6 inch
Net weight: 61 kg (135 lb)

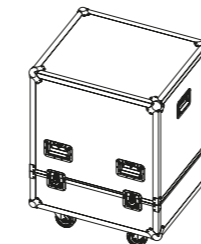
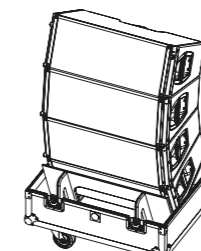

E7475

Touring case 2 x Y Flying frame

Dimensions (H x W x D):
962 x 724 x 628 mm
38 x 28.5 x 24.7 inch
Net weight: 51 kg (112 lb)

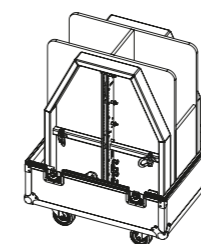

E7924

Y-SUB Transport lid

The Y7P, Y10P and B6-SUB mounting accessories

Safety approval

d&b loudspeakers and accessories are designed for setup and use within situations requiring compliance with the provisions and directives of the DGUV regulation 17 (formerly BGV C1).

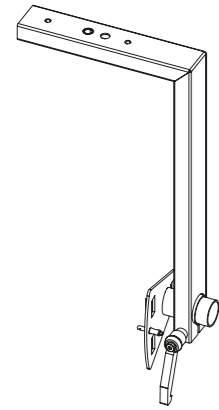

Z5397
YP Swivel bracket

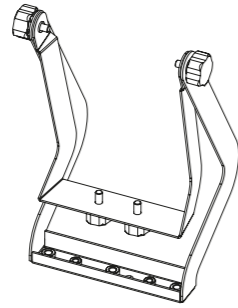

Z5399
YP Mounting bracket

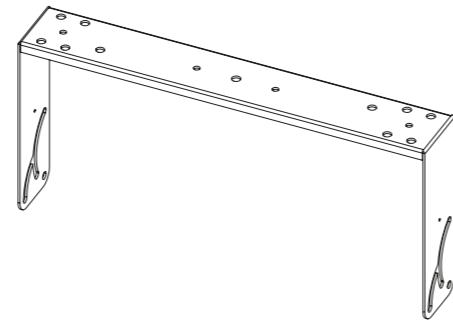

Z5398
YP Horizontal bracket

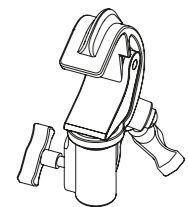

Z5012
Pipe clamp

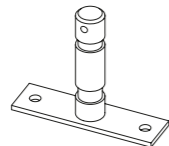

Z5010
TV spigot with fixing plate

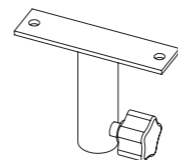

Z5024
Loudspeaker stand adapter

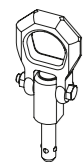

Z5049
Flying pin 8mm

The Y7P, Y10P and B6-SUB mounting examples

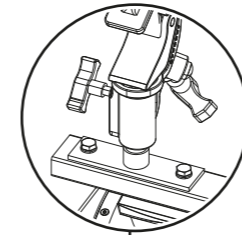

Y7P/Y10P with
Z5397 YP Swivel bracket
Z5010 TV spigot with fixing plate
Z5012 Pipe clamp

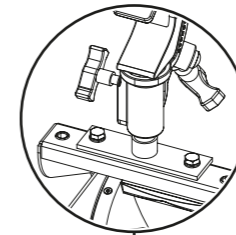

Y7P/Y10P with
Z5399 YP Mounting bracket
Z5010 TV spigot with fixing plate
Z5012 Pipe clamp

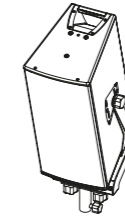

Y7P/Y10P with
Z5399 YP Mounting bracket
Z5024 Loudspeaker stand adapter

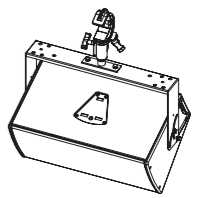

Y7P/Y10P with
Z5398 YP Horizontal bracket
Z5010 TV spigot with fixing plate
Z5012 Pipe clamp

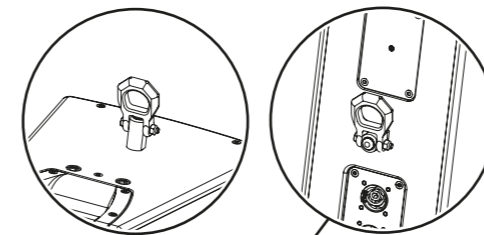

Y7P/Y10P with
2 x Z5049 Flying pin 8mm

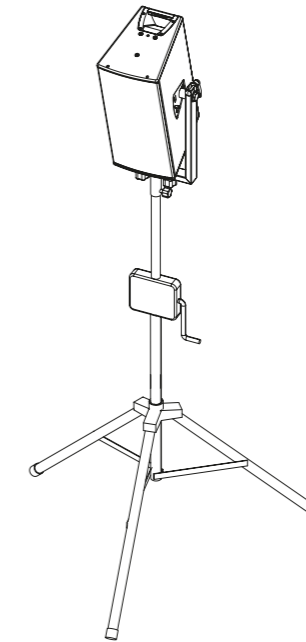

Y7P/Y10P with
Z5397 YP Swivel bracket
Z5009 Loudspeaker stand with winder
Z5024 Loudspeaker stand adapter

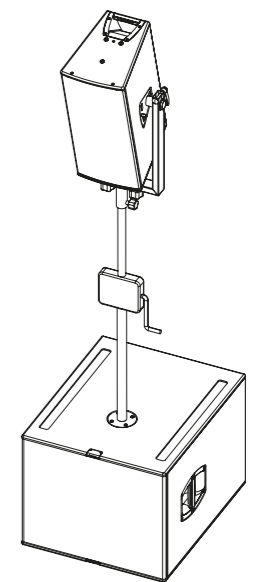

Y7P/Y10P with
Z5397 YP Swivel bracket
Z5013 Loudspeaker stand winder M20
Z5024 Loudspeaker stand adapter

The Yi7P, Yi10P and Bi6-SUB mounting accessories

The Yi7P, Yi10P and Bi6-SUB mounting examples

Safety approval

d&b loudspeakers and accessories are designed for setup and use within situations requiring compliance with the provisions and directives of the DGUV regulation 17 (formerly BGV C1).

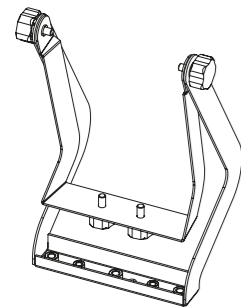

Z5399
YP Mounting bracket

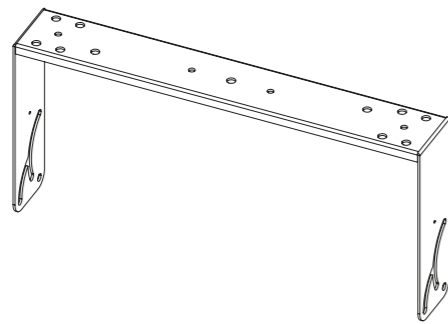

Z5398
YP Horizontal bracket

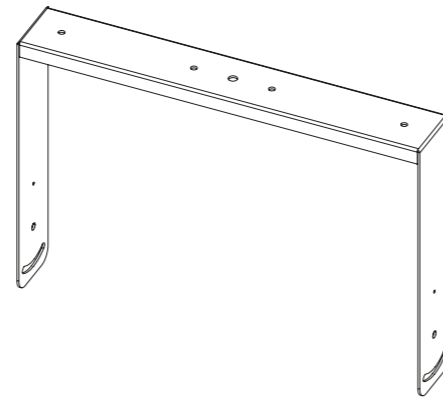

Z5389
Bi6-SUB Horizontal bracket

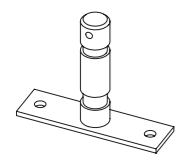

Z5010
TV spigot with fixing plate

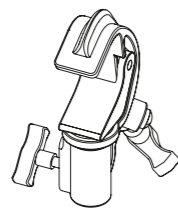

Z5012
Pipe clamp

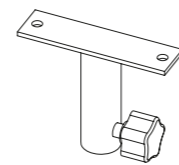

Z5024
Loudspeaker stand adapter

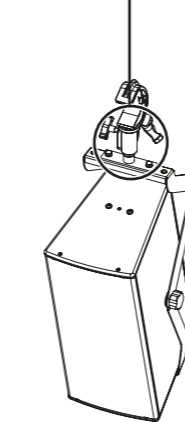
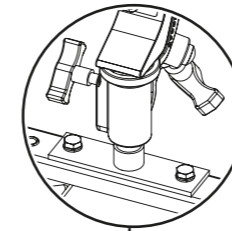

Yi7P/Yi10P with
Z5399 YP Mounting bracket
Z5010 TV spigot with fixing plate
Z5012 Pipe clamp

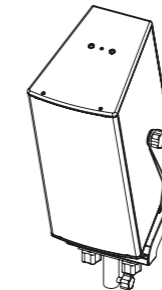

Yi7P/Yi10P with
Z5399 YP Mounting bracket
Z5024 Loudspeaker stand adapter

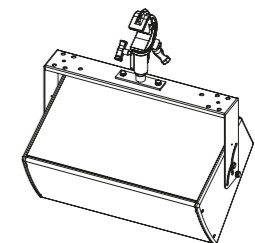

Yi7P/Yi10P with
Z5398 YP Horizontal bracket
Z5010 TV spigot with fixing plate
Z5012 Pipe clamp

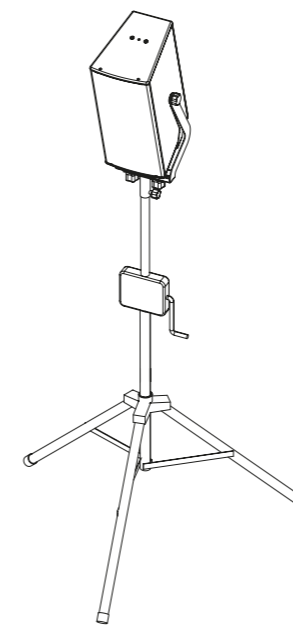

Yi7P/Yi10P with
Z5399 YP Mounting bracket
Z5009 Loudspeaker stand with winder

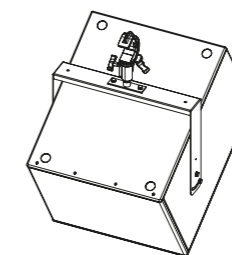

Bi6-SUB with
Z5389 Bi6 Horizontal bracket
Z5010 TV spigot with fixing plate
Z5012 Pipe clamp

The Y8/Yi8, Y12/Yi12 and Y/Yi-SUB rigging accessories

Safety approval

d&b loudspeakers and accessories are designed for setup and use within situations requiring compliance with the provisions and directives of the DGUV regulation 17 (formerly BGV C1).

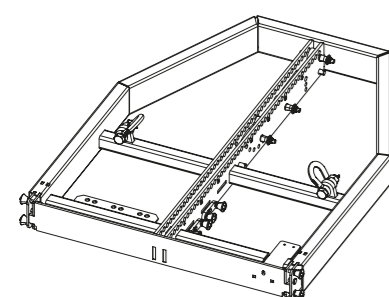

Z5390
Y Flying frame
For a maximum of twenty four Y8/Y12/Yi8/Yi12 loudspeakers or ten Y/Yi subwoofers

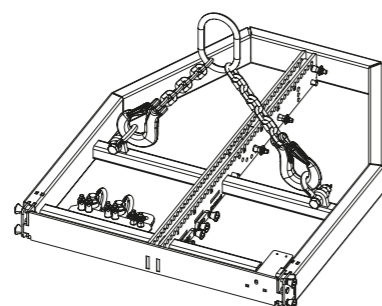

Z5390
Y Flying frame
Supplied with
1 x Z5392 Y Safety chainset
2 x Y Load adapter
1 x Y Load adapter for Rota clamp
2 x Front links

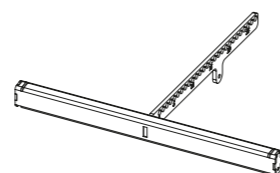

Z5394
Y Flying adapter
For a maximum of six Y8/Y12 loudspeakers; supplied with 1t Shackle

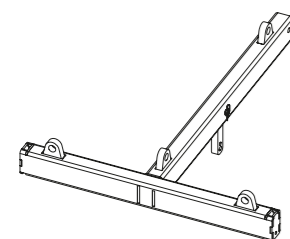

Z5393.000
Y Mounting frame top
For a maximum load equivalent to six Yi8/Yi12 loudspeakers

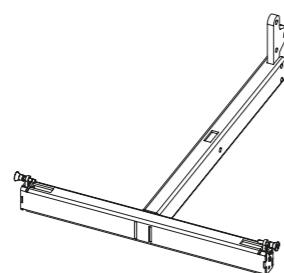

Z5393.001
Y Mounting frame bottom

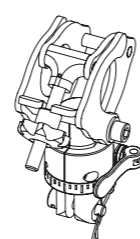

Z5147
Rota clamp



Z5392
Y Safety chain set



Z5391
Y Hoist connector chain



E6507
1t Shackle

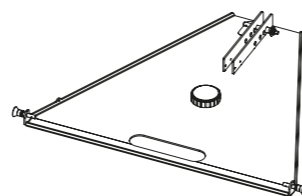

Z5396
Y Base plate

The Y8, Y12 and Y-SUB rigging examples

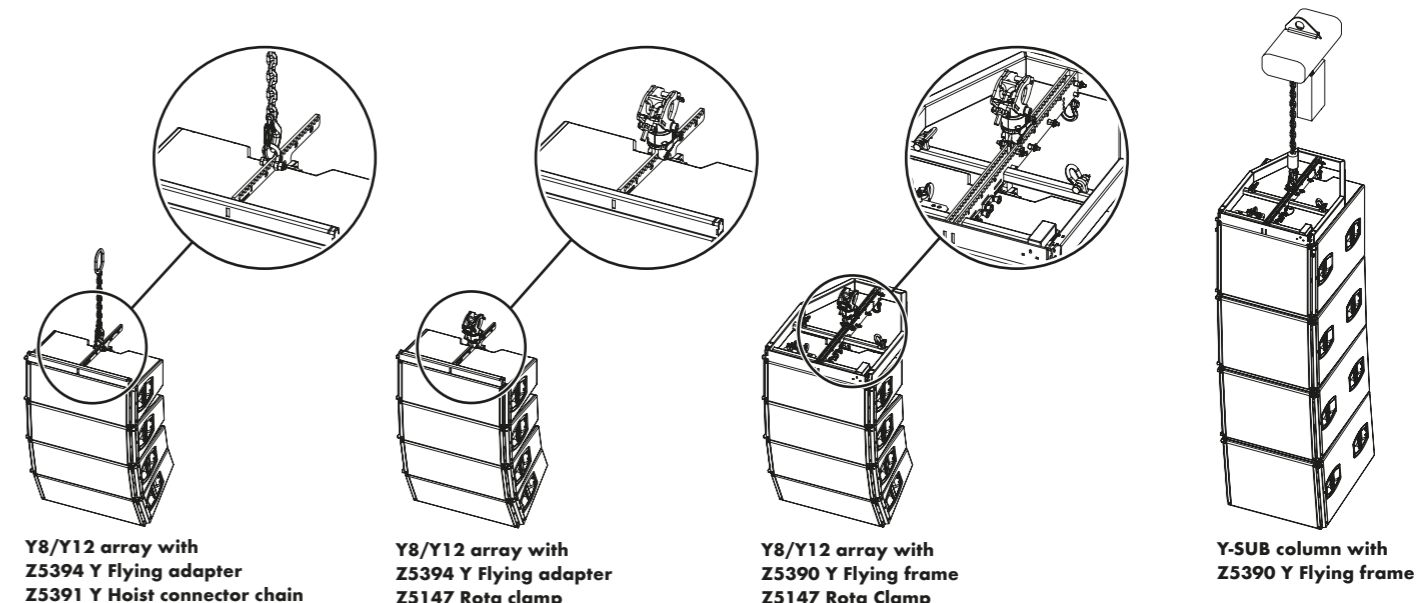

Y8/Y12 array with Z5394 Y Flying adapter Z5391 Y Hoist connector chain

Y8/Y12 array with Z5394 Y Flying adapter Z5147 Rota clamp

Y8/Y12 array with Z5390 Y Flying frame Z5147 Rota Clamp

Y-SUB column with Z5390 Y Flying frame

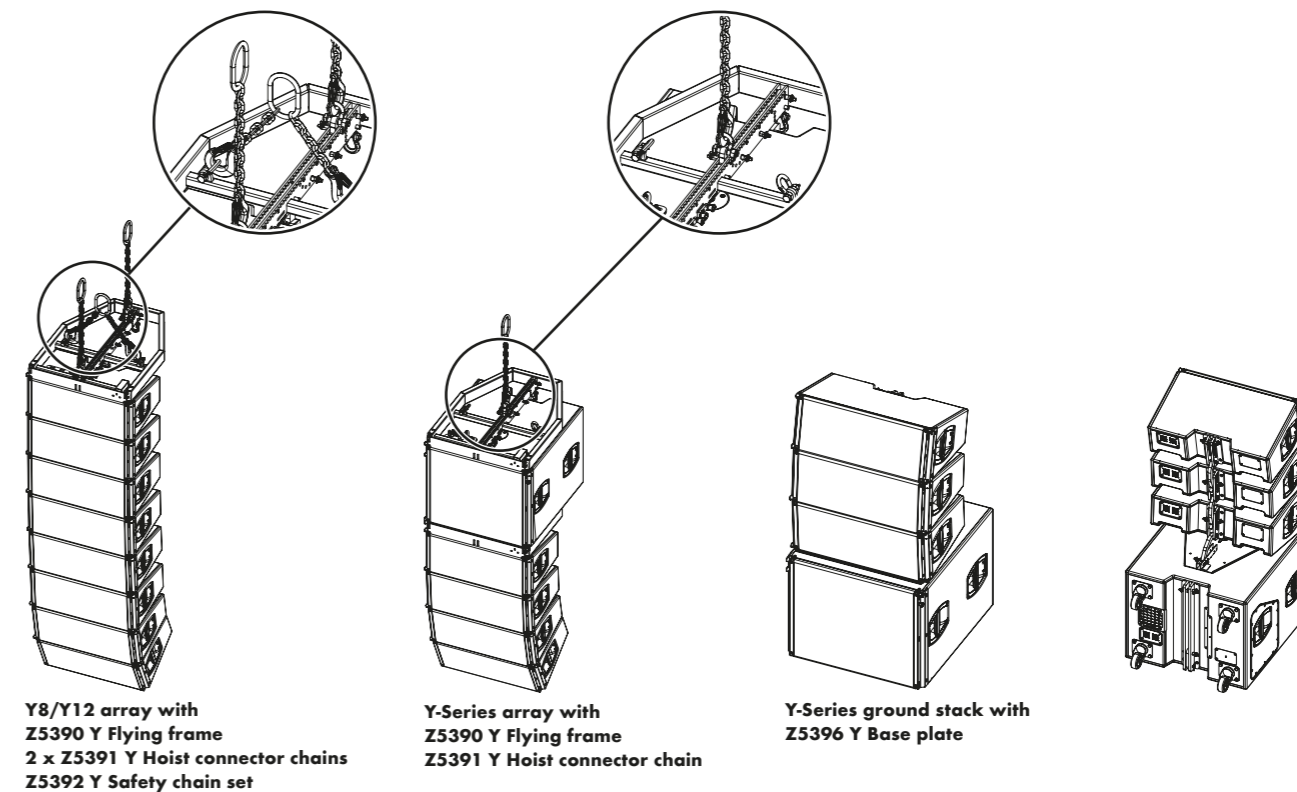

Y8/Y12 array with Z5390 Y Flying frame 2 x Z5391 Y Hoist connector chains Z5392 Y Safety chain set

Y-Series array with Z5390 Y Flying frame Z5391 Y Hoist connector chain

Y-Series ground stack with Z5396 Y Base plate

The Yi8, Yi12 and Yi-SUB rigging examples

Safety approval

d&b loudspeakers and accessories are designed for setup and use within situations requiring compliance with the provisions and directives of the DGUV regulation 17 (formerly BGV C1).

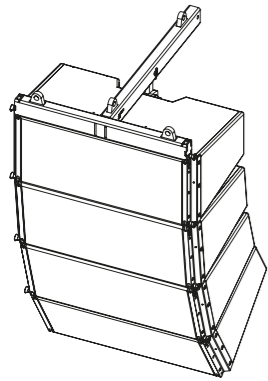

Yi8/Yi12 array with
Z5393.000 Y Mounting frame top

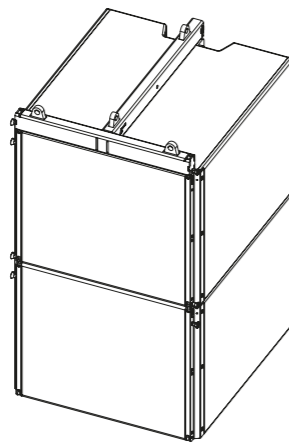

Yi-SUB column with
Z5393.000 Y Mounting frame top

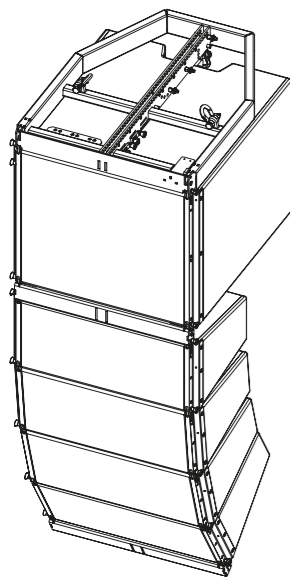

Yi array with
Z5390 Y Flying frame
2 x Z5393.001 Y Mounting frame bottom

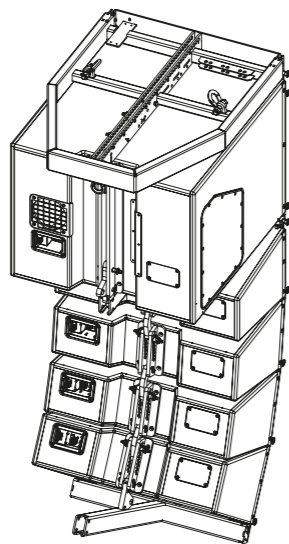

The Yi Weather Resistant and Special Colour options

The Yi cabinets and appropriate accessories are also available with a Weather Resistant or Special Colour option. Both options can be combined.

Weather Resistant (WR) option

The WR option enables operation of loudspeakers in changing ambient conditions, however it is not intended to enable permanent, unprotected operation of loudspeakers outdoors. A cover must also be positioned over the loudspeakers. Cabinets used outdoors even with the WR option should always be aimed either horizontally or with a downward tilt. The Yi-SUB should always be positioned without any vertical tilt. Yi loudspeakers with the Weather Resistant option are supplied with a fixed cable. PG cable type H07RN-F 2 x 2.5 mm²/AWG 13 with a length of 5.5 m (18 ft) as standard or length as required. Additionally, the Yi loudspeakers supplied with the WR option, based on a PCP finish (Polyurea Cabinet Protection), are also available in RAL colour versions.

Special Colour (SC) option

The paint finish of all loudspeaker cabinets and most accessories can be executed in almost all RAL colours in accordance with the RAL colour table. All rigging fittings at the rear of the cabinet, Front links and Locking pins remain in black. Other paint finishes such as metallic are available on request. The acoustically transparent foam fitted behind the rigid metal grill is also painted with the requested RAL colour.

The d&b ArrayCalc simulation software

The d&b ArrayCalc simulation software is the simulation tool for d&b line arrays, column and point source loudspeakers as well as subwoofers. This is a comprehensive toolbox for all tasks associated with acoustic design, performance prediction, alignment, rigging and safety parameters. For safety reasons d&b line arrays must be designed using the d&b ArrayCalc simulation software. d&b ArrayCalc is available as a native stand-alone application for both Microsoft Windows¹ (Win7 or higher) and Mac OS X² (10.6 or higher) operating systems. Listening planes can be defined in the venue tab, creating a three dimensional representation of any audience area in a given venue. All sources can be time aligned, additionally the phase response of a flown system and a ground stacked SUB array can be calculated at a definable reference point. The level distribution resulting from the interaction of all active sources can be mapped onto the previously defined audience areas in a three-dimensional view, which can also be zoomed, rotated and exported as a graphics file. The Remote ID for all devices can be managed in the amplifier tab. EASE and DXF data export capabilities are also available.

The ArrayProcessing function applies powerful filter algorithms to optimize the tonal (spectral) and level (spatial) performance of a line array column over the audience area defined by its mechanical vertical coverage angle. Within the d&b ArrayCalc simulation software, spectral and level performance targets over the listening areas can be defined while specific level drops or offsets can be applied to certain areas, to assign reduced level zones. ArrayProcessing applies a combination of FIR and IIR filters to each individual cabinet in an array to achieve the targeted performance, with an additional latency of only 5.9 ms. This significantly improves the linearity of the response over distance as well as seamlessly correcting for air absorption. In addition, ArrayProcessing employs the same frequency response targets for all d&b line arrays, to ensure all systems share a common tonality. This provides consistent sonic results regardless of array length or splay settings. The resulting coverage is enhanced with spectral consistency and defined level distribution, achieving more linear dispersion and total system directivity to cover longer distances or steep listening areas effectively. The R1 Remote control software uses the data defined in ArrayCalc to generate an intuitive graphical user interface including complete details of the simulated system, including loudspeakers, amplifiers, remote IDs, groups, ArrayProcessing data and all configuration information. This workflow removes the need to manually transfer data from one software program to the other.

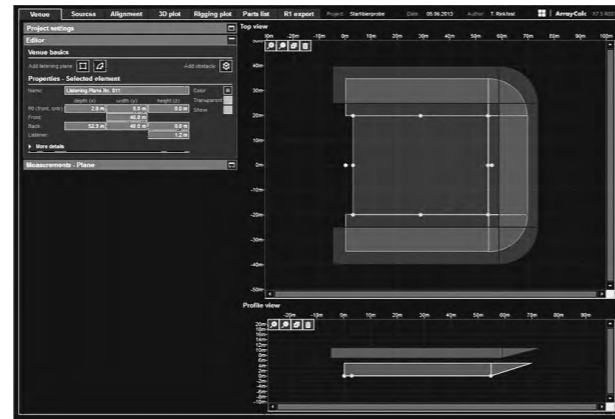

Venue editor

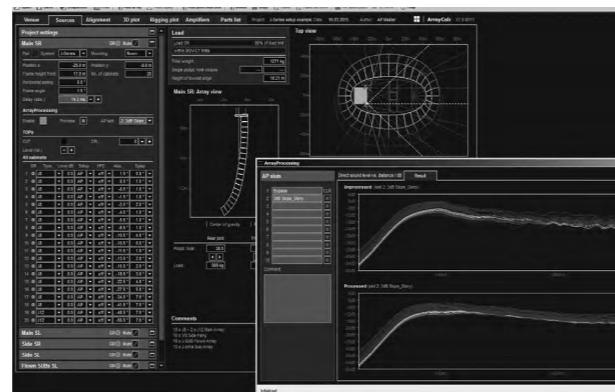

ArrayProcessing

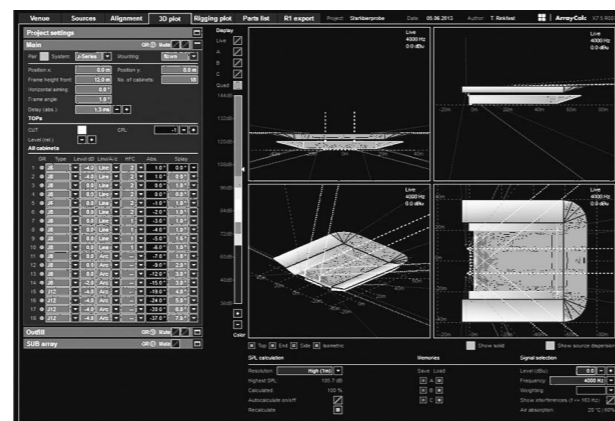

3D Plot quad

The d&b Remote network

The remote control capability of the d&b Remote network enables central control and monitoring of a complete d&b loudspeaker system from anywhere in the network, be it from a computer in the control room, at the mix position, or on a wireless tablet in the auditorium. This central access to all functions through the d&b Remote network, to controls as well as detailed system and device diagnostics information, unlocks the full potential of the d&b system approach. In a typical user workflow, the d&b Remote network takes settings optimized in the ArrayCalc simulation software and applies these to all the amplifiers within the network. The importation of settings from ArrayCalc allows the system configuration to be quickly accomplished, providing more time for verification and fine tuning.

All features, functions and controls available on the front panel of d&b amplifiers may be remotely controlled and/or monitored using R1 Remote control software. This allows each channel of the amplifier to be controlled and enables the creation of groups of loudspeakers. When grouped together, a button or fader can control the overall system level, zone level, equalization and delay, power ON/OFF, MUTE, as well as loudspeaker specific function switches such as CUT/HFA/HFC and CPL. An offline mode is provided for preparation in advance of an event, without the amplifiers being present or connected.

For mobile applications, d&b System check verifies that the system performs within a predefined condition. Extensive facilities for storing and recalling system settings are provided allowing these to be repeated, as and when required. Project files can be easily adjusted for use with a different set of equipment at another location.

In installation projects system integrators can configure the d&b Remote network to offer access to different levels of control, tailored to the operational demands. For example, power ON/OFF for daily use, or more complex functionality for detailed control. Password protection is available to restrict access. Input and Load monitoring allow installation operators to ensure optimum performance at all times.

R1 Remote control software enables d&b amplifiers to be remotely controlled using both Ethernet and CAN-Bus in parallel. The software is optimized for use with touch screen, mouse and keyboard and runs on both Microsoft Windows¹ (Win7 or higher) and Mac OS X² (10.6 or higher) operating systems.

Further information is provided in the d&b Amplifier and Software brochure which is available for download at www.dbaudio.com.

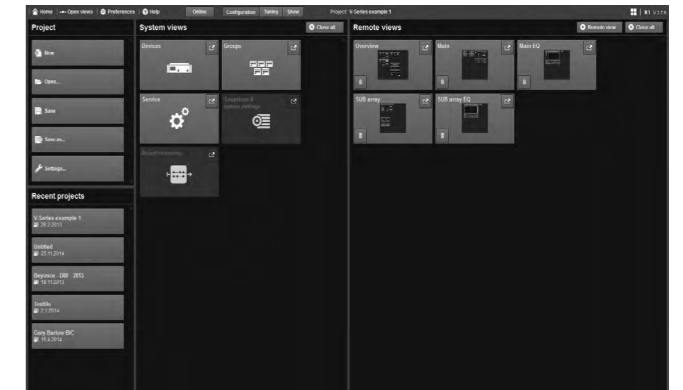

Home



Remote in Configuration mode



Open views

¹ Microsoft Windows is a registered trademark or trademark of Microsoft Corporation in the United States and/or other countries
² Mac OS is a trademark of Apple Inc., registered in the U.S. and other countries

The d&b amplifiers

The d&b amplifiers are designed specifically to power d&b loudspeakers and are the beating heart of the d&b System reality. As such, they incorporate Digital Signal Processing for comprehensive loudspeaker management, switchable filter functions, remote capabilities and user-definable controls, to fulfil the exact needs of each application. Every loudspeaker configuration combines comprehensive system limiting, and equalization and crossover settings to ensure consistent results and optimal performance. d&b amplifiers offer

different output configurations for different loudspeaker setups, including Dual Channel mode, for passive setups, Mix TOP/SUB mode, in which two channels are driven through a single output connector, and 2-Way Active mode, which also sends the output of two channels down one connector to drive appropriate loudspeakers actively. The d&b switch functions provide selected filters to precisely tailor a wide variety of setups to their applications. Examples of these switch functions are the CSA (Cardioid Subwoofer Array)

and HFC (High Frequency Compensation) modes. CSA increases low frequency directivity control by minimising energy transmission towards the rear while HFC compensates for air absorption for loudspeakers covering far field listening positions. In addition to these functions, d&b amplifiers offer a comprehensive set of specific filters such as CUT, a cut mode for TOP loudspeakers when used with d&b subwoofers; CPL, to compensate for the coupling effect between loudspeakers in close proximity to other loudspeakers or hard objects and HFA

mode, to attenuate the high frequencies of a loudspeaker to mimic the effect of far field listening. These devices offer extended, user-definable equalization and delay capabilities, eliminating the need for external processing devices in the signal chain. All d&b amplifiers integrate with the d&b Remote network to enable the remote control and management of systems from anywhere within a network. Further information is provided in the d&b Amplifier and Software brochure which is available for download at www.dbaudio.com.

Comparison of the d&b amplifiers

	D80	30D	D20	10D	D6	D12
User interface	Encoder/colour TFT touchscreen	LED indicators	Encoder/colour TFT touchscreen	LED indicators	Encoder/LC display	Encoder/LC display
Output channels	4	4	4	4	2	2
Input channels	4 x AES or 4 x analog or 2 x AES and 2 x analog	4 x AES and 4 x analog	4 x AES or 4 x analog or 2 x AES and 2 x analog	4 x AES and 4 x analog	2 x AES or 2 x analog	2 x AES or 2 x analog
Latency	0.3 msec	0.3 msec	0.3 msec	0.3 msec	0.3 msec	0.3 msec
User equalizers (per channel)	2 x 16-band	2 x 16-band	2 x 16-band	2 x 16-band	4-band	4-band
Delay	10 sec/3440 m	10 sec/3440 m	10 sec/3440 m	10 sec/3440 m	340 msec/116.9 m	340 msec/116.9 m
Maximum output power (THD+N < 0.5%, 12 dB crest factor)	4 x 2000 W into 8 ohms 4 x 4000 W into 4 ohms	4 x 800 W into 8 ohms 4 x 1600 W into 4 ohms	4 x 800 W into 8 ohms 4 x 1600 W into 4 ohms	4 x 350 W into 8 ohms 4 x 700 W into 4 ohms	2 x 350 W into 8 ohms 2 x 600 W into 4 ohms	2 x 800 W into 8 ohms 2 x 1600 W into 4 ohms
Output routing	Dual Channel, Mix TOP/SUB 2-Way Active	Dual Channel, Mix TOP/SUB 2-Way Active	Dual Channel, Mix TOP/SUB 2-Way Active	Dual Channel, Mix TOP/SUB 2-Way Active	Dual Channel	Dual Channel, Mix TOP/SUB 2-Way Active
Output connectors	NL4/EP5 plus central NL8	Phoenix Euroblock	NL4 plus central NL8	Phoenix Euroblock	NL4	NL4/EP5/NL8
GPIO connector, 5 ports	No	Phoenix Euroblock	No	Phoenix Euroblock	No	No
Cable compensation	LoadMatch	LoadMatch	LoadMatch	LoadMatch	No	SenseDrive
Power supply	Autosensing switched mode power supply with active PFC	Universal range switched mode power supply with active PFC	Universal range switched mode power supply with active PFC	Universal range switched mode power supply with active PFC	Autosensing switched mode power supply with active PFC	Autosensing switched mode power supply
Mains voltage	100 - 127/208 - 240 V, 50 - 60 Hz	100 - 240 V, 50 - 60 Hz	100 - 240 V, 50 - 60 Hz	100 - 240 V, 50 - 60 Hz	100 - 120/220 - 240, 50 - 60 Hz	115/230 V or 100/200 V, 50 - 60 Hz
Weight (kg/lb)	19/42	10.6 / 23.4	10.8/23.8	10.6 / 23.4	8/17.6	13/28.7
Dimensions	2 RU x 19" x 530 mm	2 RU x 19" x 435 mm	2 RU x 19" x 460 mm	2 RU x 19" x 435 mm	2 RU x 19" x 353 mm	3 RU x 19" x 353 mm
Remote	OCA via Ethernet/CAN	OCA via Ethernet/CAN	OCA via Ethernet/CAN	OCA via Ethernet/CAN	CAN	CAN
Airflow						

The operation with d&b amplifiers

Amplifier controller setups

Arc and Line setups

The Arc mode is intended for line array loudspeakers when used in curved array sections. The Line mode is used for long throw array sections with three or more consecutive splay settings of 0°, 1° or 2°. Compared to the Arc mode, the mid/high range is reduced to compensate for the extended near field.

CUT mode

Set to CUT, the cabinet low frequency level is reduced and is configured for use with d&b active subwoofers.

HFC mode

Selecting the HFC (High Frequency Compensation) mode compensates for loss of high frequency energy due to absorption in air when loudspeakers are used to cover far field listening positions. HFC has two settings which should be used selectively, HFC1 for cabinets covering distances larger than 25 m (82 ft) and HFC2 for those covering distances larger than 50 m (164 ft). This can be used to achieve the correct sound balance between close and remote audience areas allowing all amplifiers driving the array to be fed from the same signal source. Thus the whole array performs with comparable headroom.

HFA mode

In HFA mode (High Frequency Attenuation), the HF response of the system is rolled off. The HFA provides a natural, balanced frequency response when a unit is placed close to listeners in near field or delay use. HFA begins gradually at 1 kHz, dropping by approximately 3 dB at 10 kHz. This roll off mimics the decline in frequency response experienced when listening to a system from a distance in a typically reverberant room or auditorium.

CPL function

The CPL (Coupling) function compensates for coupling effects between the cabinets of an array. CPL begins gradually around 1 kHz, with the maximum attenuation below 100 Hz. As coupling effects increase with the length of the line array, the CPL circuit can be set to dB attenuation values between 0 and -9.

100 Hz mode

The 100 Hz mode limits the upper operating frequency of the subwoofer to 100 Hz, complementing top cabinets in full range mode.

CSA mode

CSA (Cardioid Subwoofer Array) mode enables the combination of three or multiples of three B6-SUB cabinets within an array producing exceptional low frequency directivity control. The amplifier channel for the centre subwoofer of the column, which is physically pointed to the rear, has CSA selected. The forward facing cabinets are driven with an amplifier channel set in the standard mode. The resulting cardioid behaviour of the array will significantly reduce the energy radiated to the rear. For further information please refer to the d&b TI 330 Cardioid Subwoofer Array, which is available for download at www.dbaudio.com.

Recommended amplifiers for mobile applications

	Y7P	Y10P	B6	Y8	Y12	Y-SUB
D80	x	x	x	x	x	x

Recommended amplifiers for installation applications

	Yi7P	Yi10P	Bi6	Yi8	Yi12	Yi-SUB
D80	x	x	x	x	x	x
30D	x	x	x	x	x	x

Maximum loudspeakers per amplifier channel

	Y7P Yi7P	Y10P Yi10P	B6 Bi6	Y8 Yi8	Y12 Yi12	Y-SUB Yi-SUB
	2	2	2	2	2	2

Available controller settings

	Y7P Yi7P	Y10P Yi10P	B6 Bi6	Y8 Yi8	Y12 Yi12	Y-SUB Yi-SUB
Arc/Line				x	x	
CUT	x	x		x	x	
HFC				x	x	
HFA	x	x				
CPL	x	x		x	x	
100 Hz			x			x
CSA			x			

The Y-Series frequency responses

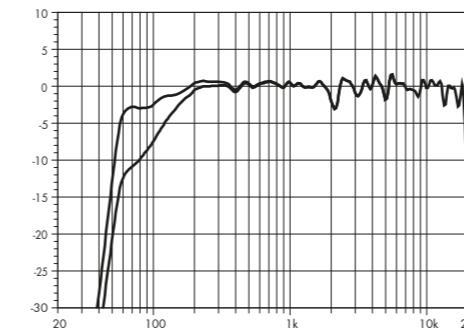

Y7P/Yi7P standard and CUT

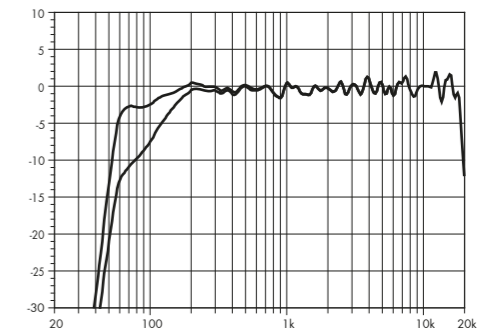

Y10P/Yi10P standard and CUT

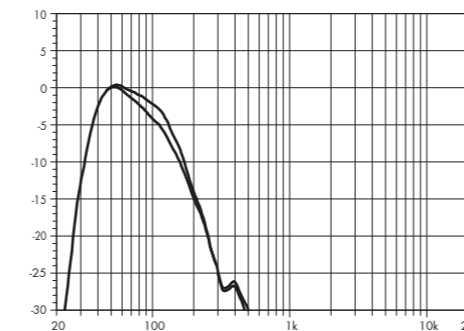

B6-SUB/Bi6-SUB standard and 100 Hz

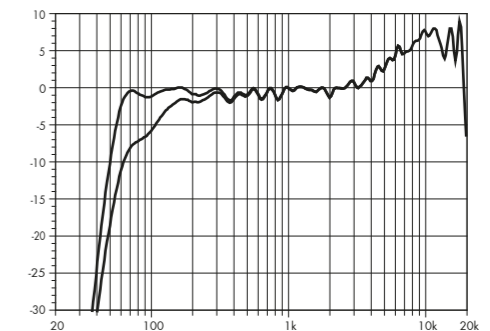

Y8/Yi8 standard and CUT (single cabinet)

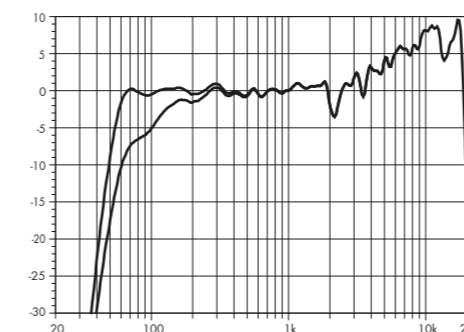

Y12/Yi12 standard and CUT (single cabinet)

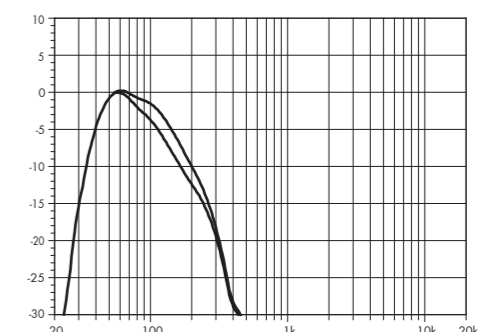

Y-SUB/Yi-SUB standard and 100 Hz

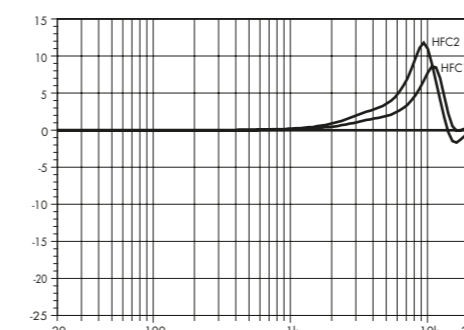

Correction of HFC

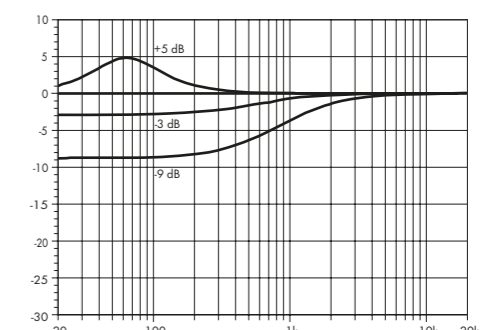

Correction of CPL

The d&b amplifier output modes

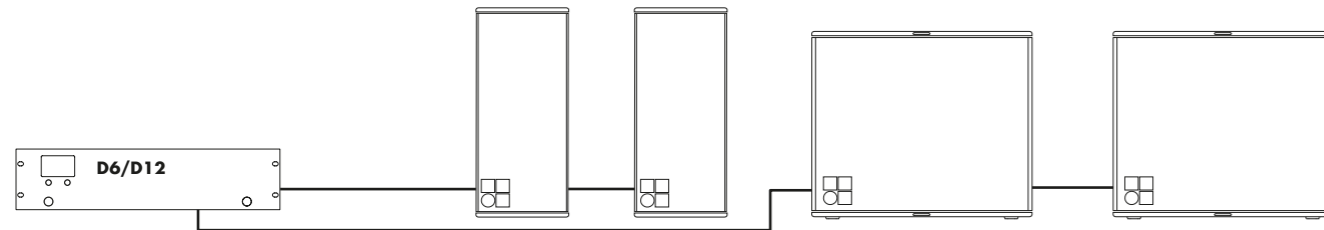

D6/D12 amplifier in Dual Channel mode for Y7P, Y10P, Yi7P, Yi10P, Y8, Y12, Yi8, Yi12 as well as B6-SUB, Bi6-SUB, Y-SUB and Yi-SUB

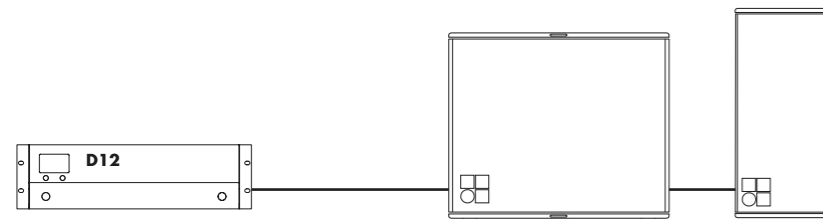

D12 amplifier in Mix TOP/SUB mode for Y7P, Y10P, Yi7P, Yi10P, Y8, Y12, Yi8 or Yi12 and B6-SUB, Bi6-SUB, Y-SUB or Yi-SUB

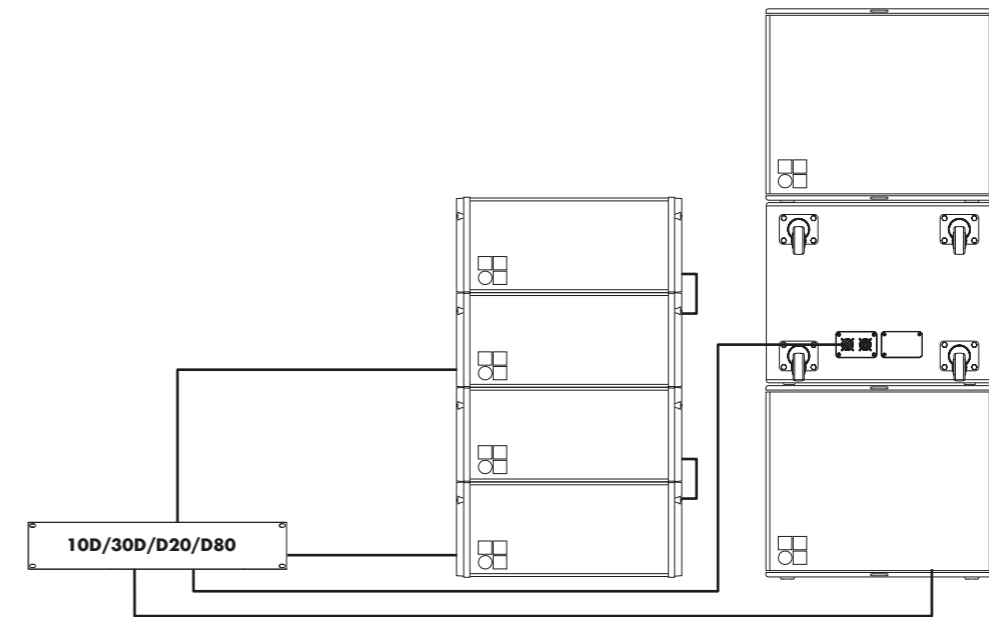

10D/30D/D20/D80 amplifier in Dual Channel mode for Y7P, Y10P, Yi7P, Yi10P, Y8, Y12, Yi8, Yi12 as well as B6-SUB, Bi6-SUB, Y-SUB and Yi-SUB (B6-SUB as CSA)

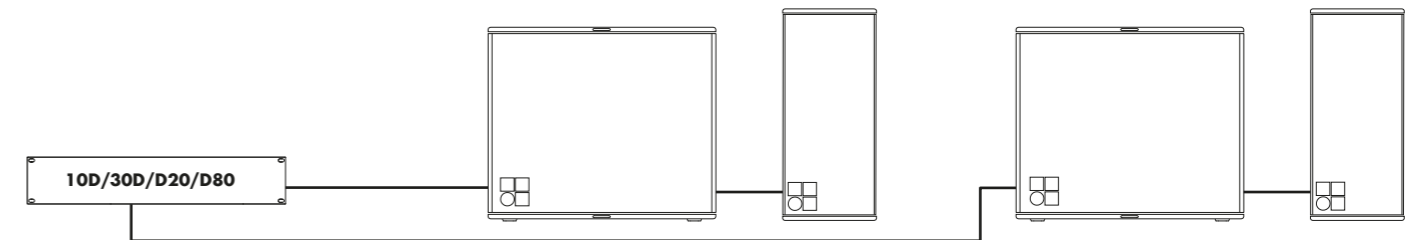

10D/30D/D20/D80 amplifier in Mix TOP/SUB mode for Y7P, Y10P, Yi7P, Yi10P, Y8, Y12, Yi8 or Yi12 and B6-SUB, Bi6-SUB, Y-SUB or Yi-SUB

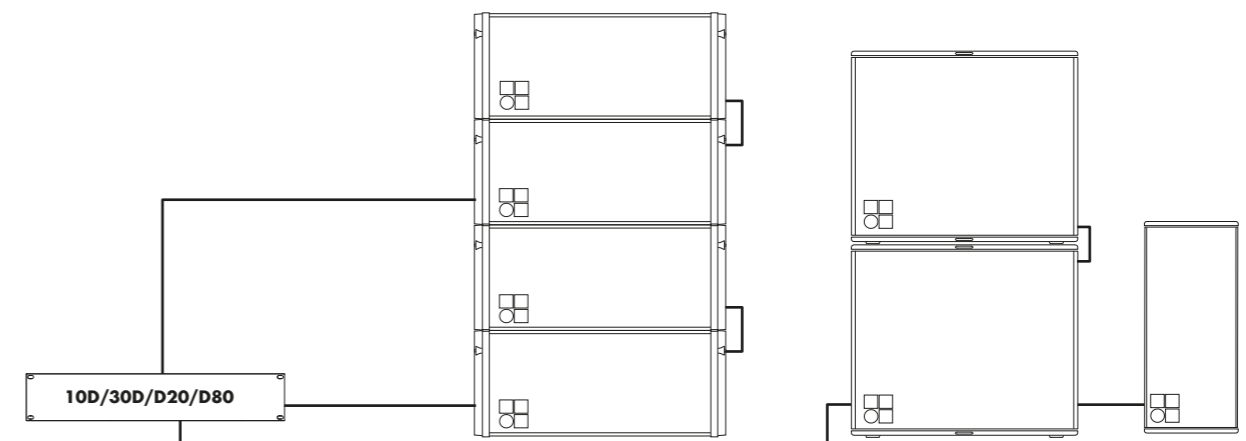

10D/30D/D20/D80 amplifier in a mixed configuration of Dual Channel and Mix TOP/SUB mode for Y7P, Y10P, Yi7P, Yi10P, Y8, Y12, Yi8 or Yi12 and B6-SUB, Bi6-SUB, Y-SUB or Yi-SUB

The Y-Series cables and adapters

Amplifiers in Dual Channel mode

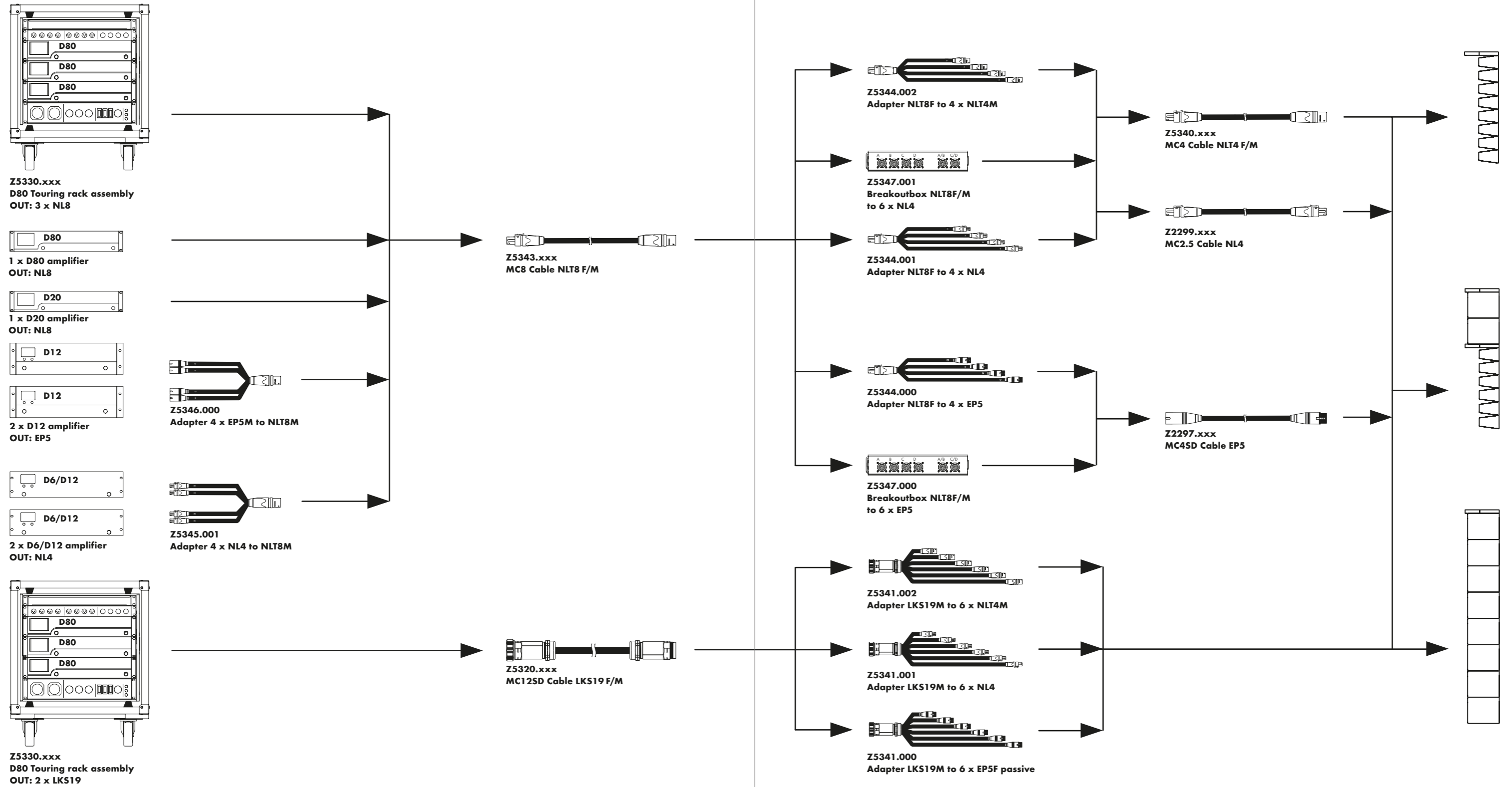

The Y-Series configuration examples

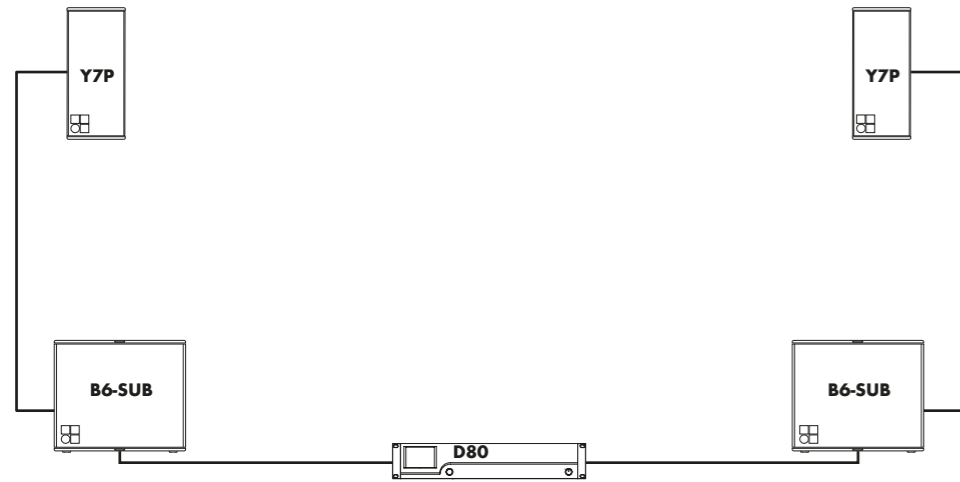

Y-Series L/R configuration comprising Y7P and B6-SUB with a D80 amplifier in Mix TOP/SUB mode¹

¹ These configuration examples are also valid for Yi loudspeakers

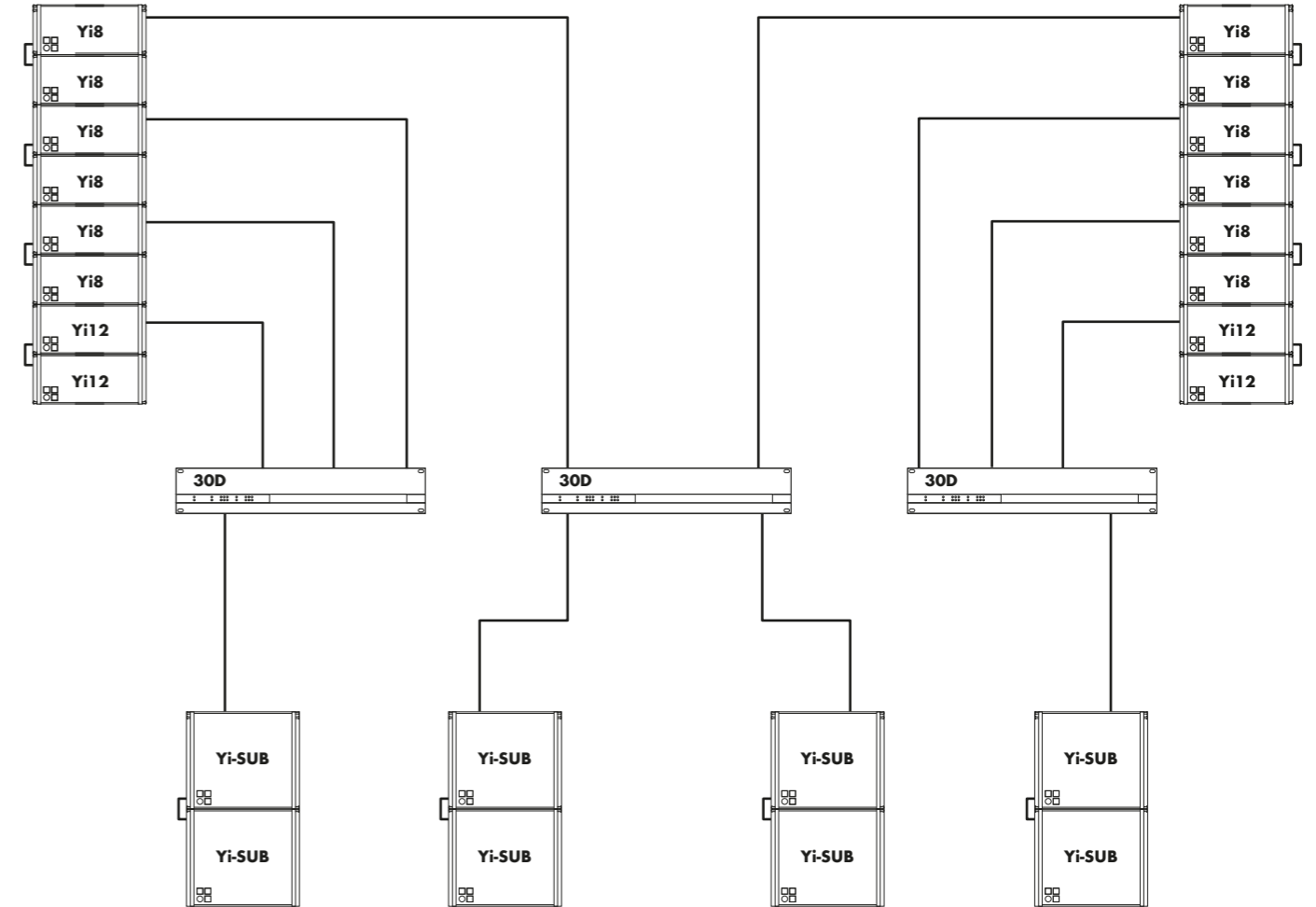

Yi line array in L/R configuration with flown Yi8/Yi12s and ground stacked Yi-SUBs with 30D amplifiers in Dual Channel mode¹

¹ These configuration examples are also valid for Y8/Y12/Y-SUBs

The Y-Series configuration examples

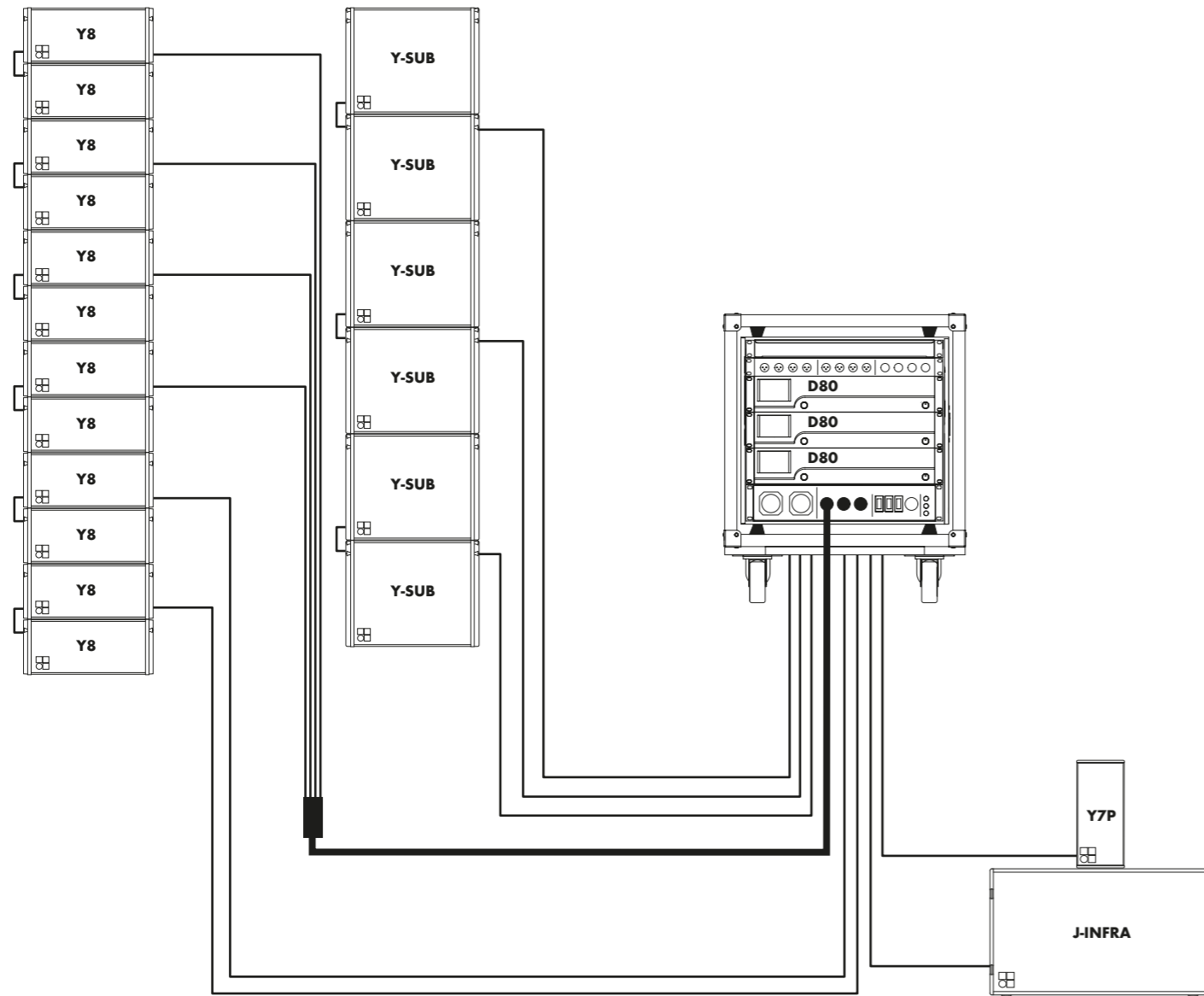

Y-Series configuration comprising Y8 and Y-SUB flown array with ground stacked J-INFRA and Y7P as nearfill with D80 Touring rack¹

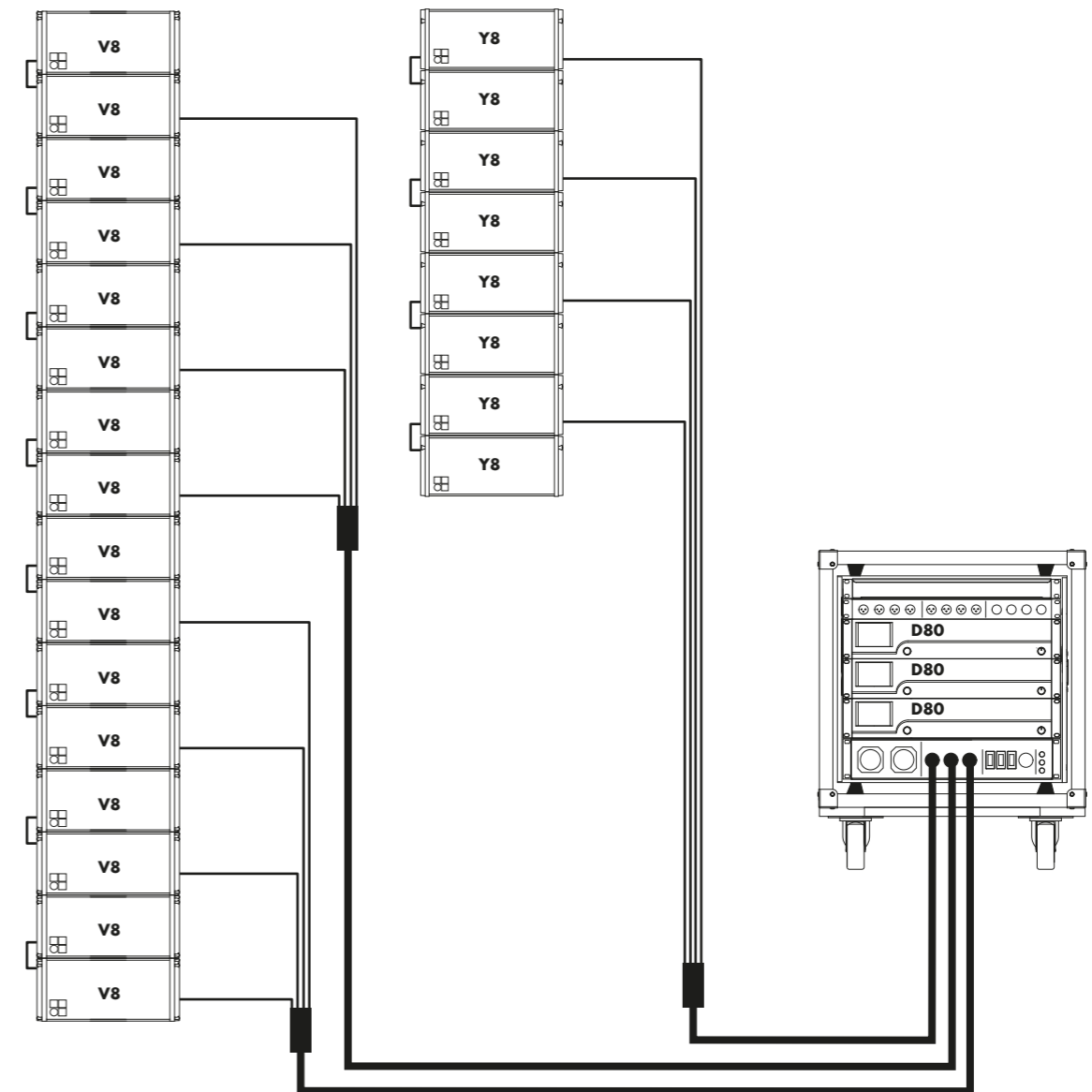

Mixed configuration comprising V8 main array with Y8 outfills with D80 Touring rack¹

The Y-Series configuration examples

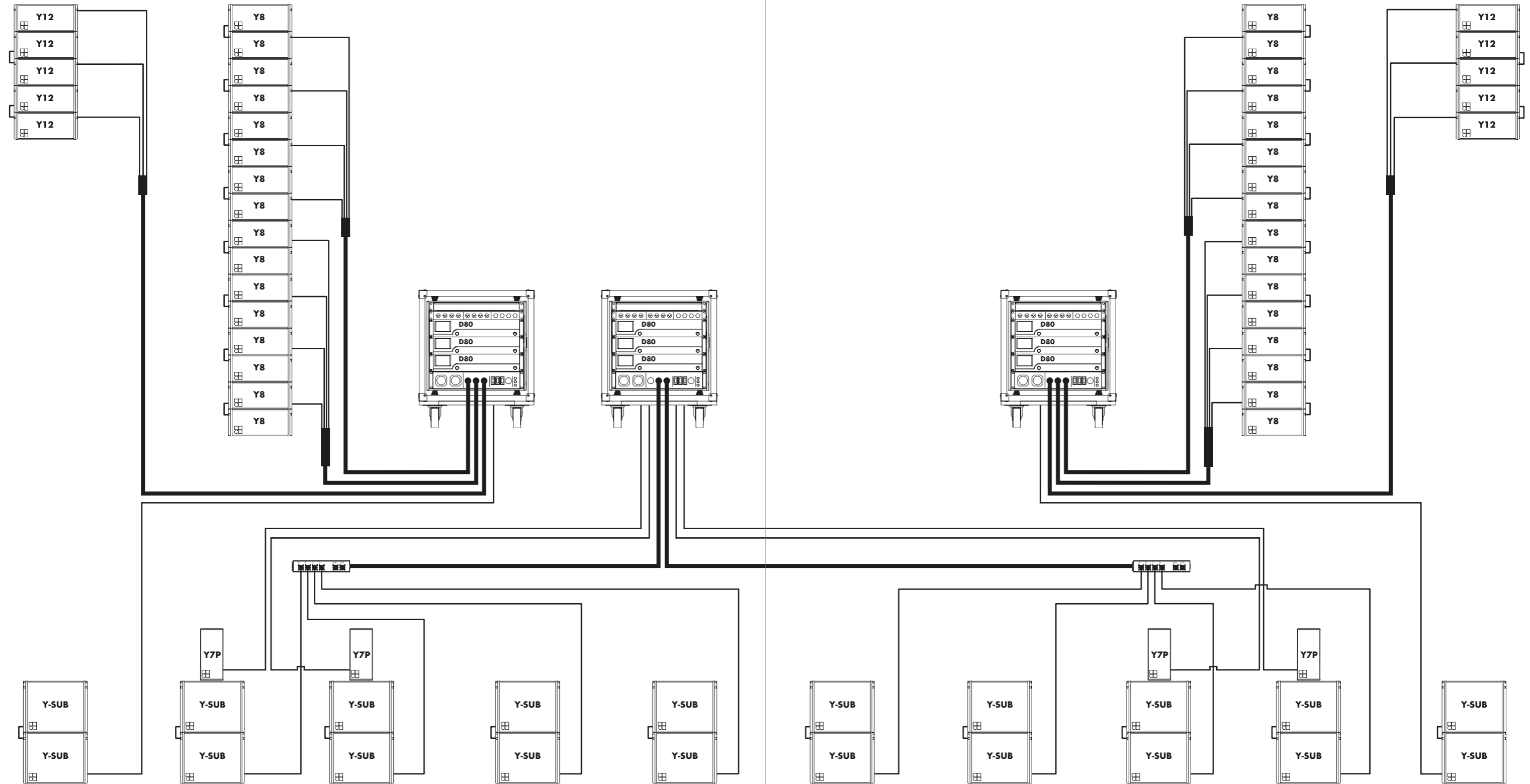

Y-Series configuration comprising Y8 mains and Y12 outfill arrays along with ground stacked Y-SUBs and Y7P as nearfills with D80 Touring racks¹

¹ These configurations are also valid for Yi loudspeakers

The Y-Series product overview

Y loudspeakers	Z0702.xxx Z0703.xxx Z0710.xxx Z0707.xxx Z0708.xxx Z0709.xxx	Y7P Loudspeaker Y10P Loudspeaker B6 Subwoofer Y8 Loudspeaker Y12 Loudspeaker Y Subwoofer
Loudspeaker connector options	Zxxxx.002 Zxxxx.000 Zxxxx.001	NLT4 F/M connector EP5 connector NL4 connector
Yi loudspeakers	Z0712.001 Z0713.001 Z0711.001 Z0717.001 Z0718.001 Z0719.001	Yi7P Loudspeaker NL4 connector Yi10P Loudspeaker NL4 connector Bi6 Subwoofer NL4 connector Yi8 Loudspeaker NL4 connector Yi12 Loudspeaker NL4 connector Yi Subwoofer NL4 connector WR Weather Resistant option ¹ SC Special Colour option ²
Loudspeaker cases	E7473.000 E7472.000 E7475.000	Touring case 2 x Y7P/Y10P Touring case 4 x Y8/Y12 Touring case 2 x Y Flying frame
Loudspeaker carts	E7470.000 E7471.000	Touring cart 4 x Y8/Y12 Touring cart 8 x Y8/Y12
Lids	E7925.000 E7924.000	B6-SUB Transport lid Y-SUB Transport lid
YP accessories	Z5397.000 Z5398.000 Z5399.000 Z5389.000 Z5010.000 Z5012.500 Z5049.000 Z5013.000 Z5009.000 Z5024.000	YP Swivel bracket YP Horizontal bracket ³ YP Mounting bracket ³ Bi6-SUB Horizontal bracket ³ TV spigot with fixing plate Pipe clamp for TV spigot Flying pin 8mm Loudspeaker stand winder M20 Loudspeaker stand with winder Loudspeaker stand adapter
Y accessories	Z5390.000 Z5394.000 Z5393.000 Z5393.001 Z5396.000 Z5391.000 Z5392.000	Y Flying frame ³ Y Flying adapter ³ Y Mounting frame top ³ Y Mounting frame bottom ³ Y Base plate Y Hoist connector chain Y Safety chainset

¹ WR only for Yi loudspeakers, on request
² SC only for Yi loudspeakers, on request
³ SC on request

	Z5147.001 E6507.000	Rota clamp 1t Shackle
Remote network	Z3010.000 Z6118.000 Z6124.000 Z6116.000 Z6122.000 Z6123.000	R1 Remote control software ⁴ R60 USB to CAN interface R70 Ethernet to CAN interface RJ 45 M Terminator Bopla mounting clamp Bopla mounting clamp upright
Amplifiers	Z2710.xxx Z2750.xxx Z2770.xxx Z2760.xxx Z2700.xxx Z2600.xxx	D80 Amplifier ⁵ D20 Amplifier NL4 ⁵ 30D Amplifier ⁶ 10D Amplifier ⁶ D6 Amplifier NL4 ⁶ D12 Amplifier ⁵
Amplifier rack assemblies	Z5330.001 Z5330.xxx	D80 Touring rack assembly, CEE 32A 5P ⁷ D80 Touring rack assembly, Nema L21-30 (120V devices) on request ⁷
Amplifier racks	E7480.000 E7468.000 E7419.000 E7420.000	D20 Touring rack 2 RU 19" SD , shock mounted, handles D80 Touring rack 2 RU, 19" SD , shock mounted, handles Touring rack 3 RU, 19" DD , shock mounted, handles, window Touring rack 6 RU, 19" DD , shock mounted, handles, window, wheels
Cables and adapters	Z5343.xxx Z5346.000 Z5345.001 Z5320.xxx Z5344.002 Z5344.001 Z5344.000 Z5347.001 Z5347.000 Z5340.xxx Z2299.xxx Z2297.xxx Z5341.002 Z5341.001 Z5341.000	MC8 Cable NLT8 F/M Adapter 4 x EP5M to NLT8M Adapter 4 x NL4 to NLT8M MC12SD Cable LKS19 F/M Adapter NLT8F to 4 x NLT4M Adapter NLT8F to 4 x NL4 Adapter NLT8F to 4 x EP5 Breakoutbox NLT8 F/M to 6 x NL4 Breakoutbox NLT8 F/M to 6 x EP5 MC4 Cable NLT4 F/M MC2.5 Cable NL4 MC4SD Cable EP5 Adapter LKS19 M to 6 x NLT4M Adapter LKS19 M to 6 x NL4 Adapter LKS19M to 6 x EP5

⁴ available as a download at www.dbaudio.com

⁵ the complete list of mobile amplifier versions is available in the D Amplifier and Software brochure

⁶ the complete list of installation amplifier versions is available in the xD Installation Amplifier and Software brochure

⁷ further information is available in the d&b Amplifier and Software brochure

