

**FRANCHISE DISCLOSURE DOCUMENT
DOMINO'S PIZZA FRANCHISING LLC**

A Delaware limited liability company
24 Frank Lloyd Wright Drive
Ann Arbor, Michigan 48105-9484
(734) 930-3030

franchising@dominos.com
www.dominos.com



The franchisee will operate a Domino's Pizza Store selling pizza and other authorized products through delivery and carry-out services. We offer franchises for Traditional and Non-Traditional Domino's Pizza Stores and related concepts under agreements described in this disclosure document.

The total investment ranges from \$156,450 to \$743,500 for a Domino's Pizza Traditional Store and \$107,450 to \$709,500 for a Domino's Pizza Non-Traditional Store. We estimate the payments made to us and our affiliates together with Initial Fee payments will range from \$88,950 to \$196,500 for a Domino's Pizza Traditional Store and \$69,950 to \$187,500 for a Domino's Pizza Non-Traditional Store.

This disclosure document summarizes certain provisions of your franchise agreement and other information in plain English. Read this disclosure document and all accompanying agreements carefully. You must receive this disclosure document at least fourteen calendar-days before you sign a binding agreement with, or make any payment to, the franchisor or an affiliate in connection with the proposed franchise sale. **Note, however, that no governmental agency has verified the information contained in this document.**

You may wish to receive your disclosure document in another format that is more convenient for you. To discuss the availability of disclosures in different formats contact the Franchise Services Department at Domino's Pizza Franchising LLC at 24 Frank Lloyd Wright Drive, Ann Arbor, Michigan 48105-9484, (734) 930-3030.

The terms of your contract will govern your franchise relationship. Don't rely on the disclosure document alone to understand your contract. Read all of your contracts carefully. Show your contract and this document to an advisor, like a lawyer or an accountant.

Buying a franchise is a complex investment. The information in this disclosure document can help you make up your mind. More information on franchising, such as "*A Consumers's Guide to Buying a Franchise*," which can help you understand how to use this disclosure document, is available from the Federal Trade Commission ("FTC"). You can contact the FTC at 1-877-FTC-

HELP or by writing to the FTC at 600 Pennsylvania Avenue NW, Washington, D.C. 20580. You can also visit the FTC's home page at www.ftc.gov for additional information. Call your state agency or visit your public library for other sources of information on franchising.

There may also be laws about franchising in your state. Ask your state agencies about them.

Issuance date: April 1, 2024, as amended July 31, 2024.

How to Use This Franchise Disclosure Document

Here are some questions you may be asking about buying a franchise and tips on how to find more information:

QUESTION	WHERE TO FIND INFORMATION
How much can I earn?	Item 19 may give you information about outlet sales, costs, profits or losses. You should also try to obtain this information from others, like current and former franchisees. You can find their names and contact information in Item 20 or Exhibit B.
How much will I need to invest?	Items 5 and 6 list fees you will be paying to the franchisor or at the franchisor's direction; Item 7 lists the initial investment to open, and Item 8 describes the suppliers you must use.
Does the franchisor have the financial ability to provide support to my business?	Exhibits C and D include financial statements. Review these statements carefully.
Is the franchise system stable, growing, or shrinking?	Item 20 summarizes the recent history of the number of company-owned and franchised outlets.
Will my business be the only Domino's Pizza business in my area?	Item 12 and the "territory" provisions in the franchise agreement describe whether the franchisor and other franchisees can compete with you.
Does the franchisor have a troubled legal history?	Items 3 and 4 tell you whether the franchisor or its management have been involved in material litigation or bankruptcy proceedings.
What's it like to be a Domino's Pizza franchisee?	Exhibit B lists current and former franchisees. You can contact them to ask about their experiences.
What else should I know?	These questions are only a few things you should look for. Review all 23 Items and all Exhibits in this disclosure document to better understand this franchise opportunity. See the table of contents.

What You Need To Know About Franchising *Generally*

Continuing responsibility to pay fees. You may have to pay royalties and other fees even if you are losing money.

Business Model Can Change. The franchise agreement may allow the franchisor to change its manuals and business model without your consent. These changes may require you to make additional investments in your franchise business or may harm your franchise business.

Supplier restriction. You may have to buy or lease items from the franchisor or a limited group of suppliers the franchisor designates. These items may be more expensive than similar items you could buy on your own.

Operating restrictions. The franchise agreement may prohibit you from operating a similar business during the term of the franchise. There are usually other restrictions. Some examples may include controlling your location, access to customers, what you sell, how you market, and your hours of operation.

Competition from franchisor. Even if the franchise agreement grants you a territory, the franchisor may have the right to compete with you in your territory.

Renewal. Your franchise agreement may not permit you to renew. Even if it does, you may have to sign a new agreement with different terms and conditions in order to continue to operate your franchise business.

When your franchise ends. The franchise agreement may prohibit you from operating a similar business after your franchise ends even if you still have obligations to your landlord or other creditors.

Some States Require Registration

Your state may have a franchise law, or other law, that requires franchisors to register before offering or selling franchises in the state. Registration does not mean that the state recommends the franchise or has verified the information in this document. To find out if your state has a registration requirement, or to contact your state, use the agency information in Exhibit A.

Your state also may have laws that require special disclosures or amendments be made to your franchise agreement. If so, you should check the State Specific Addenda. See the Table of Contents for the location of the State Specific Addenda.

Special Risks to Consider About *This* Franchise

Check the “State Specific Addenda” (if any) to see whether your state requires risks to be highlighted.

THE FOLLOWING APPLY TO TRANSACTIONS GOVERNED BY
MICHIGAN FRANCHISE INVESTMENT LAW ONLY

THE STATE OF MICHIGAN PROHIBITS CERTAIN UNFAIR PROVISIONS THAT ARE SOMETIMES IN FRANCHISE DOCUMENTS. IF ANY OF THE FOLLOWING PROVISIONS ARE IN THESE FRANCHISE DOCUMENTS, THE PROVISIONS ARE VOID AND CANNOT BE ENFORCED AGAINST YOU.

Each of the following provisions is void and unenforceable if contained in any documents relating to a franchise:

- a. A prohibition on the right of a franchisee to join an association of franchisees.
- b. A requirement that a franchisee assent to a release, assignment, novation, waiver, or estoppel which deprives a franchisee of rights and protection provided in this act. This shall not preclude a franchisee, after entering into a franchise agreement, from settling any and all claims.
- c. A provision that permits a franchisor to terminate a franchise prior to the expiration of its term except for good cause. Good cause shall include the failure of the franchisee to comply with any lawful provision of the franchise agreement and to cure such failure after being given written notice thereof and a reasonable opportunity, which in no event need be more than 30 days, to cure such failure.
- d. A provision that permits a franchisor to refuse to renew a franchise without fairly compensating the franchisee by repurchase or other means for the fair market value at the time of expiration of the franchisee's inventory, supplies, equipment, fixtures, and furnishings. Personalized materials which have no value to the franchisor and inventory, supplies, equipment, fixtures, and furnishings not reasonably required in the conduct of the franchise business are not subject to compensation. This subsection applies only if: (i) The term of the franchise is less than 5 years and (ii) the franchisee is prohibited by the franchise or other agreement from continuing to conduct substantially the same business under another trademark, service mark, trade name, logotype, advertising, or other commercial symbol in the same area subsequent to the expiration of the franchise or the franchisee does not receive at least 6 months advance notice of franchisor's intent not to renew the franchise.
- e. A provision that permits the franchisor to refuse to renew a franchise on terms generally available to other franchisees of the same class or type under similar circumstances. This section does not require a renewal provision.
- f. A provision requiring that arbitration or litigation be conducted outside this state. This shall not preclude the franchisee from entering into an agreement, at the time of arbitration, to conduct arbitration at a location outside this state.
- g. A provision which permits a franchisor to refuse to permit a transfer of ownership of a franchise, except for good cause. This subdivision does not prevent a franchisor from exercising a right of first refusal to purchase the franchise. Good cause shall include, but is not limited to:

(1) The failure of the proposed transferee to meet the franchisor's then current reasonable qualifications or standards.

(2) The fact that the proposed transferee is competitor of the franchisor or sub-franchisor.

(3) The unwillingness of the proposed transferee to agree in writing to comply with all lawful obligations.

(4) The failure of the franchisee or proposed transferee to pay any sums owing to the franchisor or to cure any default in the franchise agreement existing at the time of the proposed transfer.

h. A provision that requires the franchisee to resell to the franchisor items that are not uniquely identified with the franchisor. This subdivision does not prohibit a provision that grants to a franchisor a right of first refusal to purchase the assets of a franchise on the same terms and conditions as a bona fide third party willing and able to purchase those assets, nor does this subdivision prohibit a provision that grants the franchisor the right to acquire the assets of a franchise for the market or appraised value of such assets if the franchisee has breached the lawful provisions of the franchise agreement and has failed to cure the breach in the manner provided in subdivision (c).

i. A provision which permits the franchisor to directly or indirectly convey, assign, or otherwise transfer its obligations to fulfill contractual obligations to the franchisee unless provision has been made for providing the required contractual services.

If the franchisor's most recent financial statements are unaudited and show a net worth of less than \$100,000.00, the franchisee may request the franchisor to arrange for the escrow of initial investment and other funds paid by the franchisee until the obligations, if any, of the franchisor to provide real estate, improvements, equipment, inventory, training or other items included in the franchise offering are fulfilled. At the option of the franchisor, a surety bond may be provided in place of escrow.

THE FACT THAT THERE IS A NOTICE OF THIS OFFERING ON FILE WITH THE ATTORNEY GENERAL DOES NOT CONSTITUTE APPROVAL, RECOMMENDATION, OR ENFORCEMENT BY THE ATTORNEY GENERAL.

Any questions regarding this notice should be directed to:

Consumer Protection Division
Antitrust and Franchise Unit
Michigan Department of Attorney General
670 G. Mennen Williams Building
525 West Ottawa
Lansing, Michigan 48933
(517) 373-7177

TABLE OF CONTENTS

<u>ITEM</u>		<u>PAGE</u>
1	The Franchisor, and any Parents, Predecessors, and Affiliates	1
2	Business Experience	5
3	Litigation.....	10
4	Bankruptcy	11
5	Initial Fees.....	11
6	Other Fees	12
7	Estimated Initial Investment	20
8	Restrictions on Sources of Products and Services	24
9	Franchisee's Obligations	30
10	Financing.....	32
11	Franchisor's Assistance, Advertising, Computer Systems, and Training	32
12	Territory	42
13	Trademarks	45
14	Patents, Copyrights and Proprietary Information	46
15	Obligation to Participate in the Actual Operation of the Franchise Business.....	47
16	Restrictions on What the Franchisee May Sell.....	48
17	Renewal, Termination, Transfer and Dispute Resolution.....	48
18	Public Figures	54
19	Financial Performance Representations.....	55
20	Outlets and Franchisee Information.....	58
21	Financial Statements	79
22	Contracts	79
23	Receipts (Last 2 Pages)	

Exhibits

Exhibit A	—	List of State Agencies/Agents for Service of Process
Exhibit B	—	List of Domino’s Pizza Traditional Franchisees
Exhibit B-1	—	List of Domino’s Pizza Non-Traditional Franchisees
Exhibit B-2	—	List of Franchisees Who Have Left the System
Exhibit C	—	DPF Financial Statements
Exhibit D	—	DPL Financial Statements
Exhibit E	—	Traditional Store Standard Franchise Agreement
Exhibit F	—	Non-Traditional Store Franchise Agreement
Exhibit G	—	Development Agreement
Exhibit H	—	Domino’s Pizza Help Desk Services Agreement
Exhibit I	—	Sale of Assets Agreement
Exhibit J	—	Domino’s PULSE Software License Agreement
Exhibit K	—	Expiration of Franchise Agreement and Release
Exhibit L	—	Rider to Lease
Exhibit M	—	Rider to Purchase Agreement
Exhibit N	—	Operating Manual Table of Contents
Exhibit O	—	Application for Franchise (Renewal)
Exhibit P	—	Domino’s Pizza Online Ordering Franchisee Services Agreement
Exhibit Q	—	Term Sheet
Exhibit R	—	Global Positioning System Technology Platform Agreement
Exhibit S	—	Domino’s Rider to Services Agreement

Item 1: The Franchisor, and any Parents, Predecessors, and Affiliates

The Franchisor

The franchisor is Domino's Pizza Franchising LLC. To simplify the language in this disclosure document "we", "us" or "DPF" means Domino's Pizza Franchising LLC. "You" means the person who is buying a franchise. If you are an approved corporation, partnership, limited liability company or other entity, your owners must guarantee and be bound by the Franchise Agreement or other agreement with us as more fully described in this disclosure document. In addition, certain provisions in the Franchise Agreement or other agreement with us apply to your affiliates. You should take this into account when purchasing a franchise.

We are a Delaware limited liability company organized on March 2, 2007. Our principal business address is 24 Frank Lloyd Wright Drive, Ann Arbor, Michigan 48105-9484. Our agents for service of process are disclosed in Exhibit A, as applicable.

Parents and Predecessors

We are a direct wholly-owned subsidiary of Domino's Pizza Master Issuer LLC, a Delaware limited liability company ("DPMI"). Its principal business address is 24 Frank Lloyd Wright Drive, Ann Arbor, Michigan 48105-9484. We are an indirect wholly-owned subsidiary of Domino's Pizza LLC ("DPL"), a Michigan limited liability company. Its principal business address is 30 Frank Lloyd Wright Drive, Ann Arbor, Michigan 48106-0997. DPL was the franchisor of Domino's Pizza franchises before the closing of the 2007 Securitization Transaction described below. DPL is the indirect parent company of DPMI and an indirect wholly-owned subsidiary of Domino's Pizza, Inc., a Delaware corporation ("Domino's" or "DPI"). Domino's is the parent company, directly or indirectly, of all Domino's Pizza related entities.

We and our affiliates are the successors to the business founded by Mr. Thomas S. Monaghan in 1963. In December 1998, Mr. Monaghan sold a substantial portion of his ownership interest in DPI, to investment funds affiliated with Bain Capital, LLC, a private equity firm based in Boston, Massachusetts and retired from the active management of the business. In July 2004, Domino's and certain of its shareholders sold shares in an initial public offering and since that date, Domino's has been a publicly traded company.

Affiliates

We became the franchisor of U.S. franchise agreements entered into after April 2007 as well as other agreements described below as a result of a securitization financing transaction that closed in April 2007 (the "2007 Securitization Transaction"). At the time of the closing of the 2007 Securitization Transaction, DPL entered into a management agreement with DPF and DPMI to provide the required support and services to franchisees under their franchise agreements. DPL also acts as DPF's franchise sales agent. If DPL fails to perform its obligations under its franchise management agreement, then DPL may be replaced as the franchise servicer. However, as the franchisor, DPF is responsible and accountable to you to make sure that all services DPF promises to perform under your franchise agreement, or other agreement you sign with us are performed in

compliance with the applicable agreement, regardless of who performs those services on DPF's behalf.

All U.S. Domino's Pizza trademarks and certain other intellectual property, including substantially all intellectual property related to the operation of Domino's Pizza stores in the United States, are owned by Domino's IP Holder LLC, a Delaware limited liability company ("DP IP Holder") and wholly-owned subsidiary of DPMI. In April 2007 DP IP Holder entered into license agreements with DPF and DPMI for a term of 99 years authorizing these companies to use and sublicense the use of the applicable trademarks and intellectual property in the operation of their respective businesses.

Domino's Pizza Distribution LLC ("DPD"), a Delaware limited liability company and wholly-owned subsidiary of DPMI, sells food products, ingredients, supplies and equipment, and licenses software to Domino's Pizza franchisees and company-owned stores located in the U.S. DPD purchases certain products and items from DPL and certain other affiliated companies for resale to franchisees.

Domino's National Advertising Fund Inc. ("DNAF"), a not-for-profit corporation and a wholly-owned subsidiary of DPL, administers the collections and expenditures of the Advertising Fund. See Item 11. DPL also provides services to DNAF relating to the administration of advertising funds.

Domino's GC Inc., a Florida corporation and a wholly-owned subsidiary of DPL, is in the business of managing the Domino's Pizza gift card program. Its principal business address is 30 Frank Lloyd Wright Drive, Ann Arbor, MI 48106-0997.

Domino's Pizza International Franchising Inc. ("DP International Franchising"), a Delaware corporation and wholly-owned subsidiary of DPMI, acts as franchisor in countries and territories outside of the U.S. As of December 31, 2023, DP International Franchising (directly or through its Master Franchisees) has granted 13,649 franchises.

Domino's Pizza International Franchising of Michigan LLC ("DP International Franchising – Belarus"), a Michigan limited liability company and wholly-owned subsidiary of DP International Franchising, acts as franchisor in Belarus. As of December 31, 2023, DP International Franchising – Belarus has granted 35 franchises.

Various entities affiliated with Domino's entered into several additional secured financing transactions subsequent to the 2007 Securitization Transaction. However, there have been no material changes to the structure of Domino's and its affiliates described in this Item 1 as a result of these subsequent transactions.

Franchise Offering

We are in the business of franchising Domino's Pizza Traditional Stores and Domino's Pizza Non-Traditional Stores. In certain of our branding campaigns, we may reference the brand as "Domino's".

Domino's Pizza Traditional Stores are retail outlets located primarily in shopping centers, strip centers and similar retail locations with appropriate parking for delivery vehicles and customers of the store. In addition, Domino's has entered into an agreement with Walmart which allows for the opening of Domino's Pizza Traditional Stores in select Walmart locations. Domino's Pizza Traditional Stores sell pizza and other authorized products through delivery and carry-out services.

Domino's Pizza Non-Traditional Stores sell pizza and other authorized products and services at non-traditional locations like office buildings, shopping malls, stadiums, toll roads, airports, zoos, convenience stores and similar retail locations. Domino's Pizza Non-Traditional Stores ordinarily offer only carry-out service.

Domino's Pizza Traditional Stores and Domino's Pizza Non-Traditional Stores (collectively referred to as "Store" or "Stores" unless otherwise stated) operate under a unique system which includes special recipes and menu items; distinctive design and furnishings; standards and operating procedures; quality control procedures; training and advertising programs (the "System" or "Domino's Pizza System"). These Stores are also identified with certain trade names, service marks, trademarks, logos and emblems, including, the mark "Domino's Pizza" and other names and marks which we designate (the "Marks").

If you are acquiring a Domino's Pizza Traditional Store or a Domino's Pizza Non-Traditional Store selling pizza and other authorized products through delivery and/or carry-out service, you will sign our Traditional Store Franchise Agreement attached as Exhibit E ("Standard Franchise Agreement") or our Non-Traditional Store Franchise Agreement attached as Exhibit F ("Non-Traditional Store Franchise Agreement"), as applicable. Unless otherwise stated, the Standard Franchise Agreement and Non-Traditional Franchise Agreement are collectively referred to as "Franchise Agreement".

In appropriate circumstances, we may give you the right to open a limited number of Domino's Pizza Stores within a development area under our Development Agreement attached as Exhibit G ("Development Agreement"). You must sign our then current form of Franchise Agreement for Domino's Pizza Stores you open within your development area.

Experience

We or our predecessors or affiliates have operated Domino's Pizza Traditional Stores since 1960 and Domino's Pizza Non-Traditional Stores since 1990. As of December 31, 2023, there were 6,888 Domino's Pizza Traditional Stores (288 company-owned and 6,600 franchisee-owned). There were 21 Domino's Pizza Non-Traditional Stores, all of which are franchised. DPL granted franchises for Domino's Pizza Traditional Stores beginning in 1967 and granted franchises for

Domino's Pizza Non-Traditional Stores beginning in 1990. Company-owned stores are owned and operated by DPL.

Neither we nor any of our affiliates or predecessors have granted franchises in any other lines of business. Unless otherwise noted, the principal business address of our parents, affiliates and predecessors described above is or were 24 Frank Lloyd Wright Drive, Ann Arbor, Michigan 48105 or 30 Frank Lloyd Wright Drive, Ann Arbor, Michigan 48106.

Franchisee Qualifications

A franchise applicant must have been a Store manager or Store supervisor for at least 12 months to be eligible for a single Store franchise and must also have attended certain classes on operating a Store. These requirements apply whether he/she is building a new Store or buying a company-owned or franchised Store. We may from time to time accelerate or modify the basic eligibility and training requirements at our discretion based on your operational experience, business acumen and other factors, such as your agreement to open Stores in designated markets where few Domino's Pizza Stores are open. There are also minimum net worth and liquidity requirements depending on the number of Stores to be developed or purchased. We require that an individual owns 51% or more of the legal entity (the "Controlling Person"). The Controlling Person of a Domino's Pizza franchise may not have financial or operational involvement in another business outside of the Domino's Pizza System without our written approval which may be withheld in our sole judgment. There are additional factors that will be considered when reviewing a franchise application to the extent permissible under applicable law, including, but not limited to, the review of credit reports, criminal background history, reputation in the community, motor vehicle records, and, unless prohibited by applicable state law, the ability to speak the English language fluently.

Competition

Domino's Pizza Stores compete with national and regional "chains" and local businesses which sell similar products and offer carry-out or delivery services. The products Domino's Pizza Stores sell can also be prepared at home. However, we believe that customers purchase from Domino's Pizza Stores because of the timeliness of delivery and/or carry-out services, including our online ordering, the difficulty of duplicating the taste and texture of our products, convenience and the service we offer.

Government Regulation

There are no regulations specific to operating a Store. However, you must comply with all local, state and federal health and sanitation laws in operating your Store and other laws applicable to businesses generally, such as federal and state wage and hour and related laws, including laws that regulate mileage reimbursement paid to delivery drivers. DPL has been involved in litigation over whether the managers of Domino's Pizza stores are exempt employees under wage and hour laws. Certain franchisees pay store managers on a non-exempt basis. Whether store managers are classified as exempt or non-exempt employees under applicable law may affect store profitability because of overtime and other benefits due non-exempt employees. There may be local laws

regulating delivery service, including laws which may prohibit businesses offering delivery service or from refusing to provide delivery service to certain customers or areas. In addition, DPL entered into an agreement with the Department of Justice in June 2000 to ensure that decisions affecting delivery service will not be based on factors such as race, national origin, age or other characteristics protected by law. At the time, DPL adopted, on a system-wide basis, limited delivery service standards which applied to all company-owned and franchised Stores. DPL also adopted procedures for implementing these standards which are applicable to all Domino's company-owned Stores and provided to all franchisees as guidelines which franchisees may adopt to comply with these standards. These standards and procedures relate, in part, to the circumstances under which stores may limit delivery in certain areas for safety of store employees. All of these standards and procedures are applicable to all new and existing Domino's Pizza franchisees and company-owned Stores. There may be other laws which apply to your business. You should investigate these laws and their impact on your business.

Item 2: Business Experience

Manager and Chief Executive Officer of DPF and Manager and Chief Executive Officer of DPL: Russell Weiner

Mr. Weiner has served as Manager and Chief Executive Officer of DPF and Manager and Chief Executive Officer of DPL since May 2022. Mr. Weiner previously served as Chief Operating Officer and President, Domino's U.S. of DPL from July 2020 to April 2022. He served as Chief Operating Officer and President of the Americas of DPL from July 2018 to July 2020.

Manager of DPF: Linda Ciaramella

Ms. Ciaramella has served as a Manager of DPF since April 2022. Ms. Ciaramella is a Vice President of Lord Securities Corporation, a TMF-Group company based in New York, New York having been with the company from October 2001 to present.

Manager of DPF: Albert J. Fioravanti

Mr. Fioravanti has served as a Manager of DPF since May 2014. Mr. Fioravanti is Managing Director of Lord Securities Corporation, a TMF-Group company based in New York, New York having been with the company from December 1999 to present.

President, U.S. & Global Services of DPL: Joe Jordan

Mr. Jordan has served as President, U.S. & Global Services of DPL since May 2022. Mr. Jordan served as Executive Vice President – International in Amsterdam, The Netherlands from April 2018 to May 2022.

Executive Vice President, General Counsel & Corporate Secretary of DPF and DPL: Kevin S. Morris

Mr. Morris has served as Executive Vice President & General Counsel of DPL since January 2017. He was subsequently appointed and has served as Executive Vice President, General Counsel & Corporate Secretary of both DPF and DPL since November 2018.

Executive Vice President, Chief Financial Officer of DPF and DPL: Sandeep Reddy

Mr. Reddy has served as Executive Vice President, Chief Financial Officer of DPF and DPL since April 2022. Mr. Reddy served as Executive Vice President and Chief Financial Officer of Six Flags in Arlington, Texas from July 2020 to April 2022. He served as Chief Financial Officer of Guess? Inc. in Los Angeles, California from July 2013 to December 2019.

Executive Vice President, Chief Restaurant Officer of DPL: Frank Garrido

Mr. Garrido has served as Executive Vice President, Chief Restaurant Officer of DPL since March 2023. From March 2021 to March 2023, Mr. Garrido served as Executive Vice President – U.S. Operations and Support of DPL. He served as Senior Vice President – Team USA of DPL from June 2020 to March 2021. He has also served as Vice President – Franchise Operations – East of DPL in Atlanta, Georgia from January 2018 to June 2020.

Executive Vice President, Chief Supply Chain Officer of DPL: Cindy Headen

Ms. Headen has served as Executive Vice President, Chief Supply Chain Officer of DPL since March 2023. From August 2020 to March 2023, Ms. Headen served as Executive Vice President of Supply Chain Services of DPL. She served as Senior Vice President of Global Procurement and Supply Chain Operations of DPL from December 2018 to August 2020.

Executive Vice President, Chief Technology Officer of DPL: Kelly Garcia

Mr. Garcia has served as Executive Vice President, Chief Technology Officer of DPL since October 2020. He served as Senior Vice President and Chief Technology Officer of DPL from April 2019 to October 2020.

Senior Manager – Regulatory Affairs and Contracts of DPL: Angela Thompson

Ms. Thompson has served as Senior Manager – Regulatory Affairs and Contracts of DPL in Rosharon, Texas since May 2024. She served as Manager – Regulatory Affairs and Contracts of DPL from January 2019 to May 2024.

Senior Manager - Regulatory Affairs and Contracts of DPL: Colleen McCormick

Ms. McCormick has served as Senior Manager – Regulatory Affairs and Contracts of DPL since May 2024. She served as Manager – Regulatory Affairs and Contracts of DPL from October 2021 to May 2024. Ms. McCormick served as Team Leader – Regulatory Affairs and Contracts of DPL from January 2019 to October 2021.

Vice President – Franchise Business - Central of DPL: Mark Rudd

Mr. Rudd has served as Vice President – Franchise Business – Central of DPL in Boone, North Carolina since January 2018.

Vice President – Franchise Business – East of DPL: Erick Ortiz Sr.

Mr. Ortiz has served as Vice President – Franchise Business – East of DPL in Blackwood, New Jersey since March 2023. From August 2022 to March 2023, Mr. Ortiz served as Vice President – Franchise Business – Northeast of DPL in Blackwood, New Jersey. He served as Director – Franchise Business – Northeast of DPL in Blackwood, New Jersey from November 2017 to August 2022.

Vice President – Franchise Business – West of DPL: Mike Hardin

Mr. Hardin has served as Vice President – Franchise Business – West of DPL in Plano, Texas since December 2022. He served as Director – International Business – Canada, UK and Americas of DPI in Plano, Texas from May 2019 to December 2022.

Vice President – Global Development of DPL: Diane Porter

Ms. Porter has served as Vice President – Global Development of DPL since March 2023 in Apollo Beach, Florida. From August 2022 to March 2023, Ms. Porter served as Vice President – Franchise Business – Southeast of DPL in Apollo Beach, Florida. Ms. Porter served as Vice President – Franchise Business – East of DPL in Apollo Beach, Florida from June 2020 to August 2022. She served as Vice President – Corporate Operations from October 2014 to June 2020.

Senior Vice President – Franchise Relations and System Engagement of DPL: Debbie Sweeney

Ms. Sweeney has served as Senior Vice President – Franchise Relations and System Engagement of DPL since January 2020. Ms. Sweeney served as Vice President – Franchise Relations of DPL from July 2018 to January 2020.

Director – Franchise Business – Central of DPL: Brenda Seroka

Ms. Seroka has served as Director – Franchise Business – Central of DPL in Milwaukee, Wisconsin since August 2023. She served as a Franchise Business Consultant in

Milwaukee, Wisconsin from August 2022 to August 2023. Ms. Seroka served as a Franchise Development Consultant of DPL in Milwaukee, Wisconsin from November 2021 to August 2022. Ms. Seroka held the position of Franchise Business Consultant of DPL in Milwaukee, Wisconsin from October 2013 to November 2021.

Director – Franchise Business – Central of DPL: Eric Osterheldt

Mr. Osterheldt has served as Director – Franchise Business – Central of DPL since January 2022. He served as Director – International Business of DPL in Chesapeake, Virginia from June 2019 to January 2022.

Director – Franchise Business – Central of DPL: Jennifer Floyd

Ms. Floyd has served as Director – Franchise Business – Central of DPL in Austin, Texas since August 2022. She served as Director – Field Marketing – Central of DPL in Austin, Texas from January 2016 to July 2022.

Director – Franchise Business – East of DPL: Kristen Finnerty

Ms. Finnerty has served as Director – Franchise Business – East in Clarks Summit, Pennsylvania since March 2023. From August 2022 to March 2023, Ms. Finnerty served as Director – Franchise Business – Northeast of DPL in Clarks Summit, Pennsylvania. She served as Director – Field Marketing – East of DPL in Clarks Summit, Pennsylvania from October 2021 to August 2022. Ms. Finnerty held the position of Franchise Marketing Consultant of DPL in Clarks Summit, Pennsylvania from January 2012 to October 2021.

Director – Franchise Business – East of DPL: Suha Unal

Mr. Unal has served as Director – Franchise Business - East of DPL in Boston Massachusetts since March 2023. From October 2022 to March 2023, Mr. Unal served as Director – Franchise Business – Northeast of DPL in Boston, Massachusetts. He served as Director – International Business in Schiphol, The Netherlands from February 2019 to October 2022.

Director – Franchise Business – East of DPL: Casey Barile

Ms. Barile has served as Director – Franchise Business – East of DPL in Tampa, Florida since March 2023. From October 2021 to March 2023, Ms. Barile served as Director – Franchise Business – Southeast of DPL in Tampa, Florida. She served as Director – Field Marketing – East of DPL in Tampa, Florida from May 2019 to October 2021.

Director – Franchise Business – East of DPL: Katie Clough

Ms. Clough has served as Director – Franchise Business – East of DPL in Pensacola, Florida since March 2023. From August 2022 to March 2023, Ms. Clough served as Director – Franchise Business – Southeast of DPL in Pensacola, Florida. She served as

Director – Training – Team USA of DPL from March 2020 to August 2022. She served as Program Leader – US Franchise Operations of DPL from June 2018 to March 2020.

Director – Franchise Business – West of DPL: Brian O’Hearn

Mr. O’Hearn has served as Director – Franchise Business – West of DPL in San Antonio, Texas since July 2021. He served as Director – Corporate Operations of DPL in Las Vegas, Nevada from August 2018 to June 2021.

Director – Franchise Business – West of DPL: Chloe Sosenko

Ms. Sosenko has served as Director – Franchise Business – West of DPL in Los Angeles, California since August 2022. Ms. Sosenko served as Director – Franchise Development of DPL in Austin, Texas from April 2021 to August 2022. She was a Franchise Development Consultant of DPL in Austin, Texas from March 2020 to April 2021. Ms. Sosenko held the position of Franchise Business Consultant of DPL in Seattle, Washington from January 2018 to March 2020.

Director – Franchise Business – West of DPL: Jeffrey Musser, Jr.

Mr. Musser has served as Director – Franchise Business – West of DPL in Boise, Idaho since August 2023. Mr. Musser served as Director – Franchise Business – Central of DPL from February 2020 to August 2023. He served as Director – Global Operations, Standards, and Compliance of DPL from November 2018 to February 2020.

Senior Director – Global Development of DPL: Corey Pettyjohn

Mr. Pettyjohn has served as Senior Director – Global Development of DPL since December 2022. He served as Director – International Development of DPI in St. Louis, Missouri from January 2020 to November 2022. Mr. Pettyjohn held the position of Franchise Development Director – West of DPL in St. Louis, Missouri from January 2018 to December 2019.

Director – Franchise Development: Greg Moscetti

Mr. Moscetti has served as Director – Franchise Development of DPL since June 2023. He served as Senior Manager – Strategic Operations Initiatives of DPL from August 2022 to June 2023. Mr. Moscetti served as Manager – International Training of DPL from December 2018 to August 2022.

Item 3: Litigation

Unless otherwise noted, all references to Domino's Pizza, Inc., Domino's or DPI in the legal proceedings described below refer to DPL prior to the time it was converted to a limited liability company in 2000.

Pending Actions

RPM Pizza LLC v. Risk & Insurance Consultants, Inc., Applied Risk Solutions, LLC, Robert Kitchen, Jr., and Steve Molina v. Domino's Pizza, LLC, Domino's Pizza Franchising, LLC, and Joe Paweski (Case No. 1:23-CV-41 HSO-BWR, United States District Court for the Southern District of Mississippi). Franchisee RPM Pizza, LLC ("RPM") has a pending suit against its former insurance broker and affiliated entities and individuals, Risk & Insurance Consultants, Inc., Applied Risk Solutions, LLC, Robert Kitchen, Jr., and Steve Molina ("RIC, *et al.*") seeking to recoup its legal defense and costs incurred in an auto collision claim. As part of that suit, RIC, *et al.* filed a third-party complaint on May 31, 2023 against Domino's and its Director of Risk Management that includes the following claims: tortious interference with business relations; intentional/fraudulent/negligent misrepresentation; fraud; promissory estoppel; negligence; and attorneys' fees. The complaint also includes a libel claim against Domino's Director of Risk Management. RIC, *et al.* alleges that Domino's and its Director of Risk Management approved of the insurance program offered by RIC, *et al.* to Domino's franchisees, including RPM, but thereafter informed franchisees that their insurance was non-compliant with the terms of their franchise agreements. As a result, RIC, *et al.* contends that it was forced to transition franchisees, including RPM, to a replacement insurance carrier, allegedly resulting in significant financial loss to RIC, *et al.* RIC, *et al.* seek relief that includes financial reputational harm damages, indemnification, and attorneys' fees and costs. On July 21, 2023, Domino's filed a motion to dismiss all claims against it and its Director of Risk Management, which the court granted in part, dismissing all claims but RIC's implied indemnity claim on January 23, 2024. Domino's asked the court to reconsider its decision on that claim on January 30, 2024. On May 17, 2024, the Court granted Domino's motion for reconsideration and dismissed the implied indemnity claim with prejudice.

MAC Pizza Management Inc. v. Risk & Insurance Consultants, Inc., Applied Risk Solutions, LLC, Risk Services, LLC, Robert Kitchen, Jr., and Steve Molina v. Domino's Pizza, LLC, Domino's Pizza Franchising, LLC, and Joe Paweski (Case No. 23-A-126, Georgia State Court for Cobb County). Franchisee MAC Pizza Management Inc. ("MAC") has a pending suit against its former insurance broker and affiliated entities and individuals, Risk & Insurance Consultants, Inc., Applied Risk Solutions, LLC, Risk Services, LLC, Robert Kitchen, Jr., and Steve Molina ("RIC, *et al.*") seeking to recoup its legal defense and costs incurred in an auto collision claim. As part of that suit, RIC, *et al.* filed a third-party complaint on May 8, 2024 against Domino's and its Director of Risk Management asserting a single claim of implied indemnity based on the same allegations as the RPM matter. On June 12, 2024, Domino's filed a motion to dismiss the claim against it and its Director of Risk Management.

Additionally, DPL has been named as a defendant in several labor and employment lawsuits brought by employees of our franchisees, alleging that we are joint employers with our

franchisees. These lawsuits allege employment and wage and hour violations. We strongly disagree with the joint employment allegations and intend to vigorously defend these actions.

Concluded Actions

Domino's Pizza International Franchising Inc. v. Rutger-Jan Van Spaandonk, (Case No. 4:14-cv-11289-MAG-MJH (United States District Court for the Eastern District of Michigan) and Rutger-Jan Van Spaandonk, Rodney Ichikowitz, Keith Warren and International Food Service Concepts Limited v. Domino's Pizza International Franchising Inc., Taste Holdings Limited and Abraham Carel Viljoen, Case No. 17846/14 (High Court of South Africa, Gauteng Local Division, Johannesburg). In March 2014, Domino's Pizza International Franchising Inc. ("International") filed a lawsuit against Van Spaandonk, an individual with whom it had been negotiating regarding the possible execution of a Master Franchise Agreement for certain countries in Africa. International sought a declaration that no contract existed between it and Van Spaandonk, an injunction enjoining Van Spaandonk from interfering with Domino's dealings with its actual master franchisee, and damages for interference with those dealings. In May 2014, Van Spaandonk, Rodney Ichikowitz, Keith Warren and International Food Service Concepts Limited (collectively, the "Applicants") commenced a proceeding against International, Taste Holdings Limited (an affiliate of International's master franchisee for South Africa and certain other countries in Africa), and Abraham Carel Viljoen (collectively, the "Respondents") in the High Court of South Africa. The Applicants sought an order enjoining the Respondents from implementing a master franchise agreement in South Africa, Swaziland or Lesotho with Taste Holdings Limited, declaring that an agreement existed between them and International, and directing International to execute the Master Franchise Agreement, as well as costs incurred. In October of 2015, the parties entered into a Settlement Agreement under which International paid the Applicants \$400,000 and Applicants filed a Notice of Withdrawal with the High Court of South Africa and International voluntarily dismissed its Michigan lawsuit.

Actions Commenced Against Franchisees During Last Fiscal Year

No other actions are required to be disclosed in this Item.

Item 4: Bankruptcy

No bankruptcy is required to be disclosed in this Item.

Item 5: Initial Fees

Depending upon the type of Store to be developed, purchased or opened and whether you are participating in one of our incentive programs as discussed below and in Item 6, you will pay an initial franchise application processing fee ("Initial Fee") ranging from \$0 to \$10,000. The range of the Initial Fees paid to us during the year ending December 31, 2023, was from \$0 to

\$10,000. Our current policy for determining the amount of the Initial Fee is (subject to the terms of an incentive program):

- (1) If you are constructing a Store you will pay an Initial Fee of up to \$10,000.
- (2) If you are refranchising a closed Store you will pay an Initial Fee of up to \$10,000.
- (3) If you are purchasing an existing Store you will pay a transfer fee of \$1,500.

The Initial Fee is payable prior to us issuing the applicable agreement and is not refundable for any reason. Also, at our discretion, all or a portion of the fees described in (1), (2) and (3) above may be required to be paid when the initial franchise application is submitted for our review and approval, however, in practice, we generally do not bill and collect the Initial Fee until you are operating the Store. Additionally, at our discretion, this fee may be applied to the initial operational and classroom training of the individual who will own 51% or more of the equity and voting interest in the franchise. We may charge a reasonable training fee up to \$1,250 for these training programs or classes which you must complete to our satisfaction. We may waive all or a portion of the Initial Fee under incentive programs we implement from time to time to encourage system growth.

If you are developing a store under our new Store build incentive program, you may be required to pay us a reservation fee of \$25,000 if you fail to meet certain requirements of your Development Agreement. The reservation fee when paid is not refundable. Our store incentive programs are described in more detail in Item 6.

You must purchase inventory and supplies, equipment, fixtures, furnishings and signage to open your Store. DPD and approved vendors supply these items to franchisees. We estimate that these payments together with Initial Fee payments will range from \$88,950 to \$196,500 for a Domino's Pizza Traditional Store and \$69,950 to \$187,500 for a Domino's Pizza Non-Traditional Store, based upon the experience with store openings during the last year. See Item 7 for our current estimate of these costs. You must also make certain payments to DPD when you acquire the proprietary computer and point of sale system. See Items 6, 7 and 11.

Item 6: Other Fees

Development Agreement

There is no recurring or isolated fee or payment required under the Development Agreement. However: (i) if you do not provide a copy of the executed lease for a Store ninety (90) days after its respective Required Open By Date described in the Development Agreement; or (ii) you have not begun approved construction on a Store within one hundred and eighty (180) days of the Required Open By Date, you will be required to pay a \$25,000 fee ("Reservation Fee") to us for such Store required under the Development Agreement. Further, if you do not open all of your required new Stores under the Development Agreement, you must pay us the Reservation

Fee for each of the new Stores not opened. All Reservation Fee payments will be due within thirty (30) days written notice from us. Additionally, you must pay other required recurring or isolated fees under our then-current franchise agreement for the Stores you open in your development area. Except as noted, these fees are non-refundable and not collected on behalf of any third party.

Franchise Agreement

ITEM 6 TABLE
OTHER FEES

(1) Type of Fee ¹	(2) Amount	(3) Due Date	(4) Remarks
Royalty Fee	5.5% of Store's weekly Royalty Sales ²	Paid via electronic funds transfer by Thursday of each week on royalty sales for the week ending on the preceding Sunday.	Royalty Sales are the total receipts from all sales of pizza, beverages and other products or services authorized for sale at the Store or at any approved off-site location. ³
Advertising Fund	4% of Store's weekly Royalty Sales ^{2, 4} under the Franchise Agreement. Non-Traditional Stores may receive a partial credit or make a reduced contribution. ⁵	Same as Royalty Fee	See Item 11 for information concerning advertising and promotion.
Advertising Cooperatives	1-4% ⁶	Same as Royalty Fee	May be required to participate in local and regional advertising cooperatives. See Item 11
PULSE initial license fee	\$4,200	As invoiced	Paid to DPD.
Third Party Vendor Pulse Fees	\$1,357.04	As invoiced	Paid annually and is subject to annual adjustments by DPD. Fees are paid by DPD to third party vendors.

(1) Type of Fee¹	(2) Amount	(3) Due Date	(4) Remarks
Annual Software Enhancement Fee	\$743.10 per Store per year, after the first year ⁷	As invoiced	Covers cost of updates to Domino's PULSE core software. Fee for first year is included in initial cost. For further information about other fees and charges see footnotes #7 and #11 below.
Help Desk/Software Support Services	Currently \$44 per call and \$28 per chat	As invoiced	
Connectivity Fee	\$1,200 per year	As invoiced	Paid when you do not have high speed broadband connectivity where the service is available.
Flex Client Fee	\$150 per device	As invoiced	Paid to DPD (or a third party on behalf of DPD) if you use Google Chrome OS in connection with any of your devices. A new access fee will have to be paid when each device is replaced.
Annual Service Fee for Application Processing for store level positions	\$432.00 annually	As invoiced	Paid to DPD on a per store basis. ⁽⁸⁾
Technology Transaction Fee	\$0.355 per digital order	As invoiced	May be increased or decreased pursuant to the terms of the Online Ordering Franchise Services Agreement.
Credit Card Processing Fee	\$.0525 per transaction	As invoiced	Paid to an outside vendor and remitted to us by vendor to cover costs for credit card security and related costs

(1) Type of Fee¹	(2) Amount	(3) Due Date	(4) Remarks
Spanish Language Call Center Program Fee	\$3.00 per call	As invoiced	Each store using this service must make a monthly payment to DPD.
Inspections	Will vary under circumstances	As incurred	Includes all travel expenses, room and board and compensation of our employees.
Audit Expenses	Cost of audit, charges of employees, understatement plus 1.5% interest per month	10 days after receipt of final audit	Payable if understatement is greater than 2% or audited because you failed to submit reports.
Transfer	\$1,500	Before transfer	Payable when Franchise Agreement or the assets of the Store or any ownership interest is transferred.
Training Fees	Maximum – cannot exceed \$1,250 per session	Upon class registration	In addition to these training fees, we may require supplemental or additional training programs. You pay cost of additional or supplemental programs (not to exceed \$500) and other expenses.
Interest on Late Payments	Lesser of 1.5% per month or highest legal rate for open account business credit in the state Store	As incurred	Payable on all overdue amounts. 2% above the Libor rate for Alaska and Hawaii stores.
Charges for Testing and Evaluation	Will vary under circumstances	As incurred	See Item 8
Indemnification	Will vary under circumstances	As incurred	You must indemnify and hold us harmless if we are held liable from your Store's operations.

(1) Type of Fee¹	(2) Amount	(3) Due Date	(4) Remarks
Costs of Enforcement/ Non-compliance	Will vary under circumstances	As incurred	Reimburse us to enforce the Franchise Agreement. Under our Customer Care billing program, you will be charged \$20.00 for excessive calls we receive from your customers related to product and services concerns at your store. You will be charged only if the customer indicates they contacted the store and did not get resolution of his or her issue. For subsequent contacts to our Customer Care department by the customer, you will be charged \$30.00 per contact but only if they occur outside of a 5 day standard reply period.
Carryout Tracker Bundle	Currently \$321.73 but could increase if costs increase	As invoiced	Includes Flex Client and Cabling. Does not include staging, shipping, nor flex Client Fees
Server Bundle	Currently \$3,354.06 but could increase if costs increase	As invoiced	Includes pair of Servers and Display adapters. Does not include staging and shipping fees.
WAP & Meraki MX64 License	Currently \$280.00 per year but could increase if costs increase	As invoiced	Includes WAP & Meraki MX64 yearly licensing.
Meraki Router\WAP Hardware Bundle	Currently \$621.79 but could increase if costs increase	As invoiced	Includes router, WAP, POE injector, power cord. Licensing to use the hardware is not included.

(1) Type of Fee¹	(2) Amount	(3) Due Date	(4) Remarks
Lane 3600 Wired Customer Facing	\$644.02	As invoiced	Includes Lane 3600 CC reader, application, key injection, ethernet cable, power supply, and 3-year extended warranty.
Lane 3000 Wired EPP	\$496.34	As invoiced	Includes Lane2500 Wireless Hand Held Payment Terminal (Device, application, key injection, and 3-year warranty), Configuration of Device, Link 2500 Case, Link 2500 Charge Plate, Link 2500 Tether, Link Tether Adhesive, Lane 2500 Ingenico CC Reader, Sled Enclosure, Charge Plate, Tether, Tether Adhesive, Nut & Bolt, and Staging Fees.
Link 2500 WiFi EPP	\$599.03	As invoiced	Includes Lane3000 Wired Hand Held Payment Terminal (Device, application, key injection, ethernet cable, power supply, and 3-year warranty), Configuration of Device, Lane 3000 Ingenico CC Reader & Staging Fees.
Flex Client	Currently \$313.08 but could increase if costs increase	As Invoiced	Does not include staging, shipping, nor flex client fees.
Menuboard Client Bundle	Currently \$403.19 but could increase if costs increase	As Invoiced	Includes flex client, cabling, and cable management. Does not include staging, shipping, nor flex client fees.

- (1) All fees are imposed by and payable to us or our affiliates. All fees are non-refundable.
- (2) We may from time to time implement incentive programs to encourage system growth, improve store performance or accomplish other objectives designed to benefit the System. Under these incentive programs, we may reduce weekly royalty fees and/or reduce or eliminate advertising contributions payable by a participating franchisee for a period of time, including national and mandatory local advertising contributions (but not voluntary local co-op amounts approved by the local co-ops). We may impose limits on the amount of the incentives received under a particular program. The participating franchisee may also be asked to pay a reservation fee (which is currently \$25,000) for the right to develop one or more stores under an incentive program, which will ordinarily only be payable if the store or stores are not leased, constructed and/or opened within the time periods we specify. We reserve the right to modify or terminate these incentive programs in our sole discretion and to implement and grant these and other new or modified incentive programs to franchisees who we determine to be eligible for these programs under terms we deem appropriate.
- (3) Royalty Sales do not include sales and equivalent taxes and coupons and similar discounts we approve. For Non-Traditional Pizza Stores located in stadiums and airports, commissions payable to the stadium or airport authorities other than up-front fees are deducted from total receipts in computing Royalty Sales. Premium items or similar items are included in computing Royalty Sales unless these items have been sold at or below cost. Unless we otherwise specify, premium items or similar items do not include any food or beverage item.
- (4) The obligations of franchisees who signed Franchise Agreements before 2013 to contribute to the Advertising Fund may differ (see Item 11). The percentage currently charged for a Domino's Pizza Traditional Store is 4% of the weekly Royalty Sales.

You must pay up to 4% of the weekly Royalty Sales as an advertising contribution if you operate a Domino's Pizza Non-Traditional Store to an advertising fund. (see Item 11).

We may waive, in our sole discretion, the payment of a portion of the advertising fund contribution made by franchisees (i.e., reduce the percentage of the required contribution) for a period of time we designate based upon market conditions or other relevant factors.

We and our affiliates may set up a separate advertising fund for Domino's Pizza Non-Traditional Stores.

- (5) If you operate a Domino's Pizza Non-Traditional Store, we may rebate quarterly (or give you a credit for) up to 3½% of the 4% advertising contribution you pay for local advertising. We recommend you spend all credits in the calendar year in which they are given on local advertising expenditures.
- (6) If a cooperative exists and if 65% or more of the Stores in the cooperative agree or are contractually obligated to contribute a specified percentage of Royalty Sales, then you must

make the same percentage contribution to the cooperative. Each store we operate in the market contributes to advertising funds, and is entitled to vote, on the same basis as franchised stores. We have the right to require that you contribute no less than 2% of your weekly Royalty Sales to the cooperative. If there is no advertising cooperative or if the Stores have not agreed upon a percentage of Royalty Sales to contribute to the cooperative, franchisees are required to expend or contribute to the cooperative, as the case may be, an amount we specify up to and including 2% of the weekly royalty sales of your Store for local advertising. The maximum amount we can require that you contribute to the national advertising fund and local and regional advertising expenditures will be 9% of the weekly Royalty Sales of your Store.

- (7) You must acquire the Domino's PULSE point of sale computer system ("Domino's PULSE") if you are building a new Store or purchasing an existing Store that is not already equipped with Domino's PULSE. The specifications of the Domino's PULSE system are discussed below in more detail in Item 11. You must sign a Domino's PULSE Software License Agreement with our affiliate, DPD, in the form attached as Exhibit J, to use the Domino's PULSE software. The \$743.10 per year enhancement fee may be increased in subsequent years, however, it will not be increased by more than five percent (5%) in any given year, unless a higher amount is recommended by the Domino's Technology Advisory Board. In connection with the Domino's PULSE License Agreement you will also be required to sign a Participation Agreement with Microsoft which contains a right to use certain Microsoft software that is part of Domino's PULSE at a more favorable price than retail. You must acquire the Domino's PULSE hardware from a vendor approved by us. You will be required to enter into a Domino's Pizza Help Desk Services Agreement with DPL, in the form attached as Exhibit H, for Help Desk and Software Support Services for the entire term of the Domino's PULSE License Agreement. If we modify the computer and related technology requirements you may be required to incur costs to purchase, lease and/or license new or modified computer hardware and/or software and to obtain service and support. The cost to you of obtaining the software licenses, or additions, substitutions, replacements or modifications thereto, may not be fully amortizable over the term of the Franchise Agreement. The current cost estimate per store to acquire the hardware and software required, including payments due us, is \$15,000 to \$25,000 (other installation and service fees may apply) and is due as incurred. The difference between the high and low range is attributable in part to the number of order entry stations and additional Domino's PULSE related optional services. The current estimated cost per store for required maintenance and support contracts, third party software license fees, and upgrades or updates to the Domino's PULSE software should not exceed an average of \$7,000 annually. This estimated cost per store covers the annual enhancement fee due, system support services, third party license fees and software upgrades and maintenance including help desk and support services provided by a third party vendor. We may require that you continuously maintain high speed broadband connectivity, where available. All fees are imposed by and payable to DPD or our designated third party vendor. All fees are non-refundable.

We may develop or contract with third parties to develop centralized or technology based methods of taking, processing, routing, and delivering orders in addition to the methods

and technology we currently use or authorize (collectively "Additional Order Systems"). These may become mandatory at any time during the term of the Franchise Agreement and may require you to spend money to add or replace equipment, wiring, hardware and software; to pay licensing fees, support and maintenance fees, fees paid to third parties; to incur other costs, and to sign agreements with us and with third parties. To the extent these products and services are owned by us or provided to you by us, we may charge up front and/or ongoing fees that may be included as part of the Technology Transaction Fee. However, to the extent all the direct and indirect costs to develop, test and implement an Additional Order System are paid from other sources, then such up-front and ongoing fees charged by us would be intended only to cover our ongoing expenses, including direct costs and reasonable allocations. You currently must participate in an Additional Order System provided by a designated third-party vendor. Currently, no additional fees or costs are associated with the requirement to participate in such Additional Order System.

- (8) You will be required to accept and process applications for store-level positions through an online platform provided by SmartRecruiters. SmartRecruiters bills DPD annually and DPD then bills franchisees at cost for the use of the SmartRecruiters online platform every October. Currently, this amount is \$432.00 annually per Store. Currently, a call to GlobalCare for technical support with your SmartRecruiters online platform will result in a charge of \$44.

Item 7: Estimated Initial Investment

ITEM 7: TABLE
YOUR ESTIMATED INITIAL INVESTMENT

Domino's Pizza Traditional Store

(1) Type of Expenditure	(2) Amount	(3) Method of Payment	(4) When Due	(5) To Whom Payment is Made
Initial Fee ⁽¹⁾	\$0 to \$10,000	Lump Sum	When approved	Us
Leasehold Improvements ⁽²⁾	\$25,000 to \$350,000	Lump Sum	When completed	Landlord or other third party
Furniture, Fixtures and Equipment ⁽³⁾	\$81,000 to \$145,000	Lump Sum	Usually 30 days after invoice	DPD or other approved Supplier
Signage ⁽³⁾	\$5,200 to \$35,000	Lump Sum	50% when ordered 50% when shipped	Approved Suppliers
3 Month's Rent ⁽²⁾	\$3,000 to \$25,000	Lump Sum	When you sign the lease	Landlord

(1) Type of Expenditure	(2) Amount	(3) Method of Payment	(4) When Due	(5) To Whom Payment is Made
Security Deposit ⁽²⁾	\$1,000 to \$10,000	Lump Sum	When you sign the lease	Landlord
Opening Inventory and Supplies ⁽³⁾	\$2,750 to \$6,500	Lump Sum	Within 30 days of delivery	DPD or other approved Suppliers
Opening Advertising and Promotion ⁽⁴⁾	\$0 to \$3,000	Lump Sum	Proof of expenditures due 90 days after Store opening	Us
Training Expenses ⁽⁵⁾	\$1,000 to \$4,000	Lump Sum	When you register for class	Us
Insurance ⁽⁶⁾	\$25,000 to \$75,000	Lump Sum	Before Store opening/sale	Insurance Company
Miscellaneous Opening Costs ^(2, 7)	\$2,500 to \$7,000	N/A	N/A	Various Suppliers and Utilities
Additional Funds – 3 Months ⁽⁸⁾	\$10,000 to \$73,000	Unknown	As Incurred	Employees and various third parties
TOTAL ESTIMATED INITIAL INVESTMENT⁽⁹⁾	\$156,450 to \$743,500 ⁽¹⁰⁾			

Domino's Pizza Non-Traditional Store

(1) Type of Expenditure	(2) Amount	(3) Method of Payment	(4) When Due	(5) To Whom Payment is Made
Initial Fee ⁽¹⁾	\$0 to \$10,000	Lump Sum	When approved	Us
Leasehold Improvements ⁽²⁾	\$5,000 to \$350,000	Lump Sum	When completed	Landlord or other third party
Furniture, Fixtures and Equipment ⁽³⁾	\$62,000 to \$136,000	Lump Sum	Usually 30 days after invoice	DPD or other approved Supplier
Signage ⁽³⁾	\$5,200 to \$35,000	Lump Sum	50% when ordered 50% when shipped	Approved Suppliers

(1) Type of Expenditure	(2) Amount	(3) Method of Payment	(4) When Due	(5) To Whom Payment is Made
3 Month's Rent ⁽²⁾	\$3,000 to \$25,000	Lump Sum	When you sign the lease	Landlord
Security Deposit ⁽²⁾	\$1,000 to \$10,000	Lump Sum	When you sign the lease	Landlord
Opening Inventory and Supplies ⁽³⁾	\$2,750 to \$6,500	Lump Sum	Within 30 days of delivery	DPD or other approved Suppliers
Opening Advertising and Promotion ⁽⁴⁾	\$0 to \$3,000	Lump Sum	Proof of expenditures due 90 days after Store opening	Us
Training Expenses ⁽⁵⁾	\$1,000 to \$4,000	Lump Sum	When you register for class	Us
Insurance ⁽⁶⁾	\$15,000 to \$50,000	Lump Sum	Before store opening/sale	Insurance Company
Miscellaneous Opening Costs ^(2, 7)	\$2,500 to \$7,000	N/A	N/A	Various Suppliers and Utilities
Additional Funds - 3 Months ⁽⁸⁾	\$10,000 to \$73,000	Unknown	As incurred	Employees and various third parties
TOTAL ESTIMATED INITIAL INVESTMENT⁽⁹⁾	\$107,450 to \$709,500 ⁽¹⁰⁾			

Explanatory Notes.

- (1) The Initial Fee for single Stores ranges from \$0 up to \$10,000.
- (2) You must lease an appropriate site, subject to our approval of the lease prior to your execution of the lease. Generally, the leases are for 5 years with an option to renew for 5 years. The term and renewal of leases for Domino's Pizza Non-Traditional Stores will be subject to negotiation but may be three (3) years or less subject to renewals or extensions by the parties. The amounts specified for leasehold improvements and security deposits on a lease and rent are based on our business experience. These costs depend on the size, condition, and location of the leased premises, and the costs the landlord assumes.

- (3) See Footnote (7) in Item 6 and Items 8 and 11 for information about the Domino's PULSE hardware and other technology requirements, including Additional Order Systems. Other than as described in Items 7 and 8, you may purchase or lease original equipment and supplies, signs and opening inventory meeting our standards from any approved source, including DPD. DPD is in the process of transitioning equipment and supply ordering to a third-party supplier, Clark Associates, and anticipate the transition being completed by August 30, 2024. The purchase or lease payments are made to either DPD or other suppliers. We do not require you to purchase or lease delivery cars and therefore we do not include these costs in this Item.
- (4) This amount is for opening advertising and promotion and does not include Advertising Fund or cooperative contributions.
- (5) Training expenses include fees for training materials for each session required for all new employees, manager candidates, managers and prospective franchisees. The travel expenses are the participant's responsibility.
- (6) We estimate that annual insurance premiums for a traditional Domino's Pizza Traditional Store to range from \$25,000 to \$75,000; and from \$15,000 to \$50,000 for a Domino's Pizza Non-Traditional. However, this cost may be significantly higher depending on the state coverage requirements, store location and your loss history.
- (7) The Miscellaneous Opening Costs are our best estimate of the costs and deposits for and installation of telephones, connectivity, internet, deposits for gas, electricity and related items. These are paid as incurred to various utilities and suppliers.
- (8) This item estimates your initial startup expenses for 3 months. This item does not include ongoing inventory purchases, royalty or advertising payments or the cost of any financing interest or amount of debt service obligation. These figures are estimates and we cannot guarantee that you will not have additional expenses starting the business. Your costs will depend on the following factors: how much you follow our methods and procedures; your management skill, experience and business acumen; local economic conditions; the local market for your products and services; the prevailing wage rate; competition; and the sales level reached during the initial period.
- (9) We relied on over 50 years of our affiliates and predecessors business experience to compile these estimates. You should review these figures carefully with a business advisor before making any decision to purchase the franchise.
- (10) From time to time we sell company-owned stores to franchisees. The form of agreement DPL currently use to sell the assets of company owned stores to franchisees is attached as Exhibit I (the "Sale of Assets Agreement"). The purchase price of the store will vary and may be more or less than the amounts set forth in the tables. Of all the sales of company owned stores in 2023, zero exceeded the upper range of the Total Estimated Initial Investment in the Item 7 Table.

Development Agreement

An initial investment is not required when you sign the Development Agreement. However, an initial investment is required each time a Store is opened within your development area.

Item 8: Restrictions on Sources of Products and Services

We will provide you with specifications for pizza, other authorized food and beverage preparation, dispensing, storage and display equipment, delivery and related motor vehicles, other equipment, fixtures, furniture, exterior and interior signs and decorating that we require you to use or install in the Store. We may specify brands, types or models for any of these items. You may purchase items meeting our specifications from any source unless we designate an approved source or sources for any of these items. If you propose to purchase or lease items not previously approved by us as meeting our specifications or from a vendor not approved by us, you must first notify us and we may require submission of sufficient specifications, photographs, drawings and/or other information and samples to determine whether any such item or supplier meets our specifications or our approved vendor criteria. We will advise you within a reasonable time whether any proposed item or vendor meets our specifications or our approved vendor criteria. You must use only such items that meet our specifications in the operation of the Store and to purchase them from approved vendors, if we so require. We or our affiliates or an approved vendor may be the only source for some of these items and we may otherwise limit the number of approved vendors. We reserve the right to charge you for our reasonable expenses in testing and/or evaluating any proposed item or vendor submitted by you.

Unless otherwise agreed to by us in writing, if the property which the Store is located is not owned by you, you must maintain a lease for the site of the Store (including the lease for the site of the commissary, if any, which has been approved by us to be operated by you) which must contain such terms as we specify from time to time for all leases of a similar type. Each original lease, renewal leases and lease addenda and modification of any type must be submitted to us prior to execution for our examination and approval that it contains the terms we require in all leases. You must provide us with a copy of the executed lease, any renewal lease, and any addenda and modification or other instrument or agreement governing occupancy of the premises within thirty (30) days after execution by you and the landlord. Attached as Exhibit L is a Rider to Lease which contains the terms we currently require. This Rider must be signed at the time the lease is executed.

You must use in the development and operation of the Store the management system and computer hardware and software and related technology designated by us, including without limitation, features such as high-speed broadband connectivity, high-speed broadband monitoring, online ordering, methods and means of encryption and access to our network resources, and other internet based technology and peripheral devices that we specify from time to time (the "Brand Technology"). We may modify all aspects and the components of the Brand Technology from time to time. As part of the Brand Technology, we may require you to obtain computer hardware and/or software we specify from a single vendor designated by us and we or our affiliates may be

the sole supplier of all or any part of the Brand Technology. You may use only such items and services as we specify in connection with the Brand Technology. We may require that you enter into a license exclusively with us or our affiliates to use proprietary software developed by or for us. You may also be required to enter into agreements with others for use of third party software incorporated or used in connection with the Brand Technology. Our modification of such specifications or components for the Brand Technology may require you to incur costs to purchase, lease and/or license new or modified computer hardware and/or software and to obtain service and support for the Brand Technology during the term of the Franchise Agreement. The cost to you of obtaining the Brand Technology (including software licenses) (or additions, substitutions, replacements or modifications thereto) may not be fully amortizable over the remaining term of the Franchise Agreement. You must incur such costs in connection with obtaining the computer hardware and software comprising the Brand Technology (or additions, substitutions, replacements or modifications to the Brand Technology), provided you will not be required to make aggregate expenditures for any additions, substitutions, replacements or modifications to the Brand Technology in excess of one and one half percent (1 ½ %) of the Royalty Sales of the Store from the date of its opening to the date we require you to make any additions, substitutions, replacements or modifications to the Brand Technology not to exceed the ten (10) year period prior to the date we require you to make any additions, substitutions, replacements or modifications to the Brand Technology or, except in connection with a renewal of the franchise, to make any additions, substitutions, replacements or modifications to the Brand Technology during the last twelve (12) months of the initial term of the franchise. We have the right to charge reasonable fees for software or systems modifications and enhancements specifically made for us that are licensed to you and other maintenance and support services that we or our affiliates furnish to you related to the Brand Technology. You may also incur charges from third parties who render services or provide products that we require you to purchase or use. We shall have independent access to data on your Brand Technology, including sales figures. There are no contractual limitations on our right to access this information and data.

Our affiliate, DPD, is the only approved supplier of the Domino's PULSE software used in Domino's Pizza stores (see Item 11 for additional information about Domino's PULSE). Any Domino's PULSE hardware and/or agreement for support and maintenance of the computer hardware must be acquired through a vendor or supplier approved by us. Currently Getronics is the approved vendor for the purchase of new hardware. DPL provides help desk services. There are currently no third party vendors for help desk services. Getronics is the approved hardware warranty and service vendor. At the time you acquire the Domino's PULSE system, you will also be required to enter into an agreement for help desk support and maintenance with DPL during the term of the Domino's PULSE Software License Agreement. We reserve the right to offer help desk and support services and to charge a fee for these services. In connection with the Domino's PULSE License Agreement you will also be required to sign a Participation Agreement with Microsoft which is a sublicense of certain Microsoft software that is part of Domino's PULSE. The Microsoft Participation Agreement is Attachment C to the Domino's PULSE Software License Agreement (Please see Exhibit J to this disclosure document). Help desk and support services providers may also require you to sign an agreement for their services.

You will be required to enter into a Domino's Pizza Online Ordering Franchisee Services Agreement with DPL, the form attached as Exhibit P, for online ordering services. You will be

responsible for the fees and charges associated with your use of online ordering and the requisite internet usage and connections, including the fees charged by the service provider. Currently the fees are \$0.355 per transaction and are subject to increase each year.

As noted in Items 6 and 7, we may develop or contract with third parties to develop Additional Order Systems. These may become mandatory at any time during the term of the Franchise Agreement and may require you to spend money to add or replace equipment, wiring, hardware and software; to pay licensing fees, support and maintenance fees, fees paid to third parties; to incur other costs, and to sign agreements with third parties. You must also comply with all standards, operations and procedures related to e-mail capabilities of the Store and other electronic communication methods (including high-speed broadband connectivity, high-speed broadband monitoring, and methods and means of encryption and access to our network resources) and devices to facilitate communication with us or our offices, including the exchange of information between the Store and us. You currently must participate in an Additional Order System provided by a designated third-party vendor.

As previously noted in Item 6, you will be required to accept and process applications for store-level positions through an online platform provided by SmartRecruiters under a contractual agreement with SmartRecruiters. SmartRecruiters bills DPD for the use of the SmartRecruiters online platform and you must make annual payments every October to DPD to utilize this service. Currently, this amount is \$432 annually per Store. You will have full discretion to determine and control the contents of the online platform and are solely responsible for making hiring and other employment decisions for your store(s). You are solely responsible for ensuring your compliance with applicable laws, rules, regulations, and ordinances. You may accept applications for store-level positions through other methods as an accommodation of an applicant's disability or as otherwise required by applicable laws, rules, regulations, or ordinances. We will not have access to the content (including applicant information) you maintain on this online platform.

You are required to participate in the Domino's Pizza Gift Card Program and obtain and use Gift Cards, transaction processors and related services, from vendors approved by us and pay the fees associated with the Gift Card Program. The Gift Card is an electronic cash card available for purchase and redemption at Domino's Pizza stores and online, for use as a payment method for food and beverage purchases. Customers may also increase, replenish or restore balances available on the Gift Card at any Domino's Pizza store if we so designate. We will debit or credit your bank account for the net amount of Gift Card purchases / balance increases and redemption transactions. The funds collected are not and will not be the asset of any franchisee. You must obtain and use gift cards and transaction processors, including internet or other connections, from vendors designated by us. You will also be required to use the designated transaction processor which at the present time is Ceridian Stored Value Solutions. Cards are issued by CARDCO CXXV, Inc. and distributed by Domino's GC Inc.

DPL's Quality Assurance Department maintains, on our behalf, a listing of approved products and suppliers. This is the only list franchisees may use to verify approval status. If you wish to purchase or lease items we have not approved, you may propose a request through your Franchise Business Consultant. Along with the request, you must include any photographs, drawings, information source of items, samples or any materials or information necessary to

adequately describe the request. You will be advised within a reasonable time (not to exceed 180 days) whether any item meets the criteria to forward to the Standards Committee for further consideration and final approval, including any additional requirements which may be imposed by the Standards Committee as a condition for the proposed supplier to receive final approval. We may charge you for reasonable expenses that we or our affiliates incur in evaluating any proposed item. The number of suppliers of any item may depend on the availability of these items and whether suppliers manufacture items meeting our specifications.

You must purchase food ingredients, beverage products, cooking, packaging and cleaning materials, other products, utensils, uniforms, menus, forms, and other supplies and materials used in the Store that meet our standards. You must use paper and plastic products imprinted with the Marks that we establish. We may require you to purchase the ingredients, supplies and materials used exclusively from us, our affiliates or from approved suppliers or distributors. We or our affiliates may examine the facilities of any approved supplier or distributor, including the commissary, if any, you operate and test the ingredients, materials or supplies. We or our affiliates may charge fees for evaluating proposed and approved suppliers or distributors and inspecting commissary operations. We may impose limitations on the number of approved suppliers or distributors of any product or service. As noted, we or our affiliates may be the exclusive supplier of certain products. A list of approved suppliers will be made available to you. Approval of a supplier or distributor may be conditioned on delivery schedule and service, among other things. In addition, your ability to purchase from other suppliers, including those who sell to us or our affiliates, depends on factors including suppliers' willingness to sell to you and the availability of various products and services that meet our standards. To protect the confidentiality of our proprietary products, including sauce, dough and cheese, we may limit the sources of supply of these products. Any supplier which has access to customer data or confidential or proprietary information shall be required to sign our then-current form of our Rider to Services Agreement attached as Exhibit S (the "Domino's Rider to Services Agreement").

We and our affiliates have established business relationships with a group of nationally recognized vendors who have agreed to provide goods and services at discounted prices to our franchise system as part of a program known as the "Pie Perks Program". The discounts are based in part on our relationship with these vendors and our ability to purchase goods and services from them in larger quantities. The program is designed to help reduce expenses on various items and services, including, but not limited to, supplies, telecommunications services, accounting and payroll services, repairs and maintenance. You may, at your option, participate in this program and take advantage of the discounts without additional cost to you. Other than the same discounts that are available to you under the program, neither we nor our affiliates receive any revenue from the vendors as a result of this program.

DPL entered into a beverage marketing agreement with The Coca-Cola Company with an effective date of January 1, 2019 for a term ending the later of December 31, 2023 or until such time as certain volume commitments are reached which entitles franchised and company-owned locations to qualify for volume incentive funding based upon the number of cases of Coca-Cola beverage products purchased from participating Coca-Cola bottlers. The aforementioned agreement did not meet the certain volume commitments as of the expiration date of December 31, 2023, and remains in effect until December 31, 2024. The Coca-Cola Company has also agreed

to pay DPL certain fixed funding along with variable funds for national marketing, media programs and promotions under the terms of the beverage marketing agreement. Coca-Cola beverages has been designated as the company standard for beverages for sale at Domino's Pizza Stores. Although franchisees can only offer Coca-Cola beverages at their Domino's Pizza Stores, they can purchase these products from any supplier or retailer, including participating Coca-Cola bottlers.

DPLLC, DNAF and DP IP Holder entered into a co-promotion agreement with Dairy Management Inc., a company dedicated to promoting the dairy industry and dairy products on behalf of dairy products, for a term commencing on January 1, 2022 through December 31, 2023, which entitles DNAF and DPL to receive payments to fund dairy-centric initiatives.

DPLLC entered into a marketing agreement with Paypal, Inc. with an effective date of November 1, 2023 for a term ending no later than December 31, 2024 to establish promotional campaigns in which customers can get discounts on Domino's when ordering with VenmoPay on Domino's eCommerce channels. Venmo has agreed to fund implementation costs for VenmoPay, as well as reimbursement for promotional offers redeemed by Domino's customers tied to VenmoPay within marketing funding limits established for 2023 and 2024. Additionally, under agreements entered into with designated third-party vendors in 2023 and 2024, DPL is entitled to receive rebates and/or other payments on account of franchisee's participation in the Additional Order System and franchisees' purchases of equipment, supplies, and branded merchandise from third-party vendors.

In 2023, DNAF received an estimated \$23,058,116.96, and DPL received an estimated \$4,380,000.00 under the programs described above. Except for these payments, neither we nor our affiliates receive any payments or credits from suppliers for the purchase of products by or for the benefit of franchisees, although we and our affiliates reserve the right to do so.

DPD supplies certain of these products and items to franchisees. DPD will derive revenue from the sale of these items by selling them above cost. DPD offers an optional profit sharing plan for franchisees. Prior to the Securitization Transaction, Domino's Pizza Distribution entered into these profit sharing arrangements with franchisees. These were assigned to DPD as part of the Securitization Transaction. Under this plan, franchisees must purchase their required food products from DPD for a period of 10 years in exchange for a share of the profits of the DPD centers in the United States servicing Domino's Stores nationally. Franchisees can terminate their participation in the plan by giving 1 year notice or immediately refunding profit sharing payments for the previous year or if DPD breaches, and does not cure, a material obligation or commitment under the plan.

DPD is an approved supplier of fresh dough balls for our original screen product and fresh pan pizza and is the supplier of a parbaked and then frozen shell for our thin crust pizza. If we or our designee give written approval for you to operate a commissary, you can make your own dough if it complies with our food safety, product and quality standards. There are currently no third-party suppliers of fresh or pan pizza dough balls or parbaked and then frozen shells for our thin crust pizza. Commissary operators will be required to purchase a pre-mix package from approved suppliers to produce these different types of dough. DPD is an approved supplier of pre-mix for

our screen and pan dough products. In addition, there are three approved manufacturers of premix from whom franchisees can purchase directly.

For the benefit of the System, we and/or our affiliates have and will continue to test and develop other dough products. We have approved the original screen product, pan pizza, a thin crust and a frozen par-baked Gluten Free crust for Domino's Pizza Stores. We have also approved a frozen par-baked crust for a limited number of non-traditional Domino's Pizza Stores. Currently, DPD is the only approved supplier of thin crust to our franchisees. In addition, there is 1 approved supplier of Gluten Free crust.

When we and/or our affiliates periodically test new products in Stores, we may require you to purchase these products exclusively from DPD or otherwise limit the distribution and use of these products.

We or our affiliates may from time to time offer or make available other services or products to franchisees, such as online ordering and gift cards. We or our affiliates may derive revenue from the sale of these services and products to franchisees or from the participation by franchisees in these programs.

You must maintain at your sole expense: (a) property insurance on a replacement cost basis at minimum limits based on the total value of your assets (all risk coverage); (b) general liability insurance (including coverage for personal injury, products and contractual liability); (c) automobile liability insurance (including owned automobiles, titled or leased in your name and the name of your owners and used at any time, whether principally or occasionally in the business, hired and non-owned coverage); and (d) worker's compensation insurance (in your name) as required by law. If no worker's compensation law exists, then you must participate in comparable insurance we require. If you or your owners do not use a vehicle owned or leased in your name or the name of any of your owners in the business, you must provide written evidence, satisfactory to us. We require you to have minimum limits of \$1,500,000 per occurrence for general liability insurance and for automobile liability insurance. If your state recognizes and permits self-insurer programs, your participation in a program will satisfy our requirements under Section 15.7(d) of the Franchise Agreement. If deductible plans are approved and used in your state, you may purchase this coverage subject to the requirements of your insurance carrier. An insurance carrier rated B⁺ or better by Alfred M. Best & Company, Inc. or meeting such other criteria we may establish from time to time must issue all insurance policies, except workers' compensation insurance. All liability insurance policies must name us and any subsidiaries and affiliates that we designate, as additional insureds and provide us with 30 days prior written notice of termination, expiration, cancellation or modification of any policy. The terms and conditions of all such policies, including the amount of any deductibles, will be consistent with the requirements prescribed from time to time by us. We may also reasonably increase the minimum liability "limit" protection requirement annually and modify the insurance requirements. You must provide us annually with satisfactory evidence of the renewal or extension of each insurance policy or any modifications to any insurance policy that must describe the applicable deductibles for each policy.

If you fail to carry any insurance coverage we require or to furnish satisfactory evidence of the insurance, we or our designee may obtain insurance coverage for you and you must promptly

sign any documents required and pay to us on demand amounts we incur. Your obligation to maintain the required insurance is not limited by insurance we maintain. Your failure to carry required insurance at our specified limits could result in default.

Depending on whether you purchase certain products from us or our affiliates, we could provide you with approximately 90% of your total purchases in establishing your Store and generally between 25%-40% of your total ongoing operating expenses for your Store. Total operating expenses include all of your ongoing expenses in operating a Store, including rent and labor. In the fiscal year that ended December 31, 2023, DPD’s revenue from the sale of these items to all franchisees was \$2.5 billion or 55.8% of DPL’s total revenues of \$4.5 billion. In the fiscal year that ended December 31, 2023, DPL also collected revenue of \$134.3 million for online ordering fees, technology fees, credit card fees, help desk fees, and other miscellaneous fees and expenses from franchisees representing 3% of DPL’s total revenues of \$4.5 billion.

There are no approved suppliers in which any of our officers has an ownership interest.

Item 9: Franchisee’s Obligations

ITEM 9 TABLE:

FRANCHISEE’S OBLIGATIONS

This table lists your principal obligations under the franchise and other agreements. It will help you find more detailed information about your obligations in these agreements and in other items of this disclosure document.

Unless otherwise noted, the Standard Franchise Agreement and Non-Traditional Franchise Agreement are referred to as the “Franchise Agreement”. Section references are the same in each one of these agreements.

Obligation	Section in Agreement	Disclosure Document Item
(a) Site selection and acquisition/lease	Section 7.4 of the Franchise Agreement, and Section 5 of the Development Agreement	Items 7 and 11
(b) Pre-opening purchases/leases	Sections 8.1, 8.2 and 15.9 of the Franchise Agreement	Items 6, 7, 8 and 11
(c) Site development and other pre-opening requirements	Section 8 of the Franchise Agreement and Section 4 of the Development Agreement	Items 6, 7 and 11
(d) Initial and ongoing training	Sections 10 and 15.9 of the Franchise Agreement	Items 6, 7 and 11
(e) Opening	Section 8.3 of the Franchise Agreement	Item 11

Obligation	Section in Agreement	Disclosure Document Item
(f) Fees	Sections 5, 6 and 15.9 of the Franchise Agreement and Section 8 of the Development Agreement	Items 5, 6, 7 and 11
(g) Compliance with standards and policies/Operations Manual	Section 15 of the Franchise Agreement	Item 11
(h) Trademarks and proprietary information	Sections 16 and 20.4 of the Franchise Agreement and Section 10 of Development Agreement	Items 13 and 14
(i) Restrictions on products/services offered	Sections 12.1, 12.2 and 15.9 of the Franchise Agreement	Items 8, 11 and 16
(j) Warranty and customer service requirements	Sections 12.2 and 15.1 of the Franchise Agreement	Item 8
(k) Territorial development and sales quotas	Sections 2.1 and 4 of the Franchise Agreement and 4 of the Development Agreement	Item 12
(l) On-going product/service purchases	Sections 12 and 15.9 of the Franchise Agreement	Items 8 and 11
(m) Maintenance, appearance and remodeling requirements	Sections 9 and 15.9 of the Franchise Agreement	Items 8 and 11
(n) Insurance	Section 15.7 of the Franchise Agreement	Items 7 and 8
(o) Advertising	Section 13 of the Franchise Agreement	Items 6, 7 and 11
(p) Indemnification	Sections 16.3 and 22.3 of the Franchise Agreement	Item 6
(q) Owner's participation/management/staffing	Section 15.6 of the Franchise Agreement and Section 7 of Development Agreement	Items 11 and 15
(r) Records/reports/audits	Section 14 of the Franchise Agreement	Item 11
(s) Inspections	Section 17 of the Franchise Agreement	Item 6
(t) Transfer	Section 21 of the Franchise Agreement and Section 13 of Development Agreement	Item 17
(u) Renewal	Section 3 of the Franchise Agreement	Item 17
(v) Post-termination obligations	Section 18.3 of the Franchise Agreement	Item 17

Obligation	Section in Agreement	Disclosure Document Item
(w) Non-competition covenants	Section 20 of the Franchise Agreement	Item 17
(x) Dispute resolution	Section 22 of the Franchise Agreement	Item 17

Item 10: Financing

We do not offer direct or indirect financing. We do not guarantee your note, lease or obligation.

Item 11: Franchisor’s Assistance, Advertising, Computer Systems, and Training

As noted in Item 1, we have entered into a servicing agreement with DPL for the provision of support and services to franchisees. We remain, however, responsible for all of the support and services required under the various agreements described below.

Development Agreement

Except as listed below, we need not provide any assistance to you under the Development Agreement.

Before you open your business we will:

- (1) Grant you the right to open a limited number of Stores within a development area. (Development Agreement – Section 1 and Section 4);
- (2) Not unreasonably withhold approval of a site that meets our requirements. (Development Agreement – Section 5); and
- (3) Deliver our then-current form of Franchise Agreement to you. (Development Agreement – Section 6) However, our approval of a location depends on whether we determine that:
 - (a) you and your owners have the financial capacity and necessary skills and experience to develop and operate the Store based upon criteria established by us from time to time;
 - (b) the site proposed is within the Development Area and suitable site for a Domino's Pizza Store based upon criteria established by us from time to time;

- (c) you and your owners comply with your Development Agreement and all other Domino's Pizza Franchise Agreements. (Development Agreement - Section 5); and
- (d) you and your owners have furnished all information we may reasonably require in evaluating your application.

Franchise Agreement

Except as listed below, we need not provide any assistance to you under the Franchise Agreement.

Before you open the Store, we will:

- (1) Approve the lease or other document for occupancy of the premises. (Standard Franchise Agreement - Section 7.4; Non-Traditional Store Franchise Agreement - Section 7.4)
- (2) Approve site plan and any modifications to our basic plans and specifications for the Store (Franchise Agreement – Section 8.1);
- (3) Provide you with standards for authorized food and beverage preparation, storage and display equipment, motor vehicles, other equipment, fixtures, furniture, signs and decorating required. (Franchise Agreement – Section 8.2);
- (4) Offer certain training programs which you must enroll in and complete before operating the Store. (Franchise Agreement – Section 10.1); and
- (5) Provide you with reasonable operating assistance and provide general guidance. (Franchise Agreement – Section 11.1).

During your operation of the Store, we will:

- (1) Provide you with information on operating the Store. Operating assistance will include:
 - (a) methods of authorized food and beverage preparation, packaging and sale; and
 - (b) administrative, accounting, inventory control and general operating procedures. (Franchise Agreement – Section 11.1);
- (2) Advise you of operating problems from your reports or our inspections. (Franchise Agreement – Section 11.2);

- (3) From time to time formulate, develop, produce and conduct advertising and promotional programs in the form and media as we determine to be most effective as described below. (Franchise Agreement – Section 13.1);
- (4) Establish maximum, minimum, or other pricing requirements you may charge for products and services to the fullest extent permitted by law. (Franchise Agreement – Section 15.3);
- (5) Offer certain additional training programs which we may require you to attend as more fully described below. (Franchise Agreement – Section 10.3);
- (6) Not unreasonably withhold approval to a proposed transfer if all requirements are met. (Franchise Agreement – Section 21.4);
- (7) Prescribe the Brand Technology or Computer Systems as described below (Franchise Agreement – Section 15.9); and
- (8) Loan to you 1 or more manual or electronic copies of an operating manual or operational bulletins or similar materials containing mandatory and suggested specifications, standards and operating procedures and rules and information about your other obligations under the Franchise Agreement and the operation of the Store (the "Operating Manual"). (Franchise Agreement – Section 15.4). Exhibit N contains a copy of the table of contents of the Operating Standards as of July 2024 which contains 26 pages and the Product Standards as of April 2024 which contains 43 pages.

Advertising and Promotion

We have the authority to determine the composition of all geographic territories and market areas for the advertising and promotion programs. All formulation, development and production costs of advertising and promotion (including the proportionate compensation of our employees for advertising functions) are paid from a separate fund administered by the DNAF.

Item 6 describes your Advertising Fund contribution. Your contribution will depend on the Standard Franchise Agreement or Non-Traditional Store Franchise Agreement. The advertising fee for a Domino's Pizza Traditional Store is currently 4% of Royalty Sales of the Store. You must pay up to 4% of the weekly Royalty Sales as an advertising contribution if you operate a Domino's Pizza Non-Traditional Store to an advertising fund. We may waive, in our sole discretion, the payment of a portion of the advertising fund contribution made by franchisees (i.e., reduce the percentage of the required contribution) for a period of time we designate based upon market conditions or other relevant factors. A Domino's Non-Traditional Store does not contribute to regional or local cooperatives. It is therefore not affected by any advertising fund roll-up. All Stores owned by DPL contribute to the advertising and promotions programs on at least the same basis as the majority of domestic franchisees in the Domino's Pizza System. Vendors and suppliers may contribute to the Advertising Fund. We or our

affiliates may hire advertising source(s) with money from the Advertising Fund to develop, produce and conduct the advertising and promotion programs.

The Advertising Fund is intended to maximize recognition of the Marks and patronage of the Stores. We do not have to ensure that Advertising Fund expenditures are proportionate or equivalent to your contributions for the market area of the Store or that the Store will benefit directly or in proportion from the advertising.

During the fiscal year that ended December 31, 2023, the Advertising Fund spent a total of \$575,573,463.74; 5.31% was spent on production; 88.52% was spent on media placement; 3.06% was spent on administrative expenses; and 3.11% was spent on other items (research, talent, public relations and brand promotions). The Advertising Fund does not spend all advertising funds in the same fiscal year that they are accrued in. The funds that are not used in the same fiscal year are used in future years. An annual statement of monies collected, and costs incurred by the Advertising Fund are available on an annual basis. The Advertising Fund did not spend money to solicit new franchisees. The Advertising Fund may place advertising in any media. The coverage is typically national in nature. Advertising is developed by our in-house marketing department and national advertising agencies and other advertising partners.

We or our affiliates may also spend or advance our own funds for promotional materials and the conduct of advertising programs for the benefit of the Domino's System.

The Domino's Marketing Advisory Council ("DMAC") provides advice on marketing and advertising programs. The DMAC whose membership is currently selected by DPL on behalf of the Domino's System, currently has 8 franchisees and 2 or more corporate representatives. Two of the 8 franchisees on DMAC are selected by DPL to participate on the DNAF board as well. We (or DPL on behalf of the Domino's System) may change or dissolve the DMAC at any time.

We may require you to participate in local and regional advertising cooperatives for advertising and promotional programs administered by us or by other franchisees of the System. In addition to the national advertising contribution (Standard Franchise Agreement – Section 13.1; Non-Traditional Store Franchise Agreement –Section 13.1), you must pay any contributions that we require to these local or regional cooperatives or that may be otherwise approved by these cooperatives. Your contributions to these local or regional cooperatives, as described below, is calculated by multiplying the percentage outlined in your Franchise Agreement and/or supplemental contribution agreement by the Royalty Sales of your Store (e.g., 8,000 (weekly Royalty Sales) x 2% = \$160).

The advertising contributions you must make to the local or regional cooperatives under the Traditional Store Standard Franchise Agreement (Section 13.2); and the Non-Traditional Store Franchise Agreement (Section 13.2) established for Domino's Pizza Stores are as follows: if 65% or more of the Stores in the cooperative agree or are contractually obligated to contribute a specified percentage of the Royalty Sales, then you must make the same percentage contribution to the cooperative, although we can still require that you contribute no less than 2% of your Royalty Sales to the cooperative. If the Stores have not agreed upon a percentage of Royalty Sales to contribute to the cooperative, you must contribute an amount we specify up to and including 2%

of the Royalty Sales of your Store. The maximum amount we can require that you contribute for advertising fund contributions and local and regional advertising expenditures will be 9% of the weekly Royalty Sales of your Store. Your obligations to contribute to your cooperative under the Franchise Agreement will not affect your obligations to contribute a greater percentage of the Royalty Sales of the Store under any separate agreement or understanding you have with any local or regional advertising or promotional cooperative.

We or our affiliates may hire advertising source(s) to develop, produce and conduct the advertising and promotion programs for the cooperatives with the cooperative advertising budget or contributions you made. (Standard Franchise Agreement – Section 13.2; Non-Traditional Store Franchise Agreement - Section 13.2).

The geographic area for these local and regional advertising cooperatives is defined according to the Nielsen designated marketing areas ("DMA"). The county location of the Store will determine the DMA.

Each cooperative is governed by the Co-op By-laws. A copy of the Co-op By-Laws are given to each new franchisee when they sign their franchise agreement. Before signing the Franchise Agreement, organizational documents may be available to you from the local or regional cooperative. DMAC will be informed of any changes to the Co-op By-laws, and the amended Co-op By-Laws are mailed or made available upon request to all franchisees. We or our affiliates may from time to time, change, dissolve or merge any cooperatives. Members of a Co-op may administer the Co-op or delegate administration to a board of directors.

An independent certified public accountant annually audits the Advertising Fund and cooperatives funds (*i.e.*, one combined audit for all Funds). The results of the combined audit are sent to the DNAF board members and are available to you upon request.

From time to time in the past, we have applied, collected or retained a portion of the contributions or payments made by franchisees under Section 13.2 of the Franchise Agreement for expenditure by the Advertising Fund with the consent of the regional cooperatives ("Roll-Up"). Beginning in May 2009, we began asking all existing and new domestic franchisees to amend Section 13 ("Advertising and Promotion") of their Franchise Agreement (the "2010 Amendment") to authorize us to apply, collect or retain all or part of up to 2% of the Royalty Sales they are required to contribute under Section 13.2 of the Franchise Agreement starting in 2010 for expenditure by the Advertising Fund ("Roll-Up"). Under the 2010 Amendment, which was approved by franchisees, the obligations of franchisees to contribute to the Advertising Fund was reduced to 3½%. The terms of the 2010 Amendment were incorporated into Section 13 of the Franchise Agreement in April 2012. In the fourth quarter of 2012 and the first quarter of 2013, we entered into amendments to the 2010 Amendment and the Franchise Agreements containing the terms of the 2010 Amendment where franchisees agreed to pay 4% of Royalty Sales to the Advertising Fund notwithstanding the existence of a Roll-Up. However, we agreed that, if total cumulative same store sales changes were not positive over 2013 and 2014, a franchisee who signed the 2010 Amendment or the Franchise Agreement incorporating the terms of the 2010 Amendment could ask for a vote of franchisees who signed the 2010 Amendment and Franchise Agreement containing the terms of the 2010 Amendment to reinstate the reduced contribution to

the Advertising Fund as set forth in their 2010 Amendment and Franchise Agreement. The procedures for calling for a vote and for reinstatement of the reduced rate are the same as the procedures set forth below for suspension of a Roll-Up. Franchisees who sign Franchise Agreements in 2013 and thereafter are obligated under the terms of the Franchise Agreement to pay 4% of Royalty Sales to the Advertising Fund notwithstanding a vote of the franchisees who signed the 2010 Amendment or have the terms of the Amendment in Section 13 of their Franchise Agreement. All contributions made by the franchisee that are included in the Roll-Up will be construed as if such allocated funds were paid to the cooperative or for local advertising purposes for purposes of determining the amount of the franchisee's contribution or payments due under Section 13.2.

If we commence a Roll-Up, we may continue the Roll-Up for a period of up to 5 years. Thereafter, we can continue the Roll-Up for additional periods of up to 5 years each unless the consecutive domestic same store sales percentage change reported by Domino's Pizza, Inc. measured from the Roll-Up commencement date until the last day of the fourth year of any such 5 year Roll-Up period is less than .1%. If the same store sales change is less than .1%, we can, nevertheless, continue a Roll-Up for additional periods of up to 5 years unless (a) during the 1st quarter of the 5th year of any such Roll-Up period, a vote is requested in writing by any franchisee in good standing (including, but not limited to, any franchisee not then in default) and who is operating under the Amendment or a Franchise Agreement containing the Roll-Up provision, and (b) 65% of Domino's Pizza stores in good standing and operating under the Amendment or a Franchise Agreement containing the Roll-Up provision vote to suspend such Roll-Up (a "Suspension Vote"). If there is a Suspension Vote, then such Roll-Up will be suspended (the "Suspension") at the conclusion of the 5th year of such Roll-Up. Such Suspension will remain in effect until 65% of Domino's Pizza Stores in good standing and operating under the Amendment or a Franchise Agreement containing the Roll-Up provision vote to reinstate our ability to commence a Roll-Up (the "Reinstatement Vote") after which our ability to effectuate a Roll-Up will be as described above until such time that it is suspended under the procedures described above. For purposes of the Suspension Vote and the Reinstatement Vote, all Domino's Pizza Stores in good standing and operating under the Amendment or a Franchise Agreement containing the Roll-Up provision at the time of such vote and all corporate or affiliate owned Domino's Pizza Stores are entitled to vote on the basis of one vote per Store. We commenced a Roll-Up on January 4, 2010, which is currently in effect.

Computer Systems

All Stores located in the United States are required to install and use the current version of Domino's PULSE. "Current version of Domino's PULSE" means the then current version of software as designated by DPL, or the immediately preceding version of Software.

Domino's PULSE includes the following functions:

- Pizza order and tracking
- Pizza/driver/order tracking
- Employee time clock and labor scheduling
- Cash control and audit capability

- Automated key indicator reporting with ability to transmit keys and other data to DPF
- Cost management and reporting
- Customer database
- Password security and control
- Automated commissary ordering
- Caller ID integration
- Capability to interface with a payroll company or a commercial accounting package
- Capable of polling and reporting in a multi-store environment

You must acquire the Domino's PULSE hardware from a vendor approved by us. The Domino's PULSE hardware includes a Domino's PULSE Server, 3 order taking devices, 1 driver dispatch device, 1 make line device, internet device such as a modem, 1 uninterruptible power supply network hub, router and 3 printer devices. The computer hardware is not proprietary to us or our affiliates. At the present time you must purchase the hardware for Domino's PULSE from Getronics. Service for problems with the Domino's PULSE hardware under warranty can be obtained from Getronics. Service for problems not covered by warranty can be obtained through Getronics or an approved third party service provider.

The current cost estimate per store for the hardware and software required, including payments due DPD, is \$15,000 to \$25,000 (other installation and service fees may apply). The current estimated cost per store for required maintenance and support contracts, third party software license fees, and upgrades or updates should not exceed \$7,000.00 annually. This estimated cost covers the annual enhancement fee, system support services, third party license fees and software upgrades and maintenance, including help desk and support.

DPD is the only approved source for the Domino's PULSE software and you must acquire a license from DPD to use that software (Exhibit J). In connection with the Domino's PULSE License Agreement you will also be required to sign a Participation Agreement with Microsoft (Attachment C to Exhibit J) which is a sublicense of certain Microsoft software that is part of Domino's PULSE.

As noted in Item 8, you have an obligation to make additions, substitutions, replacements and modifications to the Brand Technology. You will not, however, be required to make aggregate expenditures for any additions, substitutions, replacements or modifications to the Brand Technology in excess of one and one half percent (1 ½ %) of the Royalty Sales of the Store from the date of its opening to the date we require you to make any additions, substitutions, replacements or modifications to the Brand Technology, not to exceed the ten (10) year period prior to the date we require you to make any additions, substitutions, replacements or modifications to the Brand Technology or, except in connection with a renewal of the franchise to make any additions, substitutions, replacements or modifications to the Brand Technology during the last twelve (12) months of the initial term of the franchise. This limitation shall not apply to our right to require that you acquire and install the Domino's PULSE store computer system or other components of the Brand Technology upon execution of the franchise agreement nor shall the provisions of any prior franchise agreement governing the operation of the Store restrict our right to require that you

acquire and install the Domino's PULSE store computer system or other components of the Brand Technology under the terms of the franchise agreement.

We and our affiliates will have independent access to the computer data and equipment containing the information, records and reports required by the Franchise Agreement. There are no contractual limitations on our right to access this information. (Franchise Agreement – Sections 9, 14).

As noted in Items 6, 7, and 8, we may develop or contract with third parties to develop Additional Order Systems. These may become mandatory at any time during the term of this Agreement and may require you to spend money to add or replace equipment, wiring, hardware and software; to pay licensing fees, support and maintenance fees, fees paid to third parties; to incur other costs, and to sign agreements with third parties. You currently must participate in an Additional Order System provided by a designated third-party vendor. To the extent these products and services are owned by us or provided to you by us, we may charge up front and/or ongoing fees that may be included as part of the Technology Transaction Fee. However, to the extent all the direct and indirect costs to develop, test and implement an Additional Order System are paid from other sources, then such up-front and ongoing fees charged by us would be intended only to cover our ongoing expenses, including direct costs and reasonable allocations. Regardless of the sources of funds to develop any Additional Order System we shall be the sole owner of all direct and related rights and assets, including software and hardware, intellectual property and all data generated by the Additional Order Systems, but excluding hardware or equipment you purchase directly for the purpose of gaining access to the Additional Order System. You must also comply with all standards, operations and procedures related to e-mail capabilities of the Store and other electronic communication methods (including high-speed broadband connectivity, high-speed broadband monitoring, and methods and means of encryption and access to our network resources) and devices to facilitate communication with us or our offices, including the exchange of information between the Store and us.

We have developed a Global Positioning System technology platform, including a Driver App, that enables the location-tracking of deliveries electronically. Pursuant to the Global Positioning System Technology Platform Agreement attached as Exhibit R ("Global Positioning System Technology Platform Agreement") and operating standards, stores must have the approved Domino's Global Positioning System ("GPS") and Digital Shoulder Surfing ("DSS") technology platforms operational and active during store hours and must use the tracking functionality of the Driver App with a minimum percentage of the store's delivery orders each period as set forth in the current operating standards.

Site Selection

You have the primary responsibility for locating a site. We will approve the location before issuing the franchise agreement for the Store.

We may make a store siting model available to franchisees to use in considering where to locate a Domino's Pizza store. This is a model for site location which has been developed in conjunction with a third party vendor. The model is only a business tool based in part on statistics.

Under the Development Agreement, our approval of a location and the delivery of a Franchise Agreement is conditioned upon our determination that: (i) you have the financial capacity and skills necessary to develop and operate the Store; (ii) the proposed site is within the development area and is suitable based upon our criteria; and (iii) you and your owners comply with the Development Agreement and all Franchise Agreements signed under the Development Agreement and have furnished all information that we requested.

We estimate that there will be an interval of 1 to 6 months between submitting an application and the opening of the Store, but this interval will depend on the location and condition of the site. You must open the Store for business within 6 months after signing the Franchise Agreement unless we agree otherwise.

Training

Prior to applying for and obtaining our approval for the rights to franchise and operate a Domino's Pizza store, you, as the Controlling Person, must complete all training required to operate the Store. The type and duration of the training will depend on whether you have at least twelve (12) consecutive months of current management or supervisory experience within the Domino's Pizza system. All training programs will be held online or at times and places we designate. Generally, our trainers have a minimum of two years of operations experience and are required to be certified General Managers. Brian Trier, Vice President of Global Operations Innovation and Support, oversees training and has been employed by us since July 2004 in the following capacities: International Business Consultant, International Managing Director, and Vice President – Americas Region. Prior to working for the company, Mr. Trier spent twelve years working for a Domino's franchisee in Canada. We may charge a reasonable training fee of up to \$1,250 for these training programs. You must complete all training to our satisfaction. You must pay for travel, living expenses and any other costs incurred during the training.

Once you have completed at least twelve (12) consecutive months of recent successful management or supervisory experience within the Domino's Pizza system, you will be required to complete the franchise pre-qualification process. If qualified, you will be required to complete all of the required tracks of the Franchise Management School ("FMS") to obtain Qualified Franchisee Candidate status. A complete list of these training programs and the dates and times they are offered is provided by Domino's. The materials for these required training programs generally consist of workbooks, manuals, online courses and facilitator-led PowerPoint presentations.

We also may require that you or your owners complete supplemental or additional training programs which we periodically may offer. You must pay for the reasonable costs of these programs, not to exceed \$500 per class, and for the travel and living expenses and any other costs incurred during these programs. You must complete this supplemental or additional training within 1 year of the time in which it is originally offered to you by us.

We will make available the following programs which you will need to successfully complete to qualify to become a franchisee:

Item 11 TABLE

TRAINING PROGRAM

(1) Subject	(2) Hours of Online/Classroom Training	(3) Hours of On-the-Job Training*	(4) Location
Franchise Management School (FMS) - Admissions	Approximately 45-75 hours	Approximately 1-5	In candidate's market
Franchise Management School (FMS) – Undergrad Class	Approximately 8 hours per day for 3 days	0	Ann Arbor, Michigan or online at our sole discretion
Franchise Management School (FMS) – Pre-Grad School	Approximately 45-75 hours	0	In candidate's market
Franchise Management School (FMS) – Grad School	Approximately 8 hours per day for 2 days	0	Ann Arbor, Michigan or online at our sole discretion

* *Estimated hours of on-the-job training is based on the Team Member dividing his/her time between training and working.*

Currently, we grant single store franchises only to applicants who have recently been a successful manager or supervisor of a Store for at least 12 months. The applicant also must have completed certain classes we require as set forth in the chart above. You must complete all training programs and classes to our satisfaction. Some training may be provided by the store manager or franchisee for whom you worked prior to the time you applied for a franchise. We may from time to time accelerate or modify the basic eligibility and training requirements at our discretion based on your operational experience and business acumen. We require that the Controlling Person own 51% or more of the Store. There are also minimum net worth and liquidity requirements depending on the number of Stores to be developed or purchased. The Controlling Person of a Domino's Pizza franchise may not have financial or operational involvement in another business outside of their Domino's Pizza business, without our prior written approval which may be withheld in our sole judgment. There are additional factors that will be considered while reviewing a franchise application.

Franchisees are responsible for training all of their managers and team members.

Once all of the required training has been completed to our satisfaction, the franchise candidate will have 1 year to acquire a franchise otherwise they could be required to attend some or all of the programs as deemed necessary by us, at our sole discretion.

Item 12: Territory

Development Agreement

We have a program for the development of Domino's Pizza Stores in markets in which we have determined, based on studies, to be appropriate for the development of additional Domino's Pizza Stores. We may sign the Development Agreement with franchisees who are given the opportunity to further develop these markets.

You will not receive an exclusive territory under the Development Agreement. You may face competition from other franchisees, from outlets that we own or from other channels of distribution or competitive brands we control. You will receive a development area in which to develop the Stores. Neither we nor our affiliates will operate or grant a franchise for a Store other than to you within this development area during the term of the Development Agreement (unless earlier terminated). The development area, which is outlined on a map, and a corresponding written description is attached to the Development Agreement when it is signed. Enclosed malls, institutions (such as hospitals), airports, parks (including theme parks), sports arenas, convention centers and other facilities or venues where events are scheduled are excluded from the area granted. You will have the first option to service such facility if you meet the legal and/or venue requirements, subject to our approval. The number of Stores you must open each year under the Development Agreement will be inserted when the Development Agreement is signed and will be based, in part, upon the market potential of the development area but must be for a minimum of 1 Store. Each Store location must be approved by us.

We may terminate the Development Agreement, including your territorial rights, upon notice to you if (a) you do not meet the Development Requirements described in Section 4 of the Development Agreement; (b) you or your owners do not comply with any other provision of the Development Agreement; (c) any Domino's Pizza Development Agreement or Franchise Agreement with any entity that you or your Controlling Person directly or indirectly, owns in whole or in part, is terminated by us in accordance with its terms; (d) you and your owners fail to maintain the financial capacity and necessary skills and experience to meet the Development Requirements and timely develop and operate the Stores required to be opened and operated under this Agreement based upon criteria established by us from time to time; or (e) the Controlling Person of the Developer under the Development Agreement is not at any time the Controlling Person of all approved entities operating Stores in the Development Area.

The termination of your Development Agreement will not alter your territorial protection for the Stores you develop as a franchisee. The Development Agreement does not prohibit us or our affiliates from establishing other franchises or company-owned outlets selling similar products or services under a different trade name or trademark within your development area or from distributing products or services offered at Domino's Pizza Stores through other channels of distribution. Only the mutual written agreement of the parties may alter your development area.

Traditional Store Standard Franchise Agreement

You may operate the Store only at a location approved by us. You will not receive an exclusive territory under our Traditional Store Franchise Agreement. You may face competition from other franchisees, from outlets that we own, or from other channels of distribution or competitive brands that we control. You will be assigned an area of primary responsibility. The boundaries of the area of primary responsibility will be inserted in the Standard Franchise Agreement when it is signed. The area of primary responsibility will generally be a 1 mile radius around the Store, a 1 mile radius from a street intersection or a written description equivalent to a 1 mile radius, except that in densely populated areas, it generally will be a ½ mile radius. During the term of the Standard Franchise Agreement, neither we nor our affiliates will operate or grant a franchise for a Store whose area of primary responsibility overlaps your area of primary responsibility.

When the Standard Franchise Agreement is signed, we will define the parameters of the delivery and service area in accordance with our policy. You may periodically be assigned boundaries in which the Domino's Pizza Traditional Store may not offer delivery service. We have the right, in our sole discretion, to adjust the size of your delivery and service area to account for changes in market conditions, population changes or other considerations. During approved hours of operation, you must offer delivery to customers within your delivery and service area according to the rules we periodically establish. You are not required to offer delivery in areas which might present a danger to you or any of your employees. However, you will remain solely responsible for investigating and reviewing periodically, but not less than annually, any decisions by you to limit your delivery area for safety reasons, subject to the procedures and standards we may prescribe from time to time, and for obtaining and maintaining information that supports your decisions to limit delivery service. You understand and agree that you may not change the boundaries of your delivery and service area without our prior written consent. When making deliveries, you and your employees must comply with all laws, regulations and rules of the road and due care and caution.

Enclosed malls, institutions (such as hospitals), airports, parks (including theme parks), sports arenas, convention centers and other facilities or venues where events are scheduled are excluded from your area of primary responsibility and your delivery and service area, unless otherwise specified by us in writing. You will have the first option to service such facility if you meet the legal and/or venue requirements, subject to our approval.

In the event the Store is destroyed or rendered unusable, we may grant permission for the Store to be repaired, restored or reconstructed at the existing location. Any repair, restoration, reconstruction or relocation will be at your sole expense. The Store, whether we grant permission for you to repair, restore, reconstruct or relocate, must be open and operating no later than 6 months after its closure. In addition, within 10 days of vacating the Store premises, you must make such reasonable modifications to the exterior and interior of the Store (including signage, menu boards, job aids, product photos and the like) as we require to fully eliminate its identification and appearance as a Domino's Pizza Store.

We may require that you relocate the Store upon renewal of the Franchise.

The Standard Franchise Agreement does not prohibit us or our affiliates from establishing other franchises or company-owned outlets selling similar products or services under a different trade name or trademark within your area of primary responsibility or from distributing products or services offered at Domino's Pizza Traditional Stores through other channels of distribution.

Continuation of your area of primary responsibility does not depend on your achieving a certain sales volume or market penetration. Provided you are in compliance with the terms of the Standard Franchise Agreement, only the mutual written agreement of the parties may alter your area of primary responsibility.

Non-Traditional Store Franchise Agreement

You may operate the Store only at a location approved by us. You will not receive an exclusive territory under our Non-Traditional Store Franchise Agreement. You may face competition from other franchisees, from outlets that we own, or from other channels of distribution or competitive brands that we control. If you are opening a Domino's Pizza Non-Traditional Store, your area of primary responsibility will be the premises of the store.

In the event the Store is destroyed or rendered unusable, we may grant permission for the Store to be repaired, restored or reconstructed at the existing location. Any repair, restoration, reconstruction or relocation will be at your sole expense. The Store, whether we grant permission for you to repair, restore, reconstruct or relocate, must be open and operating no later than 6 months after its closure. In addition, within 10 days of vacating the Store premises, you must make such reasonable modifications to the exterior and interior of the Store (including signage, menu boards, job aids, product photos and the like) as we require to fully eliminate its identification and appearance as a Domino's Pizza Store.

We may require that you relocate the Store upon renewal of the Franchise.

The Non-Traditional Store Franchise Agreement does not prohibit us or our affiliates from establishing other franchises or company-owned outlets selling similar products or services under a different trade name or trademark within the area of primary responsibility, if any, or from distributing products or services offered at Domino's Pizza Stores through other channels of distribution.

Continuation of the area of primary responsibility, if any, does not depend on your achieving a certain sales volume or market penetration. Provided you are in compliance with the terms of the Non-Traditional Store Franchise Agreement, only the mutual written agreement of the parties may alter the area of primary responsibility.

Item 13: Trademarks

Under the Development Agreement you do not receive any rights to use the Marks. You receive these rights under the Franchise Agreement and License Agreement.

The primary trademarks and service marks are the "Domino's & Design", "Domino's Pizza", "Domino Design Symbol", "Combination Domino Design" and "Domino's Pizza Logo" and names and associated designs (the "Marks"). Under the Franchise Agreements, and License Agreement, we grant you the non-exclusive right to use the Marks to operate the Store. The Marks are owned by DP IP Holder, a wholly owned subsidiary of DPPI. We are authorized to use and sublicense the use of these Marks under a license agreement with DP IP Holder. (described below). DP IP Holder has registration and ownership of these marks on the Principal Register of the United States Patent and Trademark Office ("USPTO") as follows: "Domino's Pizza", Registration Numbers 1,166,751; 1,519,402; and 1,249,196, Registration Dates (August 25, 1981); (January 3, 1989); and (August 23, 1983); "Domino Design Symbol", Registration Numbers 1,529,014; 1,192,280; and 1,296,677, Registration Dates (March 7, 1989); (March 16, 1982); and (September 18, 1984); and "Domino's Game Piece Logo", Registration Number 4,389,262 (August 20, 2013); "Domino's Game Piece Logo", Registration Number 4,354,128 (June 18, 2013); and "Domino's", Registration Number 2,736,837 (July 15, 2003), "Domino's and Design", Registration Number 4,692,802 (February 24, 2015), "Domino's & Design", Registration Number 4,692,804 (February 24, 2015). These are the primary trademarks and service marks but other related trademarks and service marks which have been registered are described in the Operating Manuals. All required affidavits and renewal applications have been filed.

Your right to use the Marks is non-exclusive, and we and our affiliates have the right, among others: (a) to use the Marks to sell products and services; (b) to grant others licenses for the Marks; (c) to develop and establish other systems using the same or similar Marks, or any other proprietary marks, and to grant licenses or franchises in those systems without providing any rights to you; and (d) to regulate the use of the Marks in any form of electronic media including web sites or web pages or as a domain name or electronic media identifier.

Your usage of the Marks and any goodwill you establish is to our and our affiliates exclusive benefit and you retain no right in the Marks when the Franchise Agreement terminates or expires. You must follow our rules when you use the Marks. You may not use the Marks as a part of any corporate or trade name or with any name or symbol you use to operate your Store, nor may you use any trade name, trademark, service mark, emblem or logo other than the Marks we periodically designate.

There are no currently effective material determinations of the USPTO, the Trademark Trial and Appeal Board, the trademark administrator of any state or any court, nor are there any pending infringement, opposition or cancellation proceedings or material litigation, involving the Marks. There are no other agreements currently in effect which significantly limit our right to use or license the use of the Marks that are material to the franchise. We do not actually know of either superior prior rights or infringing uses that could materially affect a franchisee's use of the principal marks in any state.

As part of the Securitization Transaction, the Marks were assigned to DP IP Holder. On the same date, a license agreement between DP IP Holder and DPF was entered into giving DPF the right and license to use and sublicense the use of the Marks. The term of the license agreement is 99 years. DP IP Holder has certain enforcement rights in the event we default under the license agreement, including the right to terminate the license agreement if we fail to cure a default within the time period specified in the license agreement. However, these enforcement rights will not affect your right to operate your Domino's Pizza Store under the Marks or use the Marks under the terms of the Franchise Agreement.

You must immediately notify us of any use by others of names or marks which are the same or confusingly similar to any Marks. We will indemnify you against and reimburse you for all damages you are held liable for in any proceeding from your authorized use of any Mark and for all costs reasonably incurred defending any claim against you or in any proceeding you are named as a party, if you have timely notified us, you have given us sole control of the defense and settlement of any claim, and you have otherwise complied with the Franchise Agreement.

We may require you to modify or discontinue use of any Mark or use one or more additional or substitute Marks in the event a dispute arises over our right to the use of any Mark. If we do, our sole obligation will be to reimburse you for your tangible costs of complying with these requirements.

Item 14: Patents, Copyrights and Proprietary Information

Under the Development Agreement, you do not have the right to use any patents or copyrights. Under the Franchise Agreement and License Agreement, you will have the right to use certain equipment and processes which are described below.

DPI IP Holder has obtained registration of the following patents: Vehicle, PN D743,302, Registered: November 17, 2015; Vehicle Door, PN D743,311, Registered: November 17, 2015; Vehicle Advertising Sign, PN D754,250, Registered: April 19, 2016; Storage Module, PN 9,387,786, Registered: July 12, 2016; Vehicle with Upwardly Mobile Door, PN 9,452,703, Registered: September 27, 2016; Pizza Order Display Panel with a Transitional Graphical User Interface, PN D907,657, Registered: January 12, 2021; Pizza Order Display Panel with a Transitional Graphical User Interface, PN D932,509, Registered October 05, 2021; Pizza Order Display Panel with a Transitional Graphical User Interface, PN D1,012,118, Registered January 23, 2024; Pizza Order Display Panel with a Transitional Graphical User Interface, SN 29/916,806, filed November 15, 2023; Method and System for Centralized Order Status Tracking in a Decentralized Ordering System (Pizza Tracker), PN 10,262,281, Registered: April 16, 2019; Food Assembly Line, PN 10,136,742, Registered: November 27, 2018.

In addition, we and/or our affiliates claim copyright protection in the Operating Manuals, Training Manuals, videotapes and related materials, certain proprietary software, middleware and advertising and promotional materials although these items may or may not be registered with the United States Registrar of Copyrights. The materials are considered proprietary and confidential.

You may only use these materials according to our rules, regulations and guidelines. We have obtained a license to use the patent and various materials under the license agreement described above.

There currently are no effective determinations of the United States Patent and Trademark Office, the United States Copyright Office or any court regarding any of the patented or copyrighted materials. There are no agreements in effect which significantly limit our right to use or license the patented or copyrighted materials. There are no infringing uses actually known to us which could materially affect your use of the patented or copyrighted materials in any state. We are not required by any agreement to protect or defend patents or copyrights.

The dough, sauce and cheese used in Domino's Pizza Stores are proprietary and we may restrict the sources of supply of these products. Information, knowledge, or know-how, including drawings, materials, equipment, marketing, recipes, and other data, that we designate as confidential will be deemed confidential for purposes of the Franchise Agreement. We will disclose to you certain confidential or proprietary information and trade secrets. You must not make an unauthorized use of our confidential or proprietary information or trade secrets and must take steps to prevent its disclosure to others.

Item 15: Obligation to Participate in the Actual Operation of the Franchise Business

If you are a franchisee developing stores under a Development Agreement, you must devote your full time (excepting reasonable vacation periods) to the management and/or supervision of Stores in your development area and make a total commitment to the Domino's Pizza system. If you are an approved entity, the Controlling Person must devote his/her full time (excepting reasonable vacation periods) to the management and/or supervision of Stores within the development area. During the term of the Development Agreement, the Controlling Person may not have financial or operational involvement in another business outside of the Domino's Pizza System, without our written approval which may be withheld in our sole judgment.

The Store must always be under the on-premises supervision of you or the Controlling Person. You or the Controlling Person must devote his/her full time as manager of the Store or to the management of other Stores (or other related activities we approved). You must commit yourself fully to the Store(s) and no other businesses. During the term of the Franchise Agreement, the Controlling Person may not have financial or operational involvement in another business outside of the Domino's Pizza System, without our written approval which may be withheld in our sole judgment. If you own more than one Store, each Store must also be under the on-premises supervision of a properly trained manager whose identity has been disclosed to us, and who has signed an agreement not to divulge any trade secret or confidential or proprietary information, or to engage in or have any interest in any other carry-out or delivery pizza store business.

If you are a corporation, partnership or limited liability company, the Controlling Person must personally guarantee the obligations under the Franchise Agreement or Development Agreement, agree to be personally bound by, and personally liable for every breach of, the

Franchise Agreement or Development Agreement, agree to be bound by the confidentiality, non-disclosure and non-competition provisions of the Franchise Agreement and agree to certain restrictions on his/her ownership interests. Every other shareholder, member or partner must personally guarantee the obligations under the Franchise Agreement or Development Agreement based upon his/her ownership interest in the franchise and must agree to be bound by each provision of the Franchise Agreement or Development Agreement including the confidentiality, non-disclosure and non-competition provisions.

Item 16: Restrictions on What the Franchisee May Sell

You must offer for sale all products we require and make all menu items available for carry-out and delivery from the Store. You may not offer for sale any products that we have not approved (See Items 8 and 9). We can periodically change the types of authorized products and services and there is no limit on our right to make these changes.

We may periodically adjust the boundaries in which your Store offers delivery service to reflect changing market conditions, population changes and other relevant considerations. If we revise these boundaries, you must adjust the size of your delivery service area. During the approved hours of operation, you must offer delivery from your Store to customers within your delivery service area, following the rules we periodically establish. We may permit you to offer delivery services from your Non-Traditional Store. You may serve any customer provided you do so from the Store under our standards. (See Item 12)

Item 17: Renewal, Termination, Transfer and Dispute Resolution

ITEM 17 TABLE:

THE FRANCHISE RELATIONSHIP

This table lists certain important provisions of the franchise and related agreements. You should read these provisions in the agreements attached to this disclosure document.

Provision	Section in Standard Franchise or Non-Traditional Store Franchise Agreement	Summary
a. Term of the franchise	Section 2.2	10 years for the Standard Franchise Agreement and the Non-Traditional Store Franchise Agreement

Provision	Section in Standard Franchise or Non-Traditional Store Franchise Agreement	Summary
b. Renewal or extension of the term	Section 3.1	10 year renewal if you meet certain requirements for the Standard Franchise Agreement and the Non-Traditional Store Franchise Agreement. You are required to sign our then current form of franchise agreement which may contain other terms materially different from the terms of your original franchise agreement.
c. Requirements for you to renew	Sections 3.1 and 3.2	Written notice, not in material default, substantial compliance as defined in the Franchise Agreement; sign then-current form of Franchise Agreement, execute then-current form of general release (see Exhibit K for our current form of release); maintain possession of Store or secure approved substitute premises; complete refurbishing or, if we determine, relocate premises and develop the new premises in accordance with then-current standards for the Standard Franchise Agreement and the Non-Traditional Store Franchise Agreement. You may also be asked to submit an Application for Franchise (Renewal) upon renewal of your franchise (See Exhibit O for our current form).
d. Termination by you	Section 18.1	If DPF has breached Franchise Agreement and does not cure after 30 day written notice.
e. Termination by us without cause	None	
f. Termination by us with cause	Section 18.2	We can terminate only if you commit and fail to cure one of several violations.

Provision	Section in Standard Franchise or Non-Traditional Store Franchise Agreement	Summary
g. "Cause" defined-defaults which cannot be cured	Section 18.2 .1	Material misrepresentation or omission in application; do not open Store within 6 months; bankruptcy; assignment for benefit of creditors; abandonment; violation of child labor laws; loss of possession of Store; felony conviction/ conduct which in our sole judgment involves dishonesty, fraud, deceit, illegal conduct, misrepresentation or moral turpitude; intentional or negligent under-reporting; intentional unauthorized assignment; violation of restrictive covenants; improper disposal of interest of deceased or permanently disabled person; repeated violations; failure to pay overdue amounts within 10 days if audit reveals understatement of royalties or advertising contributions, asset seizure, public health or safety threat, failing to re-open or relocate store within six (6) months after its closure, violations of anti-terrorism provisions for the Standard Franchise Agreement and the Non-Traditional Store Franchise Agreement.
h. "Cause" defined-defaults which can be cured	Sections 18.2.2 and 18.2.3	48-hours for failure to obtain or maintain required insurance; 7 days for failure to comply with our rules for any Mark, safety and security, quality of pizza or other authorized food products; 10 days for failure to pay amounts owed; 30 days for all other defaults. We can also require you to cease operations for health and sanitation reasons; you will have 7 days to cure these deficiencies for the Standard Franchise Agreement and the Non-Traditional Store Franchise Agreement.
i. Your obligations on termination/ non-renewal	Section 18.3	Return Operating Manual; stop using and deliver to us Customer Lists; stop using confidential information and Marks; assign phone numbers; pay outstanding amounts; de-identify; make Store accessible for our operation.
j. Assignment of contract by us	Section 21.1	No restriction on our right to assign.

Provision	Section in Standard Franchise or Non-Traditional Store Franchise Agreement	Summary
k. "Transfer" by you – definition	Section 21.2	Transfer of interest in the Franchise Agreement, Store, assets or you.
l. Our approval of transfer by you	Sections 21.2 and 21.4	We must approve and transferee must satisfy our standards for new franchisees.
m. Conditions for our approval of transfer	Sections 15.9, 21.2 and 21.4	Full compliance, transferee qualifies, transferee is not operating any other pizza store business except other Stores, transferee signs current form of Franchise Agreement, refurbishes Store at our request, completes training and pays transfer fee. We also require a Rider to Purchase Agreement be signed at the time a Purchase Agreement for the Store or Stores is signed (see Exhibit M attached). At the time of the transfer, by mutual agreement of the parties, we will enter into a mutual termination agreement and customary form of release. Any release will be subject to any prohibitions or limitations imposed by applicable state law.
n. Our right of first refusal to acquire your business	Section 21.8	We can match offer.
o. Our option to purchase your business upon termination or non-renewal	Section 19	Purchase for an amount based on percentage of Royalty Sales during 12 months before termination or expiration less certain deductions. If Store open less than 12 months, the amount will be the documented cost of Store. We may also purchase real property at appraised value and if applicable, any commissary at net book value.
p. Your death or disability	Section 21.5	Your personal representative must submit to us a proposal meeting the requirements of transfer within 120 days of your death or permanent disability. Must be transferred to a party approved by us.
q. Non-competition covenants during the term of the franchise	Section 20.1	No involvement in any business similar to that conducted under the Franchise Agreement anywhere.

Provision	Section in Standard Franchise or Non-Traditional Store Franchise Agreement	Summary
r. Non-competition covenants after the franchise is terminated or has expired	Section 20.2	No interest in a competing business for 1 year at the premises of the Store or within 10 miles of the Store.
s. Modification of the agreement	Section 22.5	No modifications but Operating Manual subject to change.
t. Integration/merger clause	Section 22.4 and 22.5	Only Franchise Agreement is binding provided, nothing in our Franchise Agreement or any other agreement is intended to disclaim representations made to you in our franchise disclosure document. This section is also subject to state law.
u. Dispute resolution by arbitration or mediation	None	
v. Choice of forum	None	
w. Choice of law	Section 22.6	Laws of state where Store is located apply.

Provision	Section in Development Agreement	Summary
a. Term of rights	Section 2	Specified in the Development Agreement.
b. Renewal or extension of the term	None in the Development Agreement	
c. Requirements for you to renew or extend	None in the Development Agreement	
d. Termination by you	None	
e. Termination by us without cause	None	
f. Termination by us with cause	Section 9.2 of the Development Agreement	We can terminate only if you commit one of several violations.

Provision	Section in Development Agreement	Summary
g. "Cause" defined-defaults which cannot be cured	Section 9.2 of the Development Agreement	Failure to meet development requirements; failure to otherwise comply with Development Agreement; any Domino's Pizza Franchise Agreement, Area Agreement, Development Agreement with any entity that you or your Controlling Person directly or indirectly, owns in whole or in part is terminated by us in accordance with its terms; you or your owners fail to maintain the financial capacity and necessary skills and experience to meet the Development Requirements and timely develop and operate the Stores required to be opened and operated under the Development Agreement based upon criteria established by us from time to time; or the Controlling Person of the Developer under the Development Agreement is not the Controlling Person of all franchises operating Stores in the Development Area.
h. "Cause" defined-defaults which can be cured	None	
i. Your obligations on termination/expiration	None	
j. Assignment of contract by us	Section 12 of the Development Agreement	No restriction on our right to assign.
k. "Transfer" by you – definition	None	
l. Our approval of transfer by you	Section 13 of the Development Agreement	You or your owners may not assign.
m. Conditions for our approval of transfer	Section 13 of the Development Agreement	Not applicable.

Provision	Section in Development Agreement	Summary
n. Our right of first refusal to acquire your business	None	
o. Our option to purchase your business	None	
p. Your death or disability	None	
q. Non-competition covenants during the term	Section 11 of the Development Agreement	No other business activity during the term of the Development Agreement without our consent.
r. Non-competition covenants after the franchise is terminated	None	
s. Modification of the agreement	None	
t. Integration/merger clause	Section 14 of the Development Agreement	Development Agreement is binding, provided nothing in the Development Agreement or any other agreement is intended to disclaim representation made to you in our franchise disclosure document. This section is also subject to state law.
u. Dispute resolution by arbitration or mediation	None	
v. Choice of forum	None	
w. Choice of law	Section 16 of the Development Agreement	Laws of state where the Development Area is predominantly located apply.

Item 18: Public Figures

We do not use any public figure to promote our franchise.

Item 19: Financial Performance Representations

The FTC’s Franchise Rule permits a franchisor to provide information about the actual or potential financial performance of its franchised and/or franchisor-owned outlets, if there is a reasonable basis for the information, and if the information is included in the disclosure document. Financial performance information that differs from that included in Item 19 may be given only if: (1) a franchisor provided the actual records of an existing outlet you are considering buying; or (2) a franchisor supplements the information provided in this Item 19, for example, by providing information about performance at a particular location or under particular circumstances.

Set forth below is information concerning the average weekly unit sales (“AWUS”) and other financial data of franchised and company-owned Domino's Pizza Traditional Stores located in the United States (not including Stores located in U.S. territories of Guam, Puerto Rico and U.S. Virgin Islands), for the calendar years 2019 through 2023. AWUS is calculated by dividing the total Royalty Sales reported by all Stores operating during the year by the number of weeks reported. Royalty Sales means the total receipts from all sales by the Stores of all pizza, beverages and other products or services authorized for sale at the Stores or at any approved off-site location but exclusive of sales or equivalent taxes, coupon and similar discounts, and beverage container deposits approved by us.

AWUS

	<u>2019</u>	<u>2020</u>	<u>2021</u>	<u>2022</u>	<u>2023</u>
Franchised	\$22,843	\$25,264	\$26,004	\$25,554	\$25,825
Company-Owned	\$24,112	\$26,579	\$25,399	\$23,663	\$25,509
Combined	\$22,914	\$25,336	\$25,970	\$25,334	\$25,810

MEDIAN WEEKLY UNIT SALES

	<u>2019</u>	<u>2020</u>	<u>2021</u>	<u>2022</u>	<u>2023</u>
Franchised	\$21,448	\$23,845	\$24,739	\$24,322	\$24,594
Company-Owned	\$23,585	\$25,776	\$24,683	\$24,248	\$25,535
Combined	\$21,663	\$24,004	\$24,735	\$24,322	\$24,665

For 2019 there were 5,494 franchised stores and 326 company-owned stores for a total of 5,821 stores. For 2020 there were 5,757 franchised stores and 335 company-owned stores for a total of 6,092 stores. For 2021 there were 5,965 franchised stores and 351 company-owned stores for a total of 6,316 stores. For 2022 there were 6,232 franchised stores and 275 company-owned stores for a total of 6,507 stores. For 2023 there were 6,371 franchised stores and 276 company-owned stores for a total of 6,647 stores. These Store counts include all Stores open at year end that were open and operational for the full twelve-month period of the applicable year. In 2023, the average number of households in the delivery areas of these Domino's Pizza Stores with delivery service areas was 14,175, and the average dollar per household was approximately \$2.85.

The charts below show the number and percentage of Stores in operation during the entire twelve-month period which achieved or exceeded AWUS for the applicable year.

	<u>2019</u>	<u>2020</u>	<u>2021</u>	<u>2022</u>	<u>2023</u>
Franchised	2,354	2,503	2,631	3,036	3,213
Company-Owned	177	179	161	152	137
Combined	2,531	2,682	2,797	3,188	3,355

	<u>2019</u>	<u>2020</u>	<u>2021</u>	<u>2022</u>	<u>2023</u>
Franchised	43%	43%	44%	50%	<u>50%</u>
Company-Owned	54%	53%	46%	52%	<u>50%</u>
Combined	43%	44%	44%	50%	<u>50%</u>

OTHER FINANCIAL DATA

Set forth below are calculations of EBITDA as a percentage of Royalty Sales and other financial indicators based upon AWUS of <\$15,000, \$15,001 - \$20,000, \$20,001 - \$25,000, \$25,001 - \$30,000 and \$30,001+. These pro forma statements have been derived from profit and loss statements submitted by franchised stores in operation as of the end of the fiscal year 2023 that have operated for at least twelve (12) months. At the end of 2023, there were 6,548 franchised stores in operation. These calculations are based on the information received from 6,301 Stores. 70 Stores did not submit or submitted incomplete or improperly prepared profit and loss statements and 177 Stores were not operational for the full year. Accordingly, these 247 Stores were excluded from these calculations.

Average Weekly Unit Sales	<\$15,000	\$15,001-\$20,000	\$20,001-\$25,000	\$25,001-\$30,000	\$30,001+
Total Variable Costs	80.8%	78.2%	76.8%	76.1%	<u>76.0%</u>
Total Cash Fixed Costs	20.7%	16.9%	14.8%	13.2%	<u>11.2%</u>
EBITDA	1.0%	7.3%	10.7%	13.0%	<u>15.1%</u>

560 stores were included in the <\$15,000 range, and 271, or 48.3% of these stores achieved or exceeded the 1.1% EBITDA. 1,169 stores had AWUS in the \$15,001 to \$20,000 range, and 603, or 51.6% of these stores achieved or exceeded the 7.3% EBITDA. 1,510 stores had AWUS in the \$20,001 to \$25,000 range, and 809, or 53.6% of these stores achieved or exceeded the 10.7% EBITDA. 1,303 stores had AWUS in the \$25,001 to \$30,000 range, and 673, or 51.7% of these stores achieved or exceeded the 13.0% EBITDA. 1,759 stores had AWUS in the

\$30,001+ range, and 889, or 50.5% of these stores achieved or exceeded the 15.1% EBITDA.

Explanatory Notes:

Total Variable Costs: Includes operating expenses that tend to vary with a change in sales. These expenses include food costs; variable labor costs (which may vary depending on each store's local labor market and applicable wage and working condition requirements), excluding manager salary; bonus; payroll taxes; worker's compensation insurance; mileage reimbursement and related delivery expenses; advertising expenses; royalty expense; and operating supplies.

Total Cash Fixed Costs: Includes operating expenses that tend to not vary with a change in sales. These expenses include telephone and utilities, rent, repairs and maintenance, professional fees, small equipment and computer expenses, other taxes (real and personal property taxes and business taxes), insurance (excluding worker's compensation), manager salary, and miscellaneous operating expenses.

EBITDA: Earnings before interest, taxes, depreciation and amortization. EBITDA is calculated as follows: Royalty Sales minus Total Variable Costs minus Total Cash Fixed Costs plus Supply Chain Profit Sharing and Volume Discount rebates.

Written substantiation for the financial performance representation will be made available to the prospective franchisee upon reasonable request.

Some Stores have achieved these sales or earned these amounts. Your individual results may differ. There is no assurance that you will achieve these sales or earn as much.

We or our affiliates also may furnish supplemental data concerning specific proposed store locations or Delivery Service Areas ("DSA") that are prepared using a siting model program known as "Domino's Strategic Integrated Mapping and Modeling System". We or our affiliates may also furnish supplemental data concerning specific proposed store locations in connection with the proposal by existing Domino's Pizza franchisees to open an additional store in a DSA in which such franchisee has an existing store (a "Store Split") or to open one or more additional stores in contiguous DSAs in which such franchisee has existing stores and to redraw the boundaries of the DSAs ("Store Realignment"). If data generated by the Siting Model is furnished to you, you will be provided with a Supplemental Financial Performance Representation explaining the Siting Model in greater detail and the way in which the information differs from the information contained in this disclosure concerning average weekly unit sales and other financial data of Domino's Pizza stores.

Other than the preceding financial performance representations and the information set forth above and data to substantiate and support the information set forth above, we do not make any financial performance representations. We also do not authorize our employees or representatives to make any such representations either orally or in writing. If you are

purchasing an existing outlet, however, we may provide you with the actual records of that outlet. If you receive any other financial performance information or projections of your future income, you should report it to the franchisor’s management by contacting Colleen McCormick, Senior Manager - Regulatory Affairs and Contracts, at colleen.mccormick@dominos.com, (734) 930-4331, the Federal Trade Commission, and the appropriate state regulatory agencies.

Item 20: Outlets and Franchisee Information

ITEM 20 TABLE NO. 1
Systemwide Traditional Outlet Summary
For years 2021, 2022, 2023

(1) Outlet Type	(2) Year	(3) Outlets at the Start of the Year	(4) Outlets at the End of the Year	(5) Net Change
Traditional Franchised	2021	6030	6222	+192
	2022	6222	6438	+216
	2023	6438	6600	+162
Traditional Company-Owned	2021	362	375	+13
	2022	375	286	-89
	2023	286	288	+2
Total Outlets	2021	6392	6597	+205
	2022	6597	6724	+127
	2023	6724	6888	+164

ITEM 20 TABLE NO. 1
Systemwide Non-Traditional Outlet Summary
For years 2021, 2022, 2023

(1) Outlet Type	(2) Year	(3) Outlets at the Start of the Year	(4) Outlets at the End of the Year	(5) Net Change
Non-Traditional Franchised	2021	18	21	+3
	2022	21	20	-1
	2023	20	21	+1
Non-Traditional Company-Owned	2021	0	0	0
	2022	0	0	0
	2023	0	0	0
Total Outlets	2021	18	21	+3
	2022	21	20	-1
	2023	20	21	+1

ITEM 20 TABLE NO. 1
Systemwide Development Agreement Summary
For years 2021, 2022, 2023

(1) Outlet Type	(2) Year	(3) Outlets at the Start of the Year	(4) Outlets at the End of the Year	(5) Net Change
Development Agreements	2021	228	191	-37
	2022	191	168	-23
	2023	168	226	+58

ITEM 20 TABLE NO. 2
Transfers of Traditional Outlets from Franchisees to New Owners (other than the
Franchisor)
For years 2021, 2022, 2023

(1) State	(2) Year	(3) Number of Transfers
AK	2021	1
	2022	0
	2023	0
AL	2021	1
	2022	4
	2023	1
AR	2021	8
	2022	7
	2023	0
AZ	2021	26
	2022	1
	2023	3
CA	2021	81
	2022	33
	2023	18
CO	2021	34
	2022	9
	2023	5
CT	2021	1
	2022	2
	2023	1
DC	2021	0
	2022	0
	2023	9

(1)	(2)	(3)
State	Year	Number of Transfers
DE	2021	0
	2022	0
	2023	0
FL	2021	58
	2022	64
	2023	39
GA	2021	6
	2022	12
	2023	43
HI	2021	0
	2022	0
	2023	0
IA	2021	2
	2022	2
	2023	0
ID	2021	6
	2022	1
	2023	0
IL	2021	13
	2022	21
	2023	17
IN	2021	28
	2022	7
	2023	12
KS	2021	2
	2022	6
	2023	22
KY	2021	21
	2022	12
	2023	0
LA	2021	5
	2022	2
	2023	7
MA	2021	15
	2022	16
	2023	29
MD	2021	3
	2022	9
	2023	23
ME	2021	0
	2022	0
	2023	0

(1)	(2)	(3)
State	Year	Number of Transfers
MI	2021	11
	2022	15
	2023	13
MN	2021	9
	2022	1
	2023	1
MO	2021	23
	2022	2
	2023	25
MS	2021	3
	2022	21
	2023	0
MT	2021	2
	2022	0
	2023	0
NC	2021	28
	2022	19
	2023	9
ND	2021	0
	2022	0
	2023	4
NE	2021	0
	2022	16
	2023	2
NH	2021	5
	2022	0
	2023	1
NJ	2021	9
	2022	2
	2023	23
NM	2021	0
	2022	0
	2023	0
NV	2021	0
	2022	0
	2023	0
NY	2021	6
	2022	22
	2023	0
OH	2021	36
	2022	65
	2023	18

(1)	(2)	(3)
State	Year	Number of Transfers
OK	2021	4
	2022	5
	2023	2
OR	2021	9
	2022	2
	2023	9
PA	2021	13
	2022	10
	2023	16
RI	2021	4
	2022	2
	2023	5
SC	2021	10
	2022	0
	2023	28
SD	2021	0
	2022	0
	2023	0
TN	2021	38
	2022	12
	2023	14
TX	2021	17
	2022	17
	2023	34
UT	2021	6
	2022	3
	2023	0
VA	2021	1
	2022	12
	2023	52
VT	2021	6
	2022	3
	2023	1
WA	2021	9
	2022	4
	2023	31
WI	2021	3
	2022	2
	2023	3
WV	2021	2
	2022	0
	2023	2

(1)	(2)	(3)
State	Year	Number of Transfers
WY	2021	2
	2022	0
	2023	1
PR	2021	0
	2022	0
	2023	0
U.S.V.I.	2021	0
	2022	0
	2023	0
Totals	2021	567
	2022	443
	2023	523

ITEM 20 TABLE NO. 2
Transfers of Non-Traditional Outlets from Franchisees to New Owners (other than the Franchisor)
For years 2021, 2022, 2023

(1)	(2)	(3)
State	Year	Number of Transfers
AL	2021	0
	2022	0
	2023	0
CA	2021	1
	2022	0
	2023	0
FL	2021	1
	2022	0
	2023	0
IN	2021	1
	2022	0
	2023	0
NC	2021	1
	2022	0
	2023	0
Totals	2021	4
	2022	0
	2023	0

ITEM 20 TABLE NO. 2
Transfers of Development Agreements from Franchisees to New Owners (other than the Franchisor)
For years 2021, 2022, 2023

(1) State	(2) Year	(3) Number of Transfers
Totals	2021	1
	2022	0
	2023	0

ITEM 20 TABLE NO. 3
Status of Traditional Franchised Outlets
For years 2021, 2022, 2023

(1) State	(2) Year	(3) Outlets at Start of Year	(4) Outlets Opened	(5) Terminations (1)	(6) Non-Renewals (2)	(7) Reacquired by Franchisor	(8) Ceased Operations Other Reasons (3)	(9) Outlets at End of the Year
AK	2021	9	1	0	0	0	0	10
	2022	10	1	0	0	0	0	11
	2023	11	1	0	0	0	0	12
AL	2021	122	7	0	0	0	0	129
	2022	129	2	0	0	0	0	131
	2023	131	4	0	0	0	1	134
AR	2021	66	2	0	0	0	0	68
	2022	68	2	0	0	0	0	70
	2023	70	5	0	0	0	0	75
AZ	2021	54	1	0	0	0	0	55
	2022	55	66	0	0	0	0	121
	2023	121	6	0	0	0	0	127
CA	2021	565	19	4	0	0	0	580
	2022	580	6	0	0	0	0	586
	2023	586	9	5	1	0	0	589
CO	2021	132	2	0	0	0	0	134
	2022	134	4	0	0	0	0	138
	2023	138	10	0	0	0	0	148
CT	2021	53	0	0	0	0	1	52
	2022	52	0	0	0	0	0	52
	2023	52	2	0	0	0	0	54
DC	2021	9	0	0	0	0	0	9
	2022	9	0	0	0	0	0	9
	2023	9	0	0	0	0	0	9

(1) State	(2) Year	(3) Outlets at Start of Year	(4) Outlets Opened	(5) Terminations (1)	(6) Non- Renewals (2)	(7) Reacquired by Franchisor	(8) Ceased Operations Other Reasons (3)	(9) Outlets at End of the Year
DE	2021	26	0	0	0	0	0	26
	2022	26	0	0	0	0	0	26
	2023	26	0	0	0	0	0	26
FL	2021	368	14	0	0	0	0	382
	2022	382	16	0	0	0	0	398
	2023	398	11	0	0	0	1	408
GA	2021	219	6	0	0	0	0	225
	2022	225	5	0	0	0	0	230
	2023	230	8	0	0	0	0	238
HI	2021	22	0	0	0	0	0	22
	2022	22	2	0	0	0	0	24
	2023	24	2	0	0	0	0	26
IA	2021	43	4	0	0	0	0	47
	2022	47	2	0	0	0	0	49
	2023	49	5	0	0	0	0	54
ID	2021	44	1	0	0	0	0	45
	2022	45	0	0	0	0	0	45
	2023	45	1	0	0	0	0	46
IL	2021	212	5	0	0	0	0	217
	2022	217	7	0	0	0	0	224
	2023	224	5	0	0	0	1	228
IN	2021	116	10	0	0	0	0	126
	2022	126	6	0	0	0	0	132
	2023	132	4	0	0	0	1	135
KS	2021	44	3	0	0	0	0	47
	2022	47	2	0	0	0	0	49
	2023	49	3	2	0	0	0	50
KY	2021	95	1	0	0	0	0	96
	2022	96	2	0	0	0	0	98
	2023	98	2	0	0	0	0	100
LA	2021	107	1	0	0	0	0	108
	2022	108	2	0	0	0	0	110
	2023	110	0	0	0	0	0	110
MA	2021	132	5	1	0	0	1	135
	2022	135	3	0	0	0	0	138
	2023	138	4	0	0	0	0	142
MD	2021	85	1	0	0	0	0	86
	2022	86	1	0	0	0	1	86
	2023	86	0	0	0	0	0	86

(1) State	(2) Year	(3) Outlets at Start of Year	(4) Outlets Opened	(5) Terminations (1)	(6) Non- Renewals (2)	(7) Reacquired by Franchisor	(8) Ceased Operations Other Reasons (3)	(9) Outlets at End of the Year
ME	2021	26	0	0	0	0	0	26
	2022	26	0	0	0	0	0	26
	2023	26	2	0	0	0	0	28
MI	2021	128	7	0	2	0	1	132
	2022	132	5	0	1	23	0	113
	2023	113	8	0	0	0	0	121
MN	2021	133	4	0	0	0	1	136
	2022	136	3	0	0	0	0	139
	2023	139	1	0	0	0	0	140
MO	2021	146	7	0	0	0	0	153
	2022	153	2	1	0	0	1	153
	2023	153	5	1	0	0	0	157
MS	2021	72	2	0	0	0	0	74
	2022	74	0	0	0	0	0	74
	2023	74	2	0	0	0	0	76
MT	2021	22	2	0	0	0	0	24
	2022	24	1	0	0	0	0	25
	2023	25	1	0	0	0	0	26
NC	2021	289	4	0	0	0	0	293
	2022	293	4	0	0	0	1	296
	2023	296	5	0	0	0	0	301
ND	2021	16	0	0	0	0	0	16
	2022	16	0	0	0	0	0	16
	2023	16	1	0	0	0	0	17
NE	2021	28	3	0	0	0	0	31
	2022	31	2	0	0	0	0	33
	2023	33	0	0	0	0	0	33
NH	2021	29	3	0	0	0	0	32
	2022	32	2	0	0	0	0	34
	2023	34	3	0	0	0	0	37
NJ	2021	165	5	0	0	0	0	170
	2022	170	3	0	0	0	0	173
	2023	173	1	0	0	0	0	174
NM	2021	58	3	0	0	0	0	61
	2022	61	0	0	0	0	0	61
	2023	61	1	0	0	0	0	62
NV	2021	19	1	0	0	0	0	20
	2022	20	0	0	0	0	0	20
	2023	20	0	0	0	0	0	20

(1) State	(2) Year	(3) Outlets at Start of Year	(4) Outlets Opened	(5) Terminations (1)	(6) Non- Renewals (2)	(7) Reacquired by Franchisor	(8) Ceased Operations Other Reasons (3)	(9) Outlets at End of the Year
NY	2021	227	5	0	0	0	0	232
	2022	232	1	0	0	0	0	233
	2023	233	5	0	0	0	1	237
OH	2021	259	9	0	0	0	0	268
	2022	268	4	1	0	0	2	269
	2023	269	7	0	0	0	1	275
OK	2021	78	4	0	0	0	1	81
	2022	81	1	0	0	0	0	82
	2023	82	4	0	0	0	0	86
OR	2021	81	2	0	0	0	0	83
	2022	83	4	0	0	0	0	87
	2023	87	1	0	0	0	0	88
PA	2021	235	8	0	0	0	0	243
	2022	243	11	3	0	0	1	250
	2023	250	10	0	0	0	0	260
RI	2021	26	0	0	0	0	0	26
	2022	26	0	0	0	0	0	26
	2023	26	0	0	0	0	0	26
SC	2021	112	2	0	0	0	0	114
	2022	114	1	0	0	0	0	115
	2023	115	2	0	0	0	0	117
SD	2021	17	0	0	0	0	0	17
	2022	17	0	0	0	0	0	17
	2023	17	2	0	0	0	0	19
TN	2021	162	7	0	0	0	0	169
	2022	169	5	0	0	0	0	174
	2023	174	7	0	0	0	0	181
TX	2021	600	26	0	0	0	0	626
	2022	626	15	0	0	0	0	641
	2023	641	20	0	0	0	0	661
UT	2021	28	1	0	0	0	0	29
	2022	29	51	0	0	0	0	80
	2023	80	1	0	0	0	0	81
VA	2021	169	6	0	0	0	0	175
	2022	175	2	0	0	0	1	176
	2023	176	0	0	0	0	0	176
VT	2021	15	0	0	0	0	0	15
	2022	15	1	0	0	0	0	16
	2023	16	0	0	0	0	0	16

(1) State	(2) Year	(3) Outlets at Start of Year	(4) Outlets Opened	(5) Terminations (1)	(6) Non- Renewals (2)	(7) Reacquired by Franchisor	(8) Ceased Operations Other Reasons (3)	(9) Outlets at End of the Year
WA	2021	150	3	0	0	0	0	153
	2022	153	2	0	0	0	0	155
	2023	155	2	0	0	0	0	157
WI	2021	106	3	0	0	0	0	109
	2022	109	2	0	0	0	0	111
	2023	111	4	0	0	0	0	115
WV	2021	41	0	0	0	0	0	41
	2022	41	0	0	0	0	1	40
	2023	40	0	0	0	0	0	40
WY	2021	22	1	0	0	0	0	23
	2022	23	0	0	0	0	0	23
	2023	23	1	0	0	0	0	24
GUAM	2021	7	0	0	0	0	0	7
	2022	7	0	0	0	0	0	7
	2023	7	0	0	0	0	0	7
PR	2021	39	3	0	0	0	0	42
	2022	42	2	0	0	0	0	44
	2023	44	0	0	0	0	1	43
U.S.V.I.	2021	2	0	0	0	0	0	2
	2022	2	0	0	0	0	0	2
	2023	2	0	0	0	0	0	2
Totals	2021	6030	204	5	2	0	5	6222
	2022	6222	253	5	1	23	8	6438
	2023	6438	178	8	1	0	7	6600

Notes to Table No. 3:

- (1) Terminations include situations where the outlet closed due to the Franchise Agreement being terminated by DPF for cause.
- (2) Non-Renewals include situations where the outlet closed due to the Franchise Agreement expiring and the franchisee not entering into a new Franchise Agreement.
- (3) Ceased Operations include situations where the outlet closed due to the Franchise Agreement being terminated mutually by DPF and the franchisee.

ITEM 20 TABLE NO. 3
Status of Non-Traditional Franchised Outlets
For years 2021, 2022, 2023

(1) State	(2) Year	(3) Outlets at Start of Year	(4) Outlets Opened	(5) Terminations (1)	(6) Non- Renewals (2)	(7) Reacquired by Franchisor	(8) Ceased Operations Other Reasons (3)	(9) Outlets at End of the Year
AK	2021	1	0	0	0	0	0	1
	2022	1	0	0	0	0	1	0
	2023	0	0	0	0	0	0	0
AL	2021	2	0	0	0	0	0	2
	2022	2	0	0	0	0	0	2
	2023	2	0	0	0	0	0	2
CA	2021	1	0	0	0	0	0	1
	2022	1	0	0	0	0	0	1
	2023	1	0	0	0	0	0	1
FL	2021	3	0	0	0	0	0	3
	2022	3	0	0	0	0	0	3
	2023	3	0	0	0	0	0	3
GA	2021	1	0	0	0	0	0	1
	2022	1	0	0	0	0	0	1
	2023	1	0	0	0	0	0	1
IN	2021	0	1	0	0	0	0	1
	2022	1	0	0	0	0	0	1
	2023	1	0	0	0	0	0	1
KS	2021	0	0	0	0	0	0	0
	2022	0	0	0	0	0	0	0
	2023	0	1	0	0	0	0	1
LA	2021	1	0	0	0	0	0	1
	2022	1	0	0	0	0	0	1
	2023	1	0	0	0	0	0	1
MO	2021	1	0	0	0	0	0	1
	2022	1	0	0	0	0	0	1
	2023	1	0	0	0	0	0	1
MS	2021	1	0	0	0	0	0	1
	2022	1	0	0	0	0	0	1
	2023	1	0	0	0	0	0	1
NC	2021	3	1	0	0	0	0	4
	2022	4	0	0	0	0	0	4
	2023	4	0	0	0	0	0	4

(1) State	(2) Year	(3) Outlets at Start of Year	(4) Outlets Opened	(5) Terminations (1)	(6) Non- Renewals (2)	(7) Reacquired by Franchisor	(8) Ceased Operations Other Reasons (3)	(9) Outlets at End of the Year
NM	2021	2	0	0	0	0	0	2
	2022	2	0	0	0	0	0	2
	2023	2	0	0	0	0	0	2
SC	2021	1	0	0	0	0	0	1
	2022	1	0	0	0	0	0	1
	2023	1	0	0	0	0	0	1
TN	2021	0	1	0	0	0	0	1
	2022	1	0	0	0	0	0	1
	2023	1	0	0	0	0	0	1
GUAM	2021	1	0	0	0	0	0	1
	2022	1	0	0	0	0	0	1
	2023	1	0	0	0	0	0	1
Totals	2021	18	3	0	0	0	0	21
	2022	21	0	0	0	0	1	20
	2023	20	1	0	0	0	0	21

Notes to Table No. 3:

- (1) Terminations include situations where the outlet closed due to the Franchise Agreement being terminated by DPF for cause.
- (2) Non-Renewals include situations where the outlet closed due to the Franchise Agreement expiring and the franchisee not entering into a new Franchise Agreement.
- (3) Ceased Operations include situations where the outlet closed due to the Franchise Agreement being terminated mutually by DPF and the franchisee.

ITEM 20 TABLE NO. 3
Status of Development Agreements (“DA”)
For years 2021, 2022, 2023

(1) State	(2) Year	(3) DA at Start of Year	(4) New DA Opened	(5) Terminations (1)	(6) Non-Renewals (2)	(7) Reacquired by Franchisor	(8) Ceased Operations Other Reasons (3)	(9) DA at End of the Year
AK	2021	1	0	0	0	0	0	1
	2022	1	0	0	0	0	0	1
	2023	1	0	0	0	0	0	1
AL	2021	7	1	0	3	0	0	5
	2022	5	0	0	2	0	1	2
	2023	2	4	0	1	0	0	5
AR	2021	6	0	0	3	0	0	3
	2022	3	1	0	1	0	0	3
	2023	3	1	0	0	0	1	3
AZ	2021	4	0	0	0	0	0	4
	2022	4	2	0	0	0	1	5
	2023	5	4	0	1	0	2	6
CA	2021	11	1	1	1	0	0	10
	2022	10	0	0	1	0	0	9
	2023	9	9	0	0	0	5	13
CO	2021	7	0	2	0	0	0	5
	2022	5	1	0	0	0	1	5
	2023	5	7	0	1	0	4	7
CT	2021	2	0	0	1	0	0	1
	2022	1	0	0	0	0	0	1
	2023	1	2	0	0	0	1	2
DE	2021	3	0	0	0	0	0	3
	2022	3	0	0	0	0	1	2
	2023	2	0	0	0	0	2	0
FL	2021	12	5	2	1	0	0	14
	2022	14	3	0	1	0	0	16
	2023	16	14	0	5	0	5	20
GA	2021	5	1	0	1	0	0	5
	2022	5	1	0	2	0	1	3
	2023	3	7	0	0	0	3	7
HI	2021	1	0	0	0	0	0	1
	2022	1	0	0	0	0	0	1
	2023	1	1	0	0	0	1	1

IA	2021	4	0	0	1	0	0	3
	2022	3	2	0	1	0	0	4
	2023	4	3	0	0	0	3	4
ID	2021	4	0	0	2	0	0	2
	2022	2	0	0	2	0	0	0
	2023	0	2	0	0	0	0	2
IL	2021	7	0	1	0	0	0	6
	2022	6	0	0	3	0	0	3
	2023	3	1	0	1	0	1	2
IN	2021	9	1	1	1	0	0	8
	2022	8	0	1	1	0	0	6
	2023	6	4	0	0	0	1	9
KS	2021	5	0	0	1	0	0	4
	2022	4	0	1	0	0	0	3
	2023	3	1	0	0	0	1	3
KY	2021	3	0	0	1	0	0	2
	2022	2	0	1	0	0	0	1
	2023	1	5	0	0	0	1	5
LA	2021	2	0	0	1	0	0	1
	2022	1	0	0	0	0	0	1
	2023	1	1	0	0	0	0	2
MA	2021	1	0	0	0	0	0	1
	2022	1	0	0	0	0	0	1
	2023	1	3	0	0	0	1	3
MD	2021	2	0	0	0	0	0	2
	2022	2	0	0	0	0	0	2
	2023	2	0	0	0	0	2	0
ME	2021	1	0	0	0	0	0	1
	2022	1	0	0	0	0	0	1
	2023	1	0	0	0	0	1	0
MI	2021	7	0	0	0	0	0	7
	2022	7	4	0	1	0	1	9
	2023	9	1	0	3	0	0	7
MN	2021	4	0	0	1	0	0	3
	2022	3	2	0	1	0	0	4
	2023	4	0	0	1	0	1	2
MO	2021	8	0	0	0	0	0	8
	2022	8	0	0	0	0	0	8
	2023	8	4	1	0	0	3	8
MS	2021	2	1	0	1	0	0	2
	2022	2	0	0	1	0	0	1
	2023	1	3	0	1	0	0	3
MT	2021	4	0	0	1	0	0	3
	2022	3	0	0	0	0	0	3
	2023	3	1	0	0	0	1	3

NC	2021	5	0	0	1	0	0	4
	2022	4	0	0	0	0	1	3
	2023	3	7	0	1	0	1	8
ND	2021	2	0	0	1	0	0	1
	2022	1	1	0	0	0	0	2
	2023	2	1	0	0	0	1	2
NE	2021	3	1	0	1	0	0	3
	2022	3	2	0	1	0	2	2
	2023	2	1	0	0	0	2	1
NH	2021	1	0	0	0	0	0	1
	2022	1	0	0	0	0	0	1
	2023	1	3	0	0	0	1	3
NJ	2021	3	0	0	1	0	0	2
	2022	2	0	0	0	0	1	1
	2023	1	4	0	0	0	1	4
NM	2021	1	0	0	0	0	0	1
	2022	1	0	0	0	0	0	1
	2023	1	1	0	0	0	1	1
NV	2021	2	0	0	1	0	0	1
	2022	1	1	0	0	0	0	2
	2023	2	1	0	1	0	1	1
NY	2021	5	0	0	2	0	0	3
	2022	3	0	0	0	0	0	3
	2023	3	2	0	0	0	1	4
OH	2021	8	2	2	4	0	0	4
	2022	4	1	1	0	0	0	4
	2023	4	6	0	0	0	2	8
OK	2021	6	0	1	1	0	0	4
	2022	4	0	0	0	0	0	4
	2023	4	3	0	0	0	3	4
OR	2021	4	0	0	0	0	0	4
	2022	4	0	0	0	0	0	4
	2023	4	5	0	0	0	4	5
PA	2021	8	1	0	4	0	0	5
	2022	5	2	0	1	0	1	5
	2023	5	10	0	1	0	4	10
RI	2021	0	0	0	0	0	0	0
	2022	0	0	0	0	0	0	0
	2023	0	1	0	0	0	0	1
SC	2021	5	1	1	0	0	0	5
	2022	5	1	0	1	0	2	3
	2023	3	5	0	0	0	3	5
SD	2021	1	0	0	0	0	0	1
	2022	1	0	0	0	0	0	1
	2023	1	2	0	0	0	1	2

TN	2021	8	1	1	1	0	0	7
	2022	7	0	0	0	0	1	6
	2023	6	7	0	1	0	4	8
TX	2021	21	1	1	2	0	0	19
	2022	19	0	0	2	0	2	15
	2023	15	19	0	1	0	9	24
UT	2021	2	0	0	0	0	0	2
	2022	2	0	0	0	0	0	2
	2023	2	3	0	1	0	1	3
VA	2021	6	2	0	1	0	0	7
	2022	7	0	0	2	0	1	4
	2023	4	3	0	0	0	3	4
VT	2021	1	0	0	0	0	0	1
	2022	1	0	0	1	0	0	0
	2023	0	2	0	0	0	0	2
WA	2021	6	0	0	1	0	0	5
	2022	5	0	0	2	0	0	3
	2023	3	2	0	0	0	3	2
WI	2021	5	1	0	2	0	0	4
	2022	4	1	0	1	0	0	4
	2023	4	3	0	2	0	2	3
WV	2021	1	0	0	1	0	0	0
	2022	0	1	0	0	0	0	1
	2023	1	0	0	0	0	0	1
WY	2021	2	0	0	0	0	0	2
	2022	2	1	0	0	0	1	2
	2023	2	2	0	0	0	2	2
Totals	2021	228	20	13	44	0	0	191
	2022	191	27	4	28	0	18	168
	2023	168	171	1	22	0	90	226

Notes to Table No. 3:

- (1) Terminations include situations where the Development Agreement was terminated by DPF for cause.
- (2) Non-Renewals include situations where the Development Agreement expired.
- (3) Ceased Operations include situations where the Development Agreement was terminated mutually by DPF and the developer, as well as situations where the Development Agreement was amended to remove the applicable state from the development area.

ITEM 20 TABLE NO. 4
Status of Company-Owned Outlets
For years 2021, 2022, 2023

(1) State	(2) Year	(3) Outlets at Start of Year	(4) Outlets Opened	(5) Outlets Reacquired From Franchisee	(6) Outlets Closed	(7) Outlets Sold to Franchisee	(8) Outlets at End of the Year
AZ	2021	63	1	0	1	0	63
	2022	63	1	0	0	64	0
	2023	0	0	0	0	0	0
FL	2021	53	5	0	0	0	58
	2022	58	1	0	0	0	59
	2023	59	1	0	0	0	60
MD	2021	36	0	0	0	0	36
	2022	36	1	0	1	0	36
	2023	36	0	0	0	0	36
MI	2021	0	0	0	0	0	0
	2022	0	0	23	1	0	22
	2023	22	0	0	0	1	21
NV	2021	39	3	0	0	0	42
	2022	42	0	0	1	0	41
	2023	41	2	0	0	0	43
TX	2021	69	3	0	0	0	72
	2022	72	2	0	0	0	74
	2023	74	1	0	0	0	75
UT	2021	48	2	0	0	0	50
	2022	50	0	0	0	50	0
	2023	0	0	0	0	0	0
VA	2021	54	0	0	0	0	54
	2022	54	0	0	0	0	54
	2023	54	0	0	1	0	53
Totals	2021	362	14	0	1	0	375
	2022	375	5	23	3	114	286
	2023	286	4	0	1	1	288

ITEM 20 TABLE NO. 5
Projected Openings for the period January 1, 2024 to December 29, 2024.

(1) State	(2) Franchise Agreements Signed But Outlet Not Opened	(3) Projected New Franchised Outlet In The Next Fiscal Year	(4) Projected New Company- Owned Outlet In the Next Fiscal Year
AK	0	1	0
AL	2	8	0
AR	0	1	0
AZ	0	2	0
CA	1	5	0
CO	1	4	0
CT	0	0	0
DE	0	0	0
FL	3	20	0
GA	0	8	0
HI	0	1	0
IA	0	2	0
ID	0	1	0
IL	0	4	0
IN	1	7	0
KS	0	0	0
KY	1	7	0
LA	0	3	0
MA	1	4	0
MD	0	0	0
ME	0	0	0
MI	0	8	1
MN	0	2	0

(1) State	(2) Franchise Agreements Signed But Outlet Not Opened	(3) Projected New Franchised Outlet In The Next Fiscal Year	(4) Projected New Company- Owned Outlet In the Next Fiscal Year
MO	0	3	0
MS	0	1	0
MT	0	1	0
NC	0	5	0
ND	0	1	0
NE	1	1	0
NH	0	1	0
NJ	0	3	0
NM	0	0	0
NV	0	0	4
NY	0	2	0
OH	0	5	0
OK	0	4	0
OR	1	4	0
PA	0	8	0
RI	0	0	0
SC	1	7	0
SD	0	2	0
TN	0	9	0
TX	2	25	3
UT	1	4	0
VA	0	3	1
VT	0	1	0
WA	0	1	0
WI	0	1	0

(1) State	(2) Franchise Agreements Signed But Outlet Not Opened	(3) Projected New Franchised Outlet In The Next Fiscal Year	(4) Projected New Company-Owned Outlet In the Next Fiscal Year
WV	0	1	0
WY	0	0	0
GUAM	0	0	0
Total	16	181	9

A list of the names of all Domino’s Pizza store franchisees and the addresses and telephone numbers of their Domino’s Pizza Traditional Stores are listed as Exhibit B to this disclosure document. A list of the names of all Domino’s Pizza store franchisees and the addresses and telephone numbers of their Domino’s Pizza Non-Traditional Stores are listed as Exhibit B-1 to this disclosure document. A list of the names and last known home addresses and telephone numbers of franchisees (109) and developers (69) who had a franchise agreement terminated, cancelled, not renewed, or otherwise voluntarily or involuntarily ceased to do business under their agreements during the fiscal year that ended December 31, 2023 (including those who transferred their franchises) or who have not communicated with us within 10 weeks of our application date appear on Exhibit B-2. If you buy this franchise, your contact information may be disclosed to other buyers when you leave the franchise system.

Franchisee Confidentiality Clauses

We have not entered into agreements with confidentiality clauses that would prevent franchisees from discussing their experience with Domino's.

Trademark-Specific Franchisee Organizations

We sponsor the following advisory groups which meet at our headquarters in Ann Arbor, Michigan or other agreed upon locations to promote communications and enhance the relationship with Domino’s Pizza franchisees: Domino’s Marketing Advisory Council, Domino’s Technical Advisory Board, Domino’s Operations Advisory Counsel and Domino’s Supply Chain Advisory Committee. These advisory groups do not have separate websites.

The following independent franchisee organizations have asked to be included in this disclosure document:

Domino’s Franchisee Association
5150 Broadway Street #124
San Antonio, TX 78209
(210) 845 1072
Ken@dominosdfa.com
www.dominosdfa.com

Domino’s Franchisee Forum
3689 Open Parkway
Elgin, IL 60124
(847) 846-9491
reece@mmpizza.net

Item 21: Financial Statements

Attached as Exhibit C are the audited financial statements of DPF, which are comprised of the consolidated balance sheets as of December 31, 2023 and January 1, 2023. It also includes the consolidated statements of income, member's interest and cash flows for the three years that ended December 31, 2023.

As noted in Item 1, DPL will be providing required support and services to franchisees under a servicing agreement with DPF. Attached as Exhibit D are the audited financial statements of DPL as of December 31, 2023 and January 1, 2023 and for the three fiscal years that ended December 31, 2023. These financial statements are being provided for disclosure purposes only. DPL is not a party to the Franchise Agreement or Development Agreement we sign with franchisees nor does it guarantee our obligations under the Franchise Agreement or Development Agreement we sign with franchisees.

As noted in Item 1, certain entities affiliated with Domino's entered into the 2007 Securitization Transaction and several additional secured financing transactions subsequent to the 2007 Securitization Transaction (and may do other securitization/financing transactions in the future). Certain indirect subsidiaries of DPL, including DPF, have guaranteed the indebtedness incurred in connection with each of these transactions.

Item 22: Contracts

The following agreements are attached as exhibits to this disclosure document:

Traditional Store Standard Franchise Agreement – Exhibit E
Non-Traditional Store Franchise Agreement – Exhibit F
Development Agreement – Exhibit G
Domino's Pizza Help Desk Services Agreement – Exhibit H
Sale of Assets Agreement – Exhibit I
Domino's PULSE Software License Agreement – Exhibit J
Expiration of Franchise Agreement and Release – Exhibit K
Lease Rider – Exhibit L
Purchase Agreement Rider – Exhibit M
Domino's Pizza Online Ordering Franchisee Services Agreement – Exhibit P
Term Sheet – Exhibit Q
Global Positioning System Technology Platform Agreement – Exhibit R
Domino's Rider to Services Agreement – Exhibit S

**ADDENDUM TO THE
DOMINO'S PIZZA FRANCHISING LLC
MULTI-STATE DISCLOSURE DOCUMENT**

The following are additional disclosures to the Domino's Pizza Franchising LLC Multi-State Franchise Disclosure Document required by various state franchise laws. Each provision of these additional disclosures will not apply unless, with respect to that provision, the jurisdictional requirements of the applicable state franchise registration and disclosure law are met independently without reference to these additional disclosures.

State-Specific Requirements

NO WAIVER OR DISCLAIMER OF RELIANCE IN CERTAIN STATES:

1. The following provision applies only to franchisees and franchises that are subject to the state franchise registration/disclosure laws in California, Hawaii, Illinois, Indiana, Maryland, Michigan, Minnesota, New York, North Dakota, Rhode Island, South Dakota, Virginia, Washington, or Wisconsin:

No statement, questionnaire, or acknowledgement signed or agreed to by you in connection with the commencement of the franchise relationship shall have the effect of (i) waiving any claims under any applicable state franchise law, including fraud in the inducement, or (ii) disclaiming reliance on any statement made by us, any franchise seller, or any other person acting on our behalf. This provision supersedes any other term of any document executed in connection with the franchise.

CALIFORNIA:

DISCLOSURES REGARDING THE CALIFORNIA FAST FOOD ACT (CALIFORNIA ASSEMBLY BILL 1228)

1. The following language is added to the end of Item 1:

To the extent it is applicable, you must comply with California Assembly Bill 1228, codified at Cal. Lab. Code §§ 1474-1475 (the "Fast Food Act"). The Fast Food Act establishes: (a) a minimum wage of \$20 per hour for certain fast food restaurant employees effective April 1, 2024; and (b) a Fast Food Council (the "Council"), which is authorized to adopt fast food restaurant standards for wages, working hours and other working conditions, including health and safety standards and training. The Council has the authority, subject to state agency review, to annually raise the minimum wage by up to 3.5% from January 1, 2025 through December 31, 2028, depending on the increases in the cost of living from year to year.

2. The following language is added to the end of Items 5, 6, and 11:

We currently do not provide any training or assistance related to, or charge any initial or ongoing fees related to, the development or implementation of any standards, policies, or procedures that may be required under the Fast Food Act. It is solely your responsibility to determine whether the Fast Food Act applies to your

Store and, to the extent it does apply, to comply with the Fast Food Act when developing and constructing your restaurant, operating your Store, and training and supervising your employees.

3. The following language is added to the end of Item 7:

Since the Council has not, as of the date of this Disclosure Document, issued any standards under the Fast Food Act dealing with working conditions, we are unable to estimate the effects any such standards might have on the estimated initial investment.

4. The last sentence of Note (8) to the Item 7 charts, which corresponds to the “Additional Funds – 3 Months” line item, is hereby deleted in its entirety and replaced with the following:

Your costs will depend on the following factors: how much you follow your methods and procedures; your management skill, experience and business acumen; local economic conditions; the local market for your products and services; the prevailing wage rate (which will likely increase under the Fast Food Act); competition; and the sales level reached during the initial period.

ILLINOIS:

1. The following language is added to the table in Item 17 at the end of the Summary Section of Provision (v) entitled **Choice of Forum:**

(except for any claims arising under the Illinois Law).

2. The following language is added to the table in Item 17 at the end of the Summary Section of Provision (w) entitled **Choice of Law:**

(except for Illinois Law).

HAWAII:

THESE FRANCHISES WILL BE/HAVE BEEN FILED UNDER THE FRANCHISE INVESTMENT LAW OF THE STATE OF HAWAII. FILING DOES NOT CONSTITUTE APPROVAL, RECOMMENDATION OR ENDORSEMENT BY THE DIRECTOR OF REGULATORY AGENCIES OR A FINDING BY THE DIRECTOR OF REGULATORY AGENCIES THAT THE INFORMATION PROVIDED HEREIN IS TRUE, COMPLETE AND NOT MISLEADING.

THE FRANCHISE INVESTMENT LAW MAKES IT UNLAWFUL TO OFFER OR SELL ANY FRANCHISE IN THIS STATE WITHOUT FIRST PROVIDING TO THE PROSPECTIVE FRANCHISEE, OR SUBFRANCHISOR, AT LEAST SEVEN DAYS PRIOR TO THE EXECUTION BY THE PROSPECTIVE FRANCHISEE OF ANY BINDING FRANCHISE OR OTHER AGREEMENT, OR AT LEAST SEVEN DAYS PRIOR TO THE PAYMENT OF ANY

CONSIDERATION BY THE FRANCHISEE, OR SUBFRANCHISOR, WHICHEVER OCCURS FIRST, A COPY OF THE OFFERING CIRCULAR, TOGETHER WITH A COPY OF ALL PROPOSED AGREEMENTS RELATING TO THE SALE OF THE FRANCHISE.

THIS OFFERING CIRCULAR CONTAINS A SUMMARY ONLY OF CERTAIN MATERIAL PROVISIONS OF THE FRANCHISE AGREEMENT. THE CONTRACT OR AGREEMENT SHOULD BE REFERRED TO FOR A STATEMENT OF ALL RIGHTS, CONDITIONS, RESTRICTIONS AND OBLIGATIONS OF BOTH THE FRANCHISOR AND THE FRANCHISEE.

MARYLAND:

1. The following language is added to the end of the “Summary” sections of Item 17(c), entitled **Requirements for franchisee to renew or extend**, and Item 17(m), entitled **Conditions for franchisor approval of transfer**:

Any release required as a condition of renewal and/or assignment/transfer will not apply to any liability under the Maryland Franchise Registration and Disclosure Law.

2. The following language is added to the end of the “Summary” section of Item 17(g), entitled **“Cause” defined –defaults which cannot be cured**:

Termination upon insolvency might not be enforceable under federal bankruptcy law (11 U.S.C. Section 101 et seq.), but we will enforce it to the extent enforceable.

3. The following language is added to the end of the chart in Item 17:

You must bring any claims arising under the Maryland Franchise Registration and Disclosure Law within 3 years after the grant of the franchise.

MINNESOTA:

1. The following language is added to the table in Item 17 at the end of the Summary Section of Provision (v) entitled **Choice of Forum**:

Pursuant to Minn. Stat. 80C.21 and Minn. Rule Part 2860.4400J, this section shall not in any way abrogate or reduce any of your rights as provided for in Minnesota Statutes, Chapter 80C.

2. The following language is hereby added to the table in Item 17 at the end of the Summary Section of Provision (w) entitled **Choice of Law**:

With respect to franchises governed by Minnesota law, DPF will comply with Minn. Stat. Sec. 80C.14 Subds. 3, 4 and 5 which require, except in certain specified cases, that you be given 90 days' notice of termination (with 60 days' to cure) and 180 days' notice for non-renewal of the franchise agreement.

WASHINGTON:

1. The following additional disclosures are added to the franchise disclosure document:

In the event of a conflict of laws, the provisions of the Washington Franchise Investment Protection Act, Chapter 19.100 RCW will prevail.

RCW 19.100.180 may supersede the franchise agreement in your relationship with the franchisor including the areas of termination and renewal of your franchise. There may also be court decisions which may supersede the franchise agreement in your relationship with the franchisor including the areas of termination and renewal of your franchise.

In any arbitration or mediation involving a franchise purchased in Washington, the arbitration or mediation site will be either in the state of Washington, or in a place mutually agreed upon at the time of the arbitration or mediation, or as determined by the arbitrator or mediator at the time of arbitration or mediation. In addition, if litigation is not precluded by the franchise agreement, a franchisee may bring an action or proceeding arising out of or in connection with the sale of franchises, or a violation of the Washington Franchise Investment Protection Act, in Washington. A release or waiver of rights executed by a franchisee may not include rights under the Washington Franchise Investment Protection Act or any rule or order thereunder except when executed pursuant to a negotiated settlement after the agreement is in effect and where the parties are represented by independent counsel. Provisions such as those which unreasonably restrict or limit the statute of limitations period for claims under the Act, or rights or remedies under the Act such as a right to a jury trial, may not be enforceable.

Transfer fees are collectable to the extent that they reflect the franchisor’s reasonable estimated or actual costs in effecting a transfer.

Pursuant to RCW 49.62.020, a noncompetition covenant is void and unenforceable against an employee, including an employee of a franchisee, unless the employee’s earnings from the party seeking enforcement, when annualized, exceed \$100,000 per year (an amount that will be adjusted annually for inflation). In addition, a noncompetition covenant is void and unenforceable against an independent contractor of a franchisee under RCW 49.62.030 unless the independent contractor’s earnings from the party seeking enforcement, when annualized, exceed \$250,000 per year (an amount that will be adjusted annually for inflation). As a result, any provisions contained in the franchise agreement or elsewhere that conflict with these limitations are void and unenforceable in Washington.

RCW 49.62.060 prohibits a franchisor from restricting, restraining, or prohibiting a franchisee from (i) soliciting or hiring any employee of a franchisee of the same franchisor or (ii) soliciting or hiring any employee of the franchisor. As a result, any such provisions contained in the franchise agreement or elsewhere are void and unenforceable in Washington.

**ASSURANCE OF DISCONTINUANCE
STATE OF WASHINGTON**

To resolve an investigation by the State of Washington Attorney General’s Office, Domino’s Pizza LLC entered into an Assurance of Discontinuance (“AOD”) in October 2018 regarding provisions in its

franchise agreements that restricted a franchisee from soliciting and/or hiring the employees of other franchisees or Domino's. The position of the Attorney General's Office' was that such provisions violate Washington state and federal antitrust and unfair practices laws. While Domino's had previously notified its franchisees that it would no longer include such provisions in future franchise agreements, and would not enforce those provisions in any existing franchise agreements, Domino's agreed to include those commitments in the AOD. Therefore, as part of the AOD, Domino's agreed to no longer include the non-solicitation provisions in our franchise agreements and to not enforce those provisions in existing franchise agreements and notified our franchisees accordingly. Domino's did not admit any liability in the AOD and was not assessed any fines or other monetary penalties.

EXHIBIT A

LIST OF STATE AGENCIES/AGENTS FOR SERVICE OF PROCESS

**STATE AGENCIES/AGENTS
FOR SERVICE OF PROCESS**

Listed here are the names, addresses and telephone numbers of the state agencies having responsibility for the franchising disclosure/registration laws. We may not yet be registered to sell franchises in any or all of these states.

If a state is not listed, we have not appointed an agent for service of process in that state in connection with the requirements of the franchise laws. There may be states in addition to those listed below in which we have appointed an agent for service of process.

There also may be additional agents appointed in some of the states listed.

CALIFORNIA

Website: www.dfpi.ca.gov
Email: ask.DFPI@dfpi.ca.gov

Commissioner of Department of Financial
Protection & Innovation
Department of Financial Protection &
Innovation
Toll Free: 1 (866) 275-2677

Los Angeles

320 West 4th Street, Suite 750
Los Angeles, California 90013-2344
(213) 576-7500

Sacramento

2101 Arena Boulevard
Sacramento, California 95834
(866) 275-2677

San Diego

1455 Frazee Road, Suite 315
San Diego, California 92108
(619) 525-4233

San Francisco

One Sansome Street, Suite 600
San Francisco, California 94104-4428
(415) 972-8559

HAWAII

(for service of process)

Commissioner of Securities
Department of Commerce
and Consumer Affairs
Business Registration Division
335 Merchant Street, Room 203
Honolulu, Hawaii 96813
(808) 586-2722

(for other matters)

Commissioner of Securities
Department of Commerce
and Consumer Affairs
Business Registration Division
335 Merchant Street, Room 205
Honolulu, Hawaii 96813
(808) 586-2722

ILLINOIS

Illinois Attorney General
500 South Second Street
Springfield, Illinois 62706
(217) 782-4465

INDIANA

(for service of process)

Indiana Secretary of State
201 State House
200 West Washington Street
Indianapolis, Indiana 46204
(317) 232-6531

(state agency)

Indiana Secretary of State
Securities Division
Room E-111
302 West Washington Street
Indianapolis, Indiana 46204
(317) 232-6681

MARYLAND

(for service of process)

Maryland Securities Commissioner
at the Office of Attorney General-
Securities Division
200 St. Paul Place
Baltimore, Maryland 21202-2021
(410) 576-6360

(state agency)

Office of the Attorney General-
Securities Division
200 St. Paul Place
Baltimore, Maryland 21202-2021
(410) 576-6360

MICHIGAN

Michigan Attorney General's Office
Consumer Protection Division
Attn: Franchise Section
G. Mennen Williams Building, 1st Floor
525 West Ottawa Street
Lansing, Michigan 48933
(517) 335-7567

MINNESOTA

Commissioner of Commerce
Department of Commerce
85 7th Place East, Suite 280
St. Paul, Minnesota 55101
(651) 539-1500

NEW YORK

(for service of process)

Attention: New York Secretary of State
New York Department of State
One Commerce Plaza,
99 Washington Avenue, 6th Floor
Albany, New York 12231-0001
(518) 473-2492

(Administrator)

NYS Department of Law
Investor Protection Bureau
28 Liberty Street, 21st Floor
New York, New York 10005
(212) 416-8236

NORTH DAKOTA

(for service of process)

Securities Commissioner
North Dakota Securities Department
600 East Boulevard Avenue
State Capitol, 14th Floor, Dept. 414
Bismarck, North Dakota 58505-0510
(701) 328-4712

(state agency)

North Dakota Securities Department
600 East Boulevard Avenue, Suite 414
Bismarck, North Dakota 58505
(701) 328-2910

OREGON

Oregon Division of Financial Regulation
350 Winter Street NE, Suite 410
Salem, Oregon 97301
(503) 378-4140

RHODE ISLAND

Securities Division
Department of Business Regulations
1511 Pontiac Avenue
John O. Pastore Complex-Building 69-1
Cranston, Rhode Island 02920
(401) 462-9500

SOUTH DAKOTA

Division of Insurance
Securities Regulation
124 S. Euclid, Suite 104
Pierre, South Dakota 57501
(605) 773-3563

VIRGINIA

(for service of process)

Clerk, State Corporation Commission
1300 East Main Street
First Floor
Richmond, Virginia 23219
(804) 371-9733

(for other matters)

State Corporation Commission
Division of Securities and Retail Franchising
Tyler Building, 9th Floor
1300 East Main Street
Richmond, Virginia 23219
(804) 371-9051

WASHINGTON

(for service of process)

Director Department of Financial Institutions
Securities Division
150 Israel Road SW
Tumwater, Washington 98501
(360) 902-8760

(for other matters)

Department of Financial Institutions
Securities Division
P. O. Box 41200
Olympia, Washington 98504-1200
(360) 902-8760

WISCONSIN

(for service of process)

Administrator, Division of Securities
Department of Financial Institutions
4822 Madison Yards Way, North Tower
Madison, Wisconsin 53705
(608) 266-2139

(state administrator)

Division of Securities
Department of Financial Institutions
4822 Madison Yards Way, North Tower
Madison, Wisconsin 53705
(608) 266-9555

EXHIBIT B

LIST OF DOMINO'S PIZZA FRANCHISEES – TRADITIONAL

Exhibit B Traditional
as of December 31, 2023

Store State	Store	Franchisee	Area Type	Store Address	Store City	Store Zip	Store Phone
AK	19001	Dobb, Bryan W.		3024 Mt. View Drive	Anchorage	99501	(907) 258-3030
AK	19002	Dobb, Bryan W.		7731 E. Northern Lights Boulevard, Unit 270	Anchorage	99504	(907) 865-8999
AK	19003	Dobb, Bryan W.		601 W 36th Avenue, Box 8	Anchorage	99503	(907) 561-8166
AK	19008	Dobb, Bryan W.		11431 Business Boulevard	Eagle River	99577	(907) 726-5000
AK	19012	Dobb, Bryan W.		3805 Provider Drive	Elmendorf AFB	99506	(907) 337-3377
AK	19014	Dobb, Bryan W.		1731 E. Palmer - Wasilla Highway	Wasilla	99654	(907) 376-1000
AK	19015	Dobb, Bryan W.		317 104th Avenue	Anchorage	99515	(907) 345-3030
AK	19016	Dobb, Bryan W.		43981 Sterling Highway, Suite B	Soldotna	99669	(907) 600-4001
AK	19040	Dobb, Bryan W.		607 W. Willoughby Avenue	Juneau	99801	(907) 586-3030
AK	19041	Dobb, Bryan W.		2354 Mendenhall Loop Road #101	Juneau	99801	(907) 789-3300
AK	19050	Dobb, Bryan W.		410 Merhar Avenue	Fairbanks	99701	(907) 451-8201
AK	19051	Dobb, Bryan W.		3451 College Road	Fairbanks	99709	(907) 328-0809
AL	5308	Ford, Grant Forrester		376 Chesser Drive	Chelsea	35043	(205) 678-2007
AL	5313	May, Roy Jeffrey		25814 Canal Road, Suite #6	Orange Beach	36561	(251) 981-8880
AL	5316	Parris, Derek M.		110 5th Street East	Warrior	35180	(205) 590-3733
AL	5329	Parris, Derek M.		111 Railroad Avenue, Suite #1	Montevallo	35115	(205) 665-3232
AL	5331	May, Roy Jeffrey		1145 Gulf Shores Parkway	Gulf Shores	36542	(251) 968-4110
AL	5332	Dhedhi, Danish W.		8800 Highway 72 W	Madison	35758	(256) 830-8333
AL	5333	May, Roy Jeffrey		21545 Highway 59 South, Suite E	Robertsdale	36567	(251) 947-1033
AL	5362	Ford, Grant Forrester		75639 Alabama Highway 77	Lincoln	35096	(205) 763-3200
AL	5363	Pellegrino, Gina M.		25 Rumbling Waters Drive	Wetumpka	36092	(334) 514-8500
AL	5364	Orcutt, Michael L.		1413C Highway 280 Bypass	Phenix City	36867	(334) 732-0202
AL	5365	Darger, Guy		3979 Parkwood Road, Suite #101	Bessemer	35022	(205) 426-1131
AL	5367	Dawoud, Mohammed (David)		3421 South Shades Crest Road, Suite 119	Hoover	35244	(205) 847-5300
AL	5368	Dhedhi, Danish W.		5600 Highway 431 South	Brownsboro	35741	(256) 532-0100
AL	5369	Dhedhi, Danish W.		6360 Highway 53, Unit C	Harvest	35749	(256) 801-4499
AL	5370	Dhedhi, Danish W.		14451 US-231 431N, Unit 4	Hazel Green	35750	(334) 824-6900
AL	5371	Mueller, Glenn A.		924 Saraland Boulevard S	Saraland	36571	(251) 675-3030
AL	5374	Stearns, Wesley Allen		89 Marietta Road	Springville	35146	(659) 444-1203
AL	5375	Darger, Guy		1535 Forestdale Boulevard	Birmingham	35214	(205) 791-1400
AL	5376	Dhedhi, Danish W.		12009 Highway 231/431 N	Meridianville	35759	(256) 828-6655
AL	5379	Dhedhi, Danish W.		1842 Glenn Street SW	Decatur	35603	(256) 340-3400
AL	5380	Dhedhi, Danish W.		644A Jeff Road NW	Huntsville	35806	(256) 830-9100
AL	5383	Dhedhi, Danish W.		1812 Winchester Road NE	Huntsville	35811	(256) 859-8888
AL	5384	Darger, Guy		7709 Parkway Drive	Leeds	35094	(205) 699-2727
AL	5385	Dhedhi, Danish W.		5601 Highway 157	Cullman	35058	(256) 727-9393

Exhibit B Traditional
as of December 31, 2023

AL	5386	Darger, Guy		445 Main Street	Trussville	35173	(205) 655-9080
AL	5387	May, Roy Jeffrey		712 S. McKenzie Street	Foley	36535	(251) 970-1010
AL	5388	May, Roy Jeffrey		3099 Loop Road, Suite C	Orange Beach	36561	(251) 200-5600
AL	5389	Safadi, Walid J.		1098 Drive Martin Luther King Expressway	Andalusia	36420	(334) 427-1100
AL	5390	Staples, Charles Austin		125 Buck Creek Plaza	Alabaster	35007	(205) 621-1811
AL	5391	Hall, Zan R.		1411 Cardinal Street	Demopolis	36732	(334) 289-4044
AL	5394	Mueller, Glenn A.		7685 Moffett Road	Mobile	36618	(251) 649-1922
AL	5395	Dawoud, Mohammed (David)		1715 Highway 78 - C	Dora	35062	(205) 648-1648
AL	5398	Dhedhi, Danish W.		5019 Highway 31	Hanceville	35077	(256) 352-6116
AL	5800	Mueller, Glenn A.		2949 Saint Stephens Road	Pritchard	36612	(251) 457-3030
AL	5801	Orcutt, Michael L.		175 N. College Street	Auburn	36830	(334) 821-3030
AL	5802	Orcutt, Michael L.		1451 Gateway Drive, Suite A	Opelika	36801	(334) 749-7101
AL	5804	Hall, Zan R.		3039 Skyland Boulevard E.	E. Tuscaloosa	35405	(205) 553-0026
AL	5805	Hall, Zan R.		700 Chastain Boulevard	Glencoe	35905	(256) 269-1100
AL	5806	Safadi, Walid J.		705 Glover Avenue	Enterprise	36330	(334) 393-5505
AL	5807	May, Roy Jeffrey		2578 Douglas Avenue	Brewton	36426	(251) 241-6042
AL	5808	May, Roy Jeffrey		201 Chambers Drive, Suite G	Bay Minette	36507	(251) 239-8338
AL	5810	Orcutt, Michael L.		1709 Broad Avenue	Lanett	36863	(334) 721-0005
AL	5811	Longen, Jerry A.		2924 Ross Clark Circle	Dothan	36301	(334) 793-4062
AL	5812	Longen, Jerry A.		809 S. Eufaula Avenue	Eufaula	36027	(334) 203-7676
AL	5813	Longen, Jerry A.		2115 E. Main, Suite 1	Dothan	36301	(334) 793-4010
AL	5814	Longen, Jerry A.		118 Highway 231 South, Suite B	Ozark	36361	(334) 774-6767
AL	5815	Hall, Zan R.		2225 Summerfield Road	Selma	36701	(334) 875-8060
AL	5816	D'Andrea, Peter P.		10710 Chantilly Parkway	Montgomery	36117	(334) 659-1500
AL	5817	D'Andrea, Peter P.		2611 E. South Boulevard	Montgomery	36111	(334) 409-6555
AL	5818	Midgette, Evan James Jr.		400 Lay Dam Road	Clanton	35045	(205) 258-5090
AL	5819	Safadi, Walid J.		808 S. George Wallace Drive	Troy	36081	(334) 566-1234
AL	5820	D'Andrea, Peter P.		3131 Bell Road	Montgomery	36116	(334) 271-1320
AL	5821	D'Andrea, Peter P.		5338 Atlanta Highway	Montgomery	36109	(334) 271-6401
AL	5822	Dawoud, Mohammed (David)		1261 Military Street	S. Hamilton	35570	(205) 634-8400
AL	5825	D'Andrea, Peter P.		2650 Zeida Road	Montgomery	36107	(334) 263-6464
AL	5826	D'Andrea, Peter P.		164 North Memorial Drive	Prattville	36067	(334) 365-3777
AL	5828	D'Andrea, Peter P.		3525 Highway 14	Millbrook	36054	(334) 694-8080
AL	5829	Mueller, Glenn A.		2396 West Schilling Road, Suite B	Mobile	36695	(251) 666-5951
AL	5830	Dhedhi, Danish W.		1401 Woodmont Drive	Tuscumbia	35674	(256) 460-4100
AL	5831	Mueller, Glenn A.		1616 Government Street	Mobile	36604	(251) 476-2142
AL	5832	Mueller, Glenn A.		7449 Airport Boulevard, Suite E	Mobile	36608	(251) 633-2080

Exhibit B Traditional
as of December 31, 2023

AL	5833	Mueller, Glenn A.			5369A Highway 90 West	Mobile	36619	(251) 660-1434
AL	5834	Orcutt, Michael L.			855 Market Place	Alexander City	35010	(256) 329-2236
AL	5835	Twilley, Bradley			383 James Payton Boulevard	Sylacauga	35150	(256) 249-4333
AL	5836	Hall, Zan R.			503 North Carlisle	Albertville	35951	(256) 891-1010
AL	5837	Hall, Zan R.			102 N. McClesky Street	Boaz	35957	(256) 593-9790
AL	5838	Hall, Zan R.			1437 Gunter Avenue	Guntersville	35976	(256) 505-0505
AL	5840	Hall, Zan R.			415 15th Street	Tuscaloosa	35401	(205) 345-9600
AL	5841	Hall, Zan R.			350 McFarland Boulevard	Northport	35473	(205) 349-1441
AL	5842	Midgett, Evan James Jr.			4527 Valleydale Road	Birmingham	35243	(205) 991-0070
AL	5843	Dawoud, Mohammed (David)			3659 Lorna Road, Suite 163	Hoover	35216	(205) 985-4700
AL	5844	Dawoud, Mohammed (David)			269 Forest Road	Hueytown	35023	(205) 744-0900
AL	5845	Parris, Derek M.			5031 Ford Parkway	Bessemer	35020	(205) 428-6262
AL	5846	Hall, Steven D.			2451 Crossplex Boulevard, Suite 117	Birmingham	35208	(205) 407-8600
AL	5847	Hall, Steven D.			726 23rd Street South	Birmingham	35233	(205) 320-0220
AL	5848	Darger, Guy			1506 Montclair Road	Birmingham	35210	(205) 956-8300
AL	5849	Stephens, Tonya Renee			302 Highway 78	Jasper	35501	(205) 221-9090
AL	5850	Staples, Charles Austin			Lot 3 Beverly Drive	Calera	35040	(205) 690-8484
AL	5851	Darger, Guy			430 Green Springs Highway, Suite #14	Homewood	35209	(205) 916-0070
AL	5852	Ford, Grant Forrester			2304 Columbiana Road	Vestavia Hills	35216	(205) 823-1888
AL	5853	Ghabayen, Waleed			1710 Decatur Highway, Suite 1	Fultondale	35068	(205) 841-3700
AL	5854	Midgett, Evan James Jr.			2681 Pelham Parkway	Pelham	35124	(205) 663-9425
AL	5855	Hall, Zan R.			1015 W. Meighan Boulevard	Gadsden	35901	(256) 952-7500
AL	5856	Ghabayen, Waleed			1322 Main Street	Gardendale	35071	(205) 386-6677
AL	5857	Ford, Grant Forrester			709 Battle Street E	Talladega	35160	(256) 362-6800
AL	5858	Hall, Zan R.			964 Gilbert Ferry Road	Attalla	35954	(256) 538-1171
AL	5859	Hall, Billy James			2504 Stemley Bridge Road, Suite A	Pell City	35128	(205) 338-4780
AL	5860	Barger, Brian F.			405 Pelham Road S.	Jacksonville	36265	(256) 435-8200
AL	5863	Midgett, Evan James Jr.			4685 Highway 17	Helena	35080	(205) 621-4300
AL	5864	Hall, Zan R.			12001 Highway 43N, Suite C	Northport	35475	(205) 872-1800
AL	5865	Hall, Steven D.			9324 Parkway East	Birmingham	35215	(205) 703-9022
AL	5866	Hall, Zan R.			105 Sutton Bridge Road	Rainbow City	35906	(256) 442-1404
AL	5867	Dhedhi, Danish W.			602 11th Avenue NW	Arab	35016	(256) 586-2150
AL	5868	Dhedhi, Danish W.			413 3rd Street SW	Cullman	35055	(256) 739-6010
AL	5869	Dhedhi, Danish W.			813 S Broad Street	Scottsboro	35768	(256) 259-3080
AL	5870	Dhedhi, Danish W.			3319 Triana Boulevard SW	Huntsville	35805	(256) 536-4433
AL	5871	Dhedhi, Danish W.			401 Andrew Jackson Way NE	Huntsville	35801	(256) 539-5000
AL	5872	Dhedhi, Danish W.			11321 Memorial Parkway SE	Huntsville	35803	(256) 882-1080

Exhibit B Traditional
as of December 31, 2023

AL	5873	Dhedhi, Danish W.			4506 University Drive Nw	Huntsville	35816	(256) 830-2662
AL	5874	Dhedhi, Danish W.			2205 Mastin Lake Road Nw	Huntsville	35810	(256) 859-3777
AL	5875	Dhedhi, Danish W.			7200 Bailey Cove Road Se	Huntsville	35802	(256) 880-8700
AL	5876	Longen, Jerry A.			4388 Montgomery Highway	Dothan	36303	(334) 955-9300
AL	5877	Dhedhi, Danish W.			1836 Darby Drive	Florence	35630	(256) 766-6960
AL	5878	Dhedhi, Danish W.			4380 Highway 157	Florence	35633	(256) 764-7766
AL	5879	Mueller, Glenn A.			3871 Airport Boulevard, Suite 101	Mobile	36608	(251) 378-6000
AL	5880	Dhedhi, Danish W.			712 Avalon Avenue	Muscle Shoals	35661	(256) 381-4100
AL	5881	Dhedhi, Danish W.			14945 E. Limestone Road, Suite A	Harvest	35749	(256) 444-2700
AL	5882	Dhedhi, Danish W.			437 Hughes Road	Madison	35758	(256) 772-9000
AL	5883	Hall, Zan R.			301 Greenhill Boulevard NW	Fort Payne	35967	(256) 273-4440
AL	5884	Dawoud, Mohammed (David)			3135 Cahaba Heights Road, Suite 113	Vestavia	35243	(205) 972-1220
AL	5885	D'Andrea, Peter P.			3301 Mobile Highway	Montgomery	36108	(334) 284-4600
AL	5886	Dhedhi, Danish W.			119 US Highway 31 S.	Athens	35611	(256) 233-4700
AL	5887	Dhedhi, Danish W.			241 Highway 31 SW, Suite #30	Hartselle	35640	(256) 773-1444
AL	5888	Hall, Steven D.			101 8th Avenue SW	Childersburg	35044	(938) 777-0020
AL	5889	Dawoud, Mohammed (David)			8000 Liberty Parkway, Suite 108	Vestavia Hills	35242	(205) 580-1900
AL	5890	Hall, Zan R.			993 2nd Avenue East	Oneonta	35121	(205) 625-5000
AL	5891	Dhedhi, Danish W.			2934 Point Mallard Parkway, Unit A6	Decatur	35603	(256) 973-0101
AL	5892	Dhedhi, Danish W.			1820 6th Avenue SE	Decatur	35601	(256) 353-2888
AL	5893	Dhedhi, Danish W.			15379 Alabama Highway 24, Suite #10	Moulton	35650	(256) 719-0011
AL	5894	Darger, Guy			2446 Old Springville Road	Birmingham	35215	(205) 856-0030
AL	5895	May, Roy Jeffrey			6845 US Highway 90, Suite 109	Daphne	36526	(251) 626-8333
AL	5896	May, Roy Jeffrey			106 Plantation Pointe	Fairhope	36532	(251) 990-8747
AL	5897	Hall, Zan R.			13260 US Highway 411, Suite 100	Odenville	35120	(205) 629-2224
AL	5898	Hall, Zan R.			9730 Highway 69 South, Suite B	Tuscaloosa	35405	(205) 391-0052
AL	9400	Safadi, Walid J.			934 N. Daleville Avenue	Daleville	36322	(334) 751-2100
AL	9402	Dawoud, Mohammed (David)			1720 Hamric Drive E, Suite #1	Oxford	36203	(256) 831-9696
AL	9405	Dawoud, Mohammed (David)			5130-C McClellan Boulevard	Anniston	36206	(256) 530-4100
AL	9406	Dhedhi, Danish W.			7642 Highway 53	Toney	35773	(256) 970-2727
AL	9407	Donahoo, Camron Wesley			5285 US Highway 280, Suite 105	Birmingham	35242	(205) 408-8100
AL	9408	Dhedhi, Danish W.			143 Martin Road SW, Suite A	Huntsville	35824	(256) 270-4947
AL	9409	Darwin, Christopher D.			University Boulevard & 26th Avenue	Tuscaloosa	35404	(205) 632-0000
AL	9410	Orcutt, Michael L.			1100 S. College Street, Unit 108	Auburn	36830	(334) 539-4040
AL	9915	May, Roy Jeffrey			3947 State Highway 59, Suite 180	Gulf Shores	36542	(251) 228-5425
AL	9916	Hall, Zan R.			1499 E. Main Street	Rainsville	35986	(256) 273-7090
AR	5300	Hurteau/Prather, Art/Marty			1065 N. Garland Avenue	Fayetteville	72701	(479) 442-3600

Exhibit B Traditional
as of December 31, 2023

AR	5301	Hurteau/Prather, Art/Marty	2181 W. Sunset Avenue	Springdale	72746	(479) 756-0800
AR	5302	Landthrip, William Mack Jr.	105 Sandstone Drive	Van Buren	72956	(479) 474-7200
AR	5303	Hurteau/Prather, Art/Marty	2840 Bella Vista Way	Bella Vista	72714	(479) 876-7373
AR	5304	Hurteau/Prather, Art/Marty	2075 E. Main Street, Suite A	Siloam Springs	72761	(479) 524-0909
AR	5305	Hurteau/Prather, Art/Marty	2100 W. Hudson Road, Suite 7	Rogers	72756	(479) 631-2000
AR	5306	Medders, Brent J.	1812 N. Reynolds Road	Bryant	72022	(501) 847-6100
AR	5307	Powell, John M. Jr.	1436 Harrison Street	Batesville	72501	(870) 698-9099
AR	5310	Landthrip, William Mack Jr.	3701 Phoenix Avenue	Ft. Smith	72903	(479) 785-0841
AR	5311	Landthrip, William Mack Jr.	933 W. Center Street, Suite 1	Greenwood	72936	(479) 322-4122
AR	5312	Turner, Ty Michael	3006 I-55 Service Road	Marion	72364	(870) 609-4098
AR	5315	Barcomb, Calvin E.	2300 South Olive Street	Pine Bluff	71601	(870) 850-6700
AR	5317	Hurteau/Prather, Art/Marty	2350 E. Robinson Avenue	Springdale	72764	(479) 368-0123
AR	5318	Hurteau/Prather, Art/Marty	406 S. Walton Boulevard	Bentonville	72712	(479) 326-8787
AR	5319	Medders, Brent J.	740 South Salem, Suite 114	Conway	72034	(501) 450-3000
AR	5320	Holloway, Shane G.	903 ASU Boulevard	Beebe	72012	(501) 232-0430
AR	5321	Turner, Ty Michael	2702 Alexander Drive	Jonesboro	72401	(870) 201-8655
AR	5323	Hurteau/Prather, Art/Marty	3484 W. Wedington Drive	Fayetteville	72704	(479) 316-2600
AR	5324	Hurteau/Prather, Art/Marty	1227 W. Centeron Boulevard	Centeron	72719	(479) 354-5494
AR	5326	Turner, Ty Michael	1216 W. Keiser	Oseola	72370	(870) 385-5857
AR	5327	Benner, Lance L.	17200 Chenal Parkway	Little Rock	72223	(501) 821-2211
AR	5328	Medders, Brent J.	1813 N. 1Street Street	Jacksonville	72076	(501) 241-1900
AR	5330	Benner, Lance L.	11600 N. Rodney Parham Road, Suite B	Little Rock	72212	(501) 228-8111
AR	5334	Kern, Jason Thomas	4656 N. Highway 7, Suite J	Hot Springs Village	71909	(501) 915-9595
AR	5335	Schirmer, Phillip E.	2110 Higdon Ferry Road	Hot Springs	71913	(501) 525-7200
AR	5336	Medders, Brent J.	2744 Albert Pike Road, Suite A	Hot Springs	71913	(501) 620-4222
AR	5337	Medders, Brent J.	101 Camahan Drive	Maumelle	72113	(501) 851-1600
AR	5338	Mekonnen, Mac A.	318 3rd Street	Hope	71801	(870) 777-3400
AR	5340	Mekonnen, Mac A.	110 East Drive Martin Luther King Jr. Boulevard	Texarkana	71854	(870) 772-3030
AR	5341	Mekonnen, Mac A.	3214 Jefferson Avenue	Texarkana	71854	(870) 774-3030
AR	5342	Barcomb, Calvin E.	1300 Northwest Avenue	El Dorado	71730	(870) 862-0300
AR	5343	Holloway, Shane G.	13101 Highway 107	Sherwood	72120	(501) 392-6742
AR	5344	Turner, Ty Michael	100 Independence Drive	Trumann	72472	(870) 609-4098
AR	5345	Medders, Brent J.	1815 Old Morrilton Highway, Suite 101 & 102	Conway	72034	(501) 205-8899
AR	5346	Hurteau/Prather, Art/Marty	1001 E. Parkway	Russellville	72801	(479) 968-3030
AR	5347	Hurteau/Prather, Art/Marty	2800 SW 14th Street, Suite #2	Bentonville	72712	(479) 271-7070
AR	5348	Holloway, Shane G.	721 S. Second Street	Cabot	72023	(501) 605-9111
AR	5349	Medders, Brent J.	1412 Pine Street	Arkadelphia	71923	(870) 246-3131

Exhibit B Traditional
as of December 31, 2023

AR	5350	Turner, Ty Michael	1826 E. Johnson Avenue	Jonesboro	72401	(870) 935-6000
AR	5351	Hurteau/Prather, Art/Marty	207 Slack Street	Pea Ridge	72751	(479) 342-2010
AR	5352	Hurteau/Prather, Art/Marty	100 West New Hope Road	Rogers	72758	(479) 391-2005
AR	5353	Turner, Ty Michael	1405 C N. Missouri Street	West Memphis	72301	(870) 735-7600
AR	5354	Turner, Ty Michael	102 N. 14th Street	Paragould	72450	(870) 239-2166
AR	5355	Turner, Ty Michael	400 N. 6th Street	Blytheville	72315	(870) 762-1800
AR	5356	Turner, Ty Michael	2508 Stadium Boulevard	Jonesboro	72401	(870) 935-1133
AR	5357	Landthrip, William Mack Jr.	705 Highway 71 N	Alma	72921	(479) 370-3298
AR	5358	Hurteau/Prather, Art/Marty	1346 Highway 62 E.	Mountain Home	72653	(870) 424-6110
AR	5359	Benner, Lance L.	4905 John F. Kennedy Boulevard	North Little Rock	72116	(501) 834-2600
AR	5360	Cranford, Tera Renee	1645 E. Main Street	Magnolia	71753	(870) 234-4141
AR	5378	Holloway, Shane G.	3511 East Race Avenue, Suite 700	Searcy	72143	(501) 305-4511
AR	5396	Medders, Brent J.	8300 Stagecoach Road	Little Rock	72210	(501) 407-2722
AR	5397	Hurteau/Prather, Art/Marty	105 S. Dixieland #D	Lowell	72745	(479) 770-0044
AR	5399	Medders, Brent J.	208 E. Grand Avenue	Hot Springs	71901	(501) 623-5500
AR	9607	Hurteau/Prather, Art/Marty	1814 N. Crossover Road, Suite 1	Fayetteville	72701	(479) 445-6555
AR	9608	Hurteau/Prather, Art/Marty	320 West Main	Farmington	72730	(479) 300-6363
AR	9609	Medders, Brent J.	17310 I-30, Suite 1	Benton	72019	(501) 408-4688
AR	9610	Landthrip, William Mack Jr.	8500 Phoenix Avenue, Suite B	Fort Smith	72903	(479) 434-6996
AR	9611	West, Bryan Wayne	52 S. Broadview, Suite 101	Greenbrier	72058	(501) 679-3988
AR	9612	Hurteau/Prather, Art/Marty	992 E. Henri De Tonti Boulevard, Suite C	Tontitown	72762	(479) 927-6333
AR	9613	Davis, Curtis	836 N. Sebastian Street	West Helena	72390	(870) 330-7117
AR	9614	West, Bryan Wayne	1415 Hwy 25 North	Heber Springs	72543	(501) 429-2060
AR	9615	Benner, Lance L.	1402 Rebsamen Park Road	Little Rock	72202	(501) 500-5060
AR	9616	Benner, Lance L.	10815 Colonel Glenn Road, Suite 3500	Little Rock	72204	(501) 712-5711
AR	9617	Landthrip, William Mack Jr.	123 W Main Street	Clarksville	72830	(479) 802-5044
AR	9618	Cranford, Tera Renee	941 California Avenue SW, Suite B	Camden	71701	(870) 498-8600
AR	9619	Cranford, Tera Renee	1900 Martin Luther King Boulevard, Suite 100	Malvern	72104	(501) 458-4004
AR	9620	Turner, Ty Michael	701 N. Falls Boulevard	Wynne	72396	(870) 587-4229
AR	9621	Hurteau/Prather, Art/Marty	5092 W Northgate Road	Rogers	72758	(479) 802-4243
AR	9622	Hurteau/Prather, Art/Marty	900 Highway 62-65 North	Harrison	72601	(870) 302-3003
AR	9623	Varela, Mario	512 B Highway 425 South	Monticello	71655	(870) 662-6606
AR	9624	Landthrip, William Mack Jr.	4421 Grand Avenue	Fort Smith	72904	(479) 668-4878
AR	9625	Turner, Ty Michael	201 Deadrick Road, Suite 300	Forrest City	72335	(870) 494-3030
AR	9626	Holloway, Shane G.	1013 McQuay Avenue	Pochahontas	72455	(870) 637-0866
AR	9627	Holloway, Shane G.	1750 University Avenue, Suite 101	Morrilton	72110	(501) 289-6247
AR	9628	Holloway, Shane G.	1073 Main Street	Vilonia	72173	(501) 808-5050

Exhibit B Traditional
as of December 31, 2023

AZ	7534	Nelson, Robert E.	410 W. 5th Street	Safford	85546	(928) 428-5800
AZ	7542	Hishmeh, Tareq M.	1060 W. Beta Street #180	Green Valley	85614	(520) 320-6060
AZ	7544	Hishmeh, Tareq M.	8045 S. Rita Road	Tucson	85747	(520) 325-5050
AZ	7545	Ferdows, Farnad	518 West Riverside Drive	Parker	85344	(928) 669-3030
AZ	7548	Lasher, Justin C.	1240 East Deuce of Clubs	Show Low	85901	(928) 532-5534
AZ	7559	Hishmeh, Tareq M.	11445 E Via Linda	Scottsdale	85259	(480) 614-3077
AZ	7561	Hosseini, Dariush	1241 E Chandler Boulevard	Phoenix	85048	(480) 460-3332
AZ	7562	Ryneron, Shawn Paul	9141 W. Glendale Avenue, Suite #100	Glendale	85305	(623) 387-9080
AZ	7563	Ferdows, Farnad	3125 S. Alma School Road, Suite 1	Chandler	85248	(480) 786-3338
AZ	7564	Hosseini, Dariush	5310 S Superstition Mountain Drive	Gold Canyon	85118	(480) 300-6988
AZ	7566	McManus, Phillip	10719 W Indian School Road	Avondale	85392	(623) 877-3030
AZ	7568	McManus, Phillip	7606 W Indian School Road	Phoenix	85033	(623) 247-9030
AZ	7569	Hishmeh, Tareq M.	1945 W Durlap Avenue # 205	Phoenix	85021	(602) 749-0330
AZ	7570	Ferdows, Farnad	727 W Ray Road	Gilbert	85233	(877) 883-9643
AZ	7571	Ferdows, Farnad	1890 W. Highway 89A	Sedona	86336	(928) 203-0303
AZ	7572	Golembiowski, Sophie Paige	8248 W Deer Valley Road	Peoria	85382	(623) 376-0333
AZ	7573	McManus, Phillip	39506 N. Daisy Mountain Drive, Suite 120	Phoenix	85086	(623) 551-1515
AZ	7574	McManus, Phillip	8363 W. Van Buren Street, Building D Suite 2	Tolleson	85353	(480) 808-0885
AZ	7575	Ferdows, Farnad	4572 North Robert Road	Prescott Valley	86314	(928) 759-2333
AZ	7576	Golembiowski, Sophie Paige	3632 W Pinnacle Peak Road, Suite C	Glendale	85310	(623) 582-3332
AZ	7577	Ferdows, Farnad	1949 East Beverly Avenue, Suite C-106	Kingman	86409	(928) 681-3030
AZ	7578	McManus, Phillip	11345 W Buckeye Road, Suite B102	Avondale	85323	(623) 388-5900
AZ	7583	McManus, Phillip	7710 W Lower Buckeye Road, Suite 110	Phoenix	85043	(623) 936-9898
AZ	7584	Hosseini, Dariush	6170 S 51st Avenue, Suite 101	Laveen	85339	(602) 237-8300
AZ	7585	Ferdows, Farnad	452 W. Finnie Flat Road #B	Camp Verde	86322	(928) 554-0999
AZ	7587	McManus, Phillip	19445 W Indian School Road, Suite 101	Buckeye	85396	(480) 934-0120
AZ	7590	Kearns, David	1417 N Arizona Boulevard	Coolidge	85128	(435) 633-6211
AZ	7593	Ferdows, Farnad	13540 S Sunland Gin Road	Arizona City	85123	(520) 494-1010
AZ	7596	Hishmeh, Tareq M.	3071 W Hunt Highway	Queen Creek	85142	(480) 882-3232
AZ	7601	Hosseini, Dariush	3602 E Indian School Road	Phoenix	85018	(602) 957-8377
AZ	7602	Hosseini, Dariush	510 S Dobson Road	Mesa	85202	(480) 964-3030
AZ	7603	Hosseini, Dariush	681 E Apache Boulevard, Suite 104	Tempe	85281	(480) 968-5555
AZ	7604	Hishmeh, Tareq M.	1850 W Indian School Road	Phoenix	85015	(602) 285-3030
AZ	7605	Hosseini, Dariush	1635 E Baseline Road	Phoenix	85042	(602) 610-7699
AZ	7606	McManus, Phillip	6650 W Thomas Road	Phoenix	85033	(623) 247-3030
AZ	7607	Hishmeh, Tareq M.	10411 N 35th Avenue	Phoenix	85051	(602) 863-6883
AZ	7608	Hosseini, Dariush	1960 E Broadway Road	Mesa	85204	(480) 962-7500

Exhibit B Traditional
as of December 31, 2023

AZ	7610	Hishmeh, Tareq M.	4889 W. Ajo Way #101	Tucson	85757	(520) 704-6500
AZ	7611	Siegwald Harber, Stephanie Brooke	3510 W Bell Road, Suite 9	Phoenix	85308	(602) 547-3030
AZ	7612	Hosseini, Dariush	318 E Brown Road	Mesa	85201	(480) 835-6400
AZ	7613	McManus, Phillip	4284 W Thomas Road	Phoenix	85019	(602) 278-3030
AZ	7614	Ferdows, Farnad	1417 North Arizona Boulevard	Coolidge	85128	(520) 464-9628
AZ	7616	Hishmeh, Tareq M.	13843 N Tatum Boulevard, Suite 7	Phoenix	85032	(602) 996-3030
AZ	7617	Hishmeh, Tareq M.	1246 S Greenfield., Suite 100	Mesa	85206	(480) 993-2373
AZ	7618	Hishmeh, Tareq M.	8501 N 7th Street	Phoenix	85020	(602) 997-1616
AZ	7619	Hishmeh, Tareq M.	914 E Camelback Road	Phoenix	85014	(602) 264-3030
AZ	7620	Rynerson, Shawn Paul	12550 W Thunderbird Road, Suite 117	El Mirage	85335	(623) 876-9393
AZ	7621	Hishmeh, Tareq M.	901 E. Speedway Boulevard	Tucson	85719	(520) 792-5000
AZ	7623	Hishmeh, Tareq M.	1620 S. Craycroft Road	Tucson	85711	(520) 747-0550
AZ	7624	Hishmeh, Tareq M.	4390 N. 1Street Avenue	Tucson	85719	(520) 293-5990
AZ	7625	Hishmeh, Tareq M.	5460 E. Speedway Boulevard #B101	Tucson	85712	(520) 296-2333
AZ	7626	Hishmeh, Tareq M.	3682 W. Orange Grove Road	Tucson	85741	(520) 742-6111
AZ	7627	Hishmeh, Tareq M.	2624 E. 22nd Street	Tucson	85713	(520) 881-8700
AZ	7628	Hishmeh, Tareq M.	8486 E. Broadway	Tucson	85710	(520) 296-3111
AZ	7629	Hishmeh, Tareq M.	8615 E. Golf Links Road	Tucson	85730	(520) 721-8118
AZ	7630	Todd, Virgil L.	710 E 32nd Street	Yuma	85365	(928) 344-0555
AZ	7631	Todd, Virgil L.	712 S. 4th Avenue	Yuma	85364	(928) 782-7561
AZ	7632	Hishmeh, Tareq M.	6450 S. 6th Avenue	Tucson	85706	(520) 889-9988
AZ	7633	Hishmeh, Tareq M.	2080 W. Orange Grove Road, Suite 120	Tucson	85704	(520) 742-7700
AZ	7634	Hishmeh, Tareq M.	3312 South 6th Avenue	Tucson	85713	(520) 447-8000
AZ	7635	Hishmeh, Tareq M.	6875 E. Sunrise Drive, Suite 101	Tucson	85750	(520) 577-9595
AZ	7636	Hishmeh, Tareq M.	3118 E. Fort Lowell Road	Tucson	85716	(520) 327-9533
AZ	7637	Hishmeh, Tareq M.	1402 W. Street Marys Road	Tucson	85745	(520) 884-1400
AZ	7638	Todd, Virgil L.	1701 South Avenue B, Suite #104	Yuma	85364	(928) 783-3030
AZ	7640	Hosseini, Dariush	709 E Guadalupe Road	Tempe	85283	(480) 491-3030
AZ	7642	Hishmeh, Tareq M.	5833 N 35th Avenue	Phoenix	85017	(602) 249-3030
AZ	7643	Hosseini, Dariush	2442 E Thomas Road	Phoenix	85016	(602) 957-6677
AZ	7644	Siegwald Harber, Stephanie Brooke	13706 N 51st Avenue	Glendale	85304	(602) 439-3030
AZ	7645	Hosseini, Dariush	930 W Broadway Road	Tempe	85282	(480) 894-6600
AZ	7646	Hosseini, Dariush	4505 E Mckellips Road	Mesa	85215	(480) 882-0975
AZ	7647	Hishmeh, Tareq M.	3329 E Bell Road	Phoenix	85032	(602) 482-3030
AZ	7648	Hosseini, Dariush	3402 S McClintock Drive	Tempe	85282	(480) 887-9400
AZ	7649	Rynerson, Shawn Paul	6766 W Glendale Avenue, Suite 105	Glendale	85303	(623) 934-3030
AZ	7650	Rynerson, Shawn Paul	8940 W Bell Road, Suite 102	PEORIA	85382	(623) 444-2993

Exhibit B Traditional
as of December 31, 2023

AZ	7651	Hosseini, Dariush			2819 N Central Avenue	Phoenix	85004	(602) 234-3030
AZ	7652	Hishmeh, Tareq M.			754 S Val Vista Drive, Suite 103	Gilbert	85296	(480) 926-3030
AZ	7656	Rynerson, Shawn Paul			9827 W. Grand Avenue, Suite E	Sun City	85351	(623) 933-0200
AZ	7657	Hishmeh, Tareq M.			6929 N Hayden Road	Scottsdale	85250	(480) 951-3700
AZ	7658	Hosseini, Dariush			1145 S Mesa Drive	Mesa	85210	(480) 844-9300
AZ	7659	Hosseini, Dariush			2902 N 68th Street	Scottsdale	85251	(602) 952-9300
AZ	7660	Campos, Kelly Ramos			1529 S. Milton Road	Flagstaff	86001	(928) 779-3686
AZ	7661	Hosseini, Dariush			2119 N Power Road, Suite 102	Mesa	85215	(480) 641-3030
AZ	7662	Stegwald Harber, Stephanie Brooke			7440 W Cactus Road, Suite A2	Peoria	85381	(623) 878-3030
AZ	7663	Hosseini, Dariush			324 E Southern Avenue	Phoenix	85040	(602) 268-3030
AZ	7664	Campos, Kelly Ramos			2577 E. 7Th Avenue	Flagstaff	86004	(928) 527-0797
AZ	7665	Hosseini, Dariush			12020 S Warner Elliot Loop	Phoenix	85044	(480) 893-9300
AZ	7666	Kearns, David			624 Elm Street	Page	86040	(928) 612-1211
AZ	7667	Hosseini, Dariush			7908 E Chaparral Road	Scottsdale	85250	(480) 947-3030
AZ	7668	Hishmeh, Tareq M.			5102 W Northern Avenue	Glendale	85301	(623) 939-3030
AZ	7669	McManus, Phillip			14175 W Indian School Road, Ste A3	Goodyear	85395	(623) 935-5000
AZ	7670	Ferdows, Farnad			104 W Florence Boulevard	Casa Grande	85122	(520) 836-1111
AZ	7672	Hosseini, Dariush			3875 W Ray Road, Suite 10	Chandler	85226	(480) 786-3030
AZ	7673	Hosseini, Dariush			10826 E Apache Trail	Apache Junction	85120	(480) 380-3030
AZ	7674	Hosseini, Dariush			25 W Warner Road	Chandler	85225	(480) 899-3030
AZ	7675	Rynerson, Shawn Paul			9845 W Bell Road	Sun City	85351	(480) 841-8887
AZ	7676	Hishmeh, Tareq M.			3040 W. Valencia	Tucson	85746	(520) 573-3030
AZ	7677	Rynerson, Shawn Paul			15332 W Bell Road, Suite 129	Surprise	85374	(623) 546-2300
AZ	7679	Hishmeh, Tareq M.			7045 N 35th Avenue	Phoenix	85051	(602) 841-3030
AZ	7680	Hishmeh, Tareq M.			23 N. Garden Street	Sierra Vista	85635	(520) 458-3030
AZ	7681	Hishmeh, Tareq M.			3670 E. Fry Boulevard	Sierra Vista	85635	(520) 458-5000
AZ	7682	Ferdows, Farnad			491 N. Lake Havasu Avenue	Lake Havasu City	86403	(928) 680-1800
AZ	7683	Ferdows, Farnad			2150 Highway 95	Bullhead City	86442	(928) 758-3030
AZ	7684	Hishmeh, Tareq M.			100 W. White Park Drive	Nogales	85621	(520) 800-6400
AZ	7685	Ferdows, Farnad			223 N. Cortez Street	Prescott	86301	(928) 778-3030
AZ	7686	Hishmeh, Tareq M.			10420 La Canada Drive, Suite 140	Oro Valley	85737	(520) 797-3030
AZ	7688	Hosseini, Dariush			6920 E Baseline Road	Mesa	85209	(480) 924-3030
AZ	7689	Todd, Virgil L.			3310 S. Ave 8E, Unit 4	Yuma	85365	(928) 259-7111
AZ	7690	Hishmeh, Tareq M.			20024 N. John Wayne Parkway	Marcopa	85139	(520) 568-3030
AZ	7691	Todd, Virgil L.			11361 Foothills Boulevard, Suite #4	Yuma	85367	(928) 342-3400
AZ	7692	McManus, Phillip			5030 W McDowell Road, Suite 51	Phoenix	85035	(602) 233-2323
AZ	7693	Hishmeh, Tareq M.			751 E Union Hills Drive, Suite A1	Phoenix	85024	(602) 788-7300

Exhibit B Traditional
as of December 31, 2023

AZ	7694	Hishmeh, Tareq M.			7730 N. Cortaro Road, Suite 101	Tucson	85743	(520) 579-3030
AZ	9007	Ferdows, Farnad			3469 Maricopa Avenue	Lake Havasu City	86403	(928) 392-0002
AZ	9200	Ferdows, Farnad			1021 North Highway 89, Suite 103	Chino Valley	86323	(928) 636-6000
AZ	9201	Hishmeh, Tareq M.			20928 E Heritage Loop Road, Suite 103	Queen Creek	85142	(480) 888-8860
AZ	9202	Hishmeh, Tareq M.			7205 S Power Road, Suite 103	Queen Creek	85142	(480) 988-2843
AZ	9203	Ferdows, Farnad			4508 S. Highway 95, Unit I	Fort Mohave	86426	(928) 704-4700
AZ	9204	Hishmeh, Tareq M.			12060 N. Thornydale Road, Suite 108	Marana	85658	(520) 797-3330
AZ	9205	McManus, Phillip			6213 S. Miller Road, Suite 102	Buckeye	85326	(623) 327-1111
AZ	9206	Hishmeh, Tareq M.			15318 N Oracle Road, Suite 140	Tucson	85739	(520) 323-3030
AZ	9208	McManus, Phillip			833 S Cotton Lane	Goodyear	85338	(480) 462-0300
AZ	9210	Ferdows, Farnad			1100 East State Route 260, Suite C-3	Cottonwood	86326	(928) 634-7500
AZ	9211	Ferdows, Farnad			4085 South Gilbert Road, Suite 7	Chandler	85249	(480) 659-4555
AZ	9212	Hishmeh, Tareq M.			1605 S Gilbert Road, Suite 105	Gilbert	85295	(480) 445-9078
AZ	9213	Siegwald Harber, Stephanie Brooke			32409 North Scottsdale Road, Suite 105	Scottsdale	85266	(480) 595-6000
AZ	9214	Hishmeh, Tareq M.			14601 Scottsdale Road	Scottsdale	85254	(520) 217-2323
AZ	9216	Hishmeh, Tareq M.			13240 North 7th Street	Phoenix	85022	(480) 712-3444
CA	7054	Walter, Eldon R.			212 Turnwater Boulevard	Turnwater	98512	(360) 919-0000
CA	7330	Hosseini, Dariush			12901 Sherman Way, Unit C	North Hollywood	91605	(818) 759-0000
CA	7389	Syriani, Joseph			40404 California Oaks Road	Murrieta	92562	(951) 696-0117
CA	7393	Hosseini, Dariush			2559-C Rosamond Boulevard	Rosamond	93560	(661) 256-4200
CA	7394	Mollaghaseimi-Tabrizi, Gholamhossein			8022 Limonite Avenue, Unit 107	Riverside	92509	(951) 685-7777
CA	7417	Miessner, Eric P.			1332 Main Street	Ramona	92065	(760) 788-6644
CA	7419	Tapia, Fernando			77-920 Country Club Drive, Suite 6-6	Palm Desert	92211	(760) 200-0802
CA	7437	Shariff, Sammy M.			8300 Brentwood Boulevard, Suite D	Brentwood	94513	(925) 240-8555
CA	7476	Gobrial, Nehad E.			27131 Aliso Creek Road, Suite 145	Aliso Viejo	92656	(949) 389-0333
CA	7479	Hosseini, Dariush			12265 Scripps Poway Parkway B-105	Poway	92064	(858) 549-4343
CA	7492	Hosseini, Dariush			1096 Cardiff Street	San Diego	92114	(619) 460-7000
CA	7493	Hishmeh, Tareq M.			1401 Highway 46, Suite A	Wasco	93280	(661) 758-3030
CA	7494	La Mountain, Doyle			26517 State Highway 18	Rim Forest	92378	(909) 336-1255
CA	7701	Hosseini, Dariush			5185 College Avenue	San Diego	92115	(619) 287-9050
CA	7702	Tobie, Pamela A.			3520 Ashford, Suite C	San Diego	92111	(658) 292-6991
CA	7703	Hosseini, Dariush			702 Highland Avenue	National City	91950	(619) 474-8511
CA	7704	Miessner, Eric P.			936 Broadway	El Cajon	92021	(619) 442-9245
CA	7705	Hosseini, Dariush			1104 E. Washington Avenue	El Cajon	92019	(619) 444-2171
CA	7707	Hosseini, Dariush			4013 West Point Loma Boulevard	San Diego	92110	(619) 224-2445
CA	7708	Hosseini, Dariush			10251 Mast Boulevard, Suite A	Santee	92071	(619) 449-5400
CA	7709	Hosseini, Dariush			2110 Birch Road, Suite #105	Chula Vista	91915	(619) 745-4334

Exhibit B Traditional
as of December 31, 2023

CA	7710	Miessner, Eric P.	4120 Clairemont Mesa Boulevard, Suite 102	San Diego	92117	(858) 483-6700
CA	7711	Hosseini, Dariush	1330 Orange Avenue	Coronado	92118	(619) 437-4241
CA	7712	Hosseini, Dariush	1307 Imperial Beach Boulevard	Imperial Beach	91932	(619) 575-2226
CA	7713	Tobie, Pamela A.	4701 El Cajon Boulevard	San Diego	92115	(619) 281-1975
CA	7714	Tobie, Pamela A.	10789 Tierra Santa Boulevard, Suite 111	San Diego	92124	(858) 560-6112
CA	7715	Hosseini, Dariush	10606 Camino Ruiz #9	San Diego	92126	(858) 566-9480
CA	7716	Hosseini, Dariush	7660 D Fay Street	La Jolla	92037	(858) 257-4114
CA	7717	Miessner, Eric P.	10135 Maine Avenue	Lakeside	92040	(619) 561-3500
CA	7718	Tobie, Pamela A.	1925 El Cajon Boulevard	San Diego	92104	(619) 294-4570
CA	7719	Tobie, Pamela A.	7960 University Avenue, Suite 200	La Mesa	91941	(619) 589-6313
CA	7720	La Mountain, Doyle	1151 Calimesa Boulevard	Calimesa	92320	(909) 446-0000
CA	7721	Hosseini, Dariush	13857 Carmel Valley Road, Suite A	San Diego	92130	(858) 324-5200
CA	7722	Hosseini, Dariush	5073 Federal Boulevard	San Diego	92102	(619) 530-0880
CA	7723	Hosseini, Dariush	1350 6th Avenue, Suite #185	San Diego	92101	(619) 238-2323
CA	7724	Hosseini, Dariush	380 3rd Avenue	Chula Vista	91910	(619) 585-1212
CA	7725	Mollaghasemi-Tabrizi, Gholamhossein	2915 Van Buren Boulevard, Suite J-2	Riverside	92503	(951) 359-4444
CA	7726	Miessner, Eric P.	1787 E. Main Street	El Cajon	92021	(619) 444-3030
CA	7727	Hosseini, Dariush	756 Denney Road, Suite 202	San Diego	92154	(619) 614-2600
CA	7728	Hishmeh, Tareq M.	1768 E. 14th Street	San Leandro	94577	(510) 351-3301
CA	7729	Hishmeh, Tareq M.	529 Ventura Street	Filmore	93015	(805) 524-1600
CA	7730	La Mountain, Doyle	203 South Riverside Avenue	Rialto	92376	(909) 793-5679
CA	7731	Hishmeh, Tareq M.	1609 Cecil Avenue	Delano	93215	(661) 725-0770
CA	7732	Hosseini, Dariush	1021 E. Bobier Drive	Vista	92084	(760) 940-0904
CA	7733	Taylor, Joney E.	3559 W. Ramsey Street, Suite B	Banning	92220	(951) 849-7770
CA	7734	Hishmeh, Tareq M.	2408 A Stearns Street	Simi Valley	93063	(805) 522-9022
CA	7735	La Mountain, Doyle	461 W. Base Lime Road	Rialto	92376	(909) 874-5980
CA	7736	La Mountain, Doyle	229 W. Valley Boulevard	Colton	92324	(909) 383-8080
CA	7737	Hosseini, Adam	12411 Limonite Avenue, Suite 640	Eastvale	91752	(951) 727-8211
CA	7738	Tapia, Fernando	16863 Foothill Boulevard	Fontana	92335	(909) 823-4401
CA	7739	Hosseini, Dariush	9885 Central Avenue #C	Montclair	91763	(909) 447-6730
CA	7740	Manos, Anthony P.	8307 S. La Cienega Boulevard, Suite B	Inglewood	90301	(424) 426-3100
CA	7741	Hosseini, Dariush	6401 Platt Avenue #7	West Hills	91307	(818) 999-3030
CA	7742	Shehadeh, Issa J.	861 Gray Avenue, Suite A	Yuba City	95991	(530) 673-3131
CA	7743	Patibandla Rao, Malli	1017 Fair Oaks Avenue	South Pasadena	91030	(626) 385-6500
CA	7744	Manos, Anthony P.	1621 W. Chapman Avenue	Orange	92868	(714) 978-9711
CA	7745	Manos, Anthony P.	2221 #B Palo Verde Avenue	Long Beach	90815	(562) 594-4506
CA	7746	Manos, Anthony P.	1383 S. Diamond Bar Boulevard	Diamond Bar	91765	(909) 861-9606

Exhibit B Traditional
as of December 31, 2023

CA	7747	Manos, Anthony P.			11391 Long Beach Boulevard #A-7	Lynwood	90262	(310) 604-1299
CA	7748	Hosseini, Dariush			10068 Arrow Highway	Rancho Cucamonga	91730	(909) 987-8000
CA	7749	La Mountain, Doyle			33562 Yucaipa Boulevard	Yucaipa	92399	(909) 790-2903
CA	7750	Casey, Shane B.			650 Douglas Drive, Suite 104	Oceanside	92058	(760) 439-0500
CA	7751	Hosseini, Dariush			301 Mission Avenue #106	Oceanside	92054	(760) 439-5440
CA	7752	Kraniger, Mark J.			1502 N. El Camino Real	San Clemente	92672	(949) 498-9002
CA	7753	Syriani, Joseph			410-A West Felicita Avenue	Escondido	92025	(760) 747-7300
CA	7754	Syriani, Joseph			120 E. Lincoln Avenue, Suite A	Escondido	92026	(760) 480-0800
CA	7755	Hosseini, Dariush			8746 Baseline Road	Rancho Cucamonga	91701	(951) 231-3700
CA	7756	Hosseini, Dariush			2858 Thunder Drive	Oceanside	92056	(760) 941-8333
CA	7757	Hosseini, Dariush			805 W. San Marcos Boulevard	San Marcos	92078	(760) 471-1055
CA	7758	Verano, Gerald Dela Rosa			2260 B Grass Valley Highway	Auburn	95603	(530) 325-0330
CA	7759	Hishmeh, Tareq M.			1703 N. 11th Avenue	Hanford	93230	(559) 582-5050
CA	7760	DeGrandis, Greg			561 North I Street	Reedley	93654	(559) 551-2700
CA	7761	DeGrandis, Greg			1555 N. Farmersville Boulevard	Farmersville	93223	(559) 838-3177
CA	7762	Patibandla Rao, Malli			4080 W. Shaw Avenue	Fresno	93722	(559) 390-0588
CA	7763	Patibandla Rao, Malli			3005 W. Bullard Avenue	Fresno	93711	(559) 229-1515
CA	7764	Iqbal, Ali Hassan			728 Geary Street	San Francisco	94109	(415) 776-0400
CA	7765	Vizzolini, Matt J.			424 E Tulare Avenue	Tulare	93274	(559) 686-8583
CA	7766	Kraniger, Mark J.			13728 Amar Road	La Puente	91746	(626) 699-2001
CA	7767	Weinsoff, Jack M.			2405 Michael Drive	Newbury Park	91320	(805) 499-0681
CA	7768	Hishmeh, Tareq M.			938 West Henderson Avenue	Porterville	93257	(559) 784-4040
CA	7769	Hishmeh, Tareq M.			1307 E. Houston	Visalia	93292	(559) 732-4040
CA	7770	Mollaghasemi-Tabrizi, Gholamhossein			2306 Brundage Lane	Bakersfield	93304	(661) 323-3030
CA	7771	Manos, Anthony P.			5685 N. Paramount Boulevard	Long Beach	90805	(562) 270-7055
CA	7772	Hosseini, Adam			1180 Hamner Avenue, Suite C	Norco	92860	(951) 734-2222
CA	7773	Iqbal, Ali Hassan			504 San Ramon Valley Boulevard	Danville	94526	(925) 855-9400
CA	7774	Tapia, Fernando			5024 Ball Road	Cypress	90630	(714) 761-0606
CA	7775	Hosseini, Dariush			885 West Avenue K	Lancaster	93534	(661) 948-0991
CA	7776	Hosseini, Dariush			602 E. Palmdale Boulevard	Palmdale	93550	(661) 272-0033
CA	7777	Hosseini, Dariush			39904 10th Street West, Suite C	Palmdale	93551	(661) 554-4040
CA	7778	Brumleve, Dan T.			901 Sunvalley Boulevard, Suite 101	Concord	94520	(925) 826-5040
CA	7779	Tapia, Fernando			8682 Beach Boulevard #103 & 104	Buena Park	90620	(714) 761-6333
CA	7780	Mollaghasemi-Tabrizi, Gholamhossein			2651 Oswell, Suite C	Bakersfield	93306	(661) 872-4321
CA	7781	Mollaghasemi-Tabrizi, Gholamhossein			1904 North Chester Avenue	Bakersfield	93308	(661) 399-1212
CA	7783	DeGrandis, Greg			257 Academy Avenue	Sanger	93657	(559) 272-2444
CA	7784	Patibandla Rao, Malli			11674 Ventura Boulevard	Studio City	91604	(818) 980-1999

Exhibit B Traditional
as of December 31, 2023

CA	7785	Tapia, Fernando			12693 Main Street, Suite 240	Hesperia	92345	(760) 983-4100
CA	7786	DeGrandis, Greg			1055 Sperry Avenue, Suite 2	Patterson	95363	(209) 683-1333
CA	7787	Hosseini, Dariush			6846 Reseda Boulevard	Reseda	91335	(818) 996-7996
CA	7789	Patibandla Rao, Malli			1007 Truman Street	San Fernando	91340	(818) 898-3003
CA	7790	Elyasi, Mohsen			1101 N. Main Street	Salinas	93906	(831) 424-3535
CA	7791	Patibandla Rao, Malli			8350 Garvey Avenue #B	Rosemead	91770	(626) 288-3030
CA	7792	Patibandla Rao, Malli			348 W. Huntington Drive	Monrovia	91016	(626) 303-2655
CA	7793	Cuesta, Jose I.			9448 E. Slauson Avenue	Pico Rivera	90660	(562) 942-8303
CA	7795	Manos, Anthony P.			2527 S. San Pedro Street	Los Angeles	90011	(323) 886-3900
CA	7796	Hosseini, Dariush			20905 Roscoe Boulevard	Canoga Park	91304	(747) 248-0810
CA	7797	Verano, Gerald Dela Rosa			113 Neal Street	Grass Valley	95945	(530) 270-0333
CA	7800	Patibandla Rao, Malli			5051 Auburn Boulevard, #B-100	Sacramento	95841	(916) 348-4065
CA	7801	Manos, Anthony P.			2803 S. Figueroa Street	Los Angeles	90007	(213) 746-9999
CA	7802	Hosseini, Dariush			1371 Westwood Boulevard	Los Angeles	90024	(310) 824-5000
CA	7803	Hosseini, Dariush			2484 Lincoln Boulevard	Venice	90291	(310) 821-6656
CA	7804	Patibandla Rao, Malli			902 N. La Cienega Boulevard	Los Angeles	90069	(310) 855-1899
CA	7805	Hosseini, Dariush			4238 S. Sepulvada Boulevard	Culver City	90230	(310) 839-0999
CA	7806	Hosseini, Dariush			10616 W. Pico Boulevard	Los Angeles	90064	(310) 839-0800
CA	7807	Manos, Anthony P.			15500 Paramount Boulevard	Paramount	90723	(562) 408-1531
CA	7808	Hosseini, Dariush			18957 Ventura Boulevard	Tarzana	91356	(818) 996-9690
CA	7809	Hamill, R. Brent			4257 W. 3rd Street	Los Angeles	90020	(213) 385-3888
CA	7810	Hishmeh, Tareq M.			431 N Ojai Road #D	Santa Paula	93060	(805) 933-2771
CA	7813	Manos, Anthony P.			5538 Del Amo Boulevard	Lakewood	90713	(562) 804-4637
CA	7814	La Mountain, Doyle			1055 Parkford Drive	Redlands	92373	(909) 335-2500
CA	7815	Hosseini, Dariush			21001 Sherman Way #16	Canoga Park	91303	(818) 347-6600
CA	7816	Hishmeh, Tareq M.			1808 Cliff Drive	Santa Barbara	93109	(805) 564-4303
CA	7817	Tapia, Fernando			10948 E. Imperial Highway #104	Norwalk	90650	(562) 864-9951
CA	7818	Behm, Nikita Spiroff			110 W. Foothill Boulevard	Glendora	91740	(626) 914-3881
CA	7820	La Mountain, Doyle			24986 Third Street	San Bernardino	92410	(909) 884-6421
CA	7821	La Mountain, Doyle			1644 E. Highland Avenue, Suite 101	San Bernardino	92404	(909) 881-2521
CA	7822	Hishmeh, Tareq M.			665 E. Los Angeles Avenue #G	Simi Valley	93065	(805) 527-7493
CA	7823	Patibandla Rao, Malli			413 W. Las Tunas Drive	San Gabriel	91776	(626) 287-0901
CA	7824	Manos, Anthony P.			5707 Pacific Boulevard, Unit A	Huntington Park	90255	(323) 589-7374
CA	7825	Behm, Timothy			1600 W Olive Avenue	Burbank	91506	(818) 841-8433
CA	7826	Manos, Anthony P.			9353 Alondra Boulevard	Bellflower	90706	(562) 920-8353
CA	7827	Manos, Anthony P.			1360 N. Avalon Boulevard	Wilmington	90744	(310) 513-8040
CA	7828	Ferdows, Farnad			2712 Foothill Boulevard, Units #B & C	La Crescenta	91214	(818) 957-8333

Exhibit B Traditional
as of December 31, 2023

CA	7829	DeGrandis, Greg	1290 W. Colony Boulevard, Suite 140	Ripon	95366	(209) 255-0300
CA	7830	Khazan, Houman	21172 Beach Boulevard	Huntington Beach	92648	(714) 960-6511
CA	7831	Ferdows, Farnad	17421 Beach Boulevard	Huntington Beach	92647	(714) 841-3112
CA	7832	Ferdows, Farnad	2760 Esplanade, Suite 180	Chico	95973	(530) 965-9090
CA	7833	Scheiper, Robert J.	901 S. La Brea Avenue	Inglewood	90301	(310) 677-1900
CA	7835	Hosseini, Dariush	3902 E. Chapman Avenue	Orange	92869	(714) 538-8881
CA	7836	Scheiper, Robert J.	23565 S. Avalon Boulevard	Carson	90745	(310) 549-1600
CA	7837	Ferdows, Ommid	130 E Grand Avenue, Unit G	El Segundo	90245	(310) 322-6733
CA	7838	Ferdows, Farnad	1844 Pacific Coast Highway	Lomita	90717	(310) 530-2780
CA	7839	Tapia, Fernando	12210 E. Artesia Boulevard	Artesia	90701	(562) 860-3320
CA	7840	Manos, Anthony P.	730 S. Pacific Coast Highway	Redondo Beach	90277	(310) 316-6172
CA	7841	Ferdows, Ommid	201 Pacific Coast Highway	Hermosa Beach	90254	(310) 318-3344
CA	7842	Ferdows, Ommid	3001 Sepulveda Boulevard, Suite A	Manhattan Beach	90266	(310) 546-5833
CA	7843	Manos, Anthony P.	156 W La Habra Boulevard	La Habra	90631	(562) 691-4555
CA	7844	Hosseini, Dariush	1811 W. Commonwealth Avenue, Suite K	Fullerton	92833	(714) 447-4444
CA	7845	Tapia, Fernando	14712 Whittier Boulevard	Whittier	90605	(562) 945-7691
CA	7846	Manos, Anthony P.	122 W. Commonwealth Avenue	Fullerton	92832	(714) 525-5811
CA	7848	Hosseini, Dariush	1235 S. Euclid Street	Anaheim	92802	(714) 776-0111
CA	7849	Miller, Ryan P.	24578 Sunnymead Boulevard, Unit E	Moreno Valley	92553	(951) 924-1931
CA	7850	Mollaghasemi-Tabrizi, Gholamhossein	4012 Chicago Avenue	Riverside	92507	(951) 788-4141
CA	7851	Mollaghasemi-Tabrizi, Gholamhossein	6170 B Van Buren Boulevard	Riverside	92503	(951) 396-2300
CA	7852	Hosseini, Adam	469 Magnolia Avenue, Suite 103	Corona	92879	(951) 737-9000
CA	7853	Manos, Anthony P.	1158 E. 7th Street	Long Beach	90813	(562) 437-4868
CA	7854	Mollaghasemi-Tabrizi, Gholamhossein	11170 Magnolia Avenue, Suite B	Riverside	92505	(951) 785-8888
CA	7855	Hosseini, Dariush	1277 W. Foothill Boulevard	Upland	91786	(909) 981-7555
CA	7856	Ayvazian, Hovig K	857 S. Glendora Avenue	West Covina	91790	(626) 960-3071
CA	7857	Patibandla Rao, Malli	803 W. Whittier Boulevard	Montebello	90640	(323) 262-3030
CA	7859	Hishmeh, Tareq M.	3661 Las Posas	Camarillo	93010	(805) 383-6666
CA	7860	Hishmeh, Tareq M.	475 W. Channel Islands	Port Hueneme	93041	(805) 984-4344
CA	7861	Hishmeh, Tareq M.	1017 N. Ventura Avenue	Ventura	93001	(805) 648-1100
CA	7862	Hishmeh, Tareq M.	1137 S. Oxnard Boulevard	Oxnard	93030	(805) 487-5363
CA	7863	Patibandla Rao, Malli	2464 N. Marks Avenue	Fresno	93722	(559) 691-4300
CA	7864	Schwesinger, Dennis E.	856A North China Lake Boulevard	Ridgecrest	93555	(760) 384-2800
CA	7866	Hosseini, Dariush	17650 Chatsworth Street	Granada Hills	91344	(818) 368-1157
CA	7867	Hishmeh, Tareq M.	5100 Telegraph Road #H	Ventura	93003	(805) 658-0080
CA	7869	Tapia, Fernando	12154 Central Avenue	Chino	91710	(909) 591-7471
CA	7870	Hishmeh, Tareq M.	955 Embarcadero Del Mar	Goleta	93117	(805) 968-8272

Exhibit B Traditional
as of December 31, 2023

CA	7871	Kraniger, Mark J.	1073 N Hacienda Boulevard	La Puente	91744	(626) 369-5080
CA	7873	Hishmeh, Tareq M.	617 N. Millpas Street	Santa Barbara	93103	(805) 966-6131
CA	7874	La Mountain, Doyle	14550 Chase Street #74	Panorama City	91402	(818) 891-7991
CA	7875	Hosseini, Dariush	1650 East 4th Street #A	Ontario	91764	(909) 395-9590
CA	7876	Behm, Timothy	723 S. Central Avenue	Glendale	91204	(818) 246-3850
CA	7877	Schwesinger, Dennis E.	18635 Soledad Canyon Road, Suite 106	Canyon Country	91351	(661) 251-5605
CA	7878	Syriani, Joseph	2315 E. Valley Parkway B	Escondido	92027	(760) 266-7555
CA	7879	Cuesta, Jose I.	8522 Whittier Boulevard	Pico Rivera	90660	(562) 692-9591
CA	7881	Hishmeh, Tareq M.	713 East Main Street	Santa Maria	93454	(805) 925-8656
CA	7882	Hishmeh, Tareq M.	700-C North H Street	Lompoc	93436	(805) 735-7777
CA	7883	Tapia, Fernando	14234 Imperial Highway	La Mirada	90638	(562) 229-3070
CA	7884	Patibandla Rao, Malli	5065 Hollywood Boulevard, Suite 101	Hollywood	90027	(323) 662-6666
CA	7885	Hosseini, Dariush	5166 B Lankershim Boulevard	North Hollywood	91601	(818) 769-3733
CA	7886	Manos, Anthony P.	1510 S. Gaffey	San Pedro	90731	(310) 832-4521
CA	7887	Hosseini, Dariush	16215 Devonshire Street, No. 1	Granada Hills	91344	(818) 363-2020
CA	7888	Manos, Anthony P.	4227 Atlantic Avenue	Long Beach	90807	(562) 492-1323
CA	7889	Patibandla Rao, Malli	4467 Van Nuys Boulevard	Sherman Oaks	91403	(818) 783-3900
CA	7890	Hishmeh, Tareq M.	866 Foothill Boulevard	San Luis Obispo	93405	(805) 544-3636
CA	7891	Hishmeh, Tareq M.	1231 East Grand Avenue, Suite #107	Arroyo Grande	93420	(805) 481-3171
CA	7892	Hishmeh, Tareq M.	3450 Orcutt Road, Building C.1	Santa Maria	93455	(805) 937-7233
CA	7893	Hosseini, Dariush	14152 Newport Avenue	Tustin	92780	(714) 832-4900
CA	7894	Patibandla Rao, Malli	15908 Halliburton Road	Hacienda Heights	91745	(626) 369-0999
CA	7895	Manos, Anthony P.	15900 - A Crenshaw Boulevard	Gardena	90249	(310) 327-7266
CA	7896	Gawe, Joey	1000 C Street, Suite 40	Galt	95632	(209) 730-1233
CA	7897	Hosseini, Dariush	12501 Burbank Boulevard	Valley Village	91607	(747) 248-1100
CA	7900	La Mountain, Doyle	107 E. Colton Avenue	Redlands	92374	(909) 798-2997
CA	7901	Iqbal, Ali Hassan	3264 Adeline Street	Berkeley	94703	(510) 420-1155
CA	7902	Omi, Alexander Roberts	1421 Solano Avenue	Albany	94706	(510) 526-9346
CA	7903	Brumleve, Dan T.	2521 N Main Street	Walnut Creek	94596	(925) 944-5400
CA	7906	Patibandla Rao, Malli	6306 Fair Oaks Boulevard	Carmichael	95608	(916) 489-4800
CA	7912	Rea, Samuel L.	422 N. Imperial Avenue	El Centro	92243	(760) 353-8100
CA	7913	Hishmeh, Tareq M.	205 Port Chicago Highway	Bay Point	94565	(925) 592-4040
CA	7914	Hishmeh, Tareq M.	1460 East Cotati Avenue #D	Rohnert Park	94928	(707) 795-8227
CA	7915	Ferdows, Farnad	97 Woodland Avenue	San Rafael	94901	(415) 456-9950
CA	7916	Ferdows, Farnad	15750 Monterey Highway	Morgan Hill	95037	(669) 270-1400
CA	7917	Ferdows, Farnad	728 S State Street	Ukiah	95482	(707) 621-5700
CA	7918	Singh, Rajbir	3170 Santa Rita Road #A1	Pleasanton	94566	(925) 846-8888

Exhibit B Traditional
as of December 31, 2023

CA	7919	Iqbal, Ali Hassan				1301C Palmetto Avenue	Pacifica	94044	(650) 355-7300
CA	7920	Brumleve, Dan T.				1215 Lincoln Avenue	Alameda	94501	(510) 865-8000
CA	7921	Hishmeh, Tareq M.				35248 Newark Boulevard	Newark	94560	(510) 796-4440
CA	7923	Turner, D. Craig				2605 Pacific Avenue	Stockton	95204	(209) 798-0330
CA	7924	Turner, D. Craig				1045 North Wilson Way	Stockton	95205	(209) 299-7272
CA	7925	Iqbal, Ali Hassan				100 5th Avenue	Redwood City	94063	(650) 298-8911
CA	7926	DeGrandis, Greg				16605 South Harlan Road	Lathrop	95330	(209) 299-3131
CA	7927	Salmons, Shawn				169 E. 4th Avenue	San Mateo	94401	(650) 344-3030
CA	7929	Ferdows, Farnad				2566 Old First Street	Livermore	94550	(925) 443-4333
CA	7930	Iqbal, Ali Hassan				240-B Cambridge Avenue	Palo Alto	94306	(650) 326-6552
CA	7931	Ferdows, Farnad				1711 West El Camino Real	Mountain View	94040	(650) 964-4001
CA	7932	Ferdows, Farnad				3207 Cabrillo Avenue	Santa Clara	95051	(408) 241-2828
CA	7933	Iqbal, Ali Hassan				930 W. Hamilton Avenue, Suite 100	Campbell	95008	(669) 289-1100
CA	7934	Hishmeh, Tareq M.				29619 Mission Boulevard	Hayward	94544	(510) 886-3030
CA	7935	Iqbal, Ali Hassan				2408 C Junipero Serra Boulevard	Daly City	94015	(650) 994-9440
CA	7936	Tapia, Fernando				10986 Sierra Avenue #300	Fontana	92337	(909) 550-1800
CA	7937	Iqbal, Ali Hassan				1158 Mission Road	South San Francisco	94080	(650) 875-9440
CA	7938	Iqbal, Ali Hassan				6059 Calahan Avenue, Suite 90	San Jose	95123	(669) 255-4111
CA	7939	Hishmeh, Tareq M.				40756 Grimmer Boulevard	Fremont	94538	(510) 440-8200
CA	7940	DeGrandis, Greg				1205 S. Main Street	Manteca	95337	(209) 624-1010
CA	7941	DeGrandis, Greg				1571 Geer Rd	Turlock	95380	(209) 669-3131
CA	7942	Ferdows, Farnad				1105 W. Main Street	Merced	95340	(209) 233-9182
CA	7944	Ferdows, Farnad				3040 Park Avenue, Suite E1	Merced	95348	(209) 722-8022
CA	7945	DeGrandis, Greg				510 East Bellevue Road	Atwater	95301	(209) 357-9866
CA	7946	DeGrandis, Greg				800 Commerce Avenue	Atwater	95301	(219) 812-0088
CA	7947	Turner, D. Craig				9321 Thornton Road, Suite A	Stockton	95209	(209) 951-3030
CA	7948	DeGrandis, Greg				2119 Patterson Road, Suite 5	Riverbank	95367	(209) 719-4999
CA	7950	DeGrandis, Greg				460 Winton Parkway	Livingston	95334	(209) 635-6300
CA	7951	DeGrandis, Greg				1505 W. F Street	Oakdale	95361	(209) 783-1177
CA	7954	Shehadeh, Issa J.				1700 West Imola Avenue, Unit A	Napa	94559	(707) 252-3030
CA	7956	Turner, D. Craig				1989 Peabody Road, Suite 6	Vacaville	95687	(707) 447-4004
CA	7957	Manos, Anthony P.				10207 S. Central Avenue	Los Angeles	90002	(923) 886-3800
CA	7961	Patibandla Rao, Malli				2654 Marconi Avenue, Suite 115	Sacramento	95821	(916) 971-3033
CA	7963	DeGrandis, Greg				2001-G West Cleveland Avenue	Madera	93637	(559) 675-5000
CA	7966	Hosseini, Dariush				9874 De Soto Avenue	Chatsworth	91311	(818) 882-2200
CA	7972	Ferdows, Farnad				987 Edgewood Circle, Unit A, B & C	S. Lake Tahoe	96150	(530) 543-1235
CA	7973	Hishmeh, Tareq M.				2931 Harbor Street, Suite K	Pittsburg	94565	(925) 427-3030

Exhibit B Traditional
as of December 31, 2023

CA	7974	DeGrandis, Greg	1211 W. Monte Vista	Turlock	95382	(209) 850-8282
CA	7978	Singh, Rajbir	33600 Alvarado Niles Road	Union City	94587	(510) 487-8787
CA	7980	Ferdows, Farnad	324 Walnut, Space B	Chico	95928	(530) 891-5888
CA	7981	Ferdows, Farnad	1759 Lewis Road, Bldg. 660	Monterey	93944	(831) 583-8585
CA	7982	Ferdows, Farnad	2245 The Alameda	Santa Clara	95050	(669) 242-5344
CA	7984	Iqbal, Ali Hassan	907 Del Mar Avenue	San Jose	95128	(408) 287-3755
CA	7985	Ferdows, Farnad	3853 Seven Trees Boulevard	San Jose	95111	(408) 578-3030
CA	7990	Ferdows, Farnad	1022 Broadway Avenue #B	Seaside	93955	(831) 899-4557
CA	7991	Ferdows, Farnad	265 Reservation Road, Suite Q	Marina	93933	(831) 883-4040
CA	7992	Ferdows, Farnad	2391 Mission Street	Santa Cruz	95060	(831) 429-9955
CA	7993	Ferdows, Farnad	1255 First Street	Gilroy	95020	(408) 842-6970
CA	7994	Iqbal, Ali Hassan	576 E. Santa Clara Street, Suite 20	San Jose	95112	(408) 298-3030
CA	7995	Iqbal, Ali Hassan	1909 Tully Road	San Jose	95122	(408) 923-3030
CA	7996	Patibandla Rao, Malli	1331 Broadway	Placerville	95667	(530) 303-6777
CA	8000	Patibandla Rao, Malli	7220 W. Sunset Boulevard	Los Angeles	90046	(323) 380-7711
CA	8100	Hosseini, Dariush	13302 Century Boulevard	Garden Grove	92843	(714) 534-7444
CA	8102	Ferdows, Farnad	247 Shoreline Highway	Mill Valley	94941	(415) 381-1900
CA	8103	Singh, Rajbir	500 Bollinger Canyon Way, Unit A2	San Ramon	94582	(925) 735-0114
CA	8106	Rahim, Abdul Hadi	22962 Clawiter Road, Unit 2	Hayward	94545	(510) 783-9950
CA	8108	Singh, Rajbir	22525 Main Street	Hayward	94541	(510) 537-3700
CA	8109	Hamill, R. Brent	3538 Tweedy Boulevard	South Gate	90280	(323) 563-3030
CA	8110	Kraniger, Mark J.	4561 Peck Road	El Monte	91732	(626) 448-3030
CA	8111	Patibandla Rao, Malli	703 S. Atlantic Boulevard	Alhambra	91801	(626) 289-5694
CA	8112	Hamill, R. Brent	7021 Atlantic Avenue	Bell	90201	(323) 560-6660
CA	8113	Ferdows, Ommid	12237 Santa Monica Boulevard	Los Angeles	90025	(310) 826-3030
CA	8115	Hosseini, Dariush	1007 Avenue East J.	Lancaster	93535	(661) 945-9456
CA	8116	Hosseini, Dariush	42056 50th Street W	Lancaster	93536	(661) 943-2456
CA	8118	Khazan, Houman	393 Redondo Avenue	Long Beach	90814	(562) 434-9971
CA	8119	Manos, Anthony P.	1640 B W. Carson Street	Torrance	90501	(310) 533-1174
CA	8120	Syriani, Joseph	4160 E. Florida Avenue	Hemet	92544	(951) 927-1101
CA	8121	Tapia, Fernando	74580 Highway 111 #C-3	Palm Desert	92260	(760) 340-5002
CA	8122	Patibandla Rao, Malli	8126 Sunland Boulevard	Sun Valley	91352	(818) 768-8833
CA	8123	Hishmeh, Tareq M.	9410 Telephone Road, Suite A & B	Ventura	93003	(805) 658-9911
CA	8125	Tapia, Fernando	11849 Whittier Boulevard	Whittier	90601	(562) 695-2600
CA	8126	Patibandla Rao, Malli	1937 Tyler Avenue	South El Monte	91733	(626) 579-3030
CA	8127	Patibandla Rao, Malli	1935 E. Colorado Boulevard	Pasadena	91107	(626) 584-0866
CA	8128	Kraniger, Mark J.	14604 Ramona Boulevard #3	Baldwin Park	91706	(626) 960-5002

Exhibit B Traditional
as of December 31, 2023

CA	8129	Hamill, R. Brent	954 W. Manchester Avenue	Los Angeles	90044	(323) 758-5500
CA	8130	Behm, Nikita Spiroff	1411 Huntington Drive, Suite 10	Duarte	91010	(626) 359-3030
CA	8131	Patibandla Rao, Malli	6051 Hollywood Boulevard, Suite 106	Hollywood	90028	(323) 463-7044
CA	8132	La Mountain, Doyle	6805 Sepulveda Boulevard	Van Nuys	91405	(818) 909-0088
CA	8133	Tapia, Fernando	7433 Florence Avenue	Downey	90240	(562) 806-4631
CA	8134	Iqbal, Ali Hassan	320 Bayshore Boulevard	San Francisco	94124	(415) 647-8400
CA	8135	Singh, Rajbir	16308 E 14th Street	San Leandro	94578	(510) 481-0333
CA	8137	Hishmeh, Tareq M.	1581 Sycamore Avenue	Hercules	94547	(510) 222-9100
CA	8138	Behm, Timothy	1244 W. Glencaks Boulevard	Glendale	91201	(818) 247-3340
CA	8140	Brumleve, Dan T.	4041 Alhambra Avenue	Martinez	94553	(925) 372-5555
CA	8141	Patibandla Rao, Malli	633 S. Arroyo Parkway	Pasadena	91105	(626) 584-1976
CA	8142	Khazan, Houman	16486 Bolsa Chica Street	Huntington Beach	92649	(714) 840-9200
CA	8144	Manos, Anthony P.	24404 Hawthorne Boulevard	Torrance	90505	(310) 373-3372
CA	8145	Ferdows, Farnad	355 Oro Dam Boulevard	Oroville	95965	(530) 403-5333
CA	8146	Mollaghasemi-Tabrizi, Gholamhossein	2501 White Lane, Suite B	Bakersfield	93304	(661) 831-1000
CA	8147	Hishmeh, Tareq M.	2084 9th Street #A	Los Osos	93402	(805) 528-0800
CA	8148	Tapia, Fernando	72-440 Ramon Road, Suite B1	Thousand Palms	92276	(760) 343-0817
CA	8150	Rodriguez, Abraham	1204 Fruitvale Avenue	Oakland	94601	(510) 536-3200
CA	8151	Manos, Anthony P.	2143 N. Tustin Street, Suite 8	Orange	92865	(714) 974-3000
CA	8152	Ayvazian, Hovig K	706 E. Foothill Boulevard	San Dimas	91773	(909) 592-2806
CA	8153	Behm, Timothy	433 N. Glencaks Boulevard	Burbank	91201	(818) 841-3337
CA	8156	Hosseini, Dariush	366 W. Foothill Boulevard	Claremont	91711	(909) 624-1960
CA	8157	Scheiper, Robert J.	2101 W. Century Boulevard	Los Angeles	90047	(323) 756-0080
CA	8160	Shariff, Sammy M.	2333-B Buchanan Road	Antioch	94509	(925) 757-3030
CA	8161	Hishmeh, Tareq M.	25 West D Street, Suite C	Lemoore	93245	(559) 924-3581
CA	8164	Patibandla Rao, Malli	2057 N. Los Robles Avenue	Pasadena	91104	(626) 791-9285
CA	8166	Tapia, Fernando	425 S. Sunrise Way H #9	Palm Springs	92262	(760) 320-4041
CA	8167	Ferdows, Farnad	708 W. 11th Street	Tracy	95376	(209) 836-3636
CA	8168	Ferdows, Farnad	10652 Riverside Drive	North Hollywood	91602	(818) 769-2800
CA	8170	Tapia, Fernando	1913 N. Placentia Avenue	Placentia	92870	(714) 993-9300
CA	8173	Patibandla Rao, Malli	5524 York Boulevard	Los Angeles	90042	(323) 255-5999
CA	8174	Ayvazian, Hovig K	826 N Glendora Avenue	Covina	91724	(626) 331-9911
CA	8175	Shahrviri, Kiana	30867 E. Thousand Oaks Boulevard	Westlake Village	91362	(818) 735-5400
CA	8176	Behm, Timothy	2015 Hollywood Way	Burbank	91505	(818) 954-9600
CA	8177	Patibandla Rao, Malli	6780 North Blackstone Avenue	Fresno	93710	(559) 431-3001
CA	8180	Manos, Anthony P.	9170 W. Olympic Boulevard	Beverly Hills	90212	(310) 273-8600
CA	8185	Manos, Anthony P.	3560 W. Temple Avenue, Suite G	Pomona	91768	(909) 417-3300

Exhibit B Traditional
as of December 31, 2023

CA	8187	Hishmeh, Tareq M.			2011 W. Tulare	Visalia	93277	(559) 627-8888
CA	8188	Lee, Lin J.			1561 Farmers Lane	Santa Rosa	95405	(707) 578-6161
CA	8189	DeGrandis, Greg			14061 W. Whitesbridge Avenue	Kerman	93630	(559) 552-7700
CA	8192	Kraniger, Mark J.			1725 S. Nogales	Rowland Heights	91748	(626) 912-1130
CA	8193	Patibandla Rao, Malli			4815 Valley Boulevard, Suite H	Los Angeles	90032	(323) 222-7722
CA	8194	Ferdows, Farnad			992 W. El Camino Real	Sunnyvale	94087	(408) 736-3666
CA	8200	Syriani, Joseph			31165 Highway 79 South G-1	Temecula	92591	(951) 676-0707
CA	8201	Cuesta, Jose I.			7985 Westminster Boulevard	Westminster	92683	(714) 897-2280
CA	8205	Manos, Anthony P.			2251 W. Rosecrans Avenue, Suite #4	Compton	90059	(323) 756-3030
CA	8206	Hishmeh, Tareq M.			8305 El Camino Real	Atascadero	93422	(805) 466-7880
CA	8207	Manos, Anthony P.			1285 S. Garey Avenue	Pomona	91766	(909) 622-0229
CA	8209	Hishmeh, Tareq M.			530 Kern Street, Suite A	Taft	93268	(661) 763-3030
CA	8210	Ferdows, Ommid			865 Silver Spur Road	Rolling Hills Estates	90274	(310) 544-1445
CA	8212	Hosseini, Dariush			17020 Ventura Boulevard	Encino	91316	(818) 981-5811
CA	8214	Hosseini, Dariush			1544 W. Redondo Beach Boulevard	Gardena	90247	(310) 327-0444
CA	8215	Tapia, Fernando			2550 S. Vineyard Avenue #B	Ontario	91761	(909) 673-0383
CA	8217	Iqbal, Ali Hassan			2665 Geneva Avenue	Daly City	94014	(415) 988-7407
CA	8219	La Mountain, Doyle			4275 University Parkway, Suite 104	San Bernardino	92407	(909) 880-1831
CA	8223	Patibandla Rao, Malli			1400 E. Washington Boulevard	Pasadena	91104	(626) 794-3030
CA	8224	Hosseini, Dariush			8320 Lincoln Boulevard, Suite 106	Los Angeles	90045	(310) 216-6886
CA	8225	Hishmeh, Tareq M.			11420 N. Ventura Avenue, Suite 112-112	Ojai	93023	(805) 640-0080
CA	8226	Manos, Anthony P.			4285 El Segundo Boulevard	Hawthorne	90250	(310) 219-0008
CA	8227	Hamill, R. Brent			2324 Whittier Boulevard, Suite #4	Los Angeles	90023	(323) 268-2000
CA	8229	Hishmeh, Tareq M.			449 Stony Point Road	Santa Rosa	95401	(707) 545-8111
CA	8230	Tapia, Fernando			7840 Imperial Highway	Downey	90242	(562) 861-3030
CA	8232	Hishmeh, Tareq M.			185 S. Patterson Avenue, Suite G	Goleta	93111	(805) 683-1155
CA	8233	Tapia, Fernando			16967 Main Street, Suite 105 & 106	Hesperia	92345	(760) 244-3730
CA	8235	Schwesinger, Dennis E.			27737 Bouquet Canyon Road, Suite 134	Santa Clarita	91350	(661) 296-2080
CA	8236	Hoffman, Stacy A.			174 West Main Street	Brawley	92227	(760) 344-1860
CA	8237	Hishmeh, Tareq M.			13061 Rosedale Highway, Suite E	Bakersfield	93314	(661) 401-6100
CA	8238	Manos, Anthony P.			103 W. Central Boulevard, Suite A	Brea	92821	(714) 529-7575
CA	8240	Iqbal, Ali Hassan			5313 Prospect	San Jose	95129	(408) 253-3030
CA	8241	Rodriguez, Abraham			3639 MacArthur Boulevard	Oakland	94619	(510) 530-6601
CA	8242	Patibandla Rao, Malli			13044 Glenoaks Boulevard	Sylmar	91342	(818) 367-3033
CA	8243	Hosseini, Dariush			13931 Van Nuys Boulevard	Arleta	91331	(818) 897-0355
CA	8244	Patibandla Rao, Malli			7125 Beverly Boulevard	Los Angeles	90036	(323) 936-1140
CA	8245	Tobie, Pamela A.			6947 Linda Vista Road, Suite D&F	San Diego	92110	(619) 296-2220

Exhibit B Traditional
as of December 31, 2023

CA	8246	Mollaghasemi-Tabrizi, Gholamhossein	6401 White Lane #111	Bakersfield	93309	(661) 397-3030
CA	8248	Varner, Russell L.	2560 N. Perris Boulevard, Suite #G5	Perris	92571	(951) 943-4443
CA	8249	DeGrandis, Greg	100 Robertson Boulevard	Chowchilla	93610	(559) 775-6060
CA	8251	La Mountain, Doyle	25715 Redlands Boulevard	Redlands	92373	(909) 796-1100
CA	8252	Behm, Nikita Spiroff	734 N. Azusa Avenue	Azusa	91702	(626) 969-3030
CA	8253	Mollaghasemi-Tabrizi, Gholamhossein	16090 Perris Boulevard, Suite 1A	Moreno Valley	92551	(951) 419-3400
CA	8255	Tapia, Fernando	560 E. Virginia Way, Unit B	Barstow	92311	(760) 256-0668
CA	8258	Hishmeh, Tareq M.	3006 State Street	Santa Barbara	93105	(805) 898-0606
CA	8261	Syriani, Joseph	16738-K Lakeshore Drive	Lake Elsinore	92330	(951) 245-2882
CA	8264	Hishmeh, Tareq M.	2138 Spring Street	Paso Robles	93446	(805) 239-8505
CA	8266	Tapia, Fernando	13900 Palm Drive, Suite E	Desert Hot Springs	92240	(760) 251-1444
CA	8269	Hosseini, Dariush	10431 Lemon Street #N	Alta Loma	91737	(909) 989-7777
CA	8270	Hosseini, Dariush	8662 Lindley Avenue	Northridge	91325	(818) 349-0995
CA	8271	Tapia, Fernando	81942 US Highway 111	Indio	92201	(760) 342-0028
CA	8273	Hosseini, Dariush	8313 Laurel Canyon Boulevard	Sun Valley	91352	(818) 768-7888
CA	8274	Kraniger, Mark J.	18770 Amar Road	Walnut	91789	(626) 913-4044
CA	8276	Rodriguez, Abraham	3360 Grand Avenue	Oakland	94610	(510) 839-1952
CA	8278	Ferdows, Farnad	154 Country Club Gate Center	Pacific Grove	93950	(831) 372-1999
CA	8279	Iqbal, Ali Hassan	2232 Alum Rock Avenue, Suite #10	San Jose	95116	(669) 202-4040
CA	8280	Manos, Anthony P.	15114 Inglewood Avenue	Lawndale	90260	(310) 676-0017
CA	8282	Hamill, R. Brent	3631 Crenshaw Boulevard, Suite 113	Los Angeles	90016	(323) 737-7700
CA	8283	Manos, Anthony P.	548 S State College Boulevard	Anaheim	92806	(714) 774-4494
CA	8284	Manos, Anthony P.	501 W. Willow Street	Long Beach	90806	(562) 427-6612
CA	8286	La Mountain, Doyle	795 W. Highland	San Bernardino	92405	(909) 881-3500
CA	8287	Schwesinger, Dennis E.	25450 The Old Road	Stevenson Ranch	91381	(661) 401-6100
CA	8288	Hosseini, Dariush	12911 Chapman Avenue	Garden Grove	92840	(714) 750-2224
CA	8289	Patibandla Rao, Malli	3502 W. Sunset Boulevard	Los Angeles	90026	(323) 667-2323
CA	8290	Iqbal, Ali Hassan	1710 Berryessa Road #102	San Jose	95133	(408) 259-9090
CA	8292	La Mountain, Doyle	3654 E. Highland Avenue #1	Highland	92346	(909) 863-1200
CA	8293	Syriani, Joseph	31546 Railroad Canyon Road	Canyon Lake	92587	(951) 244-5111
CA	8294	Schwesinger, Dennis E.	26471 Carl Boyer Drive	Santa Clarita	91350	(661) 401-6464
CA	8300	Hosseini, Dariush	603 Sycamore Avenue	Vista	92083	(760) 727-6300
CA	8301	Ferdows, Ommid	633-C.E. University	Carson	90746	(310) 516-9800
CA	8302	Hishmeh, Tareq M.	512 Main Street	Watsonville	95076	(831) 728-4444
CA	8303	Hamill, R. Brent	821 S. Long Beach Boulevard	Compton	90221	(310) 635-1212
CA	8304	O'Connell, Timothy	1301-1307 West 7th Street	Los Angeles	90017	(682) 200-6636
CA	8305	O'Connell, Timothy	270 S. Rampart Boulevard	Los Angeles	90057	(213) 383-1330

Exhibit B Traditional
as of December 31, 2023

CA	8306	Manos, Anthony P.	2815 S. Robertson Boulevard	Los Angeles	90034	(310) 559-3030
CA	8307	Hishmeh, Tareq M.	2581 E. Vineyard Avenue, Suite M	Oxnard	93036	(805) 988-1544
CA	8308	La Mountain, Doyle	22488 Barton Road	Grand Terrace	92313	(909) 783-3030
CA	8309	Kraniger, Mark J.	23082 Ridge Route Drive, Suite B	Lake Forest	92630	(949) 770-2112
CA	8310	Ferdows, Ommid	1865 Lincoln Boulevard	Santa Monica	90404	(310) 396-9696
CA	8313	Kraniger, Mark J.	5742 E. Olympic Boulevard	Commerce	90022	(323) 888-1555
CA	8314	Hosseini, Dariush	2015 Garnet Avenue	San Diego	92109	(658) 274-3030
CA	8315	Behm, Nikita Spiroff	3430 Ocean View Boulevard #H	Glendale	91208	(818) 249-5530
CA	8316	Tapia, Fernando	58146 Highway 62	Yucca Valley	92284	(760) 365-7730
CA	8318	Patibandla Rao, Malli	4543 E. Kings Canyon Road	Fresno	93702	(559) 251-7000
CA	8321	Mollaghasemi-Tabrizi, Gholamhossein	24853 Alessandro Boulevard, Suite 5	Moreno Valley	92553	(951) 924-5997
CA	8322	Ayvazian, Hovig K	41234 Big Bear Boulevard	Big Bear Lake	92315	(909) 866-3555
CA	8326	Mollaghasemi-Tabrizi, Gholamhossein	6410 Magnolia Avenue	Riverside	92506	(951) 787-9999
CA	8327	Syriani, Joseph	33982 Mission Trail, Suite C	Wildomar	92595	(951) 674-7766
CA	8330	Hishmeh, Tareq M.	393 W. Los Angeles Avenue (aka 393 Los Angeles Avenue)	Moorpark	93021	(805) 523-3030
CA	8332	Syriani, Joseph	2435 W. Florida Avenue	Hemet	92545	(951) 658-0026
CA	8333	Hishmeh, Tareq M.	1655 Mission Drive	Solvang	93463	(805) 686-1177
CA	8335	Turner, D. Craig	7908 West Lane #219A	Stockton	95210	(209) 956-3030
CA	8337	Hosseini, Dariush	22643 Ventura Boulevard	Woodland Hills	91364	(818) 224-3300
CA	8338	Turner, D. Craig	402 E. Charter Way	Stockton	95206	(209) 464-0303
CA	8339	Hosseini, Dariush	4604 East Avenue S	Palmdale	93552	(661) 285-7400
CA	8340	Lam, Danh Cong	24681 La Plaza, Unit 130	Dana Point	92629	(949) 496-4646
CA	8341	Manos, Anthony P.	4746 E. Cesar Chavez Avenue	East Los Angeles	90022	(323) 268-3030
CA	8342	Patibandla Rao, Malli	12040 Foothill Boulevard, Unit 101 A&B	Lakeview Terrace	91342	(818) 686-0303
CA	8344	Hishmeh, Tareq M.	470 W Pleasant Valley Road	Oxnard	93033	(805) 488-8101
CA	8345	Patibandla Rao, Malli	63 W. Shaw, Suite 101	Clovis	93612	(559) 298-9111
CA	8347	Saaliabi, Mahmood	5401 S. Figueroa Street	Los Angeles	90037	(323) 753-6888
CA	8349	Tapia, Fernando	3668 Adobe Road	Twentynine Palms	92277	(760) 367-2273
CA	8350	Oliva, David Moises	1337-1339 Rocking W Drive, Suites B & C	Bishop	93514	(760) 615-0055
CA	8351	Manos, Anthony P.	5595 E. Santa Ana Canyon Road	Anaheim	92807	(714) 637-6111
CA	8352	Manos, Anthony P.	21028 Hawthorne Boulevard	Torrance	90503	(310) 316-8199
CA	8354	Hosseini, Dariush	1315 W. Warner Avenue	Santa Ana	92704	(714) 979-3030
CA	8355	Patibandla Rao, Malli	9443 Las Tunas Street, Suite C	Temple City	91780	(626) 285-0033
CA	8357	Casey, Shane B.	520407 Basiline Road	Camp Pendleton	92055	(760) 575-9880
CA	8358	Patibandla Rao, Malli	1381-B West Sunset Boulevard	Los Angeles	90026	(213) 413-8444
CA	8359	Tapia, Fernando	20226 CA-18 W, Unit A	Apple Valley	92307	(760) 946-2323
CA	8360	Hosseini, Dariush	1015 S. Main Street, Suite B	Santa Ana	92701	(714) 565-7900

Exhibit B Traditional
as of December 31, 2023

CA	8362	Tapia, Fernando	51616 Harrison Street	Coachella	92236	(760) 398-3030
CA	8364	Tapia, Fernando	16135 Sierra Lakes Parkway, Suite 250	Fontana	92336	(909) 371-5100
CA	8367	Khazan, Houman	2934 Westminster Avenue	Seal Beach	90740	(562) 493-2212
CA	8368	Tapia, Fernando	12274 Palmdale Road, Unit A6	Victorville	92392	(760) 381-8709
CA	8370	Hamill, R. Brent	3309 West Pico Boulevard	Los Angeles	90019	(323) 735-8008
CA	8372	Hishmeh, Tareq M.	2360 Main Street #B	Morro Bay	93442	(805) 772-6151
CA	8375	Hosseini, Dariush	1075 S. Mission Road, Suite B	Fallbrook	92028	(760) 728-1223
CA	8376	Saaliabi, Mahmood	1740 S. Hoover	Los Angeles	90006	(213) 748-7774
CA	8380	Hosseini, Dariush	6986 El Camino Real, Suite A	Carlsbad	92009	(760) 438-3033
CA	8382	Hishmeh, Tareq M.	3555 Clares Street, Suite A	Capitola	95010	(831) 475-1212
CA	8384	Oliva, David Moises	1934 Meridian Boulevard, Suite A	Mammoth Lakes	93546	(760) 934-5555
CA	8385	Hamill, R. Brent	740 S. Olive Street	Los Angeles	90014	(213) 623-2424
CA	8386	Patibandla Rao, Malli	2220 N. Moorpark #104	Thousand Oaks	91360	(805) 496-6221
CA	8388	Iqbal, Ali Hassan	3300 East Castro Valley Boulevard, Suite G	Castro Valley	94552	(510) 581-3033
CA	8389	Kraniger, Mark J.	30242 Crown Valley Parkway, Suite #B-1B	Laguna Niguel	92677	(949) 249-1522
CA	8390	Gagliardi, Cindy L.	4973 Yorba Ranch Road #C	Yorba Linda	92887	(714) 777-6700
CA	8391	Manos, Anthony P.	5151 W. Pico Boulevard, Unit B	Los Angeles	90019	(323) 934-3030
CA	8392	Ferdows, Farnad	615 Caliente Drive	Sunnyvale	94085	(408) 732-3030
CA	8402	Patibandla Rao, Malli	7213 Foothill Boulevard	Tujunga	91042	(818) 352-0030
CA	8403	Hosseini, Dariush	14130 Culver Drive, Suite G	Irvine	92604	(949) 559-1515
CA	8405	Behm, Timothy	26500 Agoura Road	Calabasas	91302	(818) 880-0550
CA	8406	Patibandla Rao, Malli	829 S Atlantic Boulevard	Monterey Park	91754	(626) 576-2000
CA	8407	Hosseini, Dariush	3211 Holiday Court, Suite 103-105	La Jolla	92037	(858) 452-8273
CA	8409	Tapia, Fernando	78-134 Calle Tampico, Suite 100	La Quinta	92253	(760) 564-8525
CA	8414	Tapia, Fernando	18790 Valley Boulevard, Unit B	Bloomington	92316	(909) 820-3000
CA	8416	Shehadeh, Issa J.	5999 Lindhurst Avenue	Marysville	95901	(530) 741-3030
CA	8418	Iqbal, Ali Hassan	3116 Noriega Street	San Francisco	94122	(415) 681-8100
CA	8419	Tapia, Fernando	4955 Felspar Street, Space E	Riverside	92509	(951) 360-3330
CA	8421	Iqbal, Ali Hassan	5200 Geary Boulevard, Suite D	San Francisco	94118	(415) 387-3030
CA	8422	Miller, Ryan P.	4200 Chino Hills Parkway, Suite 345	Chino Hills	91709	(909) 393-8256
CA	8423	Hosseini, Dariush	9889 Carmel Mountain Road	San Diego	92129	(858) 484-3030
CA	8424	Patibandla Rao, Malli	15245 Roscoe Boulevard	Panorama City	91402	(818) 893-7777
CA	8431	Taylor, Joney E.	1440 Beaumont Avenue, Suite A1	Beaumont	92223	(951) 769-5777
CA	8432	Manos, Anthony P.	2025 E. Florence Avenue	Los Angeles	90001	(323) 587-0300
CA	8433	Syriani, Joseph	26920 Cherry Hills Boulevard	Sun City	92586	(951) 672-1545
CA	8434	Ferdows, Farnad	11921 Beach Boulevard	Stanton	90680	(714) 891-8235
CA	8435	Hishmeh, Tareq M.	1121 Valley Boulevard, Suite E	Tehachapi	93561	(661) 822-3444

Exhibit B Traditional
as of December 31, 2023

CA	8442	Tapia, Fernando	15263 Hook Boulevard, Suite #E	Victorville	92394	(760) 951-1782
CA	8443	Ferdows, Farnad	725 West Hobsonway	Blythe	92225	(760) 921-3030
CA	8447	Schwesinger, Dennis E.	23329 Lyons Avenue #C	Valencia	91355	(661) 254-0300
CA	8448	Tapia, Fernando	8127 Mulberry Avenue, Suite #101	Fontana	92335	(909) 356-4114
CA	8449	Gagliardi, Cindy L.	27230 Lapaz, Suite M	Mission Viejo	92692	(949) 472-5050
CA	8452	Scheiper, Robert J.	955 N. Labrea Avenue	Inglewood	90302	(310) 673-9090
CA	8458	Patibandla Rao, Malli	2933 Division Street	Los Angeles	90065	(323) 225-1080
CA	8459	Gagliardi, Cindy L.	32211 Camino Capistrano, E-102	San Juan Capistrano	92675	(949) 493-3030
CA	8461	Brumleve, Dan T.	3544 Clayton Road	Concord	94519	(925) 827-3030
CA	8465	Schwesinger, Dennis E.	31744 Castaic Road, Suite 102	Castaic	91384	(661) 294-0200
CA	8468	Syriani, Joseph	26684 Margarita Road #105/106	Murrieta	92563	(951) 698-5581
CA	8475	Ferdows, Farnad	1036 E. Broadway Street	Needles	92363	(760) 326-3030
CA	8480	DeGrandis, Greg	2737 B Whitson Avenue	Selma	93662	(559) 379-7999
CA	8485	Tapia, Fernando	31855 #7 Date Palm Drive	Cathedral City	92234	(760) 778-5555
CA	8486	Brumleve, Dan T.	4530 Main Street	Oakley	94561	(925) 625-5555
CA	8488	Hishmeh, Tareq M.	129 S. Frontage Road	Nipoma	93444	(805) 929-5050
CA	8489	Patibandla Rao, Malli	1129 C Street	Fresno	93706	(559) 486-7000
CA	8491	Behm, Timothy	1120 E. Broadway	Glendale	91205	(818) 247-9500
CA	8493	Gagliardi, Cindy L.	1100 S. Coast Highway, Suite 205	Laguna Beach	92651	(949) 376-0333
CA	8500	Schubert, Craig	916 E. Cypress Avenue, Suite 100	Redding	96002	(530) 244-3030
CA	8503	Hosseini, Dariush	943-C Olay Lakes Road	Chula Vista	91913	(619) 656-3232
CA	8504	Ferdows, Farnad	1620 Crows Landing Road, Suite J	Modesto	95359	(209) 809-4300
CA	8505	Hosseini, Dariush	3485 Del Mar Heights Road, Suite A5	San Diego	92130	(658) 794-2929
CA	8506	Casey, Shane B.	13030 Vandegriff Boulevard	Camp Pendelton	95055	(760) 575-9850
CA	8508	Meussner, Harry J.	2272 Michelson Drive	Irvine	92612	(949) 222-0333
CA	8509	Hosseini, Dariush	1510 Baker Street	Costa Mesa	92626	(714) 435-7900
CA	8510	Gobrial, Nehad E.	29200 Portola Parkway	Lake Forest	92630	(949) 855-2223
CA	8511	Mollaghasemi-Tabrizi, Gholamhossein	19510 Van Buren Boulevard, Suite F-8	Riverside	92508	(951) 656-2222
CA	8512	Belfatti, Richard D. III	1659 Branham Lane, Suite G	San Jose	95118	(408) 448-3722
CA	8513	Gobrial, Nehad E.	31961 Dove Canyon Drive, Suite A	Trabuco Canyon	92679	(949) 888-8555
CA	8514	Ferdows, Farnad	31240 Palos Verdes Drive West	Rancho Palos Verdes	90275	(310) 265-4999
CA	8516	Ferdows, Farnad	38487 N. Fremont Boulevard	Fremont	95436	(510) 494-8094
CA	8517	Singh, Rajbir	7214 Regional Street	Dublin	94568	(925) 261-3131
CA	8518	Pineda, Maribel	3536 E. Pacific Coast Highway, #B	Corona Del Mar	92625	(949) 673-3653
CA	8519	Patibandla Rao, Malli	7218 Auburn Boulevard	Citrus Heights	95610	(916) 726-3030
CA	8520	Patibandla Rao, Malli	8118 Gerber Road	Sacramento	95828	(916) 627-1214
CA	8521	Ferdows, Farnad	500 5th Street	Eureka	95501	(707) 442-3030

Exhibit B Traditional
as of December 31, 2023

CA	8522	Tapia, Fernando	1751 N. Sunrise Way B2	Palm Springs	92262	(760) 904-3434
CA	8523	Oberg, Jared James	751 Sterling Parkway, Suite 300	Lincoln	95648	(916) 884-0777
CA	8524	Syriani, Joseph	24088 Clinton Keith Road, Suite 105	Wildomar	92595	(951) 703-2400
CA	8526	Turner, D. Craig	759 East Monte Vista Avenue	Vacaville	95688	(707) 305-5404
CA	8527	Rodriguez, Abraham	314 Broadway	Oakland	94607	(510) 452-2600
CA	8528	Schubert, Craig	333 South Main Street, Suite A	Red Bluff	96080	(530) 529-5555
CA	8529	Fertows, Farnad	1731 G Street	Arcata	95521	(707) 633-8500
CA	8530	Flaherty, Scott J.	601 McCray Street, Suite #102	Hollister	95023	(831) 637-7788
CA	8531	Patibandla Rao, Malli	829 Harbor Boulevard	W. Sacramento	95691	(916) 302-4000
CA	8533	Elyasi, Mohsen	1033 East Alisal Street, Suite D	Sallinas	93905	(831) 753-7992
CA	8536	Iqbal, Ali Hassan	2766 Aborn Road	San Jose	95121	(408) 270-6000
CA	8537	Tapia, Fernando	Marine Corps Air Ground Combat Center, Bldg 1532 6th Street	Twentynine Palms	92278	(760) 830-1700
CA	8539	Hishmeh, Tareq M.	3431D Macdonald Avenue	Richmond	94805	(510) 232-6300
CA	8540	Ferdows, Farnad	3617 East Foothill Boulevard	Pasadena	91107	(626) 351-6020
CA	8541	Patibandla Rao, Malli	10923 Olson Drive	Rancho Cordova	95670	(916) 822-8999
CA	8542	Patibandla Rao, Malli	723 E. Thousand Oaks Boulevard	Thousand Oaks	91360	(805) 435-8399
CA	8544	Hosseini, Dariush	3388 Palm Avenue, Suite 100	San Diego	92154	(619) 575-4160
CA	8545	Hosseini, Dariush	15817 Bernardo Center Drive, Suite 102	San Diego	92127	(858) 485-0330
CA	8546	Hosseini, Dariush	16605 Sunset Boulevard, Suite 103	Pacific Palisades	90272	(310) 454-1035
CA	8547	Hosseini, Dariush	22972 Moulton Parkway, Suite 102	Laguna Hills	92653	(949) 380-4150
CA	8548	Hosseini, Dariush	1854 Marron Avenue, Suite M-2	Carlsbad	92008	(760) 729-1556
CA	8549	Syriani, Joseph	671 N. State Street	San Jacinto	92583	(951) 654-0506
CA	8550	Hosseini, Dariush	20845 Vandergift Drive, Suite 107	Camp Pendleton	92055	(760) 430-7180
CA	8551	Hosseini, Dariush	Building 5305 Miramar Way Miramar MCAS	San Diego	92145	(858) 530-8750
CA	8552	Hishmeh, Tareq M.	3603 Coffee Road, Suite 100	Bakersfield	93308	(661) 213-3500
CA	8553	Guantes, Juan G. Flores	450 West El Monte Way, Suite A	Dinuba	93618	(559) 595-0555
CA	8554	Hishmeh, Tareq M.	1776 Tuolumne Street	Vallejo	94589	(707) 645-0555
CA	8555	Hosseini, Dariush	8726 Lake Murray Boulevard, Suite C2	San Diego	92119	(619) 465-4123
CA	8556	Hosseini, Dariush	4415 Imperial Avenue, Suite A	San Diego	92113	(619) 264-1000
CA	8557	Brumleve, Dan T.	2745 Hillcrest Avenue	Antioch	94531	(925) 350-4444
CA	8558	Patibandla Rao, Malli	9171 Elk Grove Florin Road, Suite 4	Elk Grove	95624	(916) 686-8800
CA	8559	Patibandla Rao, Malli	8008 Walerga Road, Suite 400	Antelope	95843	(916) 721-0304
CA	8560	Patibandla Rao, Malli	5131 Foothills Boulevard, Suite 7	Roseville	95747	(916) 787-0430
CA	8561	Hosseini, Dariush	415 Santa Fe Drive, Suite #102	Encinitas	92024	(760) 753-1855
CA	8562	Hosseini, Dariush	3707 Avocado Boulevard	La Mesa	91941	(619) 660-9088
CA	8563	Shehadeh, Issa J.	3083 Travis Boulevard	Fairfield	94534	(707) 425-4456
CA	8564	Tapia, Fernando	13297 South Street	Cerritos	90703	(562) 263-3020

Exhibit B Traditional
as of December 31, 2023

CA	8565	Tapia, Fernando	1927 Harbor Boulevard, Suite C	Costa Mesa	92627	(949) 200-3610
CA	8566	Hishmeh, Tareq M.	100 Robles Way, Suite #5	Vallejo	94591	(707) 649-2640
CA	8568	Patibandla Rao, Malli	3119 Broadway	Sacramento	95817	(916) 504-3030
CA	8569	Patibandla Rao, Malli	1901 J Street, Unit C	Sacramento	95816	(916) 504-3399
CA	8570	DeGrandis, Greg	107 West North Street, Suite 101	Manteca	95336	(209) 633-0000
CA	8571	Syriani, Joseph	28039 Scott Road, Unit A	Murrieta	92563	(951) 566-9888
CA	8572	Syriani, Joseph	36520 Temeku Street	Murrieta	92563	(951) 566-0101
CA	8573	Oberg, Jared James	2221 Sunset Boulevard, Suite 123	Rocklin	95765	(916) 672-6630
CA	8574	Hosseini, Dariush	1100 Kincheol Avenue, Bldg. 7210	Edwards AFB	93524	(661) 258-4907
CA	8575	Hosseini, Adam	2621 Green River Road, Suite 104	Corona	92882	(951) 273-1566
CA	8576	Hishmeh, Tareq M.	10 East Washington Street	Petaluma	94952	(707) 762-1000
CA	8577	Ferdows, Farnad	838 Oakdale Road	Modesto	95355	(209) 491-2570
CA	8578	Patibandla Rao, Malli	7385 Greenhaven Drive	Sacramento	95831	(916) 504-4000
CA	8580	Oberg, Jared James	8405 Sierra College Boulevard, Suite A	Roseville	95661	(916) 773-3030
CA	8581	Iqbal, Ali Hassan	2682 Union Avenue	San Jose	95124	(408) 351-4040
CA	8582	Patibandla Rao, Malli	2326 Fair Oaks Boulevard, Suite A	Sacramento	95825	(916) 283-8000
CA	8583	Patibandla Rao, Malli	1500 West El Camino Avenue, Unit 9	Sacramento	95833	(916) 974-4400
CA	8584	Patibandla Rao, Malli	421 Blue Ravine Road, Suite 300	Folsom	95630	(916) 983-3003
CA	8585	Shehadeh, Issa J.	461 Skymaster Circle, Building 650	Travis AFB	94535	(707) 419-6100
CA	8586	Hosseini, Dariush	3451 Via Montebello, Suite 186	Carlsbad	92009	(760) 704-0050
CA	8587	Ferdows, Farnad	1630 E. Hatch Road, Suite E	Modesto	95351	(209) 541-1887
CA	8588	Turner, D. Craig	305 S. Hutchins Street	Lodi	95240	(209) 625-1234
CA	8589	Hishmeh, Tareq M.	975 Diablo Avenue, Space No. 102 A	Novato	94947	(415) 878-5555
CA	8591	Gobrial, Nehad E.	1501 Corporate Drive	Ladera Ranch	92694	(949) 481-6333
CA	8592	La Mountain, Doyle	1136 N. Mt. Vernon, Space 101	San Bernardino	92411	(909) 361-4821
CA	8593	Patibandla Rao, Malli	4540 Florin Road, Suite B	Sacramento	95823	(916) 254-5000
CA	8594	Patibandla Rao, Malli	1170 E. Champlain Avenue, Suite 101	Fresno	93720	(559) 412-2010
CA	8595	Hosseini, Dariush	4360 Bonita Road	Bonita	91902	(619) 419-1800
CA	8596	Hosseini, Dariush	126 W. Washington Street, Suite A	San Diego	92103	(619) 881-8800
CA	8597	Hosseini, Dariush	13624 Poway Road, Suite 120	Poway	92064	(658) 375-7575
CA	8657	Hosseini, Dariush	MCRD Recreation Center, 3806 Chosin Avenue	San Diego	92140	(619) 344-0850
CA	8680	Patibandla Rao, Malli	9427 Madison Avenue	Orangevale	95662	(916) 283-3075
CA	8681	Hishmeh, Tareq M.	100 Dixon Road	Milpitas	95035	(669) 238-4300
CA	8682	Hosseini, Dariush	6622 Irvine Center Drive	Irvine	92618	(657) 261-7272
CA	8683	Hosseini, Dariush	934 S. Harbor Boulevard	Santa Ana	92704	(657) 335-4500
CA	8684	Patibandla Rao, Malli	9527 Folsom Boulevard, Suite A	Sacramento	95827	(916) 330-2100
CA	8685	Patibandla Rao, Malli	4401 Gateway Park Boulevard, Suite 120	Sacramento	95834	(916) 246-4100

Exhibit B Traditional
as of December 31, 2023

CA	8686	Patibandla Rao, Malli	4720 Elk Grove Boulevard, Suite 180	Elk Grove	95758	(916) 684-3333
CA	8687	Hishmeh, Tareq M.	10400 Community Loop	Vandenberg AFB	93437	(805) 741-3777
CA	8688	Ferdows, Farnad	1419 Standford Avenue, Suite 1	Modesto	95350	(209) 593-2121
CA	8689	Patibandla Rao, Malli	3000 Green Valley Road, Suite 16	Cameron Park	95682	(530) 672-8700
CA	8690	Ferdows, Farnad	2220 East Pacheco Boulevard, Suite A	Los Banos	93635	(209) 737-0840
CA	8691	Turner, D. Craig	2233 Grand Canal Boulevard, Suite 202	Stockton	95207	(209) 451-0050
CA	8692	Schwesinger, Dennis E.	27530 Newhall Ranch Road, Suite 107	Valencia	91355	(661) 271-2700
CA	8693	Manos, Anthony P.	1315 Long Beach Boulevard	Long Beach	90813	(562) 270-7030
CA	8694	Patibandla Rao, Malli	3307 N. Cedar Avenue	Fresno	93726	(559) 353-2939
CA	8695	Tapia, Fernando	82-900 Avenue 42, Suite F101	Indio	92203	(760) 972-4766
CA	8696	DeGrandis, Greg	4120 Chiles Road, Suite B	Davis	95618	(530) 204-1212
CA	8697	Hishmeh, Tareq M.	14350 Laurie Lane, Suite K	San Pablo	94806	(510) 556-5100
CA	8699	Tapia, Fernando	12130 Hesperia Road, Suite A	Victorville	92395	(760) 503-5911
CO	6195	Hamill, R. Brent	12302 East 104th Place, Unit 101	Commerce City	80022	(303) 577-3030
CO	6200	Hamill, R. Brent	6709 W. Coal Mine Avenue, Unit C/103	Littleton	80123	(303) 703-9494
CO	6201	Hamill, R. Brent	2101 South Downing Street	Denver	80210	(303) 777-6655
CO	6202	Hamill, R. Brent	906-910 S. Sheridan Boulevard	Denver	80226	(303) 922-6293
CO	6203	Rea, Michael S.	3920 S. Broadway	Englewood	80113	(303) 781-6647
CO	6204	Hamill, R. Brent	7205 West Colfax Avenue, Suite 101B	Lakewood	80214	(303) 232-1447
CO	6205	Haydon, James B.	2600 East Street, Suite D	Golden	80401	(303) 278-7241
CO	6206	Hamill, R. Brent	2926-2930 W. Jewell Avenue	Denver	80219	(303) 935-3556
CO	6207	Hamill, R. Brent	3890 Kipling Street, Unit B	Wheat Ridge	80033	(303) 431-5555
CO	6208	Hamill, R. Brent	2917 West 38th Avenue	Denver	80211	(303) 458-0567
CO	6209	Hamill, R. Brent	2585 S. Lewis Way, Unit A	Lakewood	80227	(303) 988-4795
CO	6210	Hamill, R. Brent	796 E. Kiowa Avenue, Unit H-10	Elizabeth	80107	(303) 954-8022
CO	6211	Rea, Michael S.	1136 S. Colorado Boulevard	Glendale	80246	(303) 758-8050
CO	6212	Rea, Michael S.	91 W Mineral Avenue	Littleton	80120	(303) 797-7889
CO	6213	Rea, Michael S.	15355 E Colfax Avenue	Aurora	80011	(303) 360-9091
CO	6214	Rea, Michael S.	12405 E. Mississippi Avenue	Aurora	80012	(303) 696-8777
CO	6215	Rea, Michael S.	5698 S. Himalaya Street	Aurora	80015	(303) 693-9993
CO	6216	Rea, Michael S.	7115 E Hampden Avenue, Suite #C	Denver	80224	(303) 758-4444
CO	6217	Rea, Michael S.	15281 E Mississippi	Aurora	80012	(303) 751-9500
CO	6218	Rea, Michael S.	5210 E. Arapahoe Road	Centennial	80122	(303) 779-8877
CO	6219	Rea, Michael S.	10909 E. Arapahoe Place #105	Centennial	80112	(303) 779-8202
CO	6220	Rea, Michael S.	18707 E. Hampden Avenue	Aurora	80013	(303) 693-7696
CO	6221	Rea, Michael S.	8031 E. Colfax Avenue	Denver	80220	(303) 355-5551
CO	6222	Dolan, Charles S.	5804 Ward Road, Unit A	Arvada	80002	(303) 423-5553

Exhibit B Traditional
as of December 31, 2023

CO	6223	Dolan, Charles S.	10350 Federal Boulevard, Suite 100	Federal Heights	80260	(303) 426-9815
CO	6224	Dolan, Charles S.	8757 Wadsworth Boulevard	Arvada	80003	(303) 425-0993
CO	6225	Prellwitz, Philip	1119 Eagle Drive	Loveland	80537	(970) 669-8512
CO	6226	Feavel, Jay B.	3521 W. 10th Street	Greeley	80634	(970) 353-6500
CO	6227	Hamill, R. Brent	12870 Stroh Ranch Court	Parker	80534	(720) 821-3030
CO	6228	Hamill, R. Brent	5159 W 120th Avenue	Broomfield	80020	(303) 466-4664
CO	6229	Rea, Michael S.	4030 Colorado Boulevard, Suite 102	Denver	80216	(303) 377-5858
CO	6230	Feavel, Jay B.	7008 10th Street, Suite 300	Greeley	80634	(970) 573-7070
CO	6231	Hamill, R. Brent	1538 28th Street	Boulder	80303	(303) 449-9080
CO	6232	Hamill, R. Brent	1106 Main Street	Longmont	80501	(303) 772-3030
CO	6233	Hamill, R. Brent	558 Castle Pines Parkway, Suite 81	Castle Rock	80108	(720) 738-3030
CO	6234	Prellwitz, Philip	1385 Sculptor Drive	Loveland	80537	(970) 663-2880
CO	6235	Feavel, Jay B.	2110 W. Elizabeth Street	Fort Collins	80521	(970) 484-3030
CO	6236	Hamill, R. Brent	5801 West 44th Avenue, Unit F	Lakeside	80212	(303) 248-3630
CO	6237	Feavel, Jay B.	2412 8th Avenue	Greeley	80631	(970) 351-6771
CO	6238	Feavel, Jay B.	901 E. Harmony Road, Unit 120	Fort Collins	80525	(970) 226-3030
CO	6239	Hamill, R. Brent	3941 East 120th Avenue	Thornton	80233	(303) 450-6262
CO	6240	Hamill, R. Brent	2400 East 88th, Unit L	Denver	80229	(303) 288-5522
CO	6241	Hamill, R. Brent	627 Ken Pratt Boulevard	Longmont	80501	(720) 727-8143
CO	6242	Hamill, R. Brent	2120 Village Vista Drive, Unit 140	Erie	80516	(720) 604-1261
CO	6243	Hamill, R. Brent	11757 W. Ken Caryl Avenue, Unit C	Littleton	80127	(303) 972-4600
CO	6244	Prellwitz, Philip	1018 Mahogany Way, Unit A	Severance	80550	(970) 710-6424
CO	6245	Hamill, R. Brent	5171 W. 64th Avenue	Arvada	80003	(303) 650-6464
CO	6246	Williams, Craig K.	9673 Prominent Point, Suite 100	Colorado Springs	80924	(719) 434-9996
CO	6247	Hamill, R. Brent	6545 Gunpark Drive, Suite 210	Boulder	80301	(303) 498-0750
CO	6248	Hamill, R. Brent	9906 West Belleview Avenue	Littleton	80123	(303) 972-9792
CO	6249	Haydon, James B.	11102 W Colfax Avenue	Lakewood	80215	(303) 235-0353
CO	6250	Feavel, Jay B.	3304 37th Street, Unit 4	Evans	80620	(970) 515-3130
CO	6251	Williams, Craig K.	1737 B Street	Colorado Springs	80906	(719) 576-3850
CO	6252	Williams, Craig K.	1102 N. Circle Drive	Colorado Springs	80909	(719) 475-0380
CO	6253	Williams, Craig K.	6890 Mesa Ridge Parkway	Fountain	80917	(719) 390-7901
CO	6254	Williams, Craig K.	1823 S Nevada Avenue	Colorado Springs	80905	(719) 475-0945
CO	6255	Williams, Craig K.	5168 N. Academy	Colorado Springs	80918	(719) 599-9200
CO	6256	Burgess, Timothy Kent	6870 Galley Road	Colorado Springs	80915	(719) 574-0950
CO	6257	Burgess, Timothy Kent	330 North Wahsatch	Colorado Springs	80903	(719) 444-8888
CO	6258	Burgess, Timothy Kent	3025 Jet Wing Drive	Colorado Springs	80916	(719) 390-5066
CO	6259	Williams, Craig K.	205 West Rockrimmon Boulevard, Suite C	Colorado Springs	80919	(719) 260-9595

Exhibit B Traditional
as of December 31, 2023

CO	6260	Burgess, Timothy Kent			204 Mount View Lane, Suite #14	Colorado Springs	80907	(719) 598-8800
CO	6261	Williams, Craig K.			3302 W Colorado Avenue	Colorado Springs	80904	(719) 633-3500
CO	6262	Williams, Craig K.			7055 Lexington Boulevard	Colorado Springs	80920	(719) 594-0400
CO	6263	Williams, Craig K.			6033 Barnes Road	Colorado Springs	80922	(719) 574-3900
CO	6265	Burgess, Timothy Kent			2404 S. Glen Avenue	Glenwood Springs	81601	(970) 945-0330
CO	6266	Haydon, James B.			324 U.S. Highway 6 #20	Dillon	80435	(970) 468-7744
CO	6267	Haydon, James B.			255 Anglers Drive, Building B, Suite C	Steamboat Springs	80487	(970) 879-4811
CO	6268	Hamill, R. Brent			484 Crystal Valley Parkway #103	Castle Rock	80104	(720) 504-9441
CO	6270	Williams, Craig K.			1830 Main Street, Suite 130	Colorado Springs	80911	(719) 301-7778
CO	6271	Burgess, Timothy Kent			1501 S. Prairie Avenue	Pueblo	81005	(719) 561-9300
CO	6272	Burgess, Timothy Kent			2250 Santa Fe Drive	Pueblo	81006	(719) 545-2211
CO	6273	Burgess, Timothy Kent			200 W. 29th Street	Pueblo	81008	(719) 545-5555
CO	6274	Haydon, James B.			25597 Conifer Road	Conifer	80433	(720) 770-1212
CO	6275	Burgess, Timothy Kent			1003 Royal Gorge Boulevard	Canon City	81212	(719) 275-1631
CO	6276	Dolan, Charles S.			1407 W. 84th Avenue, Suite D3b	Denver	80260	(720) 774-6226
CO	6277	Haydon, James B.			51 Beaver Creek Place	Avon	81620	(970) 949-3230
CO	6278	Bailey, Brian K.			1 Conley Road	La Junta	81050	(719) 316-3030
CO	6279	Feavel, Jay B.			4650 Signal Tree Drive, Unit 1700, Bldg. A	Timneth	80547	(970) 295-4990
CO	6280	Whiting, Troy A.			904 North Avenue	Grand Junction	81501	(970) 245-4545
CO	6281	Hamill, R. Brent			640 Malley Drive	Northglenn	80233	(720) 677-4443
CO	6282	Prellwitz, Philip			4184 Saint Cloud Drive, Suite 104	Loveland	80538	(970) 541-2330
CO	6283	DelGrosso, Brian			701 W. Main Street	Sterling	80538	(970) 522-3030
CO	6284	DelGrosso, Brian			1107 W. Platte Avenue	Fort Morgan	80701	(970) 867-3030
CO	6285	Dolan, Charles S.			14749 W 87th Parkway, Unit F	Arvada	80005	(720) 798-4500
CO	6286	Hamill, R. Brent			956 W. Cherry Street, Suite 104B	Louisville	80027	(303) 665-0300
CO	6287	Burgess, Timothy Kent			108 Lincoln Street, Suite A	Pueblo	81004	(719) 225-2227
CO	6288	Bailey, Brian K.			1185 S. Camino Del Rio #160	Durango	81303	(970) 478-3030
CO	6289	Burgess, Timothy Kent			811 E. Main Street	Montrose	81401	(970) 249-2314
CO	6290	Bailey, Brian K.			1485 Florida Road, Building A, Suite 101	Durango	81301	(970) 259-3660
CO	6291	Bailey, Brian K.			1109 6th Street	Alamosa	81101	(719) 589-9091
CO	6292	Hamill, R. Brent			10471 S. Parker Road, Unit 1C	Parker	80134	(303) 840-4561
CO	6293	Burgess, Timothy Kent			2249 Broadway, Unit 102A	Grand Junction	81507	(970) 243-3639
CO	6294	Whiting, Troy A.			510 30 Road	Grand Junction	81504	(970) 241-3733
CO	6296	Burgess, Timothy Kent			2674 Highway 50	Grand Junction	81503	(970) 241-1513
CO	6297	Hamill, R. Brent			3460 Park Avenue West, Suite E	Denver	80216	(303) 716-1616
CO	6299	Hamill, R. Brent			18630 E. 48th Avenue	Denver	80249	(303) 969-9999
CO	6331	Williams, Craig K.			7408 Black Forest Road	Colorado Springs	80923	(719) 466-8993

Exhibit B Traditional
as of December 31, 2023

CO	6332	Williams, Craig K.		13461 Voyager Parkway	Colorado Springs	80921	(719) 481-4100
CO	6334	Haydon, James B.		1153 Bergen Parkway	Evergreen	80439	(303) 674-3030
CO	6335	Bailey, Brian K.		720 North Main Street	Gunnison	81230	(970) 707-4199
CO	6336	Osita, Richard Kenechukwu		78415 US 40	Winter Park	80482	(970) 363-6001
CO	6337	Haydon, James B.		1111 W. Victory Way, Suite 124	Craig	81625	(970) 824-4855
CO	6338	Smith, Zachary Austin		1089 Highway 133	Carbondale	81623	(970) 704-0330
CO	6339	Prelwitz, Philip		1555 Main Street, Suite A-1	Windsor	80550	(970) 686-5500
CO	6342	Hamill, R. Brent		1280 Grant Street	Denver	80203	(303) 831-4242
CO	6344	Bailey, Brian K.		350 Stafford Lane, Suite 3512	Delta	81416	(970) 874-5678
CO	6348	Burgess, Timothy Kent		1248 Railroad Road	Rifle	81650	(970) 625-0505
CO	6349	Hamill, R. Brent		4701 Peoria Street, Suite 116	Denver	80239	(303) 576-0065
CO	6353	Feavel, Jay B.		732 S. Lemay, Suite A	Fort Collins	80524	(970) 407-1073
CO	6354	Hamill, R. Brent		3100 S. Sheridan Boulevard	Denver	80227	(720) 896-7040
CO	6355	Williams, Craig K.		605 West Midland Avenue	Woodland Park	80863	(719) 687-5310
CO	6356	Hamill, R. Brent		9579 S. University Boulevard, Suite 130	Highlands Ranch	80126	(720) 348-1222
CO	6357	Hamill, R. Brent		530 East Bromley Lane, Suite 110	Brighton	80601	(720) 685-3334
CO	6358	Feavel, Jay B.		1880 N. College Avenue	Ft. Collins	80525	(970) 449-0676
CO	6359	Burgess, Timothy Kent		101 South McCulloch Boulevard	Pueblo	81007	(719) 547-1444
CO	6362	Burgess, Timothy Kent		225 E. Aspen Avenue, Unit B	Fruita	81521	(970) 858-2302
CO	6363	Bailey, Brian K.		2224 East Main Street	Cortez	81321	(970) 565-7373
CO	6365	Williams, Craig K.		7376 McLaughlin Road, Unit K	Falcon	80831	(719) 494-1899
CO	6366	Smith, Zachary Austin		457 E. Wonderview Avenue, Unit C2	Estes Park	80517	(970) 586-8181
CO	6367	Hamill, R. Brent		695 Jerry Street, Suite 108	Castle Rock	80104	(303) 660-1222
CO	6368	Burgess, Timothy Kent		401 E. Main Street, Suite E	Florence	81226	(719) 784-4503
CO	6369	Burgess, Timothy Kent		481 Highway 105, Suite 200	Monument	80132	(719) 219-0603
CO	6370	DelGrosso, Brian		11078 Cimarron Street, Unit 5A	Firestone	80504	(303) 684-0123
CO	6371	Hamill, R. Brent		3335 Arapahoe Road #20	Erie	80516	(303) 664-5111
CO	6372	DelGrosso, Brian		1200 Dexter Street, Unit W-8	Fort Lupton	80621	(303) 857-1201
CO	7641	Burgess, Timothy Kent		1002 N. Market Plaza, Unit G	Pueblo West	81007	(719) 507-3633
CO	7671	Osita, Richard Kenechukwu		1141 Thompson Road, Unit #104	Granby	80446	(970) 364-0070
CO	8600	DelGrosso, Brian		28 S. Parish Street	Johnstown	80534	(970) 587-7887
CO	8650	DelGrosso, Brian		7670 5th Street	Wellington	80549	(970) 568-4336
CO	8651	Bailey, Brian K.		150 East U.S. Highway 50	Salida	81201	(719) 539-1999
CO	8652	Burgess, Timothy Kent		28 Cardinal Way	Parachute	81635	(970) 285-9296
CO	8653	Bailey, Brian K.		12916 Highway 24/285, Unit B	Buena Vista	81211	(719) 395-3331
CO	8654	Black, Kimberly Rae		22651 E. Aurora Parkway, #6	Aurora	80016	(303) 617-3030
CO	8655	Hamill, R. Brent		11800 Oswego Street, Unit D25	Englewood	80112	(303) 662-1900

Exhibit B Traditional
as of December 31, 2023

CO	8656	Burgess, Timothy Kent	150 Cooley Mesa Road, Suite A	Gypsum	81637	(970) 777-0330
CO	8658	Preilwitz, Philip	237 W. 64th Street	Loveland	80538	(970) 685-4075
CO	8659	Rea, Michael S.	365 N. Telluride, Mail Stop 76	Buckley AFB Aurora	80011	(303) 367-3008
CO	8660	Rea, Michael S.	550 E. Colfax Avenue	Bennett	80102	(303) 644-4400
CO	8661	Hamill, R. Brent	13644 Orchard Parkway, Suite 500	Westminster	80234	(720) 460-3555
CO	8662	Preilwitz, Philip	201 S. Elm. Avenue, Units 209 & 210	Eaton	80615	(970) 612-9200
CO	8663	Haydon, James B.	8351 North Rampart Range Road, Unit C-107	Littleton	80125	(720) 575-7272
CO	8664	Williams, Craig K.	1510 Chiles Avenue	Fort Carson	80913	(719) 377-6868
CO	8665	Rea, Michael S.	4260 South Chambers Road	Aurora	80014	(720) 542-8897
CO	8666	Williams, Craig K.	2302 Cadet Drive, Bldg. 2302	US Air Force Academy	80840	(719) 434-9989
CO	8667	Hamill, R. Brent	7505 E. 35th Street, Suite 305	Denver	80238	(303) 322-3448
CO	8668	Bailey, Brian K.	416 University Street	Trinidad	81082	(719) 259-3030
CO	8669	Rea, Michael S.	8450 East Iliff Avenue, Unit #3	Denver	80231	(303) 353-4045
CT	3279	Amaral, Nuno M.	242 Greenmanville Road	Stonington	06378	(860) 572-8030
CT	3282	Mogul, Nancy	1070 N. Main Street	Dayville	06241	(860) 774-4442
CT	3283	Farid, Syed Humayun	200 Main Street	Southington	06489	(860) 620-9500
CT	3397	Chowdhury, Rahman	95 South Main Street	Torrington	06790	(860) 618-7000
CT	3919	Ansari, Massoud	850 Bridgeport Avenue	Shelton	06484	(203) 805-7000
CT	3926	Uddin, Mohammed J.	600 North Colony Road	Wallingford	06492	(203) 284-0500
CT	3927	Ahmad, Nasir U.	144 Oxford Road	Oxford	06478	(203) 881-6567
CT	3928	Warren, Neil A.	36 Windsor Avenue	Vernon	06066	(860) 870-4545
CT	3933	Warren, Neil A.	2 Middle River Drive	Stafford	06076	(860) 458-3332
CT	4000	Prior, Lee S.	266 East Main Street	Clinton	06413	(860) 552-4829
CT	4001	Cookston, Robert L. III	1523-B Stanley Street	New Britain	06053	(860) 225-6644
CT	4002	Chowdhury, Rahman	699 Park Avenue	Bloomfield	06002	(860) 969-4777
CT	4003	Chowdhury, Rahman	312 Farmington Avenue	Hartford	06105	(860) 246-8333
CT	4005	Chowdhury, Rahman	738 Maple Avenue	Hartford	06114	(860) 548-0050
CT	4007	Warren, Neil A.	1143-C New Britain Avenue	W. Hartford	06119	(860) 232-4000
CT	4009	Mogul, Nancy	920 Enfield Street	Enfield	06082	(860) 265-2424
CT	4010	Warren, Neil A.	23 Main Street	Manchester	06042	(860) 645-6000
CT	4011	Islam, Mohammed D	775 Silver Lane, Unit 2A	East Hartford	06118	(860) 569-1700
CT	4012	Warren, Adam Michael	812 Highland Avenue	Waterbury	06708	(203) 437-7177
CT	4015	Chowdhury, Rahman	45 Palisado Avenue	Windsor	06095	(860) 688-6313
CT	4020	Warren, Adam Michael	158 Manor Avenue	Waterbury	06705	(203) 755-8110
CT	4024	Iqbal, Mohammed	500 S. Main Street	Naugatuck	06770	(203) 723-6653
CT	4025	Ahmad, Nasir U.	57 Turnpike Square	Milford	06460	(203) 877-4040
CT	4027	Ahmad, Nasir U.	116 Boston Post Road	Orange	06477	(203) 933-4040

Exhibit B Traditional
as of December 31, 2023

CT	4029	Uddin, Mohammed J.			9 Foxon Boulevard	East Haven	06513	(203) 467-1361
CT	4030	Ansari, Massoud			41 Main Street	New Milford	06776	(860) 540-4000
CT	4033	Uddin, Mohammed J.			470 Whalley Avenue	New Haven	06511	(203) 624-3317
CT	4035	Uddin, Mohammed J.			2545 Whitney Avenue	Hamden	06518	(203) 288-3800
CT	4036	Bhatti, Zafeer Ahmed			142 East Putnam Avenue	Cos Cob	06807	(203) 661-2202
CT	4039	Ahmad, Nasir U.			137-139 N. Main Street	Ansonia	06401	(203) 732-3030
CT	4041	Cookston, Robert L. III			2308 Main Street	Bridgeport	06606	(203) 334-3030
CT	4042	Bhatti, Zafeer Ahmed			1580 Post Road	Fairfield	06430	(203) 255-8823
CT	4044	Ansari, Massoud			36 Tamarack Avenue	Danbury	06811	(203) 790-7700
CT	4046	Cookston, Robert L. III			301 Main Avenue	Norwalk	06851	(203) 846-4646
CT	4047	Cookston, Robert L. III			946 Hope Street	Stamford	06907	(203) 324-7771
CT	4050	Amaral, Nuno M.			314 Route 12	Groton	06340	(860) 449-9135
CT	4051	Amaral, Nuno M.			939 Bank Street	New London	06320	(860) 442-9383
CT	4052	Elmeer, Andrew M.			370 South Main Street	Middletown	06457	(860) 704-0606
CT	4053	Massey, Mark H.			20 New London Turnpike	Norwich	06360	(860) 887-4567
CT	4055	Iqbal, Mohammed			172 W. Main Street	Meriden	06451	(203) 630-3030
CT	4058	Iqbal, Mohammed			656 Farmington Avenue	Bristol	06010	(860) 582-5100
CT	4060	Warren, Neil A.			241 Valley Street	Willimantic	06226	(860) 456-0306
CT	4062	Cookston, Robert L. III			1980 W. Main Street	Stamford	06902	(203) 324-5600
CT	4065	Warren, Neil A.			1244 Storrs Road	Storrs	06268	(860) 429-7969
CT	4067	Amaral, Nuno M.			1920 Route 32, Suite B	Uncasville	06382	(860) 237-3993
CT	4068	Kabir, Ibrahim			397 Cromwell Avenue	Rocky Hill	06067	(860) 721-8600
CT	4070	Cookston, Robert L. III			1802 Barnum Avenue	Straford	06497	(203) 380-8400
CT	4071	Uddin, Mohammed J.			56 Lathrop Road	Plainfield	06374	(860) 564-9933
CT	9530	Issa, Shovon			46 East Street	Plainville	06062	(860) 846-0014
CT	9531	Mogul, Nancy			52 Rainbow Road	Granby	06026	(860) 413-3499
CT	9532	Issa, Shovon			544 Deming Street	Berlin	06037	(860) 438-7895
CT	9533	Warren, Adam Michael			1044 Main Street	Watertown	06795	(860) 274-0808
CT	9535	Cookston, Robert L. III			4310 Main Street	Bridgeport	06644	(203) 372-3030
CT	9536	Ansari, Massoud			286 Greenwood Avenue	Bethel	06801	(203) 748-3300
DC	4326	O'Neill, Louis C.			900 M Street SE	Washington	20003	(202) 484-3030
DC	4328	O'Neill, Louis C.			2701 14th Street NW	Washington	20009	(202) 232-8400
DC	4329	O'Neill, Louis C.			1335 2nd Street NE	Washington	20002	(202) 526-8600
DC	4330	O'Neill, Louis C.			2330 Wisconsin Avenue NW	Washington	20007	(202) 342-0100
DC	4331	O'Neill, Louis C.			4539 Wisconsin Avenue NW	Washington	20016	(202) 362-7500
DC	4335	O'Neill, Louis C.			208 Michigan Avenue NE	Washington	20017	(202) 832-3343
DC	4336	O'Neill, Louis C.			1300 L Street NW	Washington	20005	(202) 639-8700

Exhibit B Traditional
as of December 31, 2023

DC	4344	O'Neill, Louis C.			2029 K Street NW	Washington	20006	(202) 223-1100
DC	4362	O'Neill, Louis C.			6239 Georgia Avenue NW	Washington	20011	(202) 291-6100
DE	4401	Khan, Mohammad S.			60 N. College Avenue	Newark	19711	(302) 369-1100
DE	4402	Khan, Mohammad S.			12 Polly Drummond Hill Road	Newark	19711	(302) 738-2200
DE	4403	Khan, Mohammad S.			2425 Pulaski Highway	Newark	19702	(302) 738-0440
DE	4404	Khan, Mohammad S.			1202 Delaware Street	New Castle	19720	(302) 323-1515
DE	4405	Khan, Mohammad S.			20 Salem Village Square, Unit 3	Newark	19713	(302) 454-0330
DE	4406	Khan, Mohammad S.			797 Pulaski Highway	Bear	19701	(302) 836-3300
DE	4419	Prouse, Donald M. Jr.			23437 Sussex Highway	Seaford	19973	(302) 628-5000
DE	4420	Khan, Mohammad S.			4528C Kirkwood Highway	Wilmington	19808	(302) 994-3030
DE	4422	Khan, Mohammad S.			1728 Marsh Road	Wilmington	19810	(302) 479-5900
DE	4423	Khan, Mohammad S.			401 S. Market Street	Wilmington	19801	(302) 524-1010
DE	4424	Prouse, Donald M. Jr.			26396 Bay Farm Road, Unit #7	Millsboro	19966	(302) 945-5000
DE	4425	Khan, Mohammad S.			7465 Lancaster Pike	Hookessin	19707	(302) 307-3333
DE	4435	Prouse, Donald M. Jr.			105 Aerenson Drive	Milford	19963	(302) 424-4444
DE	4436	Boyd, James A.			132 Broad Kill Road	Milton	19968	(302) 684-5000
DE	4438	Prouse, Donald M. Jr.			261 N. DuPont Highway, Suite #4	Dover	19901	(302) 735-3333
DE	4440	Prouse, Donald M. Jr.			4 Jerome Drive	Dover	19901	(302) 674-1111
DE	4441	Prouse, Donald M. Jr.			374 Walmart Drive, Unit 5	Camden	19934	(302) 697-8888
DE	4442	Prouse, Donald M. Jr.			230 E. Glenwood Avenue	Smyrna	19977	(302) 653-3333
DE	4443	Prouse, Donald M. Jr.			20775 Dupont Boulevard	Georgetown	19947	(302) 855-9000
DE	4445	Prouse, Donald M. Jr.			1000 Midway Drive, Suite 1	Harrington	19952	(302) 398-4400
DE	4446	Khan, Mohammad S.			4416 Summit Bridge Road	Middletown	19709	(302) 376-7000
DE	4466	Prouse, Donald M. Jr.			123 East DuPont Highway	Millsboro	19966	(302) 934-8000
DE	4467	Barber, John C.			17884 Coastal Highway, Unit #3	Lewes	19958	(302) 604-5200
DE	4477	Prouse, Donald M. Jr.			30182 Sussex Highway, Unit 1	Laurel	19956	(302) 875-1000
DE	4494	Khan, Mohammad S.			2472 N. Dupont Highway	Middletown	19709	(302) 440-4400
DE	4497	Khan, Mohammad S.			504 Kirkwood Highway	Elsmere	19805	(302) 990-2000
FL	3100	Welker, William L.			5140 County Line Road, Unit 2	Lakeland	33811	(863) 345-3030
FL	3109	Longen, Jerry A.			10052 Cross Creek Boulevard	Tampa	33647	(813) 907-7729
FL	3110	Welker, William L.			5050 Gall Boulevard	Zephyrhills	33541	(813) 779-7900
FL	3112	Sheikh, Ahsan M.			96118 Lofton Square, Suite 5	Yulee	32097	(904) 491-3400
FL	3113	Zdanowicz, Paul J.			490 US Highway 27 N, Suite 1360	Lake Placid	33852	(863) 699-0444
FL	3115	Sheikh, Ahsan M.			4158 W. County Road 218	Middleburg	32068	(904) 282-0234
FL	3116	Pichardo, Franklin L.			1933 Ortega Street	Navarre	32566	(850) 939-6995
FL	3117	Welker, William L.			4660 County Road 540-A	Lakeland	33813	(863) 519-7070
FL	3118	May, Roy Jeffrey			13019 Sorrento Road	Pensacola	32507	(850) 492-7610

Exhibit B Traditional
as of December 31, 2023

FL	3119	Welker, William L.	1709 Shepherd Road	Lakeland	33811	(863) 648-0606
FL	3120	Longen, Jerry A.	2372 West US Highway 90	Lake City	32055	(386) 758-3130
FL	3123	Mullins, Erin M.	9860 Stringfellow Road	St. James City	33956	(239) 283-8030
FL	3124	Ramia, Jose Y.	27900 U.S. Highway 27 South	Leesburg	34748	(352) 805-2311
FL	3125	Magnes, Scott J.	2703 Gulf Breeze Parkway	Gulf Breeze	32563	(850) 932-4666
FL	3126	Rice, Derek Robert	7670 N. Wickham Road	Melbourne	32934	(321) 254-1166
FL	3127	Calixto, Facundo	5045 Soutel Drive #14	Jacksonville	32208	(904) 765-2411
FL	3130	Price, Richard W.	1620 Clearlake Road	Cocoa	32922	(321) 636-4311
FL	3132	Welker, William L.	40230 US Highway 27, Suite 180	Davenport	33837	(863) 419-1999
FL	3133	Longen, Jerry A.	7805 Palm River Road	Tampa	33619	(813) 563-9009
FL	3134	Sheikh, Ahsan M.	1560-2 Business Center Drive	Orange Park	32003	(904) 278-3233
FL	3136	Nagengast, Michael P.	450092 SR 200 #7B	Callahan	32011	(904) 879-5211
FL	3137	Ceide, Richard T.	18735 East Colonial Drive, Units 112 & 212	Orlando	32820	(407) 568-3330
FL	3139	Ceide, Richard T.	3863 S Nova Road	Port Orange	32127	(386) 287-3500
FL	3140	Sheikh, Ahsan M.	2220 County Road 210 W #103	Jacksonville	32259	(904) 825-3633
FL	3142	Sheikh, Ahsan M.	111 Flagler Plaza Drive	Palm Coast	32137	(386) 439-0565
FL	3143	Longen, Jerry A.	5113 State Road 674, Suite 17	Wimauma	33598	(813) 755-6800
FL	3146	Longen, Jerry A.	1474 South 6th Street	Macclenny	32063	(904) 259-1600
FL	3148	Longen, Jerry A.	23388 State Road 54 #101	Lutz	33549	(813) 909-1130
FL	3149	Welker, William L.	11930 Narcoossee Road	Orlando	32832	(407) 919-6161
FL	3150	Welker, William L.	1231 Ariana Street	Lakeland	33803	(863) 777-5035
FL	3152	Jandrew, Brian K.	1660 S. Congress Avenue, Suite 7	Boynton Beach	33426	(561) 600-4999
FL	3153	Jandrew, Brian K.	1700 W. 45th Street, Suite 1800	West Palm Beach	33407	(561) 570-5030
FL	3154	Vivas, Gaston	537 US Highway 41 Bypass N.	Venice	34285	(941) 484-3030
FL	3156	Longen, Jerry A.	1990 Pat Thomas Parkway	Quincy	32351	(850) 875-8300
FL	3158	Longen, Jerry A.	2657 East Lake Road, Unit T-2	Palm Harbor	34685	(727) 477-1515
FL	3159	Welker, William L.	13220 Starkey Road, Suite 100	Largo	33773	(727) 530-3335
FL	3160	Diaz, Nelson	2712 S. Chickasaw Trail	Orlando	32829	(407) 384-8686
FL	3161	Bialock, William D. III	4795 Fay Boulevard	Cocoa	32927	(321) 632-6781
FL	3162	Sheikh, Ahsan M.	5025 San Jose Boulevard	Jacksonville	32207	(904) 731-8282
FL	3163	Diaz, Nelson	5285 Red Bug Lake Road #117	Winter Springs	32708	(407) 695-2956
FL	3165	Price, Richard W.	3054 W. New Haven Avenue	West Melbourne	32904	(321) 952-3030
FL	3167	Zdanowicz, Paul J.	1332 E. Oak Street	Arcadia	34226	(863) 993-3737
FL	3168	Andrade, Cesar L.	180 Crandon Boulevard	Key Biscayne	33149	(305) 361-0000
FL	3171	May, Roy Jeffrey	8900 Pine Forest Road	Pensacola	32534	(850) 741-2779
FL	3172	Longen, Jerry A.	5750 SW 75th Court, Unit No. 40	Gainesville	32608	(352) 373-8888
FL	3173	Reulbach, Anthony S.	828-7 Saxon Boulevard	Orange City	32763	(386) 775-7575

Exhibit B Traditional
as of December 31, 2023

FL	3174	Welker, William L.	316 Havendale Boulevard	Auburndale	33823	(863) 280-6900
FL	3175	Sheikh, Ahsan M.	219 Street Joe Plaza Drive	Palm Coast	32164	(386) 445-6500
FL	3176	Pichardo, Franklin L.	1049 S. Ferdon Boulevard	Crestview	32536	(850) 682-5495
FL	3178	Lopez Velarde, Nefi Fernando Padilla	2108 Bruton Boulevard	Orlando	32805	(407) 648-8899
FL	3179	Sheikh, Ahsan M.	3501-E North Ponce De Leon Boulevard	St. Augustine	32084	(904) 824-0802
FL	3187	Sheikh, Ahsan M.	8450 Argyle Forest Boulevard, Unit #9	Jacksonville	32244	(904) 779-7755
FL	3213	Longen, Jerry A.	25 NW 16th Avenue	Gainesville	32601	(352) 373-5555
FL	3214	Longen, Jerry A.	3309 West University Avenue	Gainesville	32607	(352) 377-4992
FL	3228	Lewis, Thomas R.	3611-1 Street Johns Bluff Road South	Jacksonville	32224	(904) 997-1121
FL	3232	Traenkner, Richard C.	8687 W. Hwy 192	Kissimmee	34747	(407) 238-2266
FL	3233	Blalock, William D. III	1540 N. Singleton Avenue	Titusville	32796	(321) 268-3535
FL	3236	Ceide, Richard T.	1024 N. Avalon Park Boulevard	Orlando	32828	(407) 601-3996
FL	3237	Farace, Alvaro C.	15275 Collier Boulevard #208	Naples	34119	(239) 304-3040
FL	3242	Machin, Robert	605 W. Madison Street	Starke	32091	(904) 964-5442
FL	3243	May, Roy Jeffrey	394 South Hwy 29	Cantonment	32533	(850) 968-1233
FL	3246	Longen, Jerry A.	4620 NW 39th Avenue, Suite C	Gainesville	32606	(352) 692-2222
FL	3247	Havener, Jonathan A.	6750 N. Orange Blossom Trail, Suite B-6	Orlando	32810	(407) 515-3030
FL	3251	Zebib, Mohammad A.	123 Cashmere Boulevard	Port Saint Lucie	34986	(772) 878-1530
FL	3252	Longen, Jerry A.	1534 Bloomingdale Avenue	Valrico	33596	(813) 685-8012
FL	3254	Machin, Robert	1112 State Road 20	Interlachen	32148	(386) 684-4400
FL	3256	Machin, Robert	7403 State Road 21	Keystone Heights	32656	(352) 473-7070
FL	3257	Villas Boas, Marcio R.	3253 S. John Young Parkway	Kissimmee	34746	(407) 809-0400
FL	3258	Welker, William L.	11224 Boyette Road	Riverview	33569	(813) 234-0800
FL	3259	Traenkner, Richard C.	3378 W. Southport Road	Kissimmee	34746	(407) 870-2200
FL	3260	Longen, Jerry A.	14300 W. Newberry Road	Newberry	32669	(352) 333-3333
FL	3263	Traenkner, Richard C.	3171 W. Vine Street	Kissimmee	34741	(407) 343-4633
FL	3264	Wileman, Robert W.	7813 Mitchell Boulevard, Trinity Commons, Unit 5	New Port Richey	34655	(727) 816-9898
FL	3266	Welker, William L.	1200 Havendale Boulevard	Winter Haven	33881	(863) 488-9990
FL	3267	Welker, William L.	45717 US Highway 27 North	Davenport	33897	(863) 424-5222
FL	3268	Ceide, Richard T.	1822 S. Ridgewood Avenue	Edgewater	32141	(386) 428-2625
FL	3270	Drury, Nancy	1609 Andulusia Boulevard	Cape Coral	33909	(239) 458-9905
FL	3271	Walker, Michael W.	356 Shopping Center Drive	Wildwood	34785	(352) 330-0303
FL	3272	Carter, Tracy V.	9590 SW Highway 200	Ocala	34481	(352) 369-5050
FL	3291	Longen, Jerry A.	2488 N. Heritage Oaks Path	Hernando	34442	(352) 527-1240
FL	3293	Longen, Jerry A.	2605 E. Gulf Lake Highway, Unit 2C	Inverness	34453	(352) 423-4145
FL	3800	Lewis, Thomas R.	1301 Monument Road, Suite 25	Jacksonville	32225	(904) 724-7206
FL	3802	Pichardo, Franklin L.	405 Racetrack Road, Suite 102	Ft. Walton Beach	32547	(850) 862-1151

Exhibit B Traditional
as of December 31, 2023

FL	3803	Jandrew, Brian K.	10114 S. Military Trail, Suite 109	Boynton Beach	33436	(561) 736-5333
FL	3805	Diaz, Nelson	860A US Highway 17-92	Longwood	32750	(407) 331-1881
FL	3808	Welker, William L.	365 8th Street South	St. Petersburg	33701	(727) 896-3030
FL	3809	Jandrew, Brian K.	1336 S. Military Trail	West Palm Beach	33415	(561) 969-3030
FL	3810	Zebib, Mohammad A.	3311 SE Federal Highway	Stuart	34997	(772) 221-9915
FL	3813	Welker, William L.	14955 N. Florida Avenue	Tampa	33613	(813) 964-0441
FL	3814	Longen, Jerry A.	13081 Spring Hill Drive	Spring Hill	34609	(352) 686-2100
FL	3815	Farace, Alvaro C.	7385 Radio Road #102	Naples	34104	(239) 354-2444
FL	3816	Farace, Alvaro C.	3890 Sw 112th Avenue	Miami	33165	(239) 719-1819
FL	3817	Cardenas, Lester Daniel	91200 Overseas Highway, Suite 7	Tavernier	33070	(305) 853-2525
FL	3819	Welker, William L.	2659 Ulmerton Road	Cleawater	33762	(727) 572-0700
FL	3820	Farace, Alvaro C.	4800 Bayline Drive	North Fort Myers	33917	(239) 995-1100
FL	3821	Traenkner, Richard C.	8578 Palm Parkway	Orlando	32836	(407) 239-1221
FL	3823	Zdanowicz, Paul J.	2150-A Tamiami Trail	Port Charlotte	33948	(941) 624-3737
FL	3824	Salemo, Thomas	700 E. Colonial Drive	Orlando	32803	(407) 813-1400
FL	3825	Zdanowicz, Paul J.	104 Rio Villa Drive	Punta Gorda	33950	(941) 637-8887
FL	3826	Vivas, Gaston	8539 South Tamiami Trail	Sarasota	34238	(941) 924-1001
FL	3827	Diaz, Nelson	3840 E. SR 436, Suite 1048	Apopka	32714	(407) 789-2500
FL	3830	Soto, Christa E.	171 S State Road 7	Royal Palm Beach	33414	(561) 729-0015
FL	3831	Dahn, Tyler H.	15508 West Colonial Drive, Unit 103	Orlando	34787	(407) 993-6766
FL	3832	Soto, Christa E.	12769-B West Forest Hill Boulevard	Wellington	33414	(561) 798-6744
FL	3833	Traenkner, Richard C.	4976 Millenia Boulevard, Suite A	Orlando	32839	(407) 815-8877
FL	3834	Ceide, Richard T.	10057 University Boulevard	Orlando	32817	(407) 384-8888
FL	3835	Traenkner, Richard C.	2104 Whisper Lakes Boulevard	Orlando	32837	(407) 851-8884
FL	3836	Jandrew, Brian K.	1201 US Highway 1, Suite 8	N Palm Beach	33408	(561) 694-3030
FL	3837	Longen, Jerry A.	1651 Highway 331	Defuniak Springs	32433	(850) 347-2444
FL	3838	Reulbach, Anthony S.	17855 US Highway 441	Mount Dora	32757	(352) 383-1010
FL	3840	Diaz, Nelson	1795 E. Broadway Street	Oviedo	32765	(407) 971-9663
FL	3841	Longen, Jerry A.	17804 N. Dale Mabry Highway	Lutz	33548	(813) 960-1888
FL	3843	Proctor, Keith	236 Solano Road	Ponte Vedra	32082	(904) 285-1220
FL	3845	Mullins, Erin M.	909 1st Street E	Bradenton	34208	(941) 747-7879
FL	3848	Longen, Jerry A.	14351 US Hwy 301 S#8	Wimauma	33598	(813) 530-5050
FL	3849	Longen, Jerry A.	2615 Crawfordville Highway	Crawfordville	32327	(850) 738-5100
FL	3850	Spero, Charles	4761 N. Tamiami Trail N	Naples	34103	(239) 430-3930
FL	3852	Farace, Alvaro C.	26455 Old US 41 Road, Suite #2	Bonita Springs	34135	(239) 992-9400
FL	3854	DeGood, Douglas A.	2439 Thomas Drive, Unit 900	Panama City Beach	32408	(850) 249-3001
FL	3856	DeGood, Douglas A.	715 Ohio Avenue	Lynn Haven	32444	(850) 265-0606

Exhibit B Traditional
as of December 31, 2023

FL	3857	Reulbach, Anthony S.	1675 Providence Boulevard, Suite B	Deltona	32725	(386) 218-3852
FL	3859	Welker, William L.	5622 Cypress Gardens Boulevard	Winter Haven	33884	(863) 324-5636
FL	3860	DeGood, Douglas A.	9528 Front Beach Road	Panama City Beach	32407	(850) 234-3030
FL	3861	Cole, David Allen	4150 Nw 7th Street	Miami	33126	(863) 448-4598
FL	3863	Sheikh, Ahsan M.	12200-22 San Jose Boulevard	Jacksonville	32223	(904) 260-0030
FL	3864	Diaz, Nelson	7125 Hoffner Avenue, Suite 105	Orlando	32822	(407) 237-0393
FL	3865	DeGood, Douglas A.	272 S. Arnold Road (aka Highway 79)	Panama City Beach	32413	(850) 235-3030
FL	3866	Zebib, Mohammad A.	300 Port Street Lucie Boulevard	Port St. Lucie	34984	(772) 879-0083
FL	3867	Longen, Jerry A.	1691 Main Street, Unit 1	Chipley	32428	(850) 750-2121
FL	3868	Magnes, Scott J.	372 Gulf Breeze Parkway	Gulf Breeze	32561	(850) 565-3050
FL	3869	Vivas, Gaston	7021 Constitution Boulevard	Ft. Myers	33912	(239) 267-1200
FL	3870	Sherrick, Keith W.	240 Citrus Tower Boulevard, Suite H	Clermont	34711	(352) 242-1277
FL	3872	Welker, William L.	104 Commonwealth Avenue, Ste 2	Polk City	33868	(863) 874-4888
FL	3873	Endicott, Chasity Kaye	130 Scenic Golf Drive, Suite 4a	Miramar Beach	32550	(850) 424-7759
FL	3874	Walker, Michael W.	1864 S. Jefferson Street	Perry	32348	(850) 584-8830
FL	3875	Vivas, Gaston	13125 S. Tamiami Trail	North Port	34287	(941) 426-9591
FL	3876	Traenkner, Richard C.	5461 W. Highway 192	Kissimmee	32741	(407) 396-0550
FL	3877	Zebib, Mohammad A.	1675 NW Street Lucie West Boulevard	Port St. Lucie	34986	(722) 210-9090
FL	3878	Sheikh, Ahsan M.	9680 Argyle Forest Boulevard, Suite 26	Jacksonville	32222	(904) 513-3993
FL	3879	Jandrew, Brian K.	4388 Northlake Boulevard	Palm Beach Gardens	33410	(561) 694-3077
FL	3880	Moghadam, Jahanfar N.	5891 S. Military Trail, Unit 2	Lake Worth	33463	(561) 641-3030
FL	3881	Diaz, Nelson	3801 W. Lake Mary Boulevard #107	Lake Mary	32746	(407) 322-9060
FL	3882	Pichardo, Franklin L.	34920 Emerald Coast Parkway	Destin	32541	(850) 837-0303
FL	3883	Farace, Alvaro C.	1127 Homestead Road	Lehigh Acres	33936	(239) 368-7600
FL	3884	Drury, Nancy	3904 Skyline Boulevard	Cape Coral	33914	(239) 945-0040
FL	3885	Welker, William L.	32530 US Highway 19 N	Palm Harbor	34684	(727) 789-3030
FL	3886	Longen, Jerry A.	8381 Northcliffe Boulevard	Spring Hill	34606	(352) 684-0005
FL	3888	Zdanowicz, Paul J.	3502 N. Access Road	Englewood	34224	(941) 475-5691
FL	3890	Vivas, Gaston	732 Shamrock Boulevard	Venice	34293	(941) 497-5050
FL	3891	Dawson, William	3416 N. Ocean Boulevard	Ft. Lauderdale	33308	(954) 565-3030
FL	3893	Longen, Jerry A.	213 E. Highland Boulevard	Inverness	34452	(352) 637-5300
FL	3894	Sheikh, Ahsan M.	8029-2 Ramona Boulevard	Jacksonville	32221	(904) 781-1101
FL	3897	Traenkner, Richard C.	8957 International Drive #201	Orlando	32819	(407) 352-5522
FL	4900	Smith, Eric S.	5611 Woodbine Road	Pace	32571	(850) 738-5656
FL	4901	Sheikh, Ahsan M.	1210 Blanding Boulevard	Orange Park	32065	(904) 276-9000
FL	4902	Sheikh, Ahsan M.	2085 A1A South #106	St. Augustine	32080	(904) 461-3030
FL	4903	Zebib, Mohammad A.	1119 NE Jensen Beach Boulevard	Jensen Beach	34957	(772) 208-5516

Exhibit B Traditional
as of December 31, 2023

FL	4905	Smith, Eric S.	6551 Caroline Street	Milton	32570	(850) 626-0003
FL	4906	Price, Richard W.	5325 N Wickham Road, Suite 103	Melbourne	32940	(321) 294-4949
FL	4907	Longen, Jerry A.	5811 Memorial Highway, Suite #101	Tampa	33615	(813) 882-0023
FL	4908	Sheikh, Ahsan M.	9 W. 45th Street	Jacksonville	32208	(904) 353-4744
FL	4909	Nazari, Hassan	6295 Minton Road NE, Unit 3	Palm Bay	32907	(321) 723-7222
FL	4911	Guaita, Jose L.	1424 Drive Martin Luther King Way	Sarasota	34234	(941) 529-0777
FL	4912	Longen, Jerry A.	1702-C 50th Street	Tampa	33619	(813) 678-2300
FL	4913	Lewis, Thomas R.	13947 Beach Boulevard	Jacksonville	32224	(904) 821-8000
FL	4914	Longen, Jerry A.	1519 Capital Circle NE, Suite 27	Tallahassee	32308	(850) 656-3030
FL	4915	Welker, William L.	7372 Kathleen Road	Lakeland	33810	(863) 345-1500
FL	4916	Welker, William L.	5315 N. US Highway 98	Lakeland	33809	(863) 858-2251
FL	4917	Brooks, Steven P.	1105 N. Nova Road	Holly Hill	32117	(386) 253-3151
FL	4918	Ramia, Jose Y.	15990 E. Highway 40	Orlando	34488	(352) 758-2900
FL	4920	Jandrew, Brian K.	8038 Wiles Road	Coral Springs	33067	(954) 341-0600
FL	4922	Diaz, Nelson	2042 North Forsyth Road, Suite E	Winter Park	32807	(407) 677-8686
FL	4923	Ramia, Jose Y.	3131 SW College Road #305	Ocala	34474	(352) 867-5900
FL	4924	Martinez, Carlos H.	2201 West Sample Road, Bldg. A	Pompano Beach	33073	(954) 974-3399
FL	4925	Zebib, Tarick	5445 20th Street #103	Vero Beach	32966	(772) 794-4561
FL	4926	Zebib, Tarick	971 Sebastian Boulevard, Suite 8	Sebastian	32958	(772) 388-3030
FL	4928	Ceide, Richard T.	1844 Renuilli Road	New Smyrna Beach	32168	(386) 428-2021
FL	4929	Welker, William L.	7064 US Highway 19 North	Pinellas Park	33781	(727) 217-5530
FL	4930	Price, Richard W.	5360 N. Atlantic Avenue	Cocoa Beach	32931	(321) 783-0266
FL	4932	Wackerbarth, Matthew	11582 N. Williams Street, Suite 505	Dunnellon	34432	(352) 251-3030
FL	4933	Zebib, Tarick	5220 US Highway 1, Suite 102	Vero Beach	32967	(772) 242-9988
FL	4934	Soto, Christa E.	503 E. Sugarland Highway	Clewiston	33440	(863) 983-4131
FL	4935	Longen, Jerry A.	8730 State Road 52	Hudson	34667	(727) 863-2026
FL	4936	Price, Richard W.	923 N. Courtenay Parkway, Suite 103	Merritt Island	32953	(321) 452-9195
FL	4937	Zebib, Mohammad A.	6382 S. Federal Highway	Stuart	34997	(772) 286-3030
FL	4938	Wackerbarth, Matthew	366 N. Suncoast Boulevard	Crystal River	34429	(352) 563-6607
FL	4940	Price, Richard W.	4600 W. King Street	Cocoa	32926	(321) 294-4646
FL	4941	Sheikh, Ahsan M.	101 W Matanzas Woods Parkway	Palm Coast	32137	(386) 597-0330
FL	4942	Longen, Jerry A.	5031 US Highway 19	New Port Richey	34652	(772) 777-5055
FL	4943	Ramia, Jose Y.	5830 SE Abshire Boulevard	Bellevue	34420	(352) 307-8885
FL	4944	Longen, Jerry A.	1800 NE 12th Avenue	Gainesville	32641	(386) 603-4700
FL	4945	Farace, Alvaro C.	13008 Palm Beach Boulevard	Fort Myers	33905	(239) 693-7600
FL	4946	Farace, Alvaro C.	4770 Colonial Boulevard	Ft. Myers	33966	(239) 990-5656
FL	4947	De Guia, Cheri F.	4080 Cattleman Road	Sarasota	34233	(941) 378-0030

Exhibit B Traditional
as of December 31, 2023

FL	4948	Brooks, Steven P.	2678 LPGA Boulevard	Daytona Beach	32124	(386) 256-7696
FL	4949	Vivas, Gaston	7610 Lockwood Ridge Road	Sarasota	34243	(941) 359-3033
FL	4957	Nazari, Hassan	3555 Bayside Lake Boulevard SE, Unit #6	Palm Bay	32909	(321) 676-9992
FL	4997	Reulbach, Anthony S.	1936 N Highway 19	Eustis	32726	(352) 483-4688
FL	5000	Longen, Jerry A.	320 E Cass Street	Tampa	33602	(813) 221-1611
FL	5001	Longen, Jerry A.	2316 E. Fletcher Avenue	Tampa	33612	(813) 971-7875
FL	5002	Longen, Jerry A.	5480 E. Busch Boulevard	Temple Terrace	33617	(813) 988-9145
FL	5003	Longen, Jerry A.	5801 N. Florida Avenue	Tampa	33604	(813) 238-9557
FL	5004	Longen, Jerry A.	3801 W. Gandy Boulevard	Tampa	33611	(813) 837-0591
FL	5005	Longen, Jerry A.	8206 West Waters Avenue	Tampa	33615	(813) 885-5481
FL	5007	Longen, Jerry A.	4115 W. Kennedy Boulevard	Tampa	33609	(813) 875-3664
FL	5008	Welker, William L.	11406 North Dale Mabry Highway	Tampa	33618	(813) 963-3030
FL	5009	Longen, Jerry A.	7104 East Fowler Avenue	Tampa	33617	(813) 736-1200
FL	5010	Mullins, Erin M.	7353 University Parkway	Lakewood Ranch	34202	(941) 526-0313
FL	5011	Longen, Jerry A.	1903 W. Brandon Boulevard	Brandon	33511	(813) 681-4330
FL	5012	Dahn, Tyler H.	10821 W. Colonial Drive	Ocoee	34761	(407) 656-3053
FL	5013	Diaz, Nelson	2 E. Main Street	Apopka	32703	(407) 886-0744
FL	5014	Traenkner, Richard C.	13384 Hartzog Road	Winter Garden	34787	(407) 337-3030
FL	5015	Traenkner, Richard C.	4235 13th Street	St. Cloud	34769	(407) 957-2200
FL	5016	Zdanowicz, Paul J.	1700 South Parrot Avenue, Suite B	Okeechobee	34974	(863) 763-5565
FL	5017	Vivas, Gaston	1022 8th Avenue W.	Palmetto	34221	(941) 723-3030
FL	5018	Longen, Jerry A.	40188 US Highway 19 N.	Tarpon Springs	34689	(727) 945-1700
FL	5019	Welker, William L.	6191 66th Street N.	Pinellas Park	33781	(727) 541-7793
FL	5020	Welker, William L.	2245 Nursery Road	Clearwater	33764	(727) 536-5981
FL	5021	Longen, Jerry A.	23698 US Highway 19 N.	Clearwater	33765	(727) 791-3030
FL	5022	Welker, William L.	5830 9th Avenue North	St. Petersburg	33710	(727) 323-1202
FL	5023	Welker, William L.	11125 Park Boulevard	Seminole	33772	(727) 391-9901
FL	5024	McDermott, Elizabeth A.	1410 Pinehurst Road	Dunedin	34698	(727) 736-3030
FL	5025	Welker, William L.	6511 4th Street N.	St. Petersburg	33703	(727) 522-3030
FL	5026	Welker, William L.	423 S. Myrtle Avenue	Clearwater	33756	(727) 442-3030
FL	5027	Welker, William L.	12613 Ulmerton Road	Largo	33774	(727) 581-3030
FL	5028	Welker, William L.	800 E. Bay Drive, Suite D	Largo	33770	(727) 551-4600
FL	5029	Zdanowicz, Paul J.	1940-1 Kings Highway	Port Charlotte	33980	(941) 624-3030
FL	5030	Welker, William L.	1523 Bartow Road	Lakeland	33801	(863) 688-5226
FL	5031	Welker, William L.	204 W. Alexander Street	Plant City	33563	(813) 759-9424
FL	5032	Longen, Jerry A.	6488 Ridge Road	Port Richey	34668	(727) 847-5182
FL	5033	Longen, Jerry A.	3800 Tampa Road, #180	Oldsmar	34677	(813) 855-3030

Exhibit B Traditional
as of December 31, 2023

FL	5034	Longen, Jerry A.	1356 Commercial Way	Spring Hill	34606	(352) 403-0008
FL	5035	Wackerbarth, Matthew	7305 Broad Street	Brooksville	34601	(352) 796-8888
FL	5036	Zdanowicz, Paul J.	313 US Highway 27 N	Sebring	33870	(863) 471-3030
FL	5037	Zdanowicz, Paul J.	1093 W. Main Street	Avon Park	33825	(863) 452-5116
FL	5038	Mullins, Erin M.	4507 Manatee Avenue W.	Bradenton	34209	(941) 748-3030
FL	5039	Mullins, Erin M.	1403 57th Avenue W.	Bradenton	34207	(941) 758-3030
FL	5040	Vivas, Gaston	1100 N. Tuttle Avenue, Space No. 9	Sarasota	34237	(941) 365-4900
FL	5041	Vivas, Gaston	3692 Webber Street	Sarasota	34232	(941) 923-3831
FL	5043	Farace, Alvaro C.	5494 Rattlesnake Hammock Road	Naples	34113	(239) 417-3030
FL	5044	Drury, Nancy	4409 Del Prado Boulevard	Cape Coral	33904	(239) 549-5500
FL	5045	Vivas, Gaston	3112 Cleveland Avenue	Ft. Myers	33901	(239) 334-3800
FL	5046	Vivas, Gaston	6631 Orion Drive #109	Ft Myers	33912	(239) 936-4020
FL	5047	Farace, Alvaro C.	4550 Palm Beach Boulevard	Fort Myers	33905	(239) 693-1600
FL	5048	Diaz, Nelson	532 W. State Route 436	Allamonte Springs	32714	(407) 682-2737
FL	5049	Traenkner, Richard C.	5944 S. Orange Blossom Trail	Orlando	32809	(407) 850-2222
FL	5050	Havener, Jonathan A.	6101 Silver Star Road	Orlando	32808	(407) 291-6676
FL	5051	Diaz, Nelson	2510 S. Semoran Boulevard	Orlando	32822	(407) 384-8877
FL	5052	Jandrew, Brian K.	2800 N. Military Trail, Unit 101	West Palm Beach	33409	(561) 686-3332
FL	5053	Havener, Jonathan A.	1510 S. Orlando Avenue	Maitland	32751	(407) 628-2623
FL	5054	Jandrew, Brian K.	8918 C/D Lantana Road	Lake Worth	33467	(561) 609-2222
FL	5055	Blalock, William D. III	1850 Knox McRae Drive #102	Titusville	32780	(321) 268-8008
FL	5056	Reulbach, Anthony S.	1670 W. Airport Boulevard	Sanford	32771	(407) 321-5000
FL	5057	Zebib, Tarick	755 8th Street	Vero Beach	32962	(772) 778-3030
FL	5058	Jandrew, Brian K.	6548 Lake Worth Boulevard	Lake Worth	33467	(561) 433-1122
FL	5059	Soto, Christa E.	1760 N. Jog Road, Unit 130	West Palm Beach	33411	(561) 318-5023
FL	5060	Mullins, Erin M.	4874 Cortez Road West	Bradenton	34210	(941) 526-0414
FL	5061	Price, Richard W.	2480 Aurora Road	Melbourne	32935	(321) 242-2202
FL	5062	Jandrew, Brian K.	450 North Lake Boulevard, #2	N. Palm Beach	33408	(561) 845-7700
FL	5063	Longen, Jerry A.	24950 W Newberry Road	Newberry	32669	(352) 660-0606
FL	5064	Corcoran, Neal T.	3380 W. Hillsboro Boulevard	Deerfield Beach	33442	(954) 429-3030
FL	5065	Jandrew, Brian K.	21073 Powerline Road, Suite 39	Boca Raton	33433	(561) 483-8331
FL	5066	Traenkner, Richard C.	10039 Orange Avenue, Suite B	Orlando	32824	(407) 990-1050
FL	5068	Proctor, Keith	185 Murabella Parkway, Unit 3	St. Augustine	32092	(904) 593-5068
FL	5069	Traenkner, Richard C.	1918 E. Osceola Parkway	Kissimmee	34743	(407) 348-4100
FL	5071	Jandrew, Brian K.	1328 N.W. 2nd Avenue	Boca Raton	33431	(561) 391-9177
FL	5072	Traenkner, Richard C.	13458 Landstar Boulevard, Unit 104	Orlando	32824	(407) 698-4100
FL	5073	Jandrew, Brian K.	3401 North Federal Highway	Pompano Beach	33064	(954) 953-0080

Exhibit B Traditional
as of December 31, 2023

FL	5074	Jandrew, Brian K.	10101 Glades Road	Boca Raton	33498	(561) 487-1377
FL	5076	Jandrew, Brian K.	142 SE 6th Avenue, Suites G & H	Delray Beach	33483	(561) 330-0002
FL	5077	Reulbach, Anthony S.	2135 Howland Boulevard	Deltona	32738	(386) 866-9191
FL	5078	Martinez, Carlos H.	5452 N. University Drive	Lauderhill	33351	(954) 748-7707
FL	5080	Dawson, William	400 E. Oakland Park Boulevard	Oakland Park	33334	(954) 564-7312
FL	5083	Brinkley, Sean A.	18173 Biscayne Boulevard	Aventura	33160	(786) 648-5400
FL	5085	Farace, Alvaro C.	870 W. Hickpochee Avenue, Unit 1700	Labelle	33935	(863) 302-9332
FL	5087	Corcoran, Neal T.	210 N. Federal Highway	Deerfield Beach	33441	(954) 574-9994
FL	5089	Nazari, Hassan	1040 Malabar Road SE	Palm Bay	32907	(321) 220-0045
FL	5091	Longen, Jerry A.	143 West Noble Avenue, Unit B	Williston	32696	(352) 496-4600
FL	5092	Ranson, Murphy D. III	2704 N. Roosevelt Boulevard	Key West	33040	(305) 296-7795
FL	5093	Farace, Alvaro C.	5963 Pine Ridge Road	Naples	34119	(239) 350-1500
FL	5095	Longen, Jerry A.	2215 Ohio Avenue #3	Live Oak	32064	(386) 287-5600
FL	5100	Sheikh, Ahsan M.	6003-6 Roosevelt Boulevard	Jacksonville	32244	(904) 778-4295
FL	5101	Lewis, Thomas R.	2440 Mayport Road #1	Atlantic Beach	32233	(904) 241-7231
FL	5102	Machin, Robert	6651 Arlington Road	Jacksonville	32211	(904) 743-7220
FL	5103	Sheikh, Ahsan M.	870 Cassat Avenue	Jacksonville	32205	(904) 781-6420
FL	5104	Sheikh, Ahsan M.	1580 Wells Road, Suite #3	Orange Park	32073	(904) 269-4090
FL	5105	Sheikh, Ahsan M.	3570 US Highway 1 South	St. Augustine	32806	(904) 794-4655
FL	5106	Proctor, Keith	630 N. 3rd Street	Jacksonville Beach	32250	(904) 247-1556
FL	5107	Sheikh, Ahsan M.	418 Starratt Road, Suite 2	Jacksonville	32218	(904) 757-0303
FL	5108	Sheikh, Ahsan M.	10031 San Jose Boulevard	Jacksonville	32257	(904) 268-5069
FL	5109	Machin, Robert	9802-1 Bay Meadows Road	Jacksonville	32216	(904) 642-5190
FL	5110	Zdanowicz, Paul J.	1560 Price Creek Way	North Port	34288	(941) 200-5443
FL	5111	Sheikh, Ahsan M.	8204 103rd Street	Jacksonville	32210	(904) 778-3030
FL	5112	Sheikh, Ahsan M.	1124 S. 14th Street	Fernandina Beach	32034	(904) 277-2200
FL	5113	Machin, Robert	7020 Beach Boulevard	Jacksonville	32216	(904) 724-8046
FL	5115	DePalma, Joseph T.	7578 S.E. Maricamp Road	Ocala	34472	(352) 261-1000
FL	5116	Longen, Jerry A.	4375 Lafayette Street	Marianna	32446	(850) 482-3333
FL	5117	Longen, Jerry A.	11133 County Line Road, Unit 101/103	Spring Hill	34609	(352) 469-1800
FL	5119	Vivas, Gaston	8595 College Parkway, Suite 1A	Fl. Myers	33919	(239) 433-4000
FL	5120	Welker, William L.	4925 34th Street South	St Petersburg	33711	(727) 866-8691
FL	5121	Traenkner, Richard C.	5389 S. Kirkman Road	Orlando	32819	(407) 248-8434
FL	5122	Price, Richard W.	500 Barton Boulevard	Rockledge	32955	(321) 639-0880
FL	5123	Carter, Tracy V.	261 Marion Oaks Boulevard	Ocala	34473	(352) 269-5000
FL	5124	Zabib, Mohammad A.	10642 U.S. Highway 1	Port St Lucie	34952	(772) 335-0333
FL	5125	Mullins, Erin M.	5606 Marina Drive	Holmes Beach	34217	(941) 778-6641

Exhibit B Traditional
as of December 31, 2023

FL	5126	Zebib, Mohammad A.	706 SE Becker Road	Port St. Lucie	34984	(772) 800-6464
FL	5127	Diaz, Nelson	3800 E. Colonial Drive	Orlando	32803	(407) 757-2700
FL	5128	Salemo, Thomas	2823 S. Orange Avenue, Suite 110	Orlando	32806	(407) 896-3030
FL	5129	Longen, Jerry A.	2915 Kerry Forest Parkway, Suite 602	Tallahassee	32309	(850) 893-0186
FL	5130	Tran, Dennis V.	3507 N. Monroe Street, Suite C	Tallahassee	32303	(850) 562-2523
FL	5131	Tran, Dennis V.	1528 W. Tennessee Street	Tallahassee	32304	(850) 222-6363
FL	5132	Tran, Dennis V.	2320 Apalachee Parkway	Tallahassee	32301	(850) 878-6146
FL	5133	Sheikh, Ahsan M.	12100 Lem Turner Road	Tallahassee	32218	(904) 768-4434
FL	5134	Reulbach, Anthony S.	1699 N Woodland Boulevard	Deland	32720	(386) 866-5200
FL	5135	Briggs, Robert A.	100 North Main Street	Hastings	32145	(904) 692-1188
FL	5136	Price, Richard W.	18 E. Lincoln Street	Melbourne	32901	(321) 768-1445
FL	5137	Traenkner, Richard C.	11620 Lakeside Village Lane, Suite 120	Windermere	34786	(407) 612-7877
FL	5138	Zebib, Mohammad A.	990 SW Martin Downs Boulevard	Palm City	34990	(772) 286-4848
FL	5139	Brooks, Steven P.	343 W. Granada Boulevard	Ormond Beach	32174	(386) 677-3030
FL	5140	Ramia, Jose Y.	211 North Atlantic Avenue	Daytona Beach	32118	(386) 257-1884
FL	5141	Reulbach, Anthony S.	209 N. Amelia Avenue	Deland	32724	(386) 738-1500
FL	5142	Ceide, Richard T.	1563 S. Nova Road	Daytona Beach	32114	(386) 756-4440
FL	5143	Salemo, Thomas	6401 Raleigh Street	Orlando	32835	(321) 430-0101
FL	5144	Ceide, Richard T.	1820 Dunlawton Avenue, Unit 101	Port Orange	32127	(386) 756-2104
FL	5145	Rice, Derek Robert	246 Highway A1A	Satellite Beach	32937	(321) 777-4433
FL	5146	Jandrew, Brian K.	1446 N State Road 7	Margate	33063	(954) 974-3030
FL	5147	Welker, William L.	2029 State Road 60 East	Lake Wales	33898	(863) 679-9999
FL	5148	Drury, Nancy	1133 Del Prado Boulevard S.	Cape Coral	33990	(239) 772-5060
FL	5149	Ramia, Jose Y.	2009 Citrus Boulevard	Leesburg	34748	(352) 787-2600
FL	5150	Longen, Jerry A.	2106 SW 13th Street	Gainesville	32608	(352) 373-2337
FL	5151	Longen, Jerry A.	15634 NW Highway 441, Suite A	Alachua	32615	(386) 462-2000
FL	5152	Ceide, Richard T.	588 S Alafaya Trail, Unit 50	Orlando	32828	(407) 604-0808
FL	5153	Drury, Nancy	1506 Chiquita Boulevard S.	Cape Coral	33991	(239) 458-8000
FL	5154	Nazari, Hassan	4700 Babcock Street NE, Suite #4	Palm Bay	32905	(321) 984-1712
FL	5155	Walker, Michael W.	3855 E. Silver Springs Boulevard #101	Ocala	34470	(352) 368-6868
FL	5156	Machin, Robert	1602 Reid Street	Palatka	32177	(386) 325-0112
FL	5157	Reulbach, Anthony S.	3653 S Orlando Drive	Sanford	32773	(407) 789-2400
FL	5158	Reulbach, Anthony S.	4720 W. State Road 46, Suite 1210	Sanford	32771	(407) 906-1800
FL	5159	May, Roy Jeffrey	1001 E. Nine Mile Road	Pensacola	32514	(850) 478-3030
FL	5160	May, Roy Jeffrey	31 N. Navy Boulevard	Pensacola	32507	(850) 453-1221
FL	5161	Pichardo, Franklin L.	437 John Sims Parkway	Valparaiso	32580	(850) 678-1161
FL	5162	May, Roy Jeffrey	6704 N. 9th Avenue	Pensacola	32504	(850) 478-5056

Exhibit B Traditional
as of December 31, 2023

FL	5163	May, Roy Jeffrey	3014 W. Michigan Avenue	Pensacola	32526	(850) 944-5619
FL	5164	DeGood, Douglas A.	1111 W 15th Street	Panama City	32401	(850) 784-3030
FL	5165	DeGood, Douglas A.	519 N. Tyndall Parkway	Panama City	32404	(850) 763-5906
FL	5166	Pichardo, Franklin L.	656 N Beal Parkway, Unit F&G	Fl. Walton Beach	32548	(850) 863-4154
FL	5167	May, Roy Jeffrey	3310 N. Pace Boulevard, Unit A	Pensacola	32505	(850) 435-9700
FL	5168	Portuhondo, James	2729 S. US Highway 1	Ft. Pierce	34982	(772) 464-3006
FL	5169	Jandrew, Brian K.	836 Lantana Road	Lantana	33462	(561) 533-0905
FL	5172	Jandrew, Brian K.	7118 Southgate Boulevard, Ste 6	North Lauderdale	33068	(954) 953-0090
FL	5174	Soto, Christa E.	5420 Donald Ross Road, Unit C1-115	Palm Beach Gardens	33418	(561) 570-5099
FL	5175	Soto, Christa E.	10200 Fox Trail Road South, Suite D	Royal Palm Beach	33411	(561) 793-1166
FL	5176	Bader, Issa A.	12225 SW 112th Street	Miami	33186	(305) 274-1232
FL	5177	Bader, Issa A.	8737 Coral Way	Miami	33165	(305) 227-0551
FL	5178	Jandrew, Brian K.	1672 S. Congress Avenue	Palm Springs	33461	(561) 965-3030
FL	5181	Sheikh, Ahsan M.	12529 Yellow Bluff Road, Suite 7	Jacksonville	32226	(904) 738-7050
FL	5182	Sheikh, Ahsan M.	11930 Sw 8th Street	Miami	33184	(904) 217-3382
FL	5184	Aguilera, Francisco Benito	11045 SW 216th Street	Miami	33170	(786) 505-1800
FL	5185	Jandrew, Brian K.	4801 Linton Boulevard, Bay A-02	Delray Beach	33445	(561) 496-3030
FL	5188	Jandrew, Brian K.	11339 W Atlantic Boulevard	Coral Springs	33071	(954) 344-0991
FL	5190	Cardenas, Lester Daniel	99620 Overseas Highway	Key Largo	33037	(305) 451-2939
FL	5192	Soto, Christa E.	2562 W. Indiantown Road #2	Jupiter	33458	(561) 744-6171
FL	5195	Welker, William L.	36801 State Road 52	Dade City	33525	(352) 523-1099
FL	5198	Sheikh, Ahsan M.	463155 SR - 200 #11	Yulee	32097	(904) 468-5955
FL	8602	Dawson, William	912 N. Federal Highway	Fort Lauderdale	33304	(754) 247-9000
FL	8603	Longen, Jerry A.	715 N Main Street	Trenton	32693	(352) 658-5600
FL	8604	Pichardo, Franklin L.	4563 E. Highway 20	Niceville	32578	(850) 897-3366
FL	8608	Brinkley, Sean A.	17028 Collins Avenue	Sunny Isles Beach	33160	(305) 947-6900
FL	8609	Sheikh, Ahsan M.	1967 Old Moultrie Road	St. Augustine	32086	(904) 814-8977
FL	8610	Sherrick, Keith W.	457 S. Duncan Drive (SR 19)	Tavares	32778	(352) 742-9866
FL	8612	Sherrick, Keith W.	1200 West Broad Street, Suite A	Groveland	34736	(352) 429-4500
FL	8614	Soto, Christa E.	7070-01 Seminole Pratt Whitney	Loxahatchee	34970	(561) 333-1415
FL	8615	Longen, Jerry A.	13235 State Rd 52, Suite 105	Hudson	34669	(727) 848-3030
FL	8618	DeGood, Douglas A.	6547 Highway 231	Panama City	32404	(850) 772-1990
FL	8619	Mullins, Erin M.	2551 Lakewood Ranch Boulevard, Suite 108	Bradenton	34211	(941) 748-1234
FL	8620	Diaz, Nelson	4250 W. Plaza Drive	Orlando	32816	(407) 882-0022
FL	8622	Traenkner, Richard C.	15505 Stonybrook West Parkway #110	Winter Garden	34787	(407) 656-6000
FL	8626	Farace, Alvaro C.	10654 Colonial Boulevard, Suite #1	Ft. Myers	33913	(239) 768-3131
FL	8627	Mullins, Erin M.	8163 US Highway 301 N.	Parrish	34219	(941) 479-7911

Exhibit B Traditional
as of December 31, 2023

FL	8629	Welker, William L.		9306 Narcoossee Road	Lake Nona	32827	(407) 286-2922
FL	8630	Welker, William L.		7229 N. Dale Mabry Highway	Tampa	33614	(813) 964-6864
FL	8632	Welker, William L.		947 E. Brandon Boulevard	Brandon	33511	(813) 438-5991
FL	8633	Welker, William L.		8576 Gunn Highway	Odessa	33556	(813) 510-3970
FL	8634	Traenkner, Richard C.		3003 Edgewater Drive	Orlando	32804	(407) 270-8840
FL	8636	May, Roy Jeffrey		3107 E. Cervantes Street	Pensacola	32503	(850) 444-9595
FL	8638	Smith, Eric S.		4571 Watkins Street	Pace	32571	(850) 995-8889
FL	8640	Reulbach, Anthony S.		24428 SR 44	Sorrento	32766	(352) 483-1660
FL	8641	Welker, William L.		11200 E. Drive Martin Luther King Jr. Boulevard, Suite 104	Seffner	33584	(813) 571-5600
FL	8643	Longen, Jerry A.		3581 SW Archer Road, Commercial Suite 10	Gainesville	32608	(352) 505-5557
FL	8645	Sheikh, Ahsan M.		543 N. Orange Avenue	Green Cove Springs	32043	(904) 863-3130
FL	8647	Chak, Savak		5808 S. Tamiami Trail	Sarasota	34231	(941) 256-9000
FL	8648	Ramia, Jose Y.		210 N. U.S. Highway 27	Lady Lake	32159	(352) 775-1800
FL	8649	Corcoran, Neal T.		668 US Highway 1 North	Tequesta	33469	(561) 510-7979
FL	8801	Smith, Eric S.		5824 Dogwood Drive, Suite 222	Milton	32570	(850) 810-4333
FL	9450	Traenkner, Richard C.		2430 US Highway 27, Unit 370	Clermont	34714	(352) 227-1161
FL	9451	Longen, Jerry A.		221 Apollo Beach Boulevard, Unit 100/101	Apollo Beach	33572	(813) 773-7333
FL	9452	Vivas, Gaston		20330 Grande Oak Shoppes Boulevard, Unit 102	Estero	33928	(239) 719-2888
FL	9454	Welker, William L.		1005 Narcoossee Road	St. Cloud	34771	(407) 984-4777
FL	9455	Farace, Alvaro C.		1514 Immokalee Road, Unit 102	Naples	34110	(239) 438-4800
FL	9456	Wackerbarth, Matthew		9445 S. Suncoast Boulevard	Homosassa	34446	(352) 765-0600
FL	9457	Mullins, Erin M.		14640 State Road 70 East	Lakewood Ranch	34202	(941) 840-5858
FL	9458	Longen, Jerry A.		2197 NW 11th Drive, Suite 2185	Chiefland	32626	(352) 580-3999
FL	9459	Traenkner, Richard C.		11951 International Drive, Suite C5	Orlando	32821	(321) 430-0306
FL	9460	Longen, Jerry A.		17792 Aprile Drive	Lutz	33558	(813) 670-2424
FL	9461	Longen, Jerry A.		28850 State Road 54	Wesley Chapel	33544	(813) 397-8600
FL	9462	Welker, William L.		2164 34th Street South	St. Petersburg	33711	(727) 619-6161
FL	9463	Zabib, Mohammad A.		1339-1341 SW Gatlin Boulevard	Port St. Lucie	34953	(772) 218-1600
FL	9464	May, Roy Jeffrey		9100 A W. Highway 98	Pensacola	32506	(850) 495-3359
GA	3525	Rinehart, Bridget Fox		6072 Highway 53, Suite A	Braselton	30517	(706) 658-0000
GA	3527	Podsen, The Estate of Joseph M.		151 U.S. Highway 27 Bypass	Bremen	30110	(770) 537-5170
GA	3539	Podsen, The Estate of Joseph M.		118 North Oliver Street, Suite B	Elberton	30635	(470) 883-1133
GA	3559	Melson, James		3760 Sixes Road, Suite 120	Canton	30114	(943) 400-2300
GA	3560	Orcutt, Michael L.		837 Highway 400 S., Suite 170	Dawsonville	30534	(706) 216-3780
GA	3561	Orcutt, Michael L.		6525 Hiram-Douglasville Highway, Suite M	Douglasville	30134	(770) 489-3990
GA	3562	Rice, Jason E.		868 S. Main Street, Suite 7	Cleveland	30528	(706) 348-6610
GA	3563	Schroeder, James Michael		140 N. Lee Street	Forsyth	31029	(478) 219-4200

Exhibit B Traditional
as of December 31, 2023

GA	3564	Orcutt, Michael L.	1766 Hudson Bridge Road	Stockbridge	30281	(770) 474-3337
GA	3565	Shoemaker, Justin S.	3591 Chattanooga Road	Tunnel Hill	30755	(706) 673-3566
GA	3566	Orcutt, Michael L.	4602 Augusta Road	Garden City	31408	(912) 964-1455
GA	3567	Orcutt, Michael L.	15 Baker Road, Suite 1	Newnan	30265	(770) 251-5355
GA	3568	Accary, Jonathan	465-A Dacula Road	Dacula	30019	(770) 682-3337
GA	3569	Podsen, The Estate of Joseph M.	91 Highland Circle #114	East Ellijay	30540	(706) 697-3600
GA	3570	Podsen, The Estate of Joseph M.	199 Highway 515, Unit C	Blairsville	30512	(706) 745-5400
GA	3571	Orcutt, Michael L.	104 E. Highway 80	Pooler	31322	(912) 748-1616
GA	3572	Rinehart, Bridget Fox	4841 Hog Mountain Road	Flowery Branch	30542	(770) 965-0061
GA	3573	Shoemaker, Justin S.	206 N Main Street	Lafayette	30728	(706) 670-9800
GA	3574	Orcutt, Michael L.	88 Burnt Mountain Road	Jasper	30143	(706) 301-9030
GA	3575	Podsen, The Estate of Joseph M.	4295 Old Highway 76, Suite E	Blue Ridge	30513	(706) 632-4777
GA	3576	Teel, Ricky E.	410 N. Hutchinson Avenue	Adel	31620	(229) 896-2100
GA	3577	Liebert, Brian	644 Oak Street	Eastman	31023	(478) 309-3030
GA	3578	Orcutt, Michael L.	1347 W. Pine Street	Jesup	31545	(912) 588-0880
GA	3579	Orcutt, Michael L.	4990 Bill Gardner Parkway	Locust Grove	30248	(470) 713-8530
GA	3581	Orcutt, Michael L.	6175 Hickory Flat Highway, Suite #175	Canton	30114	(678) 493-8282
GA	3582	Orcutt, Michael L.	11242 Cumming Highway, Suite #111	Canton	30115	(678) 947-0900
GA	3583	Orcutt, Michael L.	12 Euharlee Road, Suite E	Cartersville	30120	(770) 607-0405
GA	3586	Rice, Jason E.	1087 East Franklin Street, Suite A	Hartwell	30643	(706) 377-7272
GA	3587	Rice, Jason E.	160-B Franklin Street	Clarksville	30523	(706) 754-9111
GA	3589	Podsen, The Estate of Joseph M.	7580 Springbox Drive, Suite 110	Fairburn	30213	(877) 883-9643
GA	3590	Orcutt, Michael L.	1468 Lafayette Parkway, Suite 140	LaGrange	30241	(706) 885-1103
GA	3591	Kline, Daniel H	5050 Wrightsboro Road	Grovetown	30813	(706) 868-0067
GA	3592	Podsen, The Estate of Joseph M.	1117 Highway 96, Suite 114	Kathleen	31047	(478) 778-3050
GA	3593	Orcutt, Michael L.	9165-D Roosevelt Highway	Palmetto	30268	(770) 463-1000
GA	4100	Rinehart, Bridget Fox	3190 Atlanta Highway, Suite 30	Athens	30606	(706) 354-1179
GA	4101	Rinehart, Bridget Fox	4018 Mundy Mill Road	Oakwood	30566	(770) 287-9111
GA	4105	Orcutt, Michael L.	510 Shorter Avenue	Rome	30165	(706) 235-0808
GA	4106	Podsen, The Estate of Joseph M.	611 A. E. Lamar	Americus	31709	(229) 928-2000
GA	4108	Schwartz, Kevin R.	117 Poplar Springs Road	Ringgold	30736	(706) 965-5000
GA	4109	Orcutt, Michael L.	449 S. Columbia Avenue, Suite G	Rincon	31326	(912) 826-5383
GA	4110	Kline, Daniel H	4357-E Washington Road	Evans	30809	(706) 868-8185
GA	4111	Shoemaker, Justin S.	3551 Highway 411 North	Chatsworth	30705	(706) 517-0600
GA	4112	Nagengast, Michael P.	1355 E. King Avenue, Suite A	Kingsland	31548	(912) 729-6100
GA	4113	Orcutt, Michael L.	594 Highway 61, Suite D	Villa Rica	30180	(770) 456-8750
GA	4114	Orcutt, Michael L.	11345 Tara Boulevard, Suite 3	Hampton	30228	(470) 491-2330

Exhibit B Traditional
as of December 31, 2023

GA	4116	Orcutt, Michael L.			2985 Villa Rica Highway, Suite B	Dallas	30157	(770) 445-4444
GA	4117	Orcutt, Michael L.			1879 Buford Highway	Buford	30518	(770) 945-1400
GA	4119	Menard, Michael E.			401-A East First Street	Vidalia	30474	(912) 537-1330
GA	4121	Orcutt, Michael L.			9925 Haynes Bridge Road #630	Alpharetta	30022	(770) 442-3030
GA	4122	Orcutt, Michael L.			13015 Abercorn Street, Suite D-3	Savannah	31419	(912) 920-5050
GA	4123	Orcutt, Michael L.			2555 Prado Lane #1420	Marietta	30066	(678) 460-0300
GA	4125	Orcutt, Michael L.			12195 Highway 92, Suite H	Woodstock	30188	(770) 924-3300
GA	4126	Hooper, Zachary			3641 Centerville Highway	Snellville	30039	(770) 985-1111
GA	4127	Orcutt, Michael L.			639 Thornton Road, Suite 104	Lithia Springs	30122	(678) 945-3990
GA	4128	Accary, Jonathan			2027 Lawrenceville-Suwanee Road, Suite 600	Suwanee	30024	(770) 995-0303
GA	4129	Orcutt, Michael L.			4154 Austell Powder Springs Road	Powder Springs	30127	(770) 943-3030
GA	4130	Orcutt, Michael L.			4724 Lower Roswell Road, Suite 101	Marietta	30068	(770) 641-7020
GA	4131	Accary, Jonathan			3406 Buford Highway	Duluth	30096	(770) 476-1274
GA	4132	Orcutt, Michael L.			2265 Towne Lake Parkway, Suite 104	Woodstock	30188	(770) 926-3619
GA	4133	Accary, Jonathan			5575 Lawrenceville Highway, Suite 300	Liburn	30047	(770) 717-0936
GA	4134	Accary, Jonathan			890 New Hope Road	Lawrenceville	30046	(770) 995-5500
GA	4135	Accary, Jonathan			2700-B Highway 29	Lawrenceville	30044	(678) 380-8585
GA	4138	Fox, Gregory B.			2420 Wisteria Boulevard, Suite 1	Snellville	30078	(770) 979-0123
GA	4139	Orcutt, Michael L.			3643 Cherokee Street	Kennesaw	30144	(770) 423-9696
GA	4140	Podsen, The Estate of Joseph M.			461 Ponce De Leon Avenue	Atlanta	30308	(404) 874-0030
GA	4141	Orcutt, Michael L.			3300 Buford Highway	Atlanta	30319	(404) 633-3231
GA	4142	Accary, Jonathan			5860 Jimmy Carter Boulevard, Suite 135	Norcross	30071	(678) 274-5656
GA	4143	Orcutt, Michael L.			250 E. Atlanta Road, Suite 238	Stockbridge	30281	(470) 568-3383
GA	4144	Podsen, The Estate of Joseph M.			45 Hudson Plaza	Fairburn	30213	(770) 969-0101
GA	4145	Podsen, The Estate of Joseph M.			3435 Roosevelt Highway	Atlanta	30349	(404) 768-0099
GA	4146	Podsen, The Estate of Joseph M.			101 S Main Street	Hiwassee	30546	(706) 896-3111
GA	4147	Bonanno, Joseph J.			5761 A Rockbridge Road	Stone Mountain	30087	(770) 469-1806
GA	4148	Orcutt, Michael L.			241 Atlanta Road	Cumming	30040	(770) 887-7710
GA	4149	Podsen, The Estate of Joseph M.			7490 Old National Highway, Suite No. 1800	Atlanta	30296	(678) 593-3030
GA	4150	Orcutt, Michael L.			515 North Central Avenue	Hapeville	30354	(404) 669-2666
GA	4151	Orcutt, Michael L.			3537 Highway 20 S.E.	Conyers	30208	(770) 922-9980
GA	4153	Melson, James			8302 Canton Highway (AKA 8302 Ball Ground Hwy)	Ball Ground	30107	(678) 454-5000
GA	4154	Bonanno, Joseph J.			6768 Browns Mill Road, Suite 100	Stonecrest	30038	(470) 893-2300
GA	4155	Bonanno, Joseph J.			7184 Rockbridge Road	Stone Mountain	30087	(678) 392-3130
GA	4156	Orcutt, Michael L.			3505 Baker Road NW, Suite 201	Acworth	30101	(770) 975-3030
GA	4157	Ventura, Rutbel I.			4235 Dallas Acworth Highway	Dallas	30132	(770) 505-3030
GA	4158	Orcutt, Michael L.			5310 Matt Highway, Suite 106	Cumming	30028	(470) 560-0430

Exhibit B Traditional
as of December 31, 2023

GA	4159	Wallace, Chip M.	607 S. Grant Street	Fitzgerald	31750	(229) 423-8777
GA	4160	Ventura, Rutbel I.	3880 Due West Road NW	Marreta	30064	(770) 423-1313
GA	4161	Ventura, Rutbel I.	458 Nathan Dean Bypass, Unit 4	Rockmart	30153	(470) 206-3200
GA	4162	Rice, Jason E.	230 Merchants Way	Cornelia	30531	(706) 776-3333
GA	4163	Orcutt, Michael L.	10995 Jones Bridge Road	Alpharetta	30201	(770) 475-3353
GA	4164	Sandford, John	104 Memorial Drive	Dahlonega	30533	(706) 864-2222
GA	4165	Orcutt, Michael L.	1861 Roanoke Road, Suite 6	LaGrange	30240	(706) 883-6900
GA	4166	Nagengast, Michael P.	803 N Peterson	Douglas	31533	(912) 384-3800
GA	4167	Orcutt, Michael L.	1078 Highway 19 North	Thomasston	30286	(706) 647-4555
GA	4169	Orcutt, Michael L.	645-A N. Glynn Street	Fayetteville	30214	(770) 460-8222
GA	4170	Orcutt, Michael L.	821 Bankhead Highway	Carrollton	30117	(770) 834-4494
GA	4172	Ventura, Rutbel I.	202 East Avenue	Cedartown	30125	(770) 748-0909
GA	4173	Orcutt, Michael L.	7768 McGinnis Ferry Road	Suwanee	30024	(770) 497-6688
GA	4174	Ventura, Rutbel I.	3999 Austell Road	Austell	30106	(678) 784-3660
GA	4178	Kline, Daniel H	1233 Washington Road	Thomson	30824	(706) 595-9656
GA	4179	Rinehart, Bridget Fox	2051 Experiment Station Road	Watkinsville	30677	(706) 769-8000
GA	4180	Orcutt, Michael L.	2163 Fairburn Road, Suite 4-G	Douglasville	30135	(770) 920-9200
GA	4181	Orcutt, Michael L.	3695-A Kings Highway	Douglasville	30135	(770) 949-2277
GA	4183	Accary, Jonathan	3595 Braselton Highway, Suites B & C	Dacula	30019	(678) 825-3330
GA	4184	Orcutt, Michael L.	228 Fairview Road	Ellenwood	30294	(770) 389-9300
GA	4186	Longen, Jerry A.	4644 Bemiss Road	Valdosta	31605	(229) 244-0030
GA	4187	Orcutt, Michael L.	5750 Milgen Road	Columbus	31907	(706) 568-0030
GA	4188	Podsen, The Estate of Joseph M.	2699 Watson Boulevard	Warner Robins	31093	(478) 923-4600
GA	4189	Orcutt, Michael L.	495 Johnny Mercer Boulevard, Suite 463-B5	Savannah	31410	(912) 897-5535
GA	4190	Orcutt, Michael L.	2100 Highway 54, Suite 104	Peachtree City	30269	(770) 487-5800
GA	4191	Melson, James	2230 Holly Springs Parkway	Canton	30115	(770) 479-3030
GA	4192	Orcutt, Michael L.	12460 Crabapple, Suite #102	Alpharetta	30004	(770) 664-4306
GA	4193	Orcutt, Michael L.	13695 Highway 9	Alpharetta	30004	(770) 664-9508
GA	4194	Shoemaker, Justin S.	430 Red Bud Road N.E.	Calhoun	30701	(706) 629-0500
GA	4195	Liezert, Brian	126 S. Main Street	Swainsboro	30401	(478) 289-7070
GA	5700	Orcutt, Michael L.	4763 Buford Highway	Atlanta	30341	(770) 458-2604
GA	5701	Orcutt, Michael L.	1439 Oxford Road NE	Atlanta	30307	(404) 370-3030
GA	5702	Orcutt, Michael L.	3175 Roswell Road, Suite B	Atlanta	30305	(404) 364-3030
GA	5703	Orcutt, Michael L.	3645 & 3647 Brown Bridge Road	Cumming	30028	(678) 208-0333
GA	5705	Orcutt, Michael L.	7529 Roswell Road, Suite #5	Atlanta	30350	(770) 390-3030
GA	5706	Orcutt, Michael L.	1007 Alpharetta Street, Suite 110B	Roswell	30075	(770) 587-0297
GA	5707	Orcutt, Michael L.	1959 Howell Mill Road NW	Atlanta	30318	(404) 352-3676

Exhibit B Traditional
as of December 31, 2023

GA	5708	Orcutt, Michael L.			955 Marietta Street NW	Atlanta	30318	(404) 872-3000
GA	5709	Diop, Souleymane			1303-A Columbia Drive	Decatur	30032	(404) 284-2122
GA	5710	Orcutt, Michael L.			30 E. Main Street	Hampton	30228	(678) 304-3045
GA	5711	Podsen, The Estate of Joseph M.			5819 Campbellton Road	Atlanta	30331	(404) 564-3300
GA	5712	Orcutt, Michael L.			6130 Roswell Road	Sandy Springs	30328	(404) 256-3030
GA	5713	Podsen, The Estate of Joseph M.			5207 Memorial Drive	Stone Mountain	30083	(404) 297-3030
GA	5714	Orcutt, Michael L.			806 W. Oglethorpe Highway	Hinesville	31313	(912) 622-6333
GA	5715	Orcutt, Michael L.			705 Highway 42 South	McDonough	30253	(770) 954-3030
GA	5717	Orcutt, Michael L.			12 West Washington Street	Newnan	30263	(770) 251-3241
GA	5718	Orcutt, Michael L.			2482 Jett Ferry Road	Dunwoody	30338	(770) 395-0716
GA	5719	Orcutt, Michael L.			1100 Hammond Drive, Suite 200	Sandy Springs	30328	(770) 451-1552
GA	5720	Orcutt, Michael L.			1209 Maple Street	Carrollton	30117	(770) 832-1316
GA	5721	Podsen, The Estate of Joseph M.			4691 Atlanta Road SE, Suite 140	Atlanta	30080	(404) 418-3033
GA	5722	Orcutt, Michael L.			107 Corporate Plaza Drive	LaGrange	30241	(706) 883-6010
GA	5723	Orcutt, Michael L.			20 O'Neil Street	Rome	30161	(706) 235-5544
GA	5725	Orcutt, Michael L.			406 West Taylor Street	Griffin	30223	(770) 229-1872
GA	5726	Orcutt, Michael L.			2165-A Cheshire Bridge Road NE	Atlanta	30324	(404) 636-5164
GA	5727	Orcutt, Michael L.			111 Willow Lane	McDonough	30253	(678) 593-3999
GA	5728	Orcutt, Michael L.			5796 Ogeechee Road, Suite C	Savannah	31405	(912) 581-2800
GA	5729	Orcutt, Michael L.			1200 West Avenue SW	Conyers	30013	(770) 922-2820
GA	5730	Orcutt, Michael L.			1839 Mount Zion Road, Suite V6	Morrow	30260	(770) 960-3030
GA	5731	Podsen, The Estate of Joseph M.			6445 Highway 85	Riverdale	30274	(770) 994-3030
GA	5732	Fox, Gregory B.			1132-1142 Athens Highway, Suite 201	Grayson	30017	(470) 242-7500
GA	5733	Orcutt, Michael L.			8496 Tara Boulevard	Jonesboro	30236	(770) 477-0030
GA	5735	Shoemaker, Justin S.			1010 Battlefield Parkway	Ft. Oglethorpe	30742	(706) 861-0030
GA	5736	Orcutt, Michael L.			851-B Joe Frank Harris Parkway	Cartersville	30120	(770) 386-4100
GA	5737	Orcutt, Michael L.			2323 Shallow Ford Road	Marietta	30060	(770) 928-2299
GA	5738	Podsen, The Estate of Joseph M.			465 Boulevard SE	Atlanta	30312	(470) 571-0101
GA	5739	Orcutt, Michael L.			2146 Roswell Road, Suite 100	Marietta	30062	(770) 977-6922
GA	5740	Ventura, Rutbel I.			1721 Powder Springs Road SW, Suite 104	Marietta	30064	(678) 354-6700
GA	5741	Ventura, Rutbel I.			59 Hillside Trace, Suite 105	Dallas	30157	(470) 744-0404
GA	5742	Podsen, The Estate of Joseph M.			2766 Cumberland Boulevard SE	Smyrna	30080	(770) 436-1313
GA	5743	Ventura, Rutbel I.			1230 Powers Ferry Rd SE, Suite B	Marietta	30067	(770) 955-5585
GA	5744	Orcutt, Michael L.			6274 Mableton Parkway SW	Mableton	30126	(770) 941-2959
GA	5745	Diop, Souleymane			3333 S Cobb Drive SE, Suite A	Smyrna	30080	(770) 436-0787
GA	5746	Ventura, Rutbel I.			49-E S. Marietta Parkway SW	Marietta	30064	(770) 426-0822
GA	5747	Orcutt, Michael L.			3545 Canton Road, Suite #500	Marietta	30066	(770) 926-0080

Exhibit B Traditional
as of December 31, 2023

GA	5748	Schroeder, James Michael	1909 N. Columbia Street	Milledgeville	31061	(478) 453-9455
GA	5749	Rinehart, Bridget Fox	10B Patrick Mill Road SW	Winder	30680	(770) 867-4111
GA	5750	Rinehart, Bridget Fox	396 Baxter Street	Athens	30605	(706) 543-3460
GA	5751	Accary, Jonathan	629 Scenic Highway, Suite C	Lawrenceville	30045	(770) 729-3322
GA	5752	Rinehart, Bridget Fox	2550 Limestone Parkway, Suite A	Gainesville	30501	(770) 535-1234
GA	5753	Rinehart, Bridget Fox	2824 Lexington Road	Athens	30605	(706) 353-3737
GA	5754	Rinehart, Bridget Fox	140 Martin Luther King Jr. Drive, Suite 140	Monroe	30655	(770) 267-8414
GA	5755	Accary, Jonathan	5175 S. Old Peachtree Road	Norcross	30092	(770) 441-2333
GA	5756	Accary, Jonathan	1560 Indian Trail Lilburn Road, Suite 116	Lilburn	30093	(770) 564-1311
GA	5757	Podsen, The Estate of Joseph M.	3341 Martin Luther King Jr. Drive	Atlanta	30331	(470) 300-9998
GA	5758	Podsen, The Estate of Joseph M.	1195 Fairburn Road, Suite 110	Atlanta	30331	(404) 344-3435
GA	5759	Orcutt, Michael L.	4137 Highway 278 NW	Covington	30014	(770) 787-2705
GA	5760	Rice, Jason E.	19 West Currahee Street	Toccoa	30577	(706) 886-0481
GA	5761	Kline, Daniel H	2514 Tobacco Road, Suite A	Hephzibah	30815	(706) 798-5575
GA	5762	Eckburg, John W.	3100 Washington Road	Augusta	30907	(706) 863-2262
GA	5763	Eckburg, John W.	46 13th Street	Augusta	30901	(706) 481-2009
GA	5764	Shoemaker, Justin S.	222 W Cuyler	Dalton	30720	(706) 226-1008
GA	5765	Liezert, Brian	213 W. Jackson Street	Dublin	31021	(478) 272-7831
GA	5766	Liezert, Brian	106 W. Beech Street	Cochran	31014	(478) 239-1600
GA	5767	Podsen, The Estate of Joseph M.	4919 Flat Shoals Parkway, Suite 122	Decatur	30034	(470) 833-1120
GA	5768	Newton, Michael R.	1600 Fredrica Road	St Simons Island	31522	(912) 638-1166
GA	5769	Nagengast, Michael P.	108 Scranton	Brunswick	31525	(912) 267-0822
GA	5770	Orcutt, Michael L.	9177 Maime Road	Fort Moore	31905	(706) 689-5533
GA	5771	Orcutt, Michael L.	1646-B Bradley Park Drive	Columbus	31904	(706) 322-6630
GA	5772	Orcutt, Michael L.	2534 Wynnton Road #C	Columbus	31906	(706) 321-1141
GA	5773	Sorrelle, Tanya	505 S. Scott Street	Bainbridge	39819	(229) 243-0992
GA	5774	Orcutt, Michael L.	4908 Buena Vista Road, Suite F	Columbus	31907	(706) 689-7676
GA	5775	Podsen, The Estate of Joseph M.	233 GA Highway 49	Byron	31008	(478) 654-7272
GA	5776	Podsen, The Estate of Joseph M.	262 Cordele Road	Albany	31705	(229) 800-8444
GA	5777	Podsen, The Estate of Joseph M.	305 W. Franklin Street	Sylvester	31791	(229) 463-7090
GA	5778	Teel, Ricky E.	1818 1st Avenue SE	Moultrie	31768	(229) 985-6685
GA	5779	Nagengast, Michael P.	105 E. 8th Street	Tifton	31794	(229) 386-4800
GA	5780	Orcutt, Michael L.	327-A Memorial Drive	Hinesville	31313	(912) 368-3373
GA	5781	Orcutt, Michael L.	1932 E. Montgomery Crossroad, Suite 102	Savannah	31406	(912) 921-0030
GA	5782	Orcutt, Michael L.	1900 E. Victory Drive D-14	Savannah	31404	(912) 651-6001
GA	5783	Orcutt, Michael L.	4369 Suwanee Dam Road, Suite 104	Suwanee	30024	(678) 765-3333
GA	5784	Diop, Souleymane	2440 Wesley Chapel Road, Suite D	Decatur	30035	(404) 284-0806

Exhibit B Traditional
as of December 31, 2023

GA	5785	Orcutt, Michael L.		1550 Chandler Road #F	Statesboro	30458	(912) 681-4326
GA	5786	Orcutt, Michael L.		1004 Abercorn Street, Suite B	Savannah	31404	(912) 721-3000
GA	5787	Liezert, Brian		50 Surrey Plaza	Hawkinsville	31036	(478) 309-2100
GA	5788	Nagengast, Michael P.		2506 Osborne Street	St. Marys	31558	(912) 673-6100
GA	5790	Podsen, The Estate of Joseph M.		2278-B Moody Road	Warner Robbins	31088	(478) 929-0151
GA	5791	Longen, Jerry A.		210 Northside Drive	Valdosta	31602	(229) 247-6341
GA	5792	Podsen, The Estate of Joseph M.		4682 Forsythe Road	Macon	31210	(478) 757-2999
GA	5793	Longen, Jerry A.		1025 E Jackson Street	Thomasville	31792	(229) 228-7660
GA	5794	Liezert, Brian		1113 Washington Street	Perry	31069	(478) 987-4877
GA	5795	Nagengast, Michael P.		727 Knight Avenue	Waycross	31501	(912) 285-9098
GA	5797	Orcutt, Michael L.		1682 Buford Highway	Cumming	30344	(770) 844-0747
GA	8050	Shoemaker, Justin S.		12316 Highway 27	Summerville	30747	(706) 857-5868
GA	8865	Rinehart, Bridget Fox		1841 Walnut Avenue, Suite 300	Covington	30014	(470) 444-0050
GA	8866	Vellner, Andrew		371 W Parker Street, Suite A	Baxley	31513	(912) 333-8008
GA	8867	Rinehart, Bridget Fox		1460 Winder Highway, Unit B	Jefferson	30542	(706) 367-1004
GA	8868	Hamilton, Ronald Christopher		110 Cove Road	Chickamauga	30707	(706) 375-3000
GA	8869	Podsen, The Estate of Joseph M.		600 New Street, Suite A	Macon	31201	(478) 219-4400
GA	8870	Podsen, The Estate of Joseph M.		2410 DeKalb Medical Parkway	Lithonia	30058	(678) 951-1900
GA	8871	Kline, Daniel H		315 South Belair Road	Martinez	30907	(706) 504-3326
GA	8872	Podsen, The Estate of Joseph M.		4319 Hartley Bridge, Suite 120	Macon	31216	(478) 803-9500
GA	8873	Orcutt, Michael L.		6010 Muscogee Creek Way Bldg .15068	Fort Moore	31905	(706) 984-7070
GA	8874	Ventura, Rutbel I.		2483 Cedarcrest Road, Suite 205	Acworth	30101	(678) 996-8888
GA	8875	Accary, Jonathan		824 Hull Road	Athens	30601	(706) 552-1213
GA	8876	Podsen, The Estate of Joseph M.		530 Joseph E. Lowery Boulevard, Suite F	Atlanta	30310	(404) 917-1818
GA	8877	Accary, Jonathan		4121 Lavista Road	Tucker	30084	(770) 496-1000
GA	8879	Shoemaker, Justin S.		2518 Cleveland Highway, Suite 14	Dalton	30721	(706) 529-7499
GA	8881	Kline, Daniel H		Bldg #25722	Ft. Gordon	30905	(706) 863-6211
GA	8884	Podsen, The Estate of Joseph M.		2405 Dawson Road	Albany	31707	(229) 317-7777
GA	8888	Eckburg, John W.		3336 Wrightsboro Road, Suite 6	Augusta	30909	(706) 736-6788
GA	8890	Schroeder, James Michael		1156 Walmart Circle	Sandersville	31082	(478) 309-2500
GA	8891	Nagengast, Michael P.		222 Hyde Park Commons	Brunswick	31523	(912) 264-5055
GA	8892	Rinehart, Bridget Fox		1122 Dawsonville Highway, Suite 103	Gainesville	30506	(770) 531-0226
GA	8893	Menard, Michael E.		706 West Main Street	Claixton	30417	(912) 732-1300
GA	8895	Nagengast, Michael P.		3509 US Highway 84	Blackshear	31516	(912) 807-8700
GA	8896	Accary, Jonathan		2120 N. Broad Street	Commerce	30529	(470) 499-2900
GA	8897	Longen, Jerry A.		1319 Lakes Boulevard	Lake Park	31636	(229) 559-9997
GA	8898	Melson, James		1451 Riverstone Parkway	Canton	30114	(678) 880-0060

Exhibit B Traditional
as of December 31, 2023

GA	8899	Orcutt, Michael L.	5740 Steeplechase Boulevard, Suite 102	Cumming	30040	(770) 406-2080
GA	8922	Orcutt, Michael L.	3745 Highway 17, Unit 100	Richmond Hill	31324	(912) 727-3997
GA	8923	Rinehart, Bridget Fox	504 Hayes Lake Road	Statham	30666	(770) 725-2888
GA	8967	Podsen, The Estate of Joseph M.	2520 Bouldercrest Road	Atlanta	30316	(404) 241-7900
GA	8969	Longen, Jerry A.	550 U.S. Highway 84 East	Cairo	31728	(229) 377-1800
GA	8974	Rinehart, Bridget Fox	3606 Thompson Bridge Road	Gainesville	30506	(770) 297-6600
GA	8981	Rinehart, Bridget Fox	5141 Highway 81	Loganville	30052	(770) 554-4744
GA	8997	Teel, Ricky E.	702 Tifton Road	Nashville	31639	(229) 686-2200
HI	18001	Rompel, Micheal SC	45-934 Kamehameha Highway, Unit 1A	Kaneohe	96744	(808) 468-8080
HI	18005	Rompel, Micheal SC	535 Wisser Road	Honolulu	96819	(808) 744-1500
HI	18012	Rompel, Micheal SC	Building 694 McCormack Road	Wahiawa	96857	(808) 744-0137
HI	18013	Rompel, Micheal SC	Alkahi Park Shopping Center, 26 Hoolai St, #800	Kailua	96734	(808) 254-6433
HI	18018	Rompel, Micheal SC	91-1001 Kaimalie Street #109	Ewa Beach	96706	(808) 689-8323
HI	18021	Rompel, Micheal SC	54-316 Kamehameha Highway #8	Hauula	96717	(808) 293-2300
HI	18023	Rompel, Micheal SC	315 Maka 'ala Street, Suite 109	Hilo	96720	(808) 825-4030
HI	18024	Rompel, Micheal SC	68-1820 Waikoloa Road	Waikoloa Village	96738	(808) 333-5463
HI	18027	Rompel, Micheal SC	67-1185 Mamalahoa Highway	Kamuela	96743	(808) 885-4400
HI	18028	Rompel, Micheal SC	75-1027 Henry Street	Kailua-Kona	96740	(808) 329-9500
HI	18030	Rompel, Micheal SC	Hickam Bldg. #1756, Kuntz Avenue, Hickam AFB	Honolulu	96853	(808) 853-4917
HI	18031	Rompel, Micheal SC	Bldg. 752, Schofield Barracks	Wahiawa	96857	(808) 624-0702
HI	18033	Rompel, Micheal SC	4618 Kilauea Avenue, Unit 6	Honolulu	96816	(808) 726-2221
HI	18034	Rompel, Micheal SC	888 Alimanu Drive	Honolulu	96819	(808) 836-3100
HI	18036	Rompel, Micheal SC	4850 Kapolei Parkway #B-1	Kapolei	96707	(808) 492-1100
HI	18037	Rompel, Micheal SC	95-1057 Ainamakua Drive, Building F-1	Mililani	96789	(808) 888-0030
HI	18038	Rompel, Micheal SC	440 Kilani Avenue	Wahiawa	96786	(808) 200-2000
HI	18039	Rompel, Micheal SC	1160 Kuala Street, Space 202	Pearl City	96782	(808) 200-1500
HI	18042	Rompel, Micheal SC	934 Keeaumoku Street	Honolulu	96814	(808) 312-3030
HI	18045	Rompel, Micheal SC	841 Bishop Street #142	Honolulu	96813	(808) 427-2222
HI	18046	Rompel, Micheal SC	175 Paoakalani Avenue	Honolulu	96815	(808) 773-7777
HI	18047	Rompel, Micheal SC	94-673 Kupuohi Street #B207	Waipahu	96797	(808) 888-6161
HI	18048	Rompel, Micheal SC	15-2714 Pahoia Village Road, Unit I-1	Pahoia	96778	(808) 491-0111
HI	18050	Rompel, Micheal SC	52 Maui Lani Parkway, D-6	Wailuku	96793	(808) 213-0303
HI	18052	Rompel, Micheal SC	80 Hookele Street, Suite 410	Kahului	96732	(808) 793-3434
HI	18060	Rompel, Micheal SC	4454 Nuhou Street, Suite 401	Lihue	96766	(808) 212-1010
IA	1700	Peterson, Wayne A.	122 Hayward Avenue	Ames	50010	(515) 292-3030
IA	1701	Peterson, Wayne A.	522 Story Street	Boone	50036	(515) 236-5747
IA	1702	Peterson, Wayne A.	10 Lafrentz Lane	Marshalltown	50158	(641) 752-3030

Exhibit B Traditional
as of December 31, 2023

IA	1703	Bjerke, Stuart A.	301 N. Wapello Street	Ottumwa	52501	(641) 684-5151
IA	1704	Lockhart, Eric J.	501 Bremer Avenue	Waverly	50677	(319) 483-9444
IA	1705	Bjerke, Stuart A.	2200 NW 159th Street, Suite 100	Clive	50325	(515) 987-0770
IA	1707	Bjerke, Stuart A.	725 Pacha Parkway, Suite 4	North Liberty	52317	(319) 853-0330
IA	1710	Peterson, Wayne A.	3701 East 14th, Suite 101	Des Moines	50313	(515) 505-3230
IA	1711	Peterson, Wayne A.	1430 East Army Post Road	Des Moines	50320	(515) 287-3030
IA	1712	Bower, Brian Patrick	710 Common Place	Adel	50003	(515) 581-7020
IA	1713	Peterson, Wayne A.	2914 E. University	Des Moines	50317	(515) 265-0030
IA	1714	Peterson, Wayne A.	3105 Douglas Ave	Des Moines	50310	(515) 274-3030
IA	1715	Peterson, Wayne A.	7620 Douglas Ave	Urbandale	50322	(515) 276-0030
IA	1716	Peterson, Wayne A.	1011 N. Jefferson Way, Suite 400	Indianola	50125	(515) 552-1030
IA	1719	Peterson, Wayne A.	302 Lincoln Way, Suite 102	Ames	50010	(515) 441-7464
IA	1720	Peterson, Wayne A.	401 Grand Avenue	Des Moines	50309	(515) 288-3030
IA	1722	Peterson, Wayne A.	4825 E. P. True Parkway, Suite 109	West Des Moines	50265	(515) 226-0030
IA	1723	Peterson, Wayne A.	902 Army Post Road	Des Moines	50315	(515) 285-3030
IA	1724	Bjerke, Stuart A.	110 N. Ankeny Boulevard, Suite 400	Ankeny	50023	(515) 963-0000
IA	1725	Bjerke, Stuart A.	1002 SE National Drive	Ankeny	50021	(515) 650-8777
IA	1729	Ocel, Scott A.	619 E. Le Claire Road	Eldridge	52748	(563) 279-0007
IA	1730	Bjerke, Stuart A.	1430 5th Avenue S.	Fort Dodge	50501	(515) 576-1111
IA	1733	Bjerke, Stuart A.	2441 James Street, Suite #1	Coralville	52241	(319) 499-1900
IA	1735	Crech, Scott	1606 First Avenue E.	Newton	50208	(641) 792-6655
IA	1737	Lockhart, Eric J.	2024 College Street	Cedar Falls	50613	(319) 266-3333
IA	1738	Lockhart, Eric J.	2013 Central Avenue	Dubuque	52001	(563) 556-2300
IA	1739	Lockhart, Eric J.	1685 John F. Kennedy Road	Dubuque	52002	(563) 557-3030
IA	1740	Saghah, Hamed	2931 7th Avenue, Suite 100	Marion	52302	(319) 377-0030
IA	1742	Pedersen, Blane C.	1121 Blairs Ferry Road NE 400	Cedar Rapids	52402	(319) 393-3030
IA	1743	Saghah, Hamed	2460 Edgewood Road SW, Suite 300	Cedar Rapids	52404	(319) 366-3030
IA	1744	Peterson, Wayne A.	408 8th Street SW	Altoona	50009	(515) 957-0003
IA	1745	Peterson, Wayne A.	6110 NW 86th Street, Suite 103	Johnston	50131	(515) 313-0305
IA	1746	Bjerke, Stuart A.	3200 Agency Street	Burlington	52601	(319) 752-3030
IA	1747	Ocel, Scott A.	902 W. Kimberly Road	Davenport	52806	(563) 362-2424
IA	1750	Bjerke, Stuart A.	1534 S. Gilbert Street, Suite 300	Iowa City	52240	(319) 338-0030
IA	1753	Ocel, Scott A.	1926 Brady Street	Davenport	52803	(563) 323-3030
IA	1756	Bjerke, Stuart A.	2110-A Park Avenue	Muscatine	52769	(563) 264-3030
IA	1758	Ocel, Scott A.	2420 18th Street	Bettendorf	52722	(563) 359-7777
IA	1759	Ocel, Scott A.	1122 North 2nd Street	Clinton	52732	(563) 241-7900
IA	1762	Stoll, Norman L.	1451 Ansborough Avenue	Waterloo	50701	(319) 291-3030

Exhibit B Traditional
as of December 31, 2023

IA	1764	Lockhart, Eric J.			1805 La Porte Road	Waterloo	50702	(319) 486-4488
IA	1765	Ocel, Scott A.			3025 Mt. Vernon Road SE, Suite C	Cedar Rapids	52403	(319) 774-2440
IA	1766	Ocel, Scott A.			1540 Washington Street	Pella	50219	(641) 416-4001
IA	1769	Graves, Susan L.			2004 West Broadway	Council Bluffs	51501	(712) 325-8848
IA	1770	Graves, Susan L.			4202 Morningside Avenue	Sioux City	51106	(712) 274-2100
IA	1771	Graves, Susan L.			1422 Hamilton Boulevard	Sioux City	51103	(712) 252-5600
IA	1773	Hawkins, Ryan G.			200 5th Avenue NW	LeMars	51031	(712) 305-0505
IA	1775	Bjerke, Stuart A.			208 A Avenue	Oskaloosa	52577	(641) 569-9977
IA	1777	Bower, Brian Patrick			806 Laurel Street	Creston	50801	(641) 362-4777
IA	1780	Hawkins, Ryan G.			3425 Highway 71 South	Spirit Lake	51360	(712) 759-7777
IA	1785	Bower, Brian Patrick			403 1st Avenue, Suite 902	Perry	50220	(515) 642-3330
IA	1788	Mabrey, Jeffrey M.			1027 Main Street	Keokuk	52632	(319) 524-9770
IA	1790	Gritz, Paul M.			1112 N. Federal Avenue	Mason City	50401	(641) 423-2330
IA	1791	Hawkins, Ryan G.			1721 1st Street Avenue West	Spencer	51301	(712) 346-5555
ID	7036	Bulkley, Scott Arthur			513 Main Street	Lewiston	83501	(208) 746-9595
ID	7251	Bittner, Chad R.			1700 N. Whitley Drive	Fruitland	83619	(208) 452-6755
ID	7301	Mikelonis, Philip F.			2273 S. Vista Avenue	Boise	83705	(208) 343-5995
ID	7302	Mikelonis, Philip F.			10396 Fairview Avenue	Boise	83704	(208) 377-5201
ID	7303	Mikelonis, Philip F.			5000 W. State Street	Boise	83703	(208) 853-6060
ID	7304	Mikelonis, Philip F.			2132 S. Broadway Avenue	Boise	83706	(208) 345-5551
ID	7305	McComas, Sean E.			945 W. Broadway	Idaho Falls	83402	(208) 523-7530
ID	7306	McComas, Sean E.			1675 Market Way	Ammon	83406	(208) 523-3030
ID	7307	Mikelonis, Philip F.			1123 E. Cleveland Boulevard	Caldwell	83605	(208) 454-8888
ID	7308	Mikelonis, Philip F.			1011 12th Avenue S.	Nampa	83651	(208) 465-5555
ID	7310	Mikelonis, Philip F.			5720 Cleveland Boulevard, Suite 101	Caldwell	83607	(208) 453-7111
ID	7311	Mikelonis, Philip F.			1701 W. Cherry Lane	Meridian	83642	(208) 887-6400
ID	7312	Mikelonis, Philip F.			950 Airbase Road (aka 950 W. 600 S.)	Mountain Home	83647	(208) 587-5000
ID	7313	Kearns, David			20 E. Bullion Street	Hailey	83333	(208) 578-2100
ID	7314	Bittner, Chad R.			2716 S. Lincoln Avenue, Suite D	Jerome	83338	(208) 644-1300
ID	7315	Mikelonis, Philip F.			8966 W. Arden Street	Boise	83709	(208) 658-5555
ID	7316	Mikelonis, Philip F.			6456 S. Federal Way	Boise	83716	(208) 968-7775
ID	7317	Hightower, Melissa A.			9020 W. Hess Street	Hayden	83835	(208) 772-8210
ID	7318	Hightower, Melissa A.			15640 Highway 41, Suite 600	Rathdrum	83858	(208) 687-3480
ID	7320	Bulkley, Scott Arthur			317 W. 6th Street, Suite 105	Moscow	83843	(208) 883-1555
ID	7321	Hightower, Melissa A.			50 West Neider Avenue	Coeur d'Alene	83815	(208) 765-1216
ID	7322	Bulkley, Scott Arthur			621 Bryden Avenue, Unit C	Lewiston	83501	(208) 743-9595
ID	7324	Hightower, Melissa A.			3904 E. Mullan Avenue, Suite D	Post Falls	83854	(208) 457-1216

Exhibit B Traditional
as of December 31, 2023

ID	7325	Tetachuk, Darren B.	316 N Fifth Avenue	Sandpoint	83864	(208) 263-6600
ID	7326	Mikelonis, Philip F.	3327 North Eagle Road	Meridian	83642	(208) 996-3232
ID	7327	Mikelonis, Philip F.	498 E. State Street	Eagle	83605	(208) 939-4440
ID	7328	Hightower, Melissa A.	2 N. Division Street	Kellogg	83837	(208) 682-1500
ID	7329	Bittner, Chad R.	1027 East Kuna Road	Kuna	83634	(208) 922-3399
ID	7331	Bittner, Chad R.	715 US Highway 30	Buhl	83316	(208) 537-7333
ID	7332	Mikelonis, Philip F.	10580 W. State Street, Suite 104	Star	83669	(208) 609-6575
ID	7333	Turner, David L.	110 Knudsen Boulevard, Suite C	Chubbuck	83202	(208) 237-5500
ID	7341	McComas, Sean E.	526 North State Street	Shelley	83274	(208) 419-3322
ID	7351	Bittner, Chad R.	652 E. 1st Street	Weiser	83672	(208) 718-1100
ID	7359	McComas, Sean E.	208 S. State	Preston	83263	(208) 417-3100
ID	7364	McComas, Sean E.	1525 Lincoln Road	Idaho Falls	83401	(208) 419-3340
ID	7370	Clysdale, William Patrick	1869 Addison Avenue E	Twin Falls	83301	(208) 969-9972
ID	7373	Bittner, Chad R.	1103 South Washington	Emmett	83617	(208) 963-4733
ID	7377	Bittner, Chad R.	2295 E. Cinema Drive	Meridian	83642	(208) 287-0004
ID	7383	Hightower, Rhett D. H.	608 N. Spokane Street	Post Falls	83854	(208) 618-2277
ID	7390	Turner, David L.	275 Yellowstone Avenue	Pocatello	83201	(208) 232-4332
ID	7391	Turner, David L.	155 West Main, Suite #1	Rexburg	83440	(208) 356-9555
ID	7392	Clysdale, William Patrick	532 Washington Street North	Twin Falls	83301	(208) 734-3960
ID	7395	Mikelonis, Philip F.	2934 E Greenhurst Road, Suite G	Nampa	83686	(208) 467-7778
ID	7397	McComas, Sean E.	1233 Parkway Drive, Suite D	Blackfoot	83221	(208) 782-0303
ID	7398	Bittner, Chad R.	216 E. 5th Street N.	Burley	83318	(208) 647-0333
ID	7399	McComas, Sean E.	151 W. Main Street	Rigby	83442	(208) 745-3030
IL	2023	Montez, Raymond J.	248 Republic Avenue	Joliet	60435	(815) 780-2900
IL	2538	Duvall, Samuel Edward	820 E. Main Street	Olney	62450	(618) 392-8000
IL	2700	Ratterman, Mark B.	801 South Ridge Road	Minooka	60447	(815) 317-3232
IL	2701	Mabrey, Jeffrey M.	123 W. Calhoun Street	Macomb	61455	(309) 836-3030
IL	2702	Ratterman, Mark B.	719 North Henderson Street	Galesburg	61401	(309) 344-3030
IL	2703	Hemingway, Matthew	9022 S. Cicero Avenue	Oak Lawn	60453	(708) 425-9191
IL	2704	Ambre, Timothy J.	950 N. Farnsworth	Aurora	60505	(630) 898-5710
IL	2705	Gronemann, James W.	4510 Oakton Street	Skokie	60076	(847) 675-7711
IL	2706	Ambre, Timothy J.	2987 Kirk Road, Suite 103	Aurora	60502	(630) 454-7070
IL	2707	Hudrick, Robert E.	2144 Sand Lake	Lindenhurst	60046	(224) 372-9030
IL	2708	Hudrick, Robert E.	1169 Lee Street	Des Plaines	60016	(847) 298-8610
IL	2709	Lindeman, Kenneth R.	4707 S. Kedzie	Chicago	60632	(773) 938-4040
IL	2710	Hudrick, Robert E.	1009 N. Northwest Highway	Park Ridge	60068	(847) 692-9120
IL	2711	Ambre, Timothy J.	1036 S. York Road	Elmhurst	60126	(630) 834-0200

Exhibit B Traditional
as of December 31, 2023

IL	2712	Gronemann, James W.	2455 W. Fullerton Avenue	Chicago	60647	(773) 276-9800
IL	2713	Montez, Raymond J.	4003 Plainfield Naperville Road, Suite 119	Naperville	60464	(630) 360-3200
IL	2715	Gronemann, James W.	133 N. Arlington Heights Road	Buffalo Grove	60089	(847) 459-1803
IL	2716	Botrice, Morice B.	5008 N Pulaski Road	Chicago	60630	(773) 685-3030
IL	2718	Hudrick, Robert E.	2211 Grand Avenue	Waukegan	60085	(847) 360-0800
IL	2719	Botrice, Morice B.	5235 N. Kedzie Avenue	Chicago	60660	(773) 764-3400
IL	2720	Montez, Raymond J.	2600 Martin Luther King Jr Drive	North Chicago	60064	(847) 473-3030
IL	2721	Hudrick, Robert E.	450 E. Dundee Road	Palatine	60074	(847) 359-4200
IL	2723	Gronemann, James W.	572 W. Army Trail Road	Carol Stream	60188	(630) 454-7200
IL	2724	Lindeman, Kenneth R.	211 Army Trail Road	Glendale Heights	60139	(630) 893-3030
IL	2725	Montez, Raymond J.	158 N. Bolingbrook Drive	Bolingbrook	60440	(630) 759-7421
IL	2726	Gronemann, James W.	686 Barrington Road	Streamwood	60107	(630) 830-6700
IL	2730	Khan, Muhammad Hayat	901 Lucinda Avenue, Suite I	DeKalb	60115	(815) 756-3626
IL	2731	Ambre, Timothy J.	686 W. Roosevelt Road	Glen Ellyn	60137	(630) 984-7474
IL	2733	Atallah, Akram	18401 Burnham Avenue	Lansing	60438	(708) 895-8848
IL	2735	Fischer, Gregory D.	7658 Madison Street	Forest Park	60130	(708) 366-6000
IL	2736	Bronzelli, Anthony S.	19310 South LaGrange Road	Mokena	60448	(708) 478-1200
IL	2737	Ratterman, Mark B.	1514 W. Market Street	Bloomington	61701	(309) 603-2121
IL	2738	Ambre, Timothy J.	1450 West Main Street	St. Charles	60174	(630) 377-3030
IL	2740	Fischer, Gregory D.	403 E. North Avenue	Lombard	60148	(630) 385-0444
IL	2741	Lockhart, Eric J.	3708 14th Avenue	Rock Island	61201	(309) 788-1111
IL	2744	Lockhart, Eric J.	435 Avenue of the Cities	East Moline	61244	(309) 792-0030
IL	2746	Osel, Scott A.	1602 S. Galena Avenue	Dixon	61021	(888) 202-0871
IL	2748	Lockhart, Eric J.	4200 Black Hawk Road	Rock Island	61201	(309) 644-4243
IL	2750	Montez, Raymond J.	2405 Caton Farm Road	Cresthill	60435	(815) 436-8000
IL	2751	Hudrick, Robert E.	646 Rt. 173	Antioch	60002	(847) 838-3030
IL	2753	Marks III, Loren E.	205 West Deyoung Street	Marion	62959	(618) 993-3030
IL	2755	Gronemann, James W.	3103 N. Clark Street	Chicago	60657	(773) 528-3030
IL	2756	Botrice, Morice B.	3144 W. Devon Avenue	Chicago	60659	(773) 743-3030
IL	2758	Montez, Raymond J.	604 East 9th Street	Lockport	60441	(815) 287-0030
IL	2759	Lindeman, Kyle W	1415 Irving Park Road, Unit C	Chicago	60613	(773) 871-3030
IL	2765	Montez, Raymond J.	9 Prairie Avenue, Suite B	Highwood	60040	(847) 433-6441
IL	2770	Montez, Raymond J.	444 N. Eola Road, Unit 105	Aurora	60502	(630) 425-4400
IL	2771	Hudrick, Robert E.	1141 S. Arlington Hts. Road #A	Arlington Hts.	60005	(847) 758-1010
IL	2773	Burch, Nicholas M.	716 S. Logan Street	West Frankfort	62896	(618) 937-4636
IL	2776	Lindeman, Kenneth R.	24 S. Prospect Avenue	Clarendon Hills	60514	(630) 654-3030
IL	2777	Fischer, Gregory D.	329 Chicago Avenue	Oak Park	60302	(708) 524-8111

Exhibit B Traditional
as of December 31, 2023

IL	2778	Hudrick, Robert E.	308 W. Rollins Road	Round Lake Beach	60073	(847) 740-3030
IL	2779	Lindeman, Kenneth R.	5018 S. Pulaski Road	Chicago	60632	(773) 582-4040
IL	2781	Montez, Raymond J.	1009 Green Bay Road	Winnetka	60093	(847) 835-1500
IL	2782	Reyes, Jair A	115-B W Rockland Road	Libertyville	60048	(847) 367-6200
IL	2784	Lindeman, Kenneth R.	6613 Cermak Road	Berwyn	60402	(708) 749-4949
IL	2785	Montez, Raymond J.	15515 S. Route 59, Unit 109	Plainfield	60544	(630) 426-1500
IL	2786	Arroyave, Mauricio	6168 Northwest Highway	Crystal Lake	60014	(815) 455-1515
IL	2787	Gronemann, James W.	837 South Lake Street	Mundelein	60060	(847) 949-7770
IL	2788	Vickers, Chad	1234 S. Canal Street	Chicago	60607	(312) 666-5900
IL	2789	Gronemann, James W.	2231 N. Lincoln Avenue	Chicago	60614	(773) 665-7232
IL	2791	Atallah, Akram	509 North Orleans Street	Chicago	60654	(312) 481-8333
IL	2792	Gronemann, James W.	233 Dundee Avenue	Elgin	60120	(847) 697-3030
IL	2793	Gronemann, James W.	4196 IL Route 83, Unit C	Long Grove	60047	(224) 900-1040
IL	2794	Atallah, Akram	1088 Sibley Boulevard	Calumet	60409	(708) 808-2121
IL	2795	Burch, Nicholas M.	701 South Greenbriar Road	Cartersville	62918	(618) 985-3030
IL	2797	Arroyave, Mauricio	1944 McDonald Road	South Elgin	60177	(847) 289-2200
IL	2801	Ratterman, Mark B.	2205 E. Oakland Avenue	Bloomington	61701	(309) 665-0505
IL	2802	Ratterman, Mark B.	305 W. Beaufort Street	Normal	61761	(309) 454-5111
IL	2803	Ratterman, Mark B.	1135 W. Wood Street	Decatur	62521	(217) 422-2244
IL	2804	Ratterman, Mark B.	2512 N. Water Street	Decatur	62526	(217) 747-8383
IL	2805	Ratterman, Mark B.	1948 E. Eldorado Street	Decatur	62521	(217) 429-4155
IL	2807	Ambre, Timothy J.	2801 Ogden Avenue	Lisle	60532	(630) 355-5700
IL	2808	Lindeman, Kenneth R.	619 W. Roosevelt Road	Wheaton	60187	(630) 871-3030
IL	2809	Ratterman, Mark B.	501 Commerce Drive, Suite C	Savoy	61874	(217) 788-9090
IL	2810	Ratterman, Mark B.	425 N. Western Avenue	Peoria	61606	(309) 637-3315
IL	2812	Ratterman, Mark B.	1910 E. College Avenue	Normal	61761	(309) 204-4500
IL	2814	Ratterman, Mark B.	200 E. Norris Drive	Ottawa	61350	(815) 324-2100
IL	2815	Al-Farah, Ayed T.	3918-20 N. Cicero Avenue	Chicago	60641	(773) 249-7222
IL	2817	Ratterman, Mark B.	11 E. Jackson Street	Morton	61550	(309) 266-7777
IL	2819	Ratterman, Mark B.	1002 Shooting Park Road	Peru	61354	(815) 780-2929
IL	2820	Ratterman, Mark B.	3320 N. Prospect Road #B	Peoria	61603	(309) 686-1676
IL	2821	Ratterman, Mark B.	7060 Burrough Avenue, Suite D	Plano	60545	(630) 454-7600
IL	2822	Ratterman, Mark B.	415 Keokuk Street	Lincoln	62656	(217) 735-3333
IL	2823	Ratterman, Mark B.	1613 N. Bloomington Street	Streator	61364	(779) 800-6100
IL	2824	Gronemann, James W.	325 E. Rand Road	Arlington Heights	60004	(847) 259-8110
IL	2825	Ratterman, Mark B.	1810 Court Street	Pekin	61554	(309) 353-8880
IL	2826	Ratterman, Mark B.	1036 W. Reynolds Street	Pontiac	61764	(815) 317-3300

Exhibit B Traditional
as of December 31, 2023

IL	2827	Vickers, Chad	4323 South Ashland Avenue	Chicago	60609	(773) 254-3030
IL	2828	Ratterman, Mark B.	2255 E. Division Street	Diamond	60416	(815) 324-2525
IL	2830	Ratterman, Mark B.	302 W. Morton Avenue	Jacksonville	62650	(217) 243-7541
IL	2832	Pascucci, Anthony B.	65 S. US Highway 12	Fox Lake	60020	(847) 587-4666
IL	2835	Ratterman, Mark B.	1735 N. Division Street	Morris	60450	(815) 324-4800
IL	2837	Gronemann, James W.	12 W. Dundee Road	Wheeling	60090	(847) 541-7579
IL	2839	Montez, Raymond J.	646 Frontenac Road #103	Aurora	60504	(630) 585-8888
IL	2840	Ratterman, Mark B.	544 W. Jefferson Street	Springfield	62702	(217) 528-2001
IL	2844	Baretz, Douglas W.	2922 N. Main Street	Rockford	61103	(815) 986-3333
IL	2845	Ratterman, Mark B.	106 W. Park Street	Taylorville	62568	(217) 824-4222
IL	2847	Lindeman, Kenneth R.	5531 Belmont Road	Downers Grove	60515	(630) 515-1700
IL	2848	Ratterman, Mark B.	218 S. State Street	Jerseyville	62052	(618) 498-2111
IL	2849	Ratterman, Mark B.	3988 Maryville Road	Granite City	62040	(618) 931-3030
IL	2851	Vickers, Chad	4039 W. 26th Street	Chicago	60623	(773) 277-3166
IL	2852	Badger, Ethan Ray	501 W. 10th Street	Metropolis	62960	(618) 524-5111
IL	2853	Montez, Raymond J.	571 Collins Street	Joliet	60432	(815) 722-3313
IL	2855	Ratterman, Mark B.	4996 State Route 159, Unit C	Maryville	62062	(618) 437-6400
IL	2859	Pascucci, Anthony B.	2208 Richmond Road	McHenry	60051	(815) 331-8668
IL	2861	Montez, Raymond J.	1735 E. Maple Street	Kankakee	60901	(815) 939-4400
IL	2862	Montez, Raymond J.	100 E. John Casey Road	Bourbonnais	60914	(815) 939-6400
IL	2863	Bronzelli, Anthony S.	8538 W. Ogden Avenue	Lyons	60534	(708) 447-9898
IL	2865	Lindeman, Kenneth R.	5912-14 N. Clark Street	Chicago	60660	(773) 769-3030
IL	2869	Lindeman, Kenneth R.	1453 E. Hyde Park Boulevard	Chicago	60615	(773) 324-3800
IL	2871	Hudrick, Robert E.	726-H S. Milwaukee Avenue	Gurnee	60031	(847) 816-7771
IL	2872	Kumar, Kuldeep	3145 South Ashland Avenue	Chicago	60608	(773) 901-4900
IL	2875	Vickers, Chad	2035 E. 95th Street	Chicago	60617	(773) 943-7878
IL	2878	Al-Farah, Ayed T.	4608 W. Fullerton Avenue	Chicago	60639	(773) 772-9000
IL	2879	Al-farah, Eddie	5628 West Fullerton Avenue	Cook	60639	(773) 782-1100
IL	2880	Hudrick, Robert E.	611 West Golf Road	Des Plaines	60016	(224) 404-1400
IL	2881	Gronemann, James W.	1229 North Clybourn Avenue	Chicago	60610	(312) 664-7440
IL	2883	Vickers, Chad	2101 E. 71st Street, Unit C6	Chicago	60649	(773) 757-6700
IL	2886	Gronemann, James W.	1022 Waukegan Road	Northbrook	60062	(847) 205-0025
IL	2887	Hudrick, Robert E.	1828 Sheridan Road	Zion	60099	(847) 746-2000
IL	2888	Montez, Raymond J.	350 Ridge Road	Wilmette	60091	(847) 256-9020
IL	2889	Atallah, Akram	655 E. Sibley Boulevard	Dolton	60419	(708) 841-9490
IL	2891	Hudrick, Robert E.	38973 N. Lewis Avenue	Beach Park	60099	(847) 249-4050
IL	2896	Ratterman, Mark B.	1030 Jason Place	Chatham	62629	(217) 393-6700

Exhibit B Traditional
as of December 31, 2023

IL	2900	Ratterman, Mark B.			407 E. University Avenue, Suite 102	Urbana	61802	(217) 328-6800
IL	2901	Vickers, Chad			8357 South Cottage Grove	Chicago	60619	(877) 883-9643
IL	2902	Duvall, Samuel Edward			1001 Charleston Avenue	Mattoon	61938	(217) 235-7104
IL	2903	Ratterman, Mark B.			2190 Patricia Court	Caseyville	62232	(618) 394-0030
IL	2904	Ratterman, Mark B.			1000 W. Fayette Avenue	Effingham	62401	(217) 347-7788
IL	2905	Ambre, Timothy J.			6942 Kingery Highway (Rt. 83)	Willowbrook	60527	(630) 920-8200
IL	2908	Ambre, Timothy J.			135 N. Randall Road	Batavia	60510	(630) 425-2800
IL	2909	Montez, Raymond J.			2035 S. Washington Street	Naperville	60565	(630) 416-9900
IL	2912	Daugherty, Danny J.			820 S. Park Avenue	Herrin	62948	(618) 988-1686
IL	2915	Burch, Nicholas M.			321 N. Main Street	Benton	62812	(618) 439-9200
IL	2916	Ratterman, Mark B.			1340 W. Main Street	Salem	62881	(618) 548-6600
IL	2918	Mabrey, Jeffrey M.			2501 Broadway	Quincy	62301	(217) 223-4040
IL	2920	Ratterman, Mark B.			520 South Tanner Street	Rantoul	61866	(217) 893-4455
IL	2921	Ratterman, Mark B.			55 E. Green Street	Champaign	61820	(217) 355-0717
IL	2923	Ratterman, Mark B.			1301 N Prospect Road	Champaign	61821	(217) 398-6900
IL	2924	Ratterman, Mark B.			1803 W. Kirby Avenue	Champaign	61821	(217) 398-6800
IL	2926	Reyes, Jair A			229 Barron Boulevard	Grayslake	60030	(847) 223-3300
IL	2929	Ratterman, Mark B.			304 E. Highway 50	O'Fallon	62269	(618) 624-2700
IL	2930	Ratterman, Mark B.			4000 W. Main Street	Belleville	62223	(618) 277-0300
IL	2931	Ratterman, Mark B.			1900 N. Belt East	Belleville	62221	(618) 277-4601
IL	2932	Ratterman, Mark B.			5519 N. Illinois Street	Fairview Heights	62208	(618) 236-2020
IL	2933	Ratterman, Mark B.			1302-1 Camp Jackson Road	Cahokia	62206	(618) 332-2266
IL	2935	Ratterman, Mark B.			9785 Hayden Drive	Mascoutah	62258	(618) 808-0666
IL	2937	Montez, Raymond J.			1148 Douglas Road	Oswego	60543	(630) 554-7777
IL	2940	Ratterman, Mark B.			714 N. Gilbert Street	Danville	61832	(217) 442-4242
IL	2941	Duvall, Samuel Edward			312 E. Main Street	Robinson	62454	(618) 421-4994
IL	2942	Gronemann, James W.			323 W. Irving Park Road	Wood Dale	60191	(630) 860-0111
IL	2945	Baretz, Douglas W.			2545 IL Route 26 South	Freeport	61032	(815) 232-0000
IL	2946	Montez, Raymond J.			3340 Orchard Road, Unit 3340	Oswego	60543	(630) 423-5600
IL	2948	Gronemann, James W.			4707 N. Harlem Avenue	Harwood Heights	60706	(708) 867-4900
IL	2949	Baretz, Douglas W.			1935 Harlem Road	Loves Park	61111	(815) 654-7000
IL	2950	Vosburgh, Lance A.			320 S. Elm	Centralia	62801	(618) 532-0202
IL	2952	Baretz, Douglas W.			3778 E. State Street	Rockford	61108	(815) 398-3333
IL	2953	Ratterman, Mark B.			1501 S. State Route 127, Unit A	Greenville	62246	(618) 664-3033
IL	2954	Ratterman, Mark B.			401 N. State Street	Litchfield	62056	(217) 324-3030
IL	2955	Ratterman, Mark B.			341 W Street Louis Avenue	E. Alton	62024	(618) 254-5000
IL	2956	Ratterman, Mark B.			3310 Godfrey Road	Godfrey	62035	(618) 466-9595

Exhibit B Traditional
as of December 31, 2023

IL	2957	Ratterman, Mark B.	120 E. Vandalia Street	Edwardsville	62025	(618) 692-1515
IL	2958	Ratterman, Mark B.	608 Vandalia Street	Collinsville	62234	(618) 345-8825
IL	2959	Ratterman, Mark B.	2201 Madison Avenue	Granite City	62040	(618) 877-3030
IL	2960	Ratterman, Mark B.	805 Salem Road	Mt Vernon	62864	(618) 244-3030
IL	2961	Arroyave, Mauricio	469-B W. Liberty Street	Wauconda	60084	(847) 526-0550
IL	2962	Arroyave, Mauricio	541 Dundee Avenue	East Dundee	60118	(847) 836-4900
IL	2963	Ratterman, Mark B.	1125 Columbia Center	Columbia	62236	(618) 281-9393
IL	2964	Ratterman, Mark B.	103 Bethalto Drive	Bethalto	62010	(618) 377-3030
IL	2965	Daugherty, Danny J.	44 N. Commercial Street, Suite B	Harrisburg	62946	(618) 252-8311
IL	2966	Emerson, Seth	201 N. Lombard Street	Mahomet	61853	(217) 586-1600
IL	2967	Ratterman, Mark B.	427 Edwardsville Road	Troy	62294	(618) 667-6100
IL	2970	Hemingway, Matthew	5410 South LaGrange Road	Countryside	60525	(708) 580-4900
IL	2971	Ratterman, Mark B.	12545 State Route 143	Highland	62249	(618) 654-7700
IL	2972	Hemingway, Matthew	2411 W. 119th Street	Blue Island	60406	(708) 239-0009
IL	2973	Bronzell, Anthony S.	8841 159th Street	Orland Hills	60487	(708) 460-9900
IL	2974	Arroyave, Mauricio	634 Northwest Highway	Cary	60013	(847) 516-3030
IL	2975	Gronemann, James W.	738 E. Schaumburg Road	Schaumburg	60194	(847) 490-1111
IL	2976	Hemingway, Matthew	10308 South Cicero Avenue	Oak Lawn	60453	(708) 581-9500
IL	2980	Khan, Saad J.	5701 W. Monee Manhattan Road, Unit 105	Monee	60449	(708) 294-8900
IL	2982	Hemingway, Matthew	10260 S. Harlem Avenue	Bridgeview	60455	(708) 233-0700
IL	2983	Gronemann, James W.	10229 W. Grand Avenue	Franklin Park	60131	(847) 737-3400
IL	2984	Hemingway, Matthew	6433 S. Pulaski Avenue	Chicago	60629	(773) 943-7900
IL	2985	Hemingway, Matthew	5401 S. Harlem Avenue	Chicago	60638	(773) 788-1800
IL	2986	Gronemann, James W.	3336 N. Harlem Avenue	Chicago	60634	(773) 622-9600
IL	2987	Khan, Saad J.	4767 Sauk Trail	Richton Park	60471	(708) 481-4780
IL	2989	Emerson, Seth	4 Sage Crossing Boulevard, Suite A	Monticello	61856	(217) 817-5257
IL	2990	Arroyave, Mauricio	3903 W. Algonquin Road	Algonquin	60102	(847) 854-5554
IL	2993	Ambre, Timothy J.	380 W. Galena, Suite B	Aurora	60506	(630) 264-4444
IL	2994	Gronemann, James W.	13850 Brainard Avenue, Bldg. B; Unit A	Burnham	60633	(872) 221-1399
IL	2995	Ratterman, Mark B.	139 Illini Boulevard	Sherman	62684	(217) 480-9191
IL	2996	Burch, Nicholas M.	806 Lehmen Drive	Chester	62233	(618) 826-2020
IL	9160	Gronemann, James W.	1410 Waukegan Road	Glenview	60025	(224) 766-3030
IL	9161	Bohrice, Morice B.	5410 W. Devon Avenue	Chicago	60646	(708) 887-6000
IL	9162	Arroyave, Mauricio	2083 Barrington Road	Hoffman Estates	60169	(847) 908-2100
IL	9163	Arroyave, Mauricio	890 S. Rand Road, Suite C	Lake Zurich	60047	(847) 796-3300
IL	9165	Vickers, Chad	2331-2331B W. Madison Street	Chicago	60612	(312) 600-9121
IL	9166	Vickers, Chad	2508 West Cermak Road	Chicago	60608	(773) 475-6147

Exhibit B Traditional
as of December 31, 2023

IL	9167	Ratterman, Mark B.	207 W. Winters Street, Building No. 1981	Scott AFB	62225	(618) 744-9292
IL	9168	Ambre, Timothy J.	18W333 Roosevelt Road	Lombard	60148	(630) 785-6160
IL	9169	Vickers, Chad	2141 W. 183rd Street	Homewood	60430	(708) 794-4455
IL	9170	Gronemann, James W.	200 W. North Avenue (Route 64)	West Chicago	60185	(630) 520-0606
IL	9174	Burch, Nicholas M.	887 East Grand Avenue	Carbondale	62901	(618) 457-2333
IL	9175	Gronemann, James W.	911 Foster Street	Evanston	60201	(847) 563-3030
IL	9176	Vickers, Chad	45 W. Sauk Trail	South Chicago Heights	60411	(708) 441-3338
IL	9177	Atallah, Akram	14513 Western Avenue	Dixmoor	60426	(708) 577-6100
IL	9178	Bronzelli, Anthony S.	5210 West 159th Street	Oak Forest	60452	(708) 803-8030
IL	9180	Ambre, Timothy J.	360 S. Weber Road	Romeoville	60446	(815) 524-5556
IL	9181	Burch, Nicholas M.	1256 S. Washington	Du Quoin	62832	(618) 790-9300
IL	9182	Vickers, Chad	800 North Kedzie, Unit 108	Chicago	60651	(773) 596-1888
IL	9183	Montez, Raymond J.	636 Deerfield Road, Suite D	Deerfield	60015	(847) 350-7771
IL	9184	Duvall, Samuel Edward	667 Lincoln	Charleston	61920	(217) 345-3030
IL	9185	Aroyave, Mauricio	701 S. Eastwood Drive	Woodstock	60098	(815) 345-3366
IL	9186	Montez, Raymond J.	967 Brookforest Avenue	Shorewood	60404	(779) 234-4200
IL	9187	Atallah, Akram	901 W. Madison	Chicago	60607	(312) 429-4988
IL	9188	Lindeman, Kenneth R.	6607 N. Clark Street	Chicago	60626	(773) 346-3535
IL	9189	Ratterman, Mark B.	113 Radio City Drive	Pekin	61554	(309) 304-7400
IL	9190	Duvall, Samuel Edward	604 Jasper Street	Paris	61944	(217) 712-2033
IL	9191	Ratterman, Mark B.	3100 West Iles Avenue	Springfield	62711	(217) 717-2103
IL	9192	Ratterman, Mark B.	2660 South Fifth Street	Springfield	62703	(217) 717-2104
IL	9193	Gronemann, James W.	2401 Clybourn Avenue	Chicago(clybourn)	60614	(773) 309-0908
IL	9194	Montez, Raymond J.	1224 W. Ogden Avenue, Unit K	Naperville	60563	(630) 687-9001
IL	9195	Burch, Nicholas M.	441 Market Place	Freeburg	62243	(618) 710-0333
IL	9196	Khan, Saad J.	13150 East Lincoln Highway, Suite 5	New Lenox	60451	(815) 242-2020
IL	9197	Ratterman, Mark B.	2278 Washington Road	Washington	61571	(309) 291-3800
IL	9198	Ratterman, Mark B.	10408 N. Centerway Drive, Suite H	Peoria	61615	(309) 282-7878
IL	9685	Ratterman, Mark B.	4115 Broadway Street	Mount Vernon	62864	(618) 816-3433
IN	2191	Ross, Shawn Leighton	7002 Lake Plaza Drive, Suite D	Indianapolis	46220	(463) 237-2080
IN	2501	Harding, Michael	2504 E. 3rd Street	Bloomington	47401	(812) 650-7033
IN	2502	Mueller, Glenn A.	811 W. McCalliard Road	Muncie	47303	(765) 289-3030
IN	2503	Mueller, Glenn A.	989 N. US 31, Suite 4	Whiteland	46184	(317) 751-8001
IN	2504	Mueller, Glenn A.	11640 Brooks School Road, Suite #300	Fishers	46037	(317) 284-7006
IN	2506	Mueller, Glenn A.	206 W. Ireland Road, Units B & C	South Bend	46614	(574) 404-5454
IN	2508	Stegen, Jeffrey	1701 S. Western Avenue	Marion	46953	(765) 664-6060
IN	2510	Stegen, Jeffrey	3606 Cheryl Lane	Lafayette	47909	(765) 767-7900

Exhibit B Traditional
as of December 31, 2023

IN	2511	Stegen, Jeffrey	3961 SR 38 E. Lafayette	Lafayette	47905	(765) 447-9111
IN	2512	Stegen, Jeffrey	2504 Greenbush Street	Lafayette	47904	(765) 743-3000
IN	2513	Schlatter, Christopher	2050 Park Road	Connersville	47331	(765) 222-3015
IN	2514	Stegen, Jeffrey	770 Westfield Road	Noblesville	46062	(317) 773-7373
IN	2515	Stegen, Jeffrey	304 West Walnut Street	Frankfort	46041	(765) 659-3300
IN	2516	Stegen, Jeffrey	950 W. Main Street	Peru	46970	(765) 473-6603
IN	2517	Stegen, Jeffrey	130 South Peru Street	Cicero	46034	(317) 984-7307
IN	2518	Harding, Michael	206 Clifty Drive	Madison	47250	(812) 273-3030
IN	2519	Schlickemeyer, Eric T	2020 N. Lincoln Street	Greensburg	47240	(812) 651-4001
IN	2520	Harding, Michael	914 Eastern Boulevard, Suite 500	Clarksville	47129	(812) 288-4444
IN	2521	Harding, Michael	111 Heritage Square	Sellersburg	47172	(812) 246-6666
IN	2522	Harding, Michael	502 S. Main Street	Salem	47167	(812) 883-6556
IN	2523	Harding, Michael	235 Old Capital Plaza, Suite #2	Corydon	47112	(812) 738-6999
IN	2525	Stegen, Jeffrey	523 N. Lebanon Street	Lebanon	46052	(765) 483-2700
IN	2526	Harding, Michael	748 Highlander Point Drive	Floyds Knobs	47119	(812) 923-9393
IN	2527	Schlickemeyer, Eric T	476 W US Highway 50, Suite C	Versailles	47042	(812) 750-1099
IN	2528	Harding, Michael	1033 Market Street	Charlestown	47111	(812) 256-6600
IN	2529	Mueller, Glenn A.	11805 Allisonville Road	Fishers	46038	(317) 842-3131
IN	2530	Spinney, Shawn J.	955 Wabash Avenue	Terre Haute	47807	(812) 232-8133
IN	2531	Spinney, Shawn J.	3300 N. 25th Street	Terre Haute	47805	(812) 645-7995
IN	2532	Mueller, Glenn A.	1441 S. Guilford Road, Suite 110	Carmel	46032	(317) 846-6100
IN	2533	Mueller, Glenn A.	905 W. Pike Street	Goshen	46526	(574) 349-9340
IN	2534	Spinney, Shawn J.	4408 S. 7th Street	Terre Haute	47802	(812) 299-7171
IN	2535	Mueller, Glenn A.	202 N. Detroit Street	Warsaw	46580	(574) 269-5757
IN	2536	Hurteau, Connor	424 Bloomington	Greencastle	46135	(765) 630-4500
IN	2537	Seagle, Joseph M.	854 State Street	Newburgh	47630	(812) 853-3030
IN	2539	Mueller, Glenn A.	512 High School Drive (aka 8843 S. US 31)	Edinburgh	46124	(812) 526-4000
IN	2540	Mueller, Glenn A.	1770 25th Street	Columbus	47201	(812) 348-6300
IN	2541	Mueller, Glenn A.	1713 N. Morton Street, Suite 10A	Franklin	46131	(317) 738-4455
IN	2542	Mueller, Glenn A.	360 E. Broadway Street	Shelbyville	46176	(317) 398-0724
IN	2543	Mueller, Glenn A.	1827 E. 18th Street	Anderson	46016	(765) 644-2900
IN	2544	Mueller, Glenn A.	1211 N. Madison Avenue	Greenwood	46142	(317) 859-3030
IN	2545	Harding, Michael	5560 State Road 46	Bloomington	47404	(812) 650-5099
IN	2546	Mueller, Glenn A.	2235 E. Main Street	Plainfield	46168	(317) 839-3966
IN	2547	Mueller, Glenn A.	4979 W. Smith Valley Road	Greenwood	46142	(317) 881-3030
IN	2548	Frias, Marlon Rafael	5999 Crawfordsville Road	Speedway	46224	(463) 800-4830
IN	2549	Harding, Michael	1605 M Street	Bedford	47421	(812) 508-8484

Exhibit B Traditional
as of December 31, 2023

IN	2550	Schlater, Christopher	401 National Road West	Richmond	47374	(765) 966-8351
IN	2551	Schlater, Christopher	3631 E. National Road	Richmond	47374	(765) 200-7000
IN	2552	Schlater, Christopher	609 South Memorial Drive	New Castle	47362	(765) 388-5500
IN	2554	Mueller, Glenn A.	11135 Pendleton Pike, Suite 50	Indianapolis	46269	(317) 823-0030
IN	2555	Mueller, Glenn A.	843 N. Capitol Avenue	Indianapolis	46204	(317) 635-3030
IN	2556	Harding, Michael	2620 S. Walnut Street	Bloomington	47401	(812) 335-7777
IN	2557	Harding, Michael	908 N. Walnut Street	Bloomington	47401	(812) 334-3030
IN	2558	Frias, Marlon Rafael	4070 Pendleton Way	Indianapolis	46226	(317) 547-3030
IN	2559	Norris, Maxwell Mark	5917 E. 82nd Street	Indianapolis	46250	(317) 578-3030
IN	2560	Mueller, Glenn A.	9935 E. 21st Street	Indianapolis	46229	(317) 899-3030
IN	2561	Harding, Michael	811 Talaina Place	New Albany	47150	(812) 913-7800
IN	2562	Mueller, Glenn A.	5603 N. Michigan Road	Indianapolis	46228	(463) 237-2031
IN	2563	Frias, Marlon Rafael	3851 Moller Road	Indianapolis	46254	(317) 299-3030
IN	2564	Mueller, Glenn A.	1350 W. Southport Road, Suite F	Indianapolis	46217	(317) 865-0330
IN	2565	Mueller, Glenn A.	985 N. Shadeland Avenue	Indianapolis	46219	(317) 357-3030
IN	2566	Mueller, Glenn A.	4030 S. Emerson Avenue	Indianapolis	46203	(317) 783-3030
IN	2567	Mueller, Glenn A.	4545 Rockville Road	Indianapolis	46222	(317) 240-3030
IN	2568	Mueller, Glenn A.	3220 S. East Street	Indianapolis	46227	(317) 784-7755
IN	2569	Frias, Marlon Rafael	2522 E. Washington Street	Indianapolis	46201	(317) 636-0900
IN	2570	Seagle, Joseph M.	600 N. Weinbach Avenue	Evansville	44711	(812) 473-1011
IN	2571	Seagle, Joseph M.	1300 S. Green River Road	Evansville	47715	(812) 477-5544
IN	2573	Seagle, Joseph M.	2619 N. 6th Street	Vincennes	47591	(812) 886-4200
IN	2574	Seagle, Joseph M.	5714 N. 1st Street Avenue	Evansville	47710	(812) 423-5511
IN	2575	Mueller, Glenn A.	5801 North Green Street, Suite 107	Brownsburg	46112	(317) 852-6222
IN	2576	Gronemann, James W.	8905 Indianapolis, Unit A	Highland	46322	(219) 595-8100
IN	2577	Seagle, Joseph M.	421-B North Street Joseph Avenue	Evansville	47712	(812) 424-7333
IN	2578	Seagle, Joseph M.	2101 S. Weinbach Avenue	Evansville	47714	(812) 473-3383
IN	2579	Mueller, Glenn A.	7810 E. US 36, Suite A	Avon	46123	(317) 272-3050
IN	2580	Harding, Michael	1710 E Tenth Street	Jeffersonville	47130	(812) 284-0300
IN	2581	Harding, Michael	2613 Charlestown Road	New Albany	47150	(812) 944-0030
IN	2582	Harding, Michael	1104 E. Tipton	Seymour	47274	(812) 523-3959
IN	2583	Davey, Matthew Robert	1103 US Highway 50 W.	Lawrenceburg	47025	(812) 537-0006
IN	2584	Gronemann, James W.	51160 Bittersweet #1A	Granger	46530	(574) 271-8885
IN	2585	Seagle, Joseph M.	1940 N. Green River Road	Evansville	47715	(812) 471-8585
IN	2586	Harding, Michael	2784 Meijer Drive, Suite 1A	Jeffersonville	47130	(812) 913-0031
IN	2587	Gronemann, James W.	30830 OLD US-20	Elkhart	36514	(574) 621-3330
IN	2588	Gronemann, James W.	920 S. Merrifield Avenue	Mishawaka	46544	(574) 257-1700

Exhibit B Traditional
as of December 31, 2023

IN	2589	Duvall, Samuel Edward	1004 East 4th Street	Mt. Vernon	47620	(812) 838-3003
IN	2590	Duvall, Samuel Edward	410 US 231 S.	Jasper	47546	(812) 634-9897
IN	2592	Duvall, Samuel Edward	418 E. National Highway	Washington	47501	(812) 698-5550
IN	2601	Schlickemeyer, Eric T	14 Alpine Drive	Batesville	47006	(812) 717-3555
IN	2602	Gronemann, James W.	5374 Broadway	Merrillville	46410	(219) 884-0114
IN	2603	Gronemann, James W.	1895 Crisman Road, Suite C	Portage	46383	(219) 706-7010
IN	2604	Gronemann, James W.	1918 165th Street, Suite 700	Hammond	46320	(219) 989-6550
IN	2605	Schlickemeyer, Eric T	1220 W. McClain Avenue, Suite 100	Scottsburg	47170	(812) 722-4001
IN	2606	Stegen, Jeffrey	711 E. Main Street	Westfield	46074	(317) 896-9292
IN	2608	Stegen, Jeffrey	3504-A Paramount Drive	West Lafayette	47906	(765) 497-4992
IN	2610	Gronemann, James W.	5780 Franklin Street	Michigan City	46360	(219) 809-2300
IN	2618	Gronemann, James W.	1682 E Commercial Avenue	Lowell	46356	(219) 225-6930
IN	2619	Gronemann, James W.	560 Indian Boundary Road, Unit 1	Chesterton	46304	(219) 250-3068
IN	2620	Gronemann, James W.	7444 Kennedy Avenue	Hammond	46323	(219) 844-2555
IN	2621	Gronemann, James W.	135 N. Wisconsin Street	Hobart	46342	(219) 973-4040
IN	2622	Gronemann, James W.	2316 Franklin Street	Michigan City	46360	(219) 879-8330
IN	2624	Gronemann, James W.	1494 N. Main Street	Crown Point	46307	(219) 662-0313
IN	2625	Gronemann, James W.	1707 LaPorte Avenue	Valparaiso	46383	(219) 465-5500
IN	2626	Schlickemeyer, Eric T	610 IN-39 Bypass S	Martinsville	46151	(765) 343-4449
IN	2630	Stegen, Jeffrey	2816 S. Washington	Kokomo	46902	(765) 453-9111
IN	2631	Stegen, Jeffrey	2304 W. Sycamore	Kokomo	46901	(765) 456-3891
IN	2634	Reiniche, Jeffrey R.	1500 N. Wayne Street, Suite A-1	Angola	46703	(260) 665-3880
IN	2638	Mayhall, Dennis L.	1532 W. Cook Road	Fort Wayne	46825	(260) 702-9600
IN	2639	Mayhall, Dennis L.	1020 E. Tillman Road	Fort Wayne	46816	(260) 247-6560
IN	2644	Mayhall, Dennis L.	10420 Maysville Road	Fort Wayne	46835	(260) 245-2525
IN	2646	Gronemann, James W.	841 Main Street	Munster	46321	(219) 315-0350
IN	2647	Gronemann, James W.	7758 S. Broadway	Merrillville	46410	(219) 576-6022
IN	2648	Fendel, Vincent L.	320 Broadway Street	New Haven	46774	(260) 749-9999
IN	2650	Gronemann, James W.	1528 Arbogast	Griffith	46319	(219) 809-2300
IN	2653	Stegen, Jeffrey	2800 Wal Mart Drive	Huntington	46750	(260) 355-7575
IN	2654	Mueller, Glenn A.	1627 Edison Road	South Bend	46637	(574) 271-0300
IN	2657	Stegen, Jeffrey	1307 North Cass Street	Wabash	46992	(260) 377-4500
IN	2658	Mayhall, Dennis L.	2910 East Dupont Road	Fort Wayne	46825	(260) 999-4186
IN	2659	Mueller, Glenn A.	1202 N. State Street	Greenfield	46140	(317) 318-1879
IN	2660	Frias, Marlon Rafael	7411 North Keystone Avenue	Indianapolis	46240	(317) 257-5644
IN	2661	Frias, Marlon Rafael	501 E. 38th Street	Indianapolis	46205	(317) 924-3030
IN	2663	Mueller, Glenn A.	4015 E. Southport Road, Suite C	Indianapolis	46237	(463) 237-2170

Exhibit B Traditional
as of December 31, 2023

IN	2664	Frias, Marlon Rafael	7875 W. 10th Street	Indianapolis	46214	(317) 271-0413
IN	2665	Mueller, Glenn A.	4430 Mann Road	Indianapolis	46221	(317) 856-3331
IN	2666	Mueller, Glenn A.	8403 N. Michigan Road, Suite A	Indianapolis	46268	(317) 876-3030
IN	2668	Schlickemeyer, Eric T	529 North Section Street, Suite 2	Sullivan	47882	(812) 268-3300
IN	2670	Stegen, Jeffrey	3423 E. Market Street	Logansport	46947	(574) 753-6305
IN	2671	Hurteau, Connor	324 E. National Avenue	Brazil	47834	(812) 420-5011
IN	2672	Mayhall, Dennis L.	1920 North Coliseum Boulevard	Fort Wayne	46805	(260) 267-9617
IN	2673	Mayhall, Dennis L.	301 W. Jefferson Boulevard, Suite 135	Fort Wayne	46802	(260) 444-4560
IN	2674	Mayhall, Dennis L.	4818 Illinois Road	Fort Wayne	46804	(260) 203-3016
IN	2675	Hurteau, Connor	1500 W. Washington Street	Crawfordsville	47933	(765) 307-4047
IN	2680	Schlickemeyer, Eric T	1601 N. Main Street	Rushville	46173	(877) 883-9643
IN	9670	Gronemann, James W.	6036 US-6	Portage	46368	(219) 841-6030
IN	9671	Mueller, Glenn A.	3301 Lincoln Way West	South Bend	46628	(574) 703-3638
IN	9672	Gronemann, James W.	325 J Street	La Porte	46350	(219) 380-0760
IN	9673	Gronemann, James W.	218 W. Lincoln Highway	Schererville	46375	(219) 323-8550
IN	9674	Stegen, Jeffrey	616 West Stadium Avenue	West Lafayette	47906	(765) 497-7890
KS	1692	Cunningham, Donal	321 S. Andover Road, Suite 500	Andover	67002	(316) 351-5882
KS	1693	Cunningham, Donal	4734 S. Broadway Street	Wichita	67216	(316) 295-4752
KS	6301	Schweitzer, Michael H.	14319 W. 135th Street	Olathe	66062	(913) 308-3030
KS	6302	Minor, Jacob Albert	832 Iowa Street	Lawrence	66044	(785) 841-8002
KS	6305	Green, Troy A.	2940 SW Wanamaker Road, Suite 108	Topeka	66614	(785) 232-3600
KS	6306	Green, Troy A.	735 SW Topeka Boulevard	Topeka	66603	(785) 232-2300
KS	6307	Green, Troy A.	2835 SE California Avenue	Topeka	66605	(785) 267-6400
KS	6311	Cunningham, Donal	2020 Tuttle Creek Boulevard	Manhattan	66502	(785) 776-7788
KS	6314	Elwell, Emily E.	1422 S. Santa Fe Avenue	Chanute	66720	(620) 305-4010
KS	6315	Cunningham, Donal	1621 S. Ohio Street	Salina	67401	(785) 825-7788
KS	6316	Cunningham, Donal	603 W. 6th Street	Junction City	66441	(785) 762-2500
KS	6321	Cunningham, Donal	2330 Ohio Street, Suite #100	Augusta	67010	(316) 247-9247
KS	6325	Friedman, Shawn C.	3703 10th Street	Great Bend	67530	(620) 400-5030
KS	6328	Green, Troy A.	937 E. Lincoln Lane	Gardner	66030	(913) 884-7200
KS	6340	Schweitzer, Michael H.	705 E. Santa Fe Street	Olathe	66061	(913) 764-6311
KS	6341	Schweitzer, Michael H.	5435 Johnson Drive	Mission	66205	(913) 387-4054
KS	6343	Schweitzer, Michael H.	22231 W. 66th Street	Shawnee	66226	(913) 422-9494
KS	6345	Schweitzer, Michael H.	11036 Quivira Road	Overland Park	66210	(913) 894-4144
KS	6346	Cunningham, Donal	2100 N. Rock Road, Suite 600	Derby	67037	(316) 295-2829
KS	6347	Cunningham, Donal	1720 Main Street	Winfield	67156	(620) 301-1500
KS	6350	Cunningham, Donal	2417 A South Seneca Street	Wichita	67217	(316) 260-1105

Exhibit B Traditional
as of December 31, 2023

KS	6351	Schweitzer, Michael H.			5227 W. 95th Street	Overland Park	66207	(913) 341-6884
KS	6360	Miller, Daryl M.			821 S. 5th Street	Leavenworth	66048	(913) 651-7244
KS	6361	Dixon, Katherine A			1610 S. Main Street	Ottawa	66067	(785) 893-6336
KS	6364	Cunningham, Donal			7840 Normandy Drive	Fort Riley	66442	(785) 761-2700
KS	6375	Friedman, Shawn C.			2047 W. 21st Street N	Wichita	67203	(316) 260-8727
KS	6376	Cunningham, Donal			3750 N. Woodlawn	Wichita	67220	(316) 201-6191
KS	6377	Friedman, Shawn C.			7130 W. Maple Street, Suite 130	Wichita	67209	(316) 816-2200
KS	6380	Elwell, Emily E.			100 N 25th	Independence	67301	(620) 577-6060
KS	6385	Friedman, Shawn C.			2505 Vine Street	Hays	67601	(785) 625-2311
KS	6387	Friedman, Shawn C.			10231 W. 21st Street N, #101 A	Wichita	67205	(316) 773-6868
KS	6388	Friedman, Shawn C.			327 N. Hillside Street	Wichita	67214	(316) 351-5525
KS	6391	Cunningham, Donal			583 S. West Street	Wichita	67213	(316) 500-7077
KS	6392	Cunningham, Donal			7825 East Harry Street, Suite 209	Wichita	67207	(316) 683-3131
KS	6393	Lessert, Kelly Wade			2205-A Central Avenue	Dodge City	67801	(620) 371-5498
KS	6394	Friedman, Shawn C.			2500 North Main Street, Suite A	Hutchinson	67502	(620) 259-7585
KS	6399	Minor, Jacob Albert			15630 Pinehurst Drive, Suite 8	Basehor	66007	(913) 662-7878
KS	9630	Elwell, Emily E.			716 S. Broadway	Pittsburg	66762	(620) 231-5555
KS	9631	Cunningham, Donal			640 Huebner Road	Fl. Riley	66442	(785) 761-2480
KS	9632	Minor, Jacob Albert			1008 West 23rd Street	Lawrence	66046	(785) 856-2510
KS	9633	Minor, Jacob Albert			8055 State Avenue	Kansas City	66112	(913) 766-2333
KS	9634	Green, Troy A.			2326 Industrial Road	Emporia	66801	(620) 341-9411
KS	9635	Cunningham, Donal			2401 N. Summit Street, Suite G	Arkansas City	67005	(620) 307-5998
KS	9636	Cunningham, Donal			2422 W. Central Avenue, Suite 100	El Dorado	67042	(316) 320-3533
KS	9637	Cunningham, Donal			1400 S. Kansas Avenue, Suite 1400	Newton	67114	(316) 282-3434
KS	9638	Claassen, Grant Daniel			719 North Main Street	McPherson	67460	(620) 504-6050
KS	9639	Elwell, Emily E.			2 Jersey Street	Fort Scott	66701	(620) 768-5533
KS	9640	Lessert, Kelly Wade			2312 E. Kansas Avenue, Suite C	Garden City	67846	(620) 277-7096
KS	9641	Lessert, Kelly Wade			1580 N. Kansas Avenue	Liberal	67901	(620) 624-2299
KS	9642	Elwell, Emily E.			2101 Main Street	Parsons	67357	(620) 820-2244
KY	1359	Reisch, Christian J.			125 Towne Center Drive, Suite 127	Lexington	40511	(859) 300-6464
KY	1365	Davey, Matthew Robert			167 Winning Colors Way	Walton	41094	(859) 485-0700
KY	1366	Harding, Michael			544 Conestoga Parkway #15	Shepherdsville	40165	(502) 543-1212
KY	1367	Davey, Matthew Robert			6424 Taylor Mill Road, Suites 2&3	Independence	41051	(859) 363-2800
KY	1369	Harding, Michael			757 By-Pass Road	Brandenburg	40108	(270) 422-4230
KY	1370	Davey, Matthew Robert			2575 North Bend Road	Hebron	41048	(859) 689-6444
KY	1371	Lawson, Robert D.			1351 N. Main Street	Beaver Dam	42320	(270) 363-2218
KY	1373	Reisch, Christian J.			15 Grandview Drive	Frankfort	40601	(502) 695-1558

Exhibit B Traditional
as of December 31, 2023

KY	1374	Harding, Michael	6434 North Preston Highway, #4	Hillview	40229	(502) 955-4444
KY	1375	Davey, Matthew Robert	1785 Patrick Drive	Burlington	41005	(859) 586-0444
KY	1376	Reisch, Christian J.	102 Plaza Drive	Lawrenceburg	40342	(502) 839-8800
KY	1377	Short, Christopher J.	22 Frontier Boulevard	Stanford	40484	(606) 365-1818
KY	1378	Cartigan, Benjamin Eli	213 East Main Street	Scottsville	42164	(270) 237-5555
KY	1380	Seagle, Joseph M.	4709 Scottsville Road	Bowling Green	42104	(270) 781-1000
KY	1381	Lawson, Robert D.	30 Shelton Lane	Russellville	42276	(270) 726-1500
KY	1382	Razban, Ahmad	31 Carroll Road, Suite B	Benton	42025	(270) 527-1030
KY	1383	Averill, Kurt	503 US Highway 45, Suite B	Fulton	42041	(270) 472-3000
KY	1384	Thompson, Timothy K. Jr.	6332 W. Highway 146, #2	Crestwood	40014	(502) 241-0600
KY	1385	Thompson, Timothy K. Jr.	9551 US Highway 42	Prospect	40059	(502) 228-3030
KY	1386	Razban, Ahmad	2720 New Holt Road, Suite A	Paducah	42001	(270) 575-0100
KY	1389	Lawson, Robert D.	605 W. Everly Bros. Boulevard	Central City	42330	(270) 757-9300
KY	1390	Thompson, Timothy K. Jr.	310 South 1st Street, Suite A	La Grange	40031	(502) 222-2202
KY	1391	Harding, Michael	110 Oakbrooke Drive	Mount Washington	40047	(502) 538-3888
KY	1394	Reisch, Christian J.	3090 Helmsdale Place, Suite #300	Lexington	40509	(859) 543-1999
KY	1401	Reisch, Christian J.	1150 US Highway 127 South	Frankfort	40601	(502) 385-2530
KY	1402	Reisch, Christian J.	828 Lane Allen Road, Unit #26	Lexington	40504	(859) 276-4440
KY	1403	Reisch, Christian J.	103 Village Market Path	Georgetown	40324	(502) 735-0030
KY	1404	Reisch, Christian J.	460 Lexington Road	Versailles	40383	(859) 214-7900
KY	1405	Reisch, Christian J.	3120 Pimlico Parkway, Suite 116	Lexington	40517	(859) 273-1515
KY	1406	Reisch, Christian J.	130 W. Tiverton Way #150	Lexington	40503	(859) 273-4626
KY	1407	Bouvin, Carey J.	3101 Clays Mill Road	Lexington	40503	(859) 223-1540
KY	1408	Reisch, Christian J.	801 Euclid Avenue	Lexington	40502	(859) 269-3030
KY	1409	Short, Christopher J.	800 S. Main Street, Suite D	Nicholasville	40356	(859) 885-6061
KY	1410	Short, Christopher J.	1232 N. 12th Street	Middlesboro	40965	(606) 658-9888
KY	1413	Harding, Michael	1039 West Main	Shelbyville	40065	(502) 633-0606
KY	1414	Reisch, Christian J.	328 Eastern Bypass	Richmond	40475	(859) 623-0030
KY	1415	Williams, Joseph M.	135 E. Main Street, Suite 1	Danville	40422	(859) 236-2900
KY	1416	Short, Christopher J.	155 Pine Crest Road	Morehead	40351	(606) 783-0030
KY	1417	Davey, Matthew Robert	4387 Winston Avenue	Covington	41015	(859) 655-9999
KY	1418	Reisch, Christian J.	1102 Lexington Road	Georgetown	40324	(502) 863-6100
KY	1419	Williams, Joseph M.	451 S. College Street	Harrodsburg	40330	(859) 605-8090
KY	1420	Murph, Alan D.	4190 Morgan Road	Ft. Campbell	42223	(270) 697-1122
KY	1421	Ratterman, Mark B.	2520 Bardstown Road	Louisville	40205	(502) 458-0030
KY	1422	Ratterman, Mark B.	3951 Taylorsville Road	Louisville	40220	(502) 458-0300
KY	1423	Ratterman, Mark B.	2400 Brownsboro Road	Louisville	40206	(502) 895-3030

Exhibit B Traditional
as of December 31, 2023

KY	1424	Ratterman, Mark B.			812 Eastern Parkway	Louisville	40217	(502) 637-3030
KY	1425	Thompson, Timothy K. Jr.			9407 Westport Road, Suite 101	Louisville	40241	(502) 425-5170
KY	1426	Ratterman, Mark B.			3900 7th Street Road	Louisville	40216	(502) 449-3030
KY	1427	Ratterman, Mark B.			8404 Preston Highway	Louisville	40219	(502) 966-3030
KY	1428	Ratterman, Mark B.			130 Breckinridge Lane	Louisville	40207	(502) 897-3030
KY	1429	Ratterman, Mark B.			11517 Shelbyville Road	Louisville	40243	(502) 245-3030
KY	1430	Thompson, Timothy K. Jr.			10000 Brownsboro Road	Louisville	40241	(502) 409-4096
KY	1431	Ratterman, Mark B.			10011 Dixie Highway	Louisville	40272	(502) 935-3030
KY	1432	Ratterman, Mark B.			6803 Southside Drive	Louisville	40214	(502) 363-3030
KY	1433	Ratterman, Mark B.			5400 Preston Highway	Louisville	40213	(502) 966-3000
KY	1434	Thompson, Timothy K. Jr.			8054-A New LaGrange Road, Suite A	Louisville	40222	(502) 423-0030
KY	1435	Ratterman, Mark B.			7924 Fegenbush Lane	Louisville	40228	(502) 239-0300
KY	1436	Ratterman, Mark B.			5219 Dixie Highway	Louisville	40216	(502) 449-3000
KY	1437	Seagle, Joseph M.			701 N. 3rd Street	Bardstown	40004	(502) 348-1274
KY	1438	Short, Christopher J.			104 London Shopping Center	London	40741	(606) 877-3030
KY	1440	Reisch, Christian J.			524 West New Circle Road, Suite 180	Lexington	40511	(859) 233-3030
KY	1441	Short, Christopher J.			920 Indian Mound Drive	Mount Sterling	40353	(859) 279-2700
KY	1444	Davey, Matthew Robert			102 Pavilion Parkway	Newport	41071	(859) 781-3311
KY	1445	Short, Christopher J.			119 Clay Drive	Berea	40403	(859) 986-7445
KY	1446	Rigsby, James S.			716 E. Broadway Street	Campbellsville	42718	(270) 789-1115
KY	1447	Williams, Joseph M.			1740 S. Main Street	Paris	40361	(859) 987-0080
KY	1449	Williams, Joseph M.			200 Codella Drive	Winchester	40391	(859) 745-0800
KY	1450	Seagle, Joseph M.			651 South Wilson Road	Radcliff	40160	(270) 351-2121
KY	1451	Seagle, Joseph M.			675 Knox Boulevard	Radcliff	40160	(270) 351-6091
KY	1452	Seagle, Joseph M.			603 N Miles Street	Elizabethtown	42701	(270) 769-5901
KY	1453	Seagle, Joseph M.			650 US 31-W Bypass	Bowling Green	42101	(270) 781-6063
KY	1454	Seagle, Joseph M.			2201-A Stonehenge Avenue	Bowling Green	42101	(270) 781-9494
KY	1455	Seagle, Joseph M.			1003 Burlew Boulevard	Owensboro	42303	(270) 683-8777
KY	1456	Seagle, Joseph M.			3333 Frederica Drive	Owensboro	42301	(270) 926-6400
KY	1457	Seagle, Joseph M.			304 S Main Street	Madisonville	42431	(270) 825-1010
KY	1458	Seagle, Joseph M.			700 Second Street	Henderson	42420	(270) 826-7888
KY	1459	Davey, Matthew Robert			9031 US Highway 42, Suite B	Union	41091	(859) 384-6630
KY	1460	Seagle, Joseph M.			810 W Cherry Street	Glasgow	42141	(270) 651-2404
KY	1461	Davey, Matthew Robert			102 Elm Street	Ludlow	41016	(859) 669-2900
KY	1462	Davey, Matthew Robert			7647 Alexandria Pike	Alexandria	41001	(859) 448-2600
KY	1464	Ratterman, Mark B.			3830 Ruckriegal Parkway, Suite 101	Louisville	40299	(502) 267-3030
KY	1465	Short, Christopher J.			1886 S. Highway 27	Somerset	42501	(606) 679-7472

Exhibit B Traditional
as of December 31, 2023

KY	1466	Short, Christopher J.	1215 N. Main Street, Suite 15	Monticello	42633	(606) 348-3377
KY	1470	Hurd, Timothy A.	115 Pike Street	Pikeville	41501	(606) 432-1133
KY	1471	Davey, Matthew Robert	7550 Dixie Highway	Florence	41042	(859) 371-8500
KY	1474	Short, Christopher J.	1504 Cumberland Falls Highway, Suite 1	Corbin	40701	(606) 528-0414
KY	1479	Short, Christopher J.	937 Highway 25W	Williamsburg	40769	(606) 549-3060
KY	1480	Graves, Susan L.	1243 Carter Avenue	Ashland	41101	(606) 325-7777
KY	1483	Davey, Matthew Robert	2353 Buttermilk Crossing	Crescent Springs	41017	(859) 331-4040
KY	1485	Maiberger, Greg	114 E Second Street	Maysville	41056	(606) 564-6782
KY	1487	Razban, Ahmad	3240 Lone Oak Road	Paducah	42003	(270) 554-0080
KY	1488	Razban, Ahmad	3831 Clarks River Road	Paducah	42003	(270) 444-0080
KY	1489	Razban, Ahmad	2900 Jackson Street	Paducah	42003	(270) 442-9119
KY	1491	Seagle, Joseph M.	2211 Fort Campbell Boulevard	Hopkinsville	42240	(270) 885-2233
KY	1492	Razban, Ahmad	603 W. Broadway	Mayfield	42066	(270) 247-3366
KY	1494	Lawson, Robert D.	1309 Elizabethtown Road	Leitchfield	42754	(270) 971-1805
KY	1495	Wilson, Joseph Scott	90 S. Main Street, Suite 1A	Dry Ridge	41035	(859) 823-1234
KY	1496	Razban, Ahmad	110 S. 12th Street	Murray	42071	(270) 753-3030
KY	2159	Davey, Matthew Robert	160 Barnwood Drive	Edgewood	41017	(859) 331-3500
KY	5436	Carrigan, Benjamin Eli	520 Main Street, Suite A	Franklin	42134	(270) 776-9696
LA	3007	Mueller, Glenn A.	33716 LA Highway 16, Suite E	Denham Springs	70706	(225) 664-3015
LA	3011	Carpenter, Penne L.	16646 W. Main Street	Cutoff	70345	(985) 325-3030
LA	3012	Mueller, Glenn A.	8202 Maurice Avenue	Maurice	70555	(337) 893-4334
LA	3016	Mueller, Glenn A.	570 West Pine Street	Ponchatoula	70454	(985) 370-0039
LA	3027	Mueller, Glenn A.	201 W. Gloria Switch Road, Unit 1	Lafayette	70507	(337) 886-0030
LA	3031	Mueller, Glenn A.	17278 Airline Highway, Ste #A	Prairieville	70769	(225) 744-3232
LA	3032	Mueller, Glenn A.	6025 U.S. Highway 90 East	Broussard	70518	(337) 839-3660
LA	3036	Mueller, Glenn A.	1880 Rees Street, Suite 203-B	Breaux Bridge	70517	(337) 332-0323
LA	3037	Mueller, Glenn A.	28470 Walker Road South	Walker	70785	(225) 664-3090
LA	3038	Mueller, Glenn A.	68228 Highway 59, Suite A	Mandeville	70471	(985) 809-0003
LA	3043	Mueller, Glenn A.	36508 Event Road, Suite A	Geismar	70734	(225) 332-0772
LA	3044	Mueller, Glenn A.	70380 LA-21, Suite 10	Covington	70433	(985) 875-7743
LA	3045	Mueller, Glenn A.	3225 LA Highway 1 South, Suite B	Port Allen	70767	(225) 377-2020
LA	3046	Mueller, Glenn A.	8530 Youree Drive	Shreveport	71115	(318) 795-2380
LA	3047	Mueller, Glenn A.	1616 Veterans Memorial Drive, Suite 3	Erath	70533	(337) 685-3030
LA	3048	Mueller, Glenn A.	5761 W. Park Avenue	Houma	70364	(985) 223-3030
LA	3053	Tucker, Freddie	126 Rowland Road	Monroe	71203	(318) 343-4984
LA	3054	Fain, John Dwayne	4455 Pines Road	Shreveport	71129	(318) 688-3030
LA	3055	Mueller, Glenn A.	1955 Ormond Boulevard, Suite K	Destrehan	70047	(985) 764-8751

Exhibit B Traditional
as of December 31, 2023

LA	3057	Mueller, Glenn A.	2170 Gause Boulevard West, Suite 177	Slidell	70460	(985) 649-3030
LA	3058	Magee, Gregory S.	201 Superior Avenue	Bogalusa	70427	(985) 732-5551
LA	3059	Mueller, Glenn A.	1000 E. Highway 80, Suite A	Haughton	71037	(318) 949-2000
LA	3061	Varela, Mario	937 Creswell Lane	Opelousas	70570	(337) 942-3334
LA	3062	Mueller, Glenn A.	1720 Lake Avenue	Metairie	70005	(504) 832-2877
LA	3063	Patrick, Joseph Harold	8910 Greenwell Springs Road	Baton Rouge	70814	(225) 231-2690
LA	3064	Mueller, Glenn A.	204 Sam Houston Parkway	Lake Charles	70611	(337) 855-8100
LA	3065	Mueller, Glenn A.	2300 Maplewood Drive	Sulphur	70663	(337) 626-2070
LA	5200	Mueller, Glenn A.	13505 Highway 90, Suite B	Boutee	70039	(985) 785-1200
LA	5201	Mueller, Glenn A.	4938 Freret Street	New Orleans	70115	(504) 891-3030
LA	5202	Mueller, Glenn A.	651 Terry Parkway, Suite 101	Gretna	70056	(504) 366-5300
LA	5204	Mueller, Glenn A.	2032 Manhattan Boulevard	Harvey	70058	(504) 366-3030
LA	5205	Mueller, Glenn A.	2405 David Drive	Metairie	70003	(504) 885-3030
LA	5207	Mueller, Glenn A.	4308 Williams Boulevard	Kenner	70065	(504) 949-0900
LA	5208	Mueller, Glenn A.	3030 Severn Avenue Bay #10	Metairie	70002	(504) 885-2667
LA	5209	Mueller, Glenn A.	1092 Westbank Expressway	Westwego	70094	(504) 348-1800
LA	5210	Mueller, Glenn A.	4855 General Meyer Avenue	New Orleans	70131	(504) 394-4653
LA	5211	Mueller, Glenn A.	2325 1/2 Metairie Road	Metairie	70001	(504) 834-3030
LA	5212	Mueller, Glenn A.	402 North Carrollton Avenue	New Orleans	70119	(504) 483-7770
LA	5213	Mueller, Glenn A.	3737 Jefferson Highway	Jefferson	70121	(504) 832-3030
LA	5214	Mueller, Glenn A.	9837 Bluebonnet Boulevard	Baton Rouge	70810	(225) 236-3030
LA	5215	Mueller, Glenn A.	10544 Sullivan Road, Suite A	Central	70818	(225) 261-9691
LA	5217	Mueller, Glenn A.	875 Robert Road	Slidell	70458	(985) 641-3030
LA	5218	Mueller, Glenn A.	550 Old Spanish Trail	Slidell	70458	(985) 646-1311
LA	5219	Mueller, Glenn A.	316 E. Judge Perez Drive	Chalmette	70043	(504) 279-3010
LA	5223	Mueller, Glenn A.	10500 Chef Menteur Highway	New Orleans	70127	(504) 240-6700
LA	5224	King, Shameka	3931 Downman Road	New Orleans	70126	(504) 246-3030
LA	5225	Parnell, Rysean	135 Carondelet Street	New Orleans	70130	(504) 525-3663
LA	5226	Mueller, Glenn A.	3676 Harding Boulevard, Suite D	Baton Rouge	70807	(225) 775-3278
LA	5228	Mueller, Glenn A.	5050 W Esplanade #J	Metairie	70006	(504) 885-7101
LA	5230	Mueller, Glenn A.	345 W. Esplanade	Kenner	70065	(504) 466-3030
LA	5232	Mueller, Glenn A.	10601 Jefferson Highway	River Ridge	70123	(504) 738-3161
LA	5233	Mueller, Glenn A.	2466 Barataria Boulevard	Marrero	70072	(504) 349-4600
LA	5235	Parnell, Rysean	1701 Tchoupitoulas	New Orleans	70130	(504) 523-3030
LA	5236	Parnell, Rysean	1120 Franklin Avenue	New Orleans	70117	(504) 948-3030
LA	5237	Mueller, Glenn A.	103 W. Airline Highway	La Place	70068	(985) 651-2772
LA	5238	Mueller, Glenn A.	7580 Highway 23	Belle Chasse	70037	(504) 392-9500

Exhibit B Traditional
as of December 31, 2023

LA	5239	Mueller, Glenn A.		1829 N. Airline Highway	Gonzales	70737	(225) 647-9442
LA	5240	Mueller, Glenn A.		1413 Tunnel Boulevard	Houma	70360	(985) 876-3030
LA	5241	Mueller, Glenn A.		615 Grand Caillou Road	Houma	70363	(985) 851-0151
LA	5242	Mueller, Glenn A.		6402 Highway 182 E.	Morgan City	70380	(985) 384-3030
LA	5243	Mueller, Glenn A.		247 West Park Avenue	Thibodaux	70301	(985) 448-1700
LA	5244	Mueller, Glenn A.		803 Collins Boulevard	Covington	70433	(985) 892-2992
LA	5245	Mueller, Glenn A.		3845 Highway 22 #3	Mandeville	70471	(985) 626-1300
LA	5246	Mueller, Glenn A.		1400 W. Thomas Street	Hammond	70401	(985) 542-7284
LA	5247	Mueller, Glenn A.		14 N. N. Lewis Street	New Iberia	70560	(337) 365-3030
LA	5249	Mueller, Glenn A.		110 Florida Boulevard SW	Denham Springs	70726	(225) 664-3030
LA	5250	Mueller, Glenn A.		990 W. Lee Drive, Suite E	Baton Rouge	70820	(225) 767-1100
LA	5251	Mueller, Glenn A.		2806 Government Street	Baton Rouge	70806	(225) 383-3030
LA	5252	Mueller, Glenn A.		1841 Staring Lane	Baton Rouge	70810	(225) 767-3480
LA	5254	Mueller, Glenn A.		205 North Canal Boulevard	Thibodaux	70301	(985) 324-8088
LA	5256	Mueller, Glenn A.		1050 Millerville Road	Baton Rouge	70816	(225) 273-3030
LA	5257	Mueller, Glenn A.		10595 Airline Highway	Baton Rouge	70816	(225) 291-5225
LA	5258	Mueller, Glenn A.		5443 Jones Creek Road	Baton Rouge	70817	(225) 751-8193
LA	5259	Patrick, Joseph Harold		3266 Plank Road	Baton Rouge	70805	(225) 359-6301
LA	5260	Megee, Matthew		2170 Main Street	Baker	70714	(225) 774-2166
LA	5261	Mueller, Glenn A.		107 E. University Avenue	Lafayette	70503	(337) 234-3030
LA	5262	Mueller, Glenn A.		611 Verot School Road	Lafayette	70508	(337) 261-0991
LA	5263	Mueller, Glenn A.		3241 Ambassador Caffery Parkway, Suite 102	Lafayette	70506	(337) 988-4724
LA	5265	Mueller, Glenn A.		402 West Highway 30, Suite E	Gonzales	70737	(225) 644-8484
LA	5266	Mueller, Glenn A.		4421 Lake Street	Lake Charles	70605	(337) 474-5591
LA	5267	Felix, Daniel		2018 Gerstner Memorial Drive	Lake Charles	70601	(337) 437-9000
LA	5269	Mueller, Glenn A.		2510 Veteran's Memorial Drive	Abbeville	70510	(337) 898-0730
LA	5270	Mueller, Glenn A.		1604 S. 5th Street	Leesville	71446	(337) 239-0665
LA	5272	Mueller, Glenn A.		1409 Military Highway	Pineville	71360	(318) 445-3223
LA	5273	Mueller, Glenn A.		534 Mcarthur Drive	Alexandria	71303	(318) 442-2440
LA	5274	Mueller, Glenn A.		101 South Drive	Natchitoches	71457	(318) 352-6382
LA	5275	Mueller, Glenn A.		110 Apollo Road, Suite B	Scott	70583	(337) 516-1030
LA	5276	Mueller, Glenn A.		212 Sterling Drive, Unit 6	Franklin	70538	(337) 828-5570
LA	5277	Mueller, Glenn A.		1132 N. Pine Street, Suite H	Deridder	70634	(337) 462-3030
LA	5278	Bergeron, Nicole M.		209 Tate Cove Road	Ville Platte	70586	(337) 346-5678
LA	5281	Mueller, Glenn A.		4112 Airline Drive	Bossier City	71111	(318) 747-3870
LA	5282	Mueller, Glenn A.		1002 A. Johnson Street	Bossier City	71112	(318) 747-9303
LA	5283	Bergeron, Nicole M.		7162 Highway 1	Marksville	71350	(318) 409-4160

Exhibit B Traditional
as of December 31, 2023

LA	5285	Fain, John Dwayne	3148 N. Market Street	Shreveport	71107	(318) 425-3278
LA	5287	Fain, John Dwayne	5604 Hearne Avenue	Shreveport	71108	(318) 631-3030
LA	5288	Mueller, Glenn A.	3432 Youree Drive	Shreveport	71105	(318) 222-7000
LA	5289	Mueller, Glenn A.	886 Bert Kouns Industrial Loop	Shreveport	71118	(318) 688-5730
LA	5290	Fain, John Dwayne	100 Lee Street	Minden	71055	(318) 371-0771
LA	5291	Barcomb, Calvin E	995 Tech. Drive	Ruston	71270	(318) 251-3030
LA	5292	Tucker, Freddie	1405 Sterlington Road	Monroe	71201	(318) 387-9887
LA	5293	Tucker, Freddie	4920 Cypress	W. Monroe	71291	(318) 397-2800
LA	5296	Magee, Matthew	19105 Florida Boulevard	Albany	70711	(225) 567-2500
LA	5297	Mueller, Glenn A.	5240 Elysian Fields Avenue	New Orleans	70122	(504) 267-7284
LA	5906	Carpenter, Penne L.	4896 Highway 1	Raceland	70394	(985) 532-3005
LA	9502	Mueller, Glenn A.	18590 Highway 16, Suite 5	Port Vincent	70726	(225) 698-3040
LA	9503	Rigsby, Jerrod Glenn	703 The Boulevard	Rayne	70578	(337) 393-2131
LA	9504	Mueller, Glenn A.	1501 Highway 90 E	Morgan City	70380	(985) 412-6996
LA	9505	Parnell, Rysean	3212 S Carrollton Avenue	New Orleans	70118	(504) 312-6060
LA	9506	Rigsby, Jerrod Glenn	1205 Elton Road	Jennings	70546	(337) 246-7401
LA	9507	Mueller, Glenn A.	2761 E. Milton Avenue, Ste A-1	Youngsville	70592	(337) 857-3090
MA	3056	Karakus, Yunus	186 Great Road, Suite #4	Bedford	01730	(781) 280-2929
MA	3066	Karakus, Yunus	345 Main Street, Unit 11A	Tewksbury	01876	(978) 234-2701
MA	3067	Garcia, Augusto S. Jr.	341 Appleton Street	Holyoke	01040	(413) 533-1155
MA	3068	Jones, Kris Rich	3821 Falmouth Road, Unit 4	Marstons Mills	02648	(508) 428-7900
MA	3069	Karakus, Yunus	1 Andover Street	Peabody	01960	(978) 536-3100
MA	3072	Taskaynatan, Murat	947 W. Boylston Street	Worcester	01606	(508) 853-1100
MA	3073	Taskaynatan, Murat	2 Bridge Approach Street	Bourne	02532	(774) 302-0500
MA	3074	Garcia, Augusto S. Jr.	670 Broadway Street	Chicopee	01020	(413) 593-9100
MA	3076	Dufficy, Jeffrey P.	2 Cape Road #2	Milford	01757	(508) 478-8000
MA	3078	Kilinc, Bentan	628-A Washington Street, U.S. Route 1	Dedham	02026	(781) 329-7999
MA	3079	Ceglarski III, Len	274 Main Street	Reading	01867	(781) 944-9144
MA	3081	Cashman, Jeannie Mae	85 Maple Street	Danvers	01923	(978) 777-8776
MA	3082	Baum, Christopher T.	53 Winn Street	Burlington	01803	(781) 229-1330
MA	3083	Gokdag, Celal Fatih	21-C Turnpike Road	Southborough	01772	(508) 481-3939
MA	3084	Garcia, Augusto S. Jr.	136 Walnut Street	Springfield	01105	(413) 827-0075
MA	3088	Zonfrilli, Joseph V.	80 Summer Street	Adams	01220	(413) 743-7170
MA	3089	Jones, Kris Rich	237 Falmouth Road	Hyannis	02601	(508) 790-1920
MA	3090	Mikhail, Tamer	118 Chelmsford Street	Chelmsford	01824	(978) 250-1555
MA	3092	Dufficy, Jeffrey P.	209 E. Central Street	Franklin	02038	(508) 520-0600
MA	3093	Rivard, Robert P.	61 Hancock Street	Quincy	02171	(617) 472-9191

Exhibit B Traditional
as of December 31, 2023

MA	3094	Jones, Kris Rich	484 Station Avenue, Unit E	Yarmouth	02664	(508) 394-6688
MA	3095	Mikhail, Tamer	161-163 Westford Road	Tyngsboro	01879	(978) 234-3001
MA	3138	Gungor, Unal	423 Boston Post Road	Sudbury	01776	(978) 443-0007
MA	3141	Baum, Christopher T.	386 Chelmsford Street	Lowell	01851	(978) 441-1000
MA	3145	Kilinc, Bentan	240 Chestnut Street	Needham	02492	(781) 449-5599
MA	3180	Zonfrilli, Joseph V.	1212 County Street	Somerset	02726	(508) 673-9700
MA	3183	Karakus, Yunus	137 Massachusetts Avenue	Lexington	02420	(781) 676-7900
MA	3184	Jones, Kris Rich	16 Main Street	West Harwich	02671	(508) 430-7400
MA	3185	Dufficy, Jeffrey P.	126 Main Street	Medway	02053	(508) 533-5900
MA	3186	Keery, David J.	312 Springfield Street	Agawam	01001	(413) 821-0800
MA	3188	Garcia, Augusto S. Jr.	790 Liberty Street	Springfield	01104	(413) 827-8400
MA	3189	Cevik, Cenk	75 Great Road	Acton	01720	(978) 264-4141
MA	3191	Gozalici, Ben	225 Bedford Street	East Bridgewater	02333	(508) 350-9775
MA	3194	Ferreira, Carlos H.	1085 N. Montello Street	Brockton	02301	(508) 587-1299
MA	3197	Gozalici, Ben	5 Main Street, Unit #15	Plymouth	02360	(508) 747-7500
MA	3218	Dufficy, Jeffrey P.	163 Old Colony Avenue	South Boston	02127	(617) 268-2900
MA	3229	Jones, Kris Rich	280 Route 130, Building C, Unit #6	Sandwich	02563	(508) 888-7757
MA	3238	Dufficy, Jeffrey P.	207 Adams Street	Dorchester	02122	(617) 282-2424
MA	3253	Garcia, Augusto S. Jr.	1273 Memorial Drive	Chicopee	01020	(413) 593-9500
MA	3255	Dufficy, Jeffrey P.	72 Church Street	Whitinsville	01588	(508) 266-2000
MA	3274	Mikhail, Tamer	527 Groton Road	Westford	01886	(978) 589-9988
MA	3700	Garcia, Augusto S. Jr.	907 Sumner Avenue	Springfield	01118	(413) 734-7154
MA	3701	Naves, Paulo R.	26 Main Street	Westfield	01085	(413) 562-4411
MA	3703	Garcia, Augusto S. Jr.	624 Boston Road	Springfield	01119	(413) 782-8601
MA	3705	Zonfrilli, Joseph V.	321 1/2 Elm Street	Pittsfield	01201	(413) 499-3994
MA	3706	Dec, James Z.	63 Park Street, Ste 2	Andover	01810	(978) 474-0066
MA	3707	Dufficy, Jeffrey P.	235 Chauncy Street	Mansfield	02048	(508) 543-4133
MA	3708	Gokdag, Celal Fatih	868 Worcester Street	Wellesley	02482	(781) 235-6800
MA	3710	Akers, Scott D.	368 Federal Street	Greenfield	01301	(413) 774-7291
MA	3712	Zonfrilli, Joseph V.	1 River Street	North Adams	01247	(413) 663-6363
MA	3713	Karakus, Yunus	671 Massachusetts Avenue	Arlington	02476	(781) 643-2300
MA	3714	Mikhail, Tamer	743 Main Street	Winchester	01890	(781) 729-8844
MA	3715	Baum, Christopher T.	199 Mystic Avenue	Medford	02155	(781) 395-0080
MA	3716	Ceglarski III, Len	385 Franklin Street	Melrose	02176	(781) 665-0049
MA	3717	Taskaynatan, Murat	1413 Grafton Street	Worcester	01604	(508) 797-1122
MA	3718	Jenks / Benvenuti, David / Dominic	775 Eastern Avenue	Malden	02148	(781) 322-0030
MA	3719	El-Sibai, Mohammad A.	201 Elm Street	Somerville	02144	(617) 629-2929

Exhibit B Traditional
as of December 31, 2023

MA	3720	Mogul, Nancy			459 Russell Street	Hadley	01035	(413) 256-8911
MA	3721	Kalay, Serhan			1899 Ocean Street, Unit D5	Marshfield	02050	(781) 837-7700
MA	3722	Akers, Scott D.			11 Union Street	Easthampton	01027	(413) 527-0821
MA	3723	Benson, Robert E.			100 Market Street	Rockland	02370	(781) 871-3030
MA	3724	Jenks / Benvenuti, David / Dominic			1400 Tremont Street D	Roxbury Crossing	02120	(617) 541-3525
MA	3725	Taskaynatan, Murat			189 Marion Road	Wareham	02571	(508) 295-0201
MA	3726	Dufficy, Jeffrey P.			55 Lake Street	Webster	01570	(508) 949-1330
MA	3729	Dufficy, Jeffrey P.			825 Main Street	Southbridge	01550	(508) 765-0822
MA	3730	Baum, Christopher T.			304 Park Avenue	Worcester	01609	(508) 754-2236
MA	3731	Bell, Keith			116 Main Street	Pepperell	01463	(978) 743-0091
MA	3732	Jenks / Benvenuti, David / Dominic			141 Water Street	Fitchburg	01420	(978) 342-0050
MA	3733	Jenks / Benvenuti, David / Dominic			401 Parker Street	Gardner	01440	(978) 632-8170
MA	3734	Jenks / Benvenuti, David / Dominic			58 Central Street	Leominster	01453	(978) 534-3355
MA	3736	Akers, Scott D.			241 King Street, Suite 115	Northampton	01060	(413) 584-2111
MA	3737	Polvay, Andrew L.			1023 Washington Street	Norwood	02062	(781) 769-7800
MA	3738	Baum, Christopher T.			281 Concord Street	Framingham	01702	(508) 620-4975
MA	3739	Karakus, Yunus			13 Pleasant Street	Spencer	01562	(774) 371-8383
MA	3741	Jenks / Benvenuti, David / Dominic			508 Park Drive	Boston	02215	(617) 424-9000
MA	3742	Jenks / Benvenuti, David / Dominic			414 Cambridge Street	Allston	02134	(617) 254-4800
MA	3743	Gokdag, Celal Fatih			878 Walnut Street	Newton	02459	(617) 332-7222
MA	3744	Kilinc, Bentan			4640 Washington Street	Roslindale	02131	(617) 323-0525
MA	3745	Gokdag, Celal Fatih			464 Washington Street	Brighton	02135	(617) 782-5655
MA	3746	Saroufim, Rabih Chaouki			111 Arsenal Street	Watertown	02472	(617) 923-3030
MA	3747	Dec, James Z.			173 Fairmount Avenue	Hyde Park	02136	(617) 364-6550
MA	3748	El-Sibai, Mohammad A.			1033 Massachusetts Avenue	Cambridge	02138	(617) 441-2101
MA	3749	Baum, Christopher T.			570 Broadway	Revere	02151	(781) 289-1020
MA	3750	Rivard, Robert P.			225 Quincy Avenue	Quincy	02169	(617) 328-6801
MA	3751	Baum, Christopher T.			729 Boston Road	Billerica	01821	(978) 663-3000
MA	3752	Zonfrilli, Joseph V.			1229 North Street	Pittsfield	01201	(413) 499-7979
MA	3755	Kilinc, Bentan			240 Trepelo Road	Belmont	02478	(617) 489-4242
MA	3756	Bell, Keith			321 Main Street	Athol	01331	(978) 330-7676
MA	3757	Karakus, Yunus			1899 Main Street, Unit #3	Tewksbury	01876	(978) 858-0777
MA	3758	Baum, Christopher T.			707 Western Avenue	Lynn	01905	(781) 581-8080
MA	3759	Baum, Christopher T.			58-62 South Broadway	Lawrence	01843	(978) 685-1001
MA	3760	Rivard, Robert P.			821 Rockdale Avenue	New Bedford	02740	(508) 999-2911
MA	3761	Ferreira, Carlos H.			407 S. Main Street	Fall River	02721	(508) 676-3030
MA	3762	Rivard, Robert P.			836 Ashley Boulevard	New Bedford	02745	(508) 996-3030

Exhibit B Traditional
as of December 31, 2023

MA	3763	Ferreira, Carlos H.			933 Pleasant Street	Fall River	02723	(508) 672-3030
MA	3764	Rivard, Robert P.			109 Rockdale Avenue	New Bedford	02740	(508) 991-3030
MA	3765	Dec, James Z.			173 State Street	Newburyport	01950	(978) 465-0360
MA	3766	Ferreira, Carlos H.			183 Broadway Street	Taunton	02780	(508) 880-0111
MA	3767	Bell, Keith			100 Macy Street, Suite 1	Amesbury	01913	(978) 792-7007
MA	3768	Dufficy, Jeffrey P.			28 East Washington Street	North Attleboro	02760	(508) 699-0500
MA	3769	Jenks / Benvenuti, David / Dominic			382 Main Street	Gloucester	01930	(978) 281-5480
MA	3770	Jenks / Benvenuti, David / Dominic			4 Canal Street	Salem	01970	(978) 744-4040
MA	3771	Baum, Christopher T.			71-73 Mammoth Road	Lowell	01854	(978) 454-7474
MA	3772	Andrade, Sara			56 Main Street	Lakeville	02347	(508) 492-3030
MA	3773	Baum, Christopher T.			1144 Saratoga Street	East Boston	02128	(617) 567-5551
MA	3774	Baum, Christopher T.			90 Lakeview Avenue	Lowell	01850	(978) 452-3030
MA	3775	Ferreira, Carlos H.			1940 Main Street	Brockton	02301	(508) 588-3412
MA	3776	Andrade, Sara			177 Huttleston Avenue	Fairhaven	02719	(508) 204-7272
MA	3777	Garcia, Augusto S. Jr.			2030 Boston Road	Wilbraham	01095	(413) 648-8889
MA	3778	Dufficy, Jeffrey P.			271 County Street	Attleboro	02703	(508) 226-6000
MA	3779	Jones, Kris Rich			667 Teaticket Highway	Teaticket	02536	(508) 540-8004
MA	3780	Bell, Keith			33 Main Street	Belchertown	01007	(413) 461-3222
MA	3782	Jenks / Benvenuti, David / Dominic			43 Beckford Street	Beverly	01915	(978) 927-2999
MA	3783	Bell, Keith			610 Main Street	Clinton	01510	(978) 598-3003
MA	3784	Jenks / Benvenuti, David / Dominic			64 Staniford Street	Boston	02114	(617) 248-0100
MA	3785	Baum, Christopher T.			14 Jackson Street	Methuen	01844	(978) 685-2525
MA	3786	Baum, Christopher T.			54 Main Street	Marlborough	01752	(508) 481-5335
MA	3787	Jenks / Benvenuti, David / Dominic			130 Main Street	Haverhill	01830	(978) 372-5660
MA	3788	Gungor, Yasemin Sule			136 Main Street	Hudson	01749	(978) 562-7755
MA	3789	Gokdag, Celal Fatih			25 Main Street	Wayland	01778	(508) 651-8210
MA	3790	Karakus, Yunus			4000 Washington Street	Rosindale	02131	(617) 318-6100
MA	3791	Ferreira, Carlos H.			137 Hart Street	Taunton	02780	(508) 258-9978
MA	3792	Ferreira, Carlos H.			289 Winthrop Street, Unit 3A	Taunton	02780	(508) 571-1500
MA	3793	Dufficy, Jeffrey P.			205 Lexington Street	Waltham	02452	(781) 894-4848
MA	3794	Dufficy, Jeffrey P.			1177 North Main Street	Randolph	02368	(781) 986-3030
MA	3795	Ferreira, Carlos H.			390 Rhode Island Avenue, Unit 4	Fall River	02724	(508) 677-3030
MA	3796	Benson, Robert E.			270 Main Street, Unit 3, Bldg. A	Hanson	02341	(781) 293-4500
MA	3797	Dufficy, Jeffrey P.			1514 Blue Hill	Mattapan	02126	(617) 298-0900
MA	3904	Andrade, Sara			711 Southbridge Street	Auburn	01501	(508) 936-3030
MA	3993	El-Sibai, Mohammad A.			277-279 Main Street	Charlestown	02129	(617) 419-4400
MA	3997	Rivard, Robert P.			824 Washington Street	Weymouth	02189	(781) 682-9000

Exhibit B Traditional
as of December 31, 2023

MA	6094	Dufficy, Jeffrey P.				246 Boston Turnpike	Shrewsbury	01545	(508) 842-8200
MA	9800	Gozalici, Ben				2 Norfolk Road	Holbrook	02343	(781) 805-8100
MA	9801	Gozalici, Ben				100 -C Washington Street	Canton	02021	(781) 562-0655
MA	9802	Karakus, Yunus				1219 Thorndike Street	Palmer	01069	(413) 289-6245
MA	9803	Ferreira, Carlos H.				646 Washington Street	South Easton	02375	(508) 297-1166
MA	9804	Dufficy, Jeffrey P.				276 Turnpike Road, Route 9-East	Westborough	01581	(508) 768-0030
MA	9805	Eriman, Nur Aysin				430 Paradise Road	Swampscott	01907	(781) 715-2220
MA	9806	Taskaynatan, Murat				1142 Main Street	Holden	01520	(508) 829-1919
MA	9807	Jenks / Benvenuti, David / Dominic				66 East Main Street	GEORGETOWN	01833	(978) 352-0752
MA	9808	Karakus, Yunus				341 Union Street	Lynn	01901	(781) 581-8085
MA	9809	Karakus, Yunus				124 West Street	Ware	01082	(413) 277-6260
MD	3998	Bhatti, Zafeer Ahmed				4000 Hayman Drive	Federalsburg	21632	(410) 754-7007
MD	4450	Barber, John C.				104 64th Street	Ocean City	21842	(410) 723-5400
MD	4609	Clise, Michael W.				141 N. Prospect Street	Hagerstown	21740	(301) 733-3333
MD	4611	Barber, John C.				10225 Berry Road	Waldorf	20603	(301) 478-6400
MD	4614	Clise, Michael W.				1520 York Road	Lutherville	21093	(240) 734-1030
MD	4629	Mohammad, Nadar Masood				607-A Reisterstown Road	Baltimore	21208	(410) 580-5511
MD	4631	O'Neill, Louis C.				18214 Flower Hill Way	Gaithersburg	20879	(301) 869-3000
MD	4632	O'Neill, Louis C.				8700 Flower Avenue	Silver Spring	20901	(301) 589-1300
MD	4634	Angulo, Hayden				274 N. Frederick Road	Gaithersburg	20877	(301) 990-2400
MD	4638	O'Neill, Louis C.				5268 E. Nicholson Lane	Kensington	20895	(301) 230-3030
MD	4642	O'Neill, Louis C.				9509 Lanham-Severn Road	Seabrook	20706	(301) 459-3500
MD	4643	O'Neill, Louis C.				2500 University Boulevard E.	Hyattsville	20783	(301) 408-0282
MD	4644	Carter, Malcolm				9509 Livingston Road	Ft Washington	20744	(301) 248-3030
MD	4645	O'Neill, Louis C.				4717 Baltimore Avenue	Hyattsville	20781	(301) 699-5880
MD	4646	O'Neill, Louis C.				7699 Annapolis Road	New Carrollton	20784	(301) 731-1111
MD	4648	O'Neill, Louis C.				10486 Baltimore Avenue	Beltsville	20705	(301) 937-7776
MD	4649	O'Neill, Louis C.				7312 Baltimore Avenue	College Park	20740	(301) 852-3030
MD	4650	Treacy, Edward W. III				4959 Westview Drive, Suite 4	Frederick	21703	(301) 750-7600
MD	4651	Carter, Malcolm				6000 Allentown Andrews Drive, Suite 102	Suitland	20747	(301) 449-3030
MD	4653	Carter, Malcolm				2950-A Donnell Drive	Forestville	20747	(301) 568-8883
MD	4654	Barber, John C.				25805 Point Lookout Road, Unit B	Leonardtown	20650	(301) 750-7070
MD	4657	O'Neill, Louis C.				796 Harry S. Truman Drive	Largo	20772	(301) 499-5100
MD	4658	O'Neill, Louis C.				8904 62nd Avenue	Benwyn Heights	20740	(301) 474-3030
MD	4659	Barber, John C.				3147 Solomons Island Road	Edgewater	21037	(410) 956-1800
MD	4661	O'Neill, Louis C.				3544 NW Robert Crain Highway	Bowie	20716	(301) 390-7711
MD	4662	Treacy, Edward W. III				1 Worman's Mill Court #2	Frederick	21701	(301) 696-1600

Exhibit B Traditional
as of December 31, 2023

MD	4668	Angulo, Hayden	415 E. Dover Road	Easton	21601	(410) 820-8330
MD	4669	Treacy, Edward W. III	457 Baltimore Boulevard	Westminster	21157	(410) 857-5554
MD	4671	Abedalfattah, Hany Sayed Ahmed	240 Colonial Way Plaza, Suite A	Rising Sun	21911	(410) 658-1786
MD	4672	Sparks, Joseph Wayne	5301 Pulaski Highway	Perryville	21903	(410) 642-5555
MD	4674	Barber, John C.	2215 Crain Highway, Suite F	Waldorf	20601	(301) 645-3030
MD	4675	Barber, John C.	371 Smallwood Drive	Waldorf	20602	(301) 932-8300
MD	4677	Prouse, Donald M. Jr.	119 Big Elk Mall	Elkton	21921	(443) 246-8888
MD	4679	Prouse, Donald M. Jr.	1121 S. Salisbury Boulevard	Salisbury	21801	(410) 742-6900
MD	4680	Prouse, Donald M. Jr.	1730 N. Salisbury Boulevard	Salisbury	21801	(410) 546-6900
MD	4681	Prouse, Donald M. Jr.	2753 Dorchester Square, Suite D	Cambridge	21613	(410) 228-0100
MD	4682	Angulo, Hayden	13050 Middlebrook Road	Germantown	20874	(301) 540-3388
MD	4683	Clise, Michael W.	17549 Virginia Avenue	Hagerstown	21740	(301) 791-0700
MD	4684	Treacy, Edward W. III	3254-B Bennett Creek Avenue	Frederick	21704	(240) 341-4692
MD	4685	Angulo, Hayden	21040-E Frederick Road	Germantown	20876	(301) 972-3388
MD	4686	O'Neill, Louis C.	7311 Macarthur Boulevard	Bethesda	20816	(301) 913-9700
MD	4687	O'Neill, Louis C.	9450 Georgia Avenue	Silver Springs	20901	(301) 589-3030
MD	4690	Barber, John C.	21765 Great Mills Road	Lexington Park	20653	(301) 863-2700
MD	4691	Treacy, Edward W. III	1080 West Patrick Street, Unit 11	Frederick	21703	(301) 698-0266
MD	4692	O'Neill, Louis C.	10145 New Hampshire Avenue	Silver Spring	20903	(301) 445-3030
MD	4693	O'Neill, Louis C.	4817 Street Elmo Avenue	Bethesda	20814	(301) 913-5700
MD	4696	Mohammad, Nadar Masood	3502 Brenbrook Drive	Randallstown	21133	(410) 496-2020
MD	6009	Clise, Michael W.	74 Souder Road, Unit 74	Brunswick	21716	(301) 834-3000
MD	6017	Carter, Malcolm	6254 Central Avenue	Seat Pleasant	20743	(301) 333-5900
MD	6024	Koscielniak, Amy D.	518 Washington Avenue	Chestertown	21620	(410) 810-3811
MD	6026	Clise, Michael W.	18726 North Pointe Drive, Suite D	Hagerstown	20742	(301) 766-9030
MD	6029	Carter, Malcolm	9546 Crain Highway, Store #J	Upper Marlboro	20772	(301) 599-4100
MD	6061	Barber, John C.	7861 Bayside Road	Chesapeake Beach	20732	(410) 257-3040
MD	6062	Angulo, Hayden	18037 Georgia Avenue	Olney	20832	(301) 570-3800
MD	6063	Treacy, Edward W. III	12962 Travilah Road	Potomac	20854	(301) 330-0000
MD	6064	Treacy, Edward W. III	26437 Ridge Road	Damascus	20872	(301) 253-8880
MD	6065	O'Neill, Louis C.	1617 East Gude	Rockville	20850	(301) 309-3880
MD	6066	Barber, John C.	23415 Three Notch Rd	California	20619	(301) 245-7900
MD	6067	Treacy, Edward W. III	15530 Old Columbia Pike	Burtonsville	20866	(301) 421-0112
MD	6069	Barber, John C.	509 Charles Street	La Plata	20646	(301) 932-0333
MD	6070	O'Neill, Louis C.	13659 Georgia Avenue	Silver Spring	20906	(301) 949-1401
MD	6071	O'Neill, Louis C.	11937 Georgia Avenue	Silver Spring	20902	(301) 933-3339
MD	6072	Bhatti, Zafeer Ahmed	386 Thompson Creek Mail	Stevensville	21666	(410) 643-3002

Exhibit B Traditional
as of December 31, 2023

MD	6074	Treacy, Edward W. III	431 E. Ridgeville Boulevard	Mt Airy	21771	(301) 829-5400
MD	6077	Treacy, Edward W. III	1207 Liberty Road	Eldersburg	21784	(410) 795-2400
MD	6078	Carter, Malcolm	14604 Main St	Upper Marlboro	20772	(301) 952-1133
MD	6079	Barber, John C.	5735 Deale-Churchton Road, Unit #2	Deale	20751	(410) 867-3003
MD	6080	Treacy, Edward W. III	2275 Hanover Pike	Hampstead	21074	(410) 374-1600
MD	6081	Barber, John C.	21 Church Street	Prince Frederick	20678	(410) 535-0101
MD	6082	Treacy, Edward W. III	11717 Old National Pike, Unit 18	New Market	21774	(301) 865-0200
MD	6083	Clise, Michael W.	4316-B Old National Pike	Middletown	21769	(301) 371-5801
MD	6084	Barber, John C.	30165 Triangle Drive	Charlotte Hall	20622	(301) 884-3055
MD	6085	Barber, John C.	7091 Indian Head Highway	Bryans Road	20616	(301) 375-6006
MD	6086	Barber, John C.	11121 Ocean Gateway	Berlin	21811	(410) 641-6900
MD	6088	Carter, Malcolm	10367 Southern Maryland Boulevard	Dunkirk	20754	(410) 286-0700
MD	6089	Barber, John C.	11739 HG Trueman Road, Suite E103	Lusby	20657	(410) 394-0600
MD	6092	Prouse, Donald M. Jr.	1212 Pemberton Drive	Salisbury	21801	(410) 341-6900
MD	6100	Sparks, Joseph Wayne	2328 Pulaski Highway	North East	21901	(443) 967-0550
MD	6106	Bhatti, Zafeer Ahmed	2478 E. Centreville Road	Centreville	21617	(410) 758-3773
MD	6115	Treacy, Edward W. III	350 Fortune Terrace	Potomac	20854	(301) 315-8383
MD	6116	Bear, Amber N.	10518 Greensboro Road	Denton	21629	(410) 479-5600
MD	6199	Grieg, David V.	124 Newtown Boulevard	Pocomoke City	21851	(410) 957-2424
MD	9354	Malament, Charles L.	32 Queens City Drive	Cumberland	21502	(301) 722-0022
MD	9355	Malament, Charles L.	16 Maple Street, Suite 2	Frostburg	21532	(301) 689-8899
MD	9356	Clise, Michael W.	4 Tiger Way	Boonsboro	21713	(301) 349-3300
MD	9357	Carter, Malcolm	4269 Branch Avenue #54	Temple Hills	21237	(301) 839-0330
ME	3000	Prior, Lee S.	496 Stillwater Avenue	Orono	04468	(207) 817-6090
ME	3001	Jenks / Benvenuti, David / Dominic	788 Forest Avenue	Portland	04103	(207) 774-1489
ME	3002	Jenks / Benvenuti, David / Dominic	1095 Broadway	S. Portland	04106	(207) 799-8131
ME	3003	Jenks / Benvenuti, David / Dominic	450 US Route 1	Kittery	03904	(207) 439-1300
ME	3004	Ruszenas, Tiffani	8 Heath Street, Suite 1	Old Orchard Beach	04064	(207) 690-4141
ME	3005	Ruszenas, Tiffani	111 Elm Street & 5 Pearl Street	Biddeford	04005	(207) 282-3388
ME	3006	Stelser, Fernando J.	596 Wilton Road	Farmington	04938	(207) 860-4545
ME	3008	Prior, Lee S.	58 Ossipee Trail East	Standish	04084	(207) 642-5200
ME	3009	Stelser, Fernando J.	66 Main Street	Norway	04268	(207) 739-7039
ME	3010	Prior, Lee S.	974 Main Street	Sanford	04073	(207) 324-1000
ME	3013	Prior, Lee S.	14 Heathwood Drive	Windham	04062	(207) 892-2500
ME	3014	Prior, Lee S.	621 Main Street	Gorham	04038	(207) 854-2500
ME	3015	Stelser, Fernando J.	4 Oak Grove Avenue	Bath	04530	(207) 443-4343
ME	3019	Jenks / Benvenuti, David / Dominic	12 Sullivan Street, Suite 104	Berwick	03901	(207) 800-1500

Exhibit B Traditional
as of December 31, 2023

ME	3020	Stelser, Fernando J.	208 Maine Street	Brunswick	04011	(207) 729-5561
ME	3021	Prior, Lee S.	42 Elm Street	Waterville	04901	(207) 873-0100
ME	3022	Stelser, Fernando J.	28 Western Avenue	Augusta	04330	(207) 622-1900
ME	3023	Stelser, Fernando J.	62 School Street	Auburn	04210	(207) 783-2200
ME	3024	Prior, Lee S.	6 Clinton Street	Bangor	04401	(207) 947-2100
ME	3025	Prior, Lee S.	212 Park Street	Rockland	04841	(207) 594-9494
ME	3040	Prior, Lee S.	878 Stillwater Avenue	Bangor	04401	(207) 941-1900
ME	3041	Stelser, Fernando J.	1104 Lisbon Street	Lewiston	04240	(207) 344-3400
ME	3042	Prior, Lee S.	127 North Street	Houlton	04730	(207) 538-3131
ME	3085	Prior, Lee S.	379 Main Street	Presque Isle	04769	(207) 554-5154
ME	3091	Stelser, Fernando J.	8 School Street	Freeport	04032	(207) 869-6000
ME	9563	Stelser, Fernando J.	192 Water Street	Gardiner	04345	(207) 203-2200
ME	9564	Ruszenas, Tiffani	45 Portland Road	Kennebunk	04043	(207) 985-0345
ME	9565	Stelser, Fernando J.	586 Lisbon Street	Lisbon	04252	(207) 407-8900
MI	1008	Dolkowski, Aaron	30336 W. Nine Mile Road	Farmington	48336	(248) 471-0594
MI	1010	Dolkowski, Aaron	41728 West Ten Mile Road	Novi	48375	(248) 349-9101
MI	1012	Dolkowski, Aaron	14100 Fort Street	Southgate	48195	(734) 933-6000
MI	1014	Dolkowski, Aaron	16136 Middlebelt Road	Livonia	48154	(734) 422-2100
MI	1016	Dolkowski, Aaron	9567 Main Street	Whitmore Lake	48189	(734) 333-9633
MI	1022	Dolkowski, Aaron	30068 Ford Road	Garden City	48135	(734) 655-9223
MI	1025	Dolkowski, Aaron	23960 Carlysle Steet	Dearborn	48124	(313) 637-1010
MI	1027	Seck, Lamine	16005 W. McNichols Road	Detroit	48235	(313) 548-0880
MI	1034	Dally, Jason	20431 Mack Avenue	Grosse Pointe Woods	48236	(313) 884-9750
MI	1035	Seck, Lamine	3535 Caniff Street, Suite C	Hamtramck	48212	(313) 915-4544
MI	1036	Seck, Lamine	13250 Gratot Avenue	Detroit	48207	(313) 839-6700
MI	1040	Dolkowski, Aaron	44350 Cherry Hill Road	Canton	48187	(734) 844-6000
MI	1041	Dolkowski, Aaron	1043 Ann Arbor Road	Plymouth	48170	(734) 207-1000
MI	1043	Wells, Michael	5164 Lake Michigan Drive	Allendale	49401	(616) 986-1500
MI	1050	Dolkowski, Aaron	35173 E. Michigan Avenue	Wayne	48184	(734) 722-3030
MI	1051	Arnison, Eric	412 Oaks Crossing	Plainwell	49080	(269) 680-3900
MI	1052	Arnison, Eric	484 N. Perry Street	Pontiac	48342	(616) 824-2005
MI	1054	Redies, Joshua Daniel	10531 Highland Road	White Lake	48386	(248) 716-5551
MI	1065	Redies, Joshua Daniel	4048 Grange Hall Road, Suite E	Holly	48442	(248) 534-1151
MI	1068	Dolkowski, Aaron	29854 Northwestern Highway	Southfield	48034	(248) 352-6590
MI	1070	Redies, Joshua Daniel	825 South State Street, Suite A	Davison	48423	(810) 379-9500
MI	1071	Arnison, Eric	1236 S. Martin Luther King Jr. Drive	Jackson	49203	(517) 787-0505
MI	1074	Redies, Joshua Daniel	913 North Leroy Street	Fenton	48430	(810) 433-4544

Exhibit B Traditional
as of December 31, 2023

MI	1077	Dally, Jason	2767 E. 14 Mile Road	Sterling Heights	48310	(586) 264-9200
MI	1078	Dally, Jason	28651 Southfield Road	Lathrup Village	48076	(248) 864-5777
MI	1081	Dolkowski, Aaron	22235 Pontiac Trail	South Lyon	48178	(248) 617-1500
MI	1085	Dolkowski, Aaron	27609 Plymouth Road	Livonia	48150	(734) 655-0965
MI	1092	Dolkowski, Aaron	17675 Eureka Road	Southgate	48195	(734) 281-3833
MI	1094	Dolkowski, Aaron	222 Grand River Avenue	Brighton	48116	(810) 355-4935
MI	1097	Redies, Joshua Daniel	130 Perry Road	Grand Blanc	48439	(810) 771-9080
MI	1098	Arnison, Eric	101 N. Clinton Avenue	St. Johns	48879	(989) 403-7575
MI	1100	Cesarini, David L.	2601 Plymouth Road, Suite B	Ann Arbor	48105	(734) 663-3333
MI	1101	Redies, Joshua Daniel	953 Washtenaw Avenue	Ypsilanti	48197	(734) 482-5555
MI	1102	Cesarini, David L.	25 Jackson Industrial Drive, Unit 4	Ann Arbor	48103	(734) 913-8888
MI	1107	Redies, Joshua Daniel	401 East Michigan Avenue	Saline	48176	(734) 944-4555
MI	1108	Young, Paul A	2121 S. Grove Street	Ypsilanti	48198	(734) 483-8000
MI	1109	Cesarini, David L.	2282 S. Main Street	Ann Arbor	48103	(734) 332-1111
MI	1110	Dolkowski, Aaron	8017 N. Wayne Road	Westland	48185	(734) 525-2222
MI	1114	Watson, Sally A.	1113 Beecher Street	Adrian	49221	(517) 263-0678
MI	1117	Redies, Joshua Daniel	4910 Washtenaw Road	Ann Arbor	48108	(734) 528-1111
MI	1118	Cesarini, David L.	716 Packard Street	Ann Arbor	48103	(734) 769-4444
MI	1119	Arnison, Eric	1105 E. Grand River Avenue	East Lansing	48823	(517) 619-1234
MI	1128	Dolkowski, Aaron	1876 N. Latson Road	Howell	48843	(517) 376-6940
MI	1132	Dally, Jason	16042 15 Mile Road	Fraser	48026	(586) 541-8686
MI	1133	Arnison, Eric	3151 Breton Avenue SE	Kentwood	49512	(616) 771-0000
MI	1138	Arnison, Eric	1025 Division Avenue South	Grand Rapids	49507	(616) 475-5555
MI	1139	Dally, Jason	15143 W. 10 Mile	Eastpointe	48021	(586) 447-3100
MI	1140	Dally, Jason	27883 Harper Avenue	St. Clair Shores	48081	(586) 771-2800
MI	1141	Dolkowski, Aaron	740 Benstein Road	Commerce Township	48390	(248) 960-0600
MI	1143	Lambert, Adam K.	21 Lowrie Drive	Gladstone	49837	(906) 428-6075
MI	1144	Morey, David Allen Jr.	5930 Cleveland Avenue	Stevensville	49127	(269) 556-7030
MI	1147	Arnison, Eric	4038 Alpine Avenue NW	Comstock	49321	(616) 369-9466
MI	1148	Arnison, Eric	630 S. State Street	Sparta	49345	(616) 887-8000
MI	1149	Redies, Joshua Daniel	858 S. Main Street	Lapeer	48446	(810) 356-7772
MI	1160	Arnison, Eric	616 W. Main Street	Owosso	48867	(989) 725-5000
MI	1163	Dally, Jason	35785 Harper Avenue	Clinton Twp.	48035	(586) 791-5900
MI	1165	Lambert, Adam K.	200 Pearl Street, Suite 4 & 5	Houghton	49931	(906) 482-6060
MI	1166	Lambert, Adam K.	719 Ashum Street	Sault Ste Marie	49783	(906) 632-4000
MI	1167	Arnison, Eric	5645 S. Cedar Street	Lansing	48911	(517) 999-7992
MI	1169	Sack, Lamine	1636 E. Eight Mile Road	Detroit	48203	(313) 368-9368

Exhibit B Traditional
as of December 31, 2023

MI	1175	McGraw, Mark	400 East Division, Suite 4	Rockford	49341	(616) 951-4111
MI	1178	Carlson, Duane L. Jr.	135 E. Aurora Street	Ironwood	49938	(906) 364-7209
MI	1180	Arnison, Eric	3928 Plainfield Avenue NE	Grand Rapids	49525	(616) 710-4545
MI	1182	Dally, Jason	6115-A East Ten Mile Road	Warren	48091	(586) 619-9590
MI	1184	Dolkowski, Aaron	6081 Haggerty Road	West Bloomfield	48322	(248) 313-9111
MI	1188	Dally, Jason	1317 East Eleven Mile	Royal Oak	48067	(248) 691-9000
MI	1190	Dolkowski, Aaron	7126 Pardee Road	Taylor	48180	(313) 299-9400
MI	1191	McMullen, Timothy Y.	840 South State, Suite A2	Big Rapids	49370	(231) 796-5813
MI	1193	Arnison, Eric	1701 S. Waverly Road	Lansing	48917	(517) 999-5050
MI	1194	Arnison, Eric	327 South Bridge Street	Grand Ledge	48837	(517) 731-6501
MI	1196	Schloemann, Chris A.	4041 Euclid Avenue	Bay City	48706	(989) 459-1111
MI	1201	Arnison, Eric	143 N. Harrison Road, Suite 200	East Lansing	48823	(517) 351-7100
MI	1202	Redies, Joshua Daniel	7081 Dixie Highway	Clarkston	48346	(248) 707-3111
MI	1206	Hunnicut, Kathy J.	4750 Central Park Drive, Suite B	Okemos	48864	(517) 349-0030
MI	1207	Arnison, Eric	1019 E. State Road	Lansing	48906	(517) 482-1656
MI	1208	Arnison, Eric	234 S. Washington Square	Lansing	48933	(517) 372-3030
MI	1211	Pavilk, David M.	2068 Cedar Street	Holt	48842	(517) 694-8115
MI	1212	Arnison, Eric	2015 North Larch Street	Lansing	48906	(517) 624-0255
MI	1213	Arnison, Eric	4800 W. Saginaw Highway	Lansing	48917	(517) 323-7575
MI	1217	Schloemann, Chris A.	2700 State Street	Saginaw	48602	(989) 792-0030
MI	1219	Schloemann, Chris A.	3520 West Vienna Road	Clio	48420	(810) 368-3030
MI	1221	Morey, David Allen Jr.	1927 Pipestone Road	Benton Harbor	49022	(269) 252-4499
MI	1222	Arnison, Eric	912 W. Michigan Avenue	Marshall	49068	(269) 248-3700
MI	1223	Mueller, Glenn A.	5585 Gull Road, Suite 108	Kalamazoo	49048	(269) 459-2323
MI	1227	Mueller, Glenn A.	4129 Portage Street	Kalamazoo	49001	(269) 443-8501
MI	1228	Arnison, Eric	701 Olds Street	Jonesville	49250	(517) 826-1200
MI	1235	Arnison, Eric	780 Capital Avenue NE	Battle Creek	49017	(269) 883-8370
MI	1236	Arnison, Eric	1380 Wright Avenue	Alma	48801	(989) 533-5030
MI	1238	Schloemann, Chris A.	2804 Rodd Street	Midland	48640	(989) 835-3030
MI	1240	Arnison, Eric	706 S. Mission Street	Mt. Pleasant	48858	(989) 775-7555
MI	1242	Arnison, Eric	6539 28th Street SE	Grand Rapids	49546	(616) 512-3030
MI	1245	Schloemann, Chris A.	521 Washington Avenue	Bay City	48708	(989) 892-2520
MI	1248	Morey, David Allen Jr.	2080 Niles Road #100	St. Joseph	49085	(269) 982-0700
MI	1249	McKelvie, Matthew	1435 N. Mitchell Street, Suite A	Cadillac	49601	(231) 577-9900
MI	1250	McMullen, Timothy Y.	3480 South Airport Road W.	Traverse City	49684	(231) 600-7444
MI	1251	McMullen, Timothy Y.	748 Munson Avenue, Suite #2	Traverse City	49686	(231) 941-5355
MI	1253	Arnison, Eric	264 N. River Avenue, Suite 20	Holland	49424	(616) 392-4999

Exhibit B Traditional
as of December 31, 2023

MI	1255	Arntson, Eric	120 S. Dexter Street, Suite 100	Ionia	48846	(616) 755-6800
MI	1256	McMullen, Timothy Y.	5784 W. US Highway 10	Ludington	49431	(231) 480-6777
MI	1258	Jacobs, Jeffrey A.	311 N. 7th Street	Grand Haven	49417	(616) 846-7650
MI	1259	Arntson, Eric	314 Baldwin Street	Jenison	49428	(616) 667-1100
MI	1260	Arntson, Eric	738 Michigan Avenue	Holland	49423	(616) 392-4556
MI	1261	Arntson, Eric	1335 Lake Drive SE	Grand Rapids	49506	(616) 774-2293
MI	1262	Arntson, Eric	3596 Clyde Park Avenue SW	Wyoming	49509	(616) 530-8080
MI	1263	Arntson, Eric	619 NW Leonard Street, Suite C	Grand Rapids	49504	(616) 791-2333
MI	1270	Jacobs, Jeffrey A.	1332 E. Apple Avenue	Muskegon	49442	(231) 777-3966
MI	1271	Lambert, Adam K.	650 N. Ripley Boulevard	Alpena	49707	(989) 394-6700
MI	1272	Jacobs, Jeffrey A.	3275 Henry Street	Muskegon	49441	(231) 759-0925
MI	1275	Lambert, Adam K.	1060 W. Main Street	Gaylord	49735	(989) 402-2400
MI	1276	Jacobs, Jeffrey A.	6022 Harvey Street	Muskegon	49444	(231) 798-3333
MI	1278	Mueller, Glenn A.	2706 W. Michigan Avenue	Kalamazoo	49006	(269) 343-3030
MI	1279	McMullen, Timothy Y.	206 Cypress Street	Manistee	49660	(231) 794-2772
MI	1280	Lambert, Adam K.	641 W. Washington Street	Marquette	49855	(906) 228-4630
MI	1283	Lambert, Adam K.	2313 Ludington Street	Escanaba	49829	(906) 789-0222
MI	1286	Lambert, Adam K.	1200 S. Stephenson Avenue	Iron Mountain	49801	(906) 205-2000
MI	1288	Mueller, Glenn A.	1788 W. Milham Avenue	Portage	49024	(269) 373-3030
MI	1292	Dally, Jason	1226 W. 14 Mile Road	Clawson	48017	(248) 621-2601
MI	1293	Arntson, Eric	328 Lansing Road, Suite A	Charlotte	48813	(517) 652-0424
MI	1294	Dolkowski, Aaron	37298 Six Mile Road	Livonia	48152	(734) 245-9414
MI	1295	Arntson, Eric	2545 Capital Avenue SW	Battle Creek	49015	(269) 589-6612
MI	1297	Sack, Lamine	10437 West McNichols Road	Detroit	48221	(313) 340-9452
MN	1900	Johnson, Corey L.	22413 MN-6	Deerwood	56444	(218) 622-0030
MN	1901	Graves, Susan L.	215 Oak Street SE	Minneapolis	55414	(612) 331-3030
MN	1903	Miller, David V.	5805 Egan Drive	Savage	55378	(952) 447-0030
MN	1904	Graves, Susan L.	2720 Winnetka Avenue N.	New Hope	55427	(763) 541-0030
MN	1905	Giefer, David A.	2256 Bunker Lake Boulevard N.W.	Andover	55304	(763) 767-0828
MN	1907	Peterson, Wayne A.	4540 Shady Oak Road	Minnetonka	55343	(952) 935-3030
MN	1908	Graves, Susan L.	1901 Johnson Street NE	Minneapolis	55418	(612) 789-0030
MN	1909	Graves, Susan L.	1517 White Bear Avenue N	St. Paul	55106	(651) 772-3030
MN	1910	Graves, Susan L.	2133 Old Hudson Road, Suite B	St. Paul	55119	(651) 735-3030
MN	1911	Graves, Susan L.	1014 Smith Avenue S.	West St. Paul	55118	(651) 457-3030
MN	1912	Graves, Susan L.	975 Grand Avenue	St. Paul	55105	(651) 224-3030
MN	1913	Graves, Susan L.	10495 University Avenue NE	Minneapolis	55434	(763) 757-3030
MN	1914	Graves, Susan L.	1231 Pierce Butler Route	St. Paul	55104	(651) 644-3030

Exhibit B Traditional
as of December 31, 2023

MN	1915	Hawkins, Ryan G.	117 Downtown Plaza	Fairmont	56031	(507) 229-0000
MN	1916	Hawkins, Ryan G.	1300 Humiston Avenue, Suite 300	Worthington	56187	(507) 350-3333
MN	1917	Krueger, Joel G.	4701 Clark Avenue	White Bear Lake	55110	(651) 429-9192
MN	1918	Graves, Susan L.	1113 Hennepin Avenue	Minneapolis	55403	(612) 338-3030
MN	1919	Peterson, Wayne A.	10904 Greenbrier Road	Minnetonka	55305	(952) 545-4669
MN	1920	Peterson, Wayne A.	4735 Hiawatha Avenue	Minneapolis	55406	(612) 729-8388
MN	1921	Graves, Susan L.	9723 Lyndale Avenue South	Bloomington	55420	(952) 888-4442
MN	1922	Graves, Susan L.	427 American Boulevard E.	Bloomington	55420	(952) 888-6661
MN	1923	Graves, Susan L.	5957 Penn Avenue South	Minneapolis	55419	(612) 920-7171
MN	1924	Graves, Susan L.	5551 W. Lake Street	St Louis Park	55416	(952) 926-5422
MN	1926	Graves, Susan L.	10700 Bloomington Ferry Road	Bloomington	55438	(952) 944-9244
MN	1927	Graves, Susan L.	5125 Edina Industrial Boulevard	Edina	55439	(952) 944-2463
MN	1928	Pierson, Jeffrey L.	224 E. 1st Avenue E	Shakopee	55379	(952) 445-9200
MN	1929	Graves, Susan L.	1681 Rice Street	Roseville	55113	(612) 800-9666
MN	1930	Miller, David V.	13756 Nicollette Avenue South	Burnsville	55337	(952) 890-4940
MN	1931	Peterson, Wayne A.	23500 Highway 7 Shorewood	Excelsior	55331	(612) 800-9703
MN	1932	Graves, Susan L.	935 37th Avenue, Suite 112	Moorhead	56560	(218) 331-6016
MN	1933	Miller, David V.	5480 141st Street W. #150	Apple Valley	55124	(952) 423-2424
MN	1934	Graves, Susan L.	635 Snelling Avenue South	St. Paul	55116	(651) 698-3030
MN	1935	Peterson, Wayne A.	7145 E. Pointe Douglas Road	Cottage Grove	55016	(651) 459-7663
MN	1936	Pierson, Jeffrey L.	13993 Anderson Lakes Parkway	Eden Prairie	55344	(952) 949-3030
MN	1937	Graves, Susan L.	1115 Vicksburg Lane #3	Plymouth	55447	(763) 404-9191
MN	1938	Marti, Jeanne M.	2350 7th Avenue	Anoka	55303	(763) 427-0120
MN	1939	Peterson, Wayne A.	1975 Silver Bell Road	Eagan	55122	(651) 454-0787
MN	1940	Cerna, Luis X.	1201 Gilmore Avenue	Winona	55987	(507) 454-4545
MN	1941	Gritz, Paul M.	4125 E. Frontage Road Highway 52 N.	Rochester	55901	(507) 282-3030
MN	1942	Gritz, Paul M.	444 3rd Avenue SE	Rochester	55904	(507) 288-3030
MN	1943	Krueger, Joel G.	221 Mineral Springs Road	Owatonna	55060	(507) 451-3030
MN	1944	Graves, Susan L.	2620 Rice Street	Little Canada	55113	(651) 483-3030
MN	1945	Graves, Susan L.	4552 Bloomington Avenue S.	Minneapolis	55407	(612) 823-3030
MN	1946	Graves, Susan L.	242 W. 7th Street	St. Paul	55102	(651) 227-3030
MN	1947	Graves, Susan L.	2441 Hennepin Avenue	Minneapolis	55405	(612) 374-3030
MN	1948	Nordberg, David C.	2418 Margaret Street	N. St. Paul	55109	(651) 777-3030
MN	1949	Graves, Susan L.	1090 Shingle Creek Parkway	Brooklyn Center	55430	(612) 521-9494
MN	1950	Peterson, Wayne A.	300 Stadium Road	Mankato	56001	(507) 625-7711
MN	1951	Peterson, Wayne A.	814 N. Riverfront Drive	Mankato	56001	(507) 625-3666
MN	1952	Peterson, Wayne A.	103 S. Minnesota Avenue	St. Peter	56082	(507) 934-9112

Exhibit B Traditional
as of December 31, 2023

MN	1953	Peterson, Wayne A.	315 N Minnesota Street	New Ulm	56073	(507) 359-7711
MN	1954	Graves, Susan L.	5164 Central Avenue NE	Columbia Heights	55421	(763) 571-4240
MN	1955	Peterson, Wayne A.	5863 Neal Avenue N.	Oak Park Hts.	55082	(651) 430-3030
MN	1956	Graves, Susan L.	1406 E. College Drive	Marshall	56258	(507) 532-3030
MN	1957	Miller, David V.	629 4th Street NW	Farbault	55021	(507) 334-3954
MN	1958	Gritz, Paul M.	910 S. Broadway	Albert Lea	56007	(507) 373-3331
MN	1959	Gritz, Paul M.	106 S. Main Street	Austin	55912	(507) 437-3030
MN	1960	Graves, Susan L.	616 2nd Street S.	St. Cloud	56301	(320) 259-1900
MN	1961	Graves, Susan L.	202 2nd Avenue N.	Sauk Rapids	56379	(320) 251-4885
MN	1962	Graves, Susan L.	130 Gateway Drive NE	East Grand Forks	56721	(218) 773-2121
MN	1963	Radke, Janet L.	107 S. State Street	Waseca	56093	(507) 833-8888
MN	1964	Johnson, Corey L.	7295 Glory Road	Baxter	56425	(218) 297-3030
MN	1965	Herklotz, Skip Emory	202 5th Street N.	Waverly	55390	(763) 658-4916
MN	1966	Graves, Susan L.	3900 Vinewood Lane N. #23	Plymouth	55441	(763) 557-9999
MN	1967	Peterson, Wayne A.	103 W. 23rd Street	Hastings	55033	(651) 437-3930
MN	1968	Miller, David V.	4995 160th Street SE, Suite 500	Prior Lake	55372	(952) 440-3030
MN	1969	Giefler, David A.	726 Martin Avenue, Suite 106	Big Lake	55309	(763) 247-8880
MN	1970	Miller, David V.	110 E 4th Street	Northfield	55057	(507) 663-1221
MN	1971	Krueger, Joel G.	2548 Highway 10 NE	Mounds View	55112	(763) 786-2383
MN	1972	Johnson, Corey L.	24400 Smiley Road, Unit 5 & 6	Nisswa	56468	(218) 963-5100
MN	1973	Graves, Susan L.	503 N. Chestnut Street	Chaska	55318	(952) 448-4408
MN	1974	Graves, Susan L.	5309 Shoreline Drive	Mound	55364	(952) 472-3030
MN	1975	Graves, Susan L.	6635 Cahill Avenue	Inver Grove Heights	55076	(651) 455-5064
MN	1976	Peterson, Wayne A.	400 W. 78th Street	Chanhassen	55317	(952) 934-6878
MN	1977	Carlson, Duane L. Jr.	625 7th Avenue	Two Harbors	55616	(218) 510-0696
MN	1979	Graves, Susan L.	601 N. Broadway	Crookston	56716	(218) 281-3671
MN	1980	Miller, David V.	14875 S. Robert Trail	Rosemount	55068	(651) 423-6090
MN	1981	Graves, Susan L.	209 Brooks Avenue N.	Thief River Falls	56701	(218) 681-6000
MN	1982	Carlson, Duane L. Jr.	1303 Charles Street	Park Rapids	56470	(218) 237-3344
MN	1983	Graves, Susan L.	126 W. Cavour Avenue	Fergus Falls	56537	(218) 736-5411
MN	1984	Carlson, Duane L. Jr.	2518 E. Bellline	Hibbing	55746	(218) 262-6695
MN	1985	Carlson, Duane L. Jr.	112 E. 2nd Street	Duluth	55805	(218) 722-3030
MN	1986	Carlson, Duane L. Jr.	1701 Woodland Avenue	Duluth	55803	(218) 728-3627
MN	1987	Carlson, Duane L. Jr.	1212 Cloquet Avenue	Cloquet	55720	(218) 499-0099
MN	1988	Graves, Susan L.	355 Willow Bend	Crystal	55428	(763) 535-6313
MN	1989	Nordberg, David C.	132 N. Lake Street	Forest Lake	55025	(651) 464-7080
MN	1990	Graves, Susan L.	602 1st Street S, Suite 1	Willmar	56201	(320) 235-3030

Exhibit B Traditional
as of December 31, 2023

MN	1991	Wendolek, Pete J.	111 South Main Street	Hutchinson	55350	(320) 587-7070
MN	1992	Cole, Shane A.	107 2nd Street NE	Little Falls	56345	(320) 632-2371
MN	1993	Peterson, Wayne A.	17823 Kenwood Trail	Lakeville	55044	(952) 892-1212
MN	1994	Carlson, Duane L. Jr.	1200 S. Pokegama Avenue, Suite 80	Grand Rapids	55744	(218) 326-9444
MN	1995	Johnson, Corey L.	413 W. Washington, Unit C	Brainerd	56401	(218) 828-5066
MN	1997	Krueger, Joel G.	12925 Lake Boulevard	Lindstrom	55045	(651) 257-2002
MN	7300	Krueger, Joel G.	1058 Enterprise Drive	Belle Plaine	56011	(952) 873-2020
MN	7309	Krueger, Joel G.	1210 County Road J East, Suite 102	White Bear Township	55127	(651) 390-7500
MN	7319	Gritz, Paul M.	501 S. Mantorville Avenue	Kasson	55944	(507) 634-3344
MN	7323	Graves, Susan L.	9322 Zane Avenue North	Brooklyn Park	55443	(763) 391-0909
MN	7338	Nordberg, David C.	5862 Oak Street	North Branch	55056	(651) 277-3030
MN	7339	Johnson, Corey L.	114 Rum River Drive S	Princeton	55371	(763) 389-8900
MN	7342	Giefler, David A.	17565 Highway 65 NE	Ham Lake	55304	(763) 434-4300
MN	7343	Krueger, Joel G.	107 Wildwood Road	Willemie	55090	(651) 429-4252
MN	7344	Giefler, David A.	211 Elm Street West, Suite 200	Annandale	55302	(320) 270-6200
MN	7345	Peterson, Wayne A.	3019-A South Service Drive	Red Wing	55066	(651) 388-0444
MN	7347	Giefler, David A.	112 W. Broadway	Monticello	55362	(763) 295-2424
MN	7348	Peterson, Wayne A.	1266 Town Centre Drive	Egan	55123	(651) 452-3030
MN	7349	Graves, Susan L.	783 Radio Drive #108	Woodbury	55125	(651) 738-3030
MN	7350	Graves, Susan L.	18157 Carson Court NW, Suite F	Elk River	55330	(763) 441-6500
MN	7352	Gellately, Dana M.	701 Paul Bunyan Drive NW	Bemidji	56601	(218) 759-3030
MN	7353	Graves, Susan L.	5801 Ridgewood Road, Suite 3	St. Cloud	56303	(320) 253-8520
MN	7354	Krueger, Joel G.	3551 Lexington Avenue N	Arden Hills	55126	(651) 484-3030
MN	7355	Graves, Susan L.	525 Main Street	New Brighton	55112	(651) 638-3030
MN	7356	Graves, Susan L.	505 Broadway Street	Alexandria	56308	(320) 763-5007
MN	7357	Graves, Susan L.	13590 Grove Drive	Maple Grove	55311	(763) 420-8988
MN	7358	Giefler, David A.	1524 125th Avenue NE	Blaine	55449	(763) 755-3030
MN	7360	Johnson, Corey L.	6014 167th Avenue N.W.	Ramsey	55303	(763) 753-3200
MN	7361	Peterson, Wayne A.	18350 Pilot Knob Road, Suite C	Farmington	55024	(651) 463-3030
MN	7362	Carlson, Duane L. Jr.	308 Chestnut Street	Virginia	55792	(218) 741-3030
MN	7363	Carlson, Duane L. Jr.	32 E. Sheridan Street	Ely	55731	(218) 235-6262
MN	7365	Graves, Susan L.	9370 Lexington Avenue NE, Bay 10	Circle Pines	55014	(763) 786-7864
MN	7366	Johnson, Corey L.	1302 Washington Avenue	Detroit Lakes	56501	(218) 846-1502
MN	7367	Herdklotz, Skip Emory	1865 W. Wayzata Boulevard	Long Lake	55356	(952) 473-0400
MN	7368	Carlson, Eric Michael	309 N Central Ave	Duluth	55807	(218) 628-3030
MN	7369	Johnson, Corey L.	1595 2nd Avenue NW., Suite 130	Cambridge	55008	(763) 689-5603
MN	7371	Graves, Susan L.	3260 Brookdale Drive N.	Brooklyn Park	55443	(763) 566-3030

Exhibit B Traditional
as of December 31, 2023

MN	7372	Graves, Susan L.	1011 Robert Street South	West St. Paul	55118	(612) 361-1998
MN	7374	Graves, Susan L.	232 W. 1st Street	Waconia	55387	(952) 442-9780
MN	7375	Giefer, David A.	96 14th Street NE	Buffalo	55313	(763) 682-3830
MN	7376	Herklotz, Skip Emory	8060 Highway 55, Suite 55	Rockford	55373	(763) 477-4443
MN	7378	Graves, Susan L.	1530 1st Avenue North	Moorehead	56560	(218) 233-2211
MN	7379	Krueger, Joel G.	27 East Central	St. Michael	55376	(763) 497-4848
MN	7380	Carlson, Duane L. Jr.	1623 2nd Avenue W.	International Falls	56649	(218) 283-3444
MN	7381	Graves, Susan L.	13625 Northdale Boulevard, Suite 2	Rogers	55374	(763) 428-8333
MN	7382	Giefer, David A.	23168 Street Francis Boulevard NW	St. Francis	55070	(763) 753-4300
MN	7384	Giefer, David A.	25928 2nd Street E.	Zimmerman	55398	(763) 856-0333
MN	7385	Giefer, David A.	13848 First Street, SE	Becker	55308	(763) 220-8600
MN	7386	Krueger, Joel G.	14531 Forest Boulevard	Hugo	55038	(651) 426-3030
MN	7387	Carlson, Duane L. Jr.	4960 Miller Trunk Highway	Duluth	55811	(218) 729-7979
MN	7388	Krueger, Joel G.	106 E. Main Street	New Prague	56071	(952) 758-8833
MN	7396	Krueger, Joel G.	10 Church Street	Elko New Market	55054	(952) 461-4614
MN	9731	Gritz, Paul M.	2025 S. Broadway Avenue	Rochester	55904	(507) 361-3030
MO	1500	Williams, Craig K.	17404 E. US Highway 24	Independence	64056	(816) 601-2020
MO	1501	McGowan, Benjamin Aaron	623 South Maguire Street	Warrensburg	64093	(660) 429-2171
MO	1502	Ratterman, Mark B.	416 S. Ninth Street	Columbia	65201	(573) 875-3030
MO	1503	Ratterman, Mark B.	1500 I-70 Drive S.W., Suite #6	Columbia	65201	(573) 875-1010
MO	1504	Ratterman, Mark B.	102 W 6th Street	Fulton	65251	(573) 642-0991
MO	1505	Ratterman, Mark B.	1621-A Towne Drive	Columbia	65202	(573) 474-9565
MO	1506	Ratterman, Mark B.	2148 Mckelvey Road	Maryland Heights	63043	(314) 878-1111
MO	1507	Fischer, Douglas Mark	12200 15th Street, Suite 110	Grandview	64030	(816) 318-7600
MO	1508	Palmer, Steven T.	1006 South Main Street	Maryville	64468	(660) 562-2800
MO	1509	Naugle, Leonard J.	1109 S. Baltimore Street	Kirksville	63501	(660) 627-3030
MO	1510	Ratterman, Mark B.	11240 Manchester Road	Kirkwood	63122	(314) 966-3030
MO	1511	Ratterman, Mark B.	345 Clarkson Road	Ellisville	63011	(636) 391-6600
MO	1512	Palmer, Steven T.	192 W. 92 Highway	Kearney	64060	(816) 866-8025
MO	1514	Palmer, Steven T.	9008 NW MO-45	Parkville	64152	(816) 601-3030
MO	1515	Naugle, Leonard J.	1100 N. Morley, Suite D	Moberly	65270	(660) 269-9988
MO	1516	Ratterman, Mark B.	4167 North Street Peters Parkway	St. Peters	63304	(636) 447-7070
MO	1517	Ratterman, Mark B.	9432 Natural Bridge Road	Berkeley	63134	(314) 426-3113
MO	1518	Naugle, Leonard J.	827 W. Monroe Street	Mexico	65265	(573) 581-4811
MO	1519	Holloway, Shane G.	1152 Ransom Road	West Plains	65775	(417) 257-0055
MO	1520	Bumpus, David M.	2370 East Main Street	Jackson	63755	(573) 243-1474
MO	1522	Ratterman, Mark B.	5201 S. Grand Boulevard	St. Louis	63111	(314) 352-1400

Exhibit B Traditional
as of December 31, 2023

MO	1523	Black, Eric Robert	3732 W. Truman Boulevard	Jefferson City	65109	(573) 893-2400
MO	1524	Ratterman, Mark B.	1613 S 9th Street	St Louis	63104	(314) 621-3030
MO	1525	Black, Eric Robert	1717 Christy Drive	Jefferson City	65101	(573) 634-8444
MO	1526	Ratterman, Mark B.	5421 Chippewa Street	St Louis	63109	(314) 832-4555
MO	1527	Ratterman, Mark B.	3930 Lindell Boulevard	St. Louis	63108	(314) 652-3030
MO	1529	Ratterman, Mark B.	2554 Gladiator Drive	Fenton	63026	(636) 825-1919
MO	1530	Elwell, Emily E.	6015 N Main Street	Webb City	64870	(417) 614-0707
MO	1532	Elwell, Emily E.	908 West Harmony Street	Neosho	64850	(417) 658-4750
MO	1534	Williams, Craig K.	451 SW Eagles Parkway	Grain Valley	64029	(816) 535-1500
MO	1535	Williams, Craig K.	706 NW 7 Highway, Suite E	Blue Springs	64014	(816) 228-2700
MO	1536	Dixon, Katherine A	700 E. North Avenue	Belton	64012	(816) 331-5100
MO	1537	Ratterman, Mark B.	1271 Main Street	Imperial	63052	(636) 467-9339
MO	1538	Wampler, Stephen E.	615 N. A Street	Farmington	63640	(573) 756-8966
MO	1540	Elwell, Emily E.	1714 S. Range Line Road	Joplin	64804	(417) 624-3460
MO	1542	Elwell, Emily E.	1701 W. 7th Street	Joplin	64801	(417) 623-5211
MO	1543	Black, Eric Robert	1800 Bagnell Dam Boulevard	Lake Ozark	65049	(573) 693-1234
MO	1544	Fischer, Douglas Mark	534 Westport Road	Kansas City	64111	(816) 756-3910
MO	1545	Black, Eric Robert	213 Street Robert Boulevard	St. Robert	65584	(573) 336-3400
MO	1546	Black, Eric Robert	1732 N. Bishop Avenue, Suite B	Rolla	65401	(573) 364-7110
MO	1547	Black, Eric Robert	1816 S. Jefferson Avenue	Lebanon	65536	(417) 588-7070
MO	1548	Bumpus, David M.	612 North One Mile Road	Dexter	63841	(573) 614-7848
MO	1549	McGowan, Benjamin Aaron	3200-A S. Limit Avenue	Sedalia	65301	(660) 829-3030
MO	1550	Hurteau/Prather, Art/Marty	538 S. National Avenue	Springfield	65802	(417) 831-1110
MO	1551	Hurteau/Prather, Art/Marty	1241 E. Kearney Street	Springfield	65803	(417) 863-0044
MO	1552	Hurteau/Prather, Art/Marty	4021 S. Campbell Avenue	Springfield	65807	(417) 889-3131
MO	1553	Hurteau/Prather, Art/Marty	2565 E. Sunshine Street	Springfield	65804	(417) 889-2323
MO	1554	Hurteau/Prather, Art/Marty	2642 W. Sunshine Street	Springfield	65807	(417) 522-3322
MO	1555	Hurteau/Prather, Art/Marty	3308 W. Chestnut Expressway	Springfield	65802	(417) 522-4499
MO	1556	Naugle, Leonard J.	408 US Highway 50 West	Union	63084	(636) 583-3020
MO	1557	Hurteau/Prather, Art/Marty	1045 Spur Drive	Marshfield	65706	(417) 943-2400
MO	1558	McGowan, Benjamin Aaron	1307 Washington Street	Chillicothe	64601	(660) 646-9800
MO	1559	Naugle, Leonard J.	326 E. Fifth Street	Washington	63090	(636) 239-1515
MO	1560	Ratterman, Mark B.	9511 Lackland Road	St Louis	65802	(314) 423-7440
MO	1561	Ratterman, Mark B.	11124 Old Street Charles Road	St. Ann	63074	(314) 291-3334
MO	1562	Ratterman, Mark B.	14764 Clayton Road	Ballwin	63011	(636) 391-6304
MO	1563	Ratterman, Mark B.	667 Big Bend Road	Ballwin	63021	(636) 227-6300
MO	1564	Ratterman, Mark B.	9620 Olive Boulevard	Olivette	63132	(314) 432-2530

Exhibit B Traditional
as of December 31, 2023

MO	1565	Burch, Nicholas M.	1028 N. Sprigg Street	Cape Girardeau	63701	(573) 651-3880
MO	1566	Bumpus, David M.	530 S. Main Street	Sikeston	63801	(573) 471-2667
MO	1567	Bumpus, David M.	2205 N. Westwood Boulevard	Poplar Bluff	63901	(573) 686-7291
MO	1568	Ratterman, Mark B.	1951 Richardson Road	Arnold	63010	(636) 467-5800
MO	1569	Ratterman, Mark B.	801 Collins Drive, Suite B	Festus	63028	(636) 933-0707
MO	1570	Ratterman, Mark B.	2181 Droste Road	Saint Charles	63301	(636) 723-0150
MO	1571	Ratterman, Mark B.	500 W. Pearce Boulevard	Wentzville	63385	(636) 327-7999
MO	1572	Miller, Daryl M.	2110 Messanie Street	St. Joseph	64507	(816) 232-6060
MO	1574	Ratterman, Mark B.	2711 High Ridge Boulevard	High Ridge	63049	(636) 677-2522
MO	1575	Ratterman, Mark B.	8426 N. Linbergh Boulevard	Florissant	63031	(314) 838-5757
MO	1576	Ratterman, Mark B.	2500 N Highway 67	Florissant	63033	(314) 831-5454
MO	1577	Ratterman, Mark B.	309-A Mid Rivers Mall Drive	Saint Peters	63376	(636) 278-6626
MO	1578	Ratterman, Mark B.	13214 Tesson Ferry Road	St. Louis	63128	(314) 843-0909
MO	1579	Mabrey, Jeffrey M.	4315 McMasters Avenue	Hannibal	63401	(573) 221-2861
MO	1580	Ratterman, Mark B.	7259 Manchester Road	Maplewood	63143	(314) 644-6700
MO	1581	Hurteau/Prather, Art/Marty	407 E. Walnut Lane	Willard	65781	(417) 685-1515
MO	1582	Ratterman, Mark B.	8544 Watson Road	St. Louis	63119	(314) 843-5353
MO	1583	Ratterman, Mark B.	3239 A Lemay Ferry Road	St. Louis	63125	(314) 487-9190
MO	1584	Ratterman, Mark B.	485 S. Kirkwood Road, Suite 105 D	Kirkwood	63122	(314) 821-4111
MO	1585	Ratterman, Mark B.	4551 Telegraph Road	Oakville	63129	(314) 846-6600
MO	1586	Ratterman, Mark B.	9605 Manchester Road	Rock Hill	63119	(314) 961-7800
MO	1587	Ratterman, Mark B.	7018 Pershing	University City	63130	(314) 726-3030
MO	1588	Ratterman, Mark B.	12317 Old Halls Ferry Road	Black Jack	63033	(314) 741-5280
MO	1589	Ratterman, Mark B.	7240 Natural Bridge Road	Normandy	63121	(314) 389-3030
MO	1590	Dixon, Katherine A	309 South Commercial Street	Harrisonville	64701	(816) 793-6333
MO	1591	Ratterman, Mark B.	10109 Lewis & Clark Boulevard	St. Louis	63136	(314) 868-2244
MO	1592	Elwell, Emily E.	100 Chapel Drive, Suite H	Monett	65708	(417) 393-1776
MO	1593	Ratterman, Mark B.	6963 Olive Boulevard	University	63130	(314) 862-3030
MO	1594	Ratterman, Mark B.	10486 West Florissant Avenue	Dellwood	63136	(314) 521-7335
MO	1600	Black, Eric Robert	5531 Osage Beach Parkway	Osage Beach	65065	(573) 302-4888
MO	1601	Hurteau/Prather, Art/Marty	3310 W. 76 Country Boulevard, Ste A-B	Branson	65616	(417) 335-6789
MO	1602	Ratterman, Mark B.	11933 Olive Boulevard	Creve Coeur	63141	(314) 567-1010
MO	1603	Ratterman, Mark B.	8814 Gravois Road	Affton	63123	(314) 631-2100
MO	1604	Carlson, J. Bradley	795 NE Rice Road	Lee's Summit	64086	(816) 525-2244
MO	1605	Ratterman, Mark B.	1430 N. 13th	St. Louis	63106	(314) 421-3030
MO	1606	McGowan, Benjamin Aaron	819 S. Cherokee Drive, Suite #2	Marshall	65340	(660) 886-6565
MO	1607	Ratterman, Mark B.	2256 S Grand Boulevard	St. Louis	63104	(314) 773-4404

Exhibit B Traditional
as of December 31, 2023

MO	1608	Ratterman, Mark B.	13728 Olive Boulevard	Chesterfield	63017	(314) 275-7979
MO	1610	Fischer, Douglas Mark	2516 NE 43rd Street	Kansas City	64116	(816) 454-3363
MO	1611	Ratterman, Mark B.	8760 Veterans Memorial Parkway	O'Fallon	63366	(636) 281-3030
MO	1612	Wampler, Stephen E.	12 E. Main Street	Park Hills	63601	(573) 431-7372
MO	1613	Ratterman, Mark B.	10736 Business Route 21	Hillsboro	63050	(636) 797-8520
MO	1615	McGowan, Benjamin Aaron	121 N. Service Road W	Sullivan	63080	(573) 468-3030
MO	1616	Ratterman, Mark B.	12501 Natural Bridge Road	Bridgeton	63044	(314) 291-3232
MO	1617	Burch, Nicholas M.	1420 N. Kingshighway Street	Cape Girardeau	63701	(573) 334-9988
MO	1618	Ratterman, Mark B.	1966 S. Old Highway 94	St. Charles	63303	(636) 724-6060
MO	1619	Ratterman, Mark B.	3104 Greens Meadow Way	Columbia	65203	(573) 443-3030
MO	1620	Palmer, Steven T.	15700 N US 169 Highway, Unit C	Smithville	64089	(816) 287-2424
MO	1621	Ratterman, Mark B.	1444 N. Kings Highway Boulevard	St. Louis	63113	(314) 454-3030
MO	1622	Ratterman, Mark B.	2128 Rock Road	De Soto	63020	(636) 586-4949
MO	1624	Ratterman, Mark B.	1655 South Highway 141	Fenton	63026	(636) 349-3338
MO	1625	Hurteau/Prather, Art/Marty	491 Highway 60 East	Republic	65738	(417) 732-4242
MO	1626	Bumpus, David M.	1219 Rand Avenue	Perryville	63775	(573) 547-3030
MO	1627	Williams, Craig K.	3709-B S. Noland Road	Independence	64055	(816) 373-3734
MO	1628	Palmer, Steven T.	7759 NW Prairie View Road	Kansas City	64151	(816) 741-1900
MO	1629	Ratterman, Mark B.	32 Pevely Plaza	Pevely	63070	(636) 479-3311
MO	1630	Hurteau/Prather, Art/Marty	411 A Northview Road	Nixa	65714	(417) 724-1010
MO	1631	Wampler, Stephen E.	836 East High Street #8	Potosi	63664	(573) 438-7422
MO	1632	Palmer, Steven T.	118 Conistor, Suite C	Liberty	64068	(816) 415-9400
MO	1633	Wampler, Stephen E.	940A Plaza Drive	St. Clair	63077	(636) 629-2929
MO	1634	Black, Eric Robert	16 Camden Court, SE	Camdenton	65020	(573) 410-8100
MO	1635	McGowan, Benjamin Aaron	2240 W. Osage Street	Pacific	63069	(636) 257-3030
MO	1636	McGowan, Benjamin Aaron	275 West North Servie Road, Suite H	Wright City	63390	(636) 791-0411
MO	1639	Hurteau/Prather, Art/Marty	1411 W. Highway J	Ozark	65721	(417) 581-7070
MO	1640	Ratterman, Mark B.	105 Long Road	Chesterfield	63005	(636) 537-3223
MO	1641	Ratterman, Mark B.	3441 Pheasant Point	O'Fallon	63366	(636) 281-5500
MO	1642	Wampler, Stephen E.	201 East College	Fredericktown	63645	(573) 783-7999
MO	1643	McGowan, Benjamin Aaron	307 W. Highway 28	Owensville	65066	(573) 437-8777
MO	1644	Elwell, Emily E.	1208 S. Elliot Avenue	Aurora	65605	(417) 308-8833
MO	1645	Hurteau/Prather, Art/Marty	623 S. Springfield Avenue	Bolivar	65613	(417) 777-7070
MO	1646	Elwell, Emily E.	2003 S. Garrison Avenue	Carthage	64836	(417) 358-6565
MO	1647	Hurteau/Prather, Art/Marty	530 N. Eastgate Avenue	Springfield	65804	(417) 522-2330
MO	1649	McGowan, Benjamin Aaron	107-C Hilltop Village Shopping Center	Eureka	63025	(636) 938-3320
MO	1677	Wampler, Stephen E.	40 Plaza Drive	Sainte Genevieve	63670	(573) 883-9959

Exhibit B Traditional
as of December 31, 2023

MO	1678	Elwell, Emily E.	200 W. Austin	Nevada	64772	(417) 667-8878
MO	1679	McGowan, Benjamin Aaron	1331 Northeast Service Road, Suite 5	Warrenton	63383	(636) 456-8444
MO	1680	Williams, Craig K.	11120 E US Hwy 24	Sugar Creek	64054	(816) 368-8600
MO	1682	McGowan, Benjamin Aaron	902 South Sturgeon Street	Montgomery City	63361	(573) 564-1900
MO	1684	Dixon, Katherine A	3544 SW Market Street	Lee's Summit	64082	(816) 683-7500
MO	1685	Elwell, Emily E.	624 S. Madison	Webb City	64870	(417) 673-8900
MO	1686	Holloway, Shane G.	100 W. 17th Street, Suite A	Mountain Grove	65711	(417) 926-1100
MO	1687	Hurteau/Prather, Art/Marty	876 Birch Street	Hollister	65672	(417) 337-7788
MO	1688	Ratterman, Mark B.	131 North Lincoln Drive	Troy	63379	(636) 528-3520
MO	1689	Black, Eric Robert	203 N. Henry Clay Boulevard	Ashland	65010	(573) 415-0000
MO	1690	Wampler, Stephen E.	48 Berry Road	Bonne Terre	63628	(573) 358-3322
MO	1691	Dixon, Katherine A	4201A East Blue Parkway	Kansas City	64130	(816) 923-1007
MO	1694	Fischer, Douglas Mark	7208 Wornall Road, Suite A	Kansas City	64114	(816) 237-1888
MO	1695	Williams, Craig K.	9103 E. Highway 350	Raytown	64133	(816) 886-0350
MO	1696	Hurteau/Prather, Art/Marty	1431 W. South Street	Ozark	65721	(417) 681-5090
MO	2393	Wampler, Stephen E.	105 S. Main Street	Salem	65560	(573) 453-2999
MO	2818	Ratterman, Mark B.	1620 Shackelford	Florissant	63031	(314) 924-9800
MO	6373	Palmer, Steven T.	9324 N. Oak Trafficway	Kansas City	64155	(816) 420-8220
MO	9571	Fischer, Douglas Mark	531 Grand Avenue, Suite 4	Kansas City	64016	(816) 586-0044
MO	9572	Palmer, Steven T.	13131 State Line Road	Kansas City	64145	(816) 306-0033
MO	9573	Palmer, Steven T.	7302 North Oak Trafficway	Gladstone	64118	(816) 759-8558
MO	9574	Turner, Ty Michael	630 Cottonwood Plaza	Kennett	63857	(573) 559-1600
MO	9575	Ratterman, Mark B.	149 Pond Fort Trail	Lake St. Louis	63367	(636) 695-8500
MO	9576	Miller, Daryl M.	2223 North Belt Highway	St. Joseph	64506	(816) 232-1010
MO	9577	Hurteau/Prather, Art/Marty	4032 W. Republic Road	Battlefield	65619	(417) 633-7525
MS	1521	Shifflett, Juan Jason	11201 Old Goodman Road, Suite 500	Olive Branch	38654	(662) 273-0303
MS	3217	Brown, Timothy Brett	700-A N. Main Street	Amory	38821	(662) 256-3663
MS	5901	Mueller, Glenn A.	1681 Pass Road	Biloxi	39531	(228) 374-7234
MS	5902	Mueller, Glenn A.	10493 D'Iberville Boulevard	D'Iberville	39540	(228) 392-6636
MS	5903	Mueller, Glenn A.	2260 Bienville Boulevard	Ocean Springs	39564	(228) 872-3030
MS	5905	Mueller, Glenn A.	2310 Denny Avenue	Pascagoula	39567	(228) 769-9700
MS	5907	Mueller, Glenn A.	2591 Highway 90	Gautier	39553	(228) 497-4888
MS	5908	Mueller, Glenn A.	11236 Lorraine Road	Gulfport	39503	(228) 832-1111
MS	5909	Mueller, Glenn A.	8230 Tucker Road	Vancleave	39565	(228) 875-3030
MS	5910	Mueller, Glenn A.	1107 Cowan Road, Suite A	Gulfport	39507	(228) 868-6061
MS	5911	Mueller, Glenn A.	11380 Hwy 49 North	Gulfport	39503	(228) 831-3030
MS	5912	Mueller, Glenn A.	2712 25th Avenue	Gulfport	39501	(228) 575-3434

Exhibit B Traditional
as of December 31, 2023

MS	5913	Mueller, Glenn A.		501 Highway 90	Bay Saint Louis	39520	(228) 467-2020
MS	5914	Mueller, Glenn A.		19099 Pineville Road, Suite 110	Long Beach	39560	(228) 868-6600
MS	5916	Richards, John		2785 Highway 49 S, Suite E	Florence	39073	(601) 845-5030
MS	5917	Mueller, Glenn A.		917 Memorial Boulevard	Picayune	39466	(601) 798-7070
MS	5920	Richards, John		3203 Hardy Street	Hattiesburg	39401	(601) 264-2996
MS	5921	Richards, John		1272 Evelyn Gandy Parkway, Suite 10	Petal	39465	(601) 544-3030
MS	5922	Richards, John		6136 Highway 98 West, Suite 101	Hattiesburg	39402	(601) 268-1099
MS	5924	Magee, Matthew		975 Brookway Boulevard	Brookhaven	39601	(601) 835-3278
MS	5925	Richards, John		713 North 16th Avenue	Laurel	39440	(601) 649-0800
MS	5926	Mueller, Glenn A.		107B NE Interchange Street	Diamondhead	39525	(228) 255-0001
MS	5927	Richards, John		2535 N. Hill Street, Unit B	Meridian	39305	(601) 693-3030
MS	5928	Magee, Matthew		1515 Delaware Avenue	McComb	39648	(601) 684-6949
MS	5929	Richards, John		2145 Highway 18	Brandon	39042	(601) 825-5012
MS	5930	Yildirim, Molly Hilal		1303 Highway 35 South, Suite F	Forest	39074	(601) 564-0567
MS	5931	Richards, John		849 Lake Harbour Drive, Suite A	Ridgeland	39157	(601) 956-4900
MS	5932	Richards, John		5545 Robinson Road Extension	Jackson	39204	(601) 371-2300
MS	5933	Richards, John		118 S. Pearson Road	Pearl	39208	(601) 932-5882
MS	5934	Richards, John		909 Old Vicksburg Road, Suite B	Clinton	39056	(601) 924-3030
MS	5935	Richards, John		616 N. Jefferson Street	Jackson	39202	(601) 353-5600
MS	5936	Richards, John		4555 Office Park Drive	Jackson	39206	(601) 362-7777
MS	5939	Richards, John		5490 Castlewoods Ct., Suite F	Flowood	39232	(601) 992-3030
MS	5940	Yildirim, Molly Hilal		400 Highway 16 E.	Carthage	39051	(601) 654-2300
MS	5941	Brown, Timothy Brett		1920 & 1922 University Avenue	Oxford	38655	(662) 236-3844
MS	5942	Richards, John		7381 Siwell Road	Byram	39272	(601) 346-9737
MS	5943	Richards, John		956 Highway 51	Madison	39110	(601) 707-7803
MS	5944	Varela, Mario		201 Highway 82 W, Suite A	Indianola	38751	(662) 577-4122
MS	5945	Varela, Mario		1515 Highway 1 S #A	Greenville	38703	(662) 378-2091
MS	5946	Varela, Mario		919 Highway 82 West	Greenwood	38930	(662) 455-3030
MS	5949	Bergeron, Nicole M.		97 Northgate Road	Natchez	39120	(601) 445-6006
MS	5953	Magee, Matthew		725 Highway 61 South	Vicksburg	39180	(601) 636-3501
MS	5954	Richards, John		1091 Gluckstadt Road, Suite B	Madison	39110	(601) 898-2330
MS	5955	Brown, Timothy Brett		8046 Highway 51 North	Southaven	38671	(662) 342-4747
MS	5957	Brown, Timothy Brett		805 City Avenue South	Ripley	38663	(662) 576-0076
MS	5958	Brown, Timothy Brett		1510 Main Street	Columbus	39701	(662) 329-3131
MS	5960	Magee, Matthew		17145 West Wortham Road	Saucier	39574	(228) 687-9696
MS	5961	Shifflett, Juan Jason		5847 Getwell Road	Southaven	38672	(662) 349-3999
MS	5962	Richards, John		101 Highway 12	Starkville	39759	(662) 324-2100

Exhibit B Traditional
as of December 31, 2023

MS	5964	Dhedhi, Danish W.	1221 S Gloster Street	Tupelo	38801	(662) 841-0733
MS	5965	Brown, Timothy Brett	1303 Highway 8 #D	Grenada	38901	(662) 226-3833
MS	5967	Shifflett, Juan Jason	314 W Main Street	Senetobia	38668	(662) 562-9500
MS	5968	Megee, Matthew	7100 Highway 63	Moss Point	39563	(228) 474-9555
MS	5969	Yildirim, Molly Hilal	1150 E. Peace Street	Canton	39046	(601) 855-2433
MS	5970	Richards, John	902 W. Government Street	Brandon	39042	(601) 706-1577
MS	5971	Brown, Timothy Brett	1603 Jackson Avenue W	Oxford	38655	(662) 236-3840
MS	5972	Brown, Timothy Brett	460 Church Road E	Southaven	38671	(662) 536-3636
MS	5973	Megee, Matthew	925 Highway 98 Bypass	Columbia	39429	(601) 736-0773
MS	5974	Brown, Timothy Brett	236 Stariyn Avenue	New Albany	38652	(662) 538-0335
MS	5975	Davis, Curtis	640 Desoto Avenue	Clarksdale	38614	(662) 627-5030
MS	5976	Davis, Diane Ardine	460 Highway 6 E.	Batesville	38606	(662) 563-5600
MS	5978	Brown, Timothy Brett	327 Highway 45 South	West Point	39773	(662) 494-2000
MS	5979	Shifflett, Juan Jason	2334 McIngvale Road	Hemando	38632	(662) 449-3468
MS	5980	Shifflett, Juan Jason	8859 Goodman Road	Olive Branch	38654	(662) 895-3005
MS	5981	Cavaliere, Christopher L.	100 Canal Place	Philadelphia	39350	(601) 389-0500
MS	5982	Davis, Diane Ardine	5842 Goodman Road, Suite 13	Horn Lake	38637	(662) 781-2781
MS	5984	Megee, Matthew	800 Hill Street	Ellisville	39437	(601) 477-4949
MS	5985	Megee, Gregory S.	5157 East Main Street	Lucedale	39452	(601) 947-1636
MS	5986	Brown, Timothy Brett	116 Highway 15 N	Pontotoc	38863	(662) 489-3033
MS	5988	Megee, Gregory S.	1107 East Frontage Road, Suite E	Wiggins	39577	(601) 928-2727
MS	5989	Turner, Ty Michael	425-C North Davis Avenue	Cleveland	38732	(662) 843-3663
MS	5990	Megee, Matthew	5828 U.S. Highway 11	Purvis	39475	(601) 794-6660
MS	5992	Brown, Timothy Brett	1102 US Highway 75 East	Corinth	38834	(662) 284-9099
MS	5993	Brown, Timothy Brett	201 Wal-Mart Circle	Booneville	38829	(662) 728-7778
MS	5994	Brown, Timothy Brett	272 Whaley Avenue	Holly Springs	38635	(662) 252-5252
MS	5995	Dhedhi, Danish W.	3581 N Gloster Street, Suite C	Tupelo	38804	(662) 841-9500
MT	1776	McMillan, Jeremy Matthew	205 S. Atlantic Street	Dillon	59725	(406) 360-3636
MT	6304	Hightower, Rhett D. H.	501 1st Street	Havre	59501	(406) 262-9300
MT	7001	Erwin, Allan F.	203 N. 7th Avenue	Bozeman	59715	(406) 586-5431
MT	7002	Erwin, Allan F.	111 South Avenue West	Missoula	59801	(406) 721-7610
MT	7003	Hightower, Rhett D. H.	444 Broadwater Avenue	Billings	59101	(406) 256-1312
MT	7004	Fuller, James E.	700 N. Last Chance Gulch	Helena	59601	(406) 443-2454
MT	7005	Hightower, Rhett D. H.	2804 Grand Avenue	Billings	59102	(406) 652-5900
MT	7006	Hightower, Rhett D. H.	851 Shiloh Crossing Boulevard, Suites 1 & 2	Billings	59102	(406) 969-2871
MT	7007	Hightower, Rhett D. H.	904 Main Street, Suite 1	Billings	59105	(406) 245-6633
MT	7008	Hightower, Rhett D. H.	4109 2nd Avenue N	Great Falls	59405	(406) 771-0040

Exhibit B Traditional
as of December 31, 2023

MT	7009	Erwin, Allan F.	2101 Harrison Avenue	Butte	59701	(406) 782-3000
MT	7010	Hightower, Rhett D. H.	211 NW Bypass	Great Falls	59404	(406) 771-8877
MT	7011	Hightower, Rhett D. H.	150 Hutton Ranch Road, Suite 103	Kalispell	59901	(406) 756-0330
MT	7012	Hightower, Rhett D. H.	720 1st Avenue, Suite 1	Laurel	59044	(406) 530-1555
MT	7014	Erwin, Allan F.	410 North Central Avenue	Sidney	59270	(406) 630-7788
MT	7015	Hightower, Rhett D. H.	2750 Old Hardin Road, Suite K	Billings	59101	(406) 294-2828
MT	7016	Erwin, Allan F.	4921 North Reserve Street	Missoula	59808	(406) 926-6411
MT	7017	Erwin, Allan F.	19599 Frontage Road, Unit G & H	Belgrade	59714	(406) 813-8828
MT	7025	Hightower, Rhett D. H.	734 9th Street West, Suite 6	Columbia Falls	59912	(406) 892-3034
MT	7026	Erwin, Allan F.	2855 N. 19th Avenue, Suite H	Bozeman	59718	(406) 404-7755
MT	7029	Erwin, Allan F.	2410 South Park Street, Suite 102	Livingston	59047	(406) 823-3030
MT	7065	Erwin, Allan F.	1111 S. Haynes Avenue, Suite 2	Miles City	59301	(406) 852-5544
MT	7066	McMillan, Jeremy Matthew	318 Main Street	Polson	59860	(406) 872-4400
MT	7071	Hightower, Rhett D. H.	201 18th Street East	Kalispell	59901	(406) 607-6700
MT	7138	Hightower, Rhett D. H.	4470 King Avenue East, Suite 1	Billings	59101	(406) 894-4040
MT	9370	McMillan, Jeremy Matthew	901 S. 1st Street	Hamilton	59840	(406) 361-3030
NC	1706	Hess, David F.	132 East Main Street	Ahoskie	27910	(252) 862-4000
NC	4449	Soignet, Michael Woodrow	2531 E. Lyon Station Road, Suite G	Creedmoor	27522	(919) 528-2828
NC	4451	Hess, David F.	306 Granville Corners	Oxford	27565	(919) 603-0300
NC	4452	Patterson, G. Mack	553 S. Main Street	Mt. Holly	28120	(704) 822-2440
NC	4453	Ebert, Gale W.	4412 Falls of Neuse Road, Suite B109	Raleigh	27609	(919) 872-4000
NC	4454	Heaney, Sean T.	4890 Country Club Road	Winston-Salem	27104	(336) 768-4620
NC	4455	Qasim, S. Osman	3441 N. Main Street	Hope Mills	28348	(910) 424-4474
NC	4456	Ridge, Jenna Nichole	1205 E. Broad Avenue	Rockingham	28379	(910) 997-4424
NC	4457	Sobran, Michael Joseph	1400 S Croatan Highway Bypass 158 Milepost	Kill Devil Hills	27948	(252) 441-1525
NC	4458	Patterson, G. Mack	9107 - A South Tryon Street	Charlotte	28273	(704) 588-4182
NC	4459	Mehaffey, Paul G.	2448 Lewisville-Clemmons Road	Clemmons	27012	(336) 766-0566
NC	4460	Barber, John C.	400 North Lake Park Boulevard	Carolina Beach	28428	(910) 458-3334
NC	4461	Mitchell, Austin	1201 Cole Mill Road	Durham	27705	(919) 383-8399
NC	4462	Suniga-Koora, Jennifer P.	4201 N. Lee Street	Ayden	28513	(252) 746-4042
NC	4463	Qasim, S. Osman	1415 US Highway 52	Albemarle	28001	(704) 982-6777
NC	4464	Patterson, G. Mack	4112 Pleasant Valley Road, Suite 120	Raleigh	27612	(919) 783-5500
NC	4465	Hess, David F.	107 Jordan Plaza	Elizabeth City	27909	(252) 338-5811
NC	4468	Patterson, G. Mack	3233 The Plaza	Charlotte	28205	(704) 375-8794
NC	4469	Qasim, S. Osman	2305 W. Dickinson Avenue, Unit 110	Greenville	27834	(252) 756-9998
NC	4470	Patterson, G. Mack	3140 Dailas High Shoals Highway	Dallas	28034	(704) 922-7665
NC	4471	Davis, Bradley C.	614-R Main Street	King	27021	(336) 983-0303

Exhibit B Traditional
as of December 31, 2023

NC	4472	Heaney, Sean T.	5389 Gumtree Road	Winston-Salem	27107	(336) 769-4800
NC	4473	Davis, Bradley C.	1677 Westchester Drive	Highpoint	27262	(336) 887-2200
NC	4474	Patterson, G. Mack	2652 Highway 127 South	Hickory	28602	(828) 294-1050
NC	4476	Graham, Nicolas Shane	10555 NC Highway 8	Lexington	27292	(336) 357-2222
NC	4478	Qasim, S. Osman	3001 Holloway Street	Durham	27703	(919) 598-1111
NC	4479	Patel, Himanshu B.	100 Sixth Street	N. Wilkesboro	28659	(336) 838-7777
NC	4480	Qasim, S. Osman	197 W. Plaza Drive	Mooreville	28117	(704) 799-2222
NC	4481	Patterson, G. Mack	101 Stanford Road	Lincolnton	28092	(704) 732-4179
NC	4482	Barber, John C.	6620-A Gordon Road	Wilmington	28411	(910) 395-1166
NC	4483	Qasim, S. Osman	372 S. Broadway	Forest City	28043	(828) 245-3030
NC	4484	Barber, John C.	7224-H Wrightsville Avenue	Wilmington	28403	(910) 256-4964
NC	4485	Barber, John C.	5621-F Carolina Beach Road	Wilmington	28412	(910) 395-5556
NC	4486	Patterson, G. Mack	2603 Glenwood Avenue, Suite 131	Raleigh	27608	(919) 783-8803
NC	4487	Patterson, G. Mack	3716 West W. T. Harris Boulevard	Charlotte	28208	(704) 598-2230
NC	4488	Patterson, G. Mack	4510 Sunset Road, Unit A	Charlotte	28226	(704) 392-7850
NC	4490	Patterson, G. Mack	3335 Siskey Parkway, Suite 200	Mathews	28105	(704) 845-1800
NC	4491	Qasim, S. Osman	705 Grove Street, Suite 100	Fayetteville	28301	(910) 433-3030
NC	4492	Patel, Himanshu B.	2937 NC Highway 16	Millers Creek	28651	(336) 818-4355
NC	4493	Ferone, Steven	143-B South White Street	Wake Forest	27587	(919) 554-1155
NC	4495	Soignet, Michael Woodrow	10411 Moncreiffe Road, Suite 101	Raleigh	27617	(919) 957-2929
NC	5500	Patterson, G. Mack	3677 New Bern Avenue	Raleigh	27610	(919) 231-6007
NC	5501	Patterson, G. Mack	2658 S. Saunders	Raleigh	27603	(919) 821-2330
NC	5502	Patterson, G. Mack	412 E. Main Street	Carrboro	27510	(919) 929-0246
NC	5503	Mitchell, Austin	1209 W. Main Street	Durham	27701	(919) 682-3030
NC	5504	Ebert, Gale W.	7315 Six Forks Road	Raleigh	27615	(919) 847-8855
NC	5505	Farrior, Mark S.	1367 S.E. Maynard Road	Cary	27511	(919) 469-1115
NC	5506	Patterson, G. Mack	3948 Western Boulevard	Raleigh	27606	(919) 899-3599
NC	5507	Patterson, G. Mack	235 S. Elliot Road	Chapel Hill	27514	(919) 967-0006
NC	5508	Kiger, Justin Brady	3205 University Drive	Durham	27707	(919) 493-8484
NC	5509	Stokes, Clyde Page	1837 S Church Street	Burlington	27215	(336) 229-7777
NC	5510	Kiger, Justin Brady	4237 Louisburg. Road #103	Raleigh	27604	(919) 872-7222
NC	5511	Stokes, Clyde Page	2447 N. Church Street E. Village Plaza	Burlington	27217	(336) 229-1199
NC	5512	Mitchell, Austin	4502 Roxboro Road	Durham	27704	(919) 477-1966
NC	5513	Rhodes, Gerald B.	709 S Clinton Avenue	Dunn	28334	(910) 892-8002
NC	5514	Crum, Bart H.	200 East 10th Street	Roanoke Rapids	27870	(252) 535-1444
NC	5515	Qasim, S. Osman	110 Spring Avenue	Spring Lake	28390	(910) 436-4151
NC	5516	Qasim, S. Osman	596 N. Reilly Road #3	Fayetteville	28303	(910) 868-9595

Exhibit B Traditional
as of December 31, 2023

NC	5517	Qasim, S. Osman	2922 Bragg Boulevard	Fayetteville	28303	(910) 483-8833
NC	5518	Qasim, S. Osman	5133 Raeferd Road #10	Fayetteville	28304	(910) 424-4884
NC	5519	Qasim, S. Osman	5387 Ramsey Street	Fayetteville	28311	(910) 822-5960
NC	5521	Gage, Stanley J.	345 Western Boulevard, Suite C	Jacksonville	28546	(910) 577-1500
NC	5522	Rhodes, Gerald B.	1174 N Main Street	Lillington	27546	(910) 984-1133
NC	5523	Young, Kevin Ashley	4917 Arendel Street	Morehead City	28557	(252) 247-0300
NC	5524	Tingen, Michael L.	1570 Freeway Drive	Reidsville	27320	(336) 342-3555
NC	5525	Gage, Stanley J.	321 W Main Street	Havelock	28532	(252) 447-3000
NC	5526	Qasim, S. Osman	122 Avalon Drive	Salisbury	28144	(704) 603-3225
NC	5527	Ridge, John E., Jr.	588- A Bailey Road	Lumberton	28358	(910) 739-4121
NC	5528	Toms, Daniel J.	640 S. Van Buren Street	Eden	27288	(336) 623-4040
NC	5530	Qasim, S. Osman	1201 Charles Boulevard	Greenville	27834	(252) 758-6660
NC	5531	Qasim, S. Osman	1613 Raleigh Road	Wilson	27896	(252) 237-4444
NC	5532	Blackman, Tonya Letts	900 Sunburst Drive	Goldsboro	27534	(919) 778-7260
NC	5533	Crum, Bart H.	161 Falls of the Tar Court	Rocky Mount	27804	(252) 977-7777
NC	5534	Qasim, S. Osman	3192-A E. 10th Street	Greenville	27858	(252) 752-6996
NC	5535	Qasim, S. Osman	1201 W Vernon Avenue, Suite E	Kinston	28501	(252) 523-4422
NC	5536	Patterson, G. Mack	5922 Weddington-Monroe Road A14	Wesley Chapel	28104	(980) 289-0500
NC	5537	Kiger, Justin Brady	1601 Highway 54	Durham	27713	(919) 544-1751
NC	5538	Heaney, Sean T.	12201 North NC Highway 150, #7	Winston Salem	27127	(336) 775-1100
NC	5539	Heaney, Sean T.	450 Knollwood Street	Winston-Salem	27103	(336) 659-0065
NC	5540	Mehaffey, Paul G.	7821 North Point Boulevard	Winston-Salem	27106	(336) 759-2011
NC	5541	Qasim, S. Osman	820 S. Chapman Street	Greensboro	27403	(336) 272-6156
NC	5542	Qasim, S. Osman	4604 W. Market Street, Suite A	Greensboro	27407	(336) 854-1591
NC	5543	Patterson, G. Mack	2801 Freedom Drive	Charlotte	28208	(704) 573-4800
NC	5544	Qasim, S. Osman	1103 E. Bessemer Avenue	Greensboro	27405	(336) 272-9833
NC	5545	Patterson, G. Mack	360 Wilkesboro Boulevard SE	Lenoir	28645	(828) 758-7011
NC	5546	Davis, Bradley C.	2205 Kirkwood Street #104	High Point	27262	(336) 841-2115
NC	5547	Moss, Luke James	2310 S Main Street	High Point	27263	(336) 889-7424
NC	5548	Heaney, Sean T.	900 W. Cooksey Drive, Suite E&F	Thomasville	27360	(336) 472-6111
NC	5549	Patterson, G. Mack	702 Blowing Rock Road, Suite 3	Boone	28607	(828) 264-6507
NC	5550	Patterson, G. Mack	3205 N Sharon Amity Road	Charlotte	28205	(704) 531-7713
NC	5551	Patterson, G. Mack	9630-F University City Boulevard	Charlotte	28213	(704) 596-7071
NC	5552	Patterson, G. Mack	4755 South Boulevard	Charlotte	28217	(704) 527-7892
NC	5553	Davis, Bradley C.	256 Summit Square Boulevard	Winston-Salem	27105	(336) 701-0077
NC	5556	Qasim, S. Osman	601 S. Cannon Boulevard	Kannapolis	28083	(704) 933-4444
NC	5557	Patterson, G. Mack	1802 South New Hope Road	Gastonia	28054	(704) 867-5868

Exhibit B Traditional
as of December 31, 2023

NC	5558	Qasim, S. Osman	1837 E. Broad Street #A	Statesville	28625	(704) 872-3030
NC	5559	Qasim, S. Osman	210 W. Dixon Road	Shelby	28152	(704) 484-1717
NC	5560	Patterson, G. Mack	1231 Burkemont Avenue, Suite H	Morganton	28655	(828) 608-0999
NC	5561	Kiger, Justin Brady	5950 Poyner Village Parkway, Unit 505	Raleigh	27616	(984) 242-4471
NC	5563	Rhodes, Gerald B.	145 W. Plaza Drive, Unit F	Seven Lakes	27376	(910) 466-9067
NC	5564	Patterson, G. Mack	814 N. Charlotte Avenue	Monroe	28110	(704) 289-3500
NC	5565	Rhodes, Gerald B.	11109 US Highway 15 501, Suite 1	Aberdeen	28315	(910) 692-6662
NC	5566	Qasim, S. Osman	825 Spartanburg Highway	Hendersonville	28792	(828) 696-4113
NC	5567	Patterson, G. Mack	1563 E. Union Street	Morganton	28655	(828) 437-9777
NC	5568	Patterson, G. Mack	1131 2nd Street NE	Hickory	28601	(828) 324-5111
NC	5569	Patterson, G. Mack	3204 Springs Road NE	Hickory	28601	(828) 256-9811
NC	5570	Rhodes, Gerald B.	1602 S. Horner Boulevard	Sanford	27330	(919) 774-4448
NC	5571	Rhodes, Gerald B.	825 N. Brightleaf Boulevard	Smithfield	27577	(919) 934-1221
NC	5572	Rhodes, Gerald B.	10441 U.S. 70 Highway West	Clayton	27520	(919) 553-3066
NC	5573	Hess, David F.	1017 Durham Road	Roxboro	27573	(336) 597-8585
NC	5574	Davis, Bradley C.	1015 Rockford Street, Suite 103	Mount Airy	27030	(336) 786-1414
NC	5575	Thomas, Paul L.	114-A W. Main Street	Jamestown	27282	(336) 454-6116
NC	5576	Patterson, G. Mack	14013 North Creek Village Drive, Suite 400	Huntersville	28078	(980) 341-8005
NC	5577	Patterson, G. Mack	1600 Cross Link Road, Unit 101	Raleigh	27610	(919) 828-8500
NC	5578	Qasim, S. Osman	1304 John Small Avenue	Washington	27889	(252) 946-7778
NC	5579	Qasim, S. Osman	600 Church Street	Concord	28025	(704) 795-5555
NC	5580	Ridge, John E. Jr.	1712 US Highway 401 S	Laurinburg	28352	(910) 276-4440
NC	5581	Qasim, S. Osman	1601 W. Innes Street	Salisbury	28144	(704) 636-1111
NC	5582	Qasim, S. Osman	4411 Gate City Boulevard	Greensboro	27407	(336) 854-0044
NC	5583	Qasim, S. Osman	124 West Ward Street	Asheboro	27203	(336) 629-2468
NC	5585	Patterson, G. Mack	4350 Colwick Road	Charlotte	28211	(704) 364-5192
NC	5586	Ridge, John E. Jr.	2739 W. 5th Street	Lumberton	28358	(910) 802-5050
NC	5587	Tingen, Michael L.	1120 S. Main Street, Suite M	Kernersville	27284	(336) 996-7807
NC	5588	Rhodes, Gerald B.	2258 Jefferson Davis Highway	Sanford	27330	(919) 774-8001
NC	5589	Barber, John C.	4714 College Acres Drive	Wilmington	28403	(910) 799-8820
NC	5590	Patterson, G. Mack	7211 E. Independence Boulevard, Suite J	Charlotte	28227	(704) 536-6444
NC	5591	Patterson, G. Mack	735 Highway 70 West	Garner	27529	(919) 779-6600
NC	5592	Qasim, S. Osman	1051 Alamance Church Road	Greensboro	27406	(336) 370-1471
NC	5593	Patterson, G. Mack	1428 E. Fourth Street	Charlotte	28204	(704) 331-9847
NC	5594	Crum, Bart H.	1004 Western Boulevard	Tarboro	27886	(252) 823-5555
NC	5595	Soignet, Michael Woodrow	3460 US Highway 1	Franklinton	27525	(919) 494-1499
NC	5596	Qasim, S. Osman	13045 NC Highway 24-27, Suite B	Eagle Springs	27242	(910) 948-2111

Exhibit B Traditional
as of December 31, 2023

NC	5597	Tingen, Michael L.		5136 Randleman Road	Greensboro	27406	(336) 674-0027
NC	5617	Gage, Stanley J.		2543 Onslow Drive, Unit 1 and 2	Jacksonville	28540	(910) 526-0030
NC	5997	Gage, Stanley J.		2400 Neuse Boulevard	New Bern	28562	(252) 631-9999
NC	7420	Gage, Stanley J.		991 NC Highway 210	Sneads Ferry	28460	(910) 327-3272
NC	7421	Patterson, G. Mack		2020-1 Connelly Springs Road	Lenoir	28645	(828) 728-1828
NC	7422	Rhodes, Gerald B.		104 Five Points Road	Goldsboro	27530	(919) 734-4004
NC	7423	Mehaffey, Paul G.		4655 Yadkinville Road	Pfafftown	27040	(336) 922-7080
NC	7424	Patterson, G. Mack		1310 Wesley Chapel Road, Suite H	Indian Trail	28079	(704) 684-0200
NC	7426	Patterson, G. Mack		14154 Steele Creek Road, Suite 150	Charlotte	28273	(704) 588-2200
NC	7428	Barber, John C.		1096-5 Sabbath Home Road	Supply	28462	(910) 846-3344
NC	7430	Barber, John C.		409 Highway 117 North	Burgaw	28425	(910) 259-5252
NC	7431	Patterson, G. Mack		13220 Strickland Road, Suite 190	Raleigh	27613	(919) 676-6602
NC	7432	Mehaffey, Paul G.		528-B Hawthorne Road	Yadkinville	27055	(336) 679-4444
NC	7433	Young, Kevin Ashley		98 Crescent Drive	Beaufort	28516	(252) 728-5002
NC	7434	Qasim, S. Osman		1483 Patton Avenue	Asheville	28806	(828) 232-1818
NC	7436	Patterson, G. Mack		12905 Rosedale Hill Avenue	Huntersville	28078	(704) 992-0505
NC	7438	Rhodes, Gerald B.		107 North Honeycutt Street	Benson	27504	(919) 207-5678
NC	7439	Qasim, S. Osman		1336 E. Main Street, Suite C	Sylva	28779	(828) 586-9400
NC	7441	Rhodes, Gerald B.		306 Fish Drive	Angier	27501	(919) 331-2444
NC	7442	Tingen, Michael L.		2040 I Rankin Mill Road	Greensboro	27405	(336) 375-0992
NC	7447	Tingen, Michael L.		8532 Hillsville Road	Trinity	27370	(336) 861-0990
NC	7472	Graham, Nicolas Shane		114 E. Center Street	Lexington	27292	(336) 238-7272
NC	7473	Qasim, S. Osman		417 E. Main Street	Franklin	28734	(828) 369-1919
NC	7477	Stokes, Clyde Page		6307 Burlington Road, Suite M	Stoney Creek	27377	(336) 449-5600
NC	7480	Farrior, Mark S.		9825-E Chapel Hill Road	Morrisville	27513	(919) 319-7000
NC	7483	Ridge, John E. Jr.		1629 South Madison Street	Whiteville	28472	(910) 640-2211
NC	7484	Crum, Bart H.		242 N. Eastpointe Avenue	Nashville	27856	(252) 459-3388
NC	7485	Mehaffey, Paul G.		430 Valley Road	Mocksville	27028	(336) 751-3232
NC	7487	Kennedy, Philip A.		1121-104 Falls River Avenue	Raleigh	27614	(919) 870-1155
NC	7488	Qasim, S. Osman		16 Cherokee Crossing, Suite 10	Cherokee	28719	(828) 497-5500
NC	7489	Qasim, S. Osman		1003 High Point Street #A9	Randleman	27317	(336) 495-3030
NC	7490	City, Ryke G.		5121 NC Highway 42 West, Suite 130B	Garner	27529	(919) 662-0303
NC	8800	Heaney, Sean T.		1585 Liberty Street, Unit 1	Greensboro	27360	(336) 656-8900
NC	8802	Qasim, S. Osman		5100 NC Highway 87 South, Suite 102	Fayetteville	28306	(910) 484-3226
NC	8803	Barber, John C.		6001-3 Castle Hayne Road	Castle Hayne	28429	(910) 602-7575
NC	8804	Patterson, G. Mack		1830 Galleria Boulevard	Charlotte	28270	(980) 890-9100
NC	8806	Qasim, S. Osman		608 Turnersburg Highway	Statesville	28625	(704) 380-4898

Exhibit B Traditional
as of December 31, 2023

NC	8807	Qasim, S. Osman	78 New Clyde Highway	Canton	28716	(828) 648-7499
NC	8808	Gage, Stanley J.	100 Highway 172	Hubert	28539	(910) 219-4115
NC	8809	Gage, Stanley J.	949 US Highway 70 E	New Bern	28560	(252) 514-2072
NC	8810	Ridge, John E. Jr.	311 Harris Avenue	Raeford	28376	(910) 848-2007
NC	8811	Ridge, John E. Jr.	7082 Fayetteville Road	Raeford	28376	(910) 875-8001
NC	8812	Rhodes, Gerald B.	109 Martin Road	Goldsboro	27530	(919) 705-2363
NC	8813	Hess, David F.	558 Caratoke Highway	Moyock	27958	(252) 435-2500
NC	8814	Barber, John C.	9413 Ploof Road, Unit A	Leland	28451	(910) 371-3770
NC	8816	Hess, David F.	987-I East Street	Pittsboro	27312	(919) 542-1295
NC	8817	Patterson, G. Mack	10210 Couloak Drive, Suite G	Charlotte	28216	(704) 393-8887
NC	8818	Rhodes, Gerald B.	17 Amarillo Lane	Sanford	27332	(919) 499-5557
NC	8819	Rhodes, Gerald B.	7451B NC Highway 22	Carthage	28327	(910) 949-3300
NC	8820	Rhodes, Gerald B.	6213-102 Rock Quarry Road	Raleigh	27610	(919) 779-4443
NC	8821	Patterson, G. Mack	9900 Poplar Tent Road, Suite #105	Concord	28027	(704) 788-3600
NC	8823	D'Andrea, Peter P.	2455 Tarawa Boulevard	Tarawa Terrace	28543	(910) 353-3111
NC	8824	Ferone, Steven	6110 Rogers Road	Rolesville	27571	(919) 453-2324
NC	8825	Patterson, G. Mack	16625 Lancaster Highway, Suite 103	Charlotte (Audrey Keil)	28277	(704) 542-6767
NC	8826	Hess, David F.	139 W. Main Street	Williamston	27982	(252) 792-4333
NC	8829	Rhodes, Gerald B.	78 N. McKinley Street	Coats	27521	(910) 292-0003
NC	8830	Qasim, S. Osman	337 Walnut Street	Waynesville	28786	(828) 454-9900
NC	8836	Crum, Bart H.	3335 N. Hathaway Boulevard	Sharpsburg	27878	(252) 407-7977
NC	8839	Hess, David F.	903 S. Beckford Drive	Henderson	27536	(252) 438-2727
NC	8840	Qasim, S. Osman	460 Weaverville Highway	Asheville	28804	(828) 645-1010
NC	8841	Rhodes, Gerald B.	375 Athletic Club Boulevard	Clayton	27527	(919) 585-7755
NC	8842	Ridge, John E. Jr.	350 S. 5th Street	St. Pauls	28384	(910) 885-9151
NC	8843	O'Leary, John P.	12330 NC Highway 210, Suite 104	Benson	27504	(919) 205-1471
NC	8844	Qasim, S. Osman	7602A Highway 73 E.	Mount Pleasant	28124	(704) 436-1117
NC	8845	Patterson, G. Mack	4463 School House Commons	Harrisburg	28075	(980) 505-7999
NC	8846	Patterson, G. Mack	508 10th Street NW, Unit N	Conover	28613	(828) 469-7474
NC	8847	Patterson, G. Mack	2515 Park Road	Charlotte	28203	(704) 665-5151
NC	8848	Qasim, S. Osman	803 Armistead Street	Pope Army Air Field	28308	(910) 500-8030
NC	8849	Farrior, Mark S.	708 Slash Pine Drive	Cary	27519	(919) 439-5859
NC	8850	Qasim, S. Osman	1863 Hendersonville Road, Unit 112	Asheville	28803	(828) 277-1010
NC	8851	Qasim, S. Osman	5445 Asheville Highway	Hendersonville	28791	(828) 687-1010
NC	8852	Heaney, Sean T.	630 W. Fourth Street	Winston-Salem	27101	(336) 724-1600
NC	8853	Qasim, S. Osman	6482 Brevard Road	Etowah	28729	(828) 891-6677
NC	8854	Qasim, S. Osman	4000 Ward Boulevard Building L	Wilson	27893	(252) 674-1555

Exhibit B Traditional
as of December 31, 2023

NC	8855	Patterson, G. Mack	135 E Davie Street	Raleigh	27601	(919) 239-4219
NC	8856	Patterson, G. Mack	110-7 West King Street	Kings Mountain	28086	(704) 734-0999
NC	8857	Thomas, Paul L.	2762 HWY 68, Unit A	High Point	27265	(336) 841-4000
NC	8858	Patterson, G. Mack	2900 Derita Road	Concord	28207	(704) 548-8688
NC	8859	Rhodes, Gerald B.	215 Ivey Lane	Taylortown	28374	(910) 420-2728
NC	8861	Barber, John C.	318 Village Road	Leland	28451	(910) 490-9000
NC	8863	Patterson, G. Mack	709 East Church Street	Cherryville	28021	(704) 435-9900
NC	8864	Patterson, G. Mack	206 South Highway 27	Stanley	28164	(880) 655-0500
NC	8878	Patterson, G. Mack	974 South Point Road, Suite A	Belmont	28012	(704) 317-7100
NC	8901	Gage, Stanley J.	2222 Gum Branch Road, Suite B	Jacksonville	28540	(910) 455-3252
NC	8902	Stokes, Clyde Page	1348 Java Lane, Suite 103	Burlington	27215	(336) 516-9999
NC	8903	Farior, Mark S.	1183 W. Chatham Street	Cary	27511	(919) 467-4222
NC	8904	O'Brien, Michael D.	4711 Hope Valley Road #1-B	Durham	27707	(919) 493-4077
NC	8905	Traub, Tamra Nicole	304 Northeast Boulevard	Clinton	28328	(910) 592-4099
NC	8906	Qasim, S. Osman	2130-B New Garden Road	Greensboro	27410	(336) 545-0000
NC	8907	Stokes, Clyde Page	417 W. Haggard Avenue	Elon College	27244	(336) 584-3336
NC	8908	Patterson, G. Mack	833 Perry Road	Apex	27502	(919) 387-0030
NC	8909	Patterson, G. Mack	20601 Torrence Chapel Road, Suite 109	Cornelius	28031	(704) 897-8888
NC	8910	Qasim, S. Osman	114 S. Washington Street	Rutherfordton	28139	(828) 287-3030
NC	8911	Qasim, S. Osman	1357 Shearer Road	Mooreville	28115	(880) 435-4545
NC	8912	Qasim, S. Osman	3806-C N. Church Street	Greensboro	27405	(336) 621-3399
NC	8913	Qasim, S. Osman	2202-B Fleming Road	Greensboro	27410	(336) 665-1744
NC	8914	Stokes, Clyde Page	921 S. Main Street	Graham	27253	(336) 570-2262
NC	8915	Patterson, G. Mack	8510 Park Road	Charlotte	28210	(704) 554-5629
NC	8916	Patterson, G. Mack	6420 B-1 Rea Road	Charlotte	28277	(704) 543-7160
NC	8917	Patterson, G. Mack	3901-G Providence Road S.	Waxhaw	28173	(704) 843-3566
NC	8918	Patterson, G. Mack	9020-A2 Albemarle Road	Charlotte	28227	(704) 531-0300
NC	8919	Ridge, John E. Jr.	5051 Main Street #2	Shallotte	28470	(910) 755-3386
NC	8920	Patterson, G. Mack	110 Banks Drive	Chapel Hill	27514	(919) 932-9500
NC	8921	Gage, Stanley J.	3551 Martin Luther King Jr. Boulevard	New Bern	28562	(252) 649-0000
NC	8924	Gage, Stanley J.	1135 Old Maplehurst Road	Jacksonville	28540	(910) 346-7771
NC	8925	Patterson, G. Mack	1284 W. Williams Street, Suite #201	Apex	27502	(919) 303-0800
NC	8926	D'Andrea, Peter P.	1515 Holcomb Boulevard	Camp Lejeune	28547	(910) 968-3111
NC	8927	Qasim, S. Osman	2951 Town Center Drive, Suite 101	Hope Mills	28348	(910) 421-2220
NC	8928	Qasim, S. Osman	1086 River Highway, Suite E	Mooreville	28117	(704) 746-9100
NC	8929	Gage, Stanley J.	3311 Richlands Highway	Jacksonville	28540	(910) 968-3030
NC	8930	Patterson, G. Mack	112 John Earl Street	Hillsborough	27278	(919) 732-3001

Exhibit B Traditional
as of December 31, 2023

NC	8931	Brannan, Craig W.	15489 US Highway 17 North	Hampstead	28443	(910) 270-2222
NC	8932	Farrior, Mark S.	115 Parkside Valley Drive, Suite 20	Morrisville	27560	(919) 897-8800
NC	8934	Patterson, G. Mack	3876 Kings Mountain Highway	Gastonia	28052	(704) 864-4475
NC	8935	Patterson, G. Mack	2819 Wendell Boulevard	Wendell	27591	(919) 365-9192
NC	8936	Stokes, Clyde Page	1246 S. 5Th Street	Mebane	27302	(919) 563-5999
NC	8937	Hess, David F.	11312 Highway 15-501 N., Suite 100	Chapel Hill	27517	(919) 968-3334
NC	8938	Patterson, G. Mack	2001 Widewaters Parkway, Suite R	Knightdale	27545	(919) 266-6667
NC	8939	Qasim, S. Osman	4612 Woody Mill Road, Suite 101	Greensboro	27406	(336) 698-4500
NC	8940	Farrior, Mark S.	1368 N. Main Street, Sunset Plaza	Fuquay-Varina	27526	(919) 557-5551
NC	8941	Barber, John C.	204-B North New River Drive	Surf City	28445	(910) 328-8888
NC	8942	Heaney, Sean T.	789 E. Main Street	Jefferson	28640	(336) 649-8474
NC	8943	Barber, John C.	3604 South College Road, Unit A	Wilmington	28412	(910) 452-5363
NC	8944	Barber, John C.	7208 Market Street	Wilmington	28411	(910) 686-9889
NC	8945	Barber, John C.	5003 E Oak Island Drive	Oak Island	28465	(910) 278-9111
NC	8946	Patterson, G. Mack	530 Dudley Shoals Road	Granite Falls	28630	(828) 313-0555
NC	8947	Crum, Bart H.	8551 NC Highway 56 West	Louisburg	27549	(919) 497-0400
NC	8948	Davis, Bradley C.	802 South Main Street #101	Walnut Cove	27052	(336) 591-3120
NC	8949	Patel, Himanshu B.	821 W. Main Avenue	Taylorsville	28681	(828) 635-6868
NC	8950	Barber, John C.	6278 Beach Drive SW, Suite 112	Ocean Isle	28469	(910) 575-3800
NC	8951	Qasim, S. Osman	1418 East 11 Street	Siler City	27344	(919) 742-1100
NC	8952	Qasim, S. Osman	8130 Cliffdale Road	Fayetteville	28314	(910) 868-8111
NC	8953	Gage, Stanley J.	7075 US Highway 70 E	Newport	28570	(252) 223-2020
NC	8954	Gage, Stanley J.	604 Cedar Point Boulevard, Unit F	Cedar Point	28584	(252) 393-6800
NC	8955	Barber, John C.	1671 N. Howe Street, Suite 1B	Southport	28461	(910) 457-0083
NC	8956	Mehaffey, Paul G.	835 N. Bridge Street	Elkin	28621	(336) 526-5525
NC	8957	Tingen, Michael L.	131 Commerce Lane	Mayodan	27027	(336) 548-2080
NC	8958	Patterson, G. Mack	7981 Fayetteville Road, Suite 7	Raleigh	27603	(919) 661-2612
NC	8959	Gage, Stanley J.	8106 Richlands Highway	Richlands	28574	(910) 324-2722
NC	8960	Davis, Bradley C.	4760 Walkertown Plaza, Boulevard	Walkertown	27051	(336) 595-1155
NC	8961	Rhodes, Gerald B.	2800 Nc Highway 24-87	Cameron	28326	(910) 436-3031
NC	8962	Qasim, S. Osman	6926 Jordan Road	Ramseur	27316	(336) 824-2121
NC	8963	Qasim, S. Osman	623 Highway 29 North	China Grove	28023	(704) 857-8888
NC	8965	Barber, John C.	3228-B N. College Road	Wilmington	28405	(910) 858-8000
NC	8966	Barber, John C.	5680 South N.C. Highway 41, Space No. 1	Wallace	28466	(910) 285-9996
NC	8968	Patterson, G. Mack	7900-K Stevens Mill Road	Mathews	28105	(704) 882-5100
NC	8970	Qasim, S. Osman	327 W. Main Street	Biscoe	27209	(910) 428-1211
NC	8972	Patel, Himanshu B.	Rockefeller Centre #12310 Highway 16 North	Denver	28037	(704) 489-8686

Exhibit B Traditional
as of December 31, 2023

NC	8973	Rhodes, Gerald B.			1124 N. Breazeale Avenue	Mount Olive	28365	(919) 635-2181
NC	8975	Patterson, G. Mack			2935 US Highway 70	Connelly Springs	28612	(828) 397-6790
NC	8977	Qasim, S. Osman			609 W. Main Street	Rockwell	28138	(704) 209-3333
NC	8978	Patterson, G. Mack			2110 Crossway Lane	Holly Springs	27540	(919) 567-2330
NC	8979	Patterson, G. Mack			909 N Main Street	Marion	28752	(828) 583-0300
NC	8980	Farrior, Mark S.			2881 Jones Franklin Road	Raleigh	27606	(919) 235-0808
NC	8982	Mehaffey, Paul G.			250 NC Highway 801 N.	Advance	27006	(336) 998-2000
NC	8983	Barber, John C.			1600 Market Street	Wilmington	28401	(910) 251-1111
NC	8984	Tingen, Michael L.			8001-E Marketplace Drive	Oak Ridge	27310	(336) 644-0665
NC	8986	Patterson, G. Mack			2392 NC Highway 10 West	Newton	28658	(828) 464-4445
NC	8987	Ridge, John E. Jr.			412 B W. 3rd Street	Pembroke	28372	(910) 521-2223
NC	8988	Qasim, S. Osman			1269 Tunnel Road	Asheville	28715	(828) 298-2700
NC	8989	Barber, John C.			2416 Carolina Beach Road, Unit 5	Wilmington	28401	(910) 332-1234
NC	8991	Rhodes, Gerald B.			3254 Ray Road	Spring Lake	28390	(910) 496-0772
NC	8992	Qasim, S. Osman			1050 W. Main Street A	Locust	28097	(704) 888-1313
NC	8993	Qasim, S. Osman			265-D North Main Street	Troutman	28166	(704) 528-1500
NC	8994	Graham, Nicolas Shane			6479 Old US Highway 52	Lexington	27295	(336) 731-8888
NC	8995	Barber, John C.			1008 West Broad Street	Elizabethtown	28337	(910) 872-0907
NC	8996	Tingen, Michael L.			998 NC 150 West	Summerfield	27358	(336) 643-6002
NC	9020	Ferone, Steven			2114 S. Main Street	Wake Forest	27587	(919) 562-0330
NC	9861	Qasim, S. Osman			1017 Canopy Lane, South Post Food Ct.	Fort Bragg	28310	(910) 436-2244
ND	1851	Graves, Susan L.			2705 S. Washington Street	Grand Forks	58201	(701) 746-6437
ND	1852	Graves, Susan L.			400 A Avenue	Emerado	58228	(701) 594-4467
ND	1853	Graves, Susan L.			102 4th Street S.	Wahpeton	58075	(701) 642-2212
ND	1854	Erwin, Allan F.			521 Main Street	Williston	58801	(701) 572-8888
ND	1859	Graves, Susan L.			1531C University Drive	Fargo	58103	(701) 293-9390
ND	1860	Graves, Susan L.			1109 19th Avenue N.	Fargo	58102	(701) 232-1255
ND	1861	Graves, Susan L.			1700 32nd Avenue South	Fargo	58103	(701) 232-5333
ND	1862	Graves, Susan L.			1380 9th Street E.	West Fargo	58078	(701) 282-8055
ND	1865	Jensen, Frank E.			706 1st Avenue S.	Jamestown	58401	(701) 252-8888
ND	1871	Knudson, Lucinda Anne			1100 E. Main Street	Mandan	58554	(701) 663-6988
ND	1872	Knudson, Lucinda Anne			119 E Century Avenue	Bismarck	58503	(701) 258-4030
ND	1873	Knudson, Lucinda Anne			1031 South Washington	Bismarck	58501	(701) 222-3100
ND	1875	Graves, Susan L.			3955 56th Street South, Suite A	Fargo	58104	(701) 929-6296
ND	1876	Erwin, Allan F.			237 14th Street W.	Dickinson	58601	(701) 483-7712
ND	1881	Graves, Susan L.			801 42nd Street South, Suite A	Grand Forks	58201	(701) 314-2881
ND	1882	Erwin, Allan F.			1524 S. Broadway	Minot	58701	(701) 838-8383

Exhibit B Traditional
as of December 31, 2023

ND	1883	Erwin, Allan F.	401 West Villard, Suite #101 & #102	Dickinson	58601	(701) 225-7100
NE	6101	Peterson, Wayne A.	1230 P Street	Lincoln	68508	(402) 817-3988
NE	6102	Peterson, Wayne A.	2401 N. 48th Street	Lincoln	68504	(402) 434-2377
NE	6103	Peterson, Wayne A.	6125 Apples Way, Suite 201	Lincoln	68516	(631) 289-7700
NE	6104	Peterson, Lance Russell	1055 Saunders	Lincoln	68521	(402) 434-2380
NE	6105	Peterson, Wayne A.	2815 South 18th Street	Lincoln	68502	(402) 434-2388
NE	6110	Graves, Susan L.	2015 Pratt Avenue, Suite 113	Bellevue	68123	(402) 292-4700
NE	6111	Graves, Susan L.	7120 Military Avenue	Omaha	68104	(402) 898-9393
NE	6112	Graves, Susan L.	721 South 72nd Street, Suite #105	Omaha	68114	(402) 614-7990
NE	6119	Graves, Susan L.	7419 North 30th Street	Omaha	68112	(631) 213-2316
NE	6120	Graves, Susan L.	629 Saddlecreek Road	Omaha	68132	(631) 466-3234
NE	6121	Graves, Susan L.	2728 Street Mary's Avenue	Omaha	68105	(402) 345-3030
NE	6122	Graves, Susan L.	4122 S. 144th Street	Omaha	68137	(402) 895-8833
NE	6123	Graves, Susan L.	920 N. 204th Avenue, Suite 110	Elkhorn	68022	(531) 466-2630
NE	6124	Graves, Susan L.	7051 S. 181st Street, Suite 101	Omaha	68136	(402) 502-4302
NE	6125	Graves, Susan L.	3818 N. 156th Street	Omaha	68116	(402) 496-3330
NE	6126	Graves, Susan L.	2155 E. 23rd Street	Fremont	68025	(402) 721-1444
NE	6127	Graves, Susan L.	3439 L Street	Omaha	68107	(402) 933-2100
NE	6128	Peterson, Lance Russell	2409 23rd Street	Columbus	68601	(402) 562-5656
NE	6130	Lawrence, Noelle Dawn	904 Riverside Boulevard, Unit A	Norfolk	68701	(402) 371-0107
NE	6131	Ramold, Robert C.	618 South Burlington Avenue	Hastings	68901	(402) 902-4646
NE	6132	Ramold, Robert C.	1815-1/2 W. A Street	North Platte	69101	(308) 534-0400
NE	6135	Graves, Susan L.	4845 N. 90th Street	Omaha	68134	(402) 401-6609
NE	6140	Hackett, Michael D.	1519 West 6th Street	Chadron	69937	(308) 747-2203
NE	6141	Peterson, Wayne A.	2801 Pine Lake Road, Suite R	Lincoln	68516	(402) 413-7772
NE	6150	Ramold, Robert C.	3702 2nd Avenue	Kearney	68847	(308) 234-6544
NE	6151	Tyson, Michael Francis	1820 N. 6th Street, Unit #1	Beatrice	68310	(402) 520-8300
NE	6155	Hackett, Michael D.	1015 W. 27th Street	Scottsbluff	69361	(308) 635-0330
NE	6160	Graves, Susan L.	1449 Papillion Drive	Papillion	68046	(402) 933-0037
NE	6161	Ramold, Robert C.	624 N. Webb	Grand Island	68801	(308) 389-3030
NE	6198	Hackett, Michael D.	2915 N. 10th Street	Gering	69341	(308) 633-0003
NE	6389	Peterson, Lance Russell	132 S. 5th Street, Suite B	Seward	68434	(402) 803-1955
NE	6612	Graves, Susan L.	9631 Giles Road	La Vista	68128	(402) 884-9120
NE	6698	Graves, Susan L.	323 N. 14th Street	Omaha	68154	(402) 905-0265
NH	3144	Bell, Keith	1 Silver Fox Lane	Raymond	03077	(877) 883-9643
NH	3190	Rivard, Robert P.	184 Route 101, Unit #2	Bedford	03110	(603) 965-2000
NH	3193	Hunt, Travis William	38 New Hampshire Route 25	Meredith	03253	(603) 707-4222

Exhibit B Traditional
as of December 31, 2023

NH	3200	Rivard, Robert P.	60 Beech Street	Manchester	03103	(603) 647-4300
NH	3201	Jenks / Benvenuti, David / Dominic	599 Lafayette Road	Portsmouth	03801	(603) 431-7881
NH	3202	Yeames, Richard C.	202 N. Main Street	Concord	03301	(603) 228-4222
NH	3203	Bell, Keith	216 Washington Street	Claremont	03743	(603) 542-3333
NH	3204	Rivard, Robert P.	212 Lowell Street	Manchester	03103	(603) 668-4701
NH	3205	Zonfrilli, Joseph V.	60 Island Street	Keene	03431	(603) 357-5534
NH	3206	Rivard, Robert P.	150 Armory Street	W. Manchester	03102	(603) 668-2252
NH	3207	Jenks / Benvenuti, David / Dominic	99 Northeastern Boulevard	Nashua	03062	(603) 889-8885
NH	3208	Rivard, Robert P.	254 North Broadway, Suite 105	Salem	03079	(603) 893-7100
NH	3209	Jenks / Benvenuti, David / Dominic	270 Amherst Street	Nashua	03060	(603) 886-0202
NH	3210	Jenks / Benvenuti, David / Dominic	7 Mill Road #G	Durham	03824	(603) 868-6230
NH	3211	Bell, Keith	1562 Hooksett Road	Hooksett	03106	(603) 836-8100
NH	3212	Bell, Keith	362 Sunapee Street	Newport	03773	(603) 865-1097
NH	3215	Jenks / Benvenuti, David / Dominic	250 Central Avenue	Dover	03820	(603) 742-8411
NH	3216	Jenks / Benvenuti, David / Dominic	556 Nashua Street	Milford	03055	(603) 673-2700
NH	3219	Jenks / Benvenuti, David / Dominic	300 North Main Street	Rochester	03867	(603) 335-5663
NH	3220	Rivard, Robert P.	580 Union Avenue	Laconia	03246	(603) 528-4820
NH	3221	Jenks / Benvenuti, David / Dominic	16 Chase Street	Hudson	03051	(603) 319-1999
NH	3222	Bell, Keith	89 Main Street	West Lebanon	03784	(603) 298-5222
NH	3223	Yeames, Richard C.	212 Fisherville Road	Concord	03303	(603) 228-4221
NH	3225	Jenks / Benvenuti, David / Dominic	725 Lafayette Road	Hampton	03842	(603) 929-0030
NH	3226	Rivard, Robert P.	72 Portsmouth Avenue #120	Stratham	03885	(603) 778-7800
NH	3230	Rivard, Robert P.	458 Daniel Webster Highway, Unit 7	Merrimack	03054	(603) 424-0080
NH	3234	Bahadir, Esra Hamide	900 Central Street	Franklin	03235	(603) 821-4999
NH	3235	Rivard, Robert P.	61 Crystal Avenue	Derry	03038	(603) 432-6605
NH	3241	Bell, Keith	73 South Main Street	Hanover	03755	(603) 643-3344
NH	3244	Rivard, Robert P.	103 Nashua Road	Londonderry	03053	(603) 434-3600
NH	3245	Vaillancourt, Carl E.	553 Mast Road, Unit #108	Goffstown	03045	(603) 932-5555
NH	3249	Hunt, Travis William	13 Pleasant Street, Suite 2	Berlin	03570	(603) 752-2255
NH	3276	Hunt, Travis William	683- 1 Meadow Street	Littleton	03561	(603) 610-4455
NH	3285	Hunt, Travis William	1976 White Mountain Highway, Suite 110A	North Conway	03860	(603) 452-7223
NH	3287	Bell, Keith	1448 Route 119	Rindge	03461	(603) 899-7477
NH	3923	Hunt, Travis William	45 Danville Road	Hampstead	03826	(603) 819-5521
NH	9551	Karakus, Yunus	150 Bridge Street	Pelham	03076	(603) 635-4301
NJ	3358	Ebrahim, Samer S.	578 Avenue C	Bayonne	07002	(201) 858-3030
NJ	3359	Joarder, Mohammed Shamsuzzaman	6002 Main Street	Mays Landing	08330	(609) 757-1000
NJ	3375	Tanoli, Rashid	648 Godwin Avenue, Units 16 & 18	Midland Park	07432	(201) 574-7000

Exhibit B Traditional
as of December 31, 2023

NJ	3378	Khan, Mohammad S.	683 Mt. Prospect Avenue	Newark	07104	(973) 475-8700
NJ	3379	Khan, Mohammad S.	293 1st Street	Jersey City	07302	(201) 333-3322
NJ	3384	Dunn, Clifton William	741A Communipaw Avenue	Jersey City	07304	(201) 536-3030
NJ	3386	Khan, Mohammad S.	933 Main Avenue	Passaic	07055	(862) 234-2323
NJ	3387	Khan, Muhammad Ratib	33 Princeton Highstown Road	Princeton Junction	08550	(609) 897-0888
NJ	3392	Sheikh, Aziz A.	50 Mt. Bethel Road	Warren	07059	(908) 755-5757
NJ	3393	Talwar, Subhash C.	506 Route 70	Lakehurst	08733	(732) 657-7500
NJ	3394	Zaidi, Syed S.	102 Main Street	Sayreville	08872	(732) 613-4200
NJ	3395	Martínez, Wellington	479 Pompton Avenue	Cedar Grove	07009	(973) 521-5547
NJ	3652	Yaqoob, Waqas	219 South Avenue W.	Westfield	07090	(908) 889-1818
NJ	3900	Joarder, Mohammed Shamsuzzaman	401 Harmony Road #23	Gibbstown	08027	(856) 224-8700
NJ	3909	Patei, Nehal M.	629 Springfield Avenue	Berkeley Heights	07922	(908) 898-0009
NJ	3916	Ansari, Massoud	99 Route 23 South	Hamburg	07419	(973) 823-9111
NJ	3917	Joarder, Mohammed Shamsuzzaman	446 S. Broadway	Camden	08103	(856) 225-0400
NJ	3918	Zaidi, Syed S.	942 Radio Road, Unit 7	Little Egg Harbor	08087	(609) 296-2900
NJ	3925	Khan, Shafiq A.	631 Newark Avenue	Jersey City	07306	(201) 721-6338
NJ	3932	Martínez, Wellington	527 High Mountain Road	N. Haledon	07508	(973) 427-0039
NJ	3940	Parmer, Jason M.	905 West Bay Avenue, Unit B	Barnegat	08005	(609) 978-1333
NJ	3941	Ansari, Massoud	244 Newton Sparta Road	Newton	07860	(973) 579-3373
NJ	3942	Joarder, Mohammed Shamsuzzaman	210-212 N. Main Street	Cape May Court House	08210	(609) 465-9090
NJ	3943	Joarder, Mohammed Shamsuzzaman	440 White Horse Pike	Atco	08004	(856) 768-5522
NJ	3944	Khan, Mohammad S.	333 Union Avenue	Rutherford	07070	(201) 933-7900
NJ	3946	Joarder, Mohammed Shamsuzzaman	4 Toms River Road	Jackson Township	08527	(732) 523-3400
NJ	3948	Khan, Mohammad S.	325 Route 10	East Hanover	07936	(973) 428-9400
NJ	3955	Yaqoob, Waqas	116 3rd Avenue	Neptune	07753	(732) 776-8887
NJ	3956	Khan, Mohammad S.	352 Anderson Avenue	Cliffside Park	07010	(201) 945-3700
NJ	3957	Joarder, Mohammed Shamsuzzaman	127 Black Horse Pike	Williamstown	08094	(856) 728-5533
NJ	3958	Beniamien, Malak S.	10 Franklin Avenue	Nutley	07110	(973) 667-2222
NJ	3959	Tanoli, Rashid	13 Overlook Avenue	Rochelle Park	07662	(201) 587-9111
NJ	3960	Martínez, Wellington	1109 Route 23	Wayne	07470	(973) 694-0042
NJ	3961	Khan, Mohammad S.	1068 Bergen Street	Newark	07112	(973) 926-6000
NJ	3963	Dunn, Clifton William	7-11 Smith Street	Paterson	07505	(973) 345-3030
NJ	3965	Joarder, Mohammed Shamsuzzaman	104-B Hickory Corner Road	East Windsor	08520	(609) 443-0888
NJ	3967	Mechael, Sameh M.	25 Route 31, Suite 19	Pennington	08534	(609) 281-8000
NJ	3968	Zaidi, Syed S.	4319 Route 9 South	Howell	07731	(732) 901-7300
NJ	3969	Martínez, Wellington	1360 State Route 23	Butler	07405	(973) 492-9300
NJ	3970	Vahidi, Hadi	340 Ryders Lane	Milltown	08850	(732) 238-6500

Exhibit B Traditional
as of December 31, 2023

NJ	3971	Mechael, Sameh M.	957 Highway 33, Suite 7	Hamilton	08690	(609) 208-0600
NJ	3972	Tanoli, Rashid	98 E Main Street	Ramsey	07446	(201) 934-1234
NJ	3973	Zaidi, Syed S.	415 Route 9 South	Englishtown	07726	(732) 972-3737
NJ	3974	Yaqoob, Waqas	183 1Street Avenue, Unit-A	Atlantic Highlands	07716	(732) 872-2800
NJ	3975	Zaidi, Syed Akhtar	141 US Highway 46	Budd Lake	07828	(973) 691-8900
NJ	3976	Joarder, Mohammed Shamsuzzaman	51 Niagra Street	Newark	07105	(973) 344-3033
NJ	3977	Joarder, Mohammed Shamsuzzaman	127 Ark Road, Unit 5	Mount Laurel	08054	(856) 998-1111
NJ	3979	Ansari, Massoud	538 Livingston Street	Norwood	07648	(201) 784-1111
NJ	3980	Khan, Mohammad S.	447 Central Avenue	Newark	07103	(973) 268-2700
NJ	3981	Ansari, Massoud	127 Main Street	Hackettstown	07840	(908) 813-3030
NJ	3982	Patel, Shobhana D.	245 Rt. 31-202	Flemington	08822	(908) 788-8008
NJ	3984	Ansari, Massoud	135 State Route 27	Edison	08820	(732) 548-3939
NJ	3985	Khan, Mohammad S.	504 Van Houten Avenue	Passaic	07055	(973) 778-4600
NJ	3986	Khan, Mohammad S.	335 Valley Road	West Orange	07052	(973) 325-2020
NJ	3987	Khan, Shafiq A.	524 31st Street	Union City	07087	(201) 319-9000
NJ	3988	Ansari, Massoud	1009 US Highway 46	Ledgewood	07852	(973) 252-1333
NJ	3989	Joarder, Mohammed Shamsuzzaman	188 Kearny Avenue	Kearny	07032	(201) 997-8400
NJ	3990	Ansari, Massoud	2002 State Route 31	Clinton	08809	(908) 638-8400
NJ	3991	Khan, Mohammad S.	16 West Washington Avenue	Washington	07882	(908) 689-2200
NJ	3992	Khan, Muhammad Ratib	61 State Road	Princeton	08540	(609) 688-6870
NJ	3995	Talwar, Subhash C.	133 Route 33	Manalapan	07726	(732) 780-9999
NJ	3999	Beniamien, Malak S.	528 Washington Avenue	Belleville	07109	(973) 751-2222
NJ	4500	Khan, Shafiq A.	3682 John F. Kennedy Boulevard	Jersey City	07307	(201) 714-9600
NJ	4501	Khan, Mohammad S.	1600 East Street Georges Avenue	Linden	07036	(908) 266-6100
NJ	4502	Joarder, Mohammed Shamsuzzaman	650 Route 206	Bordentown Township	08505	(609) 832-3333
NJ	4504	Martinez, Wellington	399 Bloomfield Avenue	Caldwell	07006	(973) 228-6600
NJ	4505	Joarder, Mohammed Shamsuzzaman	6814 Tilton Road	Egg Harbor Twp. (Northfield)	08234	(609) 646-8222
NJ	4506	Joarder, Mohammed Shamsuzzaman	109 Bellevue Avenue	Hammonon	08037	(609) 567-5111
NJ	4507	Joarder, Mohammed Shamsuzzaman	603 Browning Lane	Brooklawn	08030	(856) 754-4000
NJ	4508	Joarder, Mohammed Shamsuzzaman	510 Stokes Road, Suite A	Medford	08055	(609) 451-8888
NJ	4509	Jahangir, Waheed	59 Academy Street	South Orange	07079	(973) 378-7900
NJ	4510	Joarder, Mohammed Shamsuzzaman	149 Haddon Avenue	Westmont	08108	(856) 854-5600
NJ	4511	Witting, Christopher W.	1821 Cinnamonson Avenue	Cinnamonson	08077	(856) 786-0100
NJ	4512	Joarder, Mohammed Shamsuzzaman	1101 N. 2nd Street, Suite 1	Millville	08332	(856) 327-4900
NJ	4513	Joarder, Mohammed Shamsuzzaman	862 Asbury Avenue	Ocean City	08226	(609) 788-3888
NJ	4514	Khan, Mohammad S.	467 Springfield Avenue	Newark	07103	(973) 520-7700
NJ	4515	Joarder, Mohammed Shamsuzzaman	231 Rowan Boulevard	Glassboro	08028	(856) 881-8100

Exhibit B Traditional
as of December 31, 2023

NJ	4516	Joarder, Mohammed Shamsuzzaman	510 East Landis Avenue	Vineland	08360	(856) 794-3030
NJ	4517	Khan, Mohammad S.	1044 Clinton Avenue	Irvington	07111	(973) 399-7500
NJ	4518	Martinez, Wellington	500 McBride Avenue	Woodland	07424	(973) 684-1755
NJ	4519	Joarder, Mohammed Shamsuzzaman	39 North Laurel Street	Bridgeton	08302	(856) 455-6800
NJ	4520	Joarder, Mohammed Shamsuzzaman	9 Cookstown Road	Cookstown	08511	(609) 723-5400
NJ	4521	Khan, Mohammad S.	1090 Elizabeth Avenue	Elizabeth	07201	(908) 355-3996
NJ	4522	Witting, Christopher W.	911 Church Road	Cherry Hill	08002	(856) 482-6610
NJ	4523	McLaughlin, Brad A.	1 Berlin Road	Clementon	08021	(856) 627-3030
NJ	4524	Martinez, Wellington	1670 Highway 35	Middletown	07748	(732) 888-1700
NJ	4525	Joarder, Mohammed Shamsuzzaman	75 Sunset Road	Willingboro	08046	(609) 871-8800
NJ	4526	Joarder, Mohammed Shamsuzzaman	290 S Lenola Road	Maple Shade	08052	(856) 866-1500
NJ	4527	Joarder, Mohammed Shamsuzzaman	42 E. Browning Road	Bellmawr	08031	(856) 931-4100
NJ	4528	Joarder, Mohammed Shamsuzzaman	341 S. Burnt Mill Road	Voorhees	08043	(856) 428-3900
NJ	4530	Khan, Muhammad Ratib	2901 Brunswick Pike	Lawrenceville	08648	(609) 895-1555
NJ	4531	Joarder, Mohammed Shamsuzzaman	954 Parkway Avenue	Ewing	08618	(609) 883-1000
NJ	4532	Joarder, Mohammed Shamsuzzaman	536 Mantua Pike	Woodbury	08096	(856) 845-6444
NJ	4533	Joarder, Mohammed Shamsuzzaman	802 White Horse Pike	Egg Harbor City	08215	(609) 593-9393
NJ	4534	Joarder, Mohammed Shamsuzzaman	4903 Westfield Avenue	Pennsauken	08110	(856) 663-2522
NJ	4535	Joarder, Mohammed Shamsuzzaman	27 N. Maple Avenue, Suite 5	Marlton	08053	(856) 596-5900
NJ	4536	Khan, Mohammad S.	454 Route 519	Phillipsburg	08886	(908) 454-1022
NJ	4537	Khan, Mohammad S.	440 Broad Avenue	Leonia	07605	(201) 944-9199
NJ	4538	Khan, Mohammad S.	337 Main Street	Hackensack	07601	(201) 487-6262
NJ	4539	Khan, Shafiq A.	200 Mill Creek Drive	Secaucus	07094	(201) 371-1000
NJ	4540	Yaqoob, Waqas	115 Highway 35	Eatonville	07724	(732) 389-2300
NJ	4541	Martinez, Wellington	96 Wanaque Avenue	Pompton Lakes	07442	(973) 835-0333
NJ	4542	Ansari, Massoud	448 Rahway Avenue	Woodbridge	07095	(732) 750-3730
NJ	4543	Dunn, Clifton William	317 21st Avenue	Paterson	07501	(973) 370-3030
NJ	4544	Yaqoob, Waqas	60 English Plaza	Red Bank	07701	(732) 530-8300
NJ	4545	Talwar, Subhash C.	540 Park Avenue	Freehold	07728	(732) 577-9400
NJ	4546	Khan, Mohammad S.	284 Valley Boulevard	Woodridge	07057	(201) 804-8181
NJ	4547	Martinez, Wellington	319 Main Street, Unit A-2	Keansburg	07734	(732) 495-5200
NJ	4550	Dunn, Clifton William	462 Newark Street	Hoboken	07030	(201) 656-3030
NJ	4551	Ansari, Massoud	60 Main Street #C	South Boundbrook	08880	(732) 563-0330
NJ	4552	Ansari, Massoud	100 Kinderkamack Road	Westwood	07675	(201) 664-9494
NJ	4553	Vahidi, Hadi	211 Applegarth Road, Unit 106	Monroe	08831	(732) 561-4510
NJ	4554	Dunn, Clifton William	1051 Broadway	Bayonne	07002	(201) 339-3030
NJ	4556	Joarder, Mohammed Shamsuzzaman	182 North Broadway	Pennsville	08070	(856) 895-9999

Exhibit B Traditional
as of December 31, 2023

NJ	4558	Martinez, Wellington			309 A Route 35	Cliffwood	07721	(732) 888-1100
NJ	4559	Martinez, Wellington			1070 Route 34	Matawan	07747	(732) 441-4445
NJ	4561	Joarder, Mohammed Shamsuzzaman			1216 Blackhorse Pike	Glendora	08029	(856) 939-6555
NJ	4562	Joarder, Mohammed Shamsuzzaman			5051 Route 42	Turnersville	08012	(856) 232-3333
NJ	4564	Joarder, Mohammed Shamsuzzaman			680 High Street	Burlington	08016	(609) 387-8400
NJ	4565	Ansari, Massoud			13 Washington Avenue	Dumont	07628	(201) 387-8000
NJ	4566	Ansari, Massoud			26-15 Broadway	Fair Lawn	07410	(201) 796-1111
NJ	4567	Zaidi, Syed S.			3000 Yorktowne Boulevard	Brick	08723	(732) 206-0002
NJ	4568	Zaidi, Syed S.			1580 Lakewood Road, Unit 5	Toms River	08755	(732) 573-7000
NJ	4569	Zaidi, Syed S.			1501 Highway 37 East	Toms River	08753	(732) 929-1818
NJ	4570	Yaqoob, Waqas			4060 Asbury Avenue	Tinton Falls	07753	(732) 361-1649
NJ	4571	Khan, Mohammad S.			199 Littleton Road	Parsippany	07054	(973) 402-0313
NJ	4572	Khan, Mohammad S.			7618 Bergenline Avenue	North Bergen	07047	(201) 662-0600
NJ	4573	Jahangir, Waheed			8 Park Avenue	Madison	07940	(973) 593-0070
NJ	4574	Khan, Mohammad S.			172 Main Street	Ridgefield Park	07660	(201) 293-8990
NJ	4576	Jahangir, Waheed			59 Glenridge Avenue	Montclair	07042	(973) 783-3333
NJ	4577	Khan, Mohammad S.			551 Bloomfield Avenue	Newark	07107	(973) 482-7100
NJ	4578	Khan, Mohammad S.			1303 Centennial Avenue	Piscataway	08854	(732) 712-2000
NJ	4580	Zaidi, Syed S.			1019 Street Georges Avenue	Rahway	07065	(732) 574-2525
NJ	4581	Khan, Mohammad S.			503 Richmond Avenue	Plainfield	07060	(908) 424-1444
NJ	4582	Patel, Dilaver I.			101 North Avenue	Cranford	07016	(908) 272-4000
NJ	4583	Khan, Mohammad S.			609 Westfield Avenue	Elizabeth	07208	(908) 354-4322
NJ	4584	Zaidi, Syed S.			9-15 Lanes Mill Road, Unit #3	Brick	08724	(732) 746-5555
NJ	4585	Zaidi, Syed S.			1903-1905 Morris Avenue	Union	07083	(908) 851-2280
NJ	4586	Khan, Mohammad S.			115 Saint George Avenue	Roselle	07203	(908) 298-0200
NJ	4587	Zaidi, Syed Akhtar			1190 Liberty Avenue	Hillside	07205	(908) 964-3733
NJ	4588	Jahangir, Waheed			41 Park Avenue	Summit	07901	(908) 273-9550
NJ	4589	Ansari, Massoud			230 Morris Avenue	Springfield	07081	(973) 912-9030
NJ	4590	Williams, Joseph A.			4800 New Jersey Avenue	Wildwood	08260	(609) 846-1000
NJ	4591	Jonas, Robert			2200A Bayshore Road	Villas	08251	(609) 886-5800
NJ	4592	Zaidi, Syed S.			1126 US Highway	South Amboy	08857	(732) 795-9000
NJ	4593	Jahangir, Waheed			147 Speedwell Avenue	Morristown	07960	(973) 984-2900
NJ	4594	Sheikh, Aziz A.			534 Lyons Road	Liberty Corner	07938	(908) 280-8200
NJ	4595	Zaidi, Syed S.			2600 Bridge Avenue	Pt. Pleasant	08742	(732) 899-2400
NJ	4596	Ansari, Massoud			430 Market Street, Unit 12	Elmwood Park	07407	(201) 354-1010
NJ	4597	Khan, Mohammad S.			89 West Palisades Avenue	Englewood	07631	(201) 439-8383
NJ	4950	Yaqoob, Waqas			109 Taylor Avenue	Manasquan	08736	(732) 528-7600

Exhibit B Traditional
as of December 31, 2023

NJ	4953	Ansari, Massoud		3201 State Route 27	Franklin Park	08823	(732) 940-6633
NJ	4955	Castellano, Vincent M.		350 Route 46101	Rockaway	07866	(973) 957-2000
NJ	4956	Zaidi, Syed S.		576 New Brunswick Avenue	Parth Amboy	08861	(732) 442-4433
NJ	4958	Joarder, Mohammed Shamsuzzaman		1636 Route 38 E.	Lumberton (Mt. Holly)	08048	(609) 265-1300
NJ	4959	Joarder, Mohammed Shamsuzzaman		807 South Olden Avenue	Hamilton	08610	(609) 392-3200
NJ	4962	Ansari, Massoud		430 US Highway 206	Hillsborough	08844	(908) 874-3035
NJ	4963	Khan, Mohammad S.		1734 E. 2nd Street	Scotch Plains	07076	(908) 322-4311
NJ	4964	Rivas, Noel		931 Main Street	Boonton	07005	(973) 299-6555
NJ	4965	Vahidi, Hadi		55 East Railroad Avenue	Jamesburg	08831	(732) 521-4800
NJ	4966	Joarder, Mohammed Shamsuzzaman		2601 Atlantic Avenue	Atlantic City	08401	(609) 347-0303
NJ	4968	Ansari, Massoud		7 US Highway 206	Raritan	08869	(908) 526-3333
NJ	4970	Dunn, Clifton William		311 West Side Avenue	Jersey City	07305	(201) 422-3030
NJ	4972	Castellano, Vincent M.		28 W. Blackwell Street	Dover	07801	(973) 328-3233
NJ	4973	Vahidi, Hadi		570 Georges Road, Unit #1	North Brunswick	08902	(732) 249-0030
NJ	4974	Yaqoob, Waqas		78 Montgomery Avenue	Long Branch	07740	(732) 571-3733
NJ	4977	Zaidi, Syed S.		2585 Route 516	Old Bridge	08857	(732) 679-4343
NJ	4983	Zaidi, Syed S.		699 Route 9	Bayville	08721	(732) 269-7800
NJ	4984	Joarder, Mohammed Shamsuzzaman		782 Whitehorse Pike	Absecon	08201	(609) 646-8808
NJ	4985	Ansari, Massoud		529 Main Street	Spotswood	08884	(732) 251-5000
NJ	4986	Joarder, Mohammed Shamsuzzaman		100 Lakehurst Avenue	Browns Mills	08015	(609) 893-1600
NJ	4988	Khan, Mohammad S.		443 Main Street	East Orange	07018	(973) 676-4000
NJ	4989	Khan, Mohammad S.		2058 State Route 27 #6C	Edison	08817	(732) 572-1441
NJ	4991	Khan, Mohammad S.		110 Maple Avenue	South Plainfield	07080	(908) 756-3336
NM	6501	Bailey, Brian K.		1763 East University, Suite A	Las Cruces	88001	(575) 522-7700
NM	6502	Bailey, Brian K.		3125 North Main Street	Las Cruces	88001	(575) 528-0900
NM	6507	Nelson, Gordon E.		3575 Highway 528 NE, Bldg. B, Suite #112	Rio Rancho	87144	(505) 771-2020
NM	6509	Bailey, Brian K.		1917 N. Prince	Clovis	88101	(575) 769-3030
NM	6510	Bailey, Brian K.		100 S. White Sands Boulevard	Alamogordo	88310	(575) 434-3030
NM	6511	Bailey, Brian K.		801 West Bender	Hobbs	88240	(575) 393-3030
NM	6512	Bailey, Brian K.		515 W. 1st Street	Portales	88130	(575) 359-2020
NM	6513	Bailey, Brian K.		301 N. Main Street	Belen	87002	(505) 861-3030
NM	6514	Bailey, Brian K.		1717 Sudderth Avenue	Ruidoso	88345	(575) 257-3030
NM	6515	Bailey, Brian K.		3501 East Main Street, Suites G & H	Farmington	87402	(505) 326-9100
NM	6517	Bailey, Brian K.		13110 Central Avenue SE	Albuquerque	87123	(505) 302-3030
NM	6518	Bailey, Brian K.		1625 Rio Bravo Boulevard	Albuquerque	87105	(505) 452-3030
NM	6519	Bailey, Brian K.		5920 Holly Avenue NE	Albuquerque	87113	(505) 343-3030
NM	6520	Bailey, Brian K.		3326 Central Avenue SE	Albuquerque	87106	(505) 262-1662

Exhibit B Traditional
as of December 31, 2023

NM	6521	Bailey, Brian K.	1512 A&B Wyoming Boulevard NE	Albuquerque	87112	(505) 299-8777
NM	6522	Bailey, Brian K.	11028 Montgomery Boulevard NE	Albuquerque	87111	(505) 298-3030
NM	6523	Bailey, Brian K.	5011 Montgomery Boulevard NE, Suite A	Albuquerque	87109	(505) 883-1234
NM	6524	Bailey, Brian K.	1106 Juan Tabo Boulevard NE, Suites K&M	Albuquerque	87123	(505) 257-3030
NM	6525	Bailey, Brian K.	4250 Coors Boulevard SW, Suite 4	Albuquerque	87121	(505) 448-3030
NM	6526	Nelson, Gordon E.	2400 12th Street NW Bldg. C, Suite A	Albuquerque	87104	(505) 345-9936
NM	6527	Nelson, Gordon E.	2415 Southern Boulevard SE, Suite #101	Rio Rancho	87124	(505) 891-2900
NM	6528	Nelson, Gordon E.	6010 Coors Boulevard NW, Suite 1	Albuquerque	87120	(505) 836-7500
NM	6529	Bailey, Brian K.	1500 West Joe Harvey Boulevard	Hobbs	88240	(575) 221-3030
NM	6530	Bailey, Brian K.	1124 S. Union Avenue	Roswell	88203	(575) 622-3030
NM	6531	Bailey, Brian K.	1014 S. Street Francis Drive	Santa Fe	87505	(505) 984-3030
NM	6532	Bailey, Brian K.	220 S. Canal Street	Carlsbad	88220	(575) 887-3030
NM	6533	Bailey, Brian K.	615 W. Santa Fe Avenue	Grants	87020	(505) 876-2323
NM	6534	Bailey, Brian K.	2423 N. Main Street	Roswell	88201	(575) 623-3030
NM	6535	Bailey, Brian K.	910 W Highway 180	Silver City	88061	(575) 534-3030
NM	6536	Bailey, Brian K.	718 S. Gold Avenue	Deming	88030	(575) 544-3232
NM	6537	Bailey, Brian K.	302 S. 1 Street Street	Artesia	88210	(575) 746-3030
NM	6538	Bailey, Brian K.	3471 NM-47	Los Lunas	87031	(505) 565-3030
NM	6539	Bailey, Brian K.	3819 National Parks Highway	Carlsbad	88220	(575) 885-3030
NM	6540	Bailey, Brian K.	3530 Zafarano Drive, Suite C-2	Santa Fe	87507	(505) 473-1672
NM	6541	Bailey, Brian K.	1500 W. 21st Street	Clovis	88101	(575) 268-3030
NM	6542	Bailey, Brian K.	917 N. California	Socorro	87801	(575) 838-1111
NM	6544	Bailey, Brian K.	4208 US Highway 64, Suite 2	Kirtland	87417	(505) 598-5121
NM	6545	Bailey, Brian K.	1622 E. Highway 66, Suites #15 & 16	Gallup	87301	(505) 722-4443
NM	6546	Bailey, Brian K.	611 Mills Avenue	Las Vegas	87701	(505) 425-3030
NM	6548	Bailey, Brian K.	1383 W. Jefferson Avenue	Gallup	87301	(505) 297-3131
NM	6550	Bailey, Brian K.	9550 Sage Rd SW, Suite A103	Albuquerque	87121	(505) 833-3030
NM	6551	Bailey, Brian K.	500 West Broadway	Bloomfield	87413	(505) 632-5576
NM	6552	Bailey, Brian K.	931 N Riverside	Espanola	87532	(505) 753-3030
NM	6553	Bailey, Brian K.	1415 W. Aztec Boulevard, Suite 6	Aztec	87410	(505) 334-8405
NM	6555	Bailey, Brian K.	710-E Paseo Del Pueblo Sur	Taos	87571	(575) 779-3030
NM	6595	Nelson, Gordon E.	6510 Paradise Boulevard NW	Albuquerque	87114	(505) 897-9300
NM	6597	Nelson, Gordon E.	3611 Highway 528 NW, Suite 109	Albuquerque	87114	(505) 890-9999
NM	6891	Bailey, Brian K.	421 Avenida de Mesilla, Suite A	Las Cruces	88005	(575) 525-0900
NM	8099	Nelson, Gordon E.	2115 Vista Oeste NW	Albuquerque	87120	(505) 833-5353
NM	9301	Bailey, Brian K.	108 W. Octagon Bldg. 77 - Base Exchange	Cannon AFB	88103	(575) 784-3033
NM	9302	Bailey, Brian K.	3090 N. Roadrunner Parkway	Las Cruces	88011	(575) 521-3030

Exhibit B Traditional
as of December 31, 2023

NM	9303	Bailey, Brian K.	1940 Old Highway 66, Suite B	Edgewood	87015	(505) 286-3030
NM	9304	Bailey, Brian K.	401 South Main Street	Lovington	88260	(575) 396-3030
NM	9305	Bailey, Brian K.	725 W. Main Street	Farmington	87401	(505) 793-3030
NM	9306	Bailey, Brian K.	Holloman AFB Exchange Express, Bldg #33, 744 First Street	Holloman AFB	88330	(575) 479-3030
NM	9307	Bailey, Brian K.	7849 Tramway Boulevard, Suite D	Albuquerque	87122	(505) 299-3030
NM	9308	Bailey, Brian K.	129 Clayton Road	Raton	87740	(575) 245-3030
NM	9309	Bailey, Brian K.	751 Trinity Drive, Building 2, Suite 206	Los Alamos	87544	(505) 662-3030
NM	9310	Bailey, Brian K.	2505 San Mateo Boulevard NE	Albuquerque	87110	(505) 872-3030
NM	9311	Bailey, Brian K.	2270 Main Street NW	Los Lunas	87031	(505) 865-3030
NM	9312	Bailey, Brian K.	5995 Bataan Memorial West	Las Cruces	88012	(575) 448-3030
NM	9860	Bailey, Brian K.	Exchange Mall Food Court 7901 Gibson Boulevard SE, Building 20176	Kirtland AFB	87117	(505) 289-2900
NV	7400	Kraniger, Mark J.	1145 N. McCarran Boulevard, Suite 113	Sparks	89431	(775) 359-5353
NV	7401	Kraniger, Mark J.	83 W. Plumb Lane	Reno	89509	(775) 323-8080
NV	7402	Kraniger, Mark J.	1675 Robb Drive, Suite 2	Reno	89523	(775) 746-2929
NV	7403	Kearns, David	1060 W. Pioneer Boulevard, Suite 104	Mesquite	89024	(725) 225-1112
NV	7404	Kraniger, Mark J.	801 W. 4th Street	Reno	89503	(775) 433-1455
NV	7407	Riddle, Charles M.	1038 Grass Valley Road, Suite J	Winnemucca	89445	(775) 625-3300
NV	7408	Riddle, Charles M.	250 S Highway 160, Suite B-6	Pahrump	89048	(775) 751-3030
NV	7410	Kraniger, Mark J.	3231 U.S. Highway 50 E	Carson City	89701	(775) 883-7500
NV	7412	Kearns, David	360 North Sandhill Boulevard, Suite C	Mesquite	89027	(702) 346-0123
NV	7413	Riddle, Charles M.	960 Auction Road, Suite A	Fallon	89406	(775) 423-2500
NV	7414	Kraniger, Mark J.	10603 Stead Boulevard, Suite #4	Reno	89506	(775) 677-4545
NV	7416	Riddle, Charles M.	266 Spring Creek Parkway	Spring Creek	89815	(775) 777-3343
NV	7449	Riddle, Charles M.	1014 Old Nevada Highway	Boulder City	89005	(702) 294-2424
NV	7463	Kraniger, Mark J.	465 South Meadows Parkway, Suite #10	Reno	89521	(775) 852-5353
NV	7474	Kraniger, Mark J.	4999 Longley Lane	Reno	89502	(775) 825-3030
NV	7478	Kraniger, Mark J.	4850 Sun Valley Boulevard	Sun Valley	89433	(775) 673-6363
NV	9031	Kraniger, Mark J.	2483 Wingfield Hills Road, Suite 120	Sparks	89436	(775) 626-3030
NV	9032	Riddle, Charles M.	1900 Idaho Street, #101	Eiko	89801	(775) 753-9333
NV	9035	Kraniger, Mark J.	1645-B Highway 395	Minden	86423	(775) 392-4343
NV	9045	Riddle, Charles M.	1510 Newlands Drive E, Suite 2	Ferley	89408	(775) 404-0300
NY	3030	Cookston, Robert L. III	2373 Central Park Avenue	Yonkers	10710	(914) 337-0305
NY	3299	Sharma, Yash P.	886 DeKalb Avenue	Brooklyn	11221	(917) 909-6464
NY	3300	Mahmood, Shahid	3069 Route 9W	Saugerties	12477	(845) 246-3030
NY	3301	Denman, Matthew J.	43 Market Street	Amsterdam	12010	(518) 842-7227
NY	3302	Erwin, Allan F.	198 Hoosick Street	Troy	12180	(518) 273-3030
NY	3303	Mahmood, Shahid	267 New Scotland Avenue	Albany	12208	(518) 438-3030

Exhibit B Traditional
as of December 31, 2023

NY	3304	Erwin, Allan F.	1441 Broadway	Schenectady	12306	(518) 372-4441
NY	3305	Erwin, Allan F.	222 Delaware Avenue	Delmar	12054	(518) 439-2200
NY	3310	Erwin, Allan F.	86 Washington Street	Saratoga Springs	12866	(518) 587-2244
NY	3311	Cookston, Robert L. III	88 North Plank Road	Newburgh	12550	(845) 670-7009
NY	3312	Sharma, Yash P.	364 Bay Street	Staten Island	10301	(718) 273-4848
NY	3313	Sharma, Yash P.	3626 Bell Boulevard	Bayside	11361	(718) 225-7575
NY	3314	Sharma, Yash P.	1785 Victory Boulevard	Staten Island	10314	(718) 208-4900
NY	3315	Cookston, Robert L. III	4697 Third Avenue	Bronx	10458	(877) 883-9643
NY	3316	Khan, Muhammad Riaz	50 Carpenter Avenue, Suite 1	Middletown	10940	(845) 342-4200
NY	3317	Sharma, Yash P.	172 New Dorp Lane	Staten Island	10306	(929) 425-1800
NY	3320	Erwin, Allan F.	19 Clinton Plaza	Oneonta	13820	(607) 432-3033
NY	3321	Cookston, Robert L. III	220 E 161st Street, Ste C	Bronx	10451	(917) 688-3778
NY	3322	Cookston, Robert L. III	315 E 204th Street	Bronx	10467	(718) 734-2666
NY	3324	Cookston, Robert L. III	946 Southern Boulevard	Bronx	10459	(929) 207-0202
NY	3325	Ahmed, MD Shueb	247-22D South Conduit Avenue	Rosedale	11422	(718) 717-8877
NY	3326	Bhuyan, Mili A.	162 Main Street	Brewster	10509	(845) 314-3400
NY	3327	Jara, Giovanni	10 Taft Avenue	Poughkeepsie	12603	(845) 473-5500
NY	3328	Ali, Raja Shahid	2196 Pitkin Avenue	Brooklyn	11207	(718) 495-4441
NY	3329	Sharma, Yash P.	3514 Nostrand Avenue	Brooklyn	11229	(718) 769-3111
NY	3330	Jara, Giovanni	7-G Route 9 West	West Haverstraw	10993	(845) 429-0200
NY	3331	Jara, Giovanni	703 Route 9	Fishkill	12524	(845) 218-0200
NY	3332	Erwin, Allan F.	3155 Delaware Avenue	Kenmore	14217	(716) 800-2121
NY	3333	Cookston, Robert L. III	1468 Westchester Avenue	Bronx	10472	(718) 893-1777
NY	3334	Ahmed, MD Shueb	10950 Merrick Boulevard	Jamaica	11433	(718) 658-4200
NY	3335	Maestri, Anthony	2554 Adam Clayton Powell, Jr. Boulevard	New York	10039	(212) 283-1100
NY	3336	Sharma, Yash P.	815 Onderdonk Avenue	Ridgewood	11385	(718) 326-8686
NY	3337	Cookston, Robert L. III	921 E Tremont Avenue, Suite A	Bronx	10460	(718) 542-4993
NY	3338	Sharma, Yash P.	9528 Queens Boulevard	Rego Park	11374	(718) 896-1717
NY	3339	Cookston, Robert L. III	686C Nereid Avenue	Bronx	10470	(718) 882-4393
NY	3340	Cookston, Robert L. III	2721 Bronxwood Avenue	Bronx	10469	(347) 712-3311
NY	3341	Mohammed, Nur	85-15A Rockaway Beach Boulevard	Rockaway Beach	11693	(718) 791-9900
NY	3342	Cookston, Robert L. III	401 Windsor Highway	New Windsor	12553	(845) 562-0300
NY	3345	Bhuyan, Mili A.	1871 Commerce Street	Yorktown Heights	10598	(914) 352-7200
NY	3347	Cookston, Robert L. III	41 E 167th Street	Bronx	10452	(718) 293-2170
NY	3348	Bhuyan, Mili A.	835 Clarkson Avenue	Brooklyn	11203	(718) 773-7444
NY	3350	Baldwin, Adam P.	936 E. Second Street	Jamestown	14701	(716) 664-3850
NY	3352	Bhuyan, Mili A.	130 North Bedford Road	Mount Kisco	10549	(914) 244-1600

Exhibit B Traditional
as of December 31, 2023

NY	3354	Cookston, Robert L. III	1988 Amsterdam Avenue	New York	10032	(212) 923-3030
NY	3356	Chong, Jacob	3548 West Genesee Street, Suite 2	Syracuse	13219	(315) 488-5402
NY	3357	Baldwin, Adam P.	10506 Bennett Road	Dunkirk	14048	(716) 363-2227
NY	3360	Baldwin, Adam P.	305 E. Fairmount Avenue	Lakewood	14750	(716) 338-9777
NY	3361	Cookston, Robert L. III	791 State Route Rt. 17M	Monroe	10950	(845) 774-7100
NY	3363	Erwin, Allan F.	10207 N. Riva Ridge Loop Bldg P	Ft. Drum	13602	(315) 777-4400
NY	3364	Sharma, Yash P.	8719 Lefferts Boulevard	Richmond Hill	11418	(347) 644-2844
NY	3366	Sharma, Yash P.	1544 Broadway	Brooklyn	11221	(347) 657-7577
NY	3370	Erwin, Allan F.	4395 Union Road	Cheektowaga	14225	(716) 458-8088
NY	3372	Jara, Giovanni	950 Mamaroneck Avenue	Mamaroneck	10543	(914) 630-7222
NY	3374	Erwin, Allan F.	1105 Broadway, Units #11 & #12	Buffalo	14212	(716) 953-3434
NY	3380	Erwin, Allan F.	6405 Dysinger Road	Lockport	14094	(716) 478-7744
NY	3390	Erwin, Allan F.	6031 Transit Road, Suite 104	Clarence	14051	(716) 689-2400
NY	3400	MacPherson, Christopher J.	753 Maple Avenue	Elmira	14904	(607) 732-2203
NY	3401	MacPherson, Christopher J.	311 E. Green Street	Ithaca	14850	(607) 256-4000
NY	3402	MacPherson, Christopher J.	351 Park Avenue	South Corning	14830	(607) 438-2500
NY	3403	MacPherson, Christopher J.	8 Court Street	Cortland	13045	(607) 758-3030
NY	3404	De Busk, Larry	122 Baldwin Street	Johnson City	13790	(607) 798-7177
NY	3405	De Busk, Larry	1185 Vestal Avenue	Binghamton	13903	(607) 772-8555
NY	3406	Erwin, Allan F.	1075 Ridge Road	Webster	14580	(585) 216-3005
NY	3407	Erwin, Allan F.	1460 Lyell Avenue	Rochester	14606	(585) 736-3507
NY	3408	Gray, Gregory E.	19 Dill Street	Auburn	13021	(315) 252-4440
NY	3410	Lee, Michael S.	329 Nottingham Road	Syracuse	13210	(315) 423-0333
NY	3411	Shujaa, Syed	2022 Teall Avenue	Syracuse	13206	(315) 437-3330
NY	3412	Shujaa, Syed	1 Glenwood Avenue	Oneida	13421	(315) 693-3093
NY	3414	Erwin, Allan F.	449 N. Greenbush Road	Rensselaer	12144	(518) 274-3030
NY	3415	Sharma, Yash P.	501 Westbury Avenue	Carle Place	11514	(516) 997-8555
NY	3416	Lee, Michael S.	80 Smokey Hollow Road	Baldwinsville	13027	(315) 303-7001
NY	3417	Lee, Michael S.	6438 Basile Rowe	East Syracuse	13057	(315) 498-1919
NY	3418	MacPherson, Christopher J.	2109 Routes 5 & 20	Seneca Falls	13148	(315) 670-3464
NY	3419	Shujaa, Syed	246 Mohawk Street	Herkimer	13350	(315) 983-3600
NY	3420	Erwin, Allan F.	113 Erie Boulevard W.	Rome	13440	(315) 339-1122
NY	3424	O'Hara, Byron	2443 Route 9, Suite 205	Malta	12020	(518) 282-5100
NY	3425	Erwin, Allan F.	58 West Ninth Street	Oswego	13126	(315) 343-7250
NY	3426	Erwin, Allan F.	516 S. 2nd Street	Fulton	13069	(315) 593-1777
NY	3427	Erwin, Allan F.	2427 Chenango Road	Utica	13502	(315) 735-3030
NY	3429	MacPherson, Christopher J.	1 Exchange Street	Geneva	14456	(315) 789-3090

Exhibit B Traditional
as of December 31, 2023

NY	3430	Erwin, Allan F.	1595 Mt. Hope Avenue	Rochester	14620	(585) 244-2100
NY	3431	Baldwin, Adam P.	5999 South Park Avenue, Suite #900	Hamburg	14075	(716) 941-2023
NY	3434	MacPherson, Christopher J.	252 Oakwood Avenue	Elmira	14903	(607) 846-6888
NY	3435	Erwin, Allan F.	2095 E. Henrietta Boulevard	Rochester	14623	(585) 359-3330
NY	3436	Erwin, Allan F.	205 Main Street	Brockport	14420	(585) 637-6886
NY	3437	Erwin, Allan F.	1699 Culver Road	Rochester	14609	(585) 654-9900
NY	3439	Khan, Muhammad Riaz	156 Dolson Avenue, Unit 8B	Middletown	19040	(845) 801-8400
NY	3440	Erwin, Allan F.	1092 Long Pond Road	Rochester	14626	(585) 227-1500
NY	3441	Cookston, Robert L. III	189 S. Highland Avenue	Ossining	10562	(914) 762-7111
NY	3442	Ali, Raja Shahid	863 W. Jericho Turnpike	Smithtown	11787	(631) 864-8400
NY	3443	Denman, Matthew J.	132 W. Fulton Street	Gloversville	12078	(518) 725-1100
NY	3444	De Busk, Larry	108 Washington Avenue	Endicott	13760	(607) 786-3030
NY	3445	Khan, Muhammad Riaz	38 Lafayette Avenue	Suffern	10901	(845) 368-2255
NY	3447	Erwin, Allan F.	6 Court	Batavia	14020	(585) 343-3344
NY	3448	Ahmed, MD Shueb	10962 Francis Lewis Boulevard	Queens Village	11429	(718) 776-3030
NY	3449	Shek, Mohammed Faruk	608 Broadway	Massapequa	11758	(516) 799-9400
NY	3451	Mahmood, Shahid	779 Broadway	Kingston	12401	(845) 331-3033
NY	3452	Mohammed, Nur	9 Cooper Street	Babylon	11702	(631) 422-2020
NY	3453	Mahmood, Shahid	300 Fairview Avenue	Hudson	12534	(518) 822-0033
NY	3454	Maestri, Anthony	409 West 125th Street	New York	10027	(212) 280-3200
NY	3455	Erwin, Allan F.	785 Fairport Road	East Rochester	14445	(585) 673-7377
NY	3456	Cookston, Robert L. III	3624 Broadway	New York	10031	(212) 926-1234
NY	3457	Erwin, Allan F.	1533 Central Avenue	Albany (aka Colonie)	12205	(518) 452-3030
NY	3458	Khan, Muhammad Riaz	39 S. Main Street	New City	10956	(845) 639-4040
NY	3459	Ali, Raja Shahid	167 Clarke Street	Brentwood	11717	(631) 231-9700
NY	3461	O'Hara, Byron	209-217 Main Street	Hudson Falls	12839	(518) 747-7700
NY	3462	Siddiqui, Imran	1683 Route 9	Halfmoon	12065	(518) 383-8888
NY	3463	Jara, Giovanni	592 Columbus Avenue	New York	10024	(212) 496-5900
NY	3468	Hanley, Christopher M.	2229 Route 112, Unit I	Coram	11727	(631) 736-7878
NY	3469	Cookston, Robert L. III	1265 Montauk Highway, Suite D	Mastic	11950	(631) 399-3030
NY	3470	Ahmed, MD Shueb	15 Village Avenue	Elmont	11003	(516) 696-5555
NY	3471	Bhuyan, Mili A.	111A W. Sunrise Highway	Lindenhurst	11757	(631) 225-7000
NY	3473	Cookston, Robert L. III	1801 New York Avenue	Huntington Station	11746	(631) 673-0100
NY	3474	Sharma, Yash P.	406 North Wantagh Avenue	Bethpage	11714	(516) 942-0808
NY	3476	Erwin, Allan F.	1673 East Main Street	Rochester	14609	(585) 484-8886
NY	3480	Baldwin, Adam P.	2626 W. State Street, Unit 1	Olean	14760	(716) 373-4210
NY	3484	MacPherson, Christopher J.	70 West Avenue	Canandaigua	14424	(585) 396-1230

Exhibit B Traditional
as of December 31, 2023

NY	3485	Erwin, Allan F.	4944 Transit Road	Cheektowaga	14043	(716) 671-3222
NY	3486	Mohammed, Nur	524 Beach 20th Street	Far Rockaway	11691	(718) 337-7100
NY	3487	Gray, Gregory E.	241 E. Union Street	Newark	14513	(315) 331-2250
NY	3488	Cookston, Robert L. III	2050 East Main Street	Cortlandt Manor	10567	(914) 788-0800
NY	3489	Gonzalez, Carlos	158 Old Country Road	Riverhead	11901	(631) 369-9090
NY	3493	Hanley, Christopher M.	781 Horseblock Road	Farmingville	11738	(631) 320-0333
NY	3494	MacPherson, Christopher J.	2104 Grand Central Avenue	Horseheads	14845	(607) 796-2211
NY	3495	Gonzalez, Carlos	260 West Montauk	Hampton Bays	11946	(631) 856-4500
NY	3496	Bhuyan, Mili A.	926 Route Six	Mahopac	10541	(845) 314-1400
NY	3497	Chong, Jacob	240 W. Seneca Street	Manlius	13104	(315) 692-2515
NY	3500	Erwin, Allan F.	1401 Niagara Falls Boulevard	Amherst	14226	(716) 832-4444
NY	3501	Ali, Raja Shahid	55 Third Avenue	Bayshore	11706	(631) 206-0300
NY	3502	Jarvis, Timothy R.	331 Cornelia Street	Plattsburgh	12901	(518) 563-0600
NY	3503	O'Hara, Byron	144 Glen Street	Glens Falls	12801	(518) 793-7777
NY	3505	O'Hara, Byron	820 State Route 9, Suite 1322	Queensbury	12804	(518) 601-2500
NY	3507	Jara, Giovanni	4288 Albany Post Road	Hyde Park	12538	(845) 366-6050
NY	3509	Sharma, Yash P.	136 Woodbury Road	Hicksville	11801	(516) 822-3333
NY	3510	Jara, Giovanni	1817 South Road, Suite C	Wappingers Falls	12590	(845) 296-9660
NY	3511	Jara, Giovanni	153 East 116th Street	New York	10029	(212) 831-1024
NY	3513	Lee, Michael S.	215 N. Main Street	N. Syracuse	13212	(315) 458-6500
NY	3514	Malik, Sanan	117 Mineola Avenue	Roslyn Heights	11577	(516) 484-0440
NY	3515	Khan, Muhammad Riaz	33 E. Central Avenue	Pearl River	10965	(845) 735-0500
NY	3516	Jara, Giovanni	96 Route 59	Spring Valley	10977	(845) 425-0400
NY	3517	Sharma, Yash P.	13857 Queens Boulevard	Jamaica	11435	(718) 739-3334
NY	3519	Gray, Gregory E.	7787 Oswego Road	Liverpool	13090	(315) 622-1000
NY	3520	Erwin, Allan F.	3608 Main Street	Amherst	14226	(716) 427-0800
NY	3521	Sharma, Yash P.	14909 Northern Boulevard	Flushing	11354	(718) 461-6500
NY	3522	Ahmed, MD Shueb	13131 Merrick Boulevard	Jamaica	11434	(718) 723-3000
NY	3523	Sharma, Yash P.	7802 Jamaica Avenue	Woodhaven	11421	(718) 296-0303
NY	3526	Sharma, Yash P.	3217 Junction Boulevard	East Elmhurst	11369	(718) 458-3030
NY	3528	Mohammed, Nur	12521 Rockaway Boulevard	South Ozone Par	11420	(718) 835-3030
NY	3529	Sharma, Yash P.	1300 Hylan Boulevard	Staten Island	10305	(718) 667-1900
NY	3531	Sharma, Yash P.	9045 Corona Avenue	Elmhurst	11373	(718) 457-3030
NY	3534	Ahmed, MD Shueb	475 West Merrick Road	Valley Stream	11580	(516) 561-5555
NY	3535	Sharma, Yash P.	2553 Steinway Street	Astoria	11103	(718) 545-3030
NY	3536	Cookston, Robert L. III	2075 Jerome Avenue	Bronx	10453	(718) 365-3599
NY	3537	Cookston, Robert L. III	3869 White Plains Road	Bronx	10467	(718) 653-4618

Exhibit B Traditional
as of December 31, 2023

NY	3540	Erwin, Allan F.		22070 US Route 11	Watertown	13601	(315) 788-9700
NY	3541	Ali, Raja Shahid		889B Lowell Avenue	Central Islip	11722	(631) 892-2900
NY	3544	Shek, Mohammed Faruk		269 West Park Avenue	Long Beach	11561	(516) 432-1234
NY	3545	Ali, Raja Shahid		1479 Fulton Street	Brooklyn	11216	(718) 221-4800
NY	3550	Cookston, Robert L. III		329 North Central Avenue	Hartsdale	10530	(914) 683-0400
NY	3551	Cookston, Robert L. III		132 Tuckahoe Road	Yonkers	10710	(914) 963-7735
NY	3552	Jara, Giovanni		471 McLean Avenue	Yonkers	10705	(914) 375-5900
NY	3554	Bhuyan, Mili A.		954 Nostrand Avenue	Brooklyn	11225	(718) 778-0110
NY	3555	Jara, Giovanni		574 North Avenue	New Rochelle	10801	(914) 235-8700
NY	3557	Jara, Giovanni		73 Gramatan Avenue	Mt Vernon	10550	(914) 668-3030
NY	3558	Erwin, Allan F.		1592 State Street	Schenectady	12304	(518) 393-3030
NY	3584	Sharma, Yash P.		104 School Street	Glen Cove	11542	(516) 671-6040
NY	3595	Sharma, Yash P.		9614 Metropolitan Avenue	Forest Hills	11375	(718) 793-2024
NY	3596	Sharma, Yash P.		6314 Queens Boulevard	Woodside	11377	(718) 898-3890
NY	3597	Mohammed, Nur		150-29 Cross Bay Boulevard, #3	Howard Beach	11414	(718) 738-2424
NY	3601	Hanley, Christopher M.		1079 Route 25A (aka N. Country Road)	Stony Brook	11790	(631) 751-0330
NY	3602	Erwin, Allan F.		789 New Loudon Road	Latham	12110	(518) 786-0033
NY	3603	Cookston, Robert L. III		262 Boston Post Road	Port Chester	10573	(914) 967-5070
NY	3604	Mohammed, Nur		147 Main Street	Port Washington	11050	(516) 944-5500
NY	3605	Mohammed, Nur		517C Larkfield Road	E. Northport	11731	(631) 269-2690
NY	3607	Bhuyan, Mili A.		853 Long Island Avenue	Deer Park	11729	(631) 242-6771
NY	3609	Cookston, Robert L. III		1017 Jericho Turnpike	New Hyde Park	11004	(516) 775-0254
NY	3612	Sharma, Yash P.		18807 Union Tpke	Fresh Meadows	11366	(718) 776-0330
NY	3616	Cookston, Robert L. III		16 W. 8th Street	New York	10011	(212) 353-3100
NY	3617	Hanley, Christopher M.		2430 Middle Country Road	Centereach	11720	(631) 981-9800
NY	3621	Hanley, Christopher M.		379 Route 25A #A	Rocky Point	11778	(631) 821-3500
NY	3622	Cookston, Robert L. III		440 E. 14th Street	New York	10009	(212) 473-3030
NY	3623	Hanley, Christopher M.		232 E. Main Street	Patchogue	11772	(631) 207-6800
NY	3624	Cookston, Robert L. III		935 Front Street	Uniondale	11553	(516) 538-6666
NY	3625	Rahman, Hafizur		317 Hempstead Avenue	West Hempstead	11552	(516) 483-3030
NY	3626	Bhuyan, Mili A.		2900 Long Beach Road	Oceanside	11572	(516) 764-3030
NY	3628	Bhuyan, Mili A.		103 Fulton Street	Farmingdale	11735	(516) 752-4000
NY	3630	Ali, Raja Shahid		2048 Rockaway Parkway	Brooklyn	11236	(718) 531-0210
NY	3631	Ali, Raja Shahid		1899 Brentwood Road	Brentwood	11717	(631) 436-3000
NY	3633	Sharma, Yash P.		157 Levittown Parkway	Hicksville	11801	(516) 822-0030
NY	3634	Bhuyan, Mili A.		93 W Merrick Road	Freeport	11520	(516) 867-3030
NY	3635	Hanley, Christopher M.		271 Route 25A #10	Mt. Sinai	11766	(631) 744-5200

Exhibit B Traditional
as of December 31, 2023

NY	3636	Cookston, Robert L. III	2150 Bellmore Avenue	Bellmore	11710	(516) 783-3030
NY	3637	Ali, Raja Shahid	5640 Sunrise Highway	Sayville	11782	(631) 567-0600
NY	3639	Hanley, Christopher M.	390 Furrows Road	Holbrook	11741	(631) 585-0990
NY	3640	Bhuyan, Mili A.	775 Flatbush Avenue	Brooklyn	11226	(718) 928-2600
NY	3643	Bhuyan, Mili A.	1772A Ralph Avenue	Brooklyn	11236	(718) 763-7007
NY	3644	Bhuyan, Mili A.	1972 Flatbush Avenue	Brooklyn	11234	(718) 692-2000
NY	3645	Sharma, Yash P.	9105 4th Avenue	Brooklyn	11209	(718) 748-7879
NY	3646	Ali, Raja Shahid	1111 Pennsylvania Avenue	Brooklyn	11207	(718) 272-1212
NY	3647	Sharma, Yash P.	1216 Cortelyou Road	Brooklyn	11218	(718) 692-0900
NY	3649	Sharma, Yash P.	1208 Neptune Avenue	Brooklyn	11224	(718) 265-5600
NY	3650	Sharma, Yash P.	554 5th Avenue	Brooklyn	11215	(718) 972-3733
NY	3651	Bhuyan, Mili A.	1555 Nostrand Avenue	Brooklyn	11226	(718) 826-3030
NY	3653	Sharma, Yash P.	328 Myrtle Avenue	Brooklyn	11205	(718) 522-3733
NY	3654	Sharma, Yash P.	3901 4th Avenue	Brooklyn	11232	(718) 633-3733
NY	3655	Sharma, Yash P.	146 Smith Street	Brooklyn	11201	(718) 596-7000
NY	3656	Sharma, Yash P.	7722 13th Avenue	Brooklyn	11228	(718) 833-9222
NY	3657	Cookston, Robert L. III	3484 Boston Road	Bronx	10469	(718) 671-5155
NY	3659	Cookston, Robert L. III	2025-2027 Westchester Avenue	Bronx	10462	(718) 518-8770
NY	3660	Cookston, Robert L. III	738 Morris Park Avenue	Bronx	10462	(718) 822-6010
NY	3665	Ali, Raja Shahid	77 W. Main Street	East Islip	11730	(631) 277-1300
NY	3667	Cookston, Robert L. III	1351 Webster Avenue	Bronx	10456	(718) 537-4700
NY	3668	Ali, Raja Shahid	241 Rockaway Parkway	Brooklyn	11212	(718) 756-5666
NY	3669	Ali, Raja Shahid	1758 Pitkin Avenue	Brooklyn	11212	(718) 385-4545
NY	3670	Sharma, Yash P.	6410 Amboy Road	Staten Island	10309	(347) 705-7411
NY	3673	Sharma, Yash P.	3902 Richmond Avenue	Staten Island	10312	(718) 227-1900
NY	3675	Bhuyan, Mili A.	42 Station Drive, Space # 2	Wyandanch	11798	(631) 920-6687
NY	3676	Sharma, Yash P.	1430 Richmond Avenue	Staten Island	10314	(718) 370-2000
NY	3677	Cookston, Robert L. III	3025 3rd Avenue	Bronx	10455	(718) 401-3800
NY	3678	Cookston, Robert L. III	3706 E Tremont Avenue	Bronx	10465	(718) 430-9300
NY	3679	Sharma, Yash P.	183 Graham Avenue	Brooklyn	11206	(718) 302-2400
NY	3680	Jara, Giovanni	4797 Broadway	New York	10034	(212) 567-8600
NY	3681	Cookston, Robert L. III	170 W. 23rd Street	New York	10001	(212) 243-5700
NY	3682	Ahmed, MD Shueb	181 Church Street	New York	10007	(212) 566-8888
NY	3683	Cookston, Robert L. III	736 West 181st Street	New York	10033	(212) 781-3700
NY	3684	Cookston, Robert L. III	965 Amsterdam Avenue	New York	10025	(212) 222-2000
NY	3685	Jara, Giovanni	148 West 72nd Street	New York	10023	(212) 501-0200
NY	3686	Cookston, Robert L. III	943 First Avenue	New York	10022	(212) 759-6600

Exhibit B Traditional
as of December 31, 2023

NY	3687	Jara, Giovanni	464 3rd Avenue	New York	10016	(212) 545-0200
NY	3688	Jara, Giovanni	1396 First Avenue	New York	10121	(212) 772-8100
NY	3689	Jara, Giovanni	1841 First Avenue	New York	10128	(212) 996-7800
NY	3691	Cookston, Robert L. III	3611 Kingsbridge Avenue	Bronx	10463	(718) 601-3030
NY	3692	Jara, Giovanni	1993 3rd Avenue	New York	10029	(212) 831-0300
NY	3693	Cookston, Robert L. III	227 W. 40th Street	New York	10018	(212) 944-0400
NY	3694	Cookston, Robert L. III	196 Stanton Street	New York	10002	(212) 677-7776
NY	3695	Ahmed, MD Shueb	45 Catherine Street	New York	10002	(212) 802-4444
NY	3698	Sharma, Yash P.	29 Jackson Avenue	Syosset	11791	(516) 558-5050
OH	1330	Lacefield, Morgan T.	422 Howard Street	Bridgeport	43912	(740) 633-2500
OH	2125	Gfeli, Stephen L.	508 Street Route 58	Wellington	44090	(440) 647-2020
OH	2126	Short, Christopher J.	600 W. Main Street	Batavia	45103	(513) 735-2600
OH	2127	Metro, Louis C.	100 North Main Street	Monroe	45050	(513) 539-2525
OH	2128	Metro, Louis C.	5797 S. State Route 48	Maineville	45039	(513) 494-2020
OH	2129	Short, Christopher J.	110 East Plane Street	Bethel	45106	(513) 734-3500
OH	2130	Jali, Ammar	919 Columbiana Canfield Road	Columbiana	44408	(330) 921-4199
OH	2131	Duvall, Jeffrey S.	2040 Beechmont Avenue	Mt. Washington	45230	(513) 233-3555
OH	2132	Jali, Ammar	5139 Mayfield Road	Lynchurst	44124	(216) 340-0888
OH	2133	Duvall, Jeffrey S.	4110 E. Galbraith Road	Cincinnati	45236	(513) 792-0700
OH	2134	Jali, Ammar	620 East Lincolnway	Minerva	44657	(330) 632-2677
OH	2135	Beach, Harrell W. Jr.	4602-E Mahoning Avenue N.W.	Warren	44483	(330) 847-2007
OH	2136	Short, Christopher J.	708 E. Main Street	West Union	45693	(937) 544-4242
OH	2137	Short, Christopher J.	758 W. Market Street	Akron	44303	(330) 382-5700
OH	2139	Metro, Louis C.	4874 Mercedes Drive	Hamilton	45011	(513) 844-8333
OH	2140	Palmito, Robert	445 Broadway Avenue	Lorain	44052	(440) 961-2303
OH	2142	Short, Christopher J.	309 N. High Street	Mt. Orab	45154	(937) 444-9191
OH	2143	Jordan, Matthew P.	8007 State Street	Garrettsville	44231	(330) 527-0505
OH	2144	Thomas, Benjamin J.	30 S. Xenia Street	Eron	45323	(937) 864-0202
OH	2145	Qureshi, Muhammad Bilal	10001 Chester Avenue, Unit J	Cleveland	44106	(216) 273-1212
OH	2146	Satterwhite, Anthony D.	1036 Ashland Road	Mansfield	44905	(419) 504-3030
OH	2150	Jacobs, Christine L.	16 E. Jefferson Street	Jefferson	44047	(440) 576-3030
OH	2152	Short, Christopher J.	209 S. Broadway Street	Blanchester	45107	(937) 783-4995
OH	2153	Metro, Louis C.	8215 Highland Pointe Drive	West Chester	45069	(513) 777-1830
OH	2157	Short, Christopher J.	5866 Fulton Drive NW	Canton	44718	(330) 966-9999
OH	2160	Johnson, Claude E	1305 South Pennsylvania Avenue	Wellston	45692	(740) 384-4233
OH	2162	Edler, Brian L.	5406 N. Summit Street	Toledo	43611	(419) 776-1111
OH	2163	Short, Christopher J.	2707 Hubbard Road	Madison	44057	(440) 428-5000

Exhibit B Traditional
as of December 31, 2023

OH	2164	Qureshi, Muhammad Bilal	15410 West High Street	Middlefield	44060	(440) 632-5556
OH	2166	Short, Christopher J.	2970 West Market Street	Fairlawn	44333	(330) 864-3133
OH	2167	Johnson, Claude E	1101 Chestnut	Nelsonville	45764	(740) 753-3307
OH	2168	Burkett, Lisa M.	230 West Main Street	Crooksville	43731	(740) 982-0040
OH	2169	Metro, Louis C.	6411 Branch Hill Guinea Pike	Loveland	45140	(513) 677-9700
OH	2170	Short, Christopher J.	1324 Vernon Odum Boulevard	Akron	44320	(330) 539-2333
OH	2171	Palmiotto, Robert	33382 Walker Road, Unit N	Avon Lake	44012	(440) 933-3099
OH	2172	Satterwhite, Anthony D.	6444 Pearl Road	Parma Heights	44130	(440) 885-0334
OH	2173	Johnson, Claude E	44 N. Kennebec Avenue	McConnelsville	43756	(740) 962-6000
OH	2174	Satterwhite, Anthony D.	2077 Locust Street	Canal Fulton	44614	(330) 854-2600
OH	2175	Duvall, Jeffrey S.	11424 Springfield Pike	Cincinnati	45246	(513) 772-3222
OH	2176	Jali, Ammar	16716 Chagrin Boulevard	Shaker Heights	44120	(216) 539-8500
OH	2177	Edler, Brian L.	126 N. Main Street	Fredericktown	43019	(740) 694-7827
OH	2178	Wright, Thomas F.	6430 Winchester Boulevard	Canal Winchester	43310	(614) 834-0777
OH	2179	Lacefield, Morgan T.	516 N. Lincoln	Cadiz	43907	(740) 942-1200
OH	2182	Satterwhite, Anthony D.	7220 Pearl Road	Middleburg Heights	44130	(440) 472-0300
OH	2185	Johnson, Claude E	520 West Street	Caldwell	43724	(740) 732-0732
OH	2186	Lacefield, Morgan T.	146 W. Main Street	Barnesville	43713	(740) 425-9999
OH	2188	Satterwhite, Anthony D.	28 South Main Street	Mt. Gilead	43338	(419) 947-6000
OH	2194	Metro, Louis C.	6780 Goshen Road	Goshen	45122	(513) 722-3300
OH	2196	Edler, Brian L.	98 E. Coshocton	Johnstown	43031	(740) 967-3100
OH	2201	Johnson, Claude E	122 N. Main Street	New Lexington	43764	(740) 342-5141
OH	2202	Johnson, Claude E	1027 W. Hunter Street	Logan	43138	(740) 385-9655
OH	2204	Wright, Thomas F.	1114 N. Memorial Drive	Lancaster	43130	(740) 654-1300
OH	2205	Edler, Brian L.	321 South Main Street	Mt Vernon	43050	(740) 397-3151
OH	2206	Anderson, Patrick J.	604 South Second Street	Coshocton	43812	(740) 622-9345
OH	2207	Burkett, Lisa M.	1645 Maysville Avenue	Zanesville	43701	(740) 455-3161
OH	2208	Burkett, Lisa M.	2347 Maple Avenue	Zanesville	43701	(740) 455-3126
OH	2209	Burkett, Lisa M.	1710 East Pike	Zanesville	43701	(740) 455-3193
OH	2210	Burkett, Lisa M.	738 Wheeling Avenue	Cambridge	43725	(740) 439-3555
OH	2213	Edler, Brian L.	1226 N. 21st Street	Newark	43055	(740) 366-7347
OH	2214	Palmiotto, Robert	306 Beall Avenue	Wooster	44691	(330) 264-9800
OH	2215	Edler, Brian L.	406 South Wheeling Street, Unit E	Oregon	43616	(419) 464-9999
OH	2220	Satterwhite, Anthony D.	1423 Wooster Road	Barberton	44203	(330) 706-0030
OH	2221	Satterwhite, Anthony D.	117 Main Street	Wadsworth	44281	(330) 336-0330
OH	2223	Grandison, James Robert	1026 Water Street	Uhrichsville	44683	(740) 922-5700
OH	2224	Russell, Larry D.	88 E. Iron Avenue	Dover	44622	(330) 343-4434

Exhibit B Traditional
as of December 31, 2023

OH	2225	Jali, Ammar	7100 Lockwood Boulevard	Canfield	44406	(330) 259-7911
OH	2226	Jali, Ammar	30 E. Liberty Street, Suite 3	Hubbard	44425	(930) 568-5005
OH	2227	Wright, Thomas F.	680 Conylus Drive	Pataskala	43062	(740) 927-0088
OH	2229	Short, Christopher J.	1012 Prospect Avenue East	Cleveland	44115	(216) 230-3900
OH	2230	Satterwhite, Anthony D.	627 Claremont Avenue	Ashland	44805	(419) 289-0030
OH	2231	Satterwhite, Anthony D.	144 S. Liberty Street	Gallon	44833	(419) 462-9999
OH	2233	Satterwhite, Anthony D.	625 Lexington Avenue, Suite 1	Mansfield	44907	(419) 756-3030
OH	2234	Jali, Ammar	8486 Mayfield Road	Chesterland	44026	(440) 688-5500
OH	2235	Satterwhite, Anthony D.	359 Trimble Road	Mansfield	44906	(419) 529-6222
OH	2236	Penwell, Jon P.	62 E. Main Street	Shelby	44875	(419) 347-3000
OH	2238	Satterwhite, Anthony D.	420 Seltzer Street	Crestline	44827	(419) 683-4909
OH	2240	Short, Christopher J.	265 West Locust Street	Wilmington	45177	(937) 382-0933
OH	2241	Short, Christopher J.	60 Washington Square #19	Washington Court House	43160	(740) 335-8900
OH	2242	Graves, Susan L.	16-18 Consumer Drive	Chillicothe	45601	(740) 775-4444
OH	2244	Graves, Susan L.	207 Lancaster Pike	Circleville	43113	(740) 477-2541
OH	2245	Short, Christopher J.	203 N. Washington Street	Greenfield	45123	(937) 981-7717
OH	2246	Graves, Susan L.	822 Gay Street	Portsmouth	45662	(740) 354-8866
OH	2247	Short, Christopher J.	132 West Main Street	Hillsboro	45133	(937) 393-9941
OH	2250	Johnson, Claude E	12 Mill Street	Athens	45701	(740) 593-3395
OH	2252	Graves, Susan L.	2109 Washington Boulevard	Belpre	45714	(740) 423-0030
OH	2253	Verma, Sunil Kumar	9224 Darrow Road, Units J & K	Twinsburg	44087	(330) 680-5665
OH	2255	Graves, Susan L.	415 2nd Street	Marietta	45750	(740) 374-9852
OH	2256	Satterwhite, Anthony D.	7210 Memphis Road, Unit B	Cleveland	44144	(216) 413-3224
OH	2257	DePugh, Steve	585 Royal Oak Drive	St. Marys	45885	(419) 394-3357
OH	2258	DePugh, Steve	114 E. Market Street	Celina	45822	(419) 586-8888
OH	2259	Elder, Kodie Lee	128 E Wyandotte	Upper Sandusky	43351	(419) 294-5741
OH	2260	Palmiotto, Robert	81 E. Main Street	Norwalk	44857	(419) 663-3030
OH	2262	Palmiotto, Robert	414 W. Perkins Avenue	Sandusky	44870	(419) 626-3033
OH	2263	Gerber, Joshua R.	215 Myrtle Avenue	Willard	44890	(419) 935-3030
OH	2264	Palmiotto, Robert	4917 Milan Road	Sandusky	44870	(419) 515-6050
OH	2265	Parthemore, Chelisea	500 Main Street	Huron	44839	(419) 433-5494
OH	2267	Elder, Kodie Lee	10 N. Main Street	Kenton	43326	(419) 673-1115
OH	2268	Palmiotto, Robert	5329 Liberty Avenue	Vermillion	44089	(440) 967-0300
OH	2270	Khan, Shariq	120 North Lincoln Avenue	Salem	44460	(330) 277-5536
OH	2271	Graves, Susan L.	3320 Cleveland Avenue, N.W.	Canton	44709	(330) 492-3030
OH	2275	Graves, Susan L.	2825 Sunset Boulevard	Steubenville	43952	(740) 264-5501
OH	2276	Khan, Shariq	1377 Franklin Street	Toronto	43964	(740) 537-3537

Exhibit B Traditional
as of December 31, 2023

OH	2277	Jali, Ammar	4520 Mahoning Avenue	Austintown	44515	(330) 330-8898
OH	2278	DePugh, Steve	1109 Wapakoneta Avenue	Sidney	45365	(937) 507-3131
OH	2279	DePugh, Steve	1756 S. Limestone Street	Springfield	45501	(937) 323-4144
OH	2280	Graves, Susan L.	1200 Jackson Pike	Gallipolis	45631	(740) 446-4040
OH	2281	Lacefield, Morgan T.	212 Eastern Avenue	Woodsfield	43793	(740) 472-1744
OH	2282	Lacefield, Morgan T.	105 Plaza Drive	St. Clairsville	43950	(740) 695-5500
OH	2283	Anderson, Patrick J.	224 E. Canal Street	Newcomerstown	43832	(740) 498-4131
OH	2284	Metro, Louis C.	650 W. State Street	Trenton	45067	(513) 988-6055
OH	2285	Lacefield, Morgan T.	2405 Belmont Street	Bellaire	43906	(740) 676-3900
OH	2286	Taylor, Tony Jay	1311 N. Barron Street	Eaton	45320	(937) 882-3030
OH	2287	Jordan, Matthew P.	10 W. Broad Street	Newton Falls	44444	(330) 872-2011
OH	2288	Metro, Louis C.	9157 Cincinnati-Columbus Road	West Chester	45241	(513) 779-4444
OH	2289	Qureshi, Muhammad Bilal	38033 Euclid Avenue, Suite #6	Willoughby	44094	(440) 951-0300
OH	2291	Schlater, Christopher	1450 Kuntz Road	Dayton	45404	(937) 228-3030
OH	2292	Distin, Brian T.	26063 Detroit Road	Westlake	44145	(440) 892-0030
OH	2294	Davey, Matthew Robert	830 Ohio Pike	Cincinnati	45245	(513) 752-8030
OH	2295	Omlor, Michael V.	1257 Bellefontaine Street	Wapakoneta	45895	(419) 780-9199
OH	2300	Graves, Susan L.	811 W. Main Street	Pomeroy	45769	(740) 992-2124
OH	2301	Edler, Brian L.	2183 N. High Street	Columbus	43201	(614) 297-0030
OH	2303	Edler, Brian L.	2049 Henderson Road	Upper Arlington	43220	(614) 459-0030
OH	2304	Edler, Brian L.	1428 N. High Street	Columbus	43201	(614) 642-2444
OH	2305	Edler, Brian L.	907 E. Dublin-Granville Road	Columbus	43229	(614) 841-0030
OH	2310	Edler, Brian L.	1898 Hard Road	Columbus	43235	(614) 766-0300
OH	2313	Edler, Brian L.	6144 E. Main Street	Columbus	43213	(614) 860-0030
OH	2314	Edler, Brian L.	5684 W. Broad Street	Columbus	43228	(614) 851-0030
OH	2315	Wright, Thomas F.	1027 Hill Road N.	Pickerington	43147	(614) 837-2220
OH	2316	Edler, Brian L.	3554 Broadway	Grove City	43123	(614) 875-8366
OH	2319	Edler, Brian L.	3350 Lockbourne Road	Columbus	43207	(614) 497-1300
OH	2325	Edler, Brian L.	3730 Main Street	Hilliard	43026	(614) 771-1181
OH	2326	Edler, Brian L.	7397 State Route 3, Suite C	Westerville	43082	(614) 823-4040
OH	2327	Edler, Brian L.	1365 Georgesville Road	Columbus	43228	(614) 568-4888
OH	2328	Edler, Brian L.	5864 Westerville Road	Westerville	43081	(614) 891-3030
OH	2329	Qureshi, Muhammad Bilal	33670 Aurora Road	Solon	44139	(440) 248-2030
OH	2330	Edler, Brian L.	90 W. William Street	Delaware	43015	(740) 363-9824
OH	2331	Edler, Brian L.	538 E. Center Street	Marion	43302	(740) 383-3030
OH	2332	Edler, Brian L.	840 Delaware Avenue	Marysville	43040	(937) 642-4111
OH	2334	Thomas, Benjamin J.	331 S. Main Street	New Carlisle	45344	(937) 845-0202

Exhibit B Traditional
as of December 31, 2023

OH	2335	Eidler, Brian L.		8 E. Bridge Street	Dublin	43017	(614) 761-0111
OH	2336	DePugh, Steve		509 S Main Street	Bellefontaine	43311	(937) 592-1005
OH	2337	Metro, Louis C.		3159 Montgomery Road	Loveland	45140	(513) 677-1900
OH	2340	DePugh, Steve		417 W. McCreight	Springfield	45504	(937) 325-5521
OH	2341	DePugh, Steve		227 East Home Road	Springfield	45503	(937) 390-3260
OH	2342	DePugh, Steve		1554 E. Main Street	Springfield	45503	(937) 323-5541
OH	2343	DePugh, Steve		937 W Main Street	Tipp City	45371	(937) 667-8114
OH	2344	Omlor, Michael V.		2400 Harding Highway	Lima	45804	(667) 825-1825
OH	2346	DePugh, Steve		766 Scioto	Urbana	43078	(937) 652-2155
OH	2347	DePugh, Steve		120 N. Sunset Drive, Suite A	Piqua	45356	(937) 778-0242
OH	2348	Wasouf, Yasar N.		937 W. Main Street	Troy	45373	(937) 339-9421
OH	2349	DePugh, Steve		1450 N. Cole Street	Lima	45801	(419) 227-0667
OH	2350	Schlater, Christopher		531 Wilmington Avenue	Dayton	45420	(937) 298-3030
OH	2351	Schlater, Christopher		5391 N. Dixie Drive	Dayton	45414	(937) 275-3030
OH	2352	Schlater, Christopher		6583 Brandt Pike	Dayton	45424	(937) 236-3030
OH	2353	Schlater, Christopher		1219 E. Central Avenue	Miamisburg	45342	(937) 859-3030
OH	2354	Schlater, Christopher		1240 Spinning Road	Dayton	45432	(937) 253-3030
OH	2355	Schlater, Christopher		5293 Cornerstone North Boulevard	Centerville	45440	(937) 433-0968
OH	2356	Schlater, Christopher		5103 Springboro Pike	W. Carrollton	45459	(937) 294-3030
OH	2357	Taylor, Tony Jay		3512 W. Siebenthaler Avenue	Dayton	45406	(937) 278-3030
OH	2359	Schlater, Christopher		128 N. Dixie Drive	Vandalia	45377	(937) 898-7000
OH	2360	Schlater, Christopher		1258 Kaufman Avenue	Fairborn	45324	(937) 878-3030
OH	2361	Schlater, Christopher		3320 Dayton Xenia Road	Beaver Creek	45432	(937) 427-3030
OH	2362	Schlater, Christopher		17 North Allison Avenue	Xenia	45385	(937) 372-9282
OH	2363	Schlater, Christopher		2 N. Smithville Road	Dayton	45403	(937) 258-3030
OH	2364	Schlater, Christopher		885 E. Franklin Street	Centerville	45459	(937) 434-8999
OH	2365	Schlater, Christopher		590 S. Main Street	Englewood	45315	(937) 832-1336
OH	2366	Taylor, Tony Jay		1800 N. Main Street	Dayton	45405	(937) 277-3030
OH	2367	Taylor, Tony Jay		4399 W. 3rd Street	Dayton	45417	(937) 263-3030
OH	2368	Schlater, Christopher		2533 Wilmington Pike	Dayton	45403	(937) 297-3030
OH	2369	Metro, Louis C.		915 N Broadway	Lebanon	45036	(513) 932-1431
OH	2370	Davey, Matthew Robert		6011 Glenway Avenue	Cincinnati	45211	(513) 661-8588
OH	2371	Davey, Matthew Robert		2901 Vine Street	Cincinnati	45219	(513) 751-6262
OH	2372	Taylor, Tony Jay		7764 Colerain, Suite C	Cincinnati	45239	(513) 521-8001
OH	2373	Duvall, Jeffrey S.		7720 Laurel Avenue	Madeira	45243	(513) 271-3030
OH	2375	Duvall, Jeffrey S.		3915 Montgomery	Norwood	45212	(513) 396-7400
OH	2377	Duvall, Jeffrey S.		3250 Brotherton Road	Cincinnati	45209	(513) 321-7770

Exhibit B Traditional
as of December 31, 2023

OH	2379	Short, Christopher J.		8460 Beechmont Avenue	Cincinnati	45245	(513) 474-3601
OH	2380	Metro, Louis C.		4600 Roosevelt Boulevard	Middletown	45044	(513) 423-1212
OH	2381	Metro, Louis C.		975 Symmes Avenue	Fairfield	45014	(513) 939-2333
OH	2382	Metro, Louis C.		1199 Main Street	Hamilton	45013	(513) 863-4004
OH	2383	Metro, Louis C.		1987 S. Erie Boulevard	Hamilton	45011	(513) 863-1500
OH	2384	Metro, Louis C.		606 N. University Boulevard	Middletown	45042	(513) 422-2700
OH	2387	DePugh, Steve		2400 Cable Court	Lima	45805	(419) 222-3030
OH	2389	Metro, Louis C.		205 N. Main Street	Springboro	45066	(937) 748-2212
OH	2391	Metro, Louis C.		1008 E. Second Street	Franklin	45005	(937) 746-0256
OH	2396	Schlater, Christopher		431 S. Locust Street, Suite 104	Oxford	45056	(513) 524-6262
OH	2401	Graves, Susan L.		1413 S. Water Street	Kent	44240	(330) 673-6360
OH	2402	Omlor, Michael V.		215 E. Wooster Street #8	Bowling Green	43402	(419) 353-6342
OH	2403	Qureshi, Muhammad Bilal		25 E. Main Street	Orwell	44076	(440) 437-3030
OH	2404	Short, Christopher J.		730 E. Market Street	Akron	44305	(330) 376-2223
OH	2406	Elder, Brian L.		806 N. Main Street	Findlay	45840	(419) 423-3333
OH	2407	Elder, Brian L.		1909 Tiffin Avenue	Findlay	45840	(419) 424-0000
OH	2411	Elder, Brian L.		327 S. Main Street	Bryan	43506	(419) 519-9999
OH	2412	Elder, Brian L.		1804 E. Perry Street	Port Clinton	43452	(419) 960-2992
OH	2414	Elder, Brian L.		240 W. Alexis, Unit E	Toledo	43612	(419) 386-0000
OH	2418	Omlor, Michael V.		301 Towne Center Boulevard	Van Wert	45891	(419) 232-2640
OH	2420	Omlor, Michael V.		847 S. Clinton Street	Defiance	43512	(419) 782-2383
OH	2422	Qureshi, Muhammad Bilal		4908-A Turney Road	Garfield Heights	44125	(216) 353-3500
OH	2430	Davey, Matthew Robert		5083 Delhi Pike	Cincinnati	45238	(513) 451-8880
OH	2431	Duvall, Jeffrey S.		8834 Reading Road	Reading	45215	(513) 821-1700
OH	2432	Short, Christopher J.		605 Mt. Orab Pike	Georgetown	45121	(937) 378-9191
OH	2434	Davey, Matthew Robert		3725 Warsaw Avenue	Cincinnati	45205	(513) 921-9700
OH	2435	Phelps, Richard W.		1166 Harrison Avenue	Harrison	45030	(513) 367-5800
OH	2436	Elder, Brian L.		1830 W. State Street	Fremont	43420	(419) 332-2233
OH	2439	Short, Christopher J.		226 Broad Street	Conneaut	44030	(440) 599-8800
OH	2441	Satterwhite, Anthony D.		758 S. Canton Road	Akron	44312	(330) 362-1999
OH	2444	Palmiotto, Robert		580 Chestnut Commons Drive	Elyria	44035	(440) 323-9050
OH	2446	Satterwhite, Anthony D.		4037 South Main Street	Akron	44319	(330) 245-1444
OH	2448	Qureshi, Muhammad Bilal		20950 Libby Road, Unit 605	Maple Heights	44137	(216) 478-0220
OH	2450	Distin, Brian T.		25044 Lorain Road	North Olmsted	44070	(440) 734-2922
OH	2451	Palmiotto, Robert		21154 Lorain Road	Fairview Park	44126	(440) 333-5544
OH	2453	Satterwhite, Anthony D.		One Berea Commons #2	Berea	44017	(440) 891-0030
OH	2454	Satterwhite, Anthony D.		15034 Pearl Road	Strongsville	44136	(440) 572-0444

Exhibit B Traditional
as of December 31, 2023

OH	2456	Short, Christopher J.	10803 Lorain Avenue	Cleveland	44111	(216) 941-0300
OH	2458	Distin, Brian T.	14212 Detroit Avenue	Lakewood	44107	(216) 221-0030
OH	2461	Satterwhite, Anthony D.	4319 Lorain Avenue	Cleveland	44113	(216) 851-8700
OH	2462	Palmiotto, Robert	2229 Kresge Drive	Amherst	44001	(440) 960-1898
OH	2464	Qureshi, Muhammad Bilal	7250 Center Street	Mentor	44060	(440) 290-9991
OH	2467	Palmiotto, Robert	35108 Center Ridge Road	North Ridgeville	44039	(440) 327-0227
OH	2469	Metro, Louis C.	311 Reading Road	Mason	45040	(513) 398-0046
OH	2474	Stephens, Traven Lee	302 E. Main Street	Ravenna	44266	(330) 296-5559
OH	2476	Short, Christopher J.	1937 W. State Street	Alliance	44601	(330) 680-7900
OH	2477	Jali, Ammar	3065 Belmont Avenue	Liberty Township	44505	(330) 779-1055
OH	2482	Brown, Lance A.	9380 State Route 43	Streetsboro	44241	(330) 626-5999
OH	2485	Short, Christopher J.	5817 Main Avenue	Ashtabula	44004	(440) 992-6060
OH	2486	Metro, Louis C.	1126 State Route 131	Milford	45150	(513) 831-1234
OH	2488	Wilcox, Gerald D.	51 W. Walnut Street	Painesville	44077	(440) 352-6900
OH	2489	Short, Christopher J.	164 N. Broadway	Geneva	44041	(440) 466-6060
OH	2496	Jali, Ammar	425 Water Street, Unit 303A	Chardon	44024	(440) 226-3630
OH	2497	Eidler, Brian L.	22021 Coshocton Road	Howard	43028	(740) 392-3030
OH	2609	Graves, Susan L.	5079 North Hamilton Road	Gahanna	43230	(614) 471-2222
OH	2628	Verma, Sunil Kumar	419 W. Aurora Road	Sagamore Hills	44067	(330) 468-6921
OH	2629	Graves, Susan L.	849 W. Maple Street	Hartsville	44632	(330) 877-1111
OH	2669	Graves, Susan L.	520 West Main Street	Louisville	44641	(330) 875-5555
OH	2676	Eidler, Brian L.	553 W. Main Street	Plain City	43064	(614) 358-2888
OH	2677	Eidler, Kodie Lee	240 W. Market	Tiffin	44883	(419) 447-4992
OH	2678	Duvall, Jeffrey S.	9182 Winton Road	Cincinnati	45231	(513) 521-0301
OH	2679	Palmiotto, Robert	139 Hostetler	Orrville	44667	(330) 682-5000
OH	2681	Duvall, Jeffrey S.	28 W. 4th Street	Cincinnati	45202	(513) 241-4900
OH	2682	Graves, Susan L.	4140 Tuscarawas Street W.	Canton	44708	(330) 477-9999
OH	2683	Graves, Susan L.	147 Northwest Avenue	Tallmadge	44278	(330) 634-0000
OH	2684	DePugh, Steve	515 Wagner Avenue	Greenville	45331	(937) 459-4178
OH	2685	Graves, Susan L.	155 Lincoln Way W., Suite 111-B	Massillon	44647	(330) 830-8888
OH	2686	Eidler, Brian L.	1000 Hebron Road	Heath	43056	(740) 527-3700
OH	2687	Eidler, Brian L.	342 E. Gay Street	Columbus	43215	(614) 384-0330
OH	2688	Graves, Susan L.	4963 Darrow Road, Suite 200	Stow	44224	(330) 342-3030
OH	2689	Satterwhite, Anthony D.	7406 Broadview Road	Parma	44134	(216) 236-6933
OH	2691	Eidler, Brian L.	1035 Polaris Parkway	Columbus	43240	(614) 384-0555
OH	2692	Palmiotto, Robert	5322 Cobblestone Road	Sheffield Village	44035	(440) 934-0909
OH	2693	Palmiotto, Robert	3868 Center Road	Brunswick	44212	(330) 220-0001

Exhibit B Traditional
as of December 31, 2023

OH	2694	Palmiotto, Robert	1209 North Court Street	Medina	44256	(330) 722-1003
OH	2695	Palmiotto, Robert	155 South Main Street	Oberlin	44074	(440) 774-3033
OH	2696	Johnson, Claude E	527 5th Street	Beverly	45715	(740) 984-1700
OH	2697	Omlor, Michael V.	154 E. South Boundary, Suite 10	Perrysburg	43551	(419) 874-9929
OH	9750	Edler, Brian L.	3323 East Broad Street	Columbus	43213	(614) 586-8988
OH	9751	Metro, Louis C.	368 S. Main Street	Waynesville	45068	(513) 855-3330
OH	9752	Taylor, Tony Jay	9918 Colerain Avenue	Cincinnati	45251	(513) 923-9900
OH	9753	Edler, Brian L.	5358 Airport Highway	Toledo	43615	(419) 381-6881
OH	9754	Edler, Brian L.	1440 Secor Road, Suite 120J	Toledo	43607	(419) 578-3330
OH	9755	Jali, Ammar	813 Boardman Poland Road	Boardman	44512	(330) 953-3100
OH	9756	Khan, Shariq	16041 ST Route 170, Suite 2	Calcutta	43920	(330) 932-1050
OH	9757	Short, Christopher J.	23910 Lakeshore Boulevard	Euclid	44123	(216) 815-0911
OH	9759	Graves, Susan L.	1082-1084 Eagleton Boulevard	London	45402	(740) 852-5555
OH	9760	Edler, Brian L.	2185 Riverside Drive	Columbus	43221	(614) 826-6888
OH	9761	Omlor, Michael V.	2256 Scott Street	Napoleon	43545	(567) 264-4208
OH	9765	Graves, Susan L.	2110 State Road	Cuyahoga Falls	44223	(330) 923-3030
OH	9766	Qureshi, Muhammad Bilal	1994 Warrenville Center	South Euclid	44121	(216) 302-7473
OH	9767	Duvall, Jeffrey S.	4774 Cornell Road	Blue Ash	45241	(513) 818-4388
OH	9768	Edler, Brian L.	2350 W. Laskey Road	Toledo	43613	(419) 481-9888
OH	9769	Edler, Brian L.	6819 Central Avenue	Sylvania	43617	(419) 540-4888
OH	9770	Qureshi, Muhammad Bilal	38 South Aurora Road, Unit D	Aurora	44202	(330) 954-9594
OH	9771	Lowery, Kurtis Scott	5580 Youngstown Warren Road, Suite 5	Niles	44446	(330) 544-0000
OH	9772	Edler, Brian L.	6928 East Broad Street	Columbus	43213	(614) 845-0700
OH	9773	Edler, Brian L.	2801 Woodville Road	Northwood	43619	(567) 343-6200
OH	9774	Edler, Brian L.	255 W. South Street	Fosteria	44830	(419) 435-5000
OK	1573	Fernandez, Makayla Rashelle	3671 N. Lottie Avenue	Oklahoma City	73111	(405) 698-3615
OK	6330	Dolan, Charles S.	6025 W. Reno Avenue, Suite B	Oklahoma City	73127	(405) 730-9003
OK	6374	Lessert, Kelly Wade	335 S. Mustang Road, Suite F	Yukon	73099	(405) 805-3199
OK	6400	Loehr, Michael Anthony	806 North Highway 81	Duncan	73533	(580) 255-2555
OK	6401	Mekonnen, Mac A.	2019 S.E. Washington	Idabel	75745	(580) 376-4040
OK	6402	Loehr, Michael Anthony	1116 W. Gore Boulevard	Lawton	73501	(580) 357-0484
OK	6403	Loehr, Michael Anthony	2615 NW Cache Road	Lawton	73505	(580) 248-7480
OK	6409	Loehr, Michael Anthony	806 South 4th Street	Chickasha	73018	(405) 222-5212
OK	6410	Loehr, Michael Anthony	813 E. Broadway Street	Altus	73521	(580) 482-8120
OK	6411	Wills, Orville D.	11560 N. 135th E. Avenue, Suite 101-C	Owasso	74055	(918) 553-1127
OK	6412	Hall, John E. II	301 S. Lynn Riggs Boulevard	Claremore	74017	(918) 341-5555
OK	6420	Dolan, Charles S.	5101 SE 29th Street	Del City	73115	(405) 670-5767

Exhibit B Traditional
as of December 31, 2023

OK	6421	Burgat, Linda J.			2724 N. Pennsylvania Avenue	Oklahoma City	73107	(405) 525-8300
OK	6422	Dolan, Charles S.			9356 S. Western Avenue, Suite D	Oklahoma City	73139	(405) 692-0303
OK	6423	Lessert, Kelly Wade			1426 W. Gary Boulevard	Clinton	73601	(580) 331-6272
OK	6424	Anderson, William			1913 S. Green Avenue	Purcell	73080	(405) 442-0333
OK	6425	Anderson, William			310 S. Chickasaw Street, Unit A	Paul's Valley	73075	(405) 926-8130
OK	6426	Lessert, Kelly Wade			3445 W. Memorial Road, Suite A	Oklahoma City	73134	(405) 755-3030
OK	6427	Hall, John E. II			5315 S. Mill Street	Pryor	74361	(918) 981-8325
OK	6428	Opie, Allen J.			7743 W. Hefner Road	Oklahoma City	73162	(405) 728-8864
OK	6429	Dolan, Charles S.			2929 S. Meridian	Oklahoma City	73108	(405) 688-4349
OK	6430	Opie, Allen J.			16325 N. May Avenue, Suite A-10	Edmond	73013	(405) 513-5989
OK	6431	Wills, Orville D.			17 E. 34th Street	Sand Springs	74063	(918) 241-4444
OK	6432	Hall, John E. II			7020 E. Admiral Place	Tulsa	74115	(918) 747-3030
OK	6435	Lessert, Kelly Wade			120 W. Vandament Avenue, Suite A & Suite B	Yukon	73099	(405) 350-1451
OK	6436	Dolan, Charles S.			3360 S. Harrah Road	HARRAH	73045	(405) 817-0010
OK	6439	Dolan, Charles S.			1262 N. Interstate Drive	Norman	73072	(405) 573-2000
OK	6440	Dolan, Charles S.			1236 Alameda Street, Suite 200	Norman	73071	(405) 329-8181
OK	6441	Mekonnen, Mac A.			511 South Park Drive, Suite B	Broken Bow	74728	(580) 306-9500
OK	6443	Dolan, Charles S.			115 & 117 S. Eastern Avenue	Moore	73160	(405) 793-1988
OK	6444	Hall, John E. II			13601 S. Higway 75	Glenpool	74033	(918) 528-5770
OK	6445	Dolan, Charles S.			1325 SW 44th Street	Oklahoma City	73119	(405) 681-9525
OK	6446	Dolan, Charles S.			1514 SE 44th Street, Suite A	Oklahoma City	73129	(405) 670-6000
OK	6447	Dolan, Charles S.			859 W. State Highway 152	Mustang	73064	(405) 806-7500
OK	6448	Hall, John E. II			1204 W. Danforth Road	Edmond	73003	(405) 340-0300
OK	6450	Mekler, John T.			201 N. Commerce, Suite A	Ardmore	73401	(580) 226-6330
OK	6451	Jones, Robert W.			1600 N. Kickapoo Street	Shawnee	74804	(405) 878-0880
OK	6452	Mekler, John T.			908 Arlington Center	Ada	74820	(580) 436-5361
OK	6453	Mekler, John T.			1200B East Carl Albert Parkway	Mcalester	74501	(918) 426-6410
OK	6454	Mekler, John T.			1436 W. University Boulevard	Durant	74701	(580) 924-1350
OK	6455	Dolan, Charles S.			7114 SE 15th Street	Midwest City	73110	(405) 733-5224
OK	6456	Burgat, Linda J.			4401 N. MacArthur Boulevard, Suite A	Warr Acres	73122	(405) 495-3013
OK	6457	Loehr, Michael Anthony			6412 NW Cache Road	Lawton	73501	(580) 771-3800
OK	6458	Opie, Allen J.			7115 NW 150th, Suite 7	Oklahoma City	73142	(405) 673-1099
OK	6459	Dolan, Charles S.			1000 North Council Road	Blanchard	73010	(405) 320-9700
OK	6460	Hall, John E. II			1524 North Boomer	Stillwater	74075	(405) 624-3030
OK	6461	Lessert, Kelly Wade			506 S.14th Street	Ponca City	74601	(580) 765-5305
OK	6465	Lessert, Kelly Wade			1119 S. Van Buren Street	Enid	73703	(580) 242-2004
OK	6467	Wills, Maria D.			5108 W. 33rd Street	Tulsa	74107	(918) 446-4444

Exhibit B Traditional
as of December 31, 2023

OK	6468	Landthrip, William Mack Jr.		5141 S. Lewis	Tulsa	74105	(918) 571-9988
OK	6469	Hall, John E. II		2216 W. Houston Street	Broken Arrow	74012	(918) 251-3030
OK	6470	Lessert, Kelly Wade		2121 E. Main Street, Suite 6	Weatherford	73096	(580) 302-5200
OK	6471	Hall, John E. II		3151 S. Garnett	Tulsa	74146	(918) 438-5333
OK	6472	Hall, John E. II		2 W. 3rd Street	Grove	74344	(918) 791-0202
OK	6473	Hall, John E. II		3866 S. Sheridan Road	Tulsa	74145	(918) 921-3465
OK	6474	Hall, John E. II		8611 S. Lewis Avenue	Tulsa	74137	(918) 298-3030
OK	6475	Hall, John E. II		16 W. 4th Street	Tulsa	74103	(918) 582-3030
OK	6476	Willis, Maria D.		1 N. Mission Street	Sapulpa	74066	(918) 224-4444
OK	6477	Landthrip, William Mack Jr.		3090 N. Broadway Street, Suite 100	Poteau	74953	(918) 721-0330
OK	6478	Hall, John E. II		3800 Tuxedo Boulevard	Bartlesville	74006	(918) 335-1300
OK	6480	Mekler, John T.		603 E. Okmulgee	Muskogee	74403	(918) 682-5888
OK	6481	Jones, Robert W.		522 N Mill Phillips Street	Seminole	74868	(405) 584-4544
OK	6482	Jones, Robert W.		1004 S. Muskogee Avenue	Tahlequah	74464	(918) 207-1444
OK	6485	Hall, John E. II		620 W. New Orleans Street	Broken Arrow	74012	(918) 957-5418
OK	6486	Hall, John E. II		1002 W. Cherokee	Wagoner	74467	(918) 201-4185
OK	6487	Willis, Maria D.		7703 N. Owasso Expressway, Suite 1	Owasso	74055	(918) 272-1144
OK	6488	Hall, John E. II		7201 S. Memorial Drive	Tulsa	74133	(918) 481-6030
OK	6490	Hall, John E. II		1408 S. Harvard Avenue	Tulsa	74112	(918) 747-6600
OK	6498	Hall, John E. II		13355 S. Memorial Drive	Bixby	74008	(918) 369-3500
OK	6499	Dolan, Charles S.		1337 E. State Highway 152, Suite #119	Mustang	73064	(405) 745-6900
OK	9650	Lessert, Kelly Wade		13520 N. Eastern Avenue, Suite A	Oklahoma City	73131	(405) 478-7400
OK	9651	Elwell, Emily E.		1315 N. Main Street	Miami	74354	(918) 542-4000
OK	9652	Fernandez, Makayla Rashelle		7615 N. May Avenue	Oklahoma City	73116	(405) 673-5550
OK	9653	Dolan, Charles S.		300 E. Main Street	Oklahoma City	73104	(405) 212-5275
OK	9654	Dolan, Charles S.		9205 NE 23rd Street	Midwest City	73141	(405) 437-0032
OK	9655	Jones, Robert W.		1805 S. Country Club Road	El Reno	73036	(405) 778-2143
OK	9656	Hall, John E. II		2222 E. 61st Street	Tulsa	74136	(918) 794-9444
OK	9657	Dolan, Charles S.		819 SW 19th Street, Suite 100	Moore	73160	(405) 759-8825
OK	9658	Hall, John E. II		1110 S. Wood Drive	Okmulgee	74447	(918) 756-1700
OK	9659	Dolan, Charles S.		3056 S. Classen Boulevard, Unit A	Norman	73071	(405) 928-0029
OK	9660	Lessert, Kelly Wade		1726 South Division Street	Guthrie	73044	(405) 282-2410
OK	9662	Lessert, Kelly Wade		1129 West Willow	Enid	73703	(580) 297-5310
OK	9663	Jones, Robert W.		1029 W. Third Street	Elk City	73644	(580) 303-7888
OK	9664	Hall, John E. II		2550 E. Kenosha Street	Broken Arrow	74014	(918) 615-3315
OK	9665	Anderson, William		659 NW 32nd Street	New Castle	73065	(405) 852-2134
OK	9666	Dolan, Charles S.		1654 S Choctaw Road, Suite 101	Choctaw	73020	(405) 281-4050

Exhibit B Traditional
as of December 31, 2023

OR	7109	Ashdown, Jeremy			8040 N. Lombard Street	Portland	97203	(503) 894-7577
OR	7200	Howard, Brian W.			779 W. Central Avenue	Sutherlin	97479	(541) 459-0257
OR	7201	Hamilton, Troy C.			2455 NW Monroe Avenue	Convallis	97330	(541) 758-3030
OR	7202	Hamilton, Troy C.			310 Main Street E.	Monmouth	97361	(503) 836-9500
OR	7203	Vandenber, Bruce M.			4384 River Road N.	Keizer	97303	(503) 390-7712
OR	7204	Vandenber, Bruce M.			3223 Silverton Road N.E.	Salem	97301	(503) 585-8700
OR	7205	Hamilton, Troy C.			2409 Pacific Boulevard	Albany	97321	(541) 917-3344
OR	7206	Hamilton, Troy C.			17531 SW Tualatin Valley Highway	Beaverton	97007	(503) 649-3030
OR	7207	Hamilton, Troy C.			10081 SW Nimbus Avenue	Beaverton	97008	(503) 626-3030
OR	7208	Hammer, Timothy R.			3402 Commercial Street SE	Salem	97302	(503) 364-8875
OR	7209	Vandenber, Bruce M.			411 Lancaster Drive NE	Salem	97301	(503) 362-3030
OR	7210	Vandenber, Bruce M.			4105 Main Street	Springfield	97478	(541) 255-2202
OR	7211	Vandenber, Bruce M.			2621 Williamette Street	Eugene	97405	(541) 343-3030
OR	7212	Vandenber, Bruce M.			1965 River Road	Eugene	97404	(541) 461-0842
OR	7213	Vandenber, Bruce M.			1812 5th Street	Springfield	97477	(541) 746-3030
OR	7214	Poe, Dennis			804 E. 2nd Street	The Dalles	97058	(541) 296-7000
OR	7215	Poe, Dennis			2025 Cascade Avenue, Suite 102	Hood River	97031	(541) 386-7600
OR	7216	Vandenber, Bruce M.			1690 Coburg Road	Eugene	97401	(541) 255-2284
OR	7217	Hamilton, Troy C.			10200 SW Park Way	Portland	97225	(503) 203-1233
OR	7218	Hamilton, Troy C.			1991 NE Cornell Road, Suite 110	Hillsboro	97124	(503) 844-7000
OR	7219	Hamilton, Troy C.			13815 SW Pacific Highway, Suite 10	Tigard	97223	(503) 639-3300
OR	7220	Vandenber, Bruce M.			3540 West 11th Avenue	Eugene	97402	(541) 844-3555
OR	7221	Marx, Bryan William			174 NE Combs Flat Road, Suite 101	Prineville	97754	(458) 231-8001
OR	7222	Kasuba, Tina K.			717 East 1st Street	Newberg	97132	(503) 538-7777
OR	7223	Vandenber, Bruce M.			383 North Pacific Highway	Woodburn	97071	(503) 981-3718
OR	7224	Vandenber, Bruce M.			17302 NE Halsey	Gresham	97230	(971) 277-2100
OR	7225	Poe, Dennis			115 Engle Avenue	Molalla	97038	(971) 444-6555
OR	7226	Farmer, Patrick D.			14621 SE McLoughlin Boulevard	Milwaukie	97267	(503) 659-4950
OR	7227	Vandenber, Bruce M.			3508 SE 122nd Avenue, Unit 3508	Portland	97236	(971) 394-0333
OR	7228	Poe, Dennis			1495 SW Highway 97	Madras	97202	(541) 546-1555
OR	7229	Farmer, Patrick D.			1981 SW 4th Avenue	Portland	97201	(503) 221-1556
OR	7230	Ashdown, Jeremy			4908 N Lombard	Portland	97203	(503) 285-4691
OR	7231	Farmer, Patrick D.			2020 SE Division	Portland	97202	(503) 231-4352
OR	7232	Vandenber, Bruce M.			1600 SE 122nd Avenue	Portland	97233	(503) 253-4848
OR	7233	Vandenber, Bruce M.			3545 NE 82nd Avenue	Portland	97220	(503) 249-6986
OR	7234	Farmer, Patrick D.			10586 SE 32nd Avenue	Milwaukie	97222	(503) 659-5585
OR	7235	Hausinger, Joseph Allan			4103 SE 82nd Avenue	Portland	97266	(503) 774-9855

Exhibit B Traditional
as of December 31, 2023

OR	7236	Farmer, Patrick D.		3622 NE Sandy Boulevard	Portland	97232	(503) 284-5666
OR	7237	Kealer, Scott A.		10075 SW Barbur Boulevard, Suite 7	Portland	97219	(971) 350-0808
OR	7238	Poe, Dennis		6922 NE Glisan	Portland	97213	(503) 252-7700
OR	7239	Vandenbergh, Bruce M.		2323 SE 182nd Avenue	Portland	97233	(503) 666-3000
OR	7240	Farmer, Patrick D.		956 Molalla Avenue	Oregon City	97045	(503) 557-7500
OR	7241	Howard, Brian W.		160 NW Main Street	Winston	97496	(541) 637-0515
OR	7242	Farmer, Patrick D.		300 S. Roosevelt, Unit 7, 8, 9	Seaside	97138	(503) 470-4466
OR	7243	Vandenbergh, Bruce M.		2870 B NE Hogan Drive	Gresham	97030	(503) 667-3030
OR	7244	Farmer, Patrick D.		1619 Marine Drive	Astoria	97103	(503) 836-9600
OR	7245	Howard, Brian W.		817 W. Harvard Avenue	Roseburg	97471	(541) 673-2222
OR	7246	Hammer, Timothy R.		635 NE Highway 99 W Space B	McMinnville	97128	(503) 434-4300
OR	7247	Hamilton, Troy C.		16155 NW Cornell Road, Suite 350	Beaverton	97006	(503) 645-0030
OR	7248	Kasuba, Tina K.		2835 19th Avenue, Suite 200	Forest Grove	97116	(503) 992-7722
OR	7249	Poe, Dennis		10117 SE Sunnyside Road, Suite #B	Clackamas	97015	(503) 353-3999
OR	7250	Watson, Jessy R.		2212 Island Avenue, Suite 420	La Grande	97850	(541) 963-2261
OR	7252	Hamilton, Troy C.		1420-A NW 9th Street	Corvallis	97330	(541) 257-5999
OR	7253	Hamilton, Troy C.		29955 S.W. Boones Ferry Road, #G	Wilsonville	97070	(503) 582-9393
OR	7254	Parks, Caleb Jeffrey		2012 Columbia Boulevard	St. Helens	97051	(503) 397-3030
OR	7255	Hammer, Timothy R.		325 SE 1st Avenue	Canby	97013	(503) 266-4944
OR	7256	Hammer, Timothy R.		772 Main Street	Dallas	97338	(503) 623-8888
OR	7258	Hamilton, Troy C.		1080 N. 1st Street	Stayton	97383	(971) 332-1900
OR	7259	Poe, Dennis		1604 S. Highway 97	Redmond	97756	(541) 504-5577
OR	7261	Farmer, Patrick D.		190 Johnson Avenue	Coos Bay	97420	(541) 982-6200
OR	7262	Anderson, Shane H.		10586 Highway 62 #B	Eagle Point	97504	(541) 826-7070
OR	7263	Anderson, Shane H.		2336 Crater Lake Avenue	Medford	97504	(541) 622-8174
OR	7264	Anderson, Shane H.		30 Freeman Court	Central Point	97502	(541) 697-4992
OR	7265	Poe, Dennis		235 SE Yew Lane	Bend	97702	(541) 388-4681
OR	7266	Sellers, Tandy		1211 SW Emigrant	Pendleton	97801	(541) 276-8800
OR	7267	Poe, Dennis		115 E. Highland Avenue, Suite B	Hermiston	97838	(541) 567-4000
OR	7268	Jones, Alaura Heather		16555 NW 12th Street, Suite A	Sherwood	97140	(503) 925-8282
OR	7270	Anderson, Shane H.		407 NE "E" Street	Grants Pass	97526	(541) 472-8601
OR	7271	Vandenbergh, Bruce M.		485 E. Powell Boulevard	Portland	97030	(971) 293-2150
OR	7275	Farmer, Patrick D.		3440 Ocean Boulevard SE	Coos Bay	97420	(541) 269-1000
OR	7278	Poe, Dennis		NE Sunnyside Road & 172nd Avenue	Happy Valley	97808	(503) 344-1000
OR	7280	Farmer, Patrick D.		3691 NW Highway 101	Lincoln City	97367	(541) 364-5003
OR	7288	Christner, Todd W.		225 N. 14th Street	Cottage Grove	97424	(541) 942-1100
OR	7292	Anderson, Shane H.		2967 Washburn Way, Suite A	Klamath Falls	97603	(541) 884-3000

Exhibit B Traditional
as of December 31, 2023

OR	7297	Anderson, Shane H.	51 East Stewart Avenue, Suite 103	Medford	97501	(541) 245-2682
OR	9385	Jones, Alaura Heather	1235 McVey Avenue, Suite C	Lake Oswego	97034	(503) 908-7605
OR	9386	Hamilton, Troy C.	2210 S. Santiam Highway	Lebanon	97355	(541) 248-1755
OR	9387	Farmer, Patrick D.	2775 Highway 101, Suite A	Florence	97439	(541) 901-3030
OR	9389	Ashdown, Jeremy	33444 Havlik Road	Scappoose	97056	(503) 543-1700
OR	9390	Hamilton, Troy C.	15000 SW Barrows Road, Suite 105	Beaverton	97007	(503) 747-7134
OR	9391	McDowell, Andrew Davis	103275A NW 29th Avenue	Portland	97210	(971) 351-3030
OR	9392	Hammer, Timothy R.	5680 Commercial Street SE, Suite #110	Salem	97306	(971) 599-2208
OR	9393	Hammer, Timothy R.	590 Taggart Drive NW, Suite 110	Salem	97304	(971) 273-1234
OR	9394	Farmer, Patrick D.	1546 SE Ensign Lane	Warrenton	97146	(503) 994-0011
OR	9395	Farmer, Patrick D.	34 South Coast Highway	Newport	97365	(541) 264-4044
OR	9396	Parks, Caleb Jeffrey	7066 SW Nyberg Street	Tualatin	97062	(503) 783-8100
OR	9397	Hamilton, Troy C.	703 McClaine Street, Suite G	Silverton	97381	(971) 343-1300
OR	9398	Farmer, Patrick D.	37425 Highway 26	Sandy	97055	(971) 529-0123
PA	3273	Patwary, Saber A.	832 E. Philadelphia Avenue	Boyetown	19512	(610) 367-1775
PA	3275	Khan, Shariq	3300-A Saw Mill Run Boulevard	Brentwood	15227	(412) 881-2961
PA	3277	Khan, Mohammad S.	2233 Baltimore Pike	Oxford	19363	(610) 998-1444
PA	3278	Khan, Mohammad S.	8914-54 Frankford Avenue	Philadelphia	19136	(215) 331-8000
PA	3280	Coskun, Murat	3400 Aramingo Avenue	Philadelphia	19134	(215) 427-3000
PA	3281	Khan, Shariq	320 E. Central Avenue	Titusville	16354	(814) 775-5100
PA	3284	Bhullar, Khushminder S.	900 Business Drive, Suite 101	East Stroudsburg	18302	(570) 223-5050
PA	3286	Coskun, Murat	4229-35 N. Broad Street	Philadelphia	19140	(215) 457-5000
PA	3288	Milne, R. Courtney	104 Carmichaels Plaza	Carmichaels	15320	(724) 966-2430
PA	3289	Kayani, Mohammed K.	890 Butler Street	Pittsburgh	15223	(412) 407-5556
PA	3290	Anis, Furqan	712 Ekastown Road	Sarver	16055	(724) 524-1122
PA	3292	Mikhail, Michael	1611 Manheim Pike	Lancaster	17601	(717) 581-5200
PA	3294	Coskun, Murat	5733 North Broad Street	Philadelphia	19141	(215) 549-2112
PA	3295	Ali, Khurram S.	10900 Perry Highway	Wexford	15090	(724) 799-8686
PA	3355	Baldwin, Adam P.	609 Pennsylvania Avenue E	Warren	16365	(814) 230-9170
PA	4059	Bhullar, Khushminder S.	1235 Pocono Boulevard	Mt. Pocono	18344	(570) 839-0444
PA	4069	Islam, Azharul	1341 Blue Valley Drive	Pen Argyl	18072	(610) 863-8600
PA	4072	Fern, Laura D.	327 N. Market Street	Selinsgrove	17870	(570) 374-5665
PA	4073	Kramer, Melissa S.	906 N. Market Street	Berwick	18603	(570) 759-3100
PA	4074	Ali, Khurram S.	2652 Darlington Road, Unit #80	Beaver Falls	15010	(724) 581-4646
PA	4075	Khan, Mohammad S.	2880 Pottsville Minersville Highway, Suite 110	Minersville	17954	(570) 984-4000
PA	4076	Garcia, David P.	511 N. Pittsburgh Street	Connellsville	15425	(724) 620-0123
PA	4079	Khan, Mohammad S.	171 W. Main Street	Macungie	18062	(610) 966-9800

Exhibit B Traditional
as of December 31, 2023

PA	4080	Bhullar, Khushminder S.		314 Lincoln Avenue	East Stroudsburg	18301	(570) 426-7007
PA	4081	Bhullar, Khushminder S.		231 Claremont Avenue	Tamaqua	18252	(570) 668-4000
PA	4082	Barrick, Todd O.		500 York Street	Gettysburg	17325	(717) 337-9117
PA	4083	Khan, Mohammad S.		991 Baltimore Pike	Glen Mills	19342	(610) 558-9088
PA	4084	Islam, Azharul		1145 N. 5th Street	Perkasie	18944	(215) 453-8440
PA	4085	Gollhardt, Seth R.		1578 Main Street	Peckville	18452	(570) 383-3000
PA	4086	Milne, R. Courtney		903 Nissley Road	Lancaster	17601	(717) 898-9600
PA	4087	Islam, Azharul		620 N. Main Street	Doylestown	18901	(215) 230-0988
PA	4088	Ali, Khurram S.		20455 Route 19	Cranberry Township	16066	(724) 776-6166
PA	4089	Khan, Mohammad S.		1115 S. Bethlehem Pike	Ambler	19002	(215) 654-9000
PA	4090	Port, Sheldon R. Jr.		855 Route 22 West	Blairsville	15717	(724) 675-1233
PA	4091	Port, Sheldon R. Jr.		810 S. Saint Mary Street	Saint Marys	15857	(814) 781-7100
PA	4092	Khan, Mohammad S.		1215 Lancaster Avenue	Rosemont	19010	(610) 527-3434
PA	4093	Jahangir, Waheed		2615 Street Road	Bensalem	19020	(215) 633-9100
PA	4096	Barrick, Todd O.		546 S. Main Street	Shrewsbury	17361	(717) 235-6500
PA	4097	Khan, Muhammad Ratib		1139 Ben Franklin Highway W, Suite 101	Douglasville	19518	(610) 385-0000
PA	4400	Ali, Khurram S.		150 South Broad Street	Grove City	16127	(724) 264-4899
PA	4407	Port, Sheldon R. Jr.		5530 E. Pleasant Valley Boulevard	Tyrone	16686	(814) 682-7424
PA	4409	Port, Sheldon R. Jr.		614 Washington Street	Huntingdon	16652	(814) 644-7444
PA	4412	Bhullar, Khushminder S.		5120 State Route 405	Milton	17847	(570) 742-0100
PA	4415	Ali, Khurram S.		162 Portersville Road	Ellwood City	16117	(724) 752-0752
PA	4416	Kayani, Mohammed K.		24 S. Center Street	Corry	16407	(814) 462-1550
PA	4417	Anis, Furqan		208 19th Street	North Apollo	15673	(724) 596-4574
PA	4418	Anis, Furqan		1001 East Carson Street	Pittsburgh	15203	(412) 432-3232
PA	4427	Khan, Mohammad S.		971 Main Street	Northampton	18067	(610) 261-2400
PA	4428	Rexha, Bashkim		111 E. Broad Street	Souderton	18964	(215) 723-8380
PA	4429	Gollhardt, Seth R.		2834 Memorial Highway, Unit 1	Dallas	18612	(570) 675-2900
PA	4433	Khurram, Raja M.		307 Morgantown Street	Uniontown	15401	(724) 430-3030
PA	4437	Clise, Michael W.		530 North Antrim Way	Greencastle	17225	(717) 597-1099
PA	4439	Khurram, Raja M.		3415 W. Run Road	West Homestead	15120	(412) 205-8787
PA	4447	Coskun, Murat		503 Fox Chase Road	Hollywood	19046	(215) 379-0800
PA	4448	Gregory, James N.		203 Jay Street	Lock Haven	17745	(570) 748-3100
PA	4700	Port, Sheldon R. Jr.		401 Philadelphia Street, Suite 170	Indiana	15701	(724) 349-7310
PA	4701	Khurram, Raja M.		243 West Main Street	Monongahela	15063	(724) 292-4171
PA	4702	Port, Sheldon R. Jr.		1200 Scalp Avenue	Johnstown	15904	(814) 269-2178
PA	4703	Port, Sheldon R. Jr.		3960 Rt.30, Suite 102	Latrobe	15650	(724) 539-3278
PA	4704	Gregory, James N.		100 North Main Street	Du Bois	15801	(814) 371-3300

Exhibit B Traditional
as of December 31, 2023

PA	4708	Malik, Naveed			4631 Center Avenue	Pittsburgh	15213	(412) 681-2024
PA	4709	Khurram, Raja M.			2600 Ardmore Boulevard	Pittsburgh	15221	(412) 824-8700
PA	4710	Malik, Naveed			119 N. Sheridan Avenue	Pittsburgh	15206	(412) 361-4747
PA	4713	Khan, Shariq			6518 Steubenville Pike	Pittsburgh	15205	(412) 505-8187
PA	4714	Port, Sheldon R. Jr.			363 W. Main Street	Somerset	15501	(814) 443-1000
PA	4716	Ali, Khurram S.			42 Seneca Street	Oil City	16301	(814) 670-0391
PA	4717	Port, Sheldon R. Jr.			312 Goucher Street	Johnstown	15905	(814) 535-3030
PA	4720	Khan, Mohammad S.			8537 Allentown Pike, Suite 2&3	Blandon	19510	(610) 569-9000
PA	4721	Khan, Mohammad S.			810 Oley Street, Building 4	Reading	19604	(610) 484-4404
PA	4725	Disman, Robert W.			149 N. Main Street	Slippery Rock	16057	(724) 794-1599
PA	4728	Ali, Khurram S.			3447 Wilmington Road	New Castle	16105	(724) 856-3090
PA	4735	Gregory, James N.			865 Main Street	Clarion	16214	(814) 226-4060
PA	4736	Gollhardt, Seth R.			140 Laurel Plaza	Pittston	18640	(570) 654-4567
PA	4737	Gollhardt, Seth R.			58 S. Mountain Boulevard, Unit 1	Mountain Top	18707	(570) 403-9000
PA	4738	Gollhardt, Seth R.			1121 Northern Boulevard	South Abington Township	18411	(570) 586-4040
PA	4739	Milne, R. Courtney			840 W. Main Street, Unit 6	New Holland	17557	(717) 351-5756
PA	4740	Port, Sheldon R. Jr.			Route 61 Anthra Plaza	Shamokin	17872	(570) 644-2122
PA	4741	Ali, Khurram S.			309 Mars-Valencia Road, Unit B	Mars	16046	(724) 687-7575
PA	4742	Treacy, Edward W. III			614 East Main Street	Waynesboro	17268	(717) 765-0199
PA	4743	Prouse, Donald M. Jr.			1012 Baltimore Street	Hanover	17331	(717) 633-9411
PA	4744	Baldwin, Adam P.			15 Main Street	Bradford	16701	(814) 368-8900
PA	4745	Prouse, Donald M. Jr.			625-D West Elm Avenue	Hanover	17331	(717) 632-9400
PA	4746	Mohtashemi, Paul M.			220 Willow Street	Meadville	16335	(814) 333-4300
PA	4747	Ali, Khurram S.			115 Perry Highway, Suite 170	Harmony	16037	(724) 473-4666
PA	4748	Khan, Mohammad S.			133 West Lincoln Avenue	Myerstown	17067	(717) 970-7000
PA	4749	Khan, Mohammad S.			3801 Perkiomen Avenue	Reading	19606	(610) 370-2343
PA	4750	Khan, Mohammad S.			310 Penn Street	Reading	19602	(610) 376-8501
PA	4751	Khan, Mohammad S.			503 Cumberland Street	Lebanon	17042	(717) 277-7000
PA	4752	Khan, Mohammad S.			300 Terry Reiley Way	Pottsville	17901	(570) 628-4400
PA	4753	Khan, Mohammad S.			2844 Penn Avenue	Reading	19609	(610) 678-7100
PA	4754	Khan, Mohammad S.			799 State Street	Pottstown	19464	(610) 970-2200
PA	4755	Khan, Mohammad S.			253 Schuylkill Road	Phoenixville	19460	(610) 933-3030
PA	4756	Islam, Azharul			859 Nazareth Pike, Bldg. C-1	Nazareth	18064	(610) 746-0600
PA	4757	Khan, Mohammad S.			1405 East Main Street	Annville	17003	(717) 276-6000
PA	4758	Gollhardt, Seth R.			1068 Wyoming Avenue	Wyoming	18644	(570) 694-3030
PA	4759	Ali, Khurram S.			869 E. State Street	Sharon	16146	(724) 347-3020
PA	4760	Khan, Mohammad S.			1350 Pottsville Pike	Shoemakersville	19555	(610) 897-7000

Exhibit B Traditional
as of December 31, 2023

PA	4761	Spalsbury, Curt E.	1100 North Atherton Street, Building #1	State College	16803	(814) 237-1414
PA	4762	Bhullar, Khushminder S.	1311 Washington Boulevard	Williamsport	17701	(570) 322-2022
PA	4763	Spalsbury, Curt E.	607 17th Street	Altoona	16602	(814) 944-6000
PA	4764	Doebler, Donald C. II	1301 Columbia Boulevard, Bloom Plaza, Suite 1	Bloomsburg	17815	(570) 784-6211
PA	4765	Bhullar, Khushminder S.	800-806 N. Church Street	Hazleton	18201	(570) 455-2000
PA	4766	Bhullar, Khushminder S.	7495 Westbranch Highway, Unit #8	Lewisburg	17837	(570) 524-9000
PA	4767	Treacy, Edward W. III	6391 Carlisle Pike, Suite 102	Mechanicsburg	17050	(717) 691-8111
PA	4768	Treacy, Edward W. III	479 Eisenhower Boulevard	Harrisburg	17111	(717) 939-2555
PA	4769	Gregory, James N.	302 1/2 South 2nd Street	Clearfield	16830	(814) 765-6640
PA	4770	Islam, Azharul	503 Baltimore Pike	Springfield	19064	(610) 328-4400
PA	4771	Khan, Mohammad S.	241 E Gay Street	West Chester	19380	(610) 692-0891
PA	4772	Barrick, Todd O.	312 N. Queen Street	Littletown	17340	(717) 345-2777
PA	4773	Barrick, Todd O.	2700 Carlisle Road	Dover	17315	(717) 779-2626
PA	4774	Davis, Daniel A.	3002 N Reading Road	Adamstown	19501	(610) 921-8118
PA	4775	Clise, Michael W.	408 East Queen Street	Chambersburg	17201	(717) 267-3232
PA	4776	Clise, Michael W.	1515 Lincoln Way	Chambersburg	17201	(717) 251-9505
PA	4777	Jahangir, Waheed	508 S. Oxford Valley Road	Fairless Hills	19030	(215) 770-8000
PA	4778	Treacy, Edward W. III	930 S. Richland Avenue, Unit 4	York	17403	(717) 699-2250
PA	4779	Milne, R. Courtney	318 Chestnut Street	Columbia	17512	(717) 684-3006
PA	4780	Milne, R. Courtney	519-B Leaman Avenue	Millersville	17551	(717) 872-9119
PA	4781	Milne, R. Courtney	798-D New Holland Avenue	Lancaster	17602	(717) 295-4500
PA	4782	Khan, Izhar Ali	6518 Route 22, Suite 448	Delmont	15626	(724) 387-9600
PA	4783	Treacy, Edward W. III	351 Loucks Road	York	17404	(717) 854-6650
PA	4784	Port, Sheldon R. Jr.	164 Shikellamy Avenue	Sunbury	17801	(570) 286-5621
PA	4785	Treacy, Edward W. III	1539 Mt. Rose Avenue, Suite A	York	17403	(717) 854-9515
PA	4786	Barrick, Todd O.	401 E. Broadway, Suite 1	Red Lion	17356	(717) 246-3084
PA	4787	Khan, Mohammad S.	695 State Road	Emmaus	18049	(610) 967-4111
PA	4788	Khan, Mohammad S.	330 Larry Holmes Drive	Easton	18042	(610) 258-7100
PA	4789	Islam, Azharul	1353 Easton Avenue	Bethlehem	18018	(610) 865-2700
PA	4790	Khan, Mohammad S.	19 E. Third Street	Bethlehem	18015	(610) 861-0440
PA	4791	Khan, Mohammad S.	2-4 E. Susquehanna Street	Allentown	18103	(610) 709-8644
PA	4792	Khan, Mohammad S.	1826 Union Boulevard	Allentown	18103	(610) 776-2020
PA	4793	Khan, Mohammad S.	3007 N. 5th Street Highway	Reading	19605	(610) 921-8118
PA	4794	Khan, Mohammad S.	155 Mickle Road	Whitehall	18052	(610) 432-7007
PA	4795	Khan, Shariq	21 Foster Avenue	Pittsburgh	15205	(412) 920-4747
PA	4796	Joarder, Mohammed Shamsuzzaman	2308 West Oregon Avenue, Unit #C	Philadelphia	19145	(215) 465-2000
PA	4797	Mikhail, Michael	733 South Broad Street	Lititz	17543	(717) 625-7000

Exhibit B Traditional
as of December 31, 2023

PA	4800	Rexha, Bashkim	804 W. Main Street	Lansdale	19446	(215) 362-8000
PA	4803	Coskun, Murat	157 South 69th Street	Upper Darby	19082	(610) 734-1500
PA	4806	Khan, Mohammad S.	128 W Lancaster Avenue	Wayne	19087	(610) 293-0980
PA	4808	Khan, Mohammad S.	9475 Roosevelt Boulevard	Philadelphia	19114	(215) 346-3030
PA	4809	Khan, Mohammad S.	700 E Chester Pike	Ridley Park	19078	(610) 532-6660
PA	4810	Khan, Mohammad S.	1 Parkside Avenue	Shillington	19607	(610) 910-2000
PA	4811	Khan, Mohammad S.	143 South Gulph Road	King of Prussia	19406	(610) 632-3030
PA	4812	Coskun, Murat	401 North 21st Street	Philadelphia	19130	(215) 557-0940
PA	4813	Coskun, Murat	716 South Street	Philadelphia	19147	(215) 592-8534
PA	4814	Coskun, Murat	150 South MacDade Boulevard	Darby Township	19036	(484) 496-5400
PA	4815	Coskun, Murat	6391 Oxford Avenue B	Philadelphia	19111	(215) 535-1860
PA	4816	Coskun, Murat	5716 - 5746 Baltimore Avenue	Philadelphia	19134	(215) 471-1220
PA	4820	Gollhardt, Seth R.	33 S. Wilkes-Barre Boulevard	Wilkes-Barre	18702	(570) 829-2900
PA	4821	Gollhardt, Seth R.	515 Market Street	Kingston	18704	(570) 283-2900
PA	4823	Khan, Mohammad S.	368 Centre Avenue	Schuylkill Haven	17972	(570) 900-2222
PA	4824	Rexha, Bashkim	1936 W Mcdade Boulevard	Woodlyn	19094	(267) 998-8000
PA	4825	Coskun, Murat	1009 Easton Road	Willow Grove	19090	(215) 657-8090
PA	4826	Islam, Azharul	4233 Edgemont Avenue	Brookhaven	19015	(610) 874-3100
PA	4827	Khan, Mohammad S.	2 N. Park Avenue	Norristown	19403	(610) 631-9090
PA	4828	Khan, Mohammad S.	142 W Germantown Pike #B	E. Norriton	19041	(610) 277-2930
PA	4829	Coskun, Murat	538 Mt. Carmel Avenue	Glenside	19038	(215) 886-1300
PA	4830	Islam, Azharul	3266 Chichester Avenue	Boothwyn	19061	(610) 485-7070
PA	4831	Khan, Mohammad S.	431 West Main Street	Norristown	19401	(610) 906-8600
PA	4833	Khan, Mohammad S.	2601 MacArthur Road	Whitehall	18052	(610) 936-8000
PA	4836	Khan, Shariq	2646 Brodhead Road, Suite 3	Aliquippa	15001	(724) 788-4700
PA	4840	Khan, Mohammad S.	3201 Lincoln Highway	Thorndale	19372	(610) 380-4700
PA	4842	Khan, Mohammad S.	107-109 W. Ridge Pike	Conshohocken	19428	(610) 941-3030
PA	4843	Jahangir, Waheed	833 West Trenton Avenue	Morrisville	19067	(215) 295-3500
PA	4844	Khan, Mohammad S.	43 Cambridge Lane	Newtown	18940	(215) 860-0333
PA	4845	Khan, Mohammad S.	490 Lancaster Avenue, Suite 1	Frazer	19355	(610) 640-4410
PA	4846	Khan, Mohammad S.	3011 William Penn Highway, Unit F	Easton	18045	(610) 915-2000
PA	4847	Khan, Mohammad S.	1 West Penn Avenue	Robesonia	19551	(610) 320-2020
PA	4848	Rexha, Bashkim	803 Horsham Road	Montgomeryville	18936	(215) 362-7660
PA	4852	Mohtashemi, Paul M.	3303 Buffalo Road	Erie	16510	(814) 898-8400
PA	4853	Mohtashemi, Paul M.	5158 Peach Street, Unit #90	Erie	16509	(814) 315-9193
PA	4855	Gollhardt, Seth R.	250 Grandview Avenue, Unit 3	Honesdale	18431	(570) 251-5100
PA	4856	Khan, Shariq	318 Main Street	Greenville	16125	(724) 373-8351

Exhibit B Traditional
as of December 31, 2023

PA	4857	Mohtashemi, Paul M.	7470 West Ridge Road	Fairview	16415	(814) 840-4050
PA	4858	Khan, Mohammad S.	11-C Old Baltimore Pike	Avondale	19311	(610) 268-3211
PA	4860	Khan, Mohammad S.	501 South 29th Street	Harrisburg	17104	(717) 234-4100
PA	4861	Treacy, Edward W. III	1200 Market Street #212	Lemoyne	17043	(717) 763-4100
PA	4862	Treacy, Edward W. III	200 S. Spring Garden Street	Carlisle	17013	(717) 249-1880
PA	4863	Bhullar, Khushminder S.	5285 Devonshire Road	Harrisburg	17109	(717) 657-8181
PA	4864	Treacy, Edward W. III	71 Cumberland Parkway	Mechanicsburg	17055	(717) 766-1618
PA	4866	Khan, Mohammad S.	629 Miller's Hill Road	Kennett Square	19348	(610) 444-6006
PA	4867	Khan, Mohammad S.	2162 E High Street	Pottstown	19464	(610) 340-2000
PA	4868	Khan, Mohammad S.	315 South Cedar Crest Boulevard	Allentown	18103	(610) 894-4000
PA	4870	Gollhardt, Seth R.	1316 N. Main Avenue	Scranton	18508	(570) 347-9200
PA	4871	Gollhardt, Seth R.	1420 Mulberry Street	Scranton	18510	(570) 347-3030
PA	4872	Khan, Mohammad S.	125 North Lewis Road	Royersford	19468	(610) 948-3434
PA	4873	Khan, Mohammad S.	31 S Eagle Road, Suite 103	Havertown	19083	(610) 789-4520
PA	4874	Khan, Mohammad S.	266 East Street Road	Feasterville Trevose	19053	(215) 364-6060
PA	4876	Jahangir, Waheed	2380 Durham Road	Penndel	19047	(215) 547-3333
PA	4877	Khan, Mohammad S.	130 W. Main Street, Suite 118	Trappe	19426	(610) 489-4554
PA	4878	Milne, R. Courtney	2424 Willow Street Pike	Lancaster	17602	(717) 945-5245
PA	4879	Spalsbury, Curt E.	738 Valley Street	Lewistown	17044	(717) 248-5555
PA	4880	Graves, Susan L.	136 W. Franklin Street	Waynesburg	15370	(724) 627-3030
PA	4882	Davis, Daniel A.	108 N. Reading Road, Suite K	Ephrata	17522	(717) 733-5118
PA	4883	Gollhardt, Seth R.	405 S. Main Street	Old Forge	18518	(570) 457-4200
PA	4885	Khan, Mohammad S.	4229 Tilgman Drive	Allentown	18104	(610) 395-1515
PA	4886	Khan, Shariq	1155 Washington Pike, Suite #5	Bridgeville	15017	(412) 998-7100
PA	4888	Khan, Mohammad S.	327 Main Street	Harleysville	19438	(215) 914-9999
PA	4889	Abdou, Ismael Mori	359 E. Market Street	Danville	17821	(570) 275-3131
PA	4890	Barrick, Todd O.	3921 E. Market Street	York	17402	(717) 840-4446
PA	4891	Turjoy, Touquruzzaman	180 Leader Heights Road	York	17402	(717) 741-5115
PA	4892	Patwary, Saber A.	93 S. West End Boulevard, Unit 104	Quakertown	18951	(215) 538-0900
PA	4895	Anis, Furqan	1298 Pittsburgh Street	Cheswick	15024	(724) 715-7176
PA	4897	Khan, Mohammad S.	140 Rainbow Road #38-2P-18	Coatesville	19320	(610) 380-8880
PA	9053	Khan, Muhammad Ratib	622 Gravel Pike, Suite 106	East Greenville	18041	(215) 679-3857
PA	9055	Bhullar, Khushminder S.	2951 PA 611	Tannersville	18372	(570) 629-3040
PA	9056	Khan, Mohammad S.	7720 Main Street, Unit 8A	Fogelsville	18051	(610) 915-2500
PA	9057	Khan, Mohammad S.	575 W. Uwchlan Avenue	Exton	19341	(610) 594-0444
PA	9059	Kayani, Mohammed K.	300 Sixth Avenue, Suite 100	Pittsburgh	15222	(412) 288-8989
PA	9061	Joarder, Mohammed Shamsuzzaman	144 Montgomery Avenue	Bala Cynwyd	19004	(215) 488-5555

Exhibit B Traditional
as of December 31, 2023

PA	9062	Joarder, Mohammed Shamsuzzaman		6001 Lancaster Avenue, Suite A	Philadelphia	19131	(215) 477-6000
PA	9064	Khan, Mohammad S.		2701 North Broad Street	Philadelphia	19132	(215) 225-2272
PA	9065	Khan, Mohammad S.		1909 W. Cheltenham Avenue	Elkins Park	19027	(215) 886-5060
PA	9066	Bhullar, Khushminder S.		1849 Route 405 East	Muncy	17756	(570) 546-1060
PA	9067	Golhardt, Seth R.		2244 San Souci Parkway	Wilkes Barre (Hanover Township)	18706	(570) 735-8700
PA	9068	Gregory, Zonda L.		1138 Allegheny Street	Jersey Shore	17740	(570) 398-7000
PA	9069	Barrick, Todd O.		15 Richwalter Street	Shippensburg	17257	(717) 530-1010
PA	9070	Khurram, Raja M.		232 Countryside Plaza	Mt. Pleasant	15666	(724) 365-6161
PA	9071	Khan, Mohammad S.		293 East Street Road	Warminster	18974	(215) 672-7171
PA	9072	Bhullar, Khushminder S.		620 West Centre Street	Shenandoah	17976	(570) 462-9900
PA	9074	Kayani, Mohammed K.		1019 West View Park Drive	Pittsburgh	15229	(412) 761-1500
PA	9075	Mohtashemi, Paul M.		1101 Peninsula Drive, Suite 214	Erie	16505	(814) 833-5600
PA	9076	Ali, Khurram S.		101 N Jefferson Street	New Castle	16101	(724) 656-2020
PA	9077	Anis, Furqan		5816 Library Road, Suite B	Bethel Park	15102	(412) 854-3030
PA	9078	Anis, Furqan		2885 Leechburg Road	New Kensington	15068	(724) 335-3100
PA	9079	Ali, Khurram S.		109 South Main Street	Butler	16001	(724) 841-0660
PA	9080	Coskun, Murat		4438 Chestnut Street	Philadelphia	19104	(215) 662-1400
PA	9081	Ali, Khurram S.		102 W. Madison Street	Rochester	15074	(724) 770-9090
PA	9082	Khan, Shariq		1300 Brodhead Road, Unit E	Coraopolis	15108	(724) 457-7070
PA	9083	Khan, Izhar Ali		801 N. Greensgate Road, Suite 330	Greensburg	15601	(724) 853-6669
PA	9084	Bhullar, Khushminder S.		540 Westerly Parkway, Suite #19	State College	16801	(814) 237-3030
PA	9085	Ali, Khurram S.		4848 Route 8, Unit 2	Allison Park	15101	(724) 443-0100
PA	9086	Bhullar, Khushminder S.		103 Northside Commons	Palmyra	17078	(717) 838-1000
PA	9087	Kayani, Mohammed K.		11822 Frankstown Road	Penn Hills	15235	(412) 798-0100
PA	9088	Khurram, Raja M.		104 Pricedale Road	Belle Vernon	15012	(724) 929-4444
PA	9089	Bhullar, Khushminder S.		3198 Route 115 North	Effort	18330	(570) 629-3030
PA	9090	Khan, Mohammad S.		15100 Kutztown Road, Suite #4	Kutztown	19530	(610) 894-4444
PA	9092	Port, Sheldon R. Jr.		177 Glimcher Drive	Duncansville	16635	(814) 696-9300
PA	9094	Bhullar, Khushminder S.		182 S Sgt. Stanley Hoffman Boulevard	Lehighton	18235	(610) 377-3030
PA	9095	Khan, Izhar Ali		10729 Route 30	N. Huntingdon	15642	(724) 863-6363
PA	9097	Bhullar, Khushminder S.		2027 Linglestown Road	Harrisburg	17110	(717) 541-1234
PA	9098	Bhullar, Khushminder S.		777 Middletown Road	Hummelstown	17036	(717) 583-2200
PA	9121	Anis, Furqan		400 S. Water Street	Kittanning	16201	(724) 548-5000
PA	9122	Bhullar, Khushminder S.		251 N. Enola Road	Enola	17025	(717) 728-3030
PA	9123	Bhullar, Khushminder S.		20 Main Street	Slatington	18080	(610) 760-1234
PA	9124	Khurram, Raja M.		250 Oak Spring Road	Washington	15301	(724) 225-5050
PA	9125	Khan, Mohammad S.		7325 Castor Avenue	Philadelphia	19152	(215) 722-1330

Exhibit B Traditional
as of December 31, 2023

PA	9126	Turjoy, Touquruzzaman	1575 South Market Street	Elizabethtown	17022	(717) 367-9000
PA	9128	Mohtashemi, Paul M.	1402 Turnpike	Erie	16501	(814) 455-0005
PA	9129	Khan, Mohammad S.	4811 West Chester Pike	Newtown Square	19073	(610) 979-1700
PA	9130	Khan, Izhar Ali	4305 Northern Pike	Monroeville	15146	(412) 858-5100
PA	9131	Coskun, Murat	4600 Roosevelt Boulevard	Philadelphia	19124	(215) 743-2002
PA	9132	Bhullar, Khushminder S.	319 (A) East Chestnut Street	Mifflinburg	17844	(570) 966-3033
PA	9133	Gollhardt, Seth R.	685 Kidder Street	Wilkes-Barre	18702	(570) 829-3030
PA	9134	Joarder, Mohammed Shamsuzzaman	5711 Ridge Avenue	Philadelphia	19128	(215) 712-1000
PA	9135	Port, Sheldon R. Jr.	114 High Street	Bellefonte	16823	(814) 548-7860
PA	9136	Gollhardt, Seth R.	95 Brooklyn Street	Carbondale	18407	(570) 560-6060
PA	9137	Khan, Mohammad S.	3752 PA Route 309, Suite B	Orefield	18069	(610) 601-0101
PA	9138	Khurram, Raja M.	108 South Main Street	Houston	15342	(724) 746-4646
PA	9150	Prouse, Donald M. Jr.	2101 Strickler Road	Manheim	17545	(717) 689-9000
PA	9151	Prouse, Donald M. Jr.	909 Heritage Drive	Elverson	19520	(610) 901-7777
PA	9152	Prouse, Donald M. Jr.	5662 York Road	New Oxford	17350	(717) 353-8888
RI	3901	Christina, William J.	887 N. Main Street	Providence	02904	(401) 861-1200
RI	3902	Zonfrilli, Joseph V.	2145 Pawtucket Avenue	East Providence	02914	(401) 438-6500
RI	3903	Zonfrilli, Joseph V.	1086 Willett Avenue	Riverside	02915	(401) 433-0200
RI	3905	Christina, William J.	1744 Mineral Spring Avenue	North Providence	02911	(401) 654-4100
RI	3906	Rivard, Robert P.	1010 Chalkstone Avenue	Providence	02908	(401) 861-9800
RI	3907	Christina, William J.	526 Broad Street	Providence	02907	(401) 861-4700
RI	3910	Pardy, Michael	557 Warwick Avenue	Warwick	02888	(401) 467-3130
RI	3911	Pardy, Michael	2247 Warwick Avenue	Warwick	02889	(401) 732-2940
RI	3912	Pardy, Michael	2757 Post Road	Warwick	02886	(401) 732-5770
RI	3913	Pardy, Michael	957 Main Street	West Warwick	02893	(401) 826-3636
RI	3914	Lyons, Gregory S.	1745 Main Street	West Warwick	02893	(401) 822-4040
RI	3915	Zonfrilli, Joseph V.	11 Gooding Avenue	Bristol	02809	(401) 254-0404
RI	3920	Zonfrilli, Joseph V.	1401 Park Avenue	Cranston	02920	(401) 946-3300
RI	3921	Zonfrilli, Joseph V.	739 Hartford Avenue	Providence	02919	(401) 331-1123
RI	3924	Botelho, Natasha M.	3383 Mendon Road	Cumberland	02864	(401) 658-0077
RI	3929	Rivard, Robert P.	250 Mendon Road	Cumberland	02864	(401) 725-5050
RI	3930	Zonfrilli, Joseph V.	210 Dexter Street	Pawtucket	02860	(401) 727-1770
RI	3931	Dufficy, Jeffrey P.	448 Newport Avenue	Pawtucket	02861	(401) 727-2000
RI	3935	Rivard, Robert P.	263 Social Street	Woonsocket	02895	(401) 765-3571
RI	3936	Andrade, Sara	140 Point Judith Road #11	Narragansett	02882	(401) 782-1202
RI	3937	Botelho, Natasha M.	900 Victory Highway	North Smithfield	02896	(401) 769-2000
RI	3938	Lyons, Gregory S.	5953 Post Road	North Kingstown	02852	(401) 884-8546

Exhibit B Traditional
as of December 31, 2023

RI	3945	Amaral, Nuno M.	93 Granite Street	Westerly	02891	(401) 596-8850
RI	3950	Zonfrilli, Joseph V.	1397 W. Main Road	Middletown	02842	(401) 849-5520
RI	3951	Zonfrilli, Joseph V.	19 W. Main Road	Middletown	02842	(401) 849-6940
RI	3996	Christina, William J.	9 Cedar Swamp Road, Unit 2	Smithfield	02917	(401) 233-8966
SC	5601	Rinehart, Bridget Fox	5424 Forest Drive, Suite 106	Columbia	29206	(803) 787-1777
SC	5602	Rinehart, Bridget Fox	825 Main Street	Columbia	29210	(803) 256-8151
SC	5603	Rinehart, Bridget Fox	621 Saint Andrews Road	Columbia	29210	(803) 798-6466
SC	5604	Rinehart, Bridget Fox	1180 Dutch Fork Road	Columbia	29063	(803) 691-2000
SC	5605	Rinehart, Bridget Fox	1250 Lake Murray Boulevard	Irmo	29063	(803) 732-1230
SC	5606	Rinehart, Bridget Fox	2406 Augusta Road, Suite H	West Columbia	29169	(803) 791-5309
SC	5607	Rinehart, Bridget Fox	9814 Two Notch Road	Columbia	29223	(803) 736-5344
SC	5608	Rinehart, Bridget Fox	7410 Gamers Ferry Road, Suite B	Columbia	29209	(803) 783-6770
SC	5609	Rinehart, Bridget Fox	6335 N. Main Street	Columbia	29203	(803) 786-5555
SC	5610	Orcutt, Michael L.	11990 Highway 17 Bypass South, Unit 5	Murrells Inlet	29576	(843) 325-2550
SC	5611	Fox, Aaron A.	440 Pamplico Highway	Florence	29505	(843) 292-0499
SC	5612	Rinehart, Bridget Fox	1738 Russell Street	Orangeburg	29115	(803) 531-2883
SC	5615	Fox, Aaron A.	116 Express Lane	Darlington	29532	(843) 395-1410
SC	5616	Orcutt, Michael L.	13088 Ocean Highway	Pawley's Island	29585	(843) 237-3232
SC	5618	Qasim, S. Osman	1750 SC Highway 14	Landrum	29356	(864) 510-0080
SC	5619	Rinehart, Bridget Fox	5443 Platt Springs Road	Lexington	29073	(803) 691-2002
SC	5620	Scheiper, Robert J.	501 Old Greenville Highway, Unit 4	Clemson	29631	(864) 653-7575
SC	5621	Smith, Catherine A.	1006 N. Main Street	Anderson	29621	(864) 226-9393
SC	5622	Scheiper, Robert J.	926 Bypass 123	Seneca	29678	(864) 882-9783
SC	5623	Scheiper, Robert J.	420-A N. Pleasantburg Drive	Greenville	29607	(864) 232-3640
SC	5624	Smith, Catherine A.	605 Williams Avenue	Easley	29640	(864) 855-5051
SC	5626	Scheiper, Robert J.	5600 Augusta Road, Unit D	Greenville	29605	(864) 362-6333
SC	5627	Saeed, Easab	2424 Hudson Road	Greer	29650	(864) 292-5200
SC	5628	Rinehart, Bridget Fox	723 University Village Drive	Blythewood	29016	(803) 764-9700
SC	5629	Rinehart, Bridget Fox	205 Columbia Avenue, Suite A	Lexington	29072	(803) 957-6400
SC	5630	Patterson, G. Mack	1742 Herlong Village Drive, Suite 105	Rock Hill	29732	(803) 329-9900
SC	5631	Patterson, G. Mack	401 Lancaster Bypass E	Lancaster	29720	(803) 285-4313
SC	5632	Patterson, G. Mack	1146 East White Street, Suite B	Rock Hill	29730	(803) 324-3111
SC	5633	Fox, Aaron A.	149 Riverwalk Boulevard, Suites 1-2	Ridgeland	29936	(843) 645-2111
SC	5634	Saeed, Easab	2 Benton Road #A	Traveler's Rest	29690	(864) 610-6355
SC	5635	Patterson, G. Mack	485 Tom Hall Street, Suite 104	Fort Mill	29715	(803) 547-6400
SC	5636	Qasim, S. Osman	2415 Reidville Road	Spartanburg	29301	(864) 576-3030
SC	5637	Qasim, S. Osman	2510 Boiling Springs Road #A	Boiling Springs	29316	(864) 578-9240

Exhibit B Traditional
as of December 31, 2023

SC	5638	Qasim, S. Osman			2199 Southport Road	Spartanburg	29306	(864) 585-3030
SC	5639	Qasim, S. Osman			125 Walton Drive	Gaffney	29341	(864) 489-4072
SC	5640	Kline, Daniel H			217-A Suite 6 Street James Boulevard	Goose Creek	29445	(843) 572-2800
SC	5641	Patterson, G. Mack			1539 Celanese Road, Suite 101	Rock Hill	29732	(803) 325-1900
SC	5642	Kline, Daniel H			1216 N. Main Street, Suite A	Summerville	29483	(843) 875-7300
SC	5643	Orcutt, Michael L.			1300 SC Highway 544, Unit A-3	Conway	29526	(843) 491-9430
SC	5645	Eckburg, John W.			665 Wilson Road	Newberry	29108	(803) 276-4800
SC	5646	Patterson, G. Mack			904 E. Liberty Street	York	29745	(803) 684-0655
SC	5647	Fox, Aaron A.			904-A Highway 301 North	Dillon	29536	(843) 841-2225
SC	5648	Qasim, S. Osman			280 N. Church Street	Spartanburg	29303	(864) 591-3030
SC	5649	Kline, Daniel H			503 North Highway 52, Suite E	Moncks Corner	29461	(843) 761-3300
SC	5650	Kerchenko, Kevin			4965 Centre Pointe Drive	N. Charleston	29418	(843) 747-4400
SC	5651	Kerchenko, Kevin			8530 Dorchester Road, Unit 101	N. Charleston	29420	(843) 552-9494
SC	5652	Scheiper, Robert J.			1286 Eighteen Mile Road	Central	29630	(864) 610-5656
SC	5653	Kerchenko, Kevin			861 Folly Road, Suite 103	James Island	29412	(843) 762-4600
SC	5654	Kline, Daniel H			10645 Dorchester Road, Suite A	Summerville	29485	(843) 875-2191
SC	5655	Smith, Catherine A.			4420 Highway 24	Anderson	29626	(864) 261-3030
SC	5656	Kline, Daniel H			6541 Rivers Avenue, Unit A	N. Charleston	29418	(843) 553-4100
SC	5657	Kline, Daniel H			1930 Ashley River Road, Unit D	Charleston	29407	(843) 571-5200
SC	5658	Kerchenko, Kevin			1039 Highway 17, #5	Mt. Pleasant	29464	(843) 881-7900
SC	5659	Kline, Daniel H			99 Westedge, Suite 1400	Charleston	29403	(843) 720-8600
SC	5660	Orcutt, Michael L.			1706 S. Kings Highway	Myrtle Beach	29577	(843) 626-7666
SC	5661	Orcutt, Michael L.			5335-B N. Kings Highway	Myrtle Beach	29577	(843) 449-2469
SC	5662	Orcutt, Michael L.			810 Highway 17 South	Surfside Beach	29575	(843) 238-8500
SC	5663	Orcutt, Michael L.			1227 16th Avenue, Unit #102	Conway	29526	(843) 248-3646
SC	5664	Fox, Aaron A.			509 Highway 17 N.	North Myrtle Beach	29582	(843) 249-8181
SC	5665	Orcutt, Michael L.			1121 N. Fraser Street	Georgetown	29440	(843) 527-3454
SC	5666	Orcutt, Michael L.			9900-D North Kings Highway	Myrtle Beach	29572	(843) 449-8700
SC	5667	Orcutt, Michael L.			5525 Dick Pond Road	Myrtle Beach	29588	(843) 213-3300
SC	5668	Kerchenko, Kevin			726 North Jefferies Boulevard	Walterboro	29488	(843) 542-9898
SC	5669	Eckburg, John W.			1140 York Street NE	Aiken	29801	(803) 641-0300
SC	5670	Eckburg, John W.			1069 Edgefield Road, Suite 118	North Augusta	29860	(803) 278-3322
SC	5671	Eckburg, John W.			260 East Gate Drive	Aiken	29803	(803) 649-2200
SC	5673	Rinehart, Bridget Fox			3985 Platt Springs Road	West Columbia	29170	(803) 955-3030
SC	5674	Scheiper, Robert J.			3031 White Horse Road	Greenville	29611	(864) 269-0990
SC	5675	Eckburg, John W.			515 A Bypass 72	Greenwood	29649	(864) 223-4444
SC	5676	Griffin, Chad			25050 Highway 76 East	Clinton	29325	(864) 939-8484

Exhibit B Traditional
as of December 31, 2023

SC	5679	Orcutt, Michael L.			2997 E. Highway 501	Conway	29526	(843) 491-9343
SC	5681	Fox, Aaron A.			1108 Highway 170	Beaufort	29902	(843) 524-8200
SC	5682	Fox, Aaron A.			807 William Hilton Parkway, Suite 300	Hilton Head	29928	(843) 681-5111
SC	5683	Rice, Connor James			914 Anderson Street	Piedmont	29673	(864) 610-4500
SC	5684	Eckburg, John W.			2547 Jefferson Davis Highway	Graniteville	29829	(803) 593-0333
SC	5686	Patel, Himanshu B.			11381 Dunbarton Boulevard	Barnwell	29812	(803) 541-8646
SC	5688	Fox, Aaron A.			264 John Street	Lake City	29560	(843) 394-5343
SC	5690	Derham, Allen			102 East Main Street	Pickens	29671	(864) 878-0833
SC	5692	Scheiper, Robert J.			207 N. Hampton Street	Westminster	29693	(864) 647-1800
SC	5693	Scheiper, Robert J.			113 N. Earle Street	Walhalla	29691	(864) 638-9000
SC	5694	Fox, Aaron A.			340 Highway 701 North	Loris	29569	(843) 756-6200
SC	5696	Rinehart, Bridget Fox			190 North Main Street	Gaston	29053	(803) 926-9880
SC	7257	Fox, Aaron A.			22 Plantation Park Drive #206	Bluffton	29910	(843) 706-3111
SC	7273	Patterson, G. Mack			1714 Gold Hill Road	Fort Mill	29708	(803) 547-5300
SC	7276	Derham, Allen			429 East Main Street, Suite N	Liberty	29657	(864) 843-6636
SC	7277	Scheiper, Robert J.			2701-A Woodruff Road	Simpsonville	29681	(864) 234-1500
SC	7279	Saeed, Easab			215/217 W. Wade Hampton Boulevard	Greer	29650	(864) 879-0111
SC	7283	Patterson, G. Mack			125 Evergreen Road	Clover (AKA Lake Wylie)	29710	(803) 366-4667
SC	7284	Kerchenko, Kevin			1117 Parkwest Boulevard	Mt. Pleasant	29466	(843) 216-7104
SC	7286	Qasim, S. Osman			370 Spartanburg Highway	Lyman	29365	(864) 949-3334
SC	7287	Fox, Aaron A.			1230 Rose Street, Suite A	Elgin	29045	(803) 438-3338
SC	7290	Fox, Aaron A.			136 Sea Island Parkway, Suite #3	Beaufort	29907	(843) 522-1000
SC	7291	Rinehart, Bridget Fox			100 Accolades Drive	Columbia	29229	(803) 736-2448
SC	7293	Fox, Aaron A.			819 West Carolina Avenue	Hartsville	29550	(843) 383-3833
SC	7294	Eckburg, John W.			130 Amicks Ferry Road	Chapin	29036	(803) 945-7777
SC	7295	Fox, Aaron A.			494 Pinewood Rd	Sumter	29154	(803) 469-3000
SC	8750	Griffin, Chad			507 North Harper Street, Suite F	Laurens	29360	(864) 715-5575
SC	8751	Eckburg, John W.			4079-C Augusta Highway	Gilbert	29054	(803) 892-2255
SC	8752	Fox, Aaron A.			3377 Highway 9	Little River	29566	(843) 399-6600
SC	8753	Patterson, G. Mack			8447 Charlotte Highway, Suite 700	Fort Mill	29707	(803) 547-9922
SC	8761	Scheiper, Robert J.			113 E. Butler Road, Unit D	Mauldin	29662	(864) 627-9271
SC	8762	Fox, Aaron A.			311 West Mark Rd	Sumter	29150	(803) 469-8000
SC	8763	Fox, Aaron A.			3416 West Palmetto	Florence	29501	(843) 346-1000
SC	8764	Fox, Aaron A.			1335 N. Longstreet	Kingstree	29556	(843) 355-8800
SC	8765	Kerchenko, Kevin			1766 Main Road, Unit B	Johns Island	29455	(843) 203-6887
SC	8766	Kerchenko, Kevin			1400 Palm Boulevard, Suite B	Isle of Palms	29451	(843) 886-4242
SC	8767	Scheiper, Robert J.			616 Poinsett Highway	Greenville	29609	(864) 509-9399

Exhibit B Traditional
as of December 31, 2023

SC	8768	Scheiper, Robert J.	918 South Street	Simpsonville	29681	(864) 962-4100
SC	8769	Fox, Aaron A.	1. W. Rigby Street	Manning	29102	(803) 433-8000
SC	8770	Kerchenko, Kevin	3750 Savannah Highway (Bees Ferry Rd), Unit J	Johns Island	29455	(843) 805-4448
SC	8771	Kline, Daniel H	113 Foxbank Plantation, Suite A	Moncks Corner (Foxbank)	29461	(843) 761-8640
SC	8772	Ridge, John E. Jr.	1220 Bennettsville Square, Hwy 9 West	Bennettsville	29512	(843) 479-0063
SC	8773	Saeed, Easab	2153 E. Main Street, Suite C-13	Duncan-Reidville	29334	(864) 485-2333
SC	8774	Fox, Aaron A.	2406 Broad Street	Camden	29020	(803) 900-5555
SC	8775	Kerchenko, Kevin	162 Seven Farms Drive	Daniel Island	29492	(843) 352-2209
SC	8776	Smith, Catherine A.	6200 Highway 76	Pendleton	29670	(864) 651-2002
SC	8777	Ridge, John E. Jr.	1040 Chesterfield Highway	Cheraw	29520	(843) 865-7077
SD	1800	Graves, Susan L.	1108 S. Minnesota Avenue	Sioux Falls	57105	(605) 331-2121
SD	1801	Graves, Susan L.	4009 E. 10th Street	Sioux Falls	57103	(605) 331-5171
SD	1802	Graves, Susan L.	2401 S. Shirley Avenue	Sioux Falls	57106	(605) 361-2544
SD	1803	Graves, Susan L.	702 N. University Street (aka Ratingen Strasse)	Vermillion	57069	(605) 624-5577
SD	1804	Graves, Susan L.	1207 E. 57th Street	Sioux Falls	57108	(605) 371-3322
SD	1805	Erwin, Allan F.	840 Timmons Boulevard, Suite 8	Rapid City	57703	(605) 503-6106
SD	1814	Deichert, Luke J.	1419 E. Wells	Pierre	57501	(605) 224-6483
SD	1815	Van Diepen, Melissa	25 Market Street E.	Huron	57350	(605) 352-6480
SD	1816	Van Diepen, Melissa	425 North Sanborn	Mitchell	57301	(605) 996-1010
SD	1820	Graves, Susan L.	927 6th Street	Brookings	57006	(605) 697-6688
SD	1821	Graves, Susan L.	1108 S. Broadway Street	Yankton	57078	(605) 689-0999
SD	1825	Graves, Susan L.	912 5th Street SE	Watertown	57201	(605) 882-4242
SD	1826	Duvall, Darin D.	522 S. Main Street	Aberdeen	57701	(605) 225-5555
SD	1840	Erwin, Allan F.	128 E. North Street	Rapid City	57701	(605) 341-2401
SD	1841	Erwin, Allan F.	2604 W. Main Street	Rapid City	57702	(605) 416-9877
SD	1842	Erwin, Allan F.	219 Main Gate Road	Box Elder	57719	(605) 923-1491
SD	1845	Erwin, Allan F.	1410 North Avenue, #7	Spearfish	57783	(605) 642-0288
SD	1846	Erwin, Allan F.	5509 Bendt Drive, Suite #301	Rapid City	57702	(605) 791-5411
SD	1847	Erwin, Allan F.	1057 Main Street	Sturgis	57785	(605) 561-0555
TN	1368	Hamilton, Bryan S.	102 Newport Town Center	Newport	37821	(423) 465-4001
TN	1484	Hamilton, Bryan S.	1146 N. Gateway Avenue	Rockwood	37854	(865) 245-4423
TN	1490	Murph, Alan D.	2609 F Fort Campbell Boulevard	Clarksville	37042	(931) 431-0881
TN	5400	Carrigan, Benjamin Eli	400 E. Lincoln Avenue	Tullahoma	37388	(931) 454-9193
TN	5401	Carrigan, Benjamin Eli	235 Mcts Drive	Murfreesboro	37130	(615) 890-2602
TN	5402	Carrigan, Benjamin Eli	928 W. James Campbell Boulevard	Columbia	38401	(615) 388-8807
TN	5403	Murph, Alan D.	1601 Gallatin Pike North	Madison	37115	(615) 860-3030
TN	5404	Carrigan, Benjamin Eli	400 Downs Boulevard, Suite 100	Franklin	37064	(615) 790-8855

Exhibit B Traditional
as of December 31, 2023

TN	5405	Carrigan, Benjamin Eli	719 Madison Street	Shelbyville	37160	(931) 684-9592
TN	5406	Turner, Ty Michael	429A Walker	Jackson	38305	(731) 668-6644
TN	5407	Doherty, Michael J.	225 E. Gaines Street	Lawrenceburg	38464	(931) 762-9800
TN	5408	Powers, John M.	1415 Hillsboro Boulevard, Suite 102	Manchester	37355	(931) 450-1515
TN	5409	Doherty, Michael J.	603 S 1st Street	Pulaski	38478	(931) 363-6800
TN	5410	Murph, Alan D.	20 Harding Mall Road	Nashville	37211	(615) 333-0300
TN	5411	Murph, Alan D.	5631 Charlotte Pike	Nashville	37209	(615) 352-3030
TN	5412	Carrigan, Benjamin Eli	1144 Fortress Square Boulevard, Suite 1	Murfreesboro	37128	(615) 603-3636
TN	5413	Murph, Alan D.	7087 Old Harding Pike	Nashville	37221	(615) 646-3000
TN	5414	Murph, Alan D.	512 Hadley Village Boulevard	Old Hickory	37138	(615) 650-3030
TN	5415	Murph, Alan D.	3041 Dickerson Pike	Nashville	37207	(615) 228-3030
TN	5416	Murph, Alan D.	5320 Nolensville Road	Nashville	37211	(615) 331-3030
TN	5417	Murph, Alan D.	2535 Lebanon Pike	Nashville	37214	(615) 391-0030
TN	5418	Murph, Alan D.	420 Maple Street	Gallatin	37066	(615) 452-3030
TN	5419	Murph, Alan D.	2610 Gallatin Pike	Nashville	37216	(615) 262-3030
TN	5420	Murph, Alan D.	2109 Abbot Martin Road	Nashville	37215	(615) 383-3030
TN	5421	Murph, Alan D.	823 Hamilton Crossing	Antioch	37013	(615) 360-3030
TN	5422	Murph, Alan D.	2004 Belcourt Avenue	Nashville	37212	(615) 297-3000
TN	5423	Hamilton, Bryan S.	8530 Hixson Pike	Hixson	37343	(423) 843-3030
TN	5424	Turner, Ty Michael	5019 Liberty Street	Milan	38358	(731) 686-9066
TN	5425	Razban, Ahmad	300 University Street	Martin	38237	(731) 587-3167
TN	5426	Carrigan, Benjamin Eli	205 Highway 46	Dickson	37055	(615) 446-7600
TN	5427	Hamilton, Bryan S.	8644 E. Brainard Road	Chattanooga	37421	(423) 899-3030
TN	5428	Carrigan, Benjamin Eli	733 N. Chancery Street	McMinnville	37110	(931) 473-1566
TN	5429	Carrigan, Benjamin Eli	1020 W. Main Street	Lebanon	37087	(615) 449-3733
TN	5430	Powers, John M.	512 N. Willow Avenue	Cookeville	38501	(931) 520-3333
TN	5431	D'Andrea, Peter P.	1952 Oak Ridge Turnpike	Oak Ridge	37830	(865) 482-0022
TN	5432	Carrigan, Benjamin Eli	431 Old Highway 52 Bypass West	Lafayette	37083	(615) 680-0020
TN	5433	Razban, Ahmad	201 Tyson Avenue	Paris	38242	(731) 644-3030
TN	5434	Averill, Kurt	620 E. Reelfoot Avenue	Union City	38261	(731) 885-8866
TN	5437	Dhedhi, Danish W.	1560 Union Avenue	Memphis	38104	(901) 278-3030
TN	5438	Dhedhi, Danish W.	5784 Raleigh Lagrange Road	Memphis	38134	(901) 372-3030
TN	5439	Dhedhi, Danish W.	7539 US Highway 64	Memphis	38133	(901) 383-8282
TN	5440	Murgas, Antonio C.	100 Quinn Lane, Suite A	Clarksville	37042	(931) 552-3030
TN	5441	Murgas, Antonio C.	590 Fire Station Road, Suite A	Clarksville	37043	(931) 552-0030
TN	5442	Dhedhi, Danish W.	7464 Winchester Road	Memphis	38125	(901) 624-5114
TN	5443	Murph, Alan D.	5509 Old Hickory Boulevard, Unit 6	Hermitage	37076	(615) 885-3330

Exhibit B Traditional
as of December 31, 2023

TN	5444	Dhedhi, Danish W.			1327 N Germantown Parkway	Cordova	38108	(901) 754-0303
TN	5445	Dhedhi, Danish W.			7979 US Highway 51 N.	Millington	38053	(901) 873-3030
TN	5446	Murph, Alan D.			356 Main Street	Hendersonville	37075	(615) 264-3030
TN	5447	Murph, Alan D.			300 Pleasant Grove Road, Suite 600	Mt. Juliet	37122	(615) 857-3030
TN	5448	Narlock, Alexander Stephen			3000 Airways Boulevard	Memphis	38116	(901) 344-9999
TN	5449	Powers, John M.			402 W. Main Street	Algood	38506	(931) 650-5555
TN	5450	Dhedhi, Danish W.			550 S Highland Street	Memphis	38111	(901) 323-3030
TN	5451	Murph, Alan D.			2071A Nashville Pike, Suite 100	Gallatin	37066	(615) 709-3030
TN	5452	Powers, John M.			1683 South Jefferson Avenue, Suite A&B	Cookeville	38506	(931) 854-1099
TN	5453	Dhedhi, Danish W.			4235 Summer Avenue	Memphis	38122	(901) 324-3030
TN	5454	Dhedhi, Danish W.			686 Union Avenue	Memphis	38103	(901) 527-3030
TN	5455	Shifflet, Juan Jason			2086 S. Germantown Road	Germantown	38138	(901) 756-6800
TN	5456	Murph, Alan D.			322 Long Hollow Pike, Suite 101	Goodlettsville	37072	(615) 851-0030
TN	5457	Hamilton, Bryan S.			7419 Middlebrook Pike, Suite 101	Knoxville	37909	(865) 693-3939
TN	5458	D'Andrea, Peter P.			4943 Millertown Pike	Knoxville	37917	(865) 507-4747
TN	5459	Hamilton, Bryan S.			11408 Kingston Pike	Farragut	37934	(865) 675-3030
TN	5460	D'Andrea, Peter P.			2469 University Commons Way	Knoxville	37919	(865) 673-3030
TN	5461	D'Andrea, Peter P.			6661 Maynardville Highway	Knoxville	37918	(865) 925-2151
TN	5462	Hamilton, Bryan S.			1211 Taft Highway	Signal Mountain	37377	(423) 886-6177
TN	5464	D'Andrea, Peter P.			412 Merchants Drive	Knoxville	37912	(865) 525-0300
TN	5465	Hamilton, Bryan S.			2636 Highway 411 S.	Maryville	37801	(865) 983-0000
TN	5466	D'Andrea, Peter P.			900 N. Broadway Street	Knoxville	37917	(865) 525-3030
TN	5467	Murph, Alan D.			5407 Main Street, Suite 104	Spring Hill	37174	(931) 487-9090
TN	5468	Hamilton, Bryan S.			9648 Kingston Pike	Knoxville	37922	(865) 560-9000
TN	5469	Hamilton, Bryan S.			7527 Northshore Drive	Knoxville	37919	(865) 690-9500
TN	5470	Hurd, Timothy A.			745 W. Walnut Street	Johnson City	37604	(423) 928-2020
TN	5471	Hurd, Timothy A.			2694 Boones Creek #7	Gray	37604	(423) 283-7777
TN	5472	Hurd, Timothy A.			714 West Center Street	Kingsport	37660	(423) 246-5555
TN	5473	Hurd, Timothy A.			1946 West Elk Avenue	Elizabethton	37643	(423) 542-2211
TN	5474	Hurd, Timothy A.			3077 Fort Henry Drive, Suite 1	Kingsport	37664	(423) 288-7777
TN	5475	Hurd, Timothy A.			3332 West Andrew Johnson Highway	Morristown	37814	(423) 587-1133
TN	5476	Hurd, Timothy A.			179 Millers Landing Boulevard, Suite A	Morristown	37813	(423) 587-5222
TN	5477	Hamilton, Bryan S.			202 N. Main Avenue	Erwin	37650	(423) 388-4100
TN	5478	Turner, Ty Michael			200 Wayne Road	Savannah	38372	(731) 458-6650
TN	5479	Hamilton, Ronald Christopher			1150 Hixson Pike	Chattanooga	37405	(423) 267-3000
TN	5480	Hamilton, Bryan S.			3504 Dayton Boulevard	Red Bank	37415	(423) 870-3030
TN	5481	Hamilton, Ronald Christopher			4155 Ringgold Road	East Ridge	37412	(423) 629-1500

Exhibit B Traditional
as of December 31, 2023

TN	5482	Turner, Ty Michael	3030 Eastend Drive	Humboldt	38343	(731) 784-9229
TN	5483	Carrigan, Benjamin Eli	115 Enon Springs West	Smyrna	37167	(615) 459-0041
TN	5484	Turner, Ty Michael	225 Grace Cove, Suite E	Medina	38355	(731) 251-0030
TN	5485	Hamilton, Ronald Christopher	5730 Highway 58 #C	Harrison	37341	(423) 344-9444
TN	5486	Turner, Ty Michael	17428 Highway 64	Somerville	38068	(901) 716-4686
TN	5487	Hamilton, Bryan S.	2507 N Ocoee Street	Cleveland	37311	(423) 478-3030
TN	5488	Dhedhi, Danish W.	6490 Memphis-Arlington Road, Suite 103	Bartlett	38135	(901) 373-6391
TN	5489	Doherty, Michael J.	409 Main Avenue S	Fayetteville	37334	(931) 433-0500
TN	5490	Hamilton, Bryan S.	1250 Decatur Pike	Athens	37303	(423) 745-7676
TN	5491	Powers, John M.	400 E. Broad Street	Smithville	37166	(615) 597-0001
TN	5492	Carrigan, Benjamin Eli	3987 Memorial Boulevard	Springfield	37172	(615) 384-2100
TN	5493	Carrigan, Benjamin Eli	118 N. Baird Lane	Murfreesboro	37130	(615) 896-0028
TN	5494	Murph, Alan D.	1116 Nashville Highway, Suite 110	Columbia	38401	(931) 269-4022
TN	5495	Murgas, Antonio C.	40 Walton Drive	Waverly	37185	(931) 622-9440
TN	5496	Dhedhi, Danish W.	5780 Airline Road	Arlington	38002	(901) 867-0032
TN	5497	Carrigan, Benjamin Eli	5094 Murfreesboro Road, Suite 1	LaVergne	37086	(615) 213-8900
TN	6113	Brown, Timothy Brett	1706 S. Highland Avenue, Suite B	Jackson	38301	(731) 935-2425
TN	6117	Hamilton, Bryan S.	119 Cooper Street	Etowah	37331	(423) 263-4323
TN	6118	Hamilton, Bryan S.	10750 Hardin Valley Road	Hardin Valley	37932	(865) 364-1777
TN	6129	Turner, Ty Michael	6304 Highway 64	Oakland	38060	(901) 466-1599
TN	6133	Hurd, Timothy A.	111 Justice Center Drive	Rogersville	37857	(423) 272-7009
TN	6134	Carrigan, Benjamin Eli	117 Water Street	Carthage	37030	(615) 709-7070
TN	6136	Coley, Jack	3956 Clarksville Pike	Nashville	37218	(615) 299-8355
TN	6137	Murph, Alan D.	558 East Main Street	Hohenwald	38462	(931) 329-3500
TN	6139	Pitarro, Dominic N.	706 S. Main Street	Sweetwater	37874	(423) 337-2345
TN	6142	Hurd, Timothy A.	720 E. Main Boulevard	Church Hill	37642	(423) 357-2228
TN	6143	Hurd, Timothy A.	1323 Highway 394, Suite D	Blountville	37617	(423) 323-3434
TN	6145	Murph, Alan D.	312 Frey Street	Ashland City	37015	(615) 792-0092
TN	6146	Carrigan, Benjamin Eli	2247 Highway 41 S.	Greenbrier	37073	(615) 643-7666
TN	6147	Turner, Ty Michael	291B South Washington	Ripley	38063	(731) 330-0011
TN	6148	Hamilton, Ronald Christopher	310 Kimball Crossing Drive, Suite 1	Kimball	37347	(423) 837-0777
TN	6149	Turner, Ty Michael	107 Porter Street	Bolivar	38008	(731) 658-6629
TN	6152	Turner, Ty Michael	226 East Court Avenue	Selmer	38375	(731) 645-9907
TN	6153	Pitarro, Dominic N.	4510 Highway 411 North	Madisonville	37354	(423) 442-4555
TN	6154	D'Andrea, Peter P.	623 North Main Street	Lake City	37769	(865) 426-8811
TN	6156	Murgas, Antonio C.	131 Highway 641 N.	Camden	38320	(731) 584-7600
TN	6157	Shoemaker, Justin S.	9325 Apison Pike	Ooltewah	37363	(423) 396-4444

Exhibit B Traditional
as of December 31, 2023

TN	6158	Murph, Alan D.			453 N. Broadway	Portland	37148	(615) 325-2400
TN	6163	Murph, Alan D.			3001 Highway 31 W.	White House	37188	(615) 672-7272
TN	6164	Hurd, Timothy A.			1718 N. Broad Street	New Tazewell	37879	(423) 626-2100
TN	6165	Hamilton, Bryan S.			930 B Mulberry Street	Loudon	37774	(865) 458-0808
TN	6166	Murgas, Antonio C.			2166 Wilma Rudolph Boulevard	Clarksville	37040	(931) 552-3355
TN	6167	Hamilton, Bryan S.			2535 E. Broadway Avenue	Maryville	37804	(865) 983-2525
TN	6168	Turner, Ty Michael			20685 E. Main Street	Huntingdon	38344	(731) 986-8686
TN	6169	Shifflett, Juan Jason			308 New Byhalia Road, Unit 100	Collierville	38017	(901) 853-5030
TN	6171	Carrigan, Benjamin Eli			1051 Murfreesboro Road, Unit 4	Lebanon	37087	(615) 549-0190
TN	6172	Hamilton, Bryan S.			2116 S. Roane Street	Harriman	37748	(865) 882-2424
TN	6173	Hamilton, Ronald Christopher			668 S. College Street	Winchester	37398	(931) 967-4400
TN	6176	Powers, John M.			1539 W. Main Street	Livingston	38570	(931) 823-7777
TN	6177	Razban, Ahmad			15660 Highland Drive	McKenzie	38201	(731) 352-3000
TN	6178	Hamilton, Ronald Christopher			525 E. Race Street	Kingston	37763	(865) 376-1414
TN	6179	McCallen, Mark			2145 Emory Road	Powell	37849	(865) 938-1717
TN	6180	Carrigan, Benjamin Eli			25 E. Mason Court	Woodbury	37190	(629) 444-5559
TN	6181	Turner, Ty Michael			251 W. Main Street	Brownsville	38012	(731) 772-2030
TN	6182	Hamilton, Bryan S.			256 Hamilton Crossing Drive	Alcoa	37701	(865) 328-7222
TN	6183	Dhedhi, Danish W.			1618 Highway 51 S, Unit E	Covington	38019	(901) 475-1980
TN	6184	Hurd, Timothy A.			920 West State Street	Bristol	37620	(423) 764-8080
TN	6185	D'Andrea, Peter P.			409 W. Central Avenue	La Follette	37766	(423) 566-1555
TN	6186	Roberts, Brian T.			10635 Chapman Highway	Seymour	37865	(865) 573-3333
TN	6187	Hurd, Timothy A.			114 East Broadway Boulevard	Jefferson City	37760	(865) 471-6700
TN	6188	Turner, Ty Michael			6 Natchez Trace Drive	Lexington	38351	(731) 968-2030
TN	6189	Anderson, Neal W.			2888 Parkway	Pigeon Forge	37863	(865) 429-1818
TN	6190	Murph, Alan D.			11362 Lebanon Road	Mount Juliet	37122	(615) 754-5175
TN	6191	Solomon, Derek Kevin			45 Genesis Square	Crossville	38555	(931) 456-1414
TN	6192	Hamilton, Bryan S.			131 Kelsey Lane, Suite 103	Lenoir City	37772	(865) 988-7777
TN	6193	Murph, Alan D.			712 N. Ellington Parkway Bldg. A Suite 102	Lewisburg	37091	(931) 359-7000
TN	6194	Hamilton, Bryan S.			1790 Wildwood Avenue	Cleveland	37311	(423) 523-9100
TN	6303	Powers, John M.			486 N. Spring Street	Sparta	38583	(931) 837-9999
TN	6308	Carrigan, Benjamin Eli			1515 Warrior Drive	Murfreesboro	37128	(615) 890-0893
TN	6309	Dhedhi, Danish W.			2821 N. Houston Levee Road, Suite 101	Cordova	38016	(901) 266-0105
TN	6310	Turner, Ty Michael			430 West Main Street	Henderson	38340	(731) 989-9911
TN	6312	D'Andrea, Peter P.			329 Oak Ridge Turnpike, Suite 100	Oak Ridge	37830	(865) 275-0077
TN	6313	Dhedhi, Danish W.			11124 Highway 51 South	Atoka	38004	(901) 837-3663
TN	6318	Murph, Alan D.			3012 Longford Drive, Suite 11	Spring Hill	37174	(615) 302-3040

Exhibit B Traditional
as of December 31, 2023

TN	6319	Hamilton, Ronald Christopher	2629 Topside Road	Louisville	37777	(865) 380-0911
TN	6322	Murph, Alan D.	9040 Carothers Parkway, Suite B107	Franklin	37067	(615) 435-8181
TN	6324	Carrigan, Benjamin Eli	3940 Shelbyville Highway	Murfreesboro	37127	(615) 442-5550
TN	6326	Powers, John M.	7393 SR 28	Dunlap	37327	(423) 949-5656
TN	6329	Murph, Alan D.	4640 Nashville Highway, Suite D	Chapel Hill	37034	(931) 364-5775
TN	8704	D'Andrea, Peter P.	6400/6402 Asheville Highway	Knoxville	37924	(865) 246-0089
TN	8705	Hamilton, Bryan S.	9615 Countryside Center Lane	Knoxville	37931	(865) 694-7711
TN	8708	Turner, Ty Michael	2500 Lake Road, Suite 2	Dyersburg	38024	(731) 285-3030
TN	8709	D'Andrea, Peter P.	4354 Maynardville Highway	Maynardville	37807	(865) 658-0960
TN	8710	D'Andrea, Peter P.	3615 Sutherland Avenue	Knoxville	37919	(865) 246-6330
TN	8711	Anderson, Neal W.	951 E. Parkway	Gatlinburg	37738	(865) 436-2020
TN	8712	Shifflett, Juan Jason	5475 Poplar Avenue	Memphis	38119	(901) 267-5555
TN	8713	Murph, Alan D.	835 4th Avenue South	Nashville	37210	(615) 244-3232
TN	8714	Murgas, Antonio C.	3836-C Trenton Road	Clarksville	37040	(931) 553-1919
TN	8716	D'Andrea, Peter P.	7419 Chapman Highway	Knoxville	37920	(865) 888-0990
TN	8717	Murph, Alan D.	7115 Southpoint Parkway	Brentwood	37027	(615) 331-7277
TN	8718	Murgas, Antonio C.	1206 State Highway 48, Suite C	Clarksville	37040	(931) 542-4220
TN	8719	Anderson, Neal W.	250 Middle Creek, Unit 3	Sevierville	37862	(865) 429-7777
TN	8720	D'Andrea, Peter P.	117 South Main Street	Clinton	37716	(865) 259-7972
TN	8721	Narlock, Alexander Stephen	4230 Elvis Presley Boulevard, Suite 111	Memphis	38116	(901) 217-9999
TN	8722	Murph, Alan D.	1100 Murfreesboro Pike	Nashville	37217	(615) 360-3100
TN	8723	Murph, Alan D.	4904 Thoroughbred Lane B-5	Brentwood	37027	(615) 377-3060
TN	8724	Hamilton, Bryan S.	2335 East Andrew Johnson Highway	Greeneville	37745	(423) 352-9494
TN	8725	Hamilton, Ronald Christopher	3800 Tennessee Avenue, Unit 1	Chattanooga	37409	(423) 821-3030
TN	8726	Turner, Ty Michael	941 North Parkway	Jackson	38305	(731) 410-1911
TX	6320	See, Kevin P.	1061 North Coleman Street, Suite 155	Prosper	75078	(469) 481-6520
TX	6378	Buckner, Rory L.	1807 Slaughter Lane, Suite 465	Austin	78745	(512) 291-8300
TX	6379	Murph, Alan D.	12355 Potranco Road #101	San Antonio	78253	(210) 678-0707
TX	6381	Murph, Alan D.	19750 State Highway 46 W, Suite 101	Spring Branch	78070	(830) 885-3030
TX	6382	Vigil, Lawrence A.	4921 34th Street C	Lubbock	79410	(806) 792-3030
TX	6383	Burnham, Mason	10990 West State Highway 29	Liberty Hill	78642	(512) 778-9010
TX	6384	Pallagi, Christopher J.	7900 N. F M 620, Suite 140	Austin	78726	(512) 258-7000
TX	6386	Hamill, R. Brent	8901 Virginia Parkway, Suite 300	McKinney	75071	(972) 540-9111
TX	6390	See, Kevin P.	1001 S. Highway 377, Suite 101	Aubrey	76227	(940) 440-1257
TX	6395	See, Kevin P.	12000 US Highway 380, Suite #110	Cross Roads	76227	(940) 365-1200
TX	6396	Dain, Katherine Frances	1100 Front Street Alice	Alice	78332	(361) 668-6400
TX	6397	Li, Heng	410 N Highway 175, Suite 203	Seagoville	75159	(972) 287-6200

Exhibit B Traditional
as of December 31, 2023

TX	6404	Cunningham, Michael A.	720 S. Bastrop Highway, Suite 101	Austin	78741	(512) 929-3300
TX	6406	Cunningham, Michael A.	560 Highway 79, Suite A300	Hutto	78634	(512) 759-1799
TX	6407	See, Kevin P.	615 Main Street, Suite #106	Frisco	75036	(972) 292-2228
TX	6408	Mekonnen, Mac A.	2808 S. Main, Suite F	Lindale	75771	(903) 881-9300
TX	6413	Cunningham, Michael A.	201 Hunters Crossing Boulevard	Bastrop	78602	(512) 321-0303
TX	6414	Cunningham, Michael A.	201 N. Main Street	Sweeny	77480	(979) 548-8888
TX	6415	Cunningham, Michael A.	2105 FM 523 Road	Oyster Creek	77541	(979) 239-3333
TX	6416	Valdine, Susan M.	1708 Parkway Drive	Lubbock	79403	(806) 741-8000
TX	6417	Cunningham, Michael A.	1920 Sam Bass Road #100	Round Rock	78681	(512) 246-3639
TX	6418	Murph, Alan D.	105 S Canyonwood Drive	Dripping Springs	78620	(512) 858-1616
TX	6419	Cunningham, Michael A.	7103 FM 1488 Road	Magnolia	77354	(832) 934-2211
TX	6433	Cunningham, Michael A.	18602 FM 1488, Suite 400	Magnolia	77354	(281) 259-6007
TX	6434	Dhedhi, Danish W.	2301A N. Main Street	Liberty	77575	(936) 336-1900
TX	6437	Mekonnen, Mac A.	2906 Gilmer	Longview	75604	(903) 297-9009
TX	6438	Mekonnen, Mac A.	5371 South Broadway	Tyler	75703	(903) 597-8000
TX	6442	Mayhall, Dennis L.	653 N. Saginaw Boulevard	Saginaw	76179	(817) 847-4444
TX	6463	Mekonnen, Mac A.	300 Sharaf Road, Suite #116	Red Oak	75154	(972) 617-1414
TX	6464	Cunningham, Michael A.	18446 Highway 105 West	Montgomery	77356	(936) 582-1114
TX	6466	Murph, Alan D.	2508 N. US Highway 281, Suite 110	Marble Falls	78654	(830) 798-8080
TX	6479	McKanna, Michael Corey	1043 Hickory Creek Boulevard	Hickory Creek	75065	(940) 321-1226
TX	6483	Murph, Alan D.	5353 West US Highway 290, Suite 101	Austin	78735	(512) 599-5555
TX	6484	Murph, Alan D.	1375 S. Main, Suite #213	Boerne	78006	(830) 249-0024
TX	6489	Burnham, Mason	14420 Ronald Reagan Boulevard	Leander	78641	(512) 817-4599
TX	6492	Cunningham, Michael A.	201 W. Brazos Avenue	West Columbia	77486	(979) 345-1600
TX	6493	Salido, Fernando	286 South Bibb	Eagle Pass	78852	(830) 773-9797
TX	6494	Cunningham, Michael A.	23780 Loop 494	Porter	77365	(281) 354-1213
TX	6495	Brown, Randy L. Sr.	7166 Highway 87 N	Orange	77632	(409) 670-9696
TX	6496	Burnham, Mason	651 N. US Highway 183, Suite 190	Leander	78641	(512) 260-7111
TX	6497	Murph, Alan D.	1425 E. Main Street, Suite 400	Fredericksburg	78624	(830) 997-4600
TX	6500	Cunningham, Michael A.	309 E Boling Highway	Wharton	77488	(979) 532-9600
TX	6503	Mayhall, Dennis L.	7101 Colleyville Boulevard Bldg. B	Colleyville	76034	(817) 442-0101
TX	6504	Mekonnen, Mac A.	231 Renaissance Drive	Hallsville	75650	(903) 668-8500
TX	6505	Dennis, Brian K.	11711 Will Clayton Parkway, Suite B	Atascocita	77346	(281) 812-3771
TX	6508	Bailey, Brian K.	1927 Highway 35 N, Suite 1927	Rockport	78382	(361) 729-4700
TX	6516	Bailey, Brian K.	2949 Main Street	Ingleside	78362	(361) 345-1555
TX	6543	Salido, Fernando	12602 Mines Road	Laredo	78045	(956) 948-2672
TX	6549	Bailey, Brian K.	18352 Dallas Parkway, Suite 140	Dallas	75287	(469) 399-0044

Exhibit B Traditional
as of December 31, 2023

TX	6554	Dhedhi, Danish W.		31100 FM 2920 #B	Waller	77484	(936) 372-9800
TX	6557	Pallagi, Christopher J.		900 Ranch Road 620 South, Suite B #101	Lakeway	78734	(512) 402-9444
TX	6558	Renfro, Emily R.		1219 Hwy 16 South	Graham	76450	(940) 549-9994
TX	6559	Mekonnen, Mac A.		404 ST Highway 110 N.	Whitehouse	75791	(903) 871-1215
TX	6561	Cunningham, Michael A.		426 W. Southline Street, Suite F	Cleveland	77327	(281) 659-1000
TX	6563	Cunningham, Michael A.		905 N. Brooks Street	Brazoria	77422	(979) 798-1500
TX	6564	Bailey, Brian K.		4880 Sunnyvale Street	Dallas	75216	(214) 376-6060
TX	6565	Mayhall, Dennis L.		1151 Highway 287	Mansfield	76063	(817) 473-9800
TX	6566	Salido, Fernando		700 N. Main Street (aka Dukas Highway)	La Feria	78559	(956) 797-2121
TX	6567	Mekonnen, Mac A.		2236 N. Center Street	Bonham	75418	(903) 640-1530
TX	6569	Murph, Alan D.		305 South Sidney Baker Street, Suite 200	Kerrville	78028	(830) 257-6700
TX	6570	Mekonnen, Mac A.		1111 George Hopper Road	Midlothian	76065	(972) 775-5551
TX	6571	Marshall, Selby Mark		Taylor Plaza 3210 N. Main	Taylor	76574	(512) 352-7700
TX	6572	Murph, Alan D.		19903 Stone Oak Parkway, Suite 203	San Antonio	78258	(210) 496-1330
TX	6574	Gerety, Cassie		9003 W. University Boulevard	Odessa	79764	(432) 530-3003
TX	6575	Mayhall, Dennis L.		1201 W. Arbrook Boulevard, Suite 125	Arlington	76015	(882) 503-9933
TX	6577	Murph, Alan D.		17331 IH-35 N., Suite #105	Schertz	78154	(210) 651-4336
TX	6578	Mekonnen, Mac A.		511 Highway 79 S.	Henderson	75654	(903) 655-2222
TX	6579	Hamill, R. Brent		3705 Beltline	Sunnyvale	75182	(469) 436-3380
TX	6580	Murph, Alan D.		103 Goliad Road	San Antonio	78223	(210) 533-5933
TX	6581	Mayhall, Dennis L.		636 Boyd Road	Azle	76020	(817) 444-1199
TX	6582	Cunningham, Michael A.		1801 Valley View Drive	College Station	77840	(979) 693-5200
TX	6583	Mekonnen, Mac A.		1600 S. Jefferson Avenue	Mt. Pleasant	75455	(903) 577-3030
TX	6584	Salido, Fernando		3919 Jaime Zapata Memorial Highway	Laredo	78043	(956) 796-0021
TX	6585	Salido, Fernando		409 N. Bryan Road, Suite 101	Mission	78572	(956) 583-8130
TX	6586	Murph, Alan D.		6604 FM 78	San Antonio	78244	(210) 661-4990
TX	6587	Cunningham, Michael A.		14624 FM 2100 (aka Crosby Lynchburg)	Crosby	77532	(281) 328-2244
TX	6590	Salido, Fernando		320 W. Expressway 83, Suite C	Weslaco	78596	(956) 447-4262
TX	6591	Gerety, Cassie		2014 Lamar Street	Sweetwater	79556	(325) 235-4400
TX	6592	Murph, Alan D.		7626 Highway 71, Suite 101	Austin	78735	(512) 288-8886
TX	6593	Salido, Fernando		2407 S Congress Avenue, Suite 100	Austin	78704	(512) 853-9674
TX	6594	Murph, Alan D.		24531 IH-10 W., Suite 108	San Antonio	78257	(210) 698-5506
TX	6601	Salido, Fernando		1900 Guadalupe Avenue	Austin	78705	(512) 477-0101
TX	6602	Salido, Fernando		1906 S. Colorado Street, Suite 103	Lockhart	78644	(512) 398-9090
TX	6603	Salido, Fernando		1931 E. Oltorf Street, Suite F	Austin	78741	(512) 447-6681
TX	6604	Coronis, Stephen Isaac		18220 FM 1431	Jonestown	78645	(512) 584-8161
TX	6605	Marshall, Selby Mark		9616 N. Lamar Boulevard	Austin	78753	(512) 837-7500

Exhibit B Traditional
as of December 31, 2023

TX	6606	Pallagi, Christopher J.	4201B Westbank Drive	Austin	78746	(512) 327-1313
TX	6607	Salido, Fernando	8141 Mesa Drive, #C	Austin	78759	(512) 651-3516
TX	6608	Mekonnen, Mac A.	1111 W. Ledbetter Drive, Suite 450	Dallas	75224	(469) 320-9555
TX	6609	Cunningham, Michael A.	1509 South Lamar, Suite #500	Austin	78704	(512) 447-0404
TX	6610	Sanches, Kristopher John	1200 Barbara Jordan Boulevard, Suite 320B	Austin	78723	(737) 273-1800
TX	6611	Murph, Alan D.	350 N Guadalupe, Suite #150	San Marcos	78666	(512) 392-3030
TX	6613	Salido, Fernando	1700 West Parmer Lane, Suite #640	Austin	78727	(512) 834-1122
TX	6614	Salido, Fernando	719 W. William Cannon Drive #114	Austin	78745	(512) 440-8833
TX	6615	Cunningham, Michael A.	1300 Gattis School Road, Suite 700	Round Rock	78664	(512) 244-3636
TX	6616	Cunningham, Michael A.	13201 Pond Springs Road	Austin	78729	(512) 331-7701
TX	6617	Salido, Fernando	311 W. 5th Street, Suite #101	Austin	78701	(737) 237-4141
TX	6618	Cunningham, Michael A.	2490 E Austin Street, Suites 102 & 103	Giddings	78942	(979) 289-1991
TX	6620	See, Kevin P.	17569 Fishtrap Road, Suite 10	Prosper	75078	(469) 715-6400
TX	6621	Cunningham, Michael A.	15070 Highway 6	Rosharon	77583	(281) 431-2900
TX	6622	Cunningham, Michael A.	2127 E. Highway 190, Suite C	Copperas Cove	76522	(254) 547-7566
TX	6623	Cunningham, Michael A.	1606 S Fort Hood Road	Killeen	76542	(254) 526-7103
TX	6624	Cunningham, Michael A.	1400 Lowes Boulevard	Killeen	76542	(254) 526-4444
TX	6625	Cunningham, Michael A.	5102 E. Veterans Memorial Boulevard	Killeen	76543	(254) 699-4690
TX	6626	Cunningham, Michael A.	4301 S. 31st Street	Temple	76502	(254) 778-6706
TX	6628	Salido, Fernando	2716 W. William Cannon Drive, Suite 200	Austin	78745	(512) 579-0389
TX	6629	Cunningham, Michael A.	2211 E. William Joel Bryan Parkway	Bryan	77802	(979) 774-5567
TX	6630	Cunningham, Michael A.	409 University Drive	College Station	77840	(979) 846-6666
TX	6631	Cunningham, Michael A.	900 Harvey Road, Suite 5B & 6	College Station	77840	(979) 696-6066
TX	6632	Brown, Randy L. Sr.	2411 Avenue I	Huntsville	77340	(936) 291-1451
TX	6633	Cunningham, Michael A.	6557 Fondren	Houston	77036	(713) 270-7722
TX	6634	Cunningham, Michael A.	10766 S. Gessner	Houston	77071	(713) 270-7752
TX	6635	Cunningham, Michael A.	12318 Beechnut Road	Houston	77072	(281) 879-5981
TX	6636	Cunningham, Michael A.	10750 Barker Cypress, Suite 118	Cypress	77433	(281) 373-1133
TX	6637	Cunningham, Michael A.	5733 Kirby Drive	Houston	77005	(713) 523-7770
TX	6638	Cunningham, Michael A.	5204 Bissonnet Street	Bellaire	77401	(713) 667-0668
TX	6639	Cunningham, Michael A.	9117 Stella Link Road	Houston	77025	(713) 668-6241
TX	6640	Dennis, Brian K.	14705 Woodforest Boulevard, Suite 2	Houston	77015	(281) 457-1400
TX	6641	Cunningham, Michael A.	11336 Chimney Rock Road	Houston	77035	(713) 723-4242
TX	6642	Cunningham, Michael A.	15166 Bellaire Boulevard	Houston	77083	(281) 568-5335
TX	6643	Cunningham, Michael A.	11920 Dairy Ashford Road	Sugarland	77478	(281) 242-5600
TX	6644	Dennis, Brian K.	4319 Kingwood Drive	Kingwood	77339	(281) 360-8000
TX	6645	Cunningham, Michael A.	903 N Loop 336 W., Suite A	Conroe	77301	(936) 539-2288

Exhibit B Traditional
as of December 31, 2023

TX	6646	Brown, Randy L. Sr.	12620 Woodforest Boulevard	Houston	77015	(713) 451-3539
TX	6647	Cunningham, Michael A.	25119-D Grogan's Mill Road	The Woodlands	77380	(281) 292-1995
TX	6653	Cunningham, Michael A.	16103 Lexington Boulevard	Sugarland	77479	(281) 980-3797
TX	6656	Miller, Leroy	22001-A Westheimer Parkway	Katy	77450	(281) 646-0290
TX	6658	Dhedhi, Danish W.	14520 Memorial Drive, Suite J	Houston	77079	(281) 497-3977
TX	6660	Brown, Randy L. Sr.	2107 Mac Arthur Drive	W. Orange	77630	(409) 883-5552
TX	6661	Brown, Randy L. Sr.	970 N. Main	Vidor	77662	(409) 769-3299
TX	6662	Cunningham, Michael A.	6755 Phelean Boulevard	Beaumont	77706	(409) 860-3036
TX	6663	Cunningham, Michael A.	100 This Way Street	Lake Jackson	77566	(979) 297-9797
TX	6664	Brown, Randy L. Sr.	2401 Memorial Boulevard	Port Arthur	77640	(409) 983-7771
TX	6665	Cunningham, Michael A.	2435 Texas Parkway #A	Missouri City	77489	(281) 208-0100
TX	6666	Cunningham, Michael A.	301 N. Brazosport Boulevard	Clute	77531	(979) 265-1122
TX	6668	Cunningham, Michael A.	6309 Highway 6	Missouri City	77459	(281) 499-2559
TX	6669	Brown, Randy L. Sr.	4101 Main Street	Groves	77619	(409) 962-0505
TX	6671	Cunningham, Michael A.	1636 FM 2977 Road, Suite 100	Rosenberg	77471	(832) 595-2218
TX	6672	Burnham, Mason	115 South Lakeline Boulevard, Suite 110	Cedar Park	78613	(737) 377-0028
TX	6675	Cunningham, Michael A.	1910 W 18th Street	Houston	77008	(713) 861-0141
TX	6676	Abdelmotal, Elsadig M.	8419 FM359 South, Suite A	Fulshear	77441	(281) 533-4080
TX	6680	Abdelmotal, Elsadig M.	4230 Ella Boulevard	Houston	77018	(713) 956-1994
TX	6681	Abdelmotal, Elsadig M.	7270 Antoine Drive, Suite 300	Houston	77088	(281) 447-1996
TX	6684	Abdelmotal, Elsadig M.	3731 W. Alabama Street	Houston	77027	(713) 621-8744
TX	6693	Cunningham, Michael A.	18502 W Belfort Street	Richmond	77407	(281) 240-6666
TX	6696	Mayhall, Dennis L.	1224 N. Highway 377, Suite #215	Roanoke	76262	(817) 491-8588
TX	6697	Li, Heng	1102 Ranch Road, Suite 216	Forney	75126	(972) 552-1790
TX	6700	Murph, Alan D.	1425 Pleasanton	San Antonio	78221	(210) 924-9200
TX	6701	Murph, Alan D.	129 Bandera Road	San Antonio	78228	(210) 733-3030
TX	6702	Murph, Alan D.	3255 Harry Wurzbach Road	San Antonio	78209	(210) 828-7272
TX	6703	Murph, Alan D.	2921 Pat Booker Road, Suite 128	Universal City	78148	(210) 658-4703
TX	6704	Murph, Alan D.	8442 Fredericksburg Road	San Antonio	78229	(210) 616-0032
TX	6705	Murph, Alan D.	5748 Evers Road	San Antonio	78238	(210) 680-0370
TX	6706	Murph, Alan D.	7315 W. Marbach Drive	San Antonio	78227	(210) 673-6840
TX	6707	Murph, Alan D.	15502 Huebner, Suite 100	San Antonio	78248	(210) 408-5599
TX	6708	Murph, Alan D.	7551 Mccullough Avenue	San Antonio	78216	(210) 822-2021
TX	6709	Murph, Alan D.	6390 DeZavala Road, Suite 107	San Antonio	78249	(210) 696-1600
TX	6710	Murph, Alan D.	12019 Perrin Bietel Road, Suite 100	San Antonio	78223	(210) 657-6042
TX	6711	Murph, Alan D.	3022 Thousand Oaks	San Antonio	78247	(210) 490-9933
TX	6712	Murph, Alan D.	13402 West Avenue, Suite 101	San Antonio	78216	(210) 366-0983

Exhibit B Traditional
as of December 31, 2023

TX	6713	Li, Heng		9550 Helms Trail, Suite 700	Forney	75126	(469) 412-7433
TX	6714	Murph, Alan D.		5498 Walzem Road	San Antonio	78218	(210) 657-2431
TX	6715	Murph, Alan D.		15150 Nacogdoches Road, Suite 195	San Antonio	78247	(210) 646-7070
TX	6716	Murph, Alan D.		9381 Culebra Road	San Antonio	78251	(210) 647-4102
TX	6717	Salido, Fernando		316 Business IH 35 S.	New Braunfels	78130	(830) 629-5662
TX	6718	Murph, Alan D.		751 Best Drive, Suite A	Seguin	78155	(830) 372-3070
TX	6719	Mekonnen, Mac A.		879 US Highway 271 N	Gilmer	75644	(903) 402-1090
TX	6720	McBride, Alfred Timothy		3803 Houston Highway, Suite 800	Victoria	77901	(361) 703-5252
TX	6721	McBride, Alfred Timothy		2007 N. Laurent	Victoria	77901	(361) 576-4154
TX	6723	McBride, Alfred Timothy		320 State Highway 35 S.	Port Lavaca	77979	(361) 552-5678
TX	6724	Molina, Henry		1903 N. Saint Marys Street	Beeville	78102	(361) 358-6871
TX	6725	Buckner, Rory L.		10001 S. IH 35	Austin	78747	(512) 346-5900
TX	6726	Cunningham, Michael A.		788 Fish Creek Thoroughfare	Montgomery	77316	(936) 363-4300
TX	6727	Coronis, Stephen Isaac		302 N Key Street	Lampasas	76550	(512) 265-8855
TX	6728	Dain, Katherine Frances		604 W Avenue J	Robstown	78380	(361) 426-7377
TX	6729	Gerety, Cassie		1106 E. 42nd Street	Odessa	79762	(432) 367-3030
TX	6730	Salido, Fernando		5220 McPherson Road, Suite 102	Laredo	78041	(956) 726-1974
TX	6731	Schweitzer, Michael H.		11810 North Interstate Highway 35, Suite D	Jarrell	76537	(512) 746-2550
TX	6734	Abdelmotal, Elsadig M.		3402 Scott Street	Houston	77004	(713) 225-2828
TX	6735	Montemayor, Oscar		20617 Aldine Westfield	Humble	77338	(281) 443-3030
TX	6737	Abdelmotal, Elsadig M.		8535 C.E. King Parkway	Houston	77044	(281) 459-3030
TX	6738	Montemayor, Oscar		5647 Treaschwig Road	Spring	77373	(281) 645-4443
TX	6739	Mouch, Thomas F.		5405 Avenue I	Rosenburg	77471	(281) 342-7010
TX	6741	Mekonnen, Mac A.		985 W Highway 287 Bypass	Waxahachie	75165	(972) 923-3030
TX	6742	Buckner, Rory L.		101 Hall Professional Drive, Suite D	Kyle	78640	(512) 268-5883
TX	6743	Luttrell, Christopher Scott		311 South FM Road 1187, Suite 300	Aledo	76008	(882) 200-6636
TX	6744	Burnham, Mason		2111 E. Park Street #101	Cedar Park	78613	(512) 651-3512
TX	6745	Brown, Randy L. Sr.		1404 Nederland Avenue	Nederland	77627	(409) 727-7799
TX	6746	Cunningham, Michael A.		1395 College Street	Beaumont	77701	(409) 832-0000
TX	6747	Cunningham, Michael A.		6155 Eastex Freeway	Beaumont	77706	(409) 892-0007
TX	6748	Cunningham, Michael A.		7901 Research Forest Drive, Suite 300	The Woodlands	77382	(281) 298-9444
TX	6749	McKanna, Michael Corey		3380 Long Prairie Road, Suite 100	Flower Mound	75022	(972) 355-2201
TX	6750	Dain, Katherine Frances		2714 S. Staples Street	Corpus Christi	78404	(361) 853-9800
TX	6751	Dain, Katherine Frances		6601 Everhart Road	Corpus Christi	78413	(361) 855-3030
TX	6752	Dain, Katherine Frances		3812 South Staples, Suite B	Corpus Christi	78411	(361) 814-4040
TX	6753	Dain, Katherine Frances		5802 Yorktown Boulevard, Suites A-1 & A-2	Corpus Christi	78414	(361) 929-3993
TX	6754	Dhedhi, Danish W.		825 Austin Street	Hempstead	77445	(979) 710-8181

Exhibit B Traditional
as of December 31, 2023

TX	6755	Dain, Katherine Frances	11217 Leopard Street, Suite 6	Corpus Christi	78410	(361) 241-5326
TX	6756	Dain, Katherine Frances	2222 Airline Road, Suite A-6	Corpus Christi	78414	(361) 993-4070
TX	6757	Dain, Katherine Frances	1500 Wildcat Drive	Portland	78374	(361) 777-0440
TX	6758	Dain, Katherine Frances	2602 Waldron Road #B	Corpus Christi	78418	(361) 937-2684
TX	6759	Dhedhi, Danish W.	3001 Avenue F	Bay City	77414	(979) 244-4775
TX	6760	Dain, Katherine Frances	1620 S. Padre Island Drive	Corpus Christi	78416	(361) 806-2626
TX	6761	Murph, Alan D.	11848 Bandera Road	Helotes	78023	(210) 695-4333
TX	6762	Cunningham, Michael A.	134 N 5th Street	Slisbee	77656	(409) 385-5050
TX	6763	Cunningham, Michael A.	200 W. Fairmont Parkway	La Porte	77571	(281) 470-1167
TX	6764	Cunningham, Michael A.	191C S. LHS Drive	Lumberton	77657	(409) 755-3030
TX	6765	Molina, Henry	609 E. King Avenue	Kingsville	78363	(361) 595-5591
TX	6766	Dennis, Brian K.	3005 Woodland Hills Drive	Kingwood	77339	(281) 358-5300
TX	6767	Salido, Fernando	FM306 & Longhorn Industrial Drive	New Braunfels	78130	(830) 406-6668
TX	6768	Mouch, Thomas F.	1858 FM 359 Road	Richmond	77406	(281) 342-8860
TX	6770	Salido, Fernando	2016 W. Nolana Avenue	McAllen	78504	(956) 630-3067
TX	6771	Salido, Fernando	3355 Boca Chica Boulevard, Suite 2	Brownsville	78521	(956) 554-7200
TX	6772	Salido, Fernando	611 Shiloh Drive, Suite 16	Laredo	78045	(956) 726-3333
TX	6773	Salido, Fernando	943 N. Expressway # 23-24	Brownsville	78520	(956) 541-4040
TX	6775	Cunningham, Michael A.	17220 N Rm 620 Road	Round Rock	78681	(512) 310-5555
TX	6776	Cunningham, Michael A.	2209 Spring Stuebner, Suite 400	Spring	77388	(281) 528-5555
TX	6777	Salido, Fernando	1522 W. University Drive	Edinburg	78539	(956) 380-3030
TX	6778	Salido, Fernando	2050 N. Bedell Avenue	Del Rio	78840	(830) 775-3030
TX	6780	McCormick, The Estate of Mitchel A.	713 N. 77 Sunshine Strip	Harlingen	78550	(956) 428-6296
TX	6781	Abdelmotal, Eisadig M.	9451 Cullen Boulevard #A	Houston	77051	(713) 734-0300
TX	6782	Cunningham, Michael A.	8302 Fairbanks N. Houston	Houston	77064	(713) 466-1500
TX	6783	Cunningham, Michael A.	16001 S. Post Oak Boulevard	Houston	77053	(281) 437-7700
TX	6785	Cunningham, Michael A.	21693 FM 1314, Suite 100	Porter Heights	77406	(281) 354-5300
TX	6786	Cunningham, Michael A.	39014 67th Street	Fort Hood	76544	(254) 532-2332
TX	6787	Abdelmotal, Elsadig M.	5805 Lyons Avenue	Houston	77020	(713) 671-2145
TX	6792	Dhedhi, Danish W.	Building 12740 Memorial Drive, Suite 200	Houston	77024	(713) 464-0708
TX	6793	Dhedhi, Danish W.	1242 E. Mulberry Street	Angleton	77515	(979) 849-6446
TX	6794	Cunningham, Michael A.	1401 S. Gordon Street	Alvin	77511	(281) 585-2222
TX	6795	Murph, Alan D.	2770 E. Evans Road	San Antonio	78259	(210) 499-4422
TX	6796	Mekonnen, Mac A.	201 N. Henderson Boulevard	Kilgore	75662	(903) 983-1530
TX	6797	Murph, Alan D.	921 10th Street, Suite 109	Floresville	78114	(830) 393-7979
TX	6800	Murph, Alan D.	250 W Houston Street	San Antonio	78205	(210) 527-9505
TX	6801	Loehr, Michael Anthony	4114 Burkburnett Road	Wichita Falls	76306	(940) 855-8110

Exhibit B Traditional
as of December 31, 2023

TX	6802	Loehr, Michael Anthony		4518 Maplewood Avenue	Wichita Falls	76308	(940) 691-5818
TX	6803	Dennis, Brian K.		1000 Block E. Loop 304	Crockett	75835	(936) 624-0111
TX	6805	Bailey, Brian K.		1135 E. Irving Boulevard	Irving	75060	(972) 438-7780
TX	6806	Hamill, R. Brent		1717 W. University Drive, Suite 417	McKinney	75069	(972) 548-7070
TX	6808	Cunningham, Michael A.		323 N Main Street	Belton	76513	(254) 939-2888
TX	6809	Abdelmotal, Elsadig M.		9800 Homestead Road	Houston	77016	(713) 633-6330
TX	6810	Cunningham, Michael A.		1006 Fm. 1960 E. Bypass	Humble	77338	(281) 540-3030
TX	6811	Dennis, Brian K.		7036 A-1 FM 1960 Road E.	Humble	77346	(281) 852-3000
TX	6812	Cunningham, Michael A.		901 10th Street	Killeen	76541	(254) 526-9446
TX	6813	Cunningham, Michael A.		305 N. Gulf Boulevard	Freepport	77541	(979) 233-2333
TX	6814	Hamill, R. Brent		1514 Rowlett Road, Suite 101	Garland	75043	(972) 303-0225
TX	6815	Mayhall, Dennis L.		4201 Sw Green Oaks Boulevard	Arlington	76017	(817) 483-9999
TX	6816	Hamill, R. Brent		620 N. Highway 78, Suite 604	Wylie	75098	(972) 442-6101
TX	6817	Palmer, Steven T.		1915 N. FM 1417, Suite 600	Sherman	75092	(903) 813-1212
TX	6818	Mayhall, Dennis L.		7630 N. Beach Street	Ft. Worth	76137	(817) 428-1818
TX	6819	Hamill, R. Brent		5250 State Highway 78, Suite 500	Sachse	75048	(972) 842-4737
TX	6820	Bailey, Brian K.		510 S. Carrter Parkway, Suite 141	Grand Prairie	75051	(972) 642-4600
TX	6821	Mayhall, Dennis L.		7638 McCart Avenue #7640	Ft. Worth	76133	(817) 423-3838
TX	6822	Mekonnen, Mac A.		1107 W. Camp Wisdom Road	Dallas	75232	(214) 375-3030
TX	6823	Bailey, Brian K.		13410 Preston Road, Suite A	Dallas	75240	(972) 386-7200
TX	6824	Bailey, Brian K.		10045 N. MacArthur Boulevard, Suite 109	Irving	75063	(972) 501-9900
TX	6825	Cunningham, Michael A.		11940 S. Highway 6	Sugarland	77478	(832) 351-2600
TX	6826	Cunningham, Michael A.		104 Western Trail, Suite 101	Georgetown	78628	(512) 863-8888
TX	6827	Palmer, Steven T.		3415 W FM 120	Denison	75020	(903) 463-4444
TX	6828	Palmer, Steven T.		1501 N. Grand Avenue, Suite J	Gainesville	76240	(940) 668-8848
TX	6829	Murph, Alan D.		610 Hwy 39, Suite A	Ingram	78025	(830) 867-3030
TX	6830	Murph, Alan D.		2223 W. Avenue N.	San Angelo	76904	(325) 944-0581
TX	6831	Murph, Alan D.		2619 N. Bryant Boulevard	San Angelo	76903	(325) 658-2411
TX	6832	Gerety, Cassie		2624 E. 8th Street	Odessa	79761	(432) 332-3311
TX	6833	Looney, Kenneth Dewayne		1926 Crockett Road	Palestine	75460	(903) 723-2200
TX	6834	Mekonnen, Mac A.		103 East Beltline Road, Suite K	Cedar Hill	75104	(972) 293-2000
TX	6835	Bailey, Brian K.		3725 S. Carrier Parkway, Suite 115	Grand Prairie	75052	(972) 642-6100
TX	6836	Hamill, R. Brent		13004 Spring Oak Drive	Balch Springs	75180	(972) 557-7100
TX	6837	Brown, Randy L. Sr.		2380 Texas Avenue	Bridge City	77611	(409) 735-6886
TX	6838	Mekonnen, Mac A.		1328 S Broadway	Sulphur Springs	75482	(903) 885-1530
TX	6839	Murph, Alan D.		4814 Southland Boulevard	San Angelo	76904	(325) 227-8349
TX	6840	Gerety, Cassie		5001 US Highway 277 S	Abilene	79605	(325) 695-3030

Exhibit B Traditional
as of December 31, 2023

TX	6841	Pallagi, Christopher J.		5145 Ranch Road 620 N, Suite F-125	Austin	78732	(512) 871-0206
TX	6842	Gerety, Cassie		1125 E. N. 10th Street	Abilene	79601	(325) 677-3030
TX	6843	Salido, Fernando		243 W. Main Street	Uvalde	78801	(830) 591-1020
TX	6844	Dhedhi, Danish W.		2650 Highway 36 South	Brenham	77833	(979) 251-9063
TX	6845	Mekonnen, Mac A.		101 South Hampton Road	De Soto	75115	(972) 223-0400
TX	6846	Cunningham, Michael A.		818 E. Louetta Road, Suite 100	Spring	77373	(281) 288-3000
TX	6847	Cunningham, Michael A.		1420 W. Wells Branch Parkway, Suite 105	Plugerville	78660	(512) 251-0996
TX	6848	Mayhall, Dennis L.		807-B Price Road, Suite C	Keller	76248	(817) 431-8888
TX	6849	Mayhall, Dennis L.		6732 Jacksboro Highway	Lake Worth	76135	(817) 237-3600
TX	6850	Dumais, Norma Leticia		8901 Hwy 87 #108	Lubbock	79423	(806) 749-7222
TX	6851	Gerety, Cassie		2111 S. Gregg Street	Big Spring	79721	(432) 267-4111
TX	6852	Murph, Alan D.		9107 Marbach Road	San Antonio	78245	(210) 678-0003
TX	6853	Abdelmotal, Elsadig M.		14057 F.M. 2920	Tomball	77375	(281) 351-0030
TX	6854	Mayhall, Dennis L.		1520 Hewitt Drive	Waco	76712	(254) 666-0222
TX	6855	Gerety, Cassie		604 N. Big Spring Street	Midland	79701	(432) 685-3030
TX	6856	Gerety, Cassie		3111 Faudree Road, Suite E	Odessa	79765	(432) 362-3030
TX	6857	Gerety, Cassie		4519 North Garfield Street	Midland	79705	(432) 689-3030
TX	6858	Gerety, Cassie		3300 W. Illinois Avenue, Suite B	Midland	79703	(432) 699-3030
TX	6859	Gerety, Cassie		2251 Linda Avenue	Odessa	79763	(432) 332-3030
TX	6860	Garner, James W.		7333 Coit Road, Suite 100	Frisco	75035	(469) 362-5755
TX	6861	Vigil, Lawrence A.		5914 Hillside Road	Amarillo	79109	(806) 354-8889
TX	6862	Vigil, Lawrence A.		2604 Wolfllin Avenue	Amarillo	79109	(806) 358-7181
TX	6863	Vigil, Lawrence A.		1701 S. Nelson Street	Amarillo	79103	(806) 376-6111
TX	6864	Howell, Wesley O.		1541 N. Hobart Street	Pampa	79065	(806) 665-8080
TX	6865	Vigil, Lawrence A.		1700 W. 5th Street	Plainview	79072	(806) 291-9999
TX	6866	Vigil, Lawrence A.		301 N 23rd Street, Suite B	Canyon	79015	(806) 655-6600
TX	6870	Vigil, Lawrence A.		2510 Marsha Sharp Freeway, Suite 300	Lubbock	79415	(806) 763-3030
TX	6871	Vigil, Lawrence A.		5407-4th Street, Suite A	Lubbock	79416	(806) 792-3816
TX	6872	Dumais, Michelle A.		2113 50th Street	Lubbock	79412	(806) 762-8484
TX	6873	Vigil, Lawrence A.		5815 82nd Street, Suite 135	Lubbock	79424	(806) 794-5000
TX	6874	Mayhall, Dennis L.		4201 E. Berry Street #18	Fl. Worth	76105	(817) 413-8888
TX	6875	Palmer, Steven T.		2301 Loy Lake Road	Sherman	75090	(903) 868-3838
TX	6876	Hamill, R. Brent		913 W. Stacy Road, Suite 160	Allen	75013	(469) 656-3040
TX	6877	Bailey, Brian K.		4120 W. 15th Street #101	Plano	75093	(469) 543-0420
TX	6879	Garner, James W.		9175 Preston Vineyard	Frisco	75035	(972) 712-4900
TX	6880	Hamill, R. Brent		5076 Doniphon Drive	El Paso	79932	(915) 845-7500
TX	6882	Salido, Fernando		1140 E. Expressway 83	Pharr	78577	(956) 783-3030

Exhibit B Traditional
as of December 31, 2023

TX	6883	Gerety, Cassie			6009 FM 307, Suite 9	Midland	79706	(432) 682-3030
TX	6884	Hamill, R. Brent			3907 Dyer Street	El Paso	79930	(915) 562-3500
TX	6885	Safar, Thomas Burton			3730 E. McKinney, Suite 107A	Denton	76208	(940) 514-1657
TX	6886	Hamill, R. Brent			2128 Wedgewood Drive	El Paso	79925	(915) 594-7555
TX	6887	Hamill, R. Brent			6633 N. Mesa Street, Suite 105	El Paso	79912	(915) 585-9500
TX	6888	Hamill, R. Brent			1895 George Dieter	El Paso	79936	(915) 857-7600
TX	6889	Hamill, R. Brent			10048 Dyer Street	El Paso	79924	(915) 757-3433
TX	6890	Hamill, R. Brent			8613 Alameda Avenue	El Paso	79907	(915) 858-8500
TX	6892	Hamill, R. Brent			6920 Deita Drive, Suite 8	El Paso	77905	(915) 778-4499
TX	6893	Salido, Fernando			795 W. Business Highway 77	San Benito	78586	(956) 276-9696
TX	6894	Mayhall, Dennis L.			3264 Fall Creek Highway	Acton	76049	(817) 326-2466
TX	6895	Busby, Jonathan Michael			409 East Highway 114, Suite 700	Levelland	79336	(806) 894-3030
TX	6896	Luttrell, Christopher Scott			109 S. Ranch House Road, Suite 104	Willow Park	76008	(817) 441-6888
TX	6897	Murph, Alan D.			4547 Rigsby Avenue	San Antonio	78222	(210) 648-9090
TX	6900	Hamill, R. Brent			515 N. Galloway Avenue	Mesquite	75149	(972) 289-7700
TX	6901	Mayhall, Dennis L.			1838 S. Cooper	Arlington	76013	(817) 277-4444
TX	6902	Mayhall, Dennis L.			2801 W. Berry Street	Fort Worth	76109	(817) 921-9393
TX	6903	Mayhall, Dennis L.			1608 Randoll Mill	Arlington	76012	(817) 548-8888
TX	6904	Mayhall, Dennis L.			2501-E Mayfield	Arlington	76014	(817) 465-2000
TX	6905	Mayhall, Dennis L.			5150 River Oaks Boulevard	River Oaks	76114	(817) 625-7676
TX	6906	Mayhall, Dennis L.			2177 W Green Oaks Boulevard	Arlington	76013	(817) 496-0333
TX	6907	Mayhall, Dennis L.			1916 Baird Farm Road	Arlington	76006	(817) 548-8700
TX	6908	Ingram, David			305 East Moore Street	Terrell	75160	(972) 563-0511
TX	6909	Ingram, David			4717-B Wesley St	Greenville	75401	(903) 455-7111
TX	6910	Hamill, R. Brent			8446 Park Lane	Dallas	75231	(214) 691-8284
TX	6911	Bailey, Brian K.			6045 Sherry Lane	Dallas	75225	(214) 691-7511
TX	6912	Mayhall, Dennis L.			3601 N. 19th Street	Waco	76705	(254) 523-6500
TX	6913	Hamill, R. Brent			10704 Garland Road, Suite 100	Dallas	75218	(214) 328-3144
TX	6914	Hamill, R. Brent			149 W. Kingsley Road, Suite 202	Garland	75041	(972) 840-1131
TX	6915	Bailey, Brian K.			1050 N. Westmoreland Road, Suite 110	Dallas	75211	(214) 333-2371
TX	6916	Hamill, R. Brent			3312 N. Buckner Boulevard, Suite 207	Dallas	75228	(214) 324-5394
TX	6917	Hamill, R. Brent			9185 Bruton Road	Dallas	75217	(214) 388-8300
TX	6918	Bailey, Brian K.			10909 Webb Chapel Road, Suite 118	Dallas	75229	(214) 350-4444
TX	6919	Bailey, Brian K.			495 W Illinois	Dallas	75211	(972) 895-3030
TX	6920	Ingram, David			2200 Live Oak	Commerce	75428	(903) 886-2116
TX	6921	Mayhall, Dennis L.			130 E Bardin Road	Arlington	76018	(817) 465-7777
TX	6922	Gerety, Cassie			4700 Briarwood Avenue	Midland	79707	(432) 689-3311

Exhibit B Traditional
as of December 31, 2023

TX	6923	Hamill, R. Brent	1600 N. Plano Road, Suite 2300	Richardson	75081	(972) 231-2200
TX	6924	Bailey, Brian K.	1820 W. Mockingbird Lane, Suite 10	Dallas	75235	(214) 634-7900
TX	6925	Russek II, Ronald L.	615 W. Henderson	Cleburne	76033	(817) 641-6266
TX	6926	Bailey, Brian K.	6505 W. Park Boulevard	Plano	75093	(972) 781-0600
TX	6927	Bailey, Brian K.	13260 Josey Lane, Suite 117	Farmers Branch	75234	(972) 243-1010
TX	6928	Hamill, R. Brent	1332 S. Plano Road, Suite 100	Richardson	75081	(972) 487-1100
TX	6929	Bailey, Brian K.	2419 W. Illinois Avenue	Dallas	75233	(214) 330-4883
TX	6930	Bailey, Brian K.	6451 Riverside Drive	Irving	75039	(972) 474-3030
TX	6931	McKanna, Michael Corey	175 S. Southwest Parkway, Suite 8	Lewisville	75067	(972) 436-3577
TX	6932	Bailey, Brian K.	3829 W. Spring Creek Parkway, Suite #106A	Plano	75023	(972) 618-3030
TX	6933	Bailey, Brian K.	3509 E. Park Boulevard, Suite #170	Plano	75074	(972) 424-4561
TX	6934	Bailey, Brian K.	518 W. Arapahoe Road, Suite 103	Richardson	75080	(972) 235-3600
TX	6935	McKanna, Michael Corey	3733 N. Josey Lane, Suite 116	Carrollton	75007	(972) 492-1116
TX	6936	Bailey, Brian K.	909 W. Spring Creek Parkway, #440	Plano	75023	(972) 517-7000
TX	6937	Safar, Thomas Burton	709 Sunset Street	Denton	76201	(940) 323-2222
TX	6938	Mayhall, Dennis L.	1201 FM 1187 E., Suite 1	Crowley	76036	(817) 297-9922
TX	6939	Mayhall, Dennis L.	4620 Camp Bowie Boulevard	Fort Worth	76107	(817) 738-7777
TX	6940	Mayhall, Dennis L.	4305 W Pipeline Road	Euless	76040	(817) 282-8484
TX	6941	Mayhall, Dennis L.	5400 D Woodway	Ft.Worth	76133	(817) 423-2828
TX	6942	Mayhall, Dennis L.	7218 Grapevine Highway	Richland Hills	76180	(817) 590-8787
TX	6943	Mayhall, Dennis L.	2817 Brown Trail	Bedford	76022	(817) 282-4848
TX	6944	Mayhall, Dennis L.	1101 N. Main	Euless	76039	(817) 355-8855
TX	6945	Mayhall, Dennis L.	3201 Forest Hill Circle	Forest Hill	76140	(817) 551-5656
TX	6946	Mayhall, Dennis L.	600 W Northwest Highway	Grapevine	76051	(817) 310-5855
TX	6947	Mayhall, Dennis L.	6628 Rufe Snow Rd	Ft. Worth	76118	(817) 427-3030
TX	6948	Mayhall, Dennis L.	8808 Highway 580 W (aka Highway 80/Weatherford Highway)	Ft. Worth	76116	(817) 560-3838
TX	6949	Mayhall, Dennis L.	6612-F Brentwood Stair Road	Ft.Worth	76112	(817) 492-4545
TX	6950	Mekonnen, Mac A.	602 Redwater Road	Wake Village	75501	(903) 838-3030
TX	6951	Bailey, Brian K.	3720 Walnut Hill Lane #105	Dallas	75229	(972) 620-7444
TX	6952	Mekonnen, Mac A.	306 E. Ennis Avenue	Ennis	75119	(972) 875-4040
TX	6953	Mayhall, Dennis L.	1151 E. Highway 377, Suite 107	Granbury	76048	(817) 579-1800
TX	6954	Mayhall, Dennis L.	2680 N. Main	Ft. Worth	76164	(817) 624-3535
TX	6955	Mekonnen, Mac A.	300 S. Greer Boulevard	Pittsburg	75686	(903) 855-3035
TX	6956	Mekonnen, Mac A.	506 Loop Highway 59 North	Atlanta	75551	(903) 796-8281
TX	6957	Bailey, Brian K.	1210 E. Main Street #100	Allen	75002	(972) 727-7777
TX	6958	Mekonnen, Mac A.	1828 Lamar Avenue	Paris	75460	(903) 785-5511
TX	6959	Mekonnen, Mac A.	2730 Richmond Road	Texarkana	75503	(903) 832-3030

Exhibit B Traditional
as of December 31, 2023

TX	6960	Mekonnen, Mac A.	110 Triple Creek Drive #45	Longview	75601	(903) 753-8939
TX	6961	Mayhall, Dennis L.	5244 S. State Highway 360	Grand Prairie	75052	(469) 460-6770
TX	6962	Mekonnen, Mac A.	5111 Troup Highway #103	Tyler	75707	(903) 939-3131
TX	6963	Mekonnen, Mac A.	701 W. Gentry Parkway	Tyler	75702	(903) 592-4432
TX	6964	Luttrell, Christopher Scott	801 SE 1st Street	Mineral Wells	76067	(940) 328-1151
TX	6965	Mayhall, Dennis L.	3810 E Beiknap Street	Fort Worth	76111	(817) 831-7575
TX	6966	Luttrell, Christopher Scott	808 Fort Worth Highway, Suite 112	Weatherford	76086	(817) 613-8585
TX	6967	Mayhall, Dennis L.	8723 Highway 377 S.	Benbrook	76126	(817) 249-3333
TX	6968	Bailey, Brian K.	15203 Knoll Trail Drive, Suite 115	Dallas	75248	(972) 387-3030
TX	6969	Mayhall, Dennis L.	711 South Industrial Boulevard	Eules	76040	(817) 785-8787
TX	6970	Looney, Kenneth Dewayne	2403 North Street	Nacogdoches	75965	(936) 569-2121
TX	6971	Bailey, Brian K.	2615 Oaklawn Avenue, Suite 110	Dallas	75219	(214) 520-7100
TX	6972	Tepe, Marcia A.	2100 Victory Drive	Marshall	75672	(903) 935-4383
TX	6973	Bailey, Brian K.	402 E. Wheatland Road	Duncanville	75116	(972) 780-0900
TX	6974	Hamill, R. Brent	4105 Skillman Street	Dallas	75206	(214) 827-8600
TX	6975	Bailey, Brian K.	222 N. Story Road, Suite 118	Irving	75061	(972) 986-1747
TX	6976	Bailey, Brian K.	3305 Walnut Hill Lane	Irving	75038	(972) 255-2257
TX	6977	Hamill, R. Brent	4420 Gaston Avenue	Dallas	75246	(214) 828-9090
TX	6978	McKanna, Michael Corey	1940 FM 407	Highland Village	75067	(972) 317-3030
TX	6979	Safar, Thomas Burton	5000 Main Street, Suite 318	The Colony	75056	(972) 370-8181
TX	6980	Looney, Kenneth Dewayne	1521 S. First Street	Lufkin	75901	(936) 634-5600
TX	6981	Miller, Terry D.	1012 B Coggin Avenue, Suite B	Brownwood	76801	(325) 643-3112
TX	6982	Mayhall, Dennis L.	900 Henderson Street	Fort Worth	76102	(817) 335-8888
TX	6983	Bailey, Brian K.	2220 Marsh Lane, Suite 100	Carrilton	75006	(972) 416-5500
TX	6984	Hamill, R. Brent	10910 North Central Expressway, Suite 600	Dallas	75231	(214) 369-7979
TX	6985	Mayhall, Dennis L.	200 N. 15th Street	Corsicana	75110	(903) 872-8301
TX	6986	Bailey, Brian K.	940 N Riverfront	Dallas	75207	(469) 480-3030
TX	6987	Hamill, R. Brent	1529 W. Buckingham Road #2	Garland	75042	(972) 530-3777
TX	6988	Hamill, R. Brent	2330 Greencrest Boulevard	Rockwall	75087	(972) 771-4092
TX	6989	Mayhall, Dennis L.	700 N Loop 340	Bellmead	76705	(254) 799-3030
TX	6990	Mayhall, Dennis L.	1201 Speight Avenue	Waco	76706	(254) 753-0131
TX	6991	Mayhall, Dennis L.	1428 Wooded Acres Drive, Suite 130	Waco	76710	(254) 776-3442
TX	6992	Mayhall, Dennis L.	9901 China Spring Road, Suite A	Waco	76708	(254) 836-9900
TX	6993	Wolfe, Laura M.	2753 W. Washington	Stephenville	76401	(254) 968-5551
TX	6994	Hamill, R. Brent	2218 Town East Boulevard	Mesquite	75150	(972) 613-5300
TX	6995	Gerety, Cassie	503 E. Interstate 20	Midland	79706	(432) 683-7272
TX	6996	Safar, Thomas Burton	1610 Teasley Lane	Denton	76205	(940) 442-5858

Exhibit B Traditional
as of December 31, 2023

TX	6997	Vigil, Lawrence A.	5985 S. Georgia Street	Amarillo	79118	(806) 641-2414
TX	8001	Buckner, Rory L.	1101 Bunton Creek Road	Kyle	78640	(512) 886-3800
TX	8002	Mayhall, Dennis L.	6600 North Freeway	Fort Worth	76137	(682) 282-4242
TX	8003	Mayhall, Dennis L.	4608 Bryant Irvin Road, Suite 441	Fort Worth	76132	(682) 235-6888
TX	8004	Schweitzer, Michael H.	2208 W. 4th Street	Cameron	76520	(254) 605-0999
TX	8005	Schweitzer, Michael H.	1500 W. Cameron Avenue	Rockdale	76567	(512) 446-2230
TX	8006	Cunningham, Michael A.	5240 N AW Grimes Boulevard	Round Rock	78665	(512) 674-0660
TX	8007	Salido, Fernando	11150 Research Boulevard, Suite 203	Austin	78759	(512) 520-0009
TX	8008	Murph, Alan D.	14249 Potranco Road	San Antonio	78253	(210) 876-3030
TX	8009	Murph, Alan D.	8103 Bandera Road	San Antonio	78250	(210) 960-3030
TX	8010	Murph, Alan D.	1704 Bandera Road	San Antonio	78228	(210) 660-3030
TX	8011	Mekonnen, Mac A.	1050 E. Broadway Avenue	Gladewater	75647	(903) 844-7171
TX	8012	Cunningham, Michael A.	1108 W. Adams Avenue	Temple	76504	(254) 773-3333
TX	8014	Abdelmotal, Elsadig M.	3905 11th Street	Brookshire	77423	(346) 707-2116
TX	8015	Bailey, Brian K.	111 S Cedar Ridge Drive	Duncanville	75116	(469) 283-3030
TX	8016	McBride, Alfred Timothy	1431 East Broadway Avenue	Cuero	77954	(361) 799-4030
TX	8017	See, Kevin P.	695 North Preston Road #110	Celina	75009	(469) 202-3063
TX	8018	Mayhall, Dennis L.	5309 McPherson Boulevard	Fort Worth	76123	(682) 291-9111
TX	8019	Alvarado, Ricardo	2720 John Hayes, Bldg D, Suite 101	El Paso	79938	(915) 248-5500
TX	8020	Benevente, Thomas R.	1551 E. Monte Cristo Road	Edinburg	78542	(956) 305-5500
TX	8021	McKanna, Michael Corey	250 N US Highway 377	Argyle	76226	(940) 784-6333
TX	8022	Mayhall, Dennis L.	815 E. Berry Street, Suite 101	Fort Worth	76110	(682) 291-9199
TX	8023	Hamill, R. Brent	2180 Robert B Cullum Boulevard	Dallas	75210	(972) 707-1666
TX	8024	Cunningham, Michael A.	27605 Robinson Road, Suite 360	Oak Ridge North	77385	(832) 281-8811
TX	8025	Mayhall, Dennis L.	2221 FM 2280	Keene	76059	(817) 645-0088
TX	8027	Bailey, Brian K.	480 W 303 Highway	Grand Prairie	75051	(469) 672-3030
TX	8028	Alvarado, Ricardo	13650 Eastlake Drive, Suite 510	Horizon City	79928	(915) 852-8877
TX	8029	Murph, Alan D.	703 US Highway 90 E, Suite 106	Castroville	78009	(830) 538-3888
TX	8030	Mekonnen, Mac A.	1694 South Beckham Avenue	Tyler	75701	(903) 592-1530
TX	8031	Mayhall, Dennis L.	313 S. Broadway Street, Suite 5	Joshua	76058	(817) 558-3838
TX	8032	Mayhall, Dennis L.	710 North Parkway Drive	Alvarado	76009	(817) 790-6000
TX	8033	Cunningham, Michael A.	3026 E College Park Drive	Conroe	77384	(936) 273-3111
TX	8035	Coronis, Stephen Isaac	7708-B Lohman Ford Road	Lago Vista	78645	(512) 267-3232
TX	8036	Mekonnen, Mac A.	210 Crestway Street, Suite #102	Athens	75751	(903) 670-3160
TX	8037	Murph, Alan D.	1320 W. Oaklawn, Suite A	Pleasanton	78064	(830) 569-5599
TX	8038	Chukwukelu, Christopher E.	723 E. Quinlan Parkway, Suite B	Quinlan	75474	(903) 356-2200
TX	8039	Murph, Alan D.	2819 Palo Alto Road, Suite #101	San Antonio	78211	(210) 924-3030

Exhibit B Traditional
as of December 31, 2023

TX	8040	Salido, Fernando	4570 East US Highway 83, Suite #21	Rio Grande City	78582	(956) 487-8000
TX	8041	Mayhall, Dennis L.	4101 Highway 121	Bedford	76021	(817) 510-0001
TX	8042	Cunningham, Michael A.	13203 Fry Road, Suite 900	Cypress	77433	(281) 758-0626
TX	8043	Alvarado, Ricardo	681 South Horizon Boulevard, Suite K	Socorro	79927	(915) 791-0909
TX	8044	Li, Heng	100 Old Rail Road, Suite C	Kaufman	75142	(469) 376-8001
TX	8045	Cunningham, Michael A.	13731 FM 1097, Suite 200	Willis	77318	(936) 890-9070
TX	8046	Cunningham, Michael A.	23933 Nichols Sawmill Road	Hockley	77447	(281) 259-3363
TX	8047	Bailey, Brian K.	353 S Commercial Street	Aransas Pass	78336	(361) 758-5300
TX	8048	Abdelmotal, Elsadig M.	3607 Old Spanish Trail	Houston	77021	(713) 747-3800
TX	8049	Salido, Fernando	1702 Highway 100, Suite D	Port Isabel	78578	(956) 943-8880
TX	8051	Mouch, Thomas F.	4950 Katy Gaston Road, Suite A	Katy	77494	(281) 574-2070
TX	8052	Salido, Fernando	5460 N. Paredes Line Road, Suite 193	Brownsville	78526	(956) 541-3800
TX	8053	Benevente, Thomas R.	1715 Expressway 83, Suite C-1	Penitas	78576	(956) 584-0404
TX	8054	Marshall, Selby Mark	11211 E. Highway 290, Suite 400	Manor	78653	(512) 272-8888
TX	8055	Avilez, Bernardo	7311 S. Jackson Road, Suite 700	Pharr	78557	(956) 843-8899
TX	8056	Alvarado, Ricardo	12420 Edgemere, Suite 108	El Paso	79938	(915) 855-4555
TX	8057	Mekonnen, Mac A.	1305 N. Bluegrove Road	Lancaster	75134	(972) 227-3015
TX	8058	Mekonnen, Mac A.	930 James Bowie Drive	New Boston	75570	(903) 628-1415
TX	8059	Cunningham, Michael A.	1400 East Old Settlers Boulevard	Round Rock	78664	(512) 428-4809
TX	8060	Mayhall, Dennis L.	717 N. Holland Road, #110	Mansfield	76063	(817) 842-6600
TX	8061	McBride, Alfred Timothy	105 Flint Rock Court	Victoria	77904	(361) 485-0990
TX	8062	Murph, Alan D.	11703 Huebner Road, Suite #105	San Antonio	78230	(210) 236-3888
TX	8063	Murph, Alan D.	3390 William Hardee Road, Building 1387	Fort Sam Houston	78234	(210) 507-5656
TX	8064	Murph, Alan D.	26108 Overlook Parkway, Suite 1119	San Antonio	78260	(210) 253-8100
TX	8065	Murph, Alan D.	9714 Potranco Road	San Antonio	78251	(210) 682-7272
TX	8066	Murph, Alan D.	941 South General McMullen Drive, Suite #102	San Antonio	78237	(210) 278-5500
TX	8067	Abdelmotal, Elsadig M.	12002 Shadow Creek Parkway, Suite 105	Pearland	77584	(713) 436-9990
TX	8068	Harnill, R. Brent	8120 Lakeview Parkway, Suite 500	Rowlett	75088	(469) 304-5900
TX	8069	Murph, Alan D.	6338 Old Pearsall Road, Suite #104	San Antonio	78242	(210) 278-9909
TX	8070	Murph, Alan D.	1803 Vance Jackson #401	San Antonio	78213	(210) 278-9900
TX	8071	Harnill, R. Brent	9661 Audelia Road, Suite 121	Dallas	75238	(214) 340-1100
TX	8072	Murph, Alan D.	6827 N. FM 1604 West	San Antonio (Chase Hill)	78249	(210) 646-6400
TX	8073	Murph, Alan D.	11026 Culebra Road, Suite 103	San Antonio	78253	(210) 651-4040
TX	8074	Murph, Alan D.	1451 Stewart Street, Bldg. 7025	Lackland AFB, San Antonio	78236	(210) 599-6060
TX	8075	Mekonnen, Mac A.	1029 S. Jackson Street	Jacksonville	75766	(903) 339-6606
TX	8076	Cunningham, Michael A.	7410 West Adams Avenue, Suite 100	Temple	76502	(254) 228-5584
TX	8077	Benevente, Thomas R.	306 East Main Avenue, Unit 4	Alton	78573	(956) 581-9300

Exhibit B Traditional
as of December 31, 2023

TX	8078	Hamill, R. Brent			140 E. FM 544, Suite 84	Murphy	75094	(214) 484-2800
TX	8079	Gerety, Cassie			1335 North Main Street	Andrews	79714	(432) 523-2333
TX	8080	Gerety, Cassie			800 South Main Street, Suite 1	Seminole	79360	(432) 758-3334
TX	8081	Buckner, Rory L.			15300 South IH-35, Suite 370	Buda	78610	(512) 312-4334
TX	8124	Mekonnen, Mac A.			4532 US Hwy 259 N, Suite B	Longview	75605	(903) 686-0303
TX	8154	Bailey, Brian K.			5040 Lemmon Avenue	Dallas	75209	(214) 972-3030
TX	8169	McKanna, Michael Corey			2630 N. Josey Lane, Suite 106	Carrollton	75007	(945) 523-0309
TX	8172	See, Kevin P.			2750 Preston Road, Suite 114	Celina	75009	(214) 851-2222
TX	8195	Sanches, Kristopher John			4631 Airport Boulevard, Suite 124	Austin	78751	(512) 374-1000
TX	8196	Vigil, Lawrence A.			43404 Indiana Avenue	Lubbock	79423	(806) 701-5700
TX	8197	Cunningham, Michael A.			20333 S. W. Freeway	Sugar Land	77479	(281) 937-7250
TX	8311	Gerety, Cassie			118 Raul Florez Boulevard	Pecos	79772	(432) 445-0031
TX	8778	Bernal, Michael P			194 South FM 1346	La Vernia	78121	(830) 581-0003
TX	8780	Abdelmotal, Elsadig M.			2210 Highway 71 South	Columbus	78934	(346) 553-2363
TX	8781	Palmer, Steven T.			81750 N Highway 289, Suite 101	Pottsboro	75076	(903) 786-9000
TX	8782	McKanna, Michael Corey			811 International Parkway, Suite 440	Flower Mound	75022	(469) 830-2777
TX	8783	Cunningham, Michael A.			4909 Gattis School Road	Hutto	78634	(512) 846-6666
TX	8784	Luttrell, Christopher Scott			209 W Highway 199, Suite #102	Springtown	76082	(682) 615-3838
TX	8785	Safar, Thomas Burton			2317 W. University Drive #171	Denton	76201	(940) 808-0717
TX	8787	Montemayor, Oscar			1460 County Road 3549	Cleveland	77327	(832) 793-5351
TX	8788	Li, Heng			Hwy 69 & Beasley Boulevard	Whitewright	75491	(903) 364-1888
TX	8789	Mayhall, Dennis L.			8849 N. Tarrant Parkway	North Richland Hills	76182	(682) 334-2500
TX	8790	Dhedhi, Danish W.			4600 7th Street	Bay City	77414	(979) 401-6565
TX	8791	Hamill, R. Brent			4550 El Dorado Parkway	McKinney	75070	(972) 717-0800
TX	8793	Garner, James W.			1303 Preston Road, Suite 300	Frisco	73035	(469) 200-5064
TX	8795	Mouch, Thomas F.			23010 Highland Knolls Drive	Katy	77494	(832) 437-1404
TX	8797	Schweitzer, Michael H.			290 N. Robertson	Salado	76571	(254) 947-1332
TX	8798	Abdelmotal, Elsadig M.			5315 Antoine Drive	Houston	77091	(346) 226-8919
TX	8799	Burnham, Mason			1880 Crystal Falls Parkway	Leander	78645	(737) 757-0045
TX	8828	Li, Heng			562 South Hwy US 69, Suites 100, 200 & 300	Leonard	75452	(903) 587-2888
TX	8831	Brown, Randy L. Sr.			10335 Highway 12, Suite 3	Orange	77632	(409) 745-6662
TX	8862	Bailey, Brian K.			183 Belt Line Road, Suite 150	Irving	75062	(469) 590-3030
TX	9221	Bailey, Brian K.			401 W. Rochelle Road	Irving	75062	(972) 887-3529
TX	9222	Gerety, Cassie			33 Windmill Circle	Abilene	79606	(325) 698-3030
TX	9223	Murph, Alan D.			279 Kearney Boulevard, Bldg 310	Goodfellow AFB	76908	(325) 703-6650
TX	9224	Mekonnen, Mac A.			522 State Highway 31 W	Chandler	75758	(903) 515-4088
TX	9225	Mayhall, Dennis L.			2201 North Tarrant Parkway	Ft. Worth	76177	(817) 529-2828

Exhibit B Traditional
as of December 31, 2023

TX	9226	Li, Heng				100 S.Lake Road, Suite 100	Lavon	75166	(469) 356-1300
TX	9227	Luttrell, Christopher Scott				229 US Highway 380	Bridgeport	76426	(940) 683-3737
TX	9228	Salido, Fernando				3701 Colbath Avenue, Suites 10 & 20	McAllen	78503	(956) 627-2433
TX	9229	Abdelmotal, Elsadig M.				3250 SH 249	Pinehurst	77362	(281) 789-7213
TX	9230	Burnham, Mason				2906 Bagdad Road, Suite 110	Leander	78641	(512) 456-7990
TX	9231	Safar, Thomas Burton				4940 Teasley Lane, Suite 174	Denton	76210	(940) 514-1991
TX	9232	Cunningham, Michael A.				22800 Highway 242	New Caney	77357	(281) 306-3636
TX	9233	Vigil, Lawrence A.				2015 South Coulter Street	Amarillo	79106	(806) 398-3030
TX	9234	Gerety, Cassie				1307B North Loop 250 West, Suite 9	Midland	79706	(432) 694-3331
TX	9235	Bailey, Brian K.				2501 SH 361	Port Aransas	78373	(361) 749-3620
TX	9236	Mekonnen, Mac A.				1963 N Trade Days Boulevard	Canton	75103	(903) 567-3030
TX	9237	Cunningham, Michael A.				850 South Lop 336 W	Conroe	77304	(936) 249-2449
TX	9238	Cunningham, Michael A.				7810-7812 Almeda	Houston	77054	(832) 968-8080
TX	9239	Busby, Jonathan Michael				1402 N. Lubbock Highway, Suite A	Brownfield	79316	(806) 636-3030
TX	9240	Hamill, R. Brent				2601 N. Mesa Street	El Paso	79902	(915) 587-1900
TX	9241	Marshall, Selby Mark				9001 Cameron Road, Suite 203	Austin	78754	(512) 614-0031
TX	9242	Murph, Alan D.				9163 FM 78, Suite 78	Converse	78109	(210) 659-3030
TX	9243	McKanna, Michael Corey				3000 FM 407 E, Suite 200	Bartonville	76226	(940) 455-7500
TX	9244	Brown, Randy L. Sr.				1934 Highway 190 W.	Livingston	77351	(936) 327-4444
TX	9245	Mekonnen, Mac A.				16669 FM 2493	Tyler	75703	(903) 939-0705
TX	9246	Mekonnen, Mac A.				117 E. Main Street	Royce City	75189	(972) 635-2099
TX	9247	Hamill, R. Brent				11400 Sean Haggerty, Building B	El Paso	79934	(915) 626-5464
TX	9248	McKanna, Michael Corey				1500 W Hebron Parkway #110	Carrollton	75010	(972) 395-4700
TX	9249	Dhedhi, Danish W.				101 E Highway 90	Dayton	77535	(936) 258-1900
TX	9250	Mayhall, Dennis L.				12412 Timberland, Suite 332	Ft. Worth	76244	(817) 623-0000
TX	9251	Gerety, Cassie				5107 College Avenue	Snyder	79549	(325) 573-1333
TX	9252	Bailey, Brian K.				3600 Communications Parkway, Suite 635	Plano	75093	(972) 608-2929
TX	9253	Patterson, Jeremy Todd				300 E. 19th Street #300	Dumas	79029	(806) 934-0030
TX	9254	Loehr, Michael Anthony				300 S. Avenue D	Burkburnett	76354	(940) 569-1000
TX	9255	Gerety, Cassie				960 E. 87th Street, Suite A	Odessa	79765	(432) 366-7272
TX	9256	Mayhall, Dennis L.				2484 Avondale-Haslet Road, Suite 600 & 700	Haslet	76052	(817) 529-1111
TX	9257	Mekonnen, Mac A.				711 Estes Drive, Suite 101	Longview	75602	(903) 553-9110
TX	9258	Benevente, Thomas R.				2720 South Expressway 281	Edinburg	78539	(956) 380-5199
TX	9259	Cunningham, Michael A.				2501 E. 7th Street, Suite 300	Austin	78702	(512) 480-0826
TX	9260	Cunningham, Michael A.				6210 Sienna Parkway, Suite 330	Missouri City	77459	(281) 778-0688
TX	9261	Cunningham, Michael A.				1204 Railroad Avenue, Suite 102	Georgetown	78626	(512) 688-5014
TX	9262	Mayhall, Dennis L.				217 N. FM 156, Suite C	Justin	76247	(940) 648-8383

Exhibit B Traditional
as of December 31, 2023

TX	9263	Marshall, Selby Mark	910 Lee Dildy Boulevard, Suite 120	Elgin	78621	(512) 285-4000
TX	9264	Brown, Randy L. Sr.	10424 IH-10, Suite 600	Baytown	77523	(281) 573-3333
TX	9265	Palmer, Steven T.	551 N. Stemmons Freeway	Sanger	76266	(940) 458-1111
TX	9266	Li, Heng	204 E. Princeton Drive	Princeton	75407	(972) 736-1888
TX	9267	Cunningham, Michael A.	18701 Limestone Commercial Drive, Suite 400	Pflugerville	78660	(512) 990-7991
TX	9268	Bernal, Michael P.	119 Business Park Drive, Suite 300	Kenedy	78119	(830) 583-0599
TX	9269	Murph, Alan D.	1290 Wonder World Drive	San Marcos	78666	(512) 392-7272
TX	9270	Murph, Alan D.	11590 Galm Road, Suite 101	San Antonio	78254	(210) 521-3333
TX	9271	Murph, Alan D.	1256 FM 78, Suite 108	Schertz	78154	(210) 659-1515
TX	9272	Sanches, Kristopher John	5317 Nuckols Crossing, Suite 104	Austin	78744	(512) 494-5463
TX	9273	Cunningham, Michael A.	4400 State Highway 6 South	College Station	77845	(979) 431-1424
TX	9274	Cunningham, Michael A.	13764 Research Boulevard, Suite A	Austin	78750	(512) 250-9190
TX	9275	Cunningham, Michael A.	87030 Old Ironsides Avenue, Bldg. 87030	Fort Hood	76544	(254) 532-4444
TX	9276	Cunningham, Michael A.	11511 FM 1960 E.	Huffman	77336	(832) 645-5300
TX	9277	McKanna, Michael Corey	502 South Old Orchard Lane, Suite 104	Lewisville	75067	(972) 436-3570
TX	9278	Salido, Fernando	2013 Wells Branch Parkway, Suite 109	Austin	78728	(512) 992-1375
TX	9279	Palmer, Steven T.	807 S. US 75, Suite 200	Anna	75409	(972) 924-8000
TX	9280	Salido, Fernando	1920 Thurman Street	Laredo	78046	(956) 722-2221
TX	9281	Salido, Fernando	401 E. Business 83	Donna	78537	(956) 461-3030
TX	9282	Abdelmotal, Elsadig M.	2303 State Highway 36, Suite 100	Sealy	77474	(979) 885-0100
TX	9285	Cunningham, Michael A.	3701 Guadalupe Street, Suite 101	Austin	78705	(512) 580-6488
TX	9286	Mayhall, Dennis L.	5650 Rendon Bloodworth Road	Fort Worth	76140	(817) 985-5555
TX	9287	Gerety, Cassie	1208 S. Stockton Avenue	Monahans	79756	(432) 943-3331
TX	9288	Bailey, Brian K.	1133 N. Zang Boulevard, Suite 105	Dallas	75203	(469) 804-6030
TX	9289	Mekonnen, Mac A.	158 Heritage Parkway	Gun Barrel City	75156	(903) 887-4040
TX	9290	Hamill, R. Brent	7500 Stacy Road, Suite 110	McKinney	75070	(214) 592-0344
TX	9291	Bailey, Brian K.	920 S. Belt Line Road, Suite #100	Coppell	75019	(972) 462-1400
TX	9292	Cunningham, Michael A.	3555 Rayford Road, Suite 80	Spring	77386	(281) 528-4083
TX	9294	Palmer, Steven T.	100 Highway 377, Suite 100 & 102	Pilot Point	76258	(940) 686-5500
TX	9295	Burnham, Mason	2051 Cypress Creek Road, Suite R	Cedar Park	78613	(512) 814-2028
TX	9296	Luttrell, Christopher Scott	700 West Hale Avenue	Decatur	76234	(940) 627-4700
TX	9297	Vigil, Lawrence A.	701 North 25 Mile Avenue	Hereford	79045	(806) 360-4200
TX	9298	Renfro, Emily R.	9972 Interstate 20	Eastland	76448	(254) 629-3399
TX	9319	Salido, Fernando	5800 N. 10th Street, Bldg. 100, Suite 140	McAllen	78504	(956) 540-7110
TX	9321	Salido, Fernando	72 E. Grant Street	Roma	78584	(956) 765-2018
TX	9322	Salido, Fernando	1910 West Braker Lane, #500	Austin	78758	(512) 992-0700
TX	9325	Salido, Fernando	512 E. Edinburg Avenue, Suite G	Elsa	78543	(956) 567-2590

Exhibit B Traditional
as of December 31, 2023

TX	9327	Garner, James W.	2930 Preston Road, Suite 170	Frisco	75034	(214) 387-8000
TX	9328	See, Kevin P.	1001 E. Eldorado Parkway, Suite 80	Little Elm	75068	(469) 980-7777
TX	9329	Bailey, Brian K.	1301 Custer Road, Suite 310	Plano	75075	(469) 786-6841
TX	9330	Dhedhi, Danish W.	117 N. Mechanic Street	El Campo	78620	(979) 320-6976
TX	9331	McKanna, Michael Corey	1701 N. Corinth Street	Corinth	76210	(940) 497-3211
TX	9332	Palmer, Steven T.	1020 US Highway 377 N, Suite A	Whitesboro	76273	(903) 564-3444
TX	9333	Schweitzer, Michael H.	14220 W. State Highway 29	Liberty Hill	78642	(512) 778-9300
TX	9334	Cunningham, Michael A.	200 W. Central Texas Expressway, Suite B	Harker Heights	76548	(254) 252-4600
TX	9335	McCormick, Penni Lynn	509 South Expressway 83 C-6	Harlingen	78550	(956) 428-2300
TX	9336	Coronis, Stephen Isaac	203 West Polk Street	Burnet	78611	(512) 234-8551
TX	9337	Salido, Fernando	1606 E. Parmer Lane, Suite #200	Austin	78753	(512) 394-5056
TX	9338	Cunningham, Michael A.	1525 W. Villa Maria Road	Bryan	77807	(979) 823-0010
TX	9339	McKanna, Michael Corey	219 East Church Street	Lewisville	75057	(972) 436-3578
TX	9340	Murph, Alan D.	Bldg 2735	Fort Sam Houston	78234	(210) 510-1555
TX	9341	Gerety, Cassie	1003 North Sycamore	Fort Stockton	79735	(432) 336-9999
TX	9342	Hamill, R. Brent	1605 Antonio Street, Suite B	Anthony	79821	(915) 587-1919
TX	9343	Hamill, R. Brent	20752 Gulf Victory Way	Ft. Bliss	79916	(915) 603-5666
TX	9344	Mayhall, Dennis L.	140 NW John Jones Drive #100	Burleson	76028	(817) 529-5656
TX	9345	Mayhall, Dennis L.	9650 Legacy Drive, Suite 202	Ft. Worth	76108	(817) 632-3888
TX	9347	Cunningham, Michael A.	2001 State Highway 71 West, Suite 10	La Grange	78945	(979) 206-2121
TX	9348	Pallagi, Christopher J.	15500 W. Highway 71, Suite 200	Bee Cave	78738	(512) 712-5733
TX	9349	Vigil, Lawrence A.	4525 Milwaukee Avenue, Unit 400	Lubbock	79407	(806) 701-4570
TX	9352	Palmer, Steven T.	228 West Main Street	Denison	75020	(903) 463-2222
TX	9360	Palmer, Steven T.	Henry Hynds Expressway & Texana Street	Van Alstyne	75495	(903) 712-2121
TX	9361	Pallagi, Christopher J.	11805 Bee Cave Road, Suite #200	Bee Caves	78738	(512) 551-9916
TX	9362	Dain, Katherine Frances	3719 Leopard Street	Corpus Christi	78408	(361) 400-4050
TX	9363	Dain, Katherine Frances	523 W. Sinton Street	Sinton	78387	(361) 587-6400
TX	9364	Dain, Katherine Frances	15401 S. Padre Island Drive	Corpus Christ	78418	(361) 589-5800
TX	9365	Murph, Alan D.	5701 W. Slaughter Lane Bldg A, Suite 160	Austin	78749	(737) 212-9005
TX	9366	Dain, Katherine Frances	5656 Weber Road	Corpus Christi	78413	(361) 851-4040
TX	9371	Mayhall, Dennis L.	7207 South Cooper Street, Suite 131	Arlington	76001	(882) 816-0808
TX	9372	Sanchez, Kristopher John	6929 Airport Boulevard, Suite 100	Austin	78752	(512) 599-4444
TX	9373	Murph, Alan D.	2022 Goliad Road	San Antonio	78223	(210) 229-7272
TX	9374	Salido, Fernando	4010 N Conway Avenue, Suite D&E	Mission	78573	(956) 997-5858
TX	9375	Mayhall, Dennis L.	8465 Boat Club Road, Suite 101	Fort Worth	76179	(817) 391-8338
TX	9377	Murph, Alan D.	2209 S Bridge Street	Brady	76825	(925) 597-1613
TX	9379	McKanna, Michael Corey	420 E Round Grove Road	Lewisville	75067	(469) 830-7999

Exhibit B Traditional
as of December 31, 2023

TX	9381	Mayhall, Dennis L.	606 South Robinson Drive, Suite A	Robinson	76706	(254) 492-8400
TX	9382	Bernal, Michael P	166 Menefee Street, Suite A	Hondo	78861	(830) 444-0600
TX	9383	Murph, Alan D.	4470 Green Valley	Cibola	78108	(830) 971-3030
TX	9384	Murph, Alan D.	2211 State Highway 46 S, Suite 103	New Braunfels,	78130	(830) 783-3030
TX	9411	Benevente, Thomas R.	7205 W 7 Mile N Road	Mission	78574	(956) 997-6800
TX	9412	Dumais, Norma Leticia	604 N. Dallas Avenue	Lamesa	79331	(806) 332-7200
TX	9414	Palmer, Steven T.	1109 E. McCart Street	Krum	76249	(940) 482-1000
TX	9415	Gerety, Cassie	934 N Mockingbird Lane	Abilene	79603	(325) 673-1333
TX	9416	Cunningham, Michael A.	3244 Meridiana Parkway	Rosharon	77583	(281) 595-9595
TX	9417	See, Kevin P.	2552 Eldorado Parkway	Frisco	75033	(972) 292-9739
TX	9418	McKanna, Michael Corey	2816 SH 121	Lewisville	75056	(469) 922-3577
TX	9420	Murph, Alan D.	1216 Junction Highway	Kerrville	78028	(830) 496-3444
TX	9421	Montemayor, Oscar	806 E. Airtex, Suite 103	Houston	77073	(281) 645-4145
TX	9422	Abdelmotal, Elsadig M.	1416 W. Orem Drive, Suite A	Houston	77047	(346) 502-2058
TX	9423	Bailey, Brian K.	17509 Coit Road	Dallas	75252	(469) 405-3030
TX	9434	Vigil, Lawrence A.	7611 82nd Street	Lubbock	79424	(806) 224-1914
TX	9435	Quirey, Jonalan M	1818 Water Street	Gonzales	78629	(830) 203-6990
TX	9437	Bailey, Brian K.	521 North TX-214, Suite 100	Denver City	79323	(806) 305-0110
TX	9440	Palmer, Steven T.	3260 S US Highway 75	Sherman	75083	(903) 209-2829
TX	9441	Clair, Chelsey Elizabeth	302 E. Broad Street, Suite B	Mineola	75773	(903) 638-2100
UT	7500	Kearns, David	210 E. 100 S.	Roosevelt	84066	(435) 722-2024
UT	7501	Riddle, Charles M.	156 W Cougar Boulevard	Provo	84604	(801) 418-1100
UT	7502	Riddle, Charles M.	120 N State Street	Orem	84057	(801) 226-2100
UT	7503	Riddle, Charles M.	3370 N University Avenue	Provo	84604	(885) 309-3601
UT	7504	Riddle, Charles M.	2058 W 1700 S, Suite 107	Syracuse	84075	(801) 776-1440
UT	7505	Rompel, Micheal SC	8944 S 700 E	Sandy	84070	(801) 255-3538
UT	7506	Rompel, Micheal SC	721 E 2100 S	Salt Lake City	84106	(801) 486-6991
UT	7507	Riddle, Charles M.	702 S 700 E	Salt Lake City	84102	(801) 350-3807
UT	7508	Riddle, Charles M.	1735 E Skyline Drive, Suite 1	Ogden	84405	(801) 479-3600
UT	7509	Rompel, Micheal SC	2282 S Redwood Road	West Valley City	84119	(801) 972-0097
UT	7510	Rompel, Micheal SC	1781 W 5400 S	Taylorville	84129	(801) 966-0407
UT	7511	Rompel, Micheal SC	4086 W 5415 S	Salt Lake City	84118	(801) 964-2928
UT	7512	Riddle, Charles M.	189 US-89, Suite F	North Salt Lake	84054	(801) 349-2838
UT	7513	Riddle, Charles M.	1156 W 600 N	Salt Lake City	84116	(801) 595-0347
UT	7514	Rompel, Micheal SC	6064 S State Street	Salt Lake City	84107	(801) 261-1769
UT	7515	Rompel, Micheal SC	2911 East 3300 South	Salt Lake City	84109	(801) 889-1515
UT	7516	Rompel, Micheal SC	153 E 4370 S	Murray	84107	(801) 265-2685

Exhibit B Traditional
as of December 31, 2023

UT	7517	Rompel, Micheal SC	1067 W South Jordan Parkway	South Jordan	84095	(801) 253-8789
UT	7518	Rompel, Micheal SC	4756 S Highland Drive	Salt Lake City	84117	(801) 272-9134
UT	7519	Rompel, Micheal SC	2129 E 9400 S	Sandy	84093	(801) 942-7499
UT	7520	Riddle, Charles M.	1596 N Hill Field Road	Layton	84041	(801) 728-9188
UT	7521	Beadles, Jonathon G.	775 S. Main Street	Smithfield	84335	(435) 213-3549
UT	7522	Riddle, Charles M.	2060 Harrison Boulevard	Ogden	84401	(801) 399-9999
UT	7523	Riddle, Charles M.	1430 S Foothill Drive	Salt Lake City	84108	(801) 582-5424
UT	7524	Rompel, Micheal SC	11419 S 700 E	Draper	84020	(801) 572-3560
UT	7525	Avelar, Israel V.	750 Kearns Boulevard #140	Park City	84060	(435) 649-7788
UT	7526	Riddle, Charles M.	5619 S 3500 W	Roy	84067	(801) 985-1899
UT	7527	Rompel, Micheal SC	6900 W 3500 S	West Valley City	84128	(801) 250-5084
UT	7528	Rasmussen, Christopher R.	460 N. Main Street	Heber City	84032	(435) 654-5533
UT	7529	Bywater, Jerald Kymbbel	208 W 200 N	Kaysville	84037	(801) 497-9333
UT	7530	Keetch, Wesley Glen	5345 W 11000 N	Highland	84003	(801) 763-1000
UT	7531	Rompel, Micheal SC	4790 W 3500 S	Salt Lake City	84120	(801) 955-9458
UT	7532	Rompel, Micheal SC	5184 W 13400 S	Herriman	84096	(801) 253-3988
UT	7533	Riddle, Charles M.	1024 N. Main Street #C	Tooele	84074	(435) 833-0606
UT	7535	Keetch, Wesley Glen	2311 Santa Clara Drive, Suite I	Santa Clara	84765	(435) 688-8885
UT	7536	Riddle, Charles M.	1352 E. Center Street	Spanish Fork	84660	(801) 798-0303
UT	7538	Beadles, Jonathon G.	2686 N 1850 W	Farr West	84404	(801) 737-1100
UT	7539	Rompel, Micheal SC	7953 S Airport Road	West Jordan	84088	(385) 255-8080
UT	7543	Keetch, Wesley Glen	410 West State Street	Hurricane	84737	(435) 635-3322
UT	7546	Keetch, Wesley Glen	115 W Main Street	Lehi	84043	(801) 766-3885
UT	7547	Riddle, Charles M.	887 East 100 North #4	Payson	84651	(801) 465-1112
UT	7549	Riddle, Charles M.	167 North 100 West	Cedar City	84720	(435) 586-0600
UT	7550	Beadles, Jonathon G.	1153 N. Main Street	Logan	84341	(435) 753-8770
UT	7551	Bywater, Jerald Kymbbel	1171 S 500 W	Woods Cross	84010	(801) 298-3600
UT	7552	Bywater, Jerald Kymbbel	627 N Marketplace Drive	Centerville	84014	(801) 292-2000
UT	7553	Beadles, Jonathon G.	981 S. Main Street	Logan	84321	(435) 752-8900
UT	7554	Beadles, Jonathon G.	725 W. 1200 S., Suite C	Perry	84302	(435) 734-9200
UT	7555	Keetch, Wesley Glen	987 S. Bluff Street, Unit G	St. George	84770	(435) 628-2228
UT	7556	Avelar, Israel V.	1673 Ute Boulevard	Park City	84098	(435) 800-1299
UT	7557	Riddle, Charles M.	1593 N Redwood Road	Saratoga Springs	84045	(385) 336-2363
UT	7558	Rompel, Micheal SC	5675 W 6200 S	West Valley City	84118	(801) 415-9691
UT	7560	Riddle, Charles M.	3601 Washington Boulevard	South Ogden	84403	(801) 337-4575
UT	7565	Beadles, Jonathon G.	10 West Main	Hyrum	84319	(435) 245-7777
UT	7579	Rompel, Micheal SC	7141 S. Bingham Junction Boulevard, Suite 103	Midvale	84047	(385) 253-8930

Exhibit B Traditional
as of December 31, 2023

UT	7582	Kearns, David	640 East Main Street	Price	84501	(435) 637-3151
UT	7586	Kearns, David	895 W. Highway 40	Vernal	84078	(435) 781-2121
UT	7588	Beadles, Jonathon G.	1 West Main Street	Tremonton	84337	(435) 257-5881
UT	7591	Riddle, Charles M.	1228 S Redwood Road	Salt Lake City	84104	(385) 429-3494
UT	7592	Riddle, Charles M.	901 W. 400 South	Springville	84663	(801) 491-7111
UT	7597	Riddle, Charles M.	225 E Main Street, Suite C	Grantsville	84029	(435) 884-9595
UT	7598	Riddle, Charles M.	1352 Eagle Mountain Boulevard, Unit B	Eagle Mountain	84005	(385) 355-0533
UT	7599	Rasmussen, Christopher R.	200 E. Gateway Drive, Suite 400	Heber City	84032	(435) 534-5533
UT	9101	Keetch, Wesley Glen	293 E Telegraph Street, Suite 108	Washington	84780	(435) 627-6655
UT	9102	Riddle, Charles M.	4095 E. Pony Express Parkway	Eagle Mountain	84005	(801) 789-5999
UT	9103	Riddle, Charles M.	7440 6th Street, Bldg 420	Hill Afb	84056	(801) 773-3023
UT	9104	Keetch, Wesley Glen	1809 W State Road, Suite A-4	Pleasant Grove	84062	(385) 269-2020
UT	9105	Riddle, Charles M.	1274 W University Parkway	Orem	84058	(801) 225-7385
UT	9106	Rompel, Micheal SC	13680 S Redwood Road	Riverton	84065	(801) 704-7600
UT	9108	Bywater, Jerald Kymbel	2274 N 400 E	North Ogden	84414	(801) 317-1812
UT	9109	Riddle, Charles M.	481 E South Temple	Salt Lake City	84103	(385) 429-7676
UT	9110	Keetch, Wesley Glen	2351 South River Road #1	St. George	84790	(435) 656-0005
UT	9111	Riddle, Charles M.	305 S University Avenue	Provo	84601	(385) 482-0111
UT	9112	Keetch, Wesley Glen	101 N 1200 E	Lehi	84043	(385) 352-9099
UT	9113	Rompel, Micheal SC	5642 W 7800 South	West Jordan	84081	(801) 280-7077
UT	9114	Bywater, Jerald Kymbel	420 N 325 E	Harrisville	84404	(385) 389-1414
UT	9115	Rompel, Micheal SC	1961 E Fort Union Boulevard	Cottonwood Heights	84121	(801) 396-7788
UT	9116	Rompel, Micheal SC	3721 W South Jordan Parkway, Suite 120	South Jordan	84009	(385) 274-7806
UT	9117	Riddle, Charles M.	676 North Highway 36, Pad C-3	Stansbury Park	84074	(435) 268-1444
UT	9118	Riddle, Charles M.	1776 N 2000 W	Clinton	84015	(385) 519-1212
UT	9119	Keetch, Wesley Glen	572 W 1600 N, Suite100	Orem	84057	(801) 494-1717
UT	9120	Burgess, Timothy Kent	702 South Main Street, Suite 100	Moab	84532	(435) 259-5555
VA	1335	Shaw, Kevin E.	2113 College Avenue	Bluefield	24605	(276) 326-7070
VA	4200	Miller, Rebecca Lynn	105-C Lew Dewitt Boulevard	Waynesboro	22980	(540) 932-0000
VA	4213	Hess, David F.	6546 Hampton Roads Parkway	Suffolk	23435	(757) 686-5280
VA	4221	Hess, David F.	2048 Atlantic Avenue, Suite B	Chesapeake	23324	(757) 494-7050
VA	4222	Hess, David F.	2616 A Airline Boulevard	Portsmouth	23701	(757) 465-9120
VA	4223	Hess, David F.	540 E. Constance Road	Suffolk	23434	(757) 934-2000
VA	4224	Hess, David F.	2807 E. Virginia Beach Boulevard	Norfolk	23504	(757) 629-0777
VA	4225	Hess, David F.	1201 London Boulevard	Portsmouth	23704	(757) 393-3333
VA	4228	Barber, John C.	7625 Linton Hall Road	Gainesville	20165	(703) 754-3000
VA	4232	Kochensparger, Christopher H.	2433 Colony Crossing Place	Midlothian	23112	(804) 245-8470

Exhibit B Traditional
as of December 31, 2023

VA	4233	Barber, John C.			10054 Sowder Village Square	Manassas	20109	(571) 393-3900
VA	4234	O'Neill, Louis C.			10895 Main Street	Fairfax	22030	(703) 352-9800
VA	4235	Biggar, Shawn R.			36103 Goodwin Drive	Locust Grove	22508	(540) 972-3811
VA	4238	Hurd, Timothy A.			990 E. Main Street	Abingdon	24210	(276) 628-7191
VA	4239	Hamilton, Bryan S.			501 W. 4th Street	Salem	24153	(540) 387-3030
VA	4240	Miller, Rebecca Lynn			1137 Millmont Street	Charlottesville	22903	(434) 971-8383
VA	4241	Miller, Rebecca Lynn			341 Towncenter Lane #300A	Charlottesville	22901	(434) 234-3111
VA	4242	Miller, Rebecca Lynn			508 Stewart Street	Charlottesville	22902	(434) 979-2525
VA	4243	Miller, Rebecca Lynn			1147 5th Street SW	Charlottesville	22902	(434) 970-7777
VA	4244	Kochensparger, Christopher H.			135 N. Madison Road	Orange	22960	(540) 672-2300
VA	4245	Miller, Rebecca Lynn			283 N Central Avenue	Staunton	24401	(540) 885-3311
VA	4246	Durfee, Thomas William			25 S Jefferson Street	Lexington	24450	(540) 463-7375
VA	4247	Angulo, Hayden			10649-A Braddock Road	Fairfax	22032	(703) 352-0990
VA	4248	Miller, Rebecca Lynn			31 Miller Circle	Harrisonburg	22801	(540) 433-2300
VA	4249	Miller, Rebecca Lynn			41 Burgess Road	Harrisonburg	22801	(540) 433-3111
VA	4252	Cobbs, Kenneth L. II			253 East Hundred Road	Chester	23836	(804) 530-5030
VA	4260	Shaw, Kevin E.			970 E. Stuart Drive	Galax	24333	(276) 293-5800
VA	4263	Kochensparger, Christopher H.			9451 Amberdate Drive	Richmond	23636	(804) 276-0330
VA	4264	Cobbs, Kenneth L. II			3085 Boulevard	Colonial Heights	23834	(804) 520-2200
VA	4265	Cobbs, Kenneth L. II			9563-B Kings Charter Drive	Ashland	23005	(804) 550-2555
VA	4266	Barrett, Zachary D.			115 Mall Road	Covington	24426	(540) 724-6500
VA	4267	Barber, John C.			43330 Junction Plaza, Street 118	Ashburn	20147	(703) 729-6100
VA	4268	Barrett, Zachary D.			4930 Greensboro Road	Ridgeway	24148	(276) 250-5100
VA	4269	Hamilton, Bryan S.			5044 Keagy Road, Suite H-110	Roanoke	24018	(540) 900-2323
VA	4270	Shaw, Kevin E.			1655 Roanoke Street	Christiansburg	24073	(540) 585-4010
VA	4271	Shaw, Kevin E.			1589 N. Main Street	Marion	24354	(276) 759-0303
VA	4272	Shaw, Kevin E.			5423 Alexander Road	Dublin	24084	(540) 518-0080
VA	4273	Cobbs, Kenneth L. II			4320 West Hundred Road	Chester	23831	(804) 768-0303
VA	4275	Cobbs, Kenneth L. II			107 Midtown Avenue	Farmville	23901	(434) 392-3000
VA	4276	Barber, John C.			10059 James Madison Highway	Warrenton	20187	(540) 439-0400
VA	4279	Shaw, Kevin E.			165 Kinter Way	Pearisburg	24134	(540) 787-2100
VA	4280	Cobbs, Kenneth L. II			111 Sandy Court, Unit A	Danville	24541	(434) 836-9503
VA	4281	Shaw, Kevin E.			3960 Valley Gateway Boulevard, Suite 5	Roanoke	24012	(540) 982-1555
VA	4282	Shaw, Kevin E.			25 Williamson Road NE	Roanoke	24016	(540) 345-3033
VA	4283	Hamilton, Bryan S.			3021 Brambleton Avenue SW	Roanoke	24015	(540) 772-0020
VA	4284	Barrett, Zachary D.			62 Firstwatch Drive	Moneta	24121	(540) 215-0500
VA	4285	Hurd, Timothy A.			3003A Lee Highway	Bristol	24202	(276) 466-8888

Exhibit B Traditional
as of December 31, 2023

VA	4286	Barrett, Zachary D.	4826 Hollins Road	Roanoke	24019	(540) 366-8080
VA	4287	Shaw, Kevin E.	2362 Peter's Creek Road NW	Roanoke	24017	(540) 562-3030
VA	4288	Barrett, Zachary D.	101 W. Commonwealth Boulevard	Martinsville	24112	(276) 634-5050
VA	4289	Barrett, Zachary D.	2444 Virginia Avenue	Collinsville	24078	(276) 647-7474
VA	4290	Shaw, Kevin E.	905 N. Main Street	Blacksburg	24060	(540) 953-4600
VA	4291	Shaw, Kevin E.	1700 East Main Street	Radford	24141	(540) 639-6144
VA	4292	Shaw, Kevin E.	426 Peppers Ferry Road	Christiansburg	24073	(540) 382-0808
VA	4293	Hamilton, Bryan S.	4145B West Main Street	Salem	24153	(540) 900-4343
VA	4294	Cobbs, Kenneth L. II	3920 Wards Road	Lynchburg	24502	(434) 237-7788
VA	4295	Shaw, Kevin E.	1155 N. 4th Street, Suite 550	Wytheville	24382	(276) 335-0154
VA	4297	Miller, Rebecca Lynn	325 Four Leaf Lane, Suite 5	Crozet	22932	(434) 823-7752
VA	4300	Biggar, Shawn R.	10740 Courthouse Road	Fredericksburg	22408	(540) 891-0303
VA	4302	Boyle, Scott M.	15439 Warwick Boulevard, Suite E	Newport News	23608	(757) 887-3030
VA	4303	Cobbs, Kenneth L. II	731 E Rochambeau Drive	Williamsburg	23188	(757) 585-4646
VA	4309	Barrett, Zachary D.	1500 Main Street	Clifton Forge	24422	(540) 609-5050
VA	4315	O'Neill, Louis C.	6365 Columbia Pike	Falls Church	22041	(571) 348-5400
VA	4316	O'Neill, Louis C.	2972-A Chain Bridge Road	Oakton	22124	(703) 255-0900
VA	4317	O'Neill, Louis C.	698 Elden Street	Hemdon	20170	(703) 689-3200
VA	4318	O'Neill, Louis C.	331 Maple Avenue East	Vienna	22180	(703) 319-3300
VA	4319	O'Neill, Louis C.	1024 Seneca Road, Unit C	Great Falls	22066	(703) 759-0200
VA	4320	Boyle, Scott M.	445 Merrimac Trail #D	Williamsburg	23185	(757) 220-3770
VA	4321	Boyle, Scott M.	1220 Richmond Road	Williamsburg	23185	(757) 229-8885
VA	4323	Palmeri, Christina S.	10817 Tidewater Trail, Suite C	Fredericksburg	22408	(540) 371-4411
VA	4332	Barber, John C.	7732 Richmond Highway	Alexandria	22306	(703) 799-3030
VA	4333	O'Neill, Louis C.	550 N. Quincy Street	Arlington	22203	(703) 276-1400
VA	4334	O'Neill, Louis C.	4698 King Street	Alexandria	22302	(703) 820-0800
VA	4337	Miller, Rebecca Lynn	14809 Spotswood Trail	Elkton	22827	(540) 298-2220
VA	4339	O'Neill, Louis C.	4811 Lee Highway	Arlington	22207	(703) 243-0004
VA	4340	O'Neill, Louis C.	370 S. Pickett Street	Alexandria	22304	(703) 370-4400
VA	4341	O'Neill, Louis C.	2602 Columbia Pike	Arlington	22204	(703) 521-3030
VA	4342	Barber, John C.	8641 Richmond Highway	Alexandria	22309	(703) 360-0700
VA	4343	Barber, John C.	6228 Richmond Highway	Alexandria	22303	(703) 721-0200
VA	4345	O'Neill, Louis C.	7129 Columbia Pike	Annandale	22003	(703) 941-7900
VA	4346	O'Neill, Louis C.	3535 S. Ball Street	Arlington	22202	(703) 684-3344
VA	4347	O'Neill, Louis C.	6138 Arlington Boulevard #C	Falls Church	22044	(703) 533-9000
VA	4348	O'Neill, Louis C.	1106 W. Broad Street, #15	Falls Church	22046	(703) 532-3030
VA	4349	O'Neill, Louis C.	1420 Chain Bridge Road	McLean	22101	(703) 847-0500

Exhibit B Traditional
as of December 31, 2023

VA	4351	Cobbs, Kenneth L. II	7076 Mechanicsville Turnpike	Mechanicsville	23111	(804) 730-9277
VA	4352	Shaw, Kevin E.	1022 East Main Street	Pulaski	24301	(540) 994-0200
VA	4353	Cobbs, Kenneth L. II	401 England Street #17	Ashland	23005	(804) 798-7800
VA	4354	O'Neill, Louis C.	20921 Davenport Drive, Unit 126	Sterling	20165	(703) 430-0900
VA	4355	Palmeri, Christina S.	511 Jefferson Davis Highway	Fredericksburg	22401	(540) 371-3030
VA	4356	Biggar, Shawn R.	4211 D Plank Road	Fredericksburg	22407	(540) 786-8188
VA	4358	Boyle, Scott M.	12840 Jefferson Avenue	Newport News	23608	(757) 877-3030
VA	4359	Hess, David F.	1100 Armory Drive	Franklin	23851	(757) 562-7888
VA	4360	Clise, Michael W.	80 Featherbed Lane	Winchester	22601	(540) 667-3400
VA	4361	Clise, Michael W.	724 Berryville Avenue	Winchester	22601	(540) 665-1911
VA	4363	O'Neill, Louis C.	500 North Henry Street	Alexandria	22314	(703) 548-3030
VA	4364	Zitzer, Scott A.	721 E. Main Street	Luray	22835	(540) 743-4586
VA	4365	Clise, Michael W.	712 N. Commerce Avenue	Front Royal	22630	(540) 635-4171
VA	4366	Miller, Rebecca Lynn	493 West Reservoir Road	Woodstock	22664	(540) 546-0500
VA	4367	Kearney, Andrew	721 Dominion Square	Culpeper	22701	(540) 825-7601
VA	4369	Barber, John C.	6715-K Backlick Road	Springfield	22150	(703) 866-1200
VA	4370	Rodgers, Mark	9532 Old Keene Mill Road	Burke	22015	(703) 644-2226
VA	4371	O'Neill, Louis C.	9127 Lee Highway	Fairfax	22031	(703) 280-5950
VA	4372	Miller, Rebecca Lynn	344 Stoneridge Drive	Ruckersville	22968	(434) 481-5050
VA	4373	Angulo, Hayden	8068 Rolling Road	Springfield	22153	(703) 455-7700
VA	4374	Miller, Rebecca Lynn	1157 Jefferson Highway	Staunton	24401	(540) 609-7100
VA	4376	Cobbs, Kenneth L. II	1020 Bill Tuck Highway, Suites 100 & 200	South Boston	24592	(434) 572-1933
VA	4377	O'Neill, Louis C.	8962 Burke Lake Road	Springfield	22151	(703) 764-2807
VA	4378	Barber, John C.	81 W. Lee Highway	Warrenton	20186	(540) 347-0001
VA	4379	Barber, John C.	7772 Gunston Plaza	Lorton	22079	(703) 550-5100
VA	4380	Barber, John C.	8813 Centreville Road	Manassas	20110	(703) 369-7733
VA	4381	Barber, John C.	944 Edwards Ferry Road NE	Leesburg	20176	(703) 771-9495
VA	4382	O'Neill, Louis C.	3063C Centreville Road	Hemdon	20171	(571) 349-8600
VA	4383	O'Neill, Louis C.	22330 S. Sterling Boulevard, Suite A112	Sterling	20164	(703) 444-4000
VA	4384	Barber, John C.	8130 Ashton Avenue, Suite 103	Manassas	20109	(703) 368-2000
VA	4385	O'Neill, Louis C.	14120 B Lee Highway	Centreville	20120	(703) 830-9000
VA	4386	Kearney, Andrew	595 Madison Road	Culpeper	22701	(540) 825-7600
VA	4387	Barber, John C.	5960 Kingstowne Towne Center Boulevard, Suite 100	Alexandria	22315	(703) 971-3033
VA	4389	O'Neill, Louis C.	13053 Lee Jackson Memorial Highway, Suite 18	Fairfax	22033	(703) 818-7100
VA	4391	Hamilton, Bryan S.	6405-D Merriman Road	Roanoke	24018	(540) 900-0123
VA	4392	O'Neill, Louis C.	8133B Watson Street	McLean	22102	(703) 873-7333
VA	4393	Mendoza, Javier J.	220 Elizabeth Drive	Stephens City	22655	(540) 869-9669

Exhibit B Traditional
as of December 31, 2023

VA	4394	O'Neill, Louis C.	2303-A Soapstone Drive	Reston	22091	(703) 860-4900
VA	4396	Kochensparger, Christopher H.	14834 Hull Street Road	Chesterfield	23832	(804) 739-2444
VA	4397	Cobbs, Kenneth L. II	1000-C Main Street	Altavista	24517	(434) 369-6767
VA	4399	Barber, John C.	22556 Amendola Terrace, Suite 180	Ashburn	20148	(703) 726-0330
VA	6008	Miller, Rebecca Lynn	2927 Stuarts Draft Highway	Stuarts Draft	24477	(540) 337-4200
VA	6012	Cobbs, Kenneth L. II	14521 Forest Road	Forest	24551	(434) 385-0404
VA	6013	Cobbs, Kenneth L. II	1051 Village Highway, Suite G	Rustburg	24588	(434) 332-1135
VA	6014	Boyle, Scott M.	5251 John Tyler Highway, Unit #23	Williamsburg	23185	(757) 258-8788
VA	6015	Miller, Rebecca Lynn	630 North Main Street, Suite E	Bridgewater	22812	(540) 828-1777
VA	6016	Barber, John C.	10175 Hastings Drive	Manassas	20110	(703) 330-8000
VA	6018	Cobbs, Kenneth L. II	164 Camp Creek Parkway	Gordonsville	23093	(540) 920-2999
VA	6032	Palmeri, Christina S.	43 Beachgate Shopping Center 700 McKinney Boulevard	Colonial Beach	22443	(804) 224-2334
VA	6033	Hess, David F.	426 Furr Street	South Hill	23970	(434) 447-7700
VA	6034	Biggar, Shawn R.	840 Warrenton Road	Fredericksburg	22406	(540) 374-1515
VA	6036	Hess, David F.	1933 South Church Street	Smithfield	23430	(757) 357-6710
VA	6038	Hess, David F.	200 Market Drive	Emporia	23847	(434) 634-4040
VA	6043	Barber, John C.	43073 Peacock Market Plaza, Unit 125	South Riding	20152	(703) 327-9999
VA	6045	Palmeri, Christina S.	1749 George Washington Memorial Highway	Gloucester Point	23062	(804) 699-7000
VA	6046	Cobbs, Kenneth L. II	1824 Tappahannock Boulevard	Tappahannock	22560	(804) 443-6585
VA	6048	Barber, John C.	748 E. Main Street	Purcellville	20132	(540) 338-1188
VA	6049	Shoemaker, Larry Jr.	91 Washington Square Plaza, Suite 105	Fredericksburg	22405	(540) 371-7212
VA	6052	Cobbs, Kenneth L. II	210 W. 22nd Street	Buena Vista	24416	(540) 261-1111
VA	6054	Miller, Rebecca Lynn	66 Joshua Lane	Palmyra	22963	(434) 589-5525
VA	6056	Miller, Rebecca Lynn	501 E. Main Street, #116	Louisa	23093	(540) 967-9700
VA	6057	Palmeri, Christina S.	6101 George Washington Memorial Highway	Gloucester	23061	(804) 693-6800
VA	6058	Palmeri, Christina S.	15417- A Dahlgren Road	King George	22485	(540) 644-1414
VA	6096	Miller, Rebecca Lynn	105 S. Timber Way	Broadway	22815	(540) 901-9001
VA	6097	Barrett, Zachary D.	400 Old Franklin Turnpike, Suite 105	Rocky Mount	24151	(540) 483-4140
VA	6108	Palmeri, Christina S.	23 W Church Street	Kilmarnock	22482	(804) 435-3030
VA	6109	Palmeri, Christina S.	17489 Jefferson Davis Highway	Ruther Glen	22546	(804) 448-5588
VA	6162	Cobbs, Kenneth L. II	1390 Broad Street	Oliville	23129	(804) 784-5555
VA	6196	Palmeri, Christina S.	6374 Jefferson Davis Highway, #100	Spotsylvania	22551	(540) 582-7766
VA	6197	Palmeri, Christina S.	7959 Kings Highway	King George	22485	(540) 775-9000
VA	8082	Barber, John C.	5491 Merchants View Square	Haymarket	20169	(571) 261-5800
VA	8083	Cobbs, Kenneth L. II	109 North Bridge Street	Bedford	24523	(540) 587-5555
VA	8084	Cobbs, Kenneth L. II	12130 East Lynchburg (aka Salem Highway), Unit 1&2	Forest	24551	(434) 525-6000
VA	8085	Cobbs, Kenneth L. II	910 Main Street	Lynchburg	24504	(434) 845-6000

Exhibit B Traditional
as of December 31, 2023

VA	8088	Cobbs, Kenneth L. II	1501 Lakeside Drive	Lynchburg	24501	(434) 544-8115
VA	8092	Cobbs, Kenneth L. II	7410 Cooper Tavern Road, Unit D	Quinton	23141	(804) 932-9930
VA	8093	Shaw, Kevin E.	2445 East Washington Avenue, Suite A	Vinton	24179	(540) 491-9991
VA	8094	Palmeri, Christina S.	16631 Mountain Road	Montpelier	23192	(804) 883-7300
VA	8095	Hess, David F.	33 W Windsor Boulevard	Windsor	23487	(757) 242-4949
VA	8096	Cobbs, Kenneth L. II	1405 South Boston Road	Danville	24541	(434) 793-3792
VA	8097	Palmeri, Christina S.	4917 Richmond Tappahannock Highway, Suite #7	Aylett	23009	(804) 769-7000
VA	8281	Cobbs, Kenneth L. II	196 Ambriar Plaza	Amherst	24521	(434) 946-0606
VA	8295	Barber, John C.	5976 12th Street	Fort Belvoir	22060	(703) 360-0027
VA	8296	Cobbs, Kenneth L. II	61 Tuskegee Airman Boulevard	Langley AFB	23665	(757) 766-2000
VA	8323	Barber, John C.	24650 South Point Drive, Suite 110	Chantilly	20152	(571) 399-6300
VA	8395	Barrett, Zachary D.	50 Market Center Way	Daleville	24083	(540) 904-0494
VA	8396	Cobbs, Kenneth L. II	7101 Forest Hill Avenue, Suite U	Richmond	23225	(804) 327-1633
VA	8397	Cobbs, Kenneth L. II	3207 Forest Brook Road	Lynchburg	24501	(434) 385-1100
VA	8399	Barber, John C.	20020-20070 Ashbrook Commons Plaza	Ashburn	20147	(571) 353-3030
VA	8450	Cobbs, Kenneth L. II	1965 Confederate Boulevard	Appomattox	24522	(434) 352-5252
VA	8479	O'Neill, Louis C.	5663 Stone Road, Suite 18	Centreville	20120	(571) 549-1900
VA	8495	Shaw, Kevin E.	2165 Bennington Street	Roanoke	24014	(540) 595-0675
VT	3049	Jarvis, Timothy R.	167 Route 7	Milton	05468	(802) 893-3333
VT	3101	Litwhiler, Michael	485 Colchester Avenue	Burlington	05401	(802) 658-3333
VT	3102	Litwhiler, Michael	10 Farrell Street	S Burlington	05403	(802) 658-5667
VT	3103	Litwhiler, Michael	58A Pearl Street	Essex Junction	05452	(802) 878-1111
VT	3104	Litwhiler, Michael	140 Strongs Avenue	Rutland	05701	(802) 775-0044
VT	3105	Litwhiler, Michael	1548 North Avenue	Burlington	05401	(802) 658-6558
VT	3106	Bell, Keith	322 N. Main Street	Barre	05641	(802) 479-2222
VT	3107	Jarvis, Timothy R.	266 North Main Street	St. Albans	05478	(802) 527-5333
VT	3108	Zonfrilli, Joseph V.	748 Main Street	Bennington	05201	(802) 442-5550
VT	3122	Bell, Keith	124 Springfield Plaza Road	Springfield	05156	(802) 277-5500
VT	3135	Litwhiler, Michael	201 Comerstone Drive	Williston	05495	(802) 232-2777
VT	3164	Bell, Keith	25 Berlin Street	MONTPELIER	05602	(802) 229-7777
VT	3166	Bell, Keith	33 Railroad Square	Newport	05855	(802) 673-1333
VT	3195	Zonfrilli, Joseph V.	499 Canal Street	Brattleboro	05301	(802) 257-5010
VT	3231	Hunt, Travis William	250 Railroad Street	St Johnsbury	05819	(802) 748-3555
VT	9940	Litwhiler, Michael	3424 Roosevelt Highway	Colchester	05446	(802) 231-1500
WA	7000	Farmer, Patrick D.	134 N. 1st Street	Shelton	98584	(360) 427-8700
WA	7018	Keller, Gregory S.	24437 Russell Road, Suite 102	Kent	98032	(253) 859-7899
WA	7019	Keller, Gregory S.	1140 Galaxy Drive NE, Suite H	Lacey	98516	(360) 456-1812
WA	7020	Farmer, Patrick D.	20631 Bothell Everett Highway, Suite J	Bothell	98012	(425) 481-4848

Exhibit B Traditional
as of December 31, 2023

WA	7021	Hancock, Bryan Gregory	22219 Mountain Highway East	Spanaway	98387	(253) 617-3223
WA	7022	Keller, Gregory S.	20 SW 7th Street, Suite B	Renon	98057	(425) 793-5002
WA	7023	Keller, Gregory S.	4025 A Street SE, Suite 103	Auburn	98002	(253) 275-1266
WA	7024	Brown, Michael W.	3840 Pacific Avenue East, Suite C.101	Tacoma	98418	(253) 501-7555
WA	7027	Hancock, Bryan Gregory	3710 Factoria Boulevard SE, Suite C	Bellevue	98006	(425) 747-9766
WA	7028	Farmer, Patrick D.	9815 State Avenue, Suite #B	Marysville	98270	(360) 653-8088
WA	7030	Farmer, Patrick D.	22941 Highway 99, Unit #A	Edmonds	98026	(425) 776-3030
WA	7031	Gaube, Steve	3289 SE Lund Avenue, Suite #101	Port Orchard	98366	(360) 871-9000
WA	7032	Gaube, Steve	23969 NE Highway 3 #G	Belfair	98528	(360) 233-2266
WA	7035	Anderson, Shane H.	2901 N. Argonne Road	Millwood	99212	(509) 926-3555
WA	7037	Keller, Gregory S.	2600 N.W. Randall Way, #115	Silverdale	98383	(360) 692-4040
WA	7038	Gaube, Steve	14122 92nd Ave NW, Suite 1	Gig Harbor	98329	(253) 525-2100
WA	7039	Gaube, Steve	4800 Pt. Fostick Drive	Gig Harbor	98335	(253) 851-1020
WA	7040	Farmer, Patrick D.	2619 Simpson Avenue	Hoquiam	98550	(360) 533-3500
WA	7041	Alexander, Steven	19679 State Route 410 E.	Bonney Lake	98391	(253) 862-3100
WA	7042	Anderson, Shane H.	604 S. Sullivan Road	Spokane Valley	99037	(509) 927-4992
WA	7043	Hancock, Bryan Gregory	462 228th Avenue NE	Sammamish	98074	(425) 836-2720
WA	7044	Anderson, Shane H.	10507 W. Aero Road, Suite 2	Spokane	99224	(509) 408-2000
WA	7045	Hamilton, Troy C.	6300 NE 117th Avenue B8	Vancouver	98662	(360) 254-4408
WA	7046	Farmer, Patrick D.	19150 NE Woodinville Duvall Road, Suite A-5	Woodinville	98077	(425) 844-3030
WA	7047	Keller, Gregory S.	2800 Milton Way	Milton	98354	(253) 927-0303
WA	7048	Hancock, Bryan Gregory	10223 132nd Street E, Suite 104	Puyallup	98374	(253) 840-3000
WA	7049	Anderson, Shane H.	North 9329 Division	Spokane	99218	(509) 468-2000
WA	7050	Farmer, Patrick D.	19819 State Route 2	Monroe	98272	(360) 805-9090
WA	7051	Keller, Gregory S.	19689 7th Avenue NE	Poulsbo	98370	(360) 779-1020
WA	7052	Farmer, Patrick D.	118 Ferry Street	Sedro Woolley	98284	(360) 855-1000
WA	7053	Keller, Gregory S.	1719 22nd Avenue, Suite B	Seattle	98122	(206) 712-1504
WA	7055	Farmer, Patrick D.	303 91st Avenue NE, Suite A -101	Lake Stevens	98258	(425) 377-9000
WA	7056	Hamilton, Troy C.	3512 NE 3rd Avenue	Camas	98607	(360) 835-1500
WA	7057	Keller, Gregory S.	3220 California Avenue SW	Seattle	98116	(206) 926-4191
WA	7058	Walter, Eldon R.	1704 S. Gold Street	Centralia	98531	(360) 347-6000
WA	7059	Walter, Eldon R.	533 Custer Way SE, Suite B	Tumwater	98501	(360) 754-0000
WA	7060	Farmer, Patrick D.	2027 196th Street SW, Suite R-6	Lynnwood	98036	(425) 744-0303
WA	7061	Farmer, Patrick D.	1019 Yakima Valley Highway	Sunnyside	98944	(509) 836-2300
WA	7062	Farmer, Patrick D.	6830 Bothell Way NE	Bothell	98028	(425) 806-0303
WA	7063	Keller, Gregory S.	714 Taylor Avenue North	Seattle	98109	(206) 285-7000
WA	7067	Singh, Ananpreet	755 W. Washington Street, Suite B	Sequim	98382	(360) 582-1600
WA	7068	Anderson, Shane H.	1235 N. Liberty Lake Drive #107	Liberty Lake	99019	(509) 444-4242
WA	7069	Farmer, Patrick D.	3704 172nd Street NE, Suite O	Arlington	98223	(360) 659-1120

Exhibit B Traditional
as of December 31, 2023

WA	7070	McCluskey, Matthew Shane	4001 Kennedy Road, Suite 10	West Richland	99353	(509) 627-2000
WA	7072	Hamilton, Troy C.	11 NW 12th Avenue, Suite 113	Battle Ground	98604	(360) 667-0667
WA	7073	Farmer, Patrick D.	8195 Guide Meridian Street	Lynden	98264	(360) 325-7676
WA	7076	Hancock, Bryan Gregory	9805 224th Street, Suite E	Graham	98338	(253) 847-8393
WA	7077	Keller, Gregory S.	7034 State Highway 303	Bremerton	98311	(360) 698-3232
WA	7078	Farmer, Patrick D.	1863 Main Street, Suite 103	Ferndale	98248	(360) 380-2100
WA	7079	Walter, Eldon R.	10501 Creek Street SE	Yelm	98597	(360) 400-2222
WA	7080	Farmer, Patrick D.	3425 Birch Bay Lynden Road	Custer	98240	(360) 366-4200
WA	7082	Keller, Gregory S.	Bldg 11574 A Street	Fort Lewis	98433	(253) 964-3030
WA	7083	Bulkley, Scott Arthur	845 NE Monroe Street	Pullman	99163	(509) 332-1555
WA	7084	Keller, Gregory S.	4717 Brooklyn Avenue NE	Seattle	98105	(206) 525-9551
WA	7085	Farmer, Patrick D.	13119 Seattle Hill Road, Building 3, Suite 108	Shohomish	98296	(425) 379-8000
WA	7086	Hancock, Bryan Gregory	7328 Better Way SE, Suite 110	Shoquialmie	98065	(425) 888-1676
WA	7087	Farmer, Patrick D.	402 36th Street	Bellingham	98225	(360) 671-8282
WA	7088	Hancock, Bryan Gregory	16929 SE 270th Place, Suite B-102	Covington	98042	(253) 630-0000
WA	7089	Keller, Gregory S.	5401 Corporate Center Loop SE	Lacey	98503	(360) 455-7073
WA	7090	Walter, Eldon R.	3225 Harrison Avenue NW, Suite 107	Olympia	98502	(360) 357-2277
WA	7091	Hancock, Bryan Gregory	11416 Canyon Road E, Suite F	Puyallup	98373	(253) 536-6640
WA	7092	Brown, Michael W.	805 Pacific Avenue	Tacoma	98402	(253) 272-0800
WA	7093	Keller, Gregory S.	1800 South Jackson, Suite D	Seattle	98144	(206) 325-3230
WA	7094	Keller, Gregory S.	2320 North 45th Street, Suite B	Seattle	98103	(206) 632-0700
WA	7095	Keller, Gregory S.	11025 5th Ave NE	Seattle	98125	(206) 362-3103
WA	7096	Farmer, Patrick D.	506 South First Street, Suite A	Selah	98942	(509) 955-3344
WA	7097	Hughes, Kevin	595 Grant Road, Suite 595-1	East Wenatchee	98802	(509) 436-7000
WA	7098	Farmer, Patrick D.	8431 122nd Avenue N.E.	Kirkland	98033	(425) 549-3030
WA	7100	Rodgers, Samantha	7007 Burden Boulevard, Suite 101	Pasco	99301	(509) 316-4400
WA	7101	Brown, Michael W.	2602 N Stevens Street	Tacoma	98407	(253) 752-2300
WA	7102	Brown, Michael W.	1905 Bridgeport Way W., Unit D (Suite 108)	University Place	98466	(253) 565-5050
WA	7103	Brown, Michael W.	8442 Pacific Avenue	Tacoma	98444	(253) 531-6611
WA	7104	Brown, Michael W.	12221 Pacific Avenue	Tacoma	98444	(253) 535-5000
WA	7105	Brown, Michael W.	3735 S. Pine Street	Tacoma	98409	(253) 473-5450
WA	7106	Hancock, Bryan Gregory	615 E. Pioneer Way, Suite 101	Puyallup	98372	(253) 841-7833
WA	7108	Keller, Gregory S.	2317 S.W. 336th Street	Federal Way	98023	(253) 952-3030
WA	7111	Hancock, Bryan Gregory	16260 Redmond Way, Suite 2	Redmond	98052	(425) 885-3030
WA	7112	Keller, Gregory S.	4802 Pacific Highway E	Fife	98424	(253) 235-0854
WA	7113	Keller, Gregory S.	620 Auburn Way S	Auburn	98002	(253) 939-3030
WA	7114	Keller, Gregory S.	6621 South 21st Street, Suite #102	Kent	98032	(253) 480-6700
WA	7115	Keller, Gregory S.	4538 Martin Way E.	Olympia	98503	(360) 459-9090

Exhibit B Traditional
as of December 31, 2023

WA	7116	Hancock, Bryan Gregory	23714 222nd Place SE, Suite D	Maple Valley	98038	(425) 432-3000
WA	7120	Singh, Amanpreet	1210-B East Front Street	Port Angeles	98362	(360) 452-4222
WA	7121	Keller, Gregory S.	3168 2nd Division Drive	Fort Lewis	98433	(253) 589-3030
WA	7122	Brown, Michael W.	10812 Bridgeport Way SW	Lakewood	98499	(253) 581-3531
WA	7123	Farmer, Patrick D.	17425 Highway 99, Suite G	Lynnwood	98037	(425) 743-3030
WA	7124	Brandt, Dean	270 SE Cabot Drive, Suite 1	Oak Harbor	98277	(360) 679-4141
WA	7125	Farmer, Patrick D.	7601 Evergreen Way, Suite B4	Everett	98203	(425) 347-2202
WA	7126	Keller, Gregory S.	1426 S 324th Street, Suite 108A	Federal Way	98003	(253) 946-9494
WA	7127	Keller, Gregory S.	3720 Kitsap Way	Bremerton	98312	(360) 373-2020
WA	7128	Keller, Gregory S.	24050 Pacific Highway S.	Kent	98032	(253) 839-4412
WA	7129	Alexander, Steven	26019 104th Avenue SE, Suite #104	Kent	98030	(253) 852-3030
WA	7130	Hancock, Bryan Gregory	15920 NE 8th Street, Suite 5	Bellevue	98008	(425) 644-9444
WA	7132	Hancock, Bryan Gregory	16420 Meridian Avenue E, Suite 103	Puyallup	98375	(253) 289-6161
WA	7134	Farmer, Patrick D.	1801 Broadway Avenue	Everett	98201	(425) 367-5030
WA	7135	Keller, Gregory S.	14901 4th Avenue SW	Burien	98166	(206) 248-3030
WA	7136	Keller, Gregory S.	4110 Wheaton Way	Bremerton	98310	(564) 654-4110
WA	7137	Keller, Gregory S.	16260 Military Road S., Suite 113	SeaTac	98188	(206) 242-4444
WA	7139	Farmer, Patrick D.	13501 100th Avenue NE, Suite 10	Kirkland	98034	(425) 820-4660
WA	7142	Keller, Gregory S.	6540 California Avenue SW, Suite B	Seattle	98136	(206) 932-0995
WA	7143	Anderson, Shane H.	830 S. Main Avenue	Deer Park	99006	(509) 651-2000
WA	7144	Keller, Gregory S.	1427 Broadway	Seattle	98122	(206) 860-9900
WA	7145	Keller, Gregory S.	4436 Rainier Avenue South	Seattle	98118	(206) 721-5596
WA	7147	Farmer, Patrick D.	302 North 125th Street	Seattle	98133	(206) 363-3911
WA	7148	Keller, Gregory S.	8345 15th Avenue NW, Suite A	Seattle	98117	(206) 297-6757
WA	7149	Farmer, Patrick D.	20030 Ballinger Way NE	Shoreline	98155	(206) 365-6011
WA	7150	Anderson, Shane H.	16017 E. Trent Avenue	Spokane Valley	99216	(509) 887-4992
WA	7153	Farmer, Patrick D.	2517 Commercial Avenue	Anacortes	98221	(360) 873-6771
WA	7155	Bhatti, Akashdeep Singh	4020 NE 4th Street, Suite B	Renton	98056	(425) 235-6000
WA	7156	Farmer, Patrick D.	3930 Meridian Street, Suite 102	Bellingham	98226	(360) 671-1050
WA	7157	Hancock, Bryan Gregory	10575 NE 12th Street	Bellevue	98004	(425) 453-7200
WA	7160	England, Ronald D.	710 N. Anderson Street	Ellensburg	98926	(509) 925-3800
WA	7161	Farmer, Patrick D.	1423 Avenue D	Shonomish	98290	(360) 822-9994
WA	7162	Alexander, Steven	17160 116th Avenue SE, Suite 1	Renton	98058	(425) 235-7000
WA	7163	Farmer, Patrick D.	1600 East College Way	Mt. Vernon	98273	(360) 428-6800
WA	7164	Farmer, Patrick D.	1903 S. 3rd Avenue	Yakima	98903	(509) 453-3000
WA	7165	Hines, Timothy	4707 W. Clearwater Avenue	Kennewick	99336	(509) 735-6377
WA	7166	Hines, Timothy	1408 Jadwin Avenue	Richland	99354	(509) 943-2500
WA	7167	McCluskey, Matthew Shane	3802 West Court Street	Pasco	99301	(509) 547-9999

Exhibit B Traditional
as of December 31, 2023

WA	7168	Stidham, Daniel R.	2 E. 1Street Avenue	Kennewick	99336	(509) 586-1000
WA	7169	Hancock, Bryan Gregory	1175 NW Gliman Boulevard, Suite B4	Issaquah	98027	(425) 392-1003
WA	7170	Farmer, Patrick D.	6 Union Street	Yakima	98901	(509) 248-1000
WA	7171	Farmer, Patrick D.	420 S. 72nd Avenue, Suite 140	Yakima	98908	(509) 965-1500
WA	7172	Keller, Gregory S.	2928 1st Avenue	Seattle	98121	(206) 456-6848
WA	7173	Hughes, Kevin	402-A E Broadway	Moses Lake	98837	(509) 765-6555
WA	7174	Keller, Gregory S.	112 1st Avenue South, Suite 100	Seattle	98104	(206) 445-0999
WA	7175	Farmer, Patrick D.	1036 Washington Way	Longview	98632	(360) 636-6000
WA	7176	Walter, Eldon R.	1241 Harrison Avenue	Centralia	98531	(360) 807-6000
WA	7177	Hamilton, Troy C.	7735 NE Highway 99	Vancouver	98665	(360) 574-4040
WA	7178	Hamilton, Troy C.	1723 NE Andresen	Vancouver	98661	(360) 885-3030
WA	7179	Hamilton, Troy C.	1006 W Fourth Plain Boulevard	Vancouver	98660	(360) 696-2100
WA	7180	Hamilton, Troy C.	14125 SE Mill Plain Boulevard	Vancouver	98684	(360) 253-0060
WA	7181	Farmer, Patrick D.	1233 164th Street SW	Lynwood	98037	(425) 409-0086
WA	7182	Anderson, Shane H.	5620 S. Regal	Spokane	99223	(509) 535-2433
WA	7183	Anderson, Shane H.	2108 E. Wellesley Avenue	Spokane	99207	(509) 487-2100
WA	7184	Anderson, Shane H.	510 S. Thor Avenue	Spokane	99202	(509) 747-4992
WA	7185	McCluskey, Matthew Shane	517 S. 9th Avenue	Walla Walla	99362	(509) 527-8800
WA	7186	Hughes, Kevin	211 W. 5th Street	Wenatchee	98801	(509) 663-4681
WA	7187	Anderson, Shane H.	1320 N. Hamilton	Spokane	99202	(509) 534-1910
WA	7188	Anderson, Shane H.	5525 N. Alberta Street	Spokane	99205	(509) 326-8300
WA	7189	Anderson, Shane H.	603 W. 3rd Avenue	Spokane	99201	(509) 327-5502
WA	7190	Hamilton, Troy C.	2903 E. 4th Plain Boulevard	Vancouver	98661	(360) 787-4242
WA	7191	Hamilton, Troy C.	13712 NE 20th Avenue, Suite 1	Vancouver	98686	(360) 718-3700
WA	7192	Anderson, Shane H.	12622 Highway 2 (aka Sunset Highway)	Airway Heights	99001	(509) 244-2555
WA	7193	Anderson, Shane H.	11510 E. Sprague Avenue, Suite A	Spokane Valley	99206	(509) 922-5200
WA	7194	Anderson, Shane H.	1879 First Street	Cheney	99004	(509) 235-2000
WA	7195	Keller, Gregory S.	8208 NE State Highway 104, Suite 107	Kingston	98346	(360) 633-1798
WA	7196	Keller, Gregory S.	9610 - 17th Avenue SW	Seattle	98106	(206) 225-2315
WA	7197	Alexander, Steven	1402 1st Street	Enumclaw	98022	(360) 284-4028
WA	9425	England, Ronald D.	364 Chardonnay Avenue, Suite #1 & #2	Prosser	99350	(509) 781-6550
WA	9426	Farmer, Patrick D.	3708 Ocean Beach Highway	Longview	98632	(360) 442-4882
WA	9427	Keller, Gregory S.	4219 S Othello Street, Suite 105-B	Seattle	98118	(206) 508-0404
WA	9428	Hancock, Bryan Gregory	15127 Main Street East, Suite 105	Sumner	98390	(253) 299-8488
WA	9430	Brown, Michael W.	8225 Steilacoom Boulevard SW	Lakewood	98498	(253) 777-1077
WA	9431	Farmer, Patrick D.	11632 Highway 99, Suite H	Everett	98204	(425) 953-5330
WA	9432	Gaube, Steve	423 SW Sedgwick Road, Suite 101	Port Orchard	98367	(360) 895-7777
WA	9433	Hamilton, Troy C.	4101 SE 192nd Avenue	Vancouver	98683	(360) 726-4040

Exhibit B Traditional
as of December 31, 2023

WI	2000	Green, Troy A.	1204 Belknap Street	Superior	54880	(715) 394-7777
WI	2001	Hanson, Dean	1009 W. Wisconsin Street	Sparta	54656	(608) 269-3333
WI	2003	Burton, Nathaniel P.	8115 Sheridan Road	Kenosha	53143	(262) 771-0707
WI	2004	Burton, Nathaniel P.	4370 67th Drive	Union Grove	53182	(262) 420-4763
WI	2005	Hanson, Dean	2402 State Road	Lacrosse	54601	(608) 788-3030
WI	2006	Burton, Nathaniel P.	5100 Washington Avenue	Racine	53405	(262) 637-7000
WI	2007	Forder, Mark W.	2388 State Road 35, Unit 5	Osceola	54020	(715) 417-3110
WI	2008	Baretz, Douglas W.	7190 S. 76th	Franklin	53132	(414) 425-1511
WI	2009	Forder, Mark W.	1114 N. Superior Avenue, Suite A	Tomah	54660	(715) 972-2020
WI	2010	Forder, Mark W.	1157 E Division Avenue	Barron	54812	(715) 418-2700
WI	2013	Baretz, Douglas W.	1585 W. Main Street	Sun Prairie	53590	(608) 825-3200
WI	2014	Graves, Susan L.	2530 Lineville Road, #2	Green Bay	54313	(920) 393-7575
WI	2015	Baretz, Douglas W.	4680 Cottage Grove Road	Madison	53716	(608) 222-2800
WI	2017	Lockhart, Eric J.	490 Highway 151 E.	Platteville	53818	(608) 348-3060
WI	2018	Baretz, Douglas W.	519 Cottonwood	Hartland	53029	(262) 367-5444
WI	2020	Lambert, Adam K.	2581 Post Road	Plover	54467	(715) 544-8262
WI	2021	Scheel, Jason D.	1260 Milton Avenue	Janesville	53545	(608) 758-8888
WI	2022	Scheel, Jason D.	2200 West Court Street	Janesville	53548	(608) 728-8080
WI	2024	Baretz, Douglas W.	N168W2724 Prairie View Lane	Jackson	53037	(262) 674-1321
WI	2025	Baretz, Douglas W.	1256 W. Capitol Drive, Suite 800	Pewaukee	53072	(262) 696-6440
WI	2026	Lambert, Adam K.	1703 Marinette Avenue	Marinette	54143	(715) 735-3900
WI	2027	Baretz, Douglas W.	17305 W. Capitol Drive	Brookfield	53045	(262) 790-8900
WI	2028	Baretz, Douglas W.	148 South Foster Drive	Saukville	53080	(262) 284-5522
WI	2029	Graves, Susan L.	1179 S. Washburn Street	Oshkosh	54904	(920) 235-2200
WI	2030	Graves, Susan L.	2301 Jackson Street	Oshkosh	54901	(920) 233-3030
WI	2031	Lambert, Adam K.	728 Fond du Lac Street	Ripon	54971	(920) 748-7272
WI	2032	Graves, Susan L.	206 W. Calumet Street	Appleton	54915	(920) 380-4030
WI	2033	Graves, Susan L.	333 W. Northland Avenue	Appleton	54911	(920) 738-9680
WI	2034	Graves, Susan L.	436 S. Commercial Street	Neenah	54956	(920) 725-6656
WI	2035	Graves, Susan L.	84 N. Main Street	Fond Du Lac	54935	(920) 921-3800
WI	2036	Burton, Nathaniel P.	58 W. Market Street, Suite H	Elkhorn	53121	(262) 578-5150
WI	2037	Graves, Susan L.	819 Schelfhout Lane #101	Kimberly	54136	(920) 687-9790
WI	2040	Lambert, Adam K.	3033 Church Street	Stevens Point	54481	(715) 345-0901
WI	2041	Lambert, Adam K.	122 S. Central Avenue	Marshfield	54449	(715) 387-3771
WI	2042	Lambert, Adam K.	3910 Schofield Avenue	Schofield	54476	(715) 359-3030
WI	2043	Lambert, Adam K.	301 S. 2nd Avenue	Wausau	54401	(715) 848-2776
WI	2044	Troullier, P. Ann	2880 8th Street S	Wisconsin Rapids	54494	(715) 423-5555
WI	2046	Lambert, Adam K.	704 E. Green Bay Street	Shawano	54166	(715) 524-3030

Exhibit B Traditional
as of December 31, 2023

WI	2047	Lord, Robert A.			711 N. Spring Street, B	Beaver Dam	53916	(920) 356-0551
WI	2048	Baretz, Douglas W.			719 W. Wisconsin Avenue	Milwaukee	53233	(414) 271-8990
WI	2050	Lanier, H. Michel			1719 N. Clairemont Avenue	Eau Claire	54703	(715) 833-3930
WI	2051	Lanier, H. Michel			3311 London Drive	Eau Claire	54701	(715) 833-3933
WI	2052	Lanier, H. Michel			705 S. Broadway	Menomonie	54751	(715) 232-6333
WI	2053	Lanier, H. Michel			354 Chippewa Mall Drive	Chippewa Falls	54729	(715) 726-2626
WI	2054	Baretz, Douglas W.			3500 W. Capitol Drive	Milwaukee	53216	(414) 539-3409
WI	2055	Forder, Mark W.			609 N. Water Street	Black River Falls	54615	(715) 629-9700
WI	2056	Peterson, Wayne A.			118 N. Main Street	River Falls	54022	(715) 425-5306
WI	2057	Lord, Robert A.			906 S. Main Street	West Bend	53095	(262) 334-5577
WI	2058	Peterson, Wayne A.			706 19th Street	Hudson	54016	(715) 386-8099
WI	2060	Vandevort, Lynn A.			1910 Washington	Manitowoc	54220	(920) 683-3881
WI	2061	Graves, Susan L.			2670 Monroe Road, Suite 4	Green Bay	54311	(920) 337-4850
WI	2062	Graves, Susan L.			2448 University Avenue	Green Bay	54302	(920) 468-4700
WI	2063	Graves, Susan L.			550 Military Avenue	Green Bay	54303	(920) 496-6020
WI	2064	Graves, Susan L.			2815 S. Oneida Street, Suite D	Green Bay	54304	(920) 494-9555
WI	2065	Baretz, Douglas W.			6918 N. Teutonia	Milwaukee	53209	(414) 352-5522
WI	2066	Scheel, Jason D.			1009 E. Main Street	Watertown	53094	(920) 262-3030
WI	2067	Baretz, Douglas W.			5430 N. Lovers Lane Road	Milwaukee	53225	(414) 462-8070
WI	2068	Baretz, Douglas W.			1338 W. Forest Home Avenue	Milwaukee	53204	(414) 645-3303
WI	2070	Baretz, Douglas W.			1107 N. 14th Avenue	Sheboygan	53081	(920) 457-1500
WI	2071	Baretz, Douglas W.			2400 W. Ryan Road	Oak Creek	53154	(414) 949-6025
WI	2072	Baretz, Douglas W.			26 S. Highland Avenue	Plymouth	53073	(920) 893-4800
WI	2074	Baretz, Douglas W.			2149 S. Miller Parkway	W. Milwaukee	53219	(414) 644-5444
WI	2076	Baretz, Douglas W.			S74 W16829 W. Janesville Road	Muskego	53150	(414) 422-4800
WI	2077	Baretz, Douglas W.			1828 N. Farwell Avenue	Milwaukee	53202	(414) 249-5901
WI	2078	Baretz, Douglas W.			7131 W. Capital Drive	Milwaukee	53216	(414) 462-8999
WI	2079	Baretz, Douglas W.			6015 W. Forest Home Avenue	Milwaukee	53220	(414) 763-3597
WI	2080	Baretz, Douglas W.			6915 University Avenue	Middleton	53562	(608) 824-0800
WI	2081	Baretz, Douglas W.			5401 Caddis Bend	Fitchburg	53711	(608) 284-9565
WI	2083	Baretz, Douglas W.			385 Falls Road	Grafton	53024	(262) 618-2672
WI	2085	Burton, Nathaniel P.			2815 Durand Avenue	Racine	53403	(262) 383-3636
WI	2087	Baretz, Douglas W.			7613 W. Good Hope Road	Milwaukee	53223	(414) 357-7775
WI	2088	Baretz, Douglas W.			325 E. North Street #4	Waukesha	53188	(262) 542-9330
WI	2090	Burton, Nathaniel P.			204 Park Avenue	Beloit	53511	(608) 312-2474
WI	2091	Burton, Nathaniel P.			3743 Douglas Avenue	Racine	53404	(262) 681-6111
WI	2092	Baretz, Douglas W.			3139 N. Oakland	Milwaukee	53211	(414) 332-6888
WI	2093	Baretz, Douglas W.			10922 W. National Avenue	West Allis	53227	(414) 546-1000

Exhibit B Traditional
as of December 31, 2023

WI	2096	Baretz, Douglas W.	920 Greenwald Court, Suite 200	Mukwonago	53149	(262) 363-3663
WI	2097	Baretz, Douglas W.	409 West Gorham Street	Madison	53703	(608) 255-2222
WI	2099	Cahee, Danny L. Jr.	8744 US Highway 51 N., Suite 3	Minocqua	54548	(715) 356-4242
WI	2100	Burton, Nathaniel P.	1311 Madison Avenue	Fort Atkinson	53538	(920) 563-5663
WI	2101	Forder, Mark W.	2570 Gracie Drive, Suite 102	Baldwin	54002	(715) 688-3030
WI	2102	Burton, Nathaniel P.	2088 Milwaukee Avenue, Unit F	Burlington	53105	(262) 767-0210
WI	2104	Scheel, Jason D.	750 E. Wisconsin Avenue	Oconomowoc	53066	(262) 569-6999
WI	2105	Burton, Nathaniel P.	7519 60th Avenue, Suite 150	Kenosha	53142	(262) 697-8247
WI	2106	Baretz, Douglas W.	2181 E. Rawson Avenue	Oak Creek	53154	(414) 764-7100
WI	2107	Hanson, Dean	224 Sand Lake Road	Onalaska	54650	(608) 781-3345
WI	2108	Baretz, Douglas W.	737 S. Gammon Road	Madison	53719	(608) 276-7676
WI	2109	Graves, Susan L.	106 Shaler Drive	Waupun	53963	(920) 324-6111
WI	2110	Lord, Robert A.	N112 W15800 West Mequon Road	Germanatown	53022	(262) 502-1818
WI	2111	Graves, Susan L.	4733 Michael's Drive	Grand Chute	54913	(920) 731-0100
WI	2112	Baretz, Douglas W.	6300 W Brown Deer Road	Brown Deer	53223	(414) 236-5622
WI	2113	Erwin, Allan F.	622 Washington Street	Horicon	53032	(920) 485-4555
WI	2114	Lambert, Adam K.	247 Broadway Street	Berlin	54923	(920) 361-7272
WI	2115	Nelson, Harold J.	844 8th Avenue	Baraboo	53913	(608) 355-5080
WI	2116	Carlson, Duane L. Jr.	301 Main Street West	Ashland	54806	(715) 292-6602
WI	2117	Erwin, Allan F.	584 Wisconsin Dells Parkway South	Wisconsin Dells	53965	(608) 253-1900
WI	2118	Lambert, Adam K.	400 N. Shawano Avenue	New London	54961	(920) 982-7700
WI	2120	Forder, Mark W.	1215 E. Elm Street	Cumberland	54829	(715) 564-9900
WI	2121	Cahee, Danny L. Jr.	623 Lincoln Street	Rhineland	54501	(715) 362-2525
WI	2122	Forder, Mark W.	1657 Doman Drive	New Richmond	54017	(715) 246-3030
WI	2124	Burton, Nathaniel P.	1823 E. Geneva Street, Unit H	Delavan	53115	(262) 728-8888
WI	2195	Burton, Nathaniel P.	96 East Geneva Square	Lake Geneva	53147	(262) 248-5050
WI	2197	Lord, Robert A.	46 South Main Street	Hartford	53027	(262) 670-8811
WI	9700	Burton, Nathaniel P.	2701 18th Street	Kenosha	53140	(262) 551-0595
WI	9701	Baretz, Douglas W.	803 N. Mayfair Road	Wauwatosa	53226	(414) 935-4000
WI	9702	Baretz, Douglas W.	4221 W. North Avenue	Milwaukee	53208	(414) 444-5100
WI	9703	Burton, Nathaniel P.	1139 W. Main Street	Whitewater	53190	(262) 473-0707
WI	9704	Baretz, Douglas W.	6111 W. Mequon Road, Suite D	Mequon	53092	(262) 236-0069
WI	9705	Forder, Mark W.	602 South Main Street	Rice Lake	54868	(715) 719-0630
WI	9706	Baretz, Douglas W.	15169 W. National Avenue	New Berlin	53121	(262) 788-9111
WI	9707	Baretz, Douglas W.	2810 East Washington Avenue	Madison	53704	(608) 241-4646
WI	9708	Lord, Robert A.	N85 W15768 Appleton Avenue	Menomonee Falls	53051	(262) 250-1212
WI	9709	Baretz, Douglas W.	552 West Layton Avenue	Milwaukee	53221	(414) 533-4000
WI	9710	Forder, Mark W.	830 Rivard Street, Suite 400	Somers	54025	(715) 247-3040

Exhibit B Traditional
as of December 31, 2023

WV	9711	Lambert, Adam K.	1020 W. Fulton Street	Waupaca	54981	(715) 544-8400
WV	1300	Graves, Susan L.	75 Valley Pointe Drive, Unit 300	Elkins	26241	(304) 630-3030
WV	1301	Graves, Susan L.	3100 Grand Central Avenue	Vienna	26105	(304) 295-9321
WV	1303	Graves, Susan L.	1814 7th Street	Parkersburg	26101	(304) 485-7501
WV	1305	Clise, Michael W.	71 Cowardly Lion Drive	Hedgesville	25427	(681) 258-8330
WV	1307	Graves, Susan L.	1001 Morgantown Avenue	Fairmont	26554	(304) 366-7881
WV	1308	Graves, Susan L.	130 US Highway 33 E	Weston	26452	(304) 269-3030
WV	1309	Graves, Susan L.	47 S. Kanawha Street	Buckhannon	26201	(304) 472-3030
WV	1311	Graves, Susan L.	1159 Van Voorhis Road, Suite A	Morgantown	26505	(304) 241-5545
WV	1315	Lacefield, Morgan T.	1331 Pennsylvania Avenue	Weirton	26062	(304) 797-7222
WV	1316	Graves, Susan L.	300 Pleasant Street	Morgantown	26501	(304) 296-3030
WV	1318	Graves, Susan L.	5468 Big Tyler Road	Cross Lanes	25313	(304) 776-3030
WV	1319	Graves, Susan L.	1631 Washington Street E.	Charleston	25311	(304) 343-3100
WV	1322	Graves, Susan L.	116 S. Chestnut Street	Clarksburg	26301	(304) 624-4001
WV	1323	Graves, Susan L.	2308 Cleveland Avenue	Saint Albans	25177	(304) 727-2284
WV	1325	Graves, Susan L.	701 Oakwood Road	Charleston	25314	(304) 345-0300
WV	1329	Lacefield, Morgan T.	275 N. State Route 2	New Martinsville	26155	(304) 455-1180
WV	1331	Lacefield, Morgan T.	144 N. Lafayette Avenue	Moundsville	26041	(304) 845-9065
WV	1333	Lacefield, Morgan T.	77 Bridge Street Plaza	Wheeling	26003	(304) 242-1200
WV	1334	Lacefield, Morgan T.	3030 Jacob Street	Wheeling	26003	(304) 232-3030
WV	1336	Shaw, Kevin E.	700 Stafford Drive	Princeton	24740	(304) 425-0505
WV	1339	Clise, Michael W.	Route 11 N. (aka 502 Williamsport Pike)	Martinsburg	25401	(304) 263-3000
WV	1340	Graves, Susan L.	420 Viand Street	Point Pleasant	25550	(304) 675-5858
WV	1341	Johnson, Claude E	205 Creel Street	St. Mary's	26170	(304) 684-2684
WV	1342	Johnson, Claude E	344 S. Church	Ripley	25271	(304) 372-1600
WV	1343	Horn, John	23 Nell Jean Square	Beckley	25801	(304) 256-3003
WV	1344	Horn, John	160 South Pointe Drive	Fayetteville	25840	(304) 465-3030
WV	1345	Lacefield, Morgan T.	326 S. 4th Avenue	Paden City	26159	(304) 337-2223
WV	1346	Lacefield, Morgan T.	1130 North Fork Road	West Liberty	26003	(304) 336-4400
WV	1347	Clise, Michael W.	65-D Cordial Court	Falling Waters	25419	(304) 274-3010
WV	1349	Clise, Michael W.	490 N. High Street	Romney	26757	(304) 822-3866
WV	1350	Clise, Michael W.	1002 Winchester Avenue	Martinsburg	25401	(304) 267-7600
WV	1351	Clise, Michael W.	201 N. Mildred Street	Ranson	25438	(304) 725-2095
WV	1352	Clise, Michael W.	590 S. Mineral Street	Keyser	26726	(304) 788-6400
WV	1353	Clise, Michael W.	8309 Martinsburg Pike	Shepherdstown	25443	(304) 876-2595
WV	1354	Clise, Michael W.	33 True Apple Way	Inwood	25428	(304) 229-2121
WV	1356	Horn, John	1932 Ritter Drive	Daniels	25832	(304) 763-5300
WV	1360	Lacefield, Morgan T.	457 Main Street	Follansbee	26037	(304) 527-3030

Exhibit B Traditional
as of December 31, 2023

WV	1361	Graves, Susan L.	525 20th Street	Huntington	25703	(304) 697-3300
WV	1362	Graves, Susan L.	941 Roosevelt Boulevard	Eleanor	25070	(304) 586-2500
WV	1363	Graves, Susan L.	450 E. Main Street	Bridgeport	26330	(304) 848-2525
WY	6001	Feavel, Jay B.	511 E Pershing	Cheyenne	82001	(307) 637-3030
WY	6002	Feavel, Jay B.	3610 Dell Range Boulevard, Unit A3	Cheyenne	82009	(307) 635-3030
WY	6003	Hackett, Michael D.	2741 West C Street	Torrington	82240	(307) 532-0330
WY	6004	Hahn, Anna	1826 E Richards	Douglas	82633	(307) 624-2020
WY	6005	Erwin, Allan F.	451 West Coulter	Powell	82435	(307) 754-3211
WY	6006	Feavel, Jay B.	901 S. Greeley Highway, Unit A	Cheyenne	82007	(307) 222-1149
WY	6007	Erwin, Allan F.	309 Lakeway Road	Gillette	82718	(307) 682-5999
WY	6010	Riddle, Charles M.	233 Front Street	Evanston	82930	(307) 789-7899
WY	6019	Riddle, Charles M.	312 W. Cedar Street	Rawlins	82301	(307) 328-1400
WY	6020	Feavel, Jay B.	1710 Grand Avenue	Laramie	82070	(307) 742-0030
WY	6030	Riddle, Charles M.	3028 College Drive	Rock Springs	82901	(307) 362-4242
WY	6031	Riddle, Charles M.	430 Uinta Drive	Green River	82935	(307) 875-2020
WY	6035	Riddle, Charles M.	804 N Federal Boulevard	Riverton	82501	(307) 857-2033
WY	6040	Moran, Frank B.	1540 Centennial Court	Casper	82609	(307) 237-6100
WY	6041	Moran, Frank B.	3141 SW Wyoming Boulevard	Casper	82604	(307) 265-2900
WY	6042	Moran, Frank B.	813 E First Street	Casper	82601	(307) 234-4455
WY	6050	Erwin, Allan F.	400 W 2nd Street	Gillette	82716	(307) 682-4999
WY	6051	Erwin, Allan F.	1538 N. Main Street	Sheridan	82801	(307) 672-7401
WY	6055	Mueller, Jodilyn	520 South Highway 89	Jackson	83001	(307) 733-0330
WY	6059	Riddle, Charles M.	175 N. 4th Street	Lander	82520	(307) 335-7070
WY	6060	Erwin, Allan F.	1454 Sheridan Avenue	Cody	82414	(307) 587-4781
WY	6098	Erwin, Allan F.	307 East Hart Street, Suite C	Buffalo	82834	(307) 620-3061
WY	6099	Feavel, Jay B.	5410 Yellowstone Rd	Cheyenne	82009	(307) 475-7555
WY	7678	McComas, Sean E.	550 Washington Street, Suite 130	Afton	83110	(307) 368-8833
Guam	97351	Noble, Jay	393 S Marine Corps Drive	Tamuning	96913	(671) 646-3030
Guam	97352	Noble, Jay	Route 10 Suite 104	Mangilao	96913	(671) 734-1030
Guam	97353	Noble, Jay	Yigo Market Place, 525 North Marine Corps Drive	Yigo	96929	(671) 653-3030
Guam	97355	Noble, Jay	185 Mepa Street	Dededo	96929	(671) 637-3030
Guam	97356	Noble, Jay	Navy Exchange Guam Bldg. 258, Unit 102	Navy Station	96915	(671) 564-3030
Guam	97357	Noble, Jay	135 Marine Corp Drive	Dededo	96929	(671) 647-3030
Guam	97358	Noble, Jay	165 Route 4	Hagatna	96915	(671) 477-3030
Puerto Rico	11651	Lieberman, Ed	Ponce de Leon Shopping Center, Local #1 Avenue Lopategui Esq.	Guaynabo	00969	(787) 720-3030
Puerto Rico	11652	Lieberman, Ed	Carr #2 KM 7.3	Guaynabo	00983	(787) 720-3030
Puerto Rico	11654	Lieberman, Ed	Avenue Monserrate Monserrate Plaza Local F	Carolina	00983	(787) 720-3030
Puerto Rico	11655	Lieberman, Ed	Avenue Campo Rico #235	Carolina	00982	(787) 720-3030

Exhibit B Traditional
as of December 31, 2023

Puerto Rico	11656	Lieberman, Ed		A-4 Calle 1 Renville	Bayamón	00956	(787) 720-3030
Puerto Rico	11658	Lieberman, Ed		RA-16 Avenue / Boulevard	Levittown Toa Baja	00961	(787) 795-4000
Puerto Rico	11659	Lieberman, Ed		AS-56 Calle 37 Santa Juanita	Bayamón	00956	(787) 740-5500
Puerto Rico	11660	Oliver, Felix		Urb University Gardens 266, Avenue Pinero	San Juan	00927	(787) 767-3131
Puerto Rico	11666	Lieberman, Ed		1908 Calle Loiza	Santurce	00911	(787) 726-3035
Puerto Rico	11668	Lieberman, Ed		Central Plaza Shopping Center, Local 14 Avenue San Patricio	San Juan	00920	(787) 273-3030
Puerto Rico	11669	Baez, Madeline		Avenue San Claudio #387, Local #1	San Juan	00957	(787) 740-8585
Puerto Rico	11670	Lieberman, Ed		Drive Inn Plaza Shopping Center #19	Bayamón	00957	(787) 740-8585
Puerto Rico	11672	Lieberman, Ed		1357 Avenue Ponce de León Parada 20	Santurce	00915	(787) 725-3000
Puerto Rico	11674	Lieberman, Ed		Edif Office Park I Local 208	Mayaguez	00680	(787) 831-3030
Puerto Rico	11676	Lieberman, Ed		125 Avenue Universidad	Arecibo	00612	(787) 878-3030
Puerto Rico	11677	Lieberman, Ed		Plaza Nuevo Mundo #5B	Ponce	00731	(787) 259-3030
Puerto Rico	11678	Lieberman, Ed		155 Calle Comerío	Hatillo	00657	(787) 820-3030
Puerto Rico	11679	Lieberman, Ed		Carr 155 KM 70	Santa Isabel	00757	(787) 845-3434
Puerto Rico	11680	Lieberman, Ed		Puerta del Sol Shopping Center	Manatí	00674	(787) 854-4000
Puerto Rico	11681	Lieberman, Ed		Carr 107 KM 4.7	Aguadilla	00605	(787) 891-7000
Puerto Rico	11682	Lieberman, Ed		Fajardo Plaza Punta del Este Court 194	Fajardo	00738	(787) 863-3131
Puerto Rico	11683	Lieberman, Ed		Vega Baja Mall, Carr #2, KM 39.3, Local DD5	Vega Baja	00693	(787) 855-5000
Puerto Rico	11684	Lieberman, Ed		Plaza del Noreste Mall Villas de Loiza, Local 2-B	Loiza	00772	(787) 886-3030
Puerto Rico	11685	Lieberman, Ed		Urb Buzo, Calle Dr. Victor Rincon #1 Local A	Humacao	00982	(787) 852-3535
Puerto Rico	11686	Lieberman, Ed		PR 14, KM 73.3, Int. Carr. 1 Bo. Montebello	Cayey	00736	(787) 263-3330
Puerto Rico	11687	Lieberman, Ed		245 Ave Mendez Vigo	Dorado	00740	(787) 796-3030
Puerto Rico	11688	Lieberman, Ed		Plaza Notre Dame Local 7 Avenue Luis Muñoz Marín	Caguas	00725	(787) 703-3030
Puerto Rico	11690	Lieberman, Ed		Edif Económuble #2 El Tuque	Ponce	00731	(787) 984-3030
Puerto Rico	11693	Lieberman, Ed		Plaza Encantada Local C6 Ave. Encantada	Trujillo Alto	00979	(787) 293-3030
Puerto Rico	11694	Lieberman, Ed		Yauco Gallery Carr #2 KM 2.2	Yauco	00698	(787) 492-3030
Puerto Rico	11696	Lieberman, Ed		Olympic Plaza Shopping Center CARR PR 30 INT PR 198 KM 20.01	Las Piedras	00771	(787) 716-3030
Puerto Rico	11697	Lieberman, Ed		Commerce Plaza Carr. 744 Esq. Highway 54	Guayama	00787	(787) 866-5555
Puerto Rico	11699	Lieberman, Ed		Edif. Estacionamiento Covadonga, Local 14	San Juan	00921	(787) 724-3030
Puerto Rico	15170	Airport Shoppes, Corp.		Aeropuerto Luis Muñoz Marín Ave Aeropuerto	Carolina	00979	(787) 791-0300
Puerto Rico	15171	Airport Shoppes, Corp.		Aeropuerto Luis Muñoz Marín Ave Aeropuerto	Carolina	00979	(787) 791-0300
Puerto Rico	15172	Airport Shoppes, Corp.		Aeropuerto Luis Muñoz Marín Ave Aeropuerto	Carolina	00979	(787) 791-0300
Puerto Rico	15173	Lieberman, Ed		9 Avenue Chardón Local 3	San Juan	00918	(787) 767-0101
Puerto Rico	15175	Lieberman, Brian and Zachary		Carr 2 Int Avenue Hostos Lote 1 Mall Ponce by Pass	Ponce	00721	(787) 928-8585
Puerto Rico	15176	Lieberman, Brian and Zachary		Avenue Nativo ATERS, Town Center, Local #3	Aguada	00602	(787) 551-8900
Puerto Rico	15177	Lieberman, Brian and Zachary		The Market Place at Montehiedra, Ave. Los Romeros, Local 6 3 2-A	San Juan	00926	(787) 200-7444
Puerto Rico	15178	Lieberman, Brian and Zachary		Carr. PR #3, 65 Infantería Shopping Center, Store #9-6/1	San Juan	00924	(787) 767-2666
Puerto Rico	15179	Lieberman, Brian and Zachary		Carr. PR #3, Km. 28, Centro Comercial Río Grande Plaza, Local 56	Río Grande	00745	(787) 957-3232

Exhibit B Traditional
as of December 31, 2023

Puerto Rico	15180	Lieberman, Brian and Zachary	Carr. PR 52 Las Catalinas Shopping Center #109	Caguas	00727	(787) 286-3030
Virgin Islands	16172	Lieberman, Brian and Zachary	3000 Golden Rock Shopping Center, Suite 5	Christiansted	00820	(340) 773-6040
Virgin Islands	16173	Lieberman, Brian and Zachary	8000 Nisky Center Shopping Center, Suite 6	St. Thomas	00802	(340) 776-3030
Franchise Agreements Signed but Outlet Not Opened as of December 31, 2023						
AL	5361	Ford, Grant Forrester	225 W. College Street	Columbiana	35051	
AL	5372	Dhedhi, Danish W.	3630 Gordon Terry Parkway, Unit 1	Trinity	35673	(256) 280-4200
CA	7819	Hosseini, Dariush	1601 W. 17th Street Unit F-1	Santa Ana	92706	
CO	7622	Rea, Michael S.	6996 Highway 2	Commerce City	80022	
FL	3111	Lopez Velarde, Nefi Fernando Padilla	69 US Highway 17/92 N.	Haines City	33844	
FL	3853	Meade, Dwayne Wayne	6005 US-301	Hawthorne	32640	
FL	5197	Sherrick, Keith W.	3238 Citrus Tower Boulevard	Clermont	34711	
IN	2717	Manzanares, Wayne Tyler Eugene	1027 West 7th Street	Auburn	46706	(618) 263-6000
KY	1463	Ratterman, Mark B.	125 South English Station Road	Louisville	40245	(606) 341-0003
MA	3077	Gokdag, Celal Fatih	70 Main Street	Hopkinton	01748	(508) 506-8401
NE	1768	DelGrosso, Brian	610 Glover Road, Suite 1	Sidney	69162	(308) 203-4123
OR	7107	Vandenbergh, Bruce M.	2128 Main Street	Sweet Home	97386	
SC	5644	Kerns, Joe Brice	9105 Bowen Pier Drive	Hanahan	29410	(843) 885-8686
TX	8136	Abdelmotal, Elsadig M.	19003 Windsor Pointe Drive, Suite #400	Tomball	77375	
TX	9438	Brwon, Randy L. Sr.	8711 FM 1049, Suite D	Mont Belvieu	77523	(346) 241-7995
UT	9975	Kearns, David	28 E. 450 N. Main Street	Ephraim	84627	(888) 233-4003

EXHIBIT B-1

LIST OF DOMINO'S FRANCHISEES – NON-TRADITIONAL

Exhibit B-1 Non-Traditional
as of December 31, 2023

Store State	Store	Franchisee	Area Type	Store Address	Store City	Store Zip	Store Phone
AL	5381	Dawoud, Mohammed (David)		7201 Aaron Aronov Drive, Suite #30	Fairfield	35064	(205) 923-2626
AL	5824	Dhedhi, Danish W.		700 Monroe Street SW	Huntsville	35801	(256) 534-7300
CA	8535	Hishmeh, Tareq M.		2198 Riverside Avenue (Mid-State Fairgrounds)	Paso Robles	93446	(805) 895-4082
FL	3297	Reulbach, Anthony S.		525 N. Summit Street	Crescent City	32112	(386) 698-1500
FL	8623	Longen, Jerry A.		University of Florida Stadiums	Gainesville (Univ of Fla)	32611	(352) 373-3343
FL	8637	Stoeke, Jr., Arthur L.		Univ. of Central Florida - JTW Center, 114 Aquarius	Orlando	32816	(407) 882-2010
GA	8886	Nagengast, Michael P.		Route 2 Box 96, Highway 82	Waynesville	31566	(912) 778-8888
IN	2607	Stegen, Jeffrey		610 Purdue Mall	West Lafayette	47907	(765) 497-7890
KS	6327	Cunningham, Donal		Building 6914 Warren Road	Fort Riley	66442	(785) 762-2121
LA	5206	Rigsby, Jerrod Glenn		2310 N. Main Street, Suite #100	St. Martinville	70582	(337) 394-4040
MO	1541	Hurteau/Prather, Art/Marty		Hammons Field, 935 E. Trafficway Street	Springfield	65802	(417) 865-8443
MS	5987	Magee, Gregory S.		221 Highway 26 West	Poplarville	39470	(601) 403-8500
NC	7482	Patterson, G. Mack		Bank of America Stadium - 800 S. Mint Street	Charlotte	28202	N/A
NC	8815	Barber, John C.		60-3 Cronley Road	Delco	28436	(910) 655-0808
NC	8835	Heaney, Sean T.		926 Brookstown Avenue	Winston Salem	27101	(336) 768-9545
NC	8838	Patterson, G. Mack		BB&T Ballpark- 324 South Mint Street	Charlotte	28202	(980) 636-2330
NM	6547	Bailey, Brian K.		Shiprock QuikStop, Highway 64, PO Box 3379	Shiprock, Navajo Nation	87420	(505) 368-4907
NM	9300	Bailey, Brian K.		Tse Bonito NNOG Convenience Store, Highway 2	Tse Bonito, Navajo Nation	87301	(505) 371-3600
SC	8756	Fox, Aaron A.		848 Pamplico Highway	Pamplico	29583	(843) 493-3030
TN	6174	Hurd, Timothy A.		Bristol Motor Speedway - 151 Speedway Boulevard	Bristol	37620	N/A
Guam	97354	Noble, Jay		Tract 1427, A.B. Wonpat International Airport	Tamuning	96911	(671) 642-3030

EXHIBIT B-2

**LIST OF FRANCHISEES WHO HAVE LEFT THE SYSTEM
OR WHO HAVE CLOSED OR TRANSFERRED A UNIT
BUT HAVE NOT LEFT THE SYSTEM**

Exhibit B-2
Franchisees Who Left the System as of December 31, 2023

Franchisee	Address	City	State	Zip	Phone
Abdelmotal, Elsadig M.	3532 Mclean Road	Pearland	TX	77584	(713) 416-5566
Aguilera, Francisco Benito	19160 SW 317th Terrace	Homestead	FL	33030	(305) 915-5125
Al-Farah, Ayed T.	4855 N. Odell Court	Harwood Heights	IL	60706	(773) 772-9000
Ambrosi, Stephen J.	66 Joshua Lane	Palmyra	VA	22963	(434) 806-7698
Anderson, Shane H.	726 W. 3rd Avenue	Spokane	WA	99201	(509) 327-5502
Anis, Furqan	P.O. Box 531	Carnegie	PA	15106	(724) 561-9411
Armistead, John D.	1941 Tarragon Lane	New Port Richey	FL	34655	(727) 791-3030
Arntson, Eric	4800 W. Saginaw Highway, Suite A	Lansing	MI	48917	(517) 575-7344
Askew, Henry G.	P.O. Box 850	Scituate	MA	02066	(781) 378-1704
Atar, Murat	99 Clinton Avenue	Clifton	NJ	07011	(862) 571-1407
Bailey, Brian K.	1114 S. Union Avenue	Roswell	NM	88203	(575) 637-3030
Baker, Christopher J.	12304 State Route 93 N.	Logan	OH	43138	(740) 380-0037
Barber, John C.	5896 Waterloo Bridge Circle	Haymarket	VA	20169	(703) 785-5571
Baretz, Douglas W.	11050 W. Bluemound Road	Wauwatosa	WI	53226	(414) 443-6402
Barrett, Zachary D.	3745 Dogwood Lane SW	Roanoke	VA	24015	(540) 353-6311
Bell, Keith	P.O. Box 1220	Lebanon	NH	03766	(802) 505-8244
Bhullar, Khushminder S.	4 Freedom Court	Mechanicsburg	PA	24551	(484) 553-0320
Black, Eric Robert	1717 Christy Drive	Jefferson City	MO	65101	(573) 496-5470
Blalock, William D.	P.O. Box 410517	Melbourne	FL	32941	(321) 777-4433
Botrice, Morice B.	6309 North Hamlin	Chicago	IL	60659	(773) 279-8509
Bower, Brian Patrick	5420 NW 90th Street	Johnston	IA	50131	(719) 229-0777
Briggs, Robert A.	810 County Road 13A South	Elkton	FL	32033	(561) 797-0251
Brown, Michael W.	P.O. Box 8087	Tacoma	WA	98419	(253) 474-4831
Brown, Randy L. Sr.	P.O. Box 749	Orange	TX	77631	(409) 886-1717
Burnham, Mason	2305 Milan Meadows	Leander	TX	78641	(214) 929-1305
Burrow, Brian D.	7977 Hills and Dales Road NE	Massillon	OH	44646	(330) 833-8555
Burton, Erik J.	4033 Beverly Drive	Onalaska	WI	54650	(608) 783-3327
Carraway, Mary Lynne	1600 Spring Hill Road, Suite 100	Vienna	VA	22182	(703) 298-6912
Carrigan, Benjamin Eli	3561 Midland Trail	Bell Buckle	TN	37020	(615) 427-0898
Cates, Daniel P.	3993 Scenic Drive	Eugene	OR	97404	(503) 881-4181
Cecere, Robert A.	13 Emerson Drive	Morganville	NJ	07751	(732) 703-0431
Cesarini, David L.	25 Jackson Industrial Drive, Suite 600	Ann Arbor	MI	48103	(734) 476-9386
Conway, Steven P.	27 Charter Oak Drive	Athens	GA	30607	(706) 255-1314
Cunningham, Donal	201 W Greenway Street #364	Derby	KS	67037	(316) 616-5235
Cunningham, Michael A.	12633 State Highway 30	College Station	TX	77845	(979) 695-9912
Dain, The Estate of Daniel W.	2345 Pollex Avenue	Corpus Christi	TX	78410	(361) 356-6220
D'Andrea, Peter P.	P.O. Box 23347	Knoxville	TN	37933	(704) 905-9220
Davis, Bradley C.	2205 Kirkwood Street	High Point	NC	27262	(336) 889-1044
Delgado, Donna L.	1562 Owens Valley Drive	Woodland	CA	95776	(530) 756-5161
Desjardins, Marc	36 Crowthers Place	Hope Valley	RI	02832	(401) 849-6940
Dhedhi, Wahid I.	14520 Memorial Drive, Suite M136	Houston	TX	77079	(281) 701-6894
Dobb, Bryan W.	2132 Benson Road	Point Roberts	WA	98281	(604) 952-4500
Dolan, Charles S.	5804 Ward Road #B	Arvada	CO	80004	(303) 431-2400
Doster, Robert	238 Pristine Lane	Port Angeles	WA	98362	(360) 452-7349
Dumais, Michelle A.	2909 108th Street	Lubbock	TX	79423	(806) 762-8832

Exhibit B-2
Franchisees Who Left the System as of December 31, 2023

Franchisee	Address	City	State	Zip	Phone
Dunlop, Randy	942 W. Willson Street	Niota	TN	37826	(423) 572-1105
Dutton, Paul L.	26 Rock Lane	Milton	PA	17847	(570) 275-9514
Duvall, Samuel Edward	667 Lincoln Avenue	Charleston	IL	61920	(417) 766-0493
Dyrda, Todd P.	5348 Hill Road NW	Acworth	GA	30101	(404) 401-3307
Erwin, Allan F.	1542 N Main	Sheridan	WY	82801	(307) 250-3063
Farmer, Patrick D.	2314 SE 146th Avenue	Vancouver	WA	98683	(360) 581-6903
Feavel, Jay B.	2649 E. Mulberry #5	Fort Collins	CO	80524	(970) 416-8868
Fischer, Douglas Mark	1408 NE 5th Street	Moore	OK	73160	(405) 681-9525
Fischler, Jarred S.	5200 Villa Rosa Avenue	Saint Cloud	FL	34771	(407) 694-8506
Forder, Mark W.	1151 E. Division Avenue	Barron	WI	54812	(715) 246-3030
Fox, Gregory B.	4034 Enterprise Way, Suite 180	Flowery Branch	GA	30542	(770) 967-6967
Funderburg, Dain F.	301 Junction Highway #346	Kerrville	TX	78028	(830) 257-4840
Gage, Stanley J.	P.O. Box 12921	New Bern	NC	28561	(734) 276-3068
Glass, John B.	P.O. Box 17597	Covington	KY	41017	(513) 886-2641
Good, Aleja	4707 N. Harlem Avenue	Harwood Heights	IL	60706	(708) 308-7745
Grapes, Ronald L. Jr.	5495 State Road T	Stoutland	MO	65567	(417) 286-3409
Graves, Susan L.	3905 High Trail Court	Flower Mound	TX	75022	(320) 295-3637
Gross, David A.	10830 NW 80 Circle	Parkland	FL	33076	(954) 288-0691
Hahn, The Estate of Carl N.	6908 Egyptian Drive	Fort Collins	CO	80525	(970) 295-4990
Hamill, R. Brent	5314 Paylor Lane	Lakewood Ranch	FL	34240	(941) 907-6667
Hamilton, Bryan S.	933 Emory Church Road	Knoxville	TN	37922	(540) 293-0306
Hamilton, Troy C.	7735 NE Higway 99	Vancouver	WA	98665	(360) 605-0890
Hayman, Kerri-Lea	1870 Shellring Circle	Mt. Pleasant	SC	29466	(843) 371-1510
Herpy, Keith	574 Crown Mountain Way	Dahlongega	GA	30533	(402) 371-0107
Hines, Timothy	4707 West Clearwater Avenue	Kennewick	WA	99336	(509) 735-6377
Hishmeh, Tareq M.	4899 W. Dove Nest Place	Marana	AZ	85658	(520) 323-3500
Hodges, Jerry D.	3440 Ocean Boulevard	Coos Bay	OR	97420	(541) 269-1000
Holte, Bruno P.	1350 Spruce Avenue	Atwater	CA	95301	(209) 722-8022
Hosseini, Dariush	6029 Bristol Parkway, Suite #200	Culver City	CA	90230	(310) 473-6575
Houseman, Patricia A.	421 East Vine Street	Murfreesboro	TN	37130	(615) 893-0078
Huber, Rick A.	415 16th Avenue SW	Minot	ND	58701	(701) 838-8383
Hurd, Timothy A.	4036 Lakeland Drive	Kingsport	TN	37664	(423) 246-4040
Hurteau/Prather, Art/Marty	4042 W Republic Road	Battlefield	MO	65619	(417) 865-8443
Iqbal, Mohammed	73 Tyler Hill Road	Naugatuck	CT	06770	(203) 723-6653
Jali, Ammar	2299 Brodhead Road, Suite C2	Bethlehem	PA	18020	(484) 851-3415
Jandrew, Brian K.	125 N. Congress Avenue #13	Delray Beach	FL	33445	(561) 826-0883
Jenks / Benvenuti, David / Dominic	100 Conifer Hill Drive, Suite 402	Danvers	MA	01923	(978) 777-8044
Joarder, Mohammed Shamsuzzam	651 Clinton Avenue	Haddonfield	NJ	07110	(856) 375-2008
Johnson, Corey L.	413 W. Washington Street	Brainerd	MN	56401	(218) 828-5066
Kearns, David	5792 Vistancia Drive	Parker	CO	80134	(435) 781-2121
Keller, Gregory S.	P.O. Box 2690	Silverdale	WA	98383	(360) 830-0354
Khan, Mohammad S.	441 Main Street, Suite 200	East Orange	NJ	07018	(973) 672-9900
Khokhar, Mohammad I.	36 Franklin Avenue	Nutley	NJ	08087	(973) 667-2222
Knoblock, The Estate of Leonard L.	714 Galway Drive	Bethel Park	PA	15102	(412) 605-2146
Kraniger, Mark J.	P.O. Box 938	La Puente	CA	91747	(626) 369-5752

Exhibit B-2
Franchisees Who Left the System as of December 31, 2023

Franchisee	Address	City	State	Zip	Phone
Lambert, Adam K.	1401 N 26th Street, Suite 219	Escanaba	MI	49829	(208) 877-4992
Lewis, Thomas R.	11555 Central Parkway, Suite 901	Jacksonville	FL	32224	(904) 997-9411
Lieberman, Ed	Local 218 Avenue Gobernadores Isla Verde	Carolina	PR	979	(787) 253-0200
Liezert, Brian	601 Jack Clay Road	Danville	GA	31017	(904) 997-9411
Lindeman, Kenneth R.	P.O. Box 429	Wheaton	IL	60187	(630) 215-4555
Litwhiler, Michael	239 Park Road	South Burlington	VT	05403	(802) 734-7050
Longen, Jerry A.	4030 Henderson Boulevard #386	Tampa	FL	33629	(813) 690-2761
Maddox, Jeffrey W.	3212 Foxridge Circle	Manhattan	KS	66503	(785) 537-3800
Manos, Anthony P.	15198 Downey Avenue	Paramount	CA	90723	(562) 663-1400
May, Roy Jeffrey	P.O. Box 517	Gulf Breeze	FL	32562	(850) 444-9673
McCormick, The Estate of Mitchel A	P.O. Box 530397	Harlingen	TX	78553	(956) 428-6296
McManus, Phillip	2096 N Heritage Street	Buckeye	AZ	85396	(575) 973-0600
McMullen, Timothy Y.	2510 Orchard Circle Drive, Apartment #18	Traverse City	MI	49686	(231) 527-8059
Mehaffey, Paul G.	5847 Sunny Ridge Trail	Clemmons	NC	27012	(336) 766-0566
Melson, James	6020 Robbs Drive	Cumming	GA	30041	(678) 294-3146
Miller, Rebecca Lynn	204 W. Hampton Street	Staunton	VA	24401	(540) 213-3900
Mohtashemi, Paul M.	7867 Mercer Pike	Meadville	PA	16335	(814) 333-4300
Mueller, Glenn A.	15384 5th Street	Gulfport	MS	39503	(228) 832-4000
Mullins, Erin M.	12830 State Road 62	Parrish	FL	34219	(352) 373-3343
Murph, Alan D.	1277 NE Loop 410	San Antonio	TX	78209	(210) 590-1437
Muser, David C.	20090 Lake View Drive	Ste. Genevieve	MO	63670	(573) 883-9959
Nazarian, George	15147 Marlin Place	Van Nuys	CA	91405	(818) 653-5107
Nies, Timothy C.	30025 - 145th Street NW	Princeton	MN	55371	(763) 856-0333
Orsted, Russell K. Sr.	408 Emerald Court	Mary Esther	FL	32569	(850) 803-8920
Palmer, Steven T.	430 Churchhill Lane	Pottsboro	TX	75076	(903) 464-9933
Pardy, James A.	54 Contour Road	Warwick	RI	02886	(401) 467-3130
Patalano, Anthony P. Jr.	26 Chadbourne Circle	Ludlow	MA	01056	(413) 246-8191
Pesta, Edward Carl	4237-103 Louisburg Road	Raleigh	NC	27604	(919) 872-7222
Peterson, Wayne A.	3140 Neil Armstrong Boulevard, Suite 321	Eagan	MN	55121	(651) 289-3000
Podsen, The Estate of Joseph M.	P.O. Box 333	Fairburn	GA	30213	(404) 254-5600
Poe, Dennis	15447 SE Bradford Road	Clackamas	OR	97015	(971) 279-3776
Port, Sheldon R. Jr.	5530 E Pleasant Valley Boulevard	Tyrone	PA	16686	(814) 644-7444
Poulsen, Jamie S.	3901 Blue Ridge Cutoff	Kansas City	MO	64133	(816) 407-9079
Powers, John M.	P.O. Box 6207	Sparta	TN	38583	(931) 837-9999
Price, Richard W.	2490 Aurora Road	Melbourne	FL	32935	(321) 723-9057
Prouse, Donald M. Jr.	120 Mullet Run	Milford	DE	19963	(302) 424-1600
Qasim, S. Osman	122 Avalon Drive, Suite G	Salisbury	NC	28146	(704) 636-7612
Ramia, Jose Y.	P.O. Box 493210	Leesburg	FL	34749	(407) 230-7288
Ratterman, Mark B.	201 North Main, Suite 300	Saint Charles	MO	63301	(636) 947-4433
Redies, Thomas D.	10400 Milford Road	Holly	MI	48442	(734) 368-3302
Reulbach, Anthony S.	610 Brookfield Terrace	Deland	FL	32724	(386) 717-3017
Riddle, Charles M.	14328 S. Log Home Lane	Herriman	UT	84096	(801) 518-7732
Ridge, John E. Jr.	1712 US 401 S	Laurinburg	NC	13340	(910) 280-8255
Rompel, Micheal SC	339 Coral Street	Honolulu	HI	96813	(808) 744-9900
Ross, Daryl S.	2752 Monte Carlo Court	Eustis	FL	32726	(352) 383-1010

Exhibit B-2
Franchisees Who Left the System as of December 31, 2023

Franchisee	Address	City	State	Zip	Phone
Salido, Fernando	216 W. Village Boulevard, Suite 301	Laredo	TX	78041	(956) 717-5720
Satterwhite, Anthony D.	9087 Ichabod Drive	North Ridgeville	OH	44039	(216) 258-1960
Schweitzer, Michael H.	1044 Moon Ranch Road	Florence	TX	76527	(512) 778-9350
Scott, Michael F.	1031 S. Washington Street	Bismarck	ND	58504	(701) 255-7924
Sheikh, Ahsan M.	160 Cypress Point Parkway, Suite C210	Palm Coast	FL	32164	(386) 597-2825
Staples, Charles Keith	1775 Massey Road	Alabaster	AL	35007	(205) 601-7352
Stelser, Fernando J.	4 Oak Grove Avenue	Bath	ME	04530	(978) 771-7991
Stuchiner, Tamir	4904 Gable Ridge Drive	Durham	NC	27713	(919) 544-1751
Tapia, Fernando	103 Exchange Place	Pomona	CA	91768	(562) 522-6925
Taskaynatan, Murat	743 Main Street	Winchester	MA	01890	(781) 729-8844
Taylor, Robert III	P.O. Box 1747	West Chester	PA	19380	(610) 296-0200
Teel, Danny Keith	P.O. Box 2637	Kill Devil Hills	NC	27948	(252) 441-1525
Todd, Virgil L.	2642 West 21st Street	Yuma	AZ	85364	(928) 342-9798
Treacy, Edward W. III	11717 Old National Pike #18	New Market	MD	21774	(301) 865-1208
Turner, D. Craig	1045 N. Wilson Way	Stockton	CA	95205	(209) 299-7171
Vandenberg, Bruce M.	P.O. Box 860	North Bend	WA	98045	(541) 505-7478
Verlander, Garry A.	44569 W. Copper Trail	Maricopa	AZ	85139	(702) 326-8757
Vickers, Chad	915 Elder Road, Apartment 1N	Homewood	IL	60430	(347) 392-8030
Wilde, Bruce A.	153 Norwood Avenue	Norwalk	OH	44857	(419) 668-2766
Williams, Craig K.	5446 N Academy Boulevard #200	Colorado Springs	CO	80918	(719) 594-8900
Yildirim, Molly Hilal	1441 Mill Road	Lena	MS	39094	(601) 316-2040
Zadeh, Jeff	130 Ewald Avenue	Marlborough	MA	01752	(508) 481-5335
Zaidi, Syed Akhtar	24- Chain 'O' Hills Road	Iselin	NJ	08830	(973) 691-8900
Zebib, Mohammad A.	607 SW 11th Court	Palm City	FL	34990	(772) 879-2856

This list includes franchisees of outlets that were terminated, not renewed, transferred or otherwise left the system. Certain of these franchisees continue to operate other outlets under franchise agreements with us.

If you buy this franchise, your contact information may be disclosed to other buyers when you leave the franchise system.

EXHIBIT C

**DOMINO'S PIZZA FRANCHISING LLC
FINANCIAL STATEMENTS**

Domino's Pizza Franchising LLC and Subsidiary

**Consolidated Financial Statements
December 31, 2023 and January 1, 2023**



Report of Independent Auditors

To the Board of Managers of Domino's Pizza Franchising LLC

Opinion

We have audited the accompanying consolidated financial statements of Domino's Pizza Franchising LLC and its subsidiary (the "Company"), which comprise the consolidated balance sheets as of December 31, 2023 and January 1, 2023, and the related consolidated statements of income, of member's interest and of cash flows for the three years ended December 31, 2023, including the related notes (collectively referred to as the "consolidated financial statements").

In our opinion, the accompanying consolidated financial statements present fairly, in all material respects, the financial position of the Company as of December 31, 2023 and January 1, 2023, and the results of its operations and its cash flows for the three years ended December 31, 2023 in accordance with accounting principles generally accepted in the United States of America.

Basis for Opinion

We conducted our audit in accordance with auditing standards generally accepted in the United States of America (US GAAS). Our responsibilities under those standards are further described in the Auditors' Responsibilities for the Audit of the Consolidated Financial Statements section of our report. We are required to be independent of the Company and to meet our other ethical responsibilities, in accordance with the relevant ethical requirements relating to our audit. We believe that the audit evidence we have obtained is sufficient and appropriate to provide a basis for our audit opinion.

Responsibilities of Management for the Consolidated Financial Statements

Management is responsible for the preparation and fair presentation of the consolidated financial statements in accordance with accounting principles generally accepted in the United States of America, and for the design, implementation, and maintenance of internal control relevant to the preparation and fair presentation of consolidated financial statements that are free from material misstatement, whether due to fraud or error.

In preparing the financial statements, management is required to evaluate whether there are conditions or events, considered in the aggregate, that raise substantial doubt about the Company's ability to continue as a going concern for one year after the date the financial statements are available to be issued.

Auditors' Responsibilities for the Audit of the Consolidated Financial Statements

Our objectives are to obtain reasonable assurance about whether the financial statements as a whole are free from material misstatement, whether due to fraud or error, and to issue an auditors' report that includes our opinion. Reasonable assurance is a high level of assurance but is not absolute assurance and therefore is not a guarantee that an audit conducted in accordance with US GAAS will always detect a material misstatement when it exists. The risk of not detecting a material misstatement resulting from fraud is higher than for one resulting from error, as fraud may involve collusion, forgery, intentional omissions, misrepresentations, or the override of internal control. Misstatements are considered material if there is a substantial likelihood that, individually or in the aggregate, they would influence the judgment made by a reasonable user based on the financial statements.



In performing an audit in accordance with US GAAS, we:

- Exercise professional judgment and maintain professional skepticism throughout the audit.
- Identify and assess the risks of material misstatement of the consolidated financial statements, whether due to fraud or error, and design and perform audit procedures responsive to those risks. Such procedures include examining, on a test basis, evidence regarding the amounts and disclosures in the financial statements.
- Obtain an understanding of internal control relevant to the audit in order to design audit procedures that are appropriate in the circumstances, but not for the purpose of expressing an opinion on the effectiveness of the Company's internal control. Accordingly, no such opinion is expressed.
- Evaluate the appropriateness of accounting policies used and the reasonableness of significant accounting estimates made by management, as well as evaluate the overall presentation of the consolidated financial statements.
- Conclude whether, in our judgment, there are conditions or events, considered in the aggregate, that raise substantial doubt about the Company's ability to continue as a going concern for a reasonable period of time.

We are required to communicate with those charged with governance regarding, among other matters, the planned scope and timing of the audit, significant audit findings, and certain internal control-related matters that we identified during the audit.

PricewaterhouseCoopers LLP

Detroit, Michigan
March 18, 2024

**DOMINO'S PIZZA FRANCHISING LLC AND SUBSIDIARY
CONSOLIDATED BALANCE SHEETS**

(In thousands)	<u>December 31, 2023</u>	<u>January 1, 2023</u>
Assets		
Current assets:		
Restricted cash and cash equivalents	\$ 16,102	\$ 1,749
Accounts receivable, net of reserves of \$21 in 2023 and \$22 in 2022	10,157	10,816
Accounts receivable from affiliated companies	2,979	2,275
Prepaid expenses and other	<u>15</u>	<u>57</u>
Total current assets	<u>29,253</u>	<u>14,897</u>
Property:		
Buildings	16,085	21,757
Construction in progress	<u>—</u>	<u>51</u>
	16,085	21,808
Accumulated depreciation	<u>(12,615)</u>	<u>(16,677)</u>
Property, net	<u>3,470</u>	<u>5,131</u>
Other assets:		
Notes receivable	<u>783</u>	<u>783</u>
Total assets	<u>\$ 33,506</u>	<u>\$ 20,811</u>
Liabilities and member's interest		
Current liabilities:		
Accounts payable and other accrued liabilities	\$ 163	\$ 199
Accounts payable to affiliated companies	<u>69</u>	<u>—</u>
Total current liabilities	<u>232</u>	<u>199</u>
Member's interest:		
Member's interest	<u>33,274</u>	<u>20,612</u>
Total liabilities and member's interest	<u>\$ 33,506</u>	<u>\$ 20,811</u>

The accompanying notes are an integral part of these consolidated financial statements.

DOMINO'S PIZZA FRANCHISING LLC AND SUBSIDIARY
CONSOLIDATED STATEMENTS OF INCOME

(In thousands)	For the Years Ended		
	December 31, 2023	January 1, 2023	January 2, 2022
Revenues:			
Franchise royalties and fees	\$ 463,263	\$ 444,494	\$ 435,314
Total revenues	463,263	444,494	435,314
Operating expenses:			
Depreciation and amortization	656	711	707
Management fee (Note 4)	22,421	30,452	31,337
Gain on disposal of assets	(13,548)	—	—
Other	640	539	396
Total operating expenses	10,169	31,702	32,440
Income from operations	453,094	412,792	402,874
Interest income (expense), net	193	17	(1)
Income before provision for income taxes	453,287	412,809	402,873
Provision for income taxes	415	406	412
Net income	\$ 452,872	\$ 412,403	\$ 402,461

The accompanying notes are an integral part of these consolidated financial statements.

**DOMINO'S PIZZA FRANCHISING LLC AND SUBSIDIARY
CONSOLIDATED STATEMENTS OF MEMBER'S INTEREST**

(In thousands)	<u>Member's Interest</u>
Balance at January 3, 2021	\$ 22,538
Net income	402,461
Distributions (Note 4)	<u>(403,251)</u>
Balance at January 2, 2022	21,748
Net income	412,403
Capital contribution (Note 4)	500
Distributions (Note 4)	<u>(414,039)</u>
Balance at January 1, 2023	20,612
Net income	452,872
Distributions (Note 4)	<u>(440,210)</u>
Balance at December 31, 2023	<u><u>\$ 33,274</u></u>

The accompanying notes are an integral part of these consolidated financial statements.

DOMINO'S PIZZA FRANCHISING LLC AND SUBSIDIARY
CONSOLIDATED STATEMENTS OF CASH FLOWS

(In thousands)	For the Years Ended		
	December 31, 2023	January 1, 2023	January 2, 2022
Cash flows from operating activities:			
Net income	\$ 452,872	\$ 412,403	\$ 402,461
Adjustments to reconcile net income to net cash provided by operating activities:			
Depreciation and amortization	656	711	707
Gain on disposal of assets	(13,548)	—	—
Provision for losses on accounts and notes receivable	10	4	22
Changes in operating assets and liabilities:			
Accounts receivable	(55)	(1,520)	(412)
Accounts payable, accrued liabilities and other	76	(42)	(260)
Net cash provided by operating activities	440,011	411,556	402,518
Cash flows from investing activities:			
Capital expenditures	(346)	(324)	(1,198)
Proceeds from sale of assets	14,898	—	—
(Issuance) repayments of notes receivable	—	(20)	26
Net cash used in investing activities	14,552	(344)	(1,172)
Cash flows from financing activities:			
Distributions (Note 4)	(440,210)	(414,039)	(403,251)
Net cash used in financing activities	(440,210)	(414,039)	(403,251)
Change in restricted cash and cash equivalents	14,353	(2,827)	(1,905)
Restricted cash and cash equivalents, beginning of period	1,749	4,576	6,481
Restricted cash and cash equivalents, end of period	\$ 16,102	\$ 1,749	\$ 4,576

The accompanying notes are an integral part of these consolidated financial statements.

DOMINO'S PIZZA FRANCHISING LLC AND SUBSIDIARY
NOTES TO CONSOLIDATED FINANCIAL STATEMENTS

(1) Description of Business and Summary of Significant Accounting Policies

Description of Business

Domino's Pizza Franchising LLC (the "Company") is a single member Delaware limited liability company and is a wholly-owned subsidiary of Domino's Pizza Master Issuer LLC (the "Parent"), whose ultimate parent is Domino's Pizza, Inc. ("DPI"). The Company commenced operations on April 17, 2007. The Company is primarily engaged in franchising certain Domino's Pizza stores in the United States, and to a lesser extent, Puerto Rico, Guam and the U.S. Virgin Islands (collectively, the "American Territories" and collectively with the Domino's Pizza stores in the United States, the "Domestic Territories"). Revenues are derived from the receipt of royalties and, to a lesser extent, franchise and related fees from Domino's Pizza stores in the Domestic Territories.

Principles of Consolidation

The accompanying consolidated financial statements include the accounts of the Company and its subsidiary. All significant intercompany accounts and transactions have been eliminated.

Fiscal Year

The Company's fiscal year ends on the Sunday closest to December 31. The 2023 fiscal year ended on December 31, 2023, the 2022 fiscal year ended on January 1, 2023 and the 2021 fiscal year ended on January 2, 2022. The 2023, 2022 and 2021 fiscal years each consisted of fifty-two weeks.

Restricted Cash and Cash Equivalents

Cash equivalents consist of highly liquid investments with original maturities of three months or less at the date of purchase. These investments are carried at cost, which approximates fair value. The restricted cash and cash equivalents balance was \$16.1 million in 2023 and \$1.7 million in 2022. All cash and cash equivalents are restricted under the terms of the Parent's debt agreements (Note 3).

Accounts Receivable / Accounts Payable with Affiliated Companies

Accounts receivable from affiliated companies represent amounts owed to the Company by other subsidiaries of DPI. Accounts payable to affiliated companies represent amounts due to subsidiaries of DPI by the Company.

Allowances for Credit Losses

The Company closely monitors accounts and notes receivable balances and estimates the allowance for credit losses. These estimates are based on historical collection experience and other factors, including those related to current market conditions and events. The Company's allowances for accounts and notes receivable have not historically been material.

Property

Additions to property are recorded at cost. Depreciation and amortization expense for financial reporting purposes is recorded using the straight-line method over the estimated useful lives of the related assets. The estimated useful life for buildings is generally 20 years.

Revenue Recognition

Franchise royalties and fees are primarily comprised of royalties and fees from Domino's Pizza franchisees with operations in the Domestic Territories. Each franchisee is generally required to pay a 5.5% royalty fee on sales. In certain instances, the Company will collect lower rates based on area development agreements, sales initiatives, store relocation incentives and new store incentives. Royalty revenues are based on a percentage of franchise retail sales and are recognized when the items are delivered to or carried out by franchisees' customers. Payments for royalties and fees from U.S. franchisees are generally due within seven days of the prior week end date and payments for royalties and fees from franchisees in the American Territories are due at least monthly.

Disaggregation of Revenue

Current accounting standards require that companies disaggregate revenue from contracts with customers into categories that depict how the nature, amount, timing, and uncertainty of revenue and cash flows are affected by economic factors. \$1.8 million of the Company's royalties and fees revenues were derived from the American Territories in each of 2023, 2022 and 2021.

Fair Value Measurements

Fair value measurements enable the reader of the consolidated financial statements to assess the inputs used to develop those measurements by establishing a hierarchy for ranking the quality and reliability of the information used to determine fair values. The Company classifies and discloses assets and liabilities carried at fair value in one of the following three categories:

Level 1: Quoted market prices in active markets for identical assets or liabilities.

Level 2: Observable market-based inputs or unobservable inputs that are corroborated by market data.

Level 3: Unobservable inputs that are not corroborated by market data.

The fair values of the Company's restricted cash equivalents are based on quoted prices in active markets for identical assets.

The following table summarizes the carrying amounts and fair values of the Company's restricted cash equivalents at December 31, 2023 and January 1, 2023 (in thousands):

	Carrying Amount	At December 31, 2023		
		Fair Value Estimated Using		
		Level 1 Inputs	Level 2 Inputs	Level 3 Inputs
Restricted cash equivalents	\$ 14,355	\$ 14,355	\$ —	\$ —

	Carrying Amount	At January 1, 2023		
		Fair Value Estimated Using		
		Level 1 Inputs	Level 2 Inputs	Level 3 Inputs
Restricted cash equivalents	\$ 3	\$ 3	\$ —	\$ —

Use of Estimates

The preparation of financial statements in conformity with accounting principles generally accepted in the United States requires management to make estimates and assumptions that affect the reported amounts of assets and liabilities and disclosures of contingent assets and liabilities at the date of the financial statements and the reported amounts of revenues and expenses during the reporting period. Actual results could differ from those estimates.

New Accounting Pronouncements

The Company has considered all new accounting pronouncements issued by the Financial Accounting Standards Board. There are no accounting pronouncements issued that are expected to have a material impact on the Company's consolidated financial statements.

Subsequent Events

The Company evaluated subsequent events occurring after December 31, 2023 through the date the consolidated financial statements were available to be issued on March 18, 2024. Based on this evaluation, the Company determined there were no subsequent events that required recognition or disclosure.

(2) Taxation

The Company is a single member limited liability company and is treated as a disregarded entity for federal and state income tax purposes and therefore does not record an allocation of income taxes paid by the Parent in its consolidated financial statements. The provision for taxes reflected in these consolidated statements primarily represents non-resident withholding taxes incurred by the Company. The Company recorded total non-resident withholding tax expense of \$0.4 million in each of 2023, 2022 and 2021.

As required by authoritative accounting guidance, the Company recognizes the financial statement benefit of a tax position only after determining that the relevant tax authority would more likely than not sustain the position following an audit. For tax positions meeting the “more likely than not” threshold, the amount recognized in the consolidated financial statements is the largest benefit that has a greater than 50 percent likelihood of being realized upon ultimate settlement with the relevant tax authority.

(3) DPI Recapitalizations and Company Guarantees of Related Debt Obligations

DPI has completed recapitalization transactions in 2021, 2019, 2018, 2017 and 2015. As noted below with respect to guarantees and covenants of the notes, the Company has, along with certain other affiliates, guaranteed the interest and principal obligations of the Notes. The 2021 Notes, 2019 Notes, 2018 Notes, 2017 Notes and 2015 Notes (each, as defined below) are collectively referred to as the “Notes.”

2021 Recapitalization

On April 16, 2021, DPI completed a recapitalization (the “2021 Recapitalization”) in which certain of DPI’s subsidiaries issued notes pursuant to an asset-backed securitization. The notes consist of \$850.0 million Series 2021-1 2.662% Fixed Rate Senior Secured Notes, Class A-2-I with an anticipated term of 7.5 years (the “2021 7.5-Year Notes”) and \$1.0 billion Series 2021-1 3.151% Fixed Rate Senior Secured Notes, Class A-2-II with an anticipated term of 10 years (the “2021 Ten-Year Notes”, and, collectively with the 2021 7.5-Year Notes, the “2021 Notes”). Gross proceeds from the issuance of the 2021 Notes were \$1.85 billion. A portion of the proceeds from the 2021 Recapitalization were used to repay the remaining \$291.0 million in outstanding principal under DPI’s 2017 Floating Rate Notes and \$582.0 million in outstanding principal under DPI’s 2017 Five-Year Notes, prefund a portion of the interest payable on the 2021 Notes and pay transaction fees and expenses.

Concurrently, certain of DPI’s subsidiaries also issued a variable funding note facility which allows for advances of up to \$200.0 million of Series 2021-1 Variable Funding Senior Secured Notes, Class A-1 Notes and certain other credit instruments, including letters of credit (the “2021 Variable Funding Notes”). On May 15, 2023, certain of DPI’s subsidiaries executed an amendment to DPI’s 2021 Variable Funding Notes to affect the transition from LIBOR to Secured Overnight Financing Rate, plus a spread adjustment (“Adjusted Term SOFR”). Certain clarifying amendments were effectuated on September 19, 2023. The interest rate on the 2021 Variable Funding Notes is payable at a per year rate equal to Adjusted Term SOFR, plus 150 basis points.

As of December 31, 2023 and January 1, 2023, the Company had no outstanding borrowings and \$157.8 million of available borrowing capacity under its 2021 Variable Funding Notes, net of letters of credit issued of \$42.2 million.

2019 Recapitalization

On November 19, 2019, DPI completed a recapitalization (the “2019 Recapitalization”) in which certain of DPI’s subsidiaries issued \$675.0 million Series 2019-1 3.668% Fixed Rate Senior Secured Notes, Class A-2 with an anticipated term of 10 years (the “2019 Ten-Year Notes”) pursuant to an asset-backed securitization. Gross proceeds from the issuance of the 2019 Notes were \$675.0 million.

2018 Recapitalization

On April 24, 2018, DPI completed a recapitalization (the “2018 Recapitalization”) in which certain of DPI’s subsidiaries issued notes pursuant to an asset-backed securitization. The notes consist of \$425.0 million Series 2018-1 4.116% Fixed Rate Senior Secured Notes, Class A-2-I with an anticipated term of 7.5 years (the “2018 7.5-Year Notes”), and \$400.0 million Series 2018-1 4.328% Fixed Rate Senior Secured Notes, Class A-2-II with an anticipated term of 9.25 years (the “2018 9.25-Year Notes” and, collectively with the 2018 7.5-Year Notes, the “2018 Notes”). Gross proceeds from the issuance of the 2018 Notes were \$825.0 million.

2017 Recapitalization

On July 24, 2017, DPI completed a recapitalization (the “2017 Recapitalization”) in which certain of DPI’s subsidiaries issued notes pursuant to an asset-backed securitization. The notes consisted of \$300.0 million Series 2017-1 Floating Rate Senior Secured Notes, Class A-2-I with an anticipated term of five years (the “2017 Floating Rate Notes”), \$600.0 million Series 2017-1 3.082% Fixed Rate Senior Secured Notes, Class A-2-II with an anticipated term of five years (the “2017 Five-Year Notes”), and \$1.0 billion Series 2017-1 4.118% Fixed Rate Senior Secured Notes, Class A-2-III with an anticipated term of ten years (the “2017 Ten-Year Notes” and, collectively with the 2017 Floating Rate Notes and the 2017 Five-Year Notes, the “2017 Notes”). The interest rate on the 2017 Floating Rate Notes was payable at a rate equal to LIBOR plus 125 basis points. Gross proceeds from the issuance of the 2017 Notes were \$1.9 billion. The 2017 Floating Rate Notes and the 2017 Five-Year Notes were repaid in connection with the 2021 Recapitalization.

2015 Recapitalization

On October 21, 2015, DPI completed a recapitalization transaction (the “2015 Recapitalization”) in which certain of DPI’s subsidiaries issued new notes pursuant to an asset-backed securitization. The notes consisted of \$500.0 million Series 2015-1 3.484% Fixed Rate Senior Secured Notes, Class A-2-I (the “2015 Five-Year Notes”) and \$800.0 million Series 2015-1 4.474% Fixed Rate Senior Secured Notes, Class A-2-II (the “2015 Ten-Year Notes” and, together with the 2015 Five-Year Notes, the “2015 Notes”). Gross proceeds from the issuance of the 2015 Notes were \$1.3 billion. The 2015 Five-Year Notes were repaid in connection with the 2018 Recapitalization.

2022 Variable Funding Notes

On September 16, 2022, DPI issued a new variable funding note facility which allows for advances of up to \$120.0 million of Series 2022-1 Variable Funding Senior Secured Notes, Class A-1 Notes (the “2022 Variable Funding Notes”). The facility was undrawn at closing. Interest on the 2022 Variable Funding Notes is payable at a per year rate equal to Adjusted Term SOFR plus 150 basis points. The unused portion of the 2022 Variable Funding Notes is subject to a commitment fee of 50 basis points. It is anticipated that any amounts outstanding on the 2022 Variable Funding Notes will be repaid in full on or prior to April 2026, subject to two additional one-year extensions at the option of DPI, subject to certain conditions. Following the anticipated repayment date (and any extensions thereof), additional interest will accrue on the 2022 Variable Funding Notes equal to 5% per annum.

As of December 31, 2023 and January 1, 2023, DPI had no outstanding borrowings and \$120.0 million of available borrowing capacity under its 2022 Variable Funding Notes.

Guarantees and Covenants of the Notes

The Notes, the 2022 Variable Funding Notes and the 2021 Variable Funding Notes were issued by certain of DPI’s subsidiaries which hold substantially all of DPI’s revenue-generating assets, excluding DPI’s U.S. Company-owned stores. The Notes are guaranteed by certain of DPI’s subsidiaries and secured by a security interest in substantially all of the assets of the DPI’s subsidiaries, including royalty and certain other income from all U.S. and international stores, domestic supply chain income and intellectual property. The restrictions placed on certain of DPI’s subsidiaries require that the principal and interest obligations have first priority and amounts are segregated weekly to ensure appropriate funds are reserved to pay the quarterly principal and interest amounts due. The amount of weekly cash flow that exceeds the required weekly principal and interest reserve is generally remitted to the Parent in the form of a dividend. However, once the required obligations are satisfied, there are no further restrictions, including payment of dividends, on the cash flows of the subsidiaries. The Company has, along with certain other affiliates, guaranteed the interest and principal obligations of the Notes.

The Notes are subject to certain financial and non-financial covenants, including a debt service coverage ratio calculation. The covenant requires a minimum coverage ratio of 1.75x total debt service to securitized net cash flow, as defined in the related agreements. The covenants, among other things, may limit the ability of the Company and its subsidiary to declare dividends, make loans or advances or enter into transactions with affiliates. In the event that certain covenants are not met, the Notes may become partially or fully due and payable on an accelerated schedule. In addition, DPI may voluntarily prepay, in part or in full, the Notes at any time, subject to certain make-whole interest obligations.

(4) Related Party Transactions

Distributions

The Company is required to distribute its excess cash flows to the Parent pursuant to an operating agreement with the Parent. The Parent uses the funds distributed to it by the Company to, among other things, service its debt obligations. The Company distributed \$440.2 million, \$414.0 million and \$403.3 million in 2023, 2022 and 2021, respectively, pursuant to this operating agreement.

Management Fee

The Parent and certain of its subsidiaries have a management agreement with Domino's Pizza LLC, a subsidiary of DPI, (the "Manager") whereby the Manager will service new and existing franchise agreements, certain intellectual property and distribution assets for the Domino's Pizza system.

In fiscal 2021 and 2022 prior to September 16, 2022 upon issuance of the 2022 Variable Funding Notes, the Parent and certain of its subsidiaries were obligated to pay a total annual fee to the Manager in an amount equal to the sum of (i) \$26.5 million, (ii) \$600,000 for every 100 Domino's Pizza stores open in the contiguous United States, and (iii) a 2% increase as of each anniversary of the initial closing date of the Parent's March 16, 2012 recapitalization transaction. As of September 16, 2022, the Parent and certain of its subsidiaries were obligated to pay a total annual fee to the Manager in an amount equal to the sum of (i) \$14.0 million and (ii) \$4.7 thousand for every integer multiple of \$100.0 thousand in aggregate Retained Collections (excluding PULSE Maintenance Fees and Technology Fees), as defined in the related agreements. The Company's portion of the management fee was allocated based on its percentage of earnings before interest, taxes, depreciation and amortization and other, referred to as Segment Income, in comparison to the other subsidiaries of the Parent. Management believes this allocation method to be reasonable. Of the total required management fee, the Company expensed approximately \$22.4 million, \$30.5 million, and \$31.3 million for this Management Fee in 2023, 2022 and 2021, respectively.

Additionally, the management fee includes reimbursement of an allocation of certain operating expenses incurred by the Manager. The allocation of these expenses was based on a review of the historical relationships of the amounts and types of expenses incurred by the Manager.

Capital Contributions and Return of Capital

In 2022, the Company recorded a non-cash capital contribution of \$0.5 million associated with the issuance a note receivable in connection with the Parent's refranchising of certain assets to a franchisee.

(5) Purchase and Sale Agreement

In the fourth quarter of 2023, a subsidiary of the Company entered into a purchase and sale agreement with a developer to sell one of the Company's owned supply chain center buildings and the associated land for \$14.9 million. The Company recognized a gain on the disposal of the related assets of \$13.5 million.

EXHIBIT D

**DOMINO'S PIZZA LLC
FINANCIAL STATEMENTS**

Domino's Pizza LLC and Subsidiaries

**Consolidated Financial Statements
December 31, 2023 and January 1, 2023**



Report of Independent Auditors

To the Board of Managers of Domino's Pizza LLC

Opinion

We have audited the accompanying consolidated financial statements of Domino's Pizza LLC and its subsidiaries (the "Company"), which comprise the consolidated balance sheets as of December 31, 2023 and January 1, 2023, and the related consolidated statements of income and comprehensive income, of member's deficit and of cash flows for the three years ended December 31, 2023, including the related notes (collectively referred to as the "financial statements").

In our opinion, the accompanying consolidated financial statements present fairly, in all material respects, the financial position of the Company as of December 31, 2023 and January 1, 2023, and the results of its operations and its cash flows for the three years ended January 1, 2023 in accordance with accounting principles generally accepted in the United States of America.

Basis for Opinion

We conducted our audit in accordance with auditing standards generally accepted in the United States of America (US GAAS). Our responsibilities under those standards are further described in the Auditors' Responsibilities for the Audit of the Consolidated Financial Statements section of our report. We are required to be independent of the Company and to meet our other ethical responsibilities, in accordance with the relevant ethical requirements relating to our audit. We believe that the audit evidence we have obtained is sufficient and appropriate to provide a basis for our audit opinion.

Responsibilities of Management for the Consolidated Financial Statements

Management is responsible for the preparation and fair presentation of the consolidated financial statements in accordance with accounting principles generally accepted in the United States of America, and for the design, implementation, and maintenance of internal control relevant to the preparation and fair presentation of consolidated financial statements that are free from material misstatement, whether due to fraud or error.

In preparing the financial statements, management is required to evaluate whether there are conditions or events, considered in the aggregate, that raise substantial doubt about the Company's ability to continue as a going concern for one year after the date the financial statements are available to be issued.

Auditors' Responsibilities for the Audit of the Consolidated Financial Statements

Our objectives are to obtain reasonable assurance about whether the financial statements as a whole are free from material misstatement, whether due to fraud or error, and to issue an auditors' report that includes our opinion. Reasonable assurance is a high level of assurance but is not absolute assurance and therefore is not a guarantee that an audit conducted in accordance with US GAAS will always detect a material misstatement when it exists. The risk of not detecting a material misstatement resulting from fraud is higher than for one resulting from error, as fraud may involve collusion, forgery, intentional omissions, misrepresentations, or the override of internal control. Misstatements are considered material if there is a substantial likelihood that, individually or in the aggregate, they would influence the judgment made by a reasonable user based on the financial statements.



In performing an audit in accordance with US GAAS, we:

- Exercise professional judgment and maintain professional skepticism throughout the audit.
- Identify and assess the risks of material misstatement of the consolidated financial statements, whether due to fraud or error, and design and perform audit procedures responsive to those risks. Such procedures include examining, on a test basis, evidence regarding the amounts and disclosures in the financial statements.
- Obtain an understanding of internal control relevant to the audit in order to design audit procedures that are appropriate in the circumstances, but not for the purpose of expressing an opinion on the effectiveness of the Company's internal control. Accordingly, no such opinion is expressed.
- Evaluate the appropriateness of accounting policies used and the reasonableness of significant accounting estimates made by management, as well as evaluate the overall presentation of the consolidated financial statements.
- Conclude whether, in our judgment, there are conditions or events, considered in the aggregate, that raise substantial doubt about the Company's ability to continue as a going concern for a reasonable period of time.

We are required to communicate with those charged with governance regarding, among other matters, the planned scope and timing of the audit, significant audit findings, and certain internal control-related matters that we identified during the audit.

PricewaterhouseCoopers LLP

Detroit, Michigan
March 18, 2024

Domino's Pizza LLC and Subsidiaries
CONSOLIDATED BALANCE SHEETS
(In thousands, except share and per share amounts)

	December 31, 2023	January 1, 2023
<u>Assets</u>		
Current assets:		
Cash and cash equivalents	\$ 114,098	\$ 60,350
Restricted cash and cash equivalents	200,870	191,289
Accounts receivable, net of reserves of \$5,885 in 2023 and \$4,762 in 2022	282,809	257,498
Inventories	82,964	81,570
Prepaid expenses and other	30,215	37,287
Advertising fund assets, restricted	106,335	162,660
Total current assets	817,291	790,654
Property, plant and equipment:		
Land and buildings	108,791	105,659
Leasehold and other improvements	176,817	172,725
Equipment	364,620	333,787
Construction in progress	24,505	22,536
	674,733	634,707
Accumulated depreciation and amortization	(370,368)	(332,472)
Property, plant and equipment, net	304,365	302,235
Other assets:		
Operating lease right-of-use assets	207,323	219,202
Investments in marketable securities, restricted	16,720	13,395
Goodwill	11,688	11,763
Capitalized software, net of accumulated amortization of \$183,980 in 2023 and \$165,457 in 2022	134,105	108,354
Investments	143,553	125,840
Other assets	26,174	28,852
Deferred income tax assets, net	13,680	1,926
Total other assets	553,243	509,332
Total assets	\$ 1,674,899	\$ 1,602,221
<u>Liabilities and member's deficit</u>		
Current liabilities:		
Current portion of long-term debt	\$ 56,366	\$ 54,813
Accounts payable	106,267	89,715
Accrued compensation	54,689	40,442
Accrued interest	33,367	34,473
Operating lease liabilities	39,330	34,877
Insurance reserves	28,135	31,435
Advertising fund liabilities	104,246	157,909
Other accrued liabilities	124,950	92,957
Total current liabilities	547,350	536,621
Long-term liabilities:		
Long-term debt, less current portion	4,934,062	4,967,420
Operating lease liabilities	179,548	195,244
Insurance reserves	38,559	40,179
Deferred income tax liabilities	-	7,761
Other accrued liabilities	45,747	44,061
Total long-term liabilities	5,197,916	5,254,665
Total liabilities	5,745,266	5,791,286
Commitments and contingencies (Note 5)		
Member's deficit		
Class A common stock, par value \$0.05 per share; 2,000,000 shares authorized; 1,406,778 shares issued and outstanding	70	70
Class B common stock, par value \$0.01 per share; 50,000 shares authorized; no shares issued and outstanding	—	—
Member's deficit	(4,066,570)	(4,184,441)
Accumulated other comprehensive loss	(3,867)	(4,694)
Total member's deficit	(4,070,367)	(4,189,065)
Total liabilities and member's deficit	\$ 1,674,899	\$ 1,602,221

The accompanying notes are an integral part of these consolidated financial statements.

Domino's Pizza LLC and Subsidiaries
CONSOLIDATED STATEMENTS OF INCOME
(In thousands)

	For the Years Ended		
	December 31, 2023	January 1, 2023	January 2, 2022
Revenues:			
U.S. Company-owned stores	\$ 376,180	\$ 445,810	\$ 478,976
U.S. franchise royalties and fees	604,897	556,269	539,883
Supply chain	2,715,009	2,754,742	2,560,977
International franchise royalties and fees	310,077	295,007	298,036
U.S. franchise advertising	473,195	485,330	479,501
Total revenues	<u>4,479,358</u>	<u>4,537,158</u>	<u>4,357,373</u>
Cost of sales:			
U.S. Company-owned stores	314,673	378,018	374,104
Supply chain	2,437,268	2,510,534	2,295,027
Total cost of sales	<u>2,751,941</u>	<u>2,888,552</u>	<u>2,669,131</u>
Gross margin	<u>1,727,417</u>	<u>1,648,606</u>	<u>1,688,242</u>
General and administrative	434,554	416,524	428,333
U.S. franchise advertising	473,195	485,330	479,501
Refranchising loss (gain)	149	(21,173)	—
Income from operations	<u>819,519</u>	<u>767,925</u>	<u>780,408</u>
Other income	17,713	—	36,758
Interest income	11,683	3,162	345
Interest expense	(196,475)	(198,254)	(191,806)
Income before provision for income taxes	<u>652,440</u>	<u>572,833</u>	<u>625,705</u>
Provision for income taxes	<u>133,322</u>	<u>120,570</u>	<u>115,238</u>
Net income	<u>\$ 519,118</u>	<u>\$ 452,263</u>	<u>\$ 510,467</u>

The accompanying notes are an integral part of these consolidated financial statements.

Domino's Pizza LLC and Subsidiaries
CONSOLIDATED STATEMENTS OF COMPREHENSIVE INCOME
(In thousands)

	For the Years Ended		
	December 31, 2023	January 1, 2023	January 2, 2022
Net income	\$ 519,118	\$ 452,263	\$ 510,467
Currency translation adjustment	827	(1,874)	(396)
Comprehensive income	\$ 519,945	\$ 450,389	\$ 510,071

The accompanying notes are an integral part of these consolidated financial statements.

Domino's Pizza LLC and Subsidiaries
CONSOLIDATED STATEMENTS OF MEMBER'S DEFICIT
(In thousands, except share amounts)

	Class A		Class B		Member's Deficit	Accumulated Other Comprehensive Income (Loss)
	Common Stock		Common Stock			
	Shares	Amount	Shares	Amount		
Balance at January 3, 2021	1,406,778	\$ 70	—	\$ —	\$ (3,298,051)	\$ (2,424)
Net income	—	—	—	—	510,467	—
Contributions	—	—	—	—	19,682	—
Distributions	—	—	—	—	(1,467,121)	—
Non-cash Parent equity-based compensation expense	—	—	—	—	28,670	—
Other	—	—	—	—	(433)	—
Currency translation adjustment	—	—	—	—	—	(396)
Balance at January 2, 2022	1,406,778	70	—	—	(4,206,786)	(2,820)
Net income	—	—	—	—	452,263	—
Contributions	—	—	—	—	3,312	—
Distributions	—	—	—	—	(461,991)	—
Non-cash Parent equity-based compensation expense	—	—	—	—	28,709	—
Other	—	—	—	—	52	—
Currency translation adjustment	—	—	—	—	—	(1,874)
Balance at January 1, 2023	1,406,778	70	—	—	(4,184,441)	(4,694)
Net income	—	—	—	—	519,118	—
Contributions	—	—	—	—	8,656	—
Distributions	—	—	—	—	(444,207)	—
Non-cash Parent equity-based compensation expense	—	—	—	—	37,514	—
Other	—	—	—	—	(3,210)	—
Currency translation adjustment	—	—	—	—	—	827
Balance at December 31, 2023	<u>1,406,778</u>	<u>\$ 70</u>	<u>—</u>	<u>\$ —</u>	<u>\$ (4,066,570)</u>	<u>\$ (3,867)</u>

The accompanying notes are an integral part of these consolidated financial statements.

Domino's Pizza LLC and Subsidiaries
CONSOLIDATED STATEMENTS OF CASH FLOWS
(In thousands)

	For the Years Ended		
	December 31, 2023	January 1, 2023	January 2, 2022
Cash flows from operating activities:			
Net income	\$ 519,118	\$ 452,263	\$ 510,467
Adjustments to reconcile net income to net cash provided by operating activities:			
Depreciation and amortization	80,640	80,251	72,923
Refranchising loss (gain)	149	(21,173)	—
Loss on sale/disposal of assets	1,299	1,813	1,189
Amortization of debt issuance costs	5,535	5,645	7,509
(Benefit) provision for deferred income taxes	(19,509)	253	1,988
Non-cash Parent equity-based compensation expense	37,514	28,709	28,670
Excess tax benefits from Parent equity-based compensation	(3,397)	(2,169)	(18,911)
Provision for losses on accounts and notes receivable	1,472	3,536	659
Unrealized gain on investments	(17,713)	—	(36,758)
Changes in operating assets and liabilities:			
Changes in accounts receivable	(26,515)	(6,333)	(8,107)
Changes in inventories, prepaid expenses and other	160	(17,059)	(9,420)
Changes in accounts payable and accrued liabilities	69,373	(36,605)	51,346
Changes in insurance reserves	(5,163)	1,507	6,216
Changes in operating lease assets and liabilities	632	2,174	1,210
Changes in advertising fund assets and liabilities, restricted	(52,731)	(17,495)	45,225
Net cash provided by operating activities	<u>590,864</u>	<u>475,317</u>	<u>654,206</u>
Cash flows from investing activities:			
Capital expenditures	(105,396)	(87,234)	(94,172)
Proceeds from sale of assets	161	41,089	16
Purchases of franchise operations and other assets	—	(6,814)	—
Purchase of investments	—	—	(49,082)
Other	(1,682)	(722)	515
Net cash used in investing activities	<u>(106,917)</u>	<u>(53,681)</u>	<u>(142,723)</u>
Cash flows from financing activities:			
Proceeds from issuance of long-term debt	14,898	120,000	1,850,000
Repayments of long-term debt and finance lease obligations	(55,705)	(175,676)	(910,212)
Cash paid for financing costs	—	(1,594)	(14,938)
Distributions	(444,207)	(461,991)	(1,467,121)
Contributions	8,662	3,312	19,682
Other	—	—	(244)
Net cash used in financing activities	<u>(476,352)</u>	<u>(515,949)</u>	<u>(522,833)</u>
Effect of exchange rate changes on cash	340	(963)	(316)
Change in cash and cash equivalents, restricted cash and cash equivalents	<u>7,935</u>	<u>(95,276)</u>	<u>(11,666)</u>
Cash and cash equivalents, beginning of period	60,350	148,154	168,815
Restricted cash and cash equivalents, beginning of period	191,289	180,579	217,453
Cash and cash equivalents included in advertising fund assets, restricted, beginning of period	<u>143,559</u>	<u>161,741</u>	<u>115,872</u>
Cash and cash equivalents, restricted cash and cash equivalents and cash and cash equivalents included in advertising fund assets, restricted, beginning of period	<u>395,198</u>	<u>490,474</u>	<u>502,140</u>
Cash and cash equivalents, end of period	114,098	60,350	148,154
Restricted cash and cash equivalents, end of period	200,870	191,289	180,579
Cash and cash equivalents included in advertising fund assets, restricted, end of period	<u>88,165</u>	<u>143,559</u>	<u>161,741</u>
Cash and cash equivalents, restricted cash and cash equivalents and cash and cash equivalents included in advertising fund assets, restricted, end of period	<u>\$ 403,133</u>	<u>\$ 395,198</u>	<u>\$ 490,474</u>

The accompanying notes are an integral part of these consolidated financial statements.

Domino's Pizza LLC and Subsidiaries
NOTES TO CONSOLIDATED FINANCIAL STATEMENTS
(Tabular amounts in thousands, except percentages, share and per share amounts)

(1) Description of Business and Summary of Significant Accounting Policies

Description of Business

Domino's Pizza LLC ("DPLLC"), a Michigan limited liability company, is a wholly-owned subsidiary of Domino's, Inc. ("Domino's"). Domino's is the wholly-owned subsidiary of Domino's Pizza, Inc. (the "Parent"). DPLLC and its wholly-owned subsidiaries (collectively, the "Company") are primarily engaged in the following business activities: (i) retail sales of food through Company-owned Domino's Pizza stores; (ii) sales of food, equipment and supplies to franchised Domino's Pizza stores through Company-owned supply chain centers in the U.S. and Canada; (iii) receipt of royalties, advertising contributions and fees from U.S. Domino's Pizza franchisees; and (iv) receipt of royalties and fees from international Domino's Pizza franchisees.

Principles of Consolidation

The accompanying consolidated financial statements include the accounts of DPLLC and its subsidiaries. All significant intercompany accounts and transactions have been eliminated.

Fiscal Year

The Company's fiscal year ends on the Sunday closest to December 31. The 2023 fiscal year ended on December 31, 2023, the 2022 fiscal year ended on January 1, 2023 and the 2021 fiscal year ended on January 2, 2022. The 2023, 2022 and 2021 fiscal years each consisted of fifty-two weeks.

Cash and Cash Equivalents

Cash equivalents consist of highly liquid investments with original maturities of three months or less at the date of purchase. These investments are carried at cost, which approximates fair value.

Restricted Cash and Cash Equivalents

Restricted cash and cash equivalents at December 31, 2023 included \$149.1 million of restricted cash and cash equivalents held for future principal and interest payments and other working capital requirements of the Company's asset-backed securitization structure, \$51.6 million of restricted cash equivalents held in a three-month interest reserve as required by the related debt agreements and \$0.2 million of other restricted cash. As of December 31, 2023, the Company also held \$88.2 million of advertising fund restricted cash and cash equivalents, which can only be used for activities that promote the Domino's Pizza brand.

Restricted cash and cash equivalents at January 1, 2023 included \$141.2 million of restricted cash and cash equivalents held for future principal and interest payments and other working capital requirements of the Company's asset-backed securitization structure, \$49.9 million of restricted cash equivalents held in a three-month interest reserve as required by the related debt agreements and \$0.2 million of other restricted cash. As of January 1, 2023, the Company also held \$143.6 million of advertising fund restricted cash and cash equivalents, which can only be used for activities that promote the Domino's Pizza brand.

Allowances for Credit Losses

The Company closely monitors accounts and notes receivable balances and estimates the allowance for credit losses. These estimates are based on historical collection experience and other factors, including those related to current market conditions and events. The Company's allowances for accounts and notes receivable have not historically been material.

The Company also monitors its off-balance sheet exposures under its letters of credit (Note 2), lease guarantees (Note 4) and surety bonds. Total conditional commitments under surety bonds were \$14.7 million in each of December 31, 2023 and January 1, 2023, respectively. None of these arrangements has had or is likely to have a material effect on the Company's results of operations, financial condition, revenues, expenses or liquidity.

Inventories

Inventories are valued at the lower of cost (on a first-in, first-out basis) or net realizable value. Inventories at December 31, 2023 and January 1, 2023 were comprised of the following:

	December 31, 2023	January 1, 2023
Food	\$ 72,525	\$ 74,052
Equipment and supplies	10,439	7,518
Inventories	<u>\$ 82,964</u>	<u>\$ 81,570</u>

Other Assets

Current and long-term other assets primarily include prepaid expenses such as insurance, taxes, deposits, notes receivable, software licenses, implementation costs for cloud-based computing arrangements, covenants not-to-compete and other intangible assets primarily arising from franchise acquisitions.

Other long-term assets included implementation costs for cloud-based computing arrangements (primarily related to certain enterprise systems) of \$11.1 million and \$11.9 million, net of accumulated amortization of \$6.2 million and \$3.5 million as of December 31, 2023 and January 1, 2023, respectively. Amortization expense for implementation costs for cloud-based computing arrangements was \$2.7 million, \$1.9 million and \$1.3 million in 2023, 2022 and 2021, respectively.

Property, Plant and Equipment

Additions to property, plant and equipment are recorded at cost. Repair and maintenance costs are expensed as incurred. Depreciation and amortization expense are recorded using the straight-line method over the estimated useful lives of the related assets. Estimated useful lives are generally as follows (in years):

Buildings	20
Leasehold and other improvements	5 – 15
Equipment	3 – 15

Depreciation and amortization expense on property, plant and equipment was \$52.4 million, \$51.8 million and \$48.6 million in 2023, 2022 and 2021, respectively.

Impairments of Long-Lived Assets

The Company evaluates the potential impairment of long-lived assets at least annually based on various analyses including, on an annual basis, the projection of undiscounted cash flows and whenever events or changes in circumstances indicate that the carrying amount of the assets may not be recoverable. If the Company determines that the carrying amount of an asset (or asset group) may not be recoverable, the Company compares the net carrying value of the asset group to the undiscounted net cash flows to be generated from the use and eventual disposition of that asset group. For Company-owned stores, the Company performs this evaluation on an operating market basis, which the Company has determined to be the lowest level for which identifiable cash flows are largely independent of other cash flows. If the carrying amount of a long-lived asset exceeds the amount of the expected future undiscounted cash flows of that asset, the Company estimates the fair value of the assets. If the carrying amount of the asset exceeds the estimated fair value of the asset, an impairment loss is recognized, and the asset is written down to its estimated fair value. There were no triggering events in 2023, 2022 and 2021 and accordingly, the Company did not record any impairment losses on long-lived assets in 2023, 2022 and 2021.

Investments in Marketable Securities

Investments in marketable securities consist of investments in various mutual funds made by eligible individuals as part of the Company's deferred compensation plan (Note 7). These investments are stated at aggregate fair value, are restricted and have been placed in a rabbi trust whereby the amounts are irrevocably set aside to fund the Company's obligations under the deferred compensation plan. The Company classifies and accounts for these investments in marketable securities as trading securities.

Goodwill

The Company's goodwill amounts primarily relate to franchise store acquisitions. The Company performs its required impairment tests in the fourth quarter of each fiscal year and did not recognize any goodwill impairment charges in 2023, 2022 and 2021.

Capitalized Software

Capitalized software is recorded at cost and includes purchased, internally-developed and externally-developed software used in the Company's operations. Amortization expense is provided using the straight-line method over the estimated useful lives of the software, which range from one to ten years. Capitalized software amortization expense was \$28.2 million, \$28.5 million and \$24.3 million in 2023, 2022 and 2021, respectively.

As of December 31, 2023, scheduled amortization for capitalized software that had been placed in service as of December 31, 2023 is as follows in the table below. As of December 31, 2023, the Company also had \$34.1 million of capitalized software that had not yet been placed in service.

2024	\$	26,737
2025		19,426
2026		12,635
2027		8,236
2028		8,236
Thereafter		24,702
	\$	<u>99,972</u>

Investment in DPC Dash

The Company holds a non-controlling interest in DPC Dash Ltd ("DPC Dash"), the Company's master franchisee in China that owns and operates Domino's Pizza stores in that market. Prior to March 28, 2023, the Company's investment in DPC Dash's senior ordinary shares, which were not in-substance common stock, represented an equity investment without a readily determinable fair value and was recorded at cost with adjustments for observable changes in prices resulting from orderly transactions for the identical or a similar investment of the same issuer or impairments.

On March 28, 2023, DPC Dash completed its initial public offering on the Hong Kong Exchange (HK: 1405), at which point the Company's 18,101,019 DPC Dash senior ordinary shares automatically converted to DPC Dash ordinary shares pursuant to the terms of the investment. The Company is required to hold the DPC Dash ordinary shares for at least 360 days from the date of the initial public offering of March 28, 2023. The Company accounts for its investment in DPC Dash as a trading security and records it at fair value at the end of each reporting period, with gains and losses recorded in other income or expense in its consolidated statements of income. Refer to Note 3 for fair value disclosures related to the Company's investment in DPC Dash.

Debt Issuance Costs

Debt issuance costs are recorded as a reduction to the Company's debt balance and primarily include the expenses incurred by the Company as part of the 2021, 2019, 2018, 2017 and 2015 Recapitalizations. Refer to Note 2 for a description of the 2021, 2019, 2018, 2017 and 2015 Recapitalizations. Amortization is recorded on a straight-line basis (which is materially consistent with the effective interest method) over the expected terms of the respective debt instrument to which the costs relate and is included in interest expense. Debt issuance cost amortization expense was \$5.5 million, \$5.6 million and \$7.5 million in 2023, 2022 and 2021, respectively.

Insurance Reserves

The Company has retention programs for workers' compensation, general liability and owned and non-owned automobile liabilities for certain periods prior to December 1998 and for periods after December 2001. The Company is generally responsible for up to \$2.0 million per occurrence under these retention programs for workers' compensation and general liability exposures. The Company is also generally responsible for between \$500,000 and \$5.5 million per occurrence under these retention programs for owned and non-owned automobile liabilities depending on the year. Total insurance limits under these retention programs vary depending on the year covered and range up to \$110.0 million per occurrence for general liability and owned and non-owned automobile liabilities and up to the applicable statutory limits for workers' compensation.

Casualty insurance reserves relating to the Company's retention programs are based on undiscounted actuarial estimates. These estimates are based on historical information and on certain assumptions about future events. Changes in assumptions for such factors as medical costs and legal actions, as well as changes in actual experience, could cause these estimates to change in the near term. The Company generally receives estimates of outstanding casualty insurance exposures from its independent actuary twice per year and differences between these estimated actuarial exposures and the Company's recorded amounts are adjusted as appropriate. The Company had reserves for these programs of \$56.3 million and \$57.6 million as of December 31, 2023 and January 1, 2023, respectively.

In addition, the Company maintains reserves for its share of employee health costs as part of the health care benefits offered to its employees. Reserves are based on estimated claims incurred that have not yet been paid, based on historical claims and payment lag times.

Contract Liabilities

Contract liabilities consist primarily of deferred franchise fees and deferred development fees. Deferred franchise fees and deferred development fees of \$5.3 million and \$5.5 million were included in current other accrued liabilities as of December 31, 2023 and January 1, 2023, respectively. Deferred franchise fees and deferred development fees of \$19.9 million and \$22.7 million were included in long-term other accrued liabilities as of December 31, 2023 and January 1, 2023, respectively.

Changes in deferred franchise fees and deferred development fees in 2023 and 2022 were as follows:

	Fiscal Year Ended	
	December 31, 2023	January 1, 2023
Deferred franchise fees and deferred development fees, beginning of period	\$ 28,225	\$ 29,694
Revenue recognized during the period	(6,468)	(6,654)
New deferrals due to cash received and other	3,438	5,185
Deferred franchise fees and deferred development fees, end of period	<u>\$ 25,195</u>	<u>\$ 28,225</u>

The Company expects to recognize revenue associated with deferred franchise fees and deferred development fees as follows in the table below. The Company has applied the sales-based royalty exemption which permits exclusion of variable consideration in the form of sales-based royalties from the disclosure of remaining performance obligations.

2024	\$	5,301
2025		4,975
2026		4,634
2027		3,157
2028		2,025
Thereafter		5,103
	<u>\$</u>	<u>25,195</u>

Other Accrued Liabilities

Current and long-term other accrued liabilities primarily include accruals for income, sales, property and other taxes, legal reserves, operating expenses, dividends payable, deferred compensation, unredeemed gift cards and contract liabilities. The Company had \$38.9 million and \$29.2 million included in other current accrued liabilities related to unredeemed gift cards as of December 31, 2023 and January 1, 2023, respectively.

Foreign Currency Translation

The Company's foreign entities use their local currency as the functional currency. For these entities, the Company translates net assets into U.S. dollars at year end exchange rates, while income and expense accounts are translated at average annual exchange rates. Currency translation adjustments are included in accumulated other comprehensive income (loss) and foreign currency transaction gains and losses are included in determining net income.

Revenue Recognition

U.S. Company-owned stores revenues are comprised of retail sales of food through Company-owned Domino's Pizza stores located in the U.S. and are recognized when the items are delivered to or carried out by customers. Customer payments are generally due at the time of sale. Sales taxes related to these sales are collected from customers and remitted to the appropriate taxing authority and are not reflected in the Company's consolidated statements of income as revenue.

U.S. franchise royalties and fees are primarily comprised of royalties and fees from Domino's Pizza franchisees with operations in the U.S. Each franchisee is generally required to pay a 5.5% royalty fee on sales. In certain instances, the Company will collect lower rates based on area development agreements, sales initiatives, store relocation incentives and new store incentives. Royalty revenues are based on a percentage of franchise retail sales and are recognized when the items are delivered to or carried out by franchisees' customers. U.S. franchise fee revenue primarily relates to per-transaction technology fees that are recognized as the related sales occur. Payments for U.S. royalties and fees are generally due within seven days of the prior week end date.

Supply chain revenues are primarily comprised of sales of food, equipment and supplies to franchised Domino's Pizza stores located in the U.S. and Canada. Revenues from the sale of food are recognized upon delivery of the food to franchisees and payments for food purchases are generally due within 30 days of the shipping date. Revenues from the sale of equipment and supplies are recognized upon delivery or shipment of the related products to franchisees, based on shipping terms, and payments for equipment and supplies are generally due within 90 days of the shipping date. The Company also offers profit sharing rebates and volume discounts to its franchisees. Obligations for profit sharing rebates are calculated based on actual results of its supply chain centers and are recognized as a reduction to revenue. Volume discounts are based on annual sales. The Company estimates the amount that will be earned and records a reduction to revenue throughout the year.

International franchise royalties and fees are primarily comprised of royalties and fees from Domino's Pizza franchisees outside of the U.S. Royalty revenues are recognized when the items are delivered to or carried out by franchisees' customers. Franchise fees received from international franchisees are recognized as revenue on a straight-line basis over the term of each respective franchise store agreement, which is typically ten years. Development fees received from international master franchisees are also deferred when amounts are received and are recognized as revenue on a straight-line basis over the term of the respective master franchise agreement, which is typically ten years. International franchise fee revenues primarily relate to per-transaction technology fees that are recognized as the related sales occur. International franchise royalties and fees are invoiced at least quarterly, and payments are generally due within 60 days.

U.S. franchise advertising revenues are comprised of contributions from Domino's Pizza franchisees with operations in the U.S. to the Domino's National Advertising Fund Inc. ("DNAF"), the Company's consolidated not-for-profit subsidiary that administers the Domino's Pizza system's national and market level advertising activities in the U.S. Each franchisee is generally required to contribute 6.0% of their retail sales to fund national marketing and advertising campaigns (subject, in certain instances, to lower rates based on certain incentives and waivers). Beginning on March 27, 2023, the Company effectuated a temporary reduction of 0.25% to its standard 6.0% advertising contribution, which will expire on March 24, 2024. These revenues are recognized when items are delivered to or carried out by franchisees' customers. Payments for U.S. franchise advertising revenues are generally due within seven days of the prior week end date. Although these revenues are restricted to be used only for advertising and promotional activities to benefit franchised stores, the Company has determined there are not performance obligations associated with the franchise advertising contributions received by DNAF that are separate from its U.S. royalty payment stream and as a result, these franchise contributions and the related expenses are presented gross in the Company's consolidated statements of income.

Disaggregation of Revenue

Current accounting standards require that companies disaggregate revenue from contracts with customers into categories that depict how the nature, amount, timing, and uncertainty of revenue and cash flows are affected by economic factors. The Company has included its revenues disaggregated in its consolidated statements of income to satisfy this requirement.

Supply Chain Profit-Sharing Arrangements

The Company enters into profit-sharing arrangements with U.S. and Canadian franchisees that purchase all of their food from the Company's supply chain centers. These profit-sharing arrangements generally offer Company-owned stores and participating franchisees 50% of the pre-tax profit from the Company's supply chain center operations. Profit-sharing obligations are recorded as a reduction to supply chain revenues in the same period as the related revenues and costs are recorded, and were \$138.7 million, \$110.0 million and \$148.3 million in 2023, 2022 and 2021, respectively.

Cost of Sales

Cost of sales consists primarily of U.S. Company-owned store and supply chain costs incurred to generate related revenues. Components of consolidated cost of sales primarily include food, labor, delivery, occupancy costs (including rent, telephone, utilities and depreciation) and insurance expense.

General and Administrative

General and administrative expense consists primarily of labor cost (including variable performance-based compensation expense and non-cash Parent equity-based compensation expense), depreciation and amortization, computer expenses, professional fees, travel and entertainment, rent, insurance and other corporate administrative costs.

Advertising

U.S. stores are generally required to contribute 6.0% of sales to DNAF (subject, in certain instances, to lower rates based on certain incentives and waivers). Beginning on March 27, 2023, the Company effectuated a temporary reduction of 0.25% to its standard 6.0% advertising contribution, which will expire on March 24, 2024.

U.S. franchise advertising costs are accrued and expensed when the related U.S. franchise advertising revenues are recognized, as DNAF is obligated to expend such revenues on advertising and other activities that promote the Domino's brand. U.S. franchise advertising costs expended by DNAF are included in U.S. franchise advertising expenses in the Company's consolidated statements of income. Advertising costs funded by Company-owned stores are generally expensed as incurred and are included in general and administrative expense. Contributions from Company-owned stores that have not yet been expended are included in advertising fund assets, restricted on the Company's consolidated balance sheets.

Advertising expense included \$473.2 million, \$485.3 million and \$479.5 million of U.S. franchise advertising expense in 2023, 2022 and 2021, respectively. Advertising expense also included \$33.5 million, \$33.8 million and \$42.1 million in 2023, 2022 and 2021, respectively, primarily related to advertising costs funded by U.S. Company-owned stores and other general marketing expenses which are included in general and administrative expense in the consolidated statements of income.

As of December 31, 2023, advertising fund assets, restricted of \$106.3 million consisted of \$88.2 million of cash and cash equivalents, \$14.0 million of accounts receivable and \$4.1 million of prepaid expenses. As of December 31, 2023, advertising fund cash and cash equivalents included \$2.1 million of cash contributed from U.S. Company-owned stores that had not yet been expended.

As of January 1, 2023, advertising fund assets, restricted of \$162.7 million consisted of \$143.6 million of cash and cash equivalents, \$13.1 million of accounts receivable and \$6.0 million of prepaid expenses. As of January 1, 2023, advertising fund cash and cash equivalents included \$4.8 million of cash contributed from U.S. Company-owned stores that had not yet been expended.

Leases

The Company leases certain retail store and supply chain center locations, vehicles, equipment and its corporate headquarters. The Company determines whether an arrangement is or contains a lease at contract inception. The majority of the Company's leases are classified as operating leases, which are included in operating lease right-of-use assets and operating lease liabilities in the Company's consolidated balance sheets. Finance leases are included in property, plant and equipment, current portion of long-term debt and long-term debt on the Company's consolidated balance sheets.

Right-of-use assets and lease liabilities are recognized based on the present value of the future minimum lease payments over the lease term at the commencement date for leases exceeding 12 months. Minimum lease payments include only the fixed lease component of the agreement, as well as any variable rate payments that depend on an index, initially measured using the index at the lease commencement date. Lease terms may include options to renew when it is reasonably certain that the Company will exercise that option.

The Company estimates its incremental borrowing rate for each lease using a portfolio approach based on the respective weighted average term of the agreements. This estimation considers the market rates of the Company's outstanding collateralized borrowings and interpolations of rates outside of the terms of the outstanding borrowings, including comparisons to comparable borrowings of similarly rated companies with longer term borrowings.

Operating lease expense is recognized on a straight-line basis over the lease term and is included in cost of sales or general and administrative expense. Amortization expense for finance leases is recognized on a straight-line basis over the lease term and is included in cost of sales or general and administrative expense. Interest expense for finance leases is recognized using the effective interest method. Variable lease payments that do not depend on a rate or index, payments associated with non-lease components and short-term rentals (leases with terms less than 12 months) are expensed as incurred.

Contributions

During the normal course of business, the Company receives contributions from the Parent related to the proceeds received from the issuance of shares of the Parent's common stock and from the exercise of Parent stock options. The Company received contributions from the Parent related to proceeds from the exercises of Parent stock options of \$8.7 million, \$3.3 million and \$19.7 million in 2023, 2022 and 2021, respectively.

Distributions

During the normal course of business, the Company makes discretionary distributions to Domino's and the Parent allowing for the payment of certain taxes, declaration and payment of dividends and repurchases of shares of the Parent's common stock. The Company made discretionary distributions to the Parent of \$444.2 million, \$462.0 million and \$1.47 billion in 2023, 2022 and 2021, respectively.

Parent Stock Options and Other Parent Equity-Based Compensation Arrangements

The cost of all of the Parent's stock options, as well as other equity-based compensation arrangements, is reflected in the financial statements based on the estimated fair value of the awards (Note 8).

Supplemental Disclosures of Cash Flow Information

The Company paid interest of \$186.8 million, \$188.5 million and \$174.6 million during 2023, 2022 and 2021, respectively, on its Notes (Note 2). Cash paid for income taxes was \$136.3 million, \$134.4 million and \$106.3 million in 2023, 2022 and 2021, respectively.

The Company had non-cash investing activities related to accruals for capital expenditures of \$6.7 million, \$6.9 million and \$5.4 million at December 31, 2023, January 1, 2023 and January 2, 2022, respectively. As of December 31, 2023, the Company also had \$2.6 million in non-cash financing activity related to accruals for excise taxes on share repurchases of the Parent. The Company had \$0.1 million, \$0.1 million and \$0.4 million of non-cash investing activities related to lease incentives in 2023, 2022 and 2021 respectively.

New Accounting Pronouncements

Recently Adopted Accounting Standards

The Company has considered all new accounting standards issued by the Financial Accounting Standards Board ("FASB") and adopted the following accounting standards.

Accounting Standards Update ("ASU") 2020-04, Facilitation of the Effects of Reference Rate Reform on Financial Reporting, updated by *ASU 2022-06, Deferral of the Sunset Date of Topic 848 ("ASU 2022-06")*

In March 2020, the FASB issued *ASU 2020-04, Reference Rate Reform (Topic 848): Facilitation of the Effects of Reference Rate Reform on Financial Reporting ("ASU 2020-04")*, which provides temporary optional expedients and exceptions for applying generally accepted accounting principles to contracts, hedging relationships and other transactions affected by reference rate reform. On May 15, 2023, certain of the Company's subsidiaries executed an amendment to the Company's 2021 variable funding notes to affect the transition from LIBOR to the Secured Overnight Financing Rate ("Term SOFR"), plus a spread adjustment. In connection with this contract amendment, the Company adopted ASU 2020-04 (as updated by ASU 2022-06) in the second quarter of 2023. The amendment to the Company's 2021 variable funding notes and the adoption of this accounting standard did not have a material impact on the Company's consolidated financial statements.

ASU 2022-03, Fair Value Measurement (Topic 820): Fair Value Measurement of Equity Securities Subject to Contractual Sale Restrictions

In June 2022, the FASB issued *ASU 2022-03, Fair Value Measurement (Topic 820): Fair Value Measurement of Equity Securities Subject to Contractual Sale Restrictions ("ASU 2022-03")*, which clarifies and amends the guidance of measuring the fair value of equity securities subject to contractual sale restrictions. ASU 2022-03 also requires disclosure of the fair value of equity securities subject to contractual sale restrictions, the nature and remaining duration of the restrictions and the circumstances that could cause a lapse in the restrictions. The Company's investment in DPC Dash (Note 5) is subject to contractual restrictions that prohibit the Company from selling the security for 360 days following DPC Dash's initial public offering. The Company early adopted ASU 2022-03 in the second quarter of 2023 and the adoption of this accounting standard did not have a material impact on the Company's consolidated financial statements.

Accounting Standards Not Yet Adopted

The Company has considered all new accounting pronouncements issued by the FASB. The Company has not yet adopted the following standard:

ASU 2023-09, Income Taxes (Topic 740): Improvements to Income Tax Disclosures

In December 2023, the FASB issued *ASU 2023-09, Income Taxes (Topic 740): Improvements to Income Tax Disclosures*, which requires disclosure on an annual basis, a tabular reconciliation, including both reporting currency and percentages of specific categories of the effective tax rate reconciliation, including state and local income taxes (net of Federal taxes), foreign taxes, effects of changes in tax laws and regulations, effects of cross-border tax laws, tax credits, changes in valuation allowances, nontaxable and nondeductible items and changes in unrecognized tax benefits. Additional disclosures are required for certain items exceeding five percent of income from continuing operations multiplied by the statutory income tax rate. The standard also requires disclosure of income taxes paid between Federal, state and foreign jurisdictions, including further disaggregation of those payments exceeding five percent of the total income taxes paid.

ASU 2023-09 is effective for fiscal years beginning after December 15, 2025, and early adoption is permitted. The Company is currently evaluating the impact of this accounting standard on its consolidated financial statements.

Use of Estimates

The preparation of financial statements in conformity with accounting principles generally accepted in the U.S. requires management to make estimates and assumptions that affect the reported amounts of assets and liabilities and disclosures of contingent assets and liabilities at the date of the consolidated financial statements and the reported amounts of revenues and expenses during the reporting period. Actual results could differ from those estimates.

Subsequent Events

The Company evaluated subsequent events occurring after December 31, 2023 through the date the consolidated financial statements were available to be issued on March 18, 2024. Based on this evaluation, the Company determined there were no subsequent events that required recognition or disclosure.

(2) Recapitalizations and Financing Arrangements

The 2021 Notes, 2019 Notes, 2018 Notes, 2017 Notes and 2015 Notes (each, as defined below) are collectively referred to as the “Notes.” The Company made payments of \$51.5 million, \$51.5 million and \$907.0 million in 2023, 2022 and 2021, respectively on the Notes. The Company borrowed and repaid \$120.0 million under its 2021 Variable Funding Notes (as defined below) in 2022.

2021 Recapitalization

On April 16, 2021, the Company completed a recapitalization transaction (the “2021 Recapitalization”) in which certain of the Company’s subsidiaries issued notes pursuant to an asset-backed securitization. The notes consist of \$850.0 million Series 2021-1 2.662% Fixed Rate Senior Secured Notes, Class A-2-I with an anticipated term of 7.5 years (the “2021 7.5-Year Notes”) and \$1.0 billion Series 2021-1 3.151% Fixed Rate Senior Secured Notes, Class A-2-II with an anticipated term of 10 years (the “2021 Ten-Year Notes”, and, collectively with the 2021 7.5-Year Notes, the “2021 Notes”). Gross proceeds from the issuance of the 2021 Notes were \$1.85 billion.

Concurrently, certain of the Company’s subsidiaries also issued a new variable funding note facility which allows for advances of up to \$200.0 million of Series 2021-1 Variable Funding Senior Secured Notes, Class A-1 Notes and certain other credit instruments, including letters of credit (the “2021 Variable Funding Notes”). In connection with the issuance of the 2021 Variable Funding Notes, the Company’s 2019 Variable Funding Notes (as defined below) were canceled.

The proceeds from the 2021 Recapitalization were used to repay the remaining \$291.0 million in outstanding principal under the Company’s 2017 Floating Rate Notes (as defined below) and \$582.0 million in outstanding principal under the Company’s 2017 Five-Year Notes (as defined below), prefund a portion of the interest payable on the 2021 Notes, pay transaction fees and expenses and repurchase and retire shares of the Parent’s common stock.

2019 Recapitalization

On November 19, 2019, the Company completed a recapitalization transaction (the “2019 Recapitalization”) in which certain of the Company’s subsidiaries issued notes pursuant to an asset-backed securitization. The notes consist of \$675.0 million Series 2019-1 3.668% Fixed Rate Senior Secured Notes, Class A-2 with an anticipated term of 10 years (the “2019 Notes”). The Company also entered into a variable funding note facility, which allowed for the issuance of up to \$200.0 million Series 2019-1 Variable Funding Senior Secured Notes, Class A-1 (the “2019 Variable Funding Notes”) and certain other credit instruments, including letters of credit. Gross proceeds from the issuance of the 2019 Notes were \$675.0 million.

2018 Recapitalization

On April 24, 2018, the Company completed a recapitalization transaction (the “2018 Recapitalization”) in which certain of the Company’s subsidiaries issued notes pursuant to an asset-backed securitization. The notes consist of \$425.0 million Series 2018-1 4.116% Fixed Rate Senior Secured Notes, Class A-2-I with an anticipated term of 7.5 years (the “2018 7.5-Year Notes”), and \$400.0 million Series 2018-1 4.328% Fixed Rate Senior Secured Notes, Class A-2-II with an anticipated term of 9.25 years (the “2018 9.25-Year Notes” and, collectively with the 2018 7.5-Year Notes, the “2018 Notes”). Gross proceeds from the issuance of the 2018 Notes were \$825.0 million.

2017 Recapitalization

On July 24, 2017, the Company completed a recapitalization transaction (the “2017 Recapitalization”) in which certain of the Company’s subsidiaries issued notes pursuant to an asset-backed securitization. The notes consisted of \$300.0 million Series 2017-1 Floating Rate Senior Secured Notes, Class A-2-I with an anticipated term of five years (the “2017 Floating Rate Notes”), \$600.0 million Series 2017-1 3.082% Fixed Rate Senior Secured Notes, Class A-2-II with an anticipated term of five years (the “2017 Five-Year Notes”) and \$1.0 billion Series 2017-1 4.118% Fixed Rate Senior Secured Notes, Class A-2-III with an anticipated term of ten years (the “2017 Ten-Year Notes” and, collectively with the 2017 Floating Rate Notes and the 2017 Five-Year Notes, the “2017 Notes”). The interest rate on the 2017 Floating Rate Notes was payable at a rate equal to LIBOR plus 125 basis points. Gross proceeds from the issuance of the 2017 Notes were \$1.9 billion.

2015 Recapitalization

On October 21, 2015, the Company completed a recapitalization transaction (the “2015 Recapitalization”) in which certain of the Company’s subsidiaries issued notes pursuant to an asset-backed securitization. The notes consisted of \$500.0 million Series 2015-1 3.484% Fixed Rate Senior Secured Notes, Class A-2-I (the “2015 Five-Year Notes”) and \$800.0 million Series 2015-1 4.474% Fixed Rate Senior Secured Notes, Class A-2-II (the “2015 Ten-Year Notes” and, together with the 2015 Five-Year Notes, the “2015 Notes”). Gross proceeds from the issuance of the 2015 Notes were \$1.3 billion.

2022 Variable Funding Notes

On September 16, 2022, certain of the Company’s subsidiaries issued a new variable funding note facility which allows for advances of up to \$120.0 million of Series 2022-1 Variable Funding Senior Secured Notes, Class A-1 Notes (the “2022 Variable Funding Notes”). The facility was undrawn at closing. Interest on the 2022 Variable Funding Notes is payable at a per year rate equal to Secured Overnight Financing Rate, plus a spread adjustment (“Adjusted Term SOFR”), plus 150 basis points. The unused portion of the 2022 Variable Funding Notes is subject to a commitment fee of 50 basis points. It is anticipated that any amounts outstanding on the 2022 Variable Funding Notes will be repaid in full on or prior to April 2026, subject to two additional one-year extensions at the option of the Company, subject to certain conditions. Following the anticipated repayment date (and any extensions thereof), additional interest will accrue on the 2022 Variable Funding Notes equal to 5% per annum.

As of December 31, 2023 and January 1, 2023, the Company had no outstanding borrowings and \$120.0 million of available borrowing capacity under its 2022 Variable Funding Notes.

2021 Notes

The 2021 Notes have remaining scheduled principal payments of \$18.5 million in each of 2024 through 2027, \$804.8 million in 2028, \$10.0 million in each of 2029 and 2030 and \$905.0 million in 2031.

The legal final maturity date of the 2021 Notes is April 2051, but it is anticipated that, unless earlier prepaid to the extent permitted under the related debt agreements, the 2021 7.5-Year Notes will be repaid on or prior to the anticipated repayment date occurring in October 2028, and the 2021 Ten-Year Notes will be repaid on or prior to the anticipated repayment date occurring in April 2031. If the Company has not repaid or refinanced the 2021 Notes prior to the applicable anticipated repayment dates, additional interest of at least 5% per annum will accrue, as defined in the related agreements.

The 2021 Variable Funding Notes allow for advances of up to \$200.0 million and issuance of certain other credit instruments, including letters of credit. The letters of credit are primarily related to our casualty insurance programs and certain supply chain center leases. On May 15, 2023, certain of the Company's subsidiaries executed an amendment to the Company's 2021 Variable Funding Notes to affect the transition from LIBOR to Adjusted Term SOFR. Certain clarifying amendments were effectuated on September 19, 2023. The interest rate on the 2021 Variable Funding Notes is payable at a per year rate equal to Adjusted Term SOFR, plus 150 basis points. The 2021 Variable Funding Notes were undrawn at closing of the 2021 Recapitalization. The unused portion of the 2021 Variable Funding Notes is subject to a commitment fee ranging from 50 to 100 basis points depending on utilization. It is anticipated that any amounts outstanding on the 2021 Variable Funding Notes will be repaid in full on or prior to April 2026, subject to two additional one-year extensions at the option of the Company, subject to certain conditions. Following the anticipated repayment date (and any extensions thereof), additional interest will accrue on the 2021 Variable Funding Notes equal to 5% per annum.

As of December 31, 2023 and January 1, 2023, the Company had no outstanding borrowings and \$157.8 million of available borrowing capacity under its 2021 Variable Funding Notes, net of letters of credit issued of \$42.2 million.

2019 Notes

The 2019 Notes have remaining scheduled principal payments of \$6.8 million in each of 2024 through 2028 and \$615.9 million in 2029.

The legal final maturity date of the 2019 Notes is October 2049, but it is anticipated that, unless earlier prepaid to the extent permitted under the related debt agreements, the 2019 Notes will be repaid on or prior to the anticipated repayment date occurring in October 2029. If the Company has not repaid or refinanced the 2019 Notes prior to the applicable anticipated repayment dates, additional interest of at least 5% per annum will accrue, as defined in the related agreements.

The 2019 Variable Funding Notes allowed for advances of up to \$200.0 million and issuance of certain other credit instruments, including letters of credit. The letters of credit are primarily related to our casualty insurance programs and certain supply chain center leases. Interest on the 2019 Variable Funding Notes was payable at a per year rate equal to LIBOR plus 150 basis points. The 2019 Variable Funding Notes were cancelled in connection with the 2021 Recapitalization.

2018 Notes

The 2018 Notes have remaining scheduled principal payments of \$8.3 million in 2024, \$403.5 million in 2025, \$4.0 million in 2026 and \$368.0 million in 2027.

The legal final maturity date of the 2018 Notes is July 2048, but it is anticipated that, unless earlier prepaid to the extent permitted under the related debt agreements, the 2018 7.5-Year Notes will be repaid on or prior to the anticipated repayment date occurring in October 2025, and the 2018 9.25-Year Notes will be repaid on or prior to the anticipated repayment date occurring in July 2027. If the Company has not repaid or refinanced the 2018 Notes prior to the applicable anticipated repayment dates, additional interest of at least 5% per annum will accrue, as defined in the related agreements.

2017 Notes

The 2017 Five-Year Notes and the 2017 Floating Rate Notes were repaid in connection with the 2021 Recapitalization. The 2017 Ten-Year Notes have remaining scheduled principal payments of \$10.0 million in each of 2024 through 2026 and \$912.5 million in 2027.

The legal final maturity date of the 2017 Ten-Year Notes is October 2047, but it is anticipated that, unless earlier prepaid to the extent permitted under the related debt agreements, the 2017 Ten-Year Notes will be repaid on or prior to the anticipated repayment date occurring in July 2027. If the Company has not repaid or refinanced the 2017 Ten-Year Notes prior to the applicable anticipated repayment dates, additional interest of at least 5% per annum will accrue, as defined in the related agreements.

2015 Notes

The 2015 Five-Year Notes were repaid in connection with the 2018 Recapitalization. The 2015 Ten-Year Notes have original remaining scheduled principal payments of \$8.0 million in 2024 and \$736.0 million in 2025.

The legal final maturity date of the 2015 Ten-Year Notes is in October 2045, but it is anticipated that, unless earlier prepaid to the extent permitted under the related debt agreements, the 2015 Ten-Year Notes will be repaid on or prior to the anticipated repayment date occurring in October 2025. If the Company has not repaid or refinanced the 2015 Ten-Year Notes prior to the applicable anticipated repayment date, additional interest of at least 5% per annum will accrue, as defined in the related agreements.

Debt Issuance Costs and Transaction-Related Expenses

During 2022 and in connection with the issuance of the 2022 Variable Funding Notes, the Company capitalized \$1.6 million of financing costs, which are recorded in long-term other assets in the Company's consolidated balance sheets and are being amortized into interest expense over the remaining term of the 2022 Variable Funding Notes.

During 2021 and in connection with the 2021 Recapitalization, the Company incurred approximately \$2.8 million of net pre-tax expenses, primarily related to \$2.0 million in expense related to the write-off of debt issuance costs associated with the repayment of the 2017 Five-Year Notes and 2017 Floating Rate Notes. The Company also incurred approximately \$0.3 million of interest expense on the 2017 Five-Year Notes and the 2017 Floating Rate Notes subsequent to the closing of the Company's 2021 Recapitalization, but prior to the repayment of the 2017 Five-Year Notes and the 2017 Floating Rate Notes, resulting in the payment of interest on both the 2017 Five-Year Notes and the 2017 Floating Rate Notes as well as the 2021 Notes for a short period of time. Further, the Company incurred \$0.5 million of 2021 Recapitalization-related general and administrative expenses, including legal and professional fees. In connection with the 2021 Recapitalization, the Company recorded \$14.9 million of debt issuance costs, which are being amortized into interest expense over the respective terms of the 2021 Notes.

Guarantees and Covenants of the Notes

The Notes are guaranteed by certain subsidiaries of DPLLC and secured by a security interest in substantially all of the assets of the Company, including royalty and certain other income from all U.S. and international stores, U.S. supply chain income and intellectual property. The restrictions placed on the Company's subsidiaries require that the Company's principal and interest obligations have first priority and amounts are segregated weekly to ensure appropriate funds are reserved to pay the quarterly principal and interest amounts due. The amount of weekly cash flow that exceeds the required weekly principal and interest reserve is generally remitted to the Company in the form of a dividend. However, once the required obligations are satisfied, there are no further restrictions, including payment of dividends, on the cash flows of the subsidiaries.

The Notes are subject to certain financial and non-financial covenants, including a debt service coverage ratio calculation. The covenant requires a minimum coverage ratio of 1.75x total debt service to securitized net cash flow, as defined in the related agreements. The covenants, among other things, may limit the ability of certain of the Company's subsidiaries to declare dividends, make loans or advances or enter into transactions with affiliates. In the event that certain covenants are not met, the Notes may become partially or fully due and payable on an accelerated schedule. In addition, the Company may voluntarily prepay, in part or in full, the Notes at any time, subject to certain make-whole interest obligations.

While the Notes are outstanding, scheduled payments of principal and interest are required to be made on a quarterly basis. The payment of principal of the Notes may be suspended if the leverage ratio for the Company is less than or equal to 5.0x total debt, as defined, to adjusted EBITDA, as defined in the related agreements. Scheduled principal payments will resume upon failure to satisfy the aforementioned leverage ratio on an ongoing basis and no catch-up provisions are applicable.

As of the fourth quarter of 2020, the Company had a leverage ratio of less than 5.0x, and accordingly, did not make the previously scheduled debt amortization payment in the first quarter of 2021. Subsequent to the closing of the 2021 Recapitalization, the Company had a leverage ratio of greater than 5.0x and, accordingly, the Company resumed making the scheduled amortization payments on its then outstanding notes in the second quarter of 2021.

Consolidated Long-Term Debt

At December 31, 2023 and January 1, 2023, consolidated long-term debt consisted of the following:

	December 31, 2023	January 1, 2023
2015 Ten-Year Notes	\$ 744,000	\$ 752,000
2017 Ten-Year Notes	942,500	952,500
2018 7.5-Year Notes	403,750	408,000
2018 9.25-Year Notes	380,000	384,000
2019 Ten-Year Notes	649,688	656,438
2021 7.5-Year Notes	828,750	837,250
2021 Ten-Year Notes	975,000	985,000
Finance lease obligations	73,482	74,199
Financing obligation from sale leaseback	14,877	—
Debt issuance costs, net of accumulated amortization of \$29.2 million in 2023 and \$23.6 million in 2022	(21,619)	(27,154)
Total debt	4,990,428	5,022,233
Current portion of long-term debt	(56,366)	(54,813)
Long-term debt, less current portion	\$ 4,934,062	\$ 4,967,420

At December 31, 2023, maturities of long-term debt, financing obligations and finance leases were as follows:

2024	\$ 56,366
2025	1,179,900
2026	45,343
2027	1,310,978
2028	815,888
Thereafter	1,603,572
	\$ 5,012,047

(3) Fair Value Measurements

Fair value measurements enable the reader of the financial statements to assess the inputs used to develop those measurements by establishing a hierarchy for ranking the quality and reliability of the information used to determine fair values. The Company classifies and discloses assets and liabilities carried at fair value in one of the following three categories:

Level 1: Quoted market prices in active markets for identical assets or liabilities.

Level 2: Observable market-based inputs or unobservable inputs that are corroborated by market data.

Level 3: Unobservable inputs that are not corroborated by market data.

Fair Value of Cash Equivalents and Marketable Securities

The fair values of the Company's cash equivalents and investments in marketable securities are based on quoted prices in active markets for identical assets.

Fair Value of Investments

The Company holds a non-controlling interest in DPC Dash, the Company's master franchisee in China that owns and operates Domino's Pizza stores in that market.

As of December 31, 2023, the fair value of the Company's investment in DPC Dash is based on the active exchange quoted price for the equity security of HK\$61.95 per share. The Company recorded a total net adjustment to the carrying amount of its investment in DPC Dash of \$17.7 million in 2023, with the gain recorded in other income in its consolidated statements of income. As of January 1, 2023, the fair value of the Company's investment in DPC Dash was not readily determinable and was categorized in Level 3 of the fair value hierarchy. The Company did not record any adjustments to the carrying amount of its investment in 2022. In 2021, the Company recorded positive adjustments of \$2.5 million and \$34.3 million resulting from the observable change in price from the valuation of the additional investments made by the Company during the 2021 fiscal year. The Company transferred its investment from Level 3 to Level 1 on March 28, 2023, concurrent with DPC Dash's initial public offering.

The following table summarizes the carrying amounts and fair values of certain assets at December 31, 2023:

	At December 31, 2023			
	Carrying Amount	Fair Value Estimated Using		
		Level 1 Inputs	Level 2 Inputs	Level 3 Inputs
Cash equivalents	\$ 50,732	\$ 50,732	\$ —	\$ —
Restricted cash equivalents	133,063	133,063	—	—
Investments in marketable securities	16,720	16,720	—	—
Advertising fund cash equivalents, restricted	69,199	69,199	—	—
Investment in DPC Dash	143,553	143,553	—	—

The following table summarizes the carrying amounts and fair values of certain assets at January 1, 2023:

	At January 1, 2023			
	Carrying Amount	Fair Value Estimated Using		
		Level 1 Inputs	Level 2 Inputs	Level 3 Inputs
Cash equivalents	\$ 23,779	\$ 23,779	\$ —	\$ —
Restricted cash equivalents	117,212	117,212	—	—
Investments in marketable securities	13,395	13,395	—	—
Advertising fund cash equivalents, restricted	124,496	124,496	—	—
Investment in DPC Dash	125,840	—	—	125,840

Fair Value of Debt

The estimated fair values of the Company's Notes (Note 2) are classified as Level 2 measurements, as the Company estimates the fair value amount by using available market information. The Company obtained quotes from two separate brokerage firms that are knowledgeable about the Company's Notes and, at times, trade these Notes. The Company also performed its own internal analysis based on the information gathered from public markets, including information on notes that are similar to those of the Company. However, considerable judgment is required to interpret market data to estimate fair value. Accordingly, the fair value estimates presented are not necessarily indicative of the amount that the Company or the noteholders could realize in a current market exchange. The use of different assumptions and/or estimation methodologies may have a material effect on the estimated fair values stated below.

Management estimated the approximate fair values of the Notes as follows:

	December 31, 2023		January 1, 2023	
	Principal Amount	Fair Value	Principal Amount	Fair Value
2015 Ten-Year Notes	\$ 744,000	\$ 727,632	\$ 752,000	\$ 717,408
2017 Ten-Year Notes	942,500	895,375	952,500	875,348
2018 7.5-Year Notes	403,750	392,041	408,000	385,968
2018 9.25-Year Notes	380,000	365,180	384,000	355,584
2019 Ten-Year Notes	649,688	591,865	656,438	564,536
2021 7.5-Year Notes	828,750	730,958	837,250	695,755
2021 Ten-Year Notes	975,000	830,700	985,000	792,925

The Company did not have any outstanding borrowings under its variable funding notes at December 31, 2023 or January 1, 2023.

(4) Leases

The Company leases certain retail store and supply chain center locations, vehicles, equipment and its corporate headquarters with expiration dates through 2045.

The components of operating and finance lease cost for 2023, 2022 and 2021 were as follows:

	<u>2023</u>	<u>2022</u>	<u>2021</u>
Operating lease cost	\$ 47,579	\$ 47,039	\$ 44,913
Finance lease cost:			
Amortization of right-of-use assets	5,545	5,235	4,373
Interest on lease liabilities	4,340	4,369	4,233
Total finance lease cost	<u>\$ 9,885</u>	<u>\$ 9,604</u>	<u>\$ 8,606</u>

Rent expense totaled \$85.6 million, \$79.6 million and \$78.6 million in 2023, 2022 and 2021, respectively. Rent expense includes operating lease cost, as well as expense for non-lease components including common area maintenance, real estate taxes and insurance for the Company's real estate leases. Rent expense also includes the variable rate per mile driven and fixed maintenance charges for the Company's supply chain center tractors and trailers and expense for short-term rentals. Rent expense for certain short-term supply chain center tractor and trailer rentals was \$5.4 million, \$7.0 million and \$8.0 million in 2023, 2022 and 2021, respectively. Variable rent expense and rent expense for other short-term leases were immaterial for 2023, 2022 and 2021.

Supplemental balance sheet information related to the Company's finance leases as of December 31, 2023 and January 1, 2023 was as follows:

	<u>December 31, 2023</u>	<u>January 1, 2023</u>
Land and buildings	\$ 83,969	\$ 83,902
Equipment	4,284	1,606
Finance lease assets	88,253	85,508
Accumulated depreciation and amortization	(24,159)	(19,405)
Finance lease assets, net	<u>\$ 64,094</u>	<u>\$ 66,103</u>
Current portion of long-term debt	\$ 4,778	\$ 3,313
Long-term debt, less current portion	68,704	70,886
Total principal payable on finance leases	<u>\$ 73,482</u>	<u>\$ 74,199</u>

As of December 31, 2023 and January 1, 2023, the weighted average remaining lease term and weighted average discount rate for the Company's operating and finance leases were as follows:

	<u>2023</u>		<u>2022</u>	
	<u>Operating Leases</u>	<u>Finance Leases</u>	<u>Operating Leases</u>	<u>Finance Leases</u>
Weighted average remaining lease term	7 years	13 years	7 years	14 years
Weighted average discount rate	4.3%	6.1%	3.9%	6.0%

Supplemental cash flow information related to leases for 2023, 2022 and 2021 was as follows:

	<u>2023</u>	<u>2022</u>	<u>2021</u>
Cash paid for amounts included in the measurement of lease liabilities:			
Operating cash flows from operating leases	\$ 46,936	\$ 45,082	\$ 44,176
Operating cash flows from finance leases	4,340	4,369	4,233
Financing cash flows from finance leases	4,184	4,176	3,212
Cash paid for amounts included in the measurement of financing obligation from sale leaseback:			
Operating cash flows from sale leaseback	201	—	—
Financing cash flows from sale leaseback	21	—	—
Right-of-use assets obtained in exchange for new lease obligations:			
Operating leases	34,313	64,660	29,549
Finance leases	3,842	478	18,991

Maturities of lease liabilities as of December 31, 2023 were as follows:

	<u>Operating Leases</u>	<u>Finance Leases</u>
2024	\$ 49,267	\$ 8,954
2025	42,647	8,937
2026	41,130	9,555
2027	33,239	8,344
2028	26,278	7,214
Thereafter	64,997	60,946
Total future minimum rental commitments	<u>257,558</u>	<u>103,950</u>
Less, amounts representing interest	<u>(38,680)</u>	<u>(30,468)</u>
Total lease liabilities	<u>\$ 218,878</u>	<u>\$ 73,482</u>

In the fourth quarter of 2023, a subsidiary of the Company entered into a purchase and sale agreement with a developer to sell one of the Company's owned supply chain center buildings and the associated land for \$14.9 million. Concurrently, a separate subsidiary of the Company entered into a lease agreement with the developer to construct a new supply chain center which includes both the existing building as well as an adjoined new construction on the adjacent properties owned by the developer.

The leaseback of the Company's building on a standalone basis for the construction period plus the 20-year term using the discount rate implicit in the lease resulted in a finance lease classification, and therefore, the transaction was accounted for as a failed sale leaseback. The Company retained the existing land and buildings on its consolidated balance sheet which are included in property, plant and equipment and the Company continues to depreciate the building as if it owned it. The \$14.9 million cash proceeds from the transaction were recorded as a financing obligation which is classified as long-term debt in the Company's consolidated balance sheet and will be amortized into principal and interest expense over the term of the lease agreement. The \$119.5 million of future minimum rent payments associated with the new construction on a standalone basis is included in the disclosure for material leases not yet commenced, below.

As of December 31, 2023, in addition to the lease for the new supply chain construction on a standalone basis discussed above, the Company also had additional leases for certain supply chain and U.S. Company-owned store vehicles that had not yet commenced. The total estimated future minimum rental commitments for all of these arrangements is \$146.3 million. These leases are expected to commence in 2024 and 2025 with lease terms of up to 20 years. These undiscounted amounts are not included in the table above.

The Company has guaranteed lease payments related to certain franchisees' lease arrangements. The maximum amount of potential future payments under these guarantees was \$18.5 million and \$24.5 million as of December 31, 2023 and January 1, 2023, respectively. The Company does not believe these arrangements have or are likely to have a material effect on its results of operations, financial condition, revenues or expenses, capital expenditures or liquidity.

(5) Commitments and Contingencies

The Company is a party to lawsuits, revenue agent reviews by taxing authorities and legal proceedings, of which the majority involve workers' compensation, employment practices liability, general liability and automobile and franchisee claims arising in the ordinary course of business. The Company records legal fees associated with loss contingencies when they are probable and reasonably estimable. Litigation is subject to many uncertainties, and the outcome of individual litigated matters is unpredictable. These matters could be decided unfavorably and could require the Company to pay damages or make other expenditures in amounts or a range of amounts that cannot be estimated with accuracy. However, the Company does not believe these matters, individually or in the aggregate, will have a material adverse effect on the business or financial condition of the Company, and the Company expects that the established accruals adequately provide for the estimated resolution of such claims.

(6) Income Taxes

The Parent files a consolidated Federal income tax return which includes the Company's operations. For financial reporting purposes, the Company accounts for income taxes as if it files its own consolidated Federal income tax return.

Income before provision for income taxes in 2023, 2022 and 2021 consisted of the following:

	<u>2023</u>	<u>2022</u>	<u>2021</u>
U.S.	\$ 640,255	\$ 560,115	\$ 611,267
Foreign	12,185	12,718	14,438
Income before provision for income taxes	<u>\$ 652,440</u>	<u>\$ 572,833</u>	<u>\$ 625,705</u>

The differences between the U.S. Federal statutory income tax provision (using the statutory rate of 21%) and the Company's consolidated provision for income taxes for 2023, 2022 and 2021 are summarized as follows:

	<u>2023</u>	<u>2022</u>	<u>2021</u>
Federal income tax provision based on the statutory rate	\$ 137,012	\$ 120,295	\$ 131,398
State and local income taxes, net of related Federal income taxes	19,473	15,978	15,108
Non-resident withholding and foreign income taxes	25,301	23,276	21,833
Foreign tax and other tax credits	(25,786)	(19,849)	(23,509)
Foreign derived intangible income	(17,850)	(15,068)	(16,800)
Excess tax benefits from equity-based compensation	(3,397)	(2,169)	(18,911)
Non-deductible expenses, net	5,040	3,322	4,501
Unrecognized tax provision (benefit), net of related Federal income taxes	16	(3,788)	4,372
Other	(6,487)	(1,427)	(2,754)
Provision for income taxes	<u>\$ 133,322</u>	<u>\$ 120,570</u>	<u>\$ 115,238</u>

Excess tax benefits from Parent equity-based compensation activity resulted in a decrease in the Company's provision for income taxes of \$3.4 million, \$2.2 million and \$18.9 million in 2023, 2022 and 2021, respectively, primarily due to the recognition of excess tax benefits for options exercised and the vesting of equity awards.

The components of the 2023, 2022 and 2021 consolidated provision for income taxes were as follows:

	<u>2023</u>	<u>2022</u>	<u>2021</u>
Provision for Federal income taxes			
Current provision	\$ 100,287	\$ 76,552	\$ 74,910
Deferred (benefit) provision	(16,467)	4,125	(2,051)
Total provision for Federal income taxes	83,820	80,677	72,859
Provision for state and local income taxes			
Current provision	27,243	20,489	16,507
Deferred (benefit) provision	(2,991)	577	(461)
Total provision for state and local income taxes	24,252	21,066	16,046
Provision for non-resident withholding and foreign income taxes			
Current provision	25,301	23,276	21,833
Deferred (benefit) provision	(51)	(4,449)	4,500
Total provision for non-resident withholding and foreign income taxes	25,250	18,827	26,333
Provision for income taxes	<u>\$ 133,322</u>	<u>\$ 120,570</u>	<u>\$ 115,238</u>

As of December 31, 2023 and January 1, 2023, the significant components of net deferred income taxes were as follows:

	<u>December 31, 2023</u>	<u>January 1, 2023</u>
Deferred income tax assets		
Operating lease liabilities	\$ 53,720	\$ 56,750
Accruals and reserves	16,176	11,330
Insurance reserves	12,592	13,039
Non-cash equity-based compensation expense	10,309	8,849
Foreign tax credit	16,798	13,464
Other	13,181	12,150
Deferred income tax assets before valuation allowance	<u>122,776</u>	<u>115,582</u>
Less, valuation allowance	<u>(18,166)</u>	<u>(15,001)</u>
Deferred income tax assets, net	<u>104,610</u>	<u>100,581</u>
Deferred income tax liabilities		
Operating lease right-of-use assets	50,883	54,057
Capitalized software	14,523	27,443
Depreciation, amortization and asset basis differences	12,155	15,851
Unrealized gain on investments	13,369	9,065
Deferred income tax liabilities	<u>90,930</u>	<u>106,416</u>
Net deferred income taxes	<u>\$ 13,680</u>	<u>\$ (5,835)</u>

Realization of the Company's deferred tax assets is dependent upon many factors, including, but not limited to, the Company's ability to generate sufficient taxable income. Although realization of the Company's deferred tax assets is not assured, on an ongoing basis, management assesses whether it remains more likely than not the deferred tax assets will be realized.

As of December 31, 2023 and January 1, 2023, the Company had total foreign tax credits of \$16.8 million and \$13.5 million, respectively, which were fully offset with a corresponding valuation allowance. As of December 31, 2023 and January 1, 2023, the Company also had valuation allowances related to interest deductibility in separately filed states of \$1.4 million and \$1.5 million, respectively. Management believes the remaining deferred tax assets will be realized. For financial reporting purposes, the Company's investment in foreign subsidiaries does not exceed its tax basis. Therefore, no deferred income taxes have been provided. In 2023 and 2021, the Company recorded certain unrealized gains on its non-controlling interest in DPC Dash as disclosed in Note 3, and accordingly, has also recorded a deferred tax liability representing the book basis over tax basis related to these unrealized gains.

The Company recognizes the financial statement benefit of a tax position if it is more likely than not that the position is sustainable, based solely on its technical merits and consideration of the relevant taxing authorities widely understood administrative practices and precedents. For tax positions meeting the "more likely than not" threshold, the amount recognized in the financial statements is the largest benefit that has a greater than 50 percent likelihood of being realized upon ultimate settlement with the relevant tax authority. The Company recognizes accrued interest related to unrecognized tax benefits in interest expense and recognizes penalties in income tax expense.

A reconciliation of the beginning and ending amount of unrecognized tax benefits as of December 31, 2023, January 1, 2023 and January 2, 2022 is as follows:

	<u>December 31, 2023</u>	<u>January 1, 2023</u>	<u>January 2, 2022</u>
Unrecognized tax benefits at beginning of period	\$ 3,902	\$ 7,690	\$ 3,318
Additions for tax positions of current year	961	887	2,611
Additions for tax positions of prior years	503	958	2,624
Reductions for changes in prior year tax positions	(551)	(4,521)	(379)
Reductions for lapses of applicable statute of limitations	(897)	(1,112)	(484)
Unrecognized tax benefits at end of period	<u>\$ 3,918</u>	<u>\$ 3,902</u>	<u>\$ 7,690</u>

As of December 31, 2023, the amount of unrecognized tax benefits was \$3.9 million of which, if ultimately recognized, \$3.9 million would be recognized as an income tax benefit and reduce the Company's effective tax rate. As of December 31, 2023, the Company had \$0.4 million of accrued interest and no accrued penalties.

As of January 1, 2023, the amount of unrecognized tax benefits was \$3.9 million of which, if ultimately recognized, \$3.6 million would be recognized as an income tax benefit and reduce the Company's effective tax rate. As of January 1, 2023, the Company had \$0.3 million of accrued interest and no accrued penalties.

There are currently no Internal Revenue Service audits in progress for the Company. The Company continues to be under examination by certain states. The Company's Federal statute of limitation has expired for years prior to 2020, but it varies for state and foreign locations. The Company believes appropriate provisions for all outstanding tax issues have been made for all jurisdictions and all open years.

(7) Employee Benefits

The Company has a retirement savings plan which qualifies under Internal Revenue Code Section 401(k). All employees of the Company who have completed 1,000 hours of service and are at least 18 years of age are eligible to participate in the plan. Beginning in fiscal 2024, employees aged 18 or older who have also worked at least 60 days for the Company will be eligible to participate in the plan. The plan requires the Company to match 100% of the first 5% of each employee's elective deferrals. The Company's matching contributions are made in the form of cash and vested immediately. The expenses incurred for Company contributions to the plan were \$12.5 million, \$12.4 million and \$12.9 million in 2023, 2022 and 2021, respectively.

The Company has established a non-qualified deferred compensation plan available for certain key employees. Under this self-funding plan, the participants may defer up to 40% of their base salary and up to 80% of their bonus compensation. The participants direct the investment of their deferred compensation within several investment funds. The Company is not required to contribute and did not contribute to this plan during 2023, 2022 and 2021.

The Parent has an employee stock payroll deduction plan (the "ESPDP"). Under the ESPDP, eligible employees may deduct up to 15% of their eligible wages to purchase the Parent's common stock at 85% of the market price of the stock at the purchase date. The ESPDP requires employees to hold their purchased common stock for at least one year. The Company purchases Parent common stock on the open market for the ESPDP at the current market price. There were 18,439 shares, 17,378 shares and 16,382 shares of Parent common stock in 2023, 2022 and 2021, respectively, purchased on the open market for participating employees at a weighted-average price of \$341.76 in 2023, \$391.23 in 2022 and \$424.90 in 2021. The expenses incurred under the ESPDP were \$0.9 million, \$1.0 million, and \$1.0 million in 2023, 2022 and 2021, respectively.

(8) Equity Incentive Plans

The Parent's current equity incentive plan, named the Domino's Pizza, Inc. 2004 Equity Incentive Plan (the "2004 Equity Incentive Plan"), benefits certain of the Company's employees and members of the Parent's Board of Directors. As of December 31, 2023, the maximum number of shares that may be granted under the 2004 Equity Incentive Plan is 15,600,000 shares of voting Parent common stock of which 2,172,419 shares were authorized for grant but have not been granted.

The cost of all employee Parent stock options, as well as other equity-based compensation arrangements, is reflected in the consolidated statements of income based on the estimated fair value of the awards and is amortized over the requisite service period of each award. All non-cash equity-based compensation expense amounts are recorded in general and administrative expense. The Parent accounts for forfeitures as they occur.

The Company recorded total non-cash equity-based compensation expense of \$37.5 million, \$28.7 million and \$28.7 million in 2023, 2022 and 2021, respectively. The Company recorded a deferred tax benefit related to non-cash equity-based compensation expense of \$6.3 million, \$4.9 million and \$4.3 million in 2023, 2022 and 2021, respectively.

Parent Stock Options

As of December 31, 2023, the number of Parent stock options granted and outstanding under the 2004 Equity Incentive Plan was 686,348 options. Parent stock options granted in fiscal 2014 through fiscal 2020 were granted with an exercise price equal to the market price at the date of the grant, expire ten years from the date of grant and generally vest over four years from the date of grant, generally subject to the holder's continued employment. Parent stock options granted after fiscal 2020 were granted with an exercise price equal to the market price at the date of the grant, expire ten years from the date of grant and generally vest over three years from the date of grant, generally subject to the holder's continued employment. Additionally, all stock options granted become fully exercisable upon vesting. These awards also contain provisions for accelerated vesting upon the retirement of holders that have achieved specific service and age requirements.

Parent stock option activity related to the 2004 Equity Incentive Plan is summarized as follows:

	Parent Stock Options			
	Outstanding	Weighted Average Exercise Price	Weighted Average Remaining Life (Years)	Aggregate Intrinsic Value (In thousands)
Stock options at January 3, 2021	832,666	\$ 160.82		
Stock options granted	42,742	367.79		
Stock options forfeited	(11,990)	333.61		
Stock options exercised	(199,301)	98.76		
Stock options at January 2, 2022	664,117	\$ 189.64		
Stock options granted	49,716	393.44		
Stock options forfeited or expired	(8,712)	375.23		
Stock options exercised	(32,979)	100.44		
Stock options at January 1, 2023	672,142	\$ 206.69		
Stock options granted	104,711	300.16		
Stock options forfeited or expired	(11,973)	351.89		
Stock options exercised	(78,532)	110.22		
Stock options at December 31, 2023	686,348	\$ 229.45	4.6	\$ 125,516
Exercisable at December 31, 2023	543,728	\$ 203.70	3.5	\$ 113,439

The total intrinsic value of Parent stock options exercised was \$19.6 million, \$8.8 million and \$77.4 million in 2023, 2022 and 2021, respectively. Cash received from the exercise of Parent stock options was \$8.7 million, \$3.3 million and \$19.7 million in 2023, 2022 and 2021, respectively. The tax benefit realized from Parent stock options exercised was \$4.2 million, \$1.9 million and \$17.6 million in 2023, 2022 and 2021, respectively.

The Company recorded total non-cash equity-based compensation expense of \$5.8 million, \$4.2 million and \$5.7 million in 2023, 2022 and 2021, respectively, related to Parent stock option awards. As of December 31, 2023, there was \$8.6 million of total unrecognized compensation cost related to unvested Parent stock options granted under the 2004 Equity Incentive Plan which generally will be recognized on a straight-line basis over the related vesting period. This unrecognized compensation cost is expected to be recognized over a weighted average period of 1.9 years.

Management estimated the fair value of each Parent option grant made during 2023, 2022 and 2021 as of the date of the grant using the Black-Scholes option pricing method. The risk-free interest rate is based on the estimated expected life and is estimated based on U.S. Treasury Bond rates as of the grant date. The expected life is based on several factors, including, among other things, the vesting term and contractual term as well as historical experience. The expected volatility is based principally on the historical volatility of the Parent's share price. Option valuation models require the input of highly subjective assumptions and changes in assumptions can significantly affect the estimated fair value of the Parent's stock options.

The weighted average assumptions used in estimating the fair value of each Parent stock option granted in 2023, 2022 and 2021 using the Black-Scholes option pricing method are presented in the following table:

	2023	2022	2021
Risk-free interest rate	4.0%	2.0%	1.0%
Expected life	5.25 years	5.25 years	5.25 years
Expected volatility	32.0%	31.0%	30.0%
Expected dividend yield	1.6%	1.1%	1.0%
Weighted average fair value per stock option	\$ 91.25	\$ 109.05	\$ 93.46

Other Equity-Based Compensation Arrangements

The Parent granted 4,553 units, 3,792 shares and 3,292 shares of restricted stock in 2023, 2022 and 2021, respectively, to members of the Parent's Board of Directors. Restricted stock units and awards granted to members of the Parent's Board of Directors were granted with a fair value equal to the market price of the Parent's common stock on the grant date and generally vest one year from the date of grant, generally subject to the director's continued service. These awards also contain provisions for accelerated vesting upon the retirement eligibility of holders that have achieved specified service and age requirements. The Company recorded total non-cash equity-based compensation expense of \$1.6 million in 2023 and \$1.4 million in each of 2022 and 2021, related to these restricted stock grants. As of December 31, 2023, there was \$0.1 million of total unrecognized compensation cost related to these restricted stock grants.

The Parent granted 125,285 units, 81,739 units and 49,963 units of restricted stock in 2023, 2022 and 2021, respectively, to certain employees of the Company. These restricted stock units were granted with a fair value equal to the market price of the Parent's common stock on the grant date. These restricted stock units are generally separated into three tranches and have time-based vesting conditions with the last tranche of the award vesting three years from the grant date, generally subject to the holder's continued employment. These awards generally also contain provisions for accelerated vesting upon the retirement of holders that have achieved specified service and age requirements. The Company recorded total non-cash equity-based compensation expense of \$14.1 million, \$11.1 million and \$5.4 million in 2023 and 2022, respectively, related to these restricted stock units. As of December 31, 2023, there was \$24.9 million of total unrecognized compensation cost related to these restricted stock units.

The Parent granted 37,677 units, 8,921 units and 6,546 units of performance-based restricted stock in 2023, 2022 and 2021, respectively, to certain employees of the Company. These restricted stock units were granted with a fair value equal to the market price of the Parent's common stock on the grant date, certain of which were adjusted for the estimated fair value of the market condition included in the award. These performance-based restricted stock units may vest three years from the date of grant, generally subject to the holder's continued employment, and have time- and performance-based vesting conditions which provide for potential payouts of the target award amount between zero percent and two hundred percent, based on the Parent's three-year achievement as compared to the specified target performance conditions. Certain of the performance-based restricted stock units also include provisions for a potential modifier (upward or downward) based on the Parent's cumulative three-year common stock total shareholder return performance relative to that of a pre-established peer group. These awards contain provisions for full or partial vesting if holder retires during the performance period, after achieving specified service and age requirements. For the awards with a market condition, Management estimated the fair value of each performance-based restricted stock unit using a Monte-Carlo simulation pricing method. The risk-free interest rate is based on the estimated expected life and is estimated based on U.S. Treasury Bond rates as of the grant date. The Monte-Carlo simulation also includes assumptions for expected volatility based principally on the historical volatility of the Parent's share price, as well as the correlation of the Parent's share price as compared to that of the pre-established peer group. The Company recorded total non-cash equity-based compensation expense of \$12.8 million, \$3.4 million and \$1.4 million in 2023, 2022 and 2021, respectively, related to these performance-based restricted stock units. As of December 31, 2023, there was \$24.2 million of total estimated unrecognized compensation cost based on current attainment projections related to these performance-based restricted stock units.

The weighted average assumptions used in estimating the fair value of the performance-based restricted stock units granted in 2023, 2022 and 2021 that include a market condition using the Monte-Carlo simulation pricing method are presented in the following table:

	<u>2023</u>	<u>2022</u>	<u>2021</u>
Risk-free interest rate	4.3%	1.9%	0.3%
Expected life	2.80 years	2.81 years	2.75 years
Expected volatility	30.2%	33.2%	33.9%
Weighted average fair value per performance-based restricted stock unit \$	306.19	\$ 396.87	\$ 375.85

The Parent previously granted performance-based restricted stock to certain employees of the Company. These performance-based restricted stock awards are separated into four tranches and have time-based and performance-based vesting conditions with the last tranche vesting four years from the issuance date, generally subject to the holder's continued employment. These awards contain provisions for full or partial vesting if holder retires during the performance period, after achieving specified service and age requirements. These awards were considered granted for accounting purposes when the performance target was established, which was generally in the fourth quarter of each year. The Company recorded total non-cash equity-based compensation expense of \$3.2 million, \$8.0 million and \$12.7 million in 2023, 2022 and 2021, respectively, related to these awards. As of December 31, 2023, there was an estimated \$0.5 million of total unrecognized compensation cost related to performance-based restricted stock.

In 2018, the Parent granted 28,570 shares of restricted stock to two executives of the Company. These awards had a fair value equal to the market price of the Parent's common stock on the grant date and vested in 2022, four years from the date of the grant. The Company recorded total non-cash equity-based compensation expense of \$0.6 million in 2022 and \$2.1 million in 2021 related to these restricted stock awards.

Activity related to restricted stock awards and units and performance-based restricted stock awards and units awarded under the 2004 Equity Incentive Plan is summarized as follows in the table below. The unrecognized compensation cost related to restricted stock awards and units and performance-based restricted stock awards and units is expected to be recognized over a weighted average period of 2.3 years.

	Shares	Weighted Average Grant Date Fair Value
Nonvested at January 3, 2021	146,762	\$ 304.69
Shares granted	59,801	382.79
Shares forfeited	(12,924)	340.94
Shares vested	(48,378)	287.41
Nonvested at January 2, 2022	145,261	\$ 339.37
Shares granted	94,452	389.49
Shares forfeited	(18,563)	375.36
Shares vested	(75,506)	312.90
Nonvested at January 1, 2023	145,644	\$ 381.00
Shares granted	167,515	315.51
Shares forfeited	(9,799)	354.44
Shares vested	(54,225)	368.41
Nonvested at December 31, 2023	<u>249,135</u>	<u>\$ 341.86</u>

(9) Company-owned Store Transactions

During the first quarter of 2023, the Company refranchised one U.S. Company-owned store for proceeds of less than \$0.1 million. The pre-tax refranchising loss associated with the sale of the related assets and liabilities, including goodwill, was approximately \$0.1 million and was recorded in refranchising loss in the Company's consolidated statements of income.

During 2022, the Company purchased 23 U.S. franchised stores in Michigan from certain of the Company's existing U.S. franchisees for \$6.8 million, which included \$4.0 million of intangibles, \$1.7 million of equipment and leasehold improvements and \$1.1 million of goodwill.

Also during 2022, the Company refranchised 114 U.S. Company-owned stores in Arizona and Utah for proceeds of \$41.1 million. In connection with the refranchising of the stores, the Company recorded a \$21.2 million pre-tax gain on the sale of the related assets and liabilities, including a \$4.3 million reduction in goodwill. The net gain on the sale of these stores was recorded in refranchising gain in the Company's consolidated statements of income.

EXHIBIT E

TRADITIONAL STORE STANDARD FRANCHISE AGREEMENT

Store #

**DOMINO'S PIZZA FRANCHISING LLC
STANDARD FRANCHISE AGREEMENT**

Franchisee

[THIS PAGE INTENTIONALLY LEFT BLANK]

TABLE OF CONTENTS

	<u>Page</u>
1. INTRODUCTION	7
2. GRANT AND TERM OF FRANCHISE.....	8
2.1 Grant	8
2.2 Term of Franchise	8
3. RENEWAL OF FRANCHISE.....	8
3.1 Option to Renew	8
3.2 Manner of Renewal.....	9
3.3 Notification of Expiration	9
4. TERRITORIAL RIGHTS AND OBLIGATIONS	10
4.1 Area of Primary Responsibility	10
4.2 Delivery Service.....	10
4.3 Exclusions	10
5. OPENING ADVERTISING AND PROMOTION EXPENDITURE	11
6. ROYALTY FEE AND OTHER CHARGES.....	11
6.1 Amount and Payment.....	11
6.2 Definition of Royalty Sales.....	11
6.3 Interest on Late Payments	11
6.4 Electronic Funds Transfer.....	11
6.5 Application of Payments.....	12
7. STORE LOCATION	12
7.1 Location and Use	12
7.2 Relocation; Damage, or Condemnation	12
7.3 Location and Operation of Commissary.....	13
7.4 Store Lease.....	13
7.5 Assumption of Lease on Termination or Expiration.....	13
7.6 Ownership of Store Premises.....	13
8. STORE DEVELOPMENT	14
8.1 Development and Construction.....	14
8.2 Equipment, Fixtures, Furniture and Signs	14

8.3	Store Opening	15
9.	STORE REFURBISHING	15
10.	TRAINING	16
10.1	Initial Training	16
10.2	Training of Employees.....	16
10.3	Additional Training.....	16
11.	OPERATING ASSISTANCE.....	16
11.1	Advice and Guidance.....	16
11.2	Operating Problems	17
12.	STORE PRODUCTS	17
12.1	Store Menu.....	17
12.2	Pizza Ingredients, Supplies and Materials	17
13.	ADVERTISING AND PROMOTION	18
13.1	By DPF.....	18
13.2	Local and Regional Advertising Cooperatives	19
13.3	By Franchisee.....	20
14.	RECORDS AND REPORTS.....	20
14.1	Bookkeeping and Recordkeeping	20
14.2	Sales Reports and Financial Statements	21
14.3	Right to Require Audit.....	22
15.	OPERATING REQUIREMENTS	23
15.1	Operating Procedures.....	23
15.2	Compliance with Laws and Other Business Practices.....	24
15.3	Pricing.....	25
15.4	Operating Manual	25
15.5	New Concepts	25
15.6	Franchisee Must Directly Supervise Store.....	25
15.7	Insurance.....	26
15.8	Identification as Franchisee	27
15.9	Computer Hardware and Software and Other Technology.....	27
15.9.1	Brand Technology.....	27
15.9.2	Aggregate Expenditures for Brand Technology	28
15.9.3	Domino's PULSE and Other Computer & Technology Training	29

	15.9.4 Additional Order Processing Systems	29
16.	MARKS	30
	16.1 Usage.....	30
	16.2 Infringements	30
	16.3 Indemnification.....	30
17.	INSPECTIONS	30
18.	TERMINATION AND EXPIRATION	31
	18.1 Termination By Franchisee.....	31
	18.2.1 Immediate Termination By DPF - Upon Written Notice.....	31
	18.2.2 Termination By DPF - After Opportunity to Cure.....	33
	18.2.3 Immediate Cessation of Operations	33
	18.3 Obligations Upon Termination or Expiration	33
19.	OPTION TO PURCHASE STORE	34
	19.1 Option	34
	19.2 Formula Price.....	35
	19.3 Purchase of Commissary.....	35
	19.4 Deductions From Purchase Price	35
	19.5 Payment of Purchase Price.....	36
	19.6 Real Property	36
	19.7 Closing	37
	19.8 Operation During Option Period.....	37
	19.9 Formula Price.....	37
20.	RESTRICTIVE COVENANTS.....	38
	20.1 In-Term Covenant.....	38
	20.2 Post-Term Covenant	38
	20.3 Ownership of Public Companies	38
	20.4 Customer Lists and Trade Secrets.....	38
	20.5 Owners of Approved Entity	39
	20.6 Distribution of Products Related to the Domino's System	39
	20.7 Ownership Structure	39
	20.8 Non-Disclosure	39
	20.9 Irreparable Injury and Injunctive Relief	39

21.	ASSIGNMENT.....	40
21.1	By DPF.....	40
21.2	By Franchisee.....	40
21.3	Assignment to an Approved Entity.....	40
21.4	Assignment or Transfer to Others.....	41
21.5	Death or Permanent Disability.....	42
21.6	Definition of Permanent Disability.....	42
21.7	Operation by DPF After Death or Permanent Disability.....	42
21.8	Right of First Refusal of DPF.....	43
22.	CONTRACT INTERPRETATION AND ENFORCEMENT.....	43
22.1	Effect of Waivers.....	43
22.2	Cost of Enforcement.....	44
22.3	Indemnification of DPF.....	44
22.4	Construction and Severability.....	44
22.5	Scope and Modification of Agreement.....	45
22.6	Governing Law.....	45
22.7	Notices.....	45
22.8	Independent Contractors.....	46
22.9	Standard of Reasonableness.....	46
22.10	Acknowledgments.....	46
22.11	Binding Effect.....	47
22.12	No Waiver or Disclaimer of Reliance in Certain States.....	47
22.13	Effective Date of this Agreement.....	47

DOMINO'S PIZZA FRANCHISING LLC
STANDARD FRANCHISE AGREEMENT

This Standard Franchise Agreement, including the Covenants of Owners (this "Agreement") is being entered into between Domino's Pizza Franchising LLC, a Delaware limited liability company ("we", "DPF" or "us" in this Agreement), and

("you" or "franchisee" in this Agreement). If you are a corporation, partnership, limited liability company or other entity approved by us to own a Domino's Pizza Store (the "Approved Entity"), the term "owners" in this Agreement shall refer to your shareholders, affiliates, partners, members or other interest holders. Unless otherwise approved by DPF, the term "Controlling Person" refers to the person who owns fifty-one percent (51%) or more of: the general partnership interest of such partnership; the equity and voting power of all classes of the issued and outstanding capital stock of such corporation; the membership interests of such limited liability company or the voting and ownership interests of such other entity.

1. INTRODUCTION.

We are in the business of franchising retail outlets specializing in the sale of pizza and other authorized food and beverage products and featuring carry-out and delivery services. These outlets are known as "Domino's Pizza" stores and conduct business under a uniform business format, with specially designed equipment, computer hardware and software designated by us, and specifications for the preparation and sale of pizza and certain authorized food products (the "Domino's System"). We have obtained the license to use and the right to sublicense the use of certain valuable trademarks, service marks and commercial symbols in connection with the operation of Domino's Pizza Stores including the mark "Domino's Pizza" (the "Marks").

You have applied to us for a franchise to operate a Domino's Pizza Store utilizing the Domino's System and the Marks at the location identified in this Agreement. Your application has been approved by us in reliance upon all of the representations made in your application including those concerning your financial resources, your other investments and interests and the manner in which the franchise will be owned and operated.

You understand and agree that the terms and conditions contained in this Agreement are necessary to maintain our high standards of quality and service and the uniformity of those standards at all Domino's Pizza Stores.

2. GRANT AND TERM OF FRANCHISE.

2.1 Grant.

Subject to the terms of this Agreement, DPF grants to you a franchise to operate a Domino's Pizza Store (the "Store") under the Domino's System and a sublicense to use the Marks in the operation of the Store at the following location: Domino's Pizza Store # located at:

2.2 Term of Franchise.

The term of this Agreement shall be for a period of ten (10) years, commencing on the date of opening of the Store (or if this Agreement is being signed in connection with a renewal or transfer of the franchise, commencing on the day following the expiration or termination of the previous franchise agreement, as the case may be).

3. RENEWAL OF FRANCHISE.

3.1 Option to Renew.

You may, at your option, renew the franchise for one additional ten (10) year term by signing a new franchise agreement with us, provided:

(a) you are not in material default of any provision of this Agreement or any other agreement with us or our subsidiaries or affiliates or any other creditor or supplier of the Store and have substantially complied with the terms and conditions of these agreements during their terms. For purposes of this Section 3.1(a), "substantial compliance" shall mean that you have not (i) breached or violated the terms of this Agreement on six (6) or more occasions during the term of this Agreement or on three (3) or more occasions during the last twenty four (24) months prior to the expiration of the term of this Agreement regardless of whether or not you cured any such breach or violation, or (ii) engaged in any conduct or act described in Section 18.2.1 of this Agreement at any time during the term of this Agreement regardless of whether or not you cured any such breach or violation;

(b) you are able to maintain possession of the Store premises or to secure and develop a suitable alternative site approved by us;

(c) you refurbish the site as provided in Sections 9 and 15 of this Agreement or, if we require, agree to relocate the premises of the Store to a location approved by us and develop the premises in accordance with our then current requirements. If we require you to relocate the premises of the Store, you will be entitled to credit the costs of developing the new premises toward any refurbishing obligations you may have under the franchise agreement executed in connection with such renewal; and

(d) subject to applicable laws, you and your owners agree to execute a general release, in a form then prescribed by us, of any claims arising out of this Agreement against us and our affiliates, and our and their officers, directors, managers, agents, representatives and employees. This option to renew may not be exercised unless all of the preceding conditions are fully satisfied. The option to renew is personal to you and may not be exercised by any other person or entity without our prior written consent.

3.2 Manner of Renewal.

The new franchise agreement you must execute to renew the franchise shall be our then current form of standard franchise agreement. You must also sign all other agreements we customarily require at the time of renewal of the franchise. You understand that the renewal franchise agreement may provide for higher royalty fees and greater expenditures for advertising and promotion than are provided for in this Agreement and may contain other terms materially different from the terms of this Agreement. The area of primary responsibility of the Store will not be modified unless such modification is consistent with criteria then in effect for comparable market areas. There will be no initial franchise or similar fee charged upon a renewal of the franchise. You will also be entitled to renew the franchise at the end of the renewal term in accordance with the renewal provisions, if any, contained in the franchise agreement executed by you in connection with your renewal of the franchise.

3.3 Notification of Expiration.

Provided you are in compliance with this Agreement, including the provisions of Section 3.1, we will send all agreements relating to renewal of the franchise for your review and execution approximately six (6) months prior to the expiration of this Agreement along with a notification of the expiration of this Agreement. Your failure to return these agreements to us within thirty (30) days of receipt will be deemed an election by you not to renew this Agreement. Our notice will also state what actions, if any, you must take to correct the deficiencies in your operation of the Store or whether we will require you to relocate or refurbish the premises of the Store as provided in Section 3.1 above. We also will specify the time period in which these deficiencies must be corrected or by which the refurbishing or relocation and development of the new premises must be completed, provided that, in the event that the then current term of your lease or any renewal lease does not expire concurrently with the expiration of this Agreement, we will not require you to complete a relocation of your Store and development of the new premises until the expiration of the then current term of your lease or any renewal lease. If we require you to relocate the Store, our notice will identify the reasons for requiring relocation. Renewal of the franchise will be conditioned on your continued compliance with all the terms and conditions of this Agreement and all other agreements with us and our affiliates and subsidiaries and all other creditors and suppliers of the Store up to the date of expiration.

4. TERRITORIAL RIGHTS AND OBLIGATIONS.

4.1 Area of Primary Responsibility.

The following geographic territory will be your Area of Primary Responsibility:

A one (1) mile radius from the store located at:

Provided you are in compliance with the terms of this Agreement, and except as otherwise provided in Section 4.3, we will not operate or grant a franchise for the operation of a Domino's Pizza Store during the term of this Agreement whose area of primary responsibility overlaps your Area of Primary Responsibility.

4.2 Delivery Service.

We shall have the right to prescribe from time to time the boundaries outside of which the Store may not offer delivery service. You further understand that in revising these boundaries we may in our discretion make adjustments to the size of your delivery and service area to account for, among other things, changing market conditions, population changes and other relevant considerations, including but not limited to the reasons contained in Section 4.3. You further agree that the Store will at all times during approved hours of operation offer delivery service to all customers located within your delivery and service area, provided, however, you are not required to offer delivery service in areas which might present a danger to you or your employees. However, you will remain solely responsible for investigating and reviewing periodically, but not less than annually, any decisions by you to limit your delivery area for safety reasons, subject to procedures and standards we may prescribe from time to time, and for obtaining and maintaining information that supports your decisions to limit delivery service. You understand and agree that you may not change the boundaries of your delivery and service area without our prior written consent. When making deliveries, you and your employees must strictly comply with all laws, regulations and rules of the road and due care and caution in the operation of delivery vehicles.

4.3 Exclusions.

Notwithstanding the provisions of Sections 4.1 and 4.2, enclosed malls, institutions (such as hospitals), airports, parks (including theme parks), sports arenas, convention centers and other facilities or venues where events are scheduled shall be excluded from your Area of Primary Responsibility and your delivery and service area, unless otherwise specified by us in writing. We retain the right on our behalf and behalf of our affiliates to open a Domino's Pizza store at any of these facilities or venues wherever the facility or venue is located, in order to service the facility or venue, or grant franchises or licenses for others to do so; provided, however, that you shall have the first option to operate the store and to service such facility or venue if you meet the legal and/or venue requirements, subject to your completion of our approval process and satisfaction of our conditions for approval. You shall be granted a reasonable period of time to consider the option. "Reasonable" shall be defined on a case-by-case basis by reference to the time allowed by the venue and competitive circumstances. In the event we decide to open a Domino's Pizza store at any of these facilities or venues; or grant a franchise or license for others to do so, the delivery and service area of the Store shall be automatically adjusted to exclude such facility or venue.

5. OPENING ADVERTISING AND PROMOTION EXPENDITURE.

If you (or the Controlling Person if you are an Approved Entity) are opening your (or his or her) first Domino's Pizza Store, you must submit to us proof no later than ninety (90) days after opening of the Store that you have spent at least Three Thousand Dollars (\$3,000.00) on grand opening advertising and promotion.

6. ROYALTY FEE AND OTHER CHARGES.

6.1 Amount and Payment.

During the term of the franchise, you agree to pay us a royalty fee of five and one-half percent (5-1/2%) of the weekly royalty sales of the Store. This fee must be paid by Thursday of each week on royalty sales for the week ending on the preceding Sunday. Payment must be made by electronic funds transfer as provided in Section 6.4 below or as we may otherwise designate from time to time.

6.2 Definition of Royalty Sales.

The term "royalty sales" means the total receipts from all sales by the Store of all pizza, beverages and other products or services authorized for sale at the Store or at any approved off-site location but exclusive of sales or equivalent taxes, coupon and similar discounts, and beverage container deposits approved by us. Premium or similar promotional items must be included in computing royalty sales unless these items have been sold at or below cost by the Store. Premium or similar promotional items shall not be deemed to include any food or beverage item unless otherwise specified by us.

6.3 Interest on Late Payments.

All royalty fees, advertising contributions and all other amounts owed to us pursuant to this Agreement will bear interest after the due date at the rate of one and one-half percent (1½%) per month or at the highest legal rate for open account business credit in the state in which the Store is located, whichever is lower.

6.4 Electronic Funds Transfer.

You must participate in an electronic funds transfer program under which royalty fees and advertising contribution payments are deducted or paid electronically from your bank account. We may permit you to initiate payments via a system established or approved by us, or at our option, require you to authorize us to initiate debit and/or credit entries and/or credit correction entries to your Store bank operating account (the "Account") for payment of royalty fees and advertising contributions on forms we prescribe. In the event you are required to authorize us to initiate debit entries, you agree to make the funds available in the Account for withdrawal by electronic transfer no later than the due date for payment. The amount actually transferred from the Account to pay royalty fees and advertising contributions will be based on the Store's royalty sales reported to us. If you have not reported royalty sales of the Store to us for any reporting period, we will be authorized to debit the Account in an amount equal to the royalty fee transferred

from the Account for the last reporting period for which a report of the royalty sales of the Store was provided to us. If at any time we determine that you have under-reported the royalty sales of the Store or underpaid royalty fees or advertising contributions due us under this Agreement, we will be authorized to initiate immediately a debit to the Account in the appropriate amount in accordance with the foregoing procedure, including interest as provided for in this Agreement. An overpayment will be credited to the Account through a credit effective as of the first reporting date after we and you determine that such credit is due. Our use of electronic funds transfers as a method of collecting royalty fees and advertising contributions due us does not constitute a waiver of any of your obligations to provide us with weekly sales reports as provided in Section 14.2 nor shall it be deemed a waiver of any of the rights and remedies available to us under this Agreement. If, for any reason other than your fault or neglect, the electronic funds transfer program in which we require you to participate is not functioning so as to allow you to pay the amounts due under this Agreement to us, you may seek permission from us to make payment by mail for the period of time that the electronic funds transfer system is not functioning. If we grant permission for you to make payment by mail, we will specify the day by which payment must be postmarked and paid for any week on royalty sales for the week ending on the preceding Sunday.

6.5 Application of Payments.

When we receive a payment from you, we have the right in our sole discretion to apply it as we see fit to any past due indebtedness of yours due to us or our affiliates, whether for royalties, advertising contributions, purchases, interest, or for any other reason, regardless of how you may designate a particular payment to be applied. In addition, we may offset any amount otherwise due under any discount or rebate program against any amount owed to us.

7. STORE LOCATION.

7.1 Location and Use.

You may operate the Store only at the location specified in Section 2.1 and you may not relocate the Store except with our prior written consent. The Store may only be used for the operation of a Domino's Pizza Store and other related activities approved by us in writing. You shall not allow the premises of the Store to be used for any purpose which in our judgment, adversely affects the reputation of the Store or the goodwill associated with the Marks or involves dishonesty, fraud, deceit, illegal conduct, misrepresentation, or moral turpitude.

7.2 Relocation; Damage, or Condemnation.

In the event the Store is destroyed or rendered unusable, we may grant permission for the Store to be repaired, restored or reconstructed at the existing location or any other agreed upon location. Any repair, restoration, reconstruction or relocation will be at your sole expense. The Store, whether we grant permission for you to repair, restore, reconstruct or relocate, must be open and operating no later than six (6) months after its closure. In addition, within ten (10) days of vacating the Store premises, you must make such reasonable modifications to the exterior and interior of the Store (including signage, menu boards, job aids, product photos and the like) as we require to fully eliminate its identification and appearance as a Domino's Pizza Store. If you fail or refuse to fully de-identify the Store to the extent and in the manner required by this Agreement,

we may, at our option and in addition to other rights and remedies we may have, make the modifications that are contemplated by this Agreement on your behalf and you agree to promptly pay and reimburse us on demand for any costs incurred by us including, without limitation, the proportionate compensation of our employees who devote time and render services in the de-identification of the Store.

7.3 Location and Operation of Commissary.

Any commissary operated by you in connection with the Store may be located only at the premises of the Store or other premises approved by us in writing and must be operated in accordance with commissary standards prescribed by us from time to time. Such commissary must be owned by you and operated by you and your employees exclusively for the benefit of the Store or other Domino's Pizza Stores owned by you and may not be owned or operated by any other person or entity without our prior written consent. You may not open or operate a commissary unless you have received prior written notification from us that you have satisfied in advance all of our requirements for the operation of a commissary, including all required training of commissary personnel.

7.4 Store Lease.

Unless otherwise agreed to by us in writing, if the property on which the Store is located is not owned by you, you must maintain a lease for the site of the Store (including the lease for the site of the commissary, if any, to be operated by you in connection with the Store) which shall contain such terms as we specify from time to time for all leases of a similar type. Each original lease, renewal leases, and lease addenda and modification of any type must be submitted to us prior to execution for our examination and approval that it contains the terms we require in all leases. You must provide us with a copy of the executed lease, any renewal lease, and any addenda and modification within thirty (30) days after execution by you and the landlord.

7.5 Assumption of Lease on Termination or Expiration.

Upon the termination or expiration of the franchise for any reason, other than a termination by you for cause, we or our designee shall have the right to assume your status and replace you as lessee. You agree to execute an assignment of your interest in the lease promptly upon our request. Upon exercise of our right to assume, your status as lessee, and your compliance with the other provisions of this section, you will be fully released and discharged from all liability for rent and all other future liability under the lease (although not from any liability for unpaid rent or any other then existing liability to the lessor under the lease, including, without limitation, any damages to the premises or restoration costs). If we exercise our right to assume your lease, we will indemnify you and hold you harmless against any claim made for future rent or other future liability under the lease. We will also notify you within ninety (90) days of obtaining your written assignment of your interest in the lease of any damages to the premise or restoration costs for which you are liable or responsible.

7.6 Ownership of Store Premises.

If you, or any entity that you own or control, owns any interest in the real estate where

the Store is located, you agree to furnish to us upon request, a copy of the deed and any other document relating to the title to the real estate and a copy of your owner's policy of title insurance.

8. STORE DEVELOPMENT.

8.1 Development and Construction.

You agree that promptly after obtaining possession of the site for the Store you will:

(a) cause to be prepared and submit for approval by us a site plan and any modifications to our basic architectural plans and specifications for the Store, including requirements for dimensions, exterior design, materials, interior layout, equipment, fixtures, furniture, signs, and decorating. You understand that you may modify our basic plans and specifications only to the extent required to comply with applicable ordinances, building codes and permit requirements and only with our prior written approval;

(b) obtain all required zoning changes; all required building, driveway, utility, health, sanitation, and sign permits and any other required permits;

(c) purchase or lease fixtures, furniture and signs meeting our specifications or requirements and, if we so require, from an approved vendor or vendors designated by us;

(d) acquire through purchase, lease and/or license the Brand Technology as required by Section 15.9.1.

(e) complete the construction and/or remodeling, equipment, fixture, furniture and sign installation and decorating of the Store in full and strict compliance with plans and specifications approved by us and all applicable ordinances, building codes and permit requirements;

(f) obtain all customary contractors' sworn statements and partial and final waivers of lien for construction, remodeling, decorating and installation services; and,

(g) fully investigate and become familiar with the Store's delivery area and its boundaries.

8.2 Equipment, Fixtures, Furniture and Signs.

We will provide you with specifications for pizza, other authorized food and beverage preparation, dispensing, storage and display equipment, delivery and related motor vehicles, other equipment, fixtures, furniture, exterior and interior signs and decorating that we require you to use or install in the Store. We may specify brands, types or models for any of these items. You may purchase items meeting our specifications from any source unless we designate an approved source or sources for any of these items. If you propose to purchase or lease items not previously approved by us as meeting our specifications or from a vendor not approved by us, you must first notify us and we may require submission of sufficient specifications, photographs, drawings and/or other information and samples to determine whether any such item or supplier meets our

specifications or our approved vendor criteria. We will advise you within a reasonable time whether any proposed item or vendor meets our specifications or our approved vendor criteria. You agree to use only such items that meet our specifications in the operation of the Store and to purchase them from approved vendors, if we so require. You understand, however, that we or our affiliates or an approved vendor may be the only source for some of these items and that we may otherwise limit the number of approved vendors. We reserve the right to charge you for our reasonable expenses in testing and/or evaluating any proposed item or vendor submitted by you.

8.3 Store Opening.

You agree to complete development of the Store and have the Store ready to open within a reasonable time after obtaining possession of the site for the Store. If you do not open the Store within six (6) months from the effective date of this Agreement, we will have the option to terminate this Agreement upon the giving of written notice to you.

9. STORE REFURBISHING.

You have an obligation to maintain the Store in a manner which contributes positively to the then current image of the Domino's Pizza brand. You agree to refurbish the Store (in addition to regular maintenance and repair), within six (6) months of receipt of written notice from us, as we may from time to time require to maintain or improve the appearance and efficient operation of the Store, to increase its sales potential or to comply with our then current standards, image or identity. Refurbishing may include:

- (a) replacement of worn out or obsolete equipment, fixtures, furniture and signs;
- (b) the substitution or addition of new or improved equipment, including safes, fixtures, furniture, and signs, designated by us;
- (c) redecorating;
- (d) renovation of the interior and exterior of the premises and restoration and resurfacing of parking facilities; and
- (e) structural modifications and remodeling of the premises.

You will not be required to make aggregate expenditures for refurbishing of the Store in excess of one and one half percent (1 ½ %) of the royalty sales of the Store from the date of its opening to the date of any required refurbishing not to exceed the ten (10) year period prior to the date of any such required refurbishing or, except in connection with a renewal of the franchise, to effect any refurbishing of the Store during the last twelve (12) months of the initial term of the franchise.

For purposes of this Section 9, the term equipment shall not include computer hardware or other components of the Brand Technology (as defined in Section 15.9.1). Any additions, substitutions, replacements or modifications to the Brand Technology shall be governed by the provisions of Sections 15.9.1. and 15.9.2 of this Agreement.

10. TRAINING.

10.1 Initial Training.

If you (or the Controlling Person if you are an Approved Entity) are opening your (or his or her) first Domino's Pizza Store, you (or the Controlling Person) must enroll in and complete all training programs and classes which we require for the operation of a Domino's Pizza Store. These training programs and classes will be furnished at such times and places as we designate. We have the right to charge a reasonable training fee for these training programs or classes. All training programs and classes must be completed to our satisfaction. You will be responsible for the travel, living expenses and any other costs incurred during these training programs and classes.

10.2 Training of Employees.

You agree to implement a training program for employees of the Store and to be solely responsible for training the employees to legally, safely and properly perform his or her duties while inside the Store and while outside the Store for business purposes, including training your employees to follow appropriate procedures for their safety and well-being as well as the safety and well-being of the public. You agree not to employ any person who fails or refuses to complete your training programs or is unqualified to perform his or her duties in accordance with the requirements established for the operation of a Domino's Pizza Store. You acknowledge and understand that implementing a training program for employees of the Store and training your employees to follow safe and proper procedures for the operation of the Store will remain your sole responsibility even if, from time to time, you obtain advice, certifications or suggestions from us or our affiliates about these topics. You further acknowledge and understand that it is not our responsibility or duty to implement a training program for your employees, nor do we have the responsibility or duty to instruct your employees about matters of safety and security in or around the Store or delivery service area or on the way to or from the Store. By providing advice, certifications or suggestions, we do not assume any of your responsibilities or duties.

10.3 Additional Training.

We may also, at our option, require you (or the Controlling Person if you are an Approved Entity) to attend supplemental or additional training programs which may be offered from time to time by us or our affiliates during the term of the franchise. The fee for such training shall range from between One Hundred Dollars (\$100.00) and Five Hundred Dollars (\$500.00) per training class. You will be responsible for the reasonable costs of such programs and for the travel and living expenses and any other costs incurred during these programs. You must complete this supplemental or additional training within one (1) year of the time in which it is originally offered by us or our affiliates.

11. OPERATING ASSISTANCE.

11.1 Advice and Guidance.

We will furnish you with such reasonable operating assistance as we determine from time to time to be necessary for the operation of the Store. Operating assistance will include advice and guidance regarding:

(a) methods of pizza, other authorized food and beverage preparation, packaging and sale; and

(b) the establishment of administrative, bookkeeping, accounting, inventory control and general operating procedures.

You acknowledge and understand that it is not our responsibility or duty to operate the Store and we do not have the legal right to direct your employees in the operation of the Store. Those functions remain your sole responsibility and duty. Further, you understand that the assistance provided to you under this Section 11 does not obligate us to provide the accounting, bookkeeping, administrative, inventory control or marketing services required for the operation of the Store or to otherwise operate the Store. By providing advice or suggestions, we do not assume any of your responsibilities or duties.

11.2 Operating Problems.

We will advise you from time to time of operating problems of the Store disclosed by reports submitted to or inspections made by us or our designee. We will make no separate charge for operating or marketing assistance except that we may make reasonable charges for forms and other materials supplied to you and for operating assistance made necessary in our judgment as a result of your failure to comply with any provision of this Agreement or for operating assistance requested by you in excess of that normally provided by us. By providing advice, certifications or suggestions, we do not assume any of your responsibilities or duties.

12. STORE PRODUCTS.

12.1 Store Menu.

You agree that you will offer for sale and sell at the Store for final consumption and not for resale, all pizza and other authorized food and beverage products and perform the carry-out and delivery services that we from time to time authorize; provided, however, you may offer for resale authorized products for certain programs approved by us. Such approval will not be unreasonably withheld and the decision to approve shall be based upon: (i) quality assurance; (ii) brand image; (iii) and such other factors as we determine. You also agree that you will not offer for sale or sell at the Store any other products or services.

12.2 Pizza Ingredients, Supplies and Materials.

All pizza and other food ingredients, beverage products, cooking materials, containers, packaging materials, other paper and plastic products, utensils, uniforms, menus, forms, cleaning and sanitation materials and other supplies and materials used in the operation of the Store must conform to the specifications and quality standards established by us from time to time. You must use in the operation of the Store boxes, containers and other paper or plastic products imprinted with the Marks as prescribed from time to time by us. We may in our sole discretion require that ingredients, supplies and materials used in the storage, preparation, packaging, and delivery of pizza and other authorized food products be purchased exclusively from us, our affiliates or from approved suppliers or distributors. You agree to request delivery of food products to the Store in quantities and in a manner that is consistent with policies prescribed from time to time by us. Any

ingredient, supply or material not previously approved by us as conforming to our specifications and quality standards must be submitted for examination and/or testing prior to use. We reserve the right from time to time to examine the facilities of any approved supplier or distributor, including the commissary operated by you, if any, and to conduct reasonable testing and inspection of the ingredients, materials or supplies to determine whether they meet our standards and specifications. We also reserve the right to charge fees for testing and evaluating proposed suppliers or distributors and examining and inspecting commissary operations and to impose reasonable limitations on the number of approved suppliers or distributors of any product. Approval of a supplier or distributor may be conditioned on requirements relating to frequency of delivery and standards of service including prompt attention to complaints and the ability to service and supply Stores within areas designated by us.

13. ADVERTISING AND PROMOTION.

13.1 By DPF.

We or our designee will from time to time formulate, develop, produce and conduct advertising and promotional programs in the form and media as we or our designee determines to be most effective. You agree to participate in all national and local and regional advertising and promotions as we determine to be appropriate for the benefit of the Domino's System. We reserve the right, in our sole discretion, to determine the composition of all geographic territories and market areas for the development and implementation of advertising and promotion programs. All costs of the formulation, development and production of any such advertising and promotion (including without limitation the proportionate compensation of our employees who devote time and render services in the formulation, development and production of such advertising and promotion programs or the administration of the funds), will be paid from a separate fund administered by a separate not for profit entity (the "Advertising Fund"). You will be obligated to pay four percent (4%) of the weekly royalty sales of the Store to the Advertising Fund. Your contribution to the Advertising Fund must be paid by Thursday of each week on royalty sales for the week ending on the preceding Sunday. Payment must be made by electronic funds transfer as provided in Section 6.4 of this Agreement or as we may otherwise designate from time to time. All Domino's Pizza Stores owned by us or our affiliates will contribute to the cost of such advertising and promotion programs on at least the same basis as the majority of domestic franchisees in the Domino's System. We will submit to you upon request an annual statement of monies collected and costs incurred by the Advertising Fund. We reserve the right to engage the services of an advertising source or sources to formulate, develop, produce and conduct the advertising and promotion programs, the cost of such services to be payable from the Advertising Fund.

You acknowledge and understand that the Advertising Fund is intended to maximize general public recognition and patronage of the Marks in the manner determined to be most effective by us and our affiliates and that neither we nor our affiliates undertake any obligation in developing, implementing or administering these programs to ensure that expenditures which are proportionate or equivalent to your contributions are made for the market area of the Store or that any Domino's Pizza Store will benefit directly or pro rata from the placement of advertising or from other promotional programs.

From time-to-time we may, in our sole and absolute discretion, apply, collect or retain all or part of up to two percent (2%) of royalty sales that you are required to contribute or spend under Section 13.2 for expenditure by the Advertising Fund under this Section 13.1 (a "Roll-Up"). In the event of a Roll-Up, all contributions or payments made by you under Section 13.2 and allocated to the Advertising Fund ("Allocated Funds") shall be construed as if such Allocated Funds were made to the cooperative or for local advertising expenditures for purposes of determining your amount of contribution or payments to your cooperative or your required expenditures under Section 13.2.

In the event we commence a Roll-Up, we may continue such Roll-Up for a period of up to five (5) years commencing on the Roll-Up commencement date (the "Roll-Up Commencement Date") and ending on the day before the fifth (5th) anniversary of the Roll-Up Commencement Date, and, thereafter, we can continue such Roll-Up for additional periods of up to five (5) years each unless the cumulative domestic same-store sales percentage change reported by Domino's Pizza, Inc., measured from the Roll-Up Commencement Date until the last day of the fourth year of any such five year Roll-Up period (the "Same Store Sales Change"), shall be less than one-tenth of one percent (0.1%). If the Same Store Sales Change is less than one-tenth of one percent (0.1%), we can, nevertheless, continue the Roll-Up for additional periods of up to five (5) years unless (a) during the first (1st) quarter of the fifth (5th) year of such a Roll-Up, a vote is requested in writing by any franchisee in good standing (including, but not limited to, any franchisee not then in default) and operating under this provision, and (b) sixty-five percent (65%) of Domino's Pizza stores in good standing and operating under this provision vote to suspend such Roll-Up (a "Suspension Vote"). If there is a Suspension Vote, then such Roll-Up shall be suspended (the "Suspension") at the conclusion of the fifth (5th) year of such Roll-Up. Such Suspension shall remain in effect until sixty-five percent (65%) of Domino's Pizza Stores in good standing and operating under this provision vote to reinstate our ability to commence a Roll-Up (the "Reinstatement Vote") after which our ability to effectuate a Roll-Up will be as described above until such time that it is suspended pursuant to this Section 13.1. For purposes of the Suspension Vote and the Reinstatement Vote, all Domino's Pizza Stores in good standing and operating under this provision at the time of such vote and all corporate or affiliate owned Domino's Pizza Stores shall be entitled to vote on the basis of one vote per Store.

13.2 Local and Regional Advertising Cooperatives.

We reserve the right to require that you participate in local and regional advertising cooperatives administered by us or our affiliates or other franchisees of the Domino's System or, in the event no such cooperative has been established, to require you to conduct local advertising for your Store. In addition to the advertising contribution payable by you under Section 13.1, you agree to pay any contributions that we require you to make for expenditures by these local or regional cooperatives or that may be otherwise approved by these cooperatives or for local advertising if no cooperative exists. If there is no advertising cooperative or if the Domino's Pizza Stores participating in a cooperative have not agreed upon a percentage of royalty sales to be contributed to the cooperative, you must expend or contribute to the cooperative, respectively, an amount we specify up to and including two percent (2%) of royalty sales. If a cooperative exists and sixty-five percent (65%) or more of the Domino's Pizza Stores agree to contribute or are contractually obligated to contribute a specified percentage of royalty sales to the cooperative, then we can require you to make the same percentage contribution to the cooperative as the other Stores

in the cooperative. All Domino's Pizza Stores participating in a cooperative shall contribute no less than 2% of royalty sales. All Stores which are contractually obligated to contribute the specified percentage of royalty sales voted upon by the cooperative shall be counted as a favorable vote, whether or not they attend or vote at the meeting. We agree that the maximum aggregate amount we can obligate you to contribute for advertising and promotion under this Section 13.2 and Section 13.1 will be nine percent (9%) of the royalty sales of your Store. All contributions payable under this Section 13.2 must be paid by Thursday of each week on royalty sales for the week ending on the preceding Sunday. Payment must be made by electronic funds transfer as provided in Section 6.4 of this Agreement or as we may otherwise designate from time to time. Nothing contained in this Section 13.2 shall limit, affect or supersede any obligation on your part to contribute a greater percentage of the royalty sales of the Store pursuant to any separate agreement or understanding you may have with any such local or regional advertising or promotional cooperative. We reserve the right, on our behalf and on behalf of our affiliates, to engage the services of an advertising source or sources to formulate, develop, produce and conduct the advertising and promotion programs for the cooperatives or for local advertising if no cooperatives exists with the cost of these services payable from the cooperative advertising budget or contributions made by you in accordance with this provision.

13.3 By Franchisee.

All of your advertising, promotions and media relations, including, but not limited to, all public relations, social media, events and all advertising and promotions conducted by you or your employees whether through public appearances or in print, or on radio, television, the Internet, and other electronic media ("Your Advertising"), must be completely factual and shall conform to the highest standards of ethical advertising and be consistent with the then current image and policies relating to advertising and promotional programs of a Domino's Pizza Store. In the event Your Advertising, in our judgment, is deemed to be inappropriate in any way, you shall immediately terminate or remove Your Advertising upon receipt of notice from us. We do not assume any of your duties and responsibilities related to Your Advertising.

14. RECORDS AND REPORTS.

14.1 Bookkeeping and Recordkeeping.

You agree to establish and retain a bookkeeping, recordkeeping, computer and point of sale system (including a record of the names, addresses, telephone numbers and order history of the customers in your Store's delivery area all in form and format designated by us) conforming to the requirements prescribed by us, relating, without limitation, to the use and retention of daily sales information, counts of pizza types and other approved menu items sold, coupons, purchase orders, purchase invoices, payroll records, check stubs, bank statements, sales tax records and returns, cash receipts and disbursements, checks and credit card sales, journals and general ledgers, including any comparable electronically generated information or any supporting records or materials we may require or prescribe. You agree to retain all business records and reports (whether paper or electronically generated) relating to the Store in accordance with record retention policies and guidelines prescribed by us, from time to time, and for the time limits required by all applicable laws, ordinances and regulations. You also agree to maintain an emergency back-up order taking system and other back-up operational procedures identified by us

in accordance with policies and procedures we may prescribe from time to time. You agree that we shall have full access, either on-site or from a remote location, to all of your computer data, equipment and systems containing any and all of the information, records and reports required by this Section 14.1 or any other provision of this Agreement or any other agreement with our affiliates. In addition, you agree to provide us with access to all such data, equipment and systems to facilitate the exchange of information you are required to provide us under this Agreement. Any information provided by you shall be used by us in a lawful manner.

14.2 Sales Reports and Financial Statements.

You agree to submit to us, in accordance with requirements prescribed by us from time to time and in a format which we may designate from time to time:

- (a) with the royalty fee due, a weekly report of the sales of the Store and all other information and supporting records as we may require;
- (b) within sixty (60) days of the end of each fiscal year of the Store;
 - (i) a statement of cash flow and cash on hand, an unaudited balance sheet as of the end of the year and an unaudited annual statement of profit and loss and financial condition of the Store prepared on an accrual basis;
 - (ii) if you are a corporation, partnership or other approved entity, a statement of cash flow and cash on hand, an unaudited balance sheet as of the end of the year and an unaudited statement of profit and loss of the corporation, partnership or approved entity prepared on an accrual basis; and
 - (iii) if you have additional Domino's Pizza Stores, a consolidated statement of profit and loss for all of your operations, including any additional Domino's Pizza Stores which you own and all administrative and commissary operations. The statements must be prepared in accordance with generally accepted accounting principles by an accountant in the manner prescribed by us;
- (c) promptly upon our request and within twenty (20) days of the end of the month or period, in the manner as we may prescribe, and continuing for such period of time as we may from time to time designate:
 - (i) a statement of cash flow and cash on hand, an unaudited balance sheet as of the end of the month or period and an unaudited statement of profit and loss of the Store prepared on an accrual basis for each month or period;
 - (ii) if you are a corporation, partnership or other approved entity, a statement of cash flow and cash on hand, an unaudited balance sheet as of the end of the month or period and an unaudited statement of profit and loss of the corporation, partnership or approved entity prepared on an accrual basis for each month or period; and

(iii) a consolidated statement of profit and loss for all of your Domino's Pizza Stores for each month or period;

(d) if you are in default under any of the terms or conditions of this Agreement, statements submitted on a quarterly basis affirming that all federal, state and local taxes have been paid;

(e) upon our written request, exact copies of your and your owners federal, state and local business income tax returns and state sales tax or equivalent tax returns for any period; and

(f) such other information as we may reasonably require to determine you and your owners' compliance with this Agreement or to assist you in the operation of the Store or to otherwise evaluate the performance of the Store, including information about the sales and receipts of the Store.

14.3 Right to Require Audit.

We reserve the right to audit the sales reports, financial statements, tax returns, information from the Store's computer system, and any other records you are required to retain or submit to us. In the event any audit discloses an understatement of the royalty sales of the Store for any period or periods (regardless of whether the understatement is intentional or not), we shall have the right to require that you pay on the amount of such understatement the royalty fee of five and one-half percent (5-1/2%), all advertising contributions due under this Agreement and the amount, if any, required to be paid to your local or regional cooperative as provided in this Agreement, plus interest due. Further, in the event such understatement for any period or periods shall be two percent (2%) or more of the royalty sales of the Store or such inspection or audit is made necessary by your intentional or negligent underreporting (including, without limitation, underreporting that arises out of your insufficient supervision of your employees) or your failure to furnish reports, supporting records, financial statements or other information required by this Agreement or to furnish these reports, records, information or financial statements on a timely basis, you will be obligated to reimburse us for the cost of the audit, including the charges of any independent certified public accountant used and the travel expenses, room and board and compensation of our employees or anyone we engage to conduct the audit. In the event you dispute the results of any audit conducted by us or our representatives, you will have the right, upon written notice to us within ten (10) days of your receipt of the results of our audit, to have the results verified by an independent certified public accounting firm selected by our outside accounting firm. The expense of this audit shall be borne by you unless this further audit discloses that no deficiency is due in which case we will be obligated to pay for the audit. We will notify you within ten (10) days of our receipt of your notice when the independent audit will commence. You agree to cooperate with all personnel conducting the audit. The results of the independent audit shall be binding upon the parties. You agree to pay any deficiencies within ten (10) days after receipt of our audit or, if applicable, the independent audit requested by you. You acknowledge and agree that conducting an audit as authorized by this section is one but not the only way we may determine or establish that you have underreported the royalty sales

of the Store for any period or periods. You and your owners agree to fully comply and cooperate with any and all audits, including, but not limited to, you, your owners and your employees treating our personnel in a professional manner.

15. OPERATING REQUIREMENTS.

15.1 Operating Procedures.

You agree to fully comply with all specifications, standards and operating procedures and rules from time to time prescribed for the operation of a Domino's Pizza Store, including, but not limited to, specifications, standards and operating procedures and rules relating to:

(a) the safety, maintenance, cleanliness, sanitation, function and appearance of the Store premises and its equipment, (including computer hardware, software, peripheral devices, high speed broadband connectivity, high speed broadband monitoring, and methods and means of encryption and access to our network resources), image, fixtures, furniture, decor and signs;

(b) qualifications, dress, grooming, general appearance and demeanor of you and your employees, including, but not limited to, engaging in any conduct which, in our judgment, adversely affects the reputation of the Store or the Domino's System or the goodwill associated with the Marks or involves dishonesty, fraud, deceit, illegal conduct, misrepresentation or moral turpitude;

(c) quality, taste, portion control and uniformity, and manner of storage, preparation and sale, of all pizza and other authorized food and beverage products sold by the Store and of all ingredients, supplies and materials used in the storage, preparation, packaging and sale of these items;

(d) methods and procedures relating to receiving, preparing, delivering and storing customer orders, including without limitation, online ordering;

(e) the hours during which the Store will be open for business;

(f) use and illumination of exterior and interior signs, posters, displays, menu boards and similar items;

(g) the handling of customer complaints;

(h) advertising on the Internet or other electronic media, including websites, home pages and the use of domain names;

(i) e-mail capabilities of the Store and other electronic communication methods (including high speed broadband connectivity, high speed broadband monitoring, and methods and means of encryption and access to our network resources) and devices to facilitate communication with us or our offices, including the exchange of information between the Store and us; and,

- (j) the method and manner of payment which will be accepted from customers.

By entering into this Agreement, you agree to abide by these specifications, standards, operating procedures and rules and to fully adopt and implement them.

15.2 Compliance with Laws and Other Business Practices.

You agree to secure and maintain in force all required licenses, permits and certificates and operate the Store in full compliance with all applicable laws, ordinances and regulations. You also agree to pay when due all amounts payable pursuant to any provision of this Agreement or any other agreement with us or our affiliates or subsidiaries or pursuant to any agreement with any other creditor or supplier of the Store. You shall file all tax returns and pay all taxes before they become delinquent. You agree not to permit any levy or warrant to be issued by any taxing authority or other creditor, (excluding mechanics liens and other immaterial liens), against any of your assets, nor allow any of your assets to be seized or frozen by any taxing authority or other creditor. Furthermore, if you are subject to any withholding taxes on royalty fees or other payments due, you shall provide us with quarterly evidence that such tax has been remitted to the appropriate governmental agency on a quarterly basis.

You agree to abide by the Payment Card Industry Data Security Standards enacted by the applicable Card Associations, applicable to your business. If you know or suspect a security breach, you shall immediately notify us. You shall promptly identify and remediate the source of the compromise. You assume all responsibility for providing all notices of breach or compromise and all duties to monitor credit histories and transactions concerning your customers. Without limiting the generality of other provisions of this Agreement, you agree to defend, indemnify and hold us and our affiliates harmless from and against any and all claims, demands, duties, obligations, damages, fines and/or penalties imposed upon you as a result of non-compliance with the Payment Card Industry requirements.

You and your owners acknowledge that Executive Order 13224 (the "Executive Order") prohibits transactions with terrorists and terrorist organizations and that the government of the United States has adopted and may in the future adopt other anti-terrorism measures (the "Anti-Terrorism Measures"). You certify that neither you or your owners nor any of your employees, affiliates or any other person or entity associated with the Store is: (1) a person or entity listed in the Annex to the Executive Order; (2) a person or entity otherwise determined pursuant to the Executive Order to have committed acts of terrorism or to pose a significant risk of committing acts of terrorism (such a person or entity and those persons and entities listed in the Annex to the Executive Order are referred to herein as "Terrorists"); (3) a person or entity who assists, sponsors or who supports Terrorists or acts of Terrorism ("Sponsors of Terrorism"); or (4) owned or controlled by Terrorists or Sponsors of Terrorism. Furthermore, you covenant that neither you or your owners, nor any of your employees, affiliates or any other person or entity associated with the Store shall, during the term of this Agreement, become a person or entity described in clause (1), (2) or (3) above, or shall otherwise become a target of any Anti-Terrorism Measures. Should you or any of your owners, employees, affiliates, or any person or entity associated with the Store, violate the provisions of this paragraph, we will have the right to immediately terminate this Agreement.

15.3 Pricing.

We reserve the right, to the fullest extent allowed by applicable law, to establish maximum, minimum, or other pricing requirements with respect to the prices you may charge for products and services, including pricing we prescribe from time to time for any national, regional or local advertising or promotion.

15.4 Operating Manual.

We will loan to you during the term of the franchise one or more copies of an operating manual or operational bulletins or similar materials containing mandatory and suggested specifications, standards and operating procedures and rules prescribed from time to time by us and information relative to your other obligations under this Agreement and the operation of the Store (the "Operating Manual"). We will provide you with a manual or electronic copy of the Operating Manual. The entire contents of the Operating Manual will remain confidential and are proprietary to us and our affiliates. We will have the right to add to and otherwise modify the Operating Manual from time to time, if deemed necessary to improve the standards of service or product quality or the efficient operation of the Store, to protect or maintain the goodwill associated with the Marks, to take advantage of advancements in technology, or to meet competition. No such addition or modification, however, shall alter your fundamental status and rights under this Agreement. The provisions of the Operating Manual as modified from time to time, including the mandatory specifications, standards and operating procedures and rules prescribed from time to time by us and communicated to you in writing, will constitute provisions of this Agreement as if contained in this Agreement.

15.5 New Concepts.

If you develop any new concept, process or improvement or any slogan in the operation or promotion of the Store, or technology used in connection with the operation of the Store, you agree to promptly notify us and provide us with all necessary information without compensation. You acknowledge that any such concept, process, improvement or slogan shall become our property and that we may utilize or disclose this information to our affiliates and other franchisees.

15.6 Franchisee Must Directly Supervise Store.

The Store shall at all times be under the direct, on-premises supervision of you (or the Controlling Person if you are an Approved Entity). You (or the Controlling Person if you are an Approved Entity) must devote full time and efforts (excluding reasonable vacation periods) as manager of the Store or to the management of other Domino's Pizza Stores (or other related activities approved by us in accordance with Section 7.1 of this Agreement). You shall be solely responsible for recruiting, hiring, training, scheduling for work, supervising and paying the persons who work in the Store and those persons shall be your employees, and not our agents or employees. Further, neither you nor any of your owners may, during the term of this Agreement, without our prior written consent, which may be withheld in our sole judgment, (i) engage, or own any interest, in any other business activity, (ii) be employed by any other business, (iii) engage in any activity which may impair your ability to fulfill your obligations under this Agreement, or (iv) engage in any conduct which, in our judgment, adversely affects the reputation of the Store or the Domino's

System or the goodwill associated with the Marks or involves dishonesty, fraud, deceit, illegal conduct, misrepresentation or moral turpitude.

If you own more than one (1) Store, each Store must also be under the direct, on-premises supervision of a manager, whose conduct (including, without limitation, acts or failure to act) you will be responsible for, and:

(a) who has been properly trained by you on all specifications, standards, operating procedures and rules from time to time prescribed for the operation of a Domino's Pizza Store including, without limitation, proper reporting of royalty sales;

(b) whose identity has been disclosed to us; and

(c) who shall have executed, upon our request, an agreement in the form provided by us agreeing not to divulge any trade secret or confidential or proprietary information, including the contents of the Operating Manual, or to engage in or have any interest in any other carry-out or delivery pizza store business.

15.7 Insurance.

You shall at all times during the term of the franchise maintain in force at your sole expense:

(a) property insurance on a replacement cost basis at a minimum limit based on the total value of your assets (including, but not limited to, fire, extended coverage, vandalism and malicious mischief),

(b) general liability insurance with a minimum limit of \$1,500,000.00 per occurrence (including, but not limited to, coverage for personal injury, products and contractual liability),

(c) automobile liability insurance with a minimum limit of \$1,500,000.00 per occurrence (including, but not limited to, owned automobiles titled or leased in the name of you or your owners and used at any time, whether principally or occasionally in your business, hired and non-owned coverage). If you or your owners do not use a vehicle owned or leased in the name of you or any of your owners in your business, you must provide written evidence of that fact, satisfactory to us, and

(d) workers' compensation insurance (in your name) as required by applicable law. If no such law exists, then you must participate in such other comparable insurance or benefit programs for your employees as required by us. If your state recognizes and permits self insurer programs, your participation in such a program will satisfy our requirements under this subsection (d). If deductible plans are approved and used in your state, coverage may be purchased on this basis subject to the requirements of your insurance carrier.

All liability insurance policies must name us, and any subsidiaries and affiliates which we designate, as additional insureds entitled to the coverage afforded to all named insureds, without

regard to any other insurance or self-insured program which we or our affiliates or subsidiaries may have in effect, and also provide that we receive thirty (30) days prior written notice of termination, expiration, cancellation, modification or reduction in coverage or limits of any such policy. The terms and conditions of all such policies, including the amount of any deductibles, shall be consistent with the requirements prescribed from time to time by us. You agree to promptly pay when requested by the insurer the amount of the deductible applicable to, and in the event of, any covered loss.

All insurance policies (excluding workers' compensation policies) must be issued by an insurance carrier rated B+ or better by Alfred M. Best & Company, Inc. or meeting such other rating or criteria we may establish from time to time. We may also reasonably increase the minimum liability "limit" protection requirement annually and require different or additional kinds of insurance to reflect inflation, changes in standards of liability, higher damage awards in public, product or motor vehicle litigation or other relevant changes in circumstances. You must submit to us annually a copy of the certificate of insurance or evidence of the renewal or extension of each such insurance policy or any modifications to any such insurance policies, which must describe the applicable deductibles for each such policy. If at any time you fail or refuse to maintain in effect any insurance coverage required by us, or to furnish satisfactory evidence of such insurance, we may, at our option and in addition to other rights and remedies we may have, obtain insurance coverage, on your behalf, and you agree to promptly execute any applications or other forms or instruments required to obtain any such insurance and pay to us on demand any costs and premiums incurred by us. Your obligation to obtain and maintain the insurance described in this Agreement shall not be limited in any way by reason of any insurance maintained by us.

15.8 Identification as Franchisee.

You agree to exhibit (a) on the Store premises and (b) on all delivery vehicles (or on car top signs on all delivery vehicles) signs of sufficient prominence and wording as we may prescribe from time to time so as to advise the public that the Store is owned, operated and maintained by you and that each such delivery vehicle is owned, operated and maintained by you or the driver of the vehicle, as the case may be. All business cards, letterheads and other business materials shall clearly identify that you are the owner of the Store in accordance with the rules or policies we may establish from time to time in the Operating Manual or otherwise in writing. In addition, subject to rules and policies that may be established from time to time, all local advertising, including yellow page listings and advertisements that are placed by you or on your behalf, and which do not contain phone numbers or addresses that are associated with stores that we own or operate, shall either indicate that you are the owner of the store or stores in the print material, or that the store or stores are locally owned and operated.

15.9 Computer Hardware and Software and Other Technology.

15.9.1 Brand Technology.

You agree to use in the development and operation of the Store the management system and computer hardware and software and related technology designated by us, including without limitation, features such as high speed broadband connectivity, high speed broadband monitoring, online ordering, methods and means of encryption and access to our network resources, and other

brand technology and peripheral devices that we specify from time to time (the "Brand Technology"). You acknowledge that we may modify all aspects and the components of the Brand Technology from time to time. As part of the Brand Technology, we may require you to obtain computer hardware and/or software we specify from a single vendor designated by us and we or our affiliates may be the sole supplier of all or any part of the Brand Technology. You agree to use only such items and services as we specify in connection with the Brand Technology. We may require that you enter into a license exclusively with us or our affiliates to use proprietary software developed by or for us. You may also be required to enter into agreements with others for use of third party software incorporated or used in connection with the Brand Technology. Our modification of such specifications or components for the Brand Technology may require you to incur costs to purchase, lease and/or license new or modified computer hardware and/or software and to obtain service and support for the Brand Technology during the term of this Agreement. You acknowledge that the cost to you of obtaining the Brand Technology (including software licenses) (or additions, substitutions, replacements or modifications thereto) may not be fully amortizable over the remaining term of this Agreement. Nonetheless, subject to the provisions of Section 15.9.2 below, you agree to incur such costs in connection with obtaining the computer hardware and software comprising the Brand Technology (or additions, substitutions, replacements or modifications thereto). You further acknowledge and agree that we have the right to charge reasonable fees for software or systems modifications and enhancements specifically made for us that are licensed to you and other maintenance and support services that we or our affiliates furnish to you related to the Brand Technology. You may also incur charges from third parties who render services or provide products that we require you to purchase or use. We shall have independent access through monitoring programs or otherwise to data on your Brand Technology, including sales figures. There are no contractual limitations on our right or timing to access this information and data.

Without limiting the generality of the foregoing, we reserve the right to require you to acquire, install and continuously use the Domino's PULSE store computer system and to obtain a license to use the software from us or our affiliate by signing our standard license agreement and to acquire hardware approved by us from a vendor or vendors which we designate. We also reserve the right to require you to participate in online ordering by entering into an agreement with an approved online ordering service company that we designate. You will be responsible for the fees and charges associated with your use of online ordering and the requisite internet usage and connections, including the fees charged by the service provider. We may also require that you continuously maintain high speed broadband connectivity, where available and to charge you a reasonable fee if you do not maintain high speed broadband connectivity, which you agree to pay on demand. You acknowledge and agree that changes to technology are dynamic and not predictable within the term of this Agreement. In order to provide for inevitable but unpredictable changes to technological needs and opportunities, you agree that we shall have the right to establish, in writing, reasonable new standards for the implementation of technology in the Domino's System; and you agree to abide by and fully adopt and implement those reasonable new standards established by us as if this Section 15.9.1 were periodically revised by it for that purpose.

15.9.2 Aggregate Expenditures for Brand Technology.

You will not be required to make aggregate expenditures for any additions, substitutions, replacements or modifications to the Brand Technology in excess of one and one half percent (1

½ %) of the royalty sales of the Store from the date of its opening to the date we require you to make any additions, substitutions, replacements or modifications to the Brand Technology not to exceed the ten (10) year period prior to the date we require you to make any additions, substitutions, replacements or modifications to the Brand Technology or, except in connection with a renewal of the franchise to make any additions, substitutions, replacements or modifications to the Brand Technology during the last twelve (12) months of the initial term of the franchise. This limitation shall not apply to our right to require that you acquire and install the Domino's PULSE store computer system or other components of the Brand Technology upon execution of this Agreement nor shall the provisions of any prior franchise agreement governing the operation of the Store restrict our right to require that you acquire and install the Domino's PULSE store computer system or other components of the Brand Technology under the terms of this Agreement.

15.9.3 Domino's PULSE and Other Computer and Technology Training.

If you (or the Controlling Person if you are an Approved Entity) have not installed and used Domino's PULSE, or any other computer system or technology that we require, in a Domino's Pizza store, you (or the Controlling Person) must enroll in and complete all training programs and classes which we require for the operation of Domino's PULSE, or any other computer system or technology. These training programs and classes will be furnished at such times and places as designated by us or the entity or entities that we approve to provide the training. We may furnish training. The entity furnishing the training (including us) has the right to charge a reasonable training fee for these training programs or classes, which you agree to pay. All training programs and classes must be completed to our satisfaction. You will be responsible for the travel, living expenses and any other costs incurred during these training programs and classes.

15.9.4 Additional Order Processing Systems.

We reserve the right to develop or contract with third parties to develop centralized or technology based methods of taking, processing, routing, and delivering orders in addition to the methods and technology we currently use or authorize (collectively "Additional Order Systems"). These may become mandatory at any time during the term of this Agreement and may require you to spend money to add or replace equipment, wiring, hardware and software; to pay licensing fees, support and maintenance fees, fees paid to third parties; to incur other costs, and to sign agreements with third parties. To the extent these products and services are owned by us or provided to you by us, we may charge up front and/or ongoing fees. However, to the extent all the direct and indirect costs to develop, test and implement an Additional Ordering System are paid from other sources, then such up-front and ongoing fees charged by us would be intended only to cover our ongoing expenses, including direct costs and reasonable allocations. Regardless of the sources of funds to develop any Additional Ordering System we shall be the sole owner of all direct and related rights and assets, including software and hardware, intellectual property and all data generated by the Additional Ordering Systems, but excluding hardware or equipment you purchase directly for the purpose of gaining access to the Additional Ordering System.

16. MARKS.

16.1 Usage.

You acknowledge that we have the right to sublicense the Marks and that any goodwill relating to your use of the Marks will inure to our benefit and the benefit of our affiliates. You shall use the Marks in full compliance with rules prescribed from time to time by us. You agree not to engage in any conduct which, in our sole judgment, could disparage or impair the reputation of the Store or the Domino's System or the goodwill associated with the Marks. You understand and acknowledge that our right to regulate the use of the Marks, includes, without limitation, any use of the Marks in any form of electronic media such as web sites or web pages or as a domain name or electronic media identifier. Any unauthorized use of the Marks will constitute a breach of this Agreement and an infringement of our rights in and to the Marks. You will not use any Mark as part of any corporate name or with any prefix, suffix or other modifying words, terms, designs or symbols or in conjunction or association with any name or symbol used by you in connection with the operation of the Store, nor may you use any Mark in connection with the sale of any unauthorized product or service or in any other manner not explicitly authorized in writing by us. All provisions of this Agreement applicable to the Marks will apply to any additional proprietary trademarks and commercial symbols we hereafter authorize you to use.

16.2 Infringements.

You agree to immediately notify us of any infringement of or challenge to your or our use of any Mark or claim by any person of any rights in any Mark. You agree that you will not communicate with any person other than us and our counsel in connection with any such infringement, challenge or claim. We will have sole discretion to take such action as we deem appropriate and the right to exclusively control any litigation or Patent and Trademark Office or other proceeding arising out of any infringement, challenge or claim or otherwise relating to any Mark. You agree to execute any and all instruments and documents, render such assistance and do such acts and things as may, in the opinion of our counsel, be necessary or advisable to protect and maintain our interests in any such litigation or Patent and Trademark Office or other proceeding or to otherwise protect and maintain our interest in the Marks.

16.3 Indemnification.

We will indemnify you against and reimburse you for all damages for which you are held liable in any proceeding arising out of the use of any Mark in compliance with this Agreement. If it becomes advisable at any time in our sole discretion for you to modify or discontinue use of any Mark and/or use one or more additional or substitute Marks, you agree to do so and our sole obligation will be to reimburse you for your tangible costs of complying with this obligation.

17. INSPECTIONS.

We or our designee will have the right at any time during business hours and without prior notice to conduct reasonable inspections of the Store, its operations and its business records, including, but not limited to, information from the Store's computers, and records and documents relating to the ownership and control of the Approved Entity and any other entity that has an interest in the operation of the Store, wherever located and to take a physical inventory of the assets

of the Store. You agree that we may conduct all or part of an inspection, either on-site or from a remote location. Inspections of the Store will be made at our expense, unless we are required to make any additional inspections in connection with your failure to comply with this Agreement. In such event, we will have the right to charge you for the costs of making all additional inspections in connection with your failure to comply, including without limitation the travel expenses, room and board and compensation of our or our designee's employees. You and your owners agree to fully comply and cooperate with any and all inspections, including, but not limited to, you, your owners and your employees treating our personnel in a professional manner.

18. TERMINATION AND EXPIRATION.

18.1 Termination By Franchisee.

If you are in compliance with this Agreement and we breach this Agreement and fail to cure any breach within thirty (30) days after written notice is delivered to us, you may terminate this Agreement and the franchise effective ten (10) days after delivery of notice to us. A termination of this Agreement and the franchise by you without complying with these requirements or for any reason other than our breach of this Agreement and our failure to cure the breach within thirty (30) days after receipt of written notice from you shall be deemed a termination by you without cause and not in accordance with the provisions of this Agreement.

18.2.1 Immediate Termination By DPF - Upon Written Notice.

We shall have the right to terminate this Agreement effective upon delivery of notice of termination to you, if:

- (a) you or any of your owners have made any material misrepresentation on any record or report required by us under this Agreement or on your application for the franchise, or in any other application submitted to us;
- (b) you do not open the Store within six (6) months from the date of this Agreement;
- (c) you or any of your owners is judged a bankrupt, becomes insolvent, makes an assignment for the benefit of creditors, is unable to pay his or her debts as they become due, or a petition under any bankruptcy law is filed against you or any of your owners or a receiver or other custodian is appointed for a substantial part of the assets of the Store;
- (d) you abandon or fail to continuously and actively operate the Store, or, without our prior written consent, permit any person other than a qualified employee designated by you, whose identity has been disclosed to us, to operate the Store in your absence;
- (e) the lease or sublease for the Store is terminated or cancelled or you are unable to renew or extend the lease or sublease or you fail to maintain possession of the Store premises unless you are permitted to relocate the Store under Section 7.2 of this Agreement;

(f) you or any of your owners is convicted of a felony, or a crime which substantially impairs the goodwill associated with the Marks or you or any of your owners engages in any conduct which, in our judgment, adversely affects the reputation of the Store or the Domino's System or the goodwill associated with the Marks or involves dishonesty, fraud, deceit, illegal conduct misrepresentation or moral turpitude;

(g) you intentionally or negligently under-report the royalty sales of the Store for any period or periods;

(h) you or any of your owners violates any of the restrictions contained in Section 20 or 21 of this Agreement;

(i) you intentionally or on more than one occasion during the term of this Agreement, violate any Child Labor Laws in connection with your operation of the Store;

(j) an audit by us discloses an understatement of royalty sales and you fail to pay to us the applicable royalty fee and advertising contribution and interest due within ten (10) days after receipt of the final audit report;

(k) the interest of a deceased or permanently disabled person is not disposed of in accordance with the terms of this Agreement;

(l) you or any of your owners fail on three (3) or more occasions during any twelve (12) month period to comply with any one or more provisions of any franchise agreement for the Store (which includes not only this Agreement but also the franchise agreement in force immediately prior to this Agreement if this Agreement has been in effect for less than twelve (12) months) including without limitation, your obligation to submit when due, sales reports or financial statements, to pay when due the royalty fees, advertising contributions or other payments to us or our affiliates or subsidiaries or any other creditors or suppliers of the Store, whether or not such failure to comply is corrected after notice is delivered to you; or

(m) any of your assets or items used in the operation of the Store are seized or you are otherwise denied the use of the property or access to the Store because of your failure to pay any taxing authority or any amount due a creditor of the Store, or because of any other act or omission of you or any of your owners; or, you fail to notify us of a tax levy or delinquency.

(n) you fail to cease operating the Store, or fail to correct the conditions in the Store causing a present threat of imminent danger to public health or safety, after notice to you as provided in Section 18.2.3 of this Agreement;

(o) we have granted you permission to either repair, restore, reconstruct or relocate the Store, as provided in Section 7.2 of this Agreement, and you fail to complete the action we have permitted, within six (6) months after its closure; or

(p) you or your owners violates any of the anti-terrorism provisions contained in Section 15.2 of this Agreement.

18.2.2 Termination By DPF - After Opportunity to Cure.

We shall have the further right to terminate this Agreement effective upon delivery of notice to you, if:

(a) you fail to obtain or maintain insurance required by us and you do not correct this failure within forty-eight (48) hours after written notice is delivered to you; provided, however, that we shall not exercise our right to terminate this Agreement if you immediately cease operating the Store and obtain all such insurance within ten (10) days after written notice is delivered to you;

(b) you fail to comply with any provision of this Agreement or any specification, standard or operating procedure or rule prescribed by us which relates to the use of any Mark, safety and security, or the quality of pizza or other authorized food products or any beverage sold by you or the cleanliness and sanitation of the Store and you do not correct this failure within seven (7) calendar days after written notice is delivered to you;

(c) you or your affiliates fail to pay when due any amount owed to us, our affiliates or subsidiaries, or any creditor or supplier or any taxing authority for federal, state or local taxes (other than amounts being bona fide disputed through formal proceedings) and you or your affiliates do not correct such failure within ten (10) calendar days after written notice is delivered to you; or

(d) you or any of your owners fails to comply with any other provision of this Agreement or any specification, standard or operating procedure and fail to correct this failure within thirty (30) calendar days after written notice is delivered to you.

18.2.3 Immediate Cessation of Operations .

In the event that the conditions of the Store or operations at the Store, in our judgment, present a threat of imminent danger to public health or safety, we may require the immediate cessation of operations at the Store upon delivery of a notice to you or the Store. The notice shall contain the reason we believe immediate cessation of operations is required. The parties shall address the conditions and develop a plan to correct all deficiencies within seven (7) days of the delivery of the notice.

18.3 Obligations Upon Termination or Expiration.

Upon termination or expiration of this Agreement, you agree to:

(a) immediately return to us all copies of the Operating Manual and cease use of and deliver to us all Customer Lists (as hereinafter defined in Section 20.5);

(b) take such action as may be required to cancel all assumed name or equivalent registrations relating to the use of any Mark;

(c) notify the telephone company, postal service, and all listing agencies in writing of the termination or expiration of your right to use all telephone numbers, post office boxes, and all classified and other directory listings relating to the Store and to authorize in writing the transfer of these to us or our franchisee or designee. You acknowledge that we have the sole rights to and interest in all telephone numbers, post office boxes, and directory listings relating to any Mark, and you authorize us to direct the telephone company, the postal service, and all listing agencies to transfer all telephone numbers, post office boxes, and directory listings to us, our franchisee or designee and if you fail or refuse to do so, the telephone company, postal service, and all listing agencies may accept our direction as evidence of our exclusive rights in the telephone numbers, post office boxes, and directory listings and our authority to direct the transfer. Upon execution of this Agreement or at any time thereafter, you agree to execute any written authorizations or pre-approved authorizations in the form prescribed by us directing the telephone company, postal service, and any listing agencies to transfer all telephone numbers, post office boxes, and directory listing to us, our franchisee or designee upon the occurrence of any such termination or expiration;

(d) immediately pay all royalty fees, advertising contributions and other charges which are due and owing under this Agreement;

(e) immediately cease using the Marks and identifying yourself as a Domino's Pizza Store or as being associated with the Domino's System, including, without limitation, disabling and ceasing to permit the continued operation of any website relating to the Store or the Domino's System or which utilizes the Marks;

(f) if you retain possession of the Store premises, at your expense, make such reasonable modifications to the exterior and interior of the Store (including signage, menu boards, job aids, product photos and the like) as we require to fully eliminate its identification and appearance as a Domino's Pizza Store. If you fail or refuse to fully de-identify the Store to the extent and in the manner required by this Agreement, we may, at our option and in addition to other rights and remedies we may have, make the modifications that are contemplated by this Agreement on your behalf and you agree to promptly pay and reimburse us on demand for any costs incurred by us or our designee including, without limitation, the proportionate compensation of our or our designee's employees who devote time and render services in the de-identification of the Store; and

(g) make the Store accessible and available for us to operate pursuant to Section 19.8 of this Agreement if we elect to do so.

19. OPTION TO PURCHASE STORE.

19.1 Option.

Upon the termination or expiration of this Agreement, except termination by you for cause, we shall have the exclusive option, but not the obligation, to purchase the assets of the Store. For

purposes of this section, the term "assets" shall mean the equipment, inventory, leasehold interests and improvements and favorable rights and covenants of the Store, but exclusive of delivery vehicles. Our option shall commence upon expiration of this Agreement or on the date of termination as applicable, and shall continue for thirty (30) days thereafter, subject to extension as provided in this Section. You agree that if the termination is stayed, either by us or by judicial proceedings, or if we are not permitted to manage the Store pursuant to section 19.8, we will not be able to exercise our option within the 30 day period and you also agree that under those circumstances our option to purchase shall be extended, without further notice to you, for an additional time which shall include the entire time we are unable to exercise our option.

19.2 Formula Price.

The purchase price for these assets shall be equal to fifteen percent (15%) of the first Three Hundred Thousand Dollars (\$300,000.00) of royalty sales ("Base Amount") of the Store during the fifty two (52) full weeks immediately preceding the date of termination or expiration plus twenty-five (25%) of royalty sales in excess of the Base Amount up to Five Hundred Thousand Dollars (\$500,000.00) ("Second Level Base Amount") during this period plus fifty percent (50%) of royalty sales in excess of the Second Level Base Amount during this period. The purchase price shall be allocated among the assets and covenants in the manner prescribed by us.

If the Store has been in operation less than fifty two (52) full weeks, the option price shall be the documented cost of the Store. The term "cost" shall be defined as your documented expenditures for the equipment, inventory and leasehold improvements of the Store, but shall not include any charges for labor performed by you or your family members in connection with the development of the Store or any undocumented costs.

19.3 Purchase of Commissary.

In the event you operate a commissary in connection with the Store, we shall also have the option to purchase the assets of the commissary. The purchase price for the assets of the commissary will be the net book value (based upon a seven year depreciation schedule).

19.4 Deductions From Purchase Price.

In the event we elect to purchase the assets of the Store, the purchase price will be reduced by:

- (a) the total current and long term liabilities of the Store assumed by us as described below; and,
- (b) the amount necessary to upgrade and renovate the Store to meet our then current standards for a Domino's Pizza Store; and,
- (c) our reasonable attorney's fees incurred in connection with enforcing this Agreement or in securing possession of the Store.

We will assume all current and long term liabilities, whether or not included on your financial statements up to the amount of the purchase price subject, however, to all defenses

available to you. Further, the amount we charge for upgrading and renovating the Store will not exceed one and one-half percent (1-1/2%) of the royalty sales of the Store from the date of opening to the date of termination or expiration reduced by an amount equal to the total expenditures made by you for renovation and upgrading of the Store at our request up to the date of termination or expiration.

19.5 Payment of Purchase Price.

The balance of the purchase price, after deductions described above will be payable as follows: ten percent (10%) of the balance at the time of closing and the remainder in sixty (60) equal monthly installments of principal plus interest at a rate of interest per annum equal to the prime lending rate charged by Morgan Guaranty Trust Company of New York (or other bank or financial institution we may designate) determined as of the closing date with annual adjustments based on the prime rate charged on each anniversary date. The first payment will be due on the first day of the second succeeding calendar month following closing and the remaining payments on the first day of each month thereafter. On the first payment date, interest from the date of closing shall also be paid. If we elect to pay the entire purchase price at closing, we shall have the right to escrow such portion of the purchase price as we deem appropriate for a period of six (6) months to cover liabilities of the Store. We shall notify you of claims asserted by creditors of the Store against the escrow monies. You shall have forty-eight (48) hours to settle any claim with such creditor prior to disbursement of funds from the escrow. If there is a good faith dispute between you and a creditor of the Store, you shall have thirty (30) days to reach a settlement with any such creditor as to the amount owed before we will disburse any escrow monies to such creditor. If you are unable to resolve the discrepancy with the creditor within the thirty (30) day period, we shall have the right to use the escrow monies to satisfy the claim of any such creditor. At the end of such six (6) month period, any remaining purchase price shall be remitted to you along with a statement prepared by us indicating the manner in which these funds were expended.

19.6 Real Property.

(a) In the event you or your owners own the real property on which the Store or commissary is located, and such property is not a multi-tenant unit, we will also have the exclusive option to purchase this property. We shall exercise this option within the same period of time as provided in section 19.1, as that time may be extended. The purchase price will be the fair market value as determined by an independent appraiser selected by both of us. If we cannot agree on an independent appraiser, we each shall select an independent appraiser who shall select a third independent appraiser. The independent appraiser selected by our appraisers shall determine the fair market value of the real property and his determination shall be final and binding on the parties, provided, in the event the independent appraiser does not render its appraisal within ninety (90) days of selection, the appraisal shall be made by the appraiser we have selected. The purchase price will be payable in full at the closing minus customary prorations including the pay-off of existing mortgage liens.

(b) If we do not elect to purchase the real property, or if the property is in a multi-tenant unit, we or our designee will have the option to enter into a lease for a term of not less than five (5) years with an option by the lessee to extend the term of the lease for an additional term of five (5) years. The lease shall contain the terms and conditions contained in the form of lease then used

by us or our affiliates in connection with Domino's Pizza Stores owned and operated by us or our affiliates. The rental under the lease for the initial five (5) year term shall be the fair rental value of the property as determined by an independent appraiser selected in the manner described above. The rental shall be modified during the second five (5) year option term by the percentage that the National Consumer Price Index for Urban Wage Earnings and Clerical Workers as determined by the United States Department of Labor for the region in which the Store is located (or a comparable index if such Index is not then being issued) has increased or decreased from the commencement date of the initial term until the last day of the initial term of the lease.

19.7 Closing.

The closing shall occur within thirty (30) days after we exercise our option to purchase the assets and/or real property or such later date as may be necessary to comply with applicable bulk sales or similar laws. At the closing, we both agree to execute and deliver all documents necessary to vest title in the purchased assets and/or real property in us free and clear of all liens and encumbrances, except those assumed by us and/or to effectuate the lease of the Store premises. You also agree to provide us with all information necessary to close the transaction. We reserve the right to assign our option to purchase the Store or commissary, if any, operated in connection with the Store (and the real property to the extent applicable) or designate a substitute purchaser for the Store. We agree, however, to be responsible for and shall guarantee payment of any deferred portion of the purchase price as provided in Section 19.5 of this Agreement in the event we designate a substitute purchaser of the assets of the Store. If you do not execute and deliver any documents required, by execution of this Agreement you irrevocably appoint us as your lawful attorney-in-fact with full power and authority to execute and deliver in your name all these documents. You also agree to ratify and confirm all of our acts as your lawful attorney in fact and to indemnify and hold us harmless from all claims, liabilities, losses or damages suffered by us in so doing.

19.8 Operation During Option Period.

We will have the right, upon written notice to you, to manage, or designate one of our affiliates to manage, the Store during the period in which we have the option to purchase the Store as provided in section 19.1 and for the period following the exercise of our option and prior to the closing, on the same terms and conditions as described in Section 21.7.

19.9 Formula Price.

The parties agree that the formula price described in this Section 19 is the agreed upon method of arriving at a price for the assets of the Store in the event we exercise the option contained in this Section 19 and is not to be deemed a conclusive indication of the value of the Store under other circumstances or where an agreement to purchase the Store has been negotiated by you or your owners.

20. RESTRICTIVE COVENANTS.

20.1 In-Term Covenant.

In addition to all other obligations in the Agreement, you agree that, during the term of this Agreement, you or your owners will not, directly or indirectly for the benefit of you or your owners, or through or on behalf of or in conjunction with any other person, partnership or corporation, own, engage in, be employed by, advise, assist, invest in, franchise, make loans to, or have any other interest, whether financial or otherwise, in any other carry-out or delivery pizza store business (except for other Domino's Pizza Stores operated under franchise agreements entered into with us or other Domino's Pizza Stores in which you or your owners have an ownership interest).

20.2 Post-Term Covenant.

You agree that, for a period of one (1) year after termination or expiration of this Agreement, or the date on which you cease to operate the Store, whichever is later, you or your owners will not, directly or indirectly for the benefit of you or your owners, or through or on behalf of or in conjunction with any other person, partnership or corporation, own, engage in, be employed by, advise, assist, invest in, franchise, make loans to, or have any other interest, whether financial or otherwise, in any carry-out or delivery pizza store business located at the premises of the Store or within ten (10) miles of the premises of the Store (except for other Domino's Pizza Stores operated under franchise agreements with us or other Domino's Pizza Stores in which you or your owners shall have an ownership interest). The covenant contained in this section shall not be deemed to impair, modify or change any covenant not to compete contained in any agreement for the purchase and sale of the Store and shall be in addition to all other obligations you have under this Agreement to us or our affiliates upon termination or expiration of this Agreement.

20.3 Ownership of Public Companies.

The covenants contained in this Section 20 shall not apply to ownership of less than a five percent (5%) beneficial interest in the outstanding equity securities of any corporation whose stock is publicly traded.

20.4 Customer Lists and Trade Secrets.

You agree to maintain the absolute confidentiality of the Operating Manual and all other information concerning the Domino's System, whether provided by us or a third party, during and after the term of the franchise, disclosing this information to the other employees of the Store only to the extent necessary for the operation of the Store in accordance with this Agreement, and that you will not use the Operating Manual or such other information in any other businesses or in any manner not specifically authorized or approved by us in writing. The customer lists and all historical data relating to the sale of all pizza and beverage products at the Store (the "Customer Lists") also shall be deemed confidential and (a) you shall not use the Customer Lists in any other business or capacity; and (b) you shall maintain the absolute secrecy and confidentiality of the Customer Lists.

20.5 Owners of Approved Entity.

If you are an Approved Entity, the owners, by executing this Agreement, shall be bound by the provisions contained in this Agreement, including the restrictions set forth in this Section 20. Further, a violation of any of the provisions of this Agreement, including the covenants contained in this Section 20, by any owner shall also constitute a violation by you of your obligations under this Agreement.

20.6 Distribution of Products Related to the Domino's System.

During and after the term of this Agreement, you and your owners agree not to sell or otherwise distribute any products, or items bearing any of the Marks or which are used at any time in connection with any advertising, promotional or operational program other than to customers of your Store in the ordinary course of business or to another Domino's Pizza franchisee in good standing at the time of any proposed transfer approved by us.

20.7 Ownership Structure.

You, your owners and affiliates agree to fully comply with all rules, policies and procedures from time to time prescribed by us relating to the ownership structure of an Approved Entity. If you are an Approved Entity, you agree that the Controlling Person who has been approved by us will at all times during the term of this Agreement own and control fifty-one percent (51%) or more of the absolute voting and ownership interests of the Approved Entity, unless the Controlling Person obtains our prior written approval for a different ownership structure. You also agree to submit to us for our review and prior written approval any proposed change before attempting any change in the ownership or control of the Approved Entity or its affiliates, or any documents governing the ownership or control of the Approved Entity or its affiliates.

20.8 Non-Disclosure.

Except as may be required or permitted by applicable law, you agree that neither you nor your affiliates, owners, representatives, agents or employees will make any statements or communications, directly or indirectly, about us or our affiliates, officers, employees, franchisees (including you or your affiliates), businesses, properties, financial condition, sales trends, management, ownership, past or current business practices or strategies to any person, including, without limitation, the media or any financial analysts, whether verbally or in writing, including, without limitation, any communications or statements that would reasonably be expected to adversely affect our business or reputation or the Domino's System or shareholders of Domino's Pizza, Inc. or its affiliated companies.

20.9 Irreparable Injury and Injunctive Relief.

You acknowledge and agree that the provisions of this Section 20, including, without limitation, the provisions of Sections 20.1, 20.2, 20.5 and 20.9, are necessary to protect our legitimate business interests and the Domino's System, to prevent the unauthorized dissemination of marketing, promotional and other confidential information to our competitors and others outside of the Domino's System, to protect our trade secrets and the integrity of the Domino's System, and to prevent the duplication of the Domino's System. You also acknowledge and agree that damages

alone cannot adequately compensate us if there is a violation of these provisions by you or your owners, that we will suffer irreparable harm arising out of any such violation, and that injunctive relief against you and your owners is essential for the protection of us and our franchisees. Accordingly, we will have the right to petition a court of competent jurisdiction for injunctive relief against you and your owners without posting any bond or security whatsoever, in addition to all other remedies that may be available to us under this Agreement or applicable law.

21. ASSIGNMENT.

21.1 By DPF.

This Agreement is fully assignable by us and the assignee or other legal successor to our interests will be entitled to all of the benefits of this Agreement.

21.2 By Franchisee.

This Agreement is personal to you and your owners (if you are an Approved Entity). Accordingly, neither you nor any of your owners may assign or transfer this Agreement, any interest in this Agreement or, if you are an Approved Entity, any interest in an Approved Entity except as specifically authorized under this Agreement. A transfer of ownership of the Store (or its assets) may only be made in conjunction with a transfer of this Agreement. Any attempted assignment or transfer not in accordance with this Agreement shall have no effect and shall constitute a breach of this Agreement.

21.3 Assignment to an Approved Entity.

We will allow you to assign this Agreement and the Store (and its assets) to an Approved Entity for the convenience of ownership of the Store, provided:

- (a) the Approved Entity conducts no business other than the operation of the Store or other Domino's Pizza Stores (or other related activities authorized under this Agreement);
- (b) the Approved Entity is actively managed by you;
- (c) the person designated as the Controlling Person owns and controls not less than fifty-one percent (51%) of the general partnership interest of such partnership, the equity and voting power of all classes of issued and outstanding capital stock of such corporation, the membership interest in the limited liability company or the voting and ownership interests of such entity; and
- (d) all owners meet our requirements as established from time to time by us and agree to guarantee the obligations of the Approved Entity under this Agreement and to be bound by the terms of this Agreement in the manner prescribed by us.

If you are an Approved Entity or if this Agreement is assigned to an Approved Entity, you must comply with the requirements set forth in this Section 21.3 throughout the term of this Agreement. The organization documents of any Approved Entity owning the franchise, including

all stock certificates, shall recite that they are subject to all restrictions contained in this Agreement. We shall also have the right to require, as a condition of any assignment of this Agreement to an Approved Entity or the operation of the franchise by an Approved Entity, that the owners enter into a buy/sell agreement among themselves in a form and containing such terms as we prescribe for transfers of ownership interests in such Approved Entity. You shall provide us with all documents to be executed in connection with any such assignment and we shall use our reasonable efforts to approve or disapprove these within thirty (30) days after receipt.

21.4 Assignment or Transfer to Others.

We will permit sales, transfers or assignments of this Agreement or, if you are an Approved Entity, of an ownership interest in the Approved Entity to others provided:

- (a) you (and your owners) are not in default under this Agreement or any other agreement with us or our subsidiaries or affiliates or any other creditor or supplier of the Store;
- (b) the proposed transferee or assignee (and its Controlling Person and all other owners if it is an Approved Entity) meets our then applicable standards for franchisees or owners;
- (c) the proposed transferee or assignee (and its owners) is not engaged in any other business activity without our prior written consent, except other Domino's Pizza Stores;
- (d) the proposed transferee or assignee (and its owners if it is an Approved Entity) must sign our then-current form of standard franchise agreement for a term equal to the remaining term of this Agreement or, at our election, the then current term if longer;
- (e) the proposed transferee or assignee (or the person designated by us) must complete all required training to the extent required by us;
- (f) at our request, the proposed transferee or assignee refurbishes the Store in the manner and subject to the provisions prescribed in Sections 9 and 15;
- (g) the proposed transferee or assignee pays us a transfer fee of \$1,500.00; and
- (h) this Agreement is terminated according to the terms of our customary form of mutual termination agreement and customary form of release.

The provisions of (d), (e), (f), (g), and (h) above shall not apply to an approved sale, transfer or assignment by an owner owning a forty-nine percent (49%) or less interest in the Approved Entity except that the proposed transferee or assignee must guarantee the performance by Franchisee of its obligations under this Agreement and agree to be bound by all of the provisions of this Agreement in the form prescribed by us. You must provide us with all documents to be executed by you and/or your owners and the proposed purchasers in connection with any transfer or assignment at least thirty (30) days prior to signing.

21.5 Death or Permanent Disability.

Upon your death or permanent disability or the death or permanent disability of the Controlling Person, this Agreement or the ownership interest of such deceased or permanently disabled Controlling Person must be transferred to a party approved by us. Any transfer, including, without limitation, transfers by devise or inheritance or trust provisions, shall be subject to the same conditions for transfers which are contained in this Agreement. Except as otherwise prescribed by us in writing, your personal representative or the personal representative of such Controlling Person shall submit to us a proposal meeting the requirements for transfer of this Agreement or such ownership interest within one hundred and twenty days (120) days of your death or permanent disability or the death or permanent disability of such Controlling Person. We agree to communicate our approval or disapproval of any such proposal within fifteen (15) days of receipt. We will not unreasonably withhold our consent to the transfer of this Agreement or such ownership interest to your spouse, heirs or relatives or the spouse, heirs or relatives of such deceased or permanently disabled Controlling Person, provided the requirements of Section 21.4 are satisfied. Your personal representative or the personal representative of such deceased or permanently disabled Controlling Person shall complete the transfer of this Agreement or such ownership interest within sixty (60) days from the date of our approval of any such proposal. Upon the death of any other owner, the interest of such owner shall be transferred within a reasonable time to a person meeting our requirements. All such transfers must also comply with Section 21.4 of this Agreement. Your or any of your owners' failure to transfer the interest in accordance with the provisions of this Section shall be considered a breach of this Agreement.

21.6 Definition of Permanent Disability.

You or your Controlling Person, will be deemed to have a "permanent disability" if you or your Controlling Person's usual, active participation in the Store as contemplated by this Agreement is for any reason curtailed for a continuous period of six (6) months.

21.7 Operation by DPF After Death or Permanent Disability.

We shall have the right to appoint a manager for the Store if in our judgment the Store is not being managed properly after your death or permanent disability or the death or permanent disability of the Controlling Person. Our right to appoint a manager for the Store includes the right to temporarily or permanently cease operations at the Store, if in our reasonable judgment continued operation of the Store will adversely affect the Marks, the long term reputation of the Store or the Domino's System, or present a risk to public health, welfare and safety, including the well-being of the employees of the Store. All funds from the operation of the Store during the management by our appointed manager will be kept in a separate fund, and all expenses of the Store including compensation, other costs, and travel and living expenses of our manager will be charged to this fund. We will charge a management fee of five and one-half percent (5 1/2%) (in addition to the royalty fee and advertising contributions payable under this Agreement) during the period in which the Store is managed on your behalf. In managing the Store, our obligation will be to use our reasonable efforts to ensure the Store is properly managed, and neither we nor our affiliates will be liable for any debts, losses or obligations of the Store, to any of your creditors for any products, materials, supplies or services purchased by the Store prior to or during the time of management by our appointed manager. If the separate fund that is established is insufficient to

pay the expenses of the Store, we will notify you or your executor, administrator, conservator or other personal representative and this person must deposit in the fund within five (5) business days, any amount required by us to attain a reasonable balance in the fund.

21.8 Right of First Refusal of DPF.

If you or your owners propose to sell or transfer all or any part of the Store (or its assets) or, if you are an Approved Entity, any ownership interest in an Approved Entity and you or your owners obtain a bona fide, executed written offer to purchase or otherwise transfer or acquire this interest, you or your owners are obligated to deliver a copy of the bona fide offer to us along with all documents to be executed by you or your owners and the proposed assignee or transferee. Our right of first refusal shall commence upon the date of our receipt of the following: (i) the bona fide, executed written offer to purchase, transfer or acquire; (ii) all documents to be executed by you or your owners and the proposed assignee or transferee; (iii) all documents related to the operation of the Store which you are required to provide us, including, but not limited to a current copy of the lease for the Store and such financial statements as are required of you under Section 14.2 of this Agreement; and (iv) your notice that you are specifically submitting the documents to give us the right to exercise our right of first refusal, and shall continue for a period of thirty (30) days thereafter. Failure to submit any one or more of the items, including the notice of the purpose of the submission, shall result in our right of first refusal being extended until 30 days after we receive all of the required documents and the notice. We shall exercise the right to purchase or otherwise acquire the Store (or its assets) or such ownership interest for the price and on the terms and conditions contained in the offer by giving written notice to you or your owners. We may substitute equivalent cash for any form of payment proposed in such offer or designate a substitute purchaser or transferee for the Store (or the assets) or the ownership interest being offered, provided that we will assume responsibility for the performance of any other purchaser we may designate. If the offer is to purchase the interest of a Controlling Person and is for less than all of the outstanding interests of the Approved Entity, we shall also have the right, during the same period of time described above and upon written notice to the other owners, to purchase or otherwise acquire the remaining shares of capital stock, partnership interest or membership interest at a per share or per unit or interest price (or other terms) equivalent to the price (or other terms) being offered under the bona fide offer to the Controlling Person. If we do not exercise this right of first refusal, the offer may be accepted by you or your owners, subject to our prior written approval as provided in this Agreement. If the offer is not accepted by you or your owners, within sixty (60) days, we will again have the right of first refusal to purchase or otherwise acquire the Store as described above. This section will not apply to transfers made in accordance with Section 21.3 of this Agreement.

22. CONTRACT INTERPRETATION AND ENFORCEMENT.

22.1 Effect of Waivers.

No waiver by us of any breach or a series of breaches of this Agreement shall constitute a waiver of any subsequent breach or waiver of the performance of any of your obligations under this Agreement. Our acceptance of any payment from you or the failure, refusal or neglect by us or you to exercise any right under this Agreement or to insist upon full compliance with our or

your obligations under this Agreement or with any specification, standard or operating procedure or rule will not constitute a waiver of any provision of this Agreement.

22.2 Cost of Enforcement.

If any legal or equitable action is commenced, either to challenge, interpret, or to secure or protect our rights under or to enforce the terms of this Agreement, in addition to any judgment entered in our favor, we shall be entitled to recover such reasonable attorney's fees as we or anyone acting on our behalf may have incurred together with court costs and expenses of litigation.

22.3 Indemnification of DPF.

If we or any of our subsidiary or affiliated companies or any of our or their agents or employees are required to produce records or testify at trial or in deposition or are subjected to any claim, demand or penalty or become a party to any suit or other judicial or administrative proceeding brought by any person or persons (including your employee or prior employee) or any other person or entity by reason of any claimed act or omission by you, your employees or agents, or by reason of any act or omission occurring on the Store premises, or in your delivery service area, or while on the way to or from the delivery service area, by reason of an act or omission with respect to the business or operation of the Store, including but not limited to acts or omissions arising out of the maintenance or use of a motor vehicle or while making a delivery or returning from making a delivery, or any limitations on delivery service, you shall defend and indemnify and hold us, our subsidiary and affiliated companies, or any of our or their agents or employees, harmless against all judgments, settlements, penalties, and expenses, including attorney's fees, court costs and other expenses of litigation or administrative proceeding, incurred by or imposed on us, our subsidiary and affiliated companies, or any of our or their agents or employees, in connection with the testimony, production, investigation or defense relating to such claim or litigation or administrative proceeding. Your indemnification obligations described above will continue in full force and effect after, and notwithstanding, the expiration or termination of this Agreement.

22.4 Construction and Severability.

Section headings are for convenience only and shall not limit the enforceability or obligations contained therein. All references in this Agreement to the singular shall include the plural where applicable, and all references to the masculine shall include the feminine and vice-versa. If any part of this Agreement for any reason shall be declared invalid, such decision shall not affect the validity of any remaining portion, which shall remain in full force and effect. If any applicable law or rule requires a greater prior notice of the termination of or election not to renew this Agreement, or the taking of some other action than is required under this Agreement, the prior notice or other requirements required by this law or rule shall be substituted for the requirements of this Agreement. If any covenant in this Agreement which restricts competitive activity is deemed unenforceable by virtue of its scope in terms of area, business activity, prohibited and/or length of time, but would be enforceable by reducing any part or all thereof, the parties agree that same shall be enforced to the fullest extent permissible under the laws and public policies applied in the jurisdiction in which enforcement is sought. For purposes of this Agreement, the term "affiliate or affiliates" shall mean any entity or entities controlled by,

controlling, or under common control or common ownership with Franchisee (or any of its Owners) or DPF, as the case may be.

The rights and remedies of each party under this Agreement are cumulative, and no exercise or enforcement by a party of any right or remedy hereunder will preclude the exercise or enforcement of any other right or remedy hereunder.

22.5 Scope and Modification of Agreement.

This Agreement constitutes the entire agreement between the parties and supersedes all prior and contemporaneous, oral or written, agreements or understandings of the parties regarding the subject matter of this Agreement, provided that nothing in this Agreement or in any related agreement is intended to disclaim the representations we made in any franchise disclosure document we delivered to you in connection with this Agreement. Further, nothing in this Agreement or in any related agreement is intended to prevent or restrict you from contacting or communicating with any federal, state or local authorities or agencies about our compliance with any applicable laws, including franchise laws, or the relationship of the parties under this Agreement or any related agreement. No modification, waiver, termination, rescission, discharge or cancellation of this Agreement shall affect the right of any party to enforce any claim or right under this Agreement, whether or not liquidated, which occurred prior to the date of such modification, waiver, termination, rescission, discharge or cancellation.

22.6 Governing Law.

The terms and provisions of this Agreement shall be interpreted in accordance with and governed by the laws of the State in which the Store is located.

22.7 Notices.

All written notices permitted or required to be delivered by the provisions of this Agreement or of the Operating Manual shall be deemed so delivered when delivered to you or the Store by: (i) hand delivery; (ii) three (3) days after having been placed in the United States Mail by Registered or Certified Mail; (iii) one (1) day after being placed in the hands of a commercial courier service for next day delivery; or (iv) one (1) day after transmission by facsimile or other electronic system (including via e-mail and including e-mails which you are the only addressee or one of multiple addressees). Notices delivered pursuant to this section including, without limitation, e-mail, shall be addressed to us at our most current principal business address or to you at the most current principal business address, e-mail address or home address of which we have been notified in writing. You are obligated to provide us with a correct current address for your home and business and to notify us of any change in address within ten (10) business days. If you maintain an e-mail address for your business you agree to provide us with your business e-mail address and notify us of any change in your e-mail address within ten (10) business days. You understand and agree that providing us with notice of changes in addresses (including e-mail address) shall be made in the manner provided in this section for giving notices. If you fail to timely notify us of a change of address (including e-mail, business or home), all notices sent to the prior address will be deemed properly delivered.

22.8 Independent Contractors.

The parties to this Agreement are independent contractors and no training, assistance or supervision which we may give or offer to you shall be deemed to negate such independence or create a legal duty on our part. Neither we nor any of our affiliates shall be liable for any damages to any person or property arising directly or indirectly out of the operation of the Store, including but not limited to those damages which may occur while your employees are making or returning from making deliveries, or arising out of your delivery service policies. Nor shall we or any of our affiliates have any liability for any taxes levied upon you, your business, or the Store. The parties further acknowledge and agree the relationship created by this Agreement and the relationship between us is not a fiduciary relationship nor one of principal and agent. Furthermore, neither we nor our affiliates have any relationship with your employees and have no rights, duties, or responsibilities with regard to their employment by you. You acknowledge and agree that you do not have the authority to act for or on our behalf or to contractually bind us or our affiliates to any agreement. No party to this Agreement shall have any authority to assume any liability for the acts of the other, or to alter the legal relationships of the other. Only the named parties to this Agreement shall have rights hereunder and you shall not have any rights under any other franchise agreement to which you are not a party.

22.9 Standard of Reasonableness.

Unless otherwise stated in this Agreement, we agree to exercise reasonable judgment with respect to all determinations to be made by us under the terms of this Agreement.

22.10 Acknowledgments.

(a) The following acknowledgments are made by and binding upon all franchisees signing this Agreement, except those franchisees and franchises that are subject to the state franchise registration/disclosure laws in California, Hawaii, Illinois, Indiana, Maryland, Michigan, Minnesota, New York, North Dakota, Rhode Island, South Dakota, Virginia, Washington, or Wisconsin:

(i) You acknowledge that you have read this Agreement and our Franchise Disclosure Document and been given an opportunity to obtain clarification of any provision that you did not understand.

(ii) You acknowledge that you have conducted an independent investigation of the business contemplated by this Agreement and recognize that it involves business risks making the success of the venture largely dependent upon your business abilities.

(iii) We expressly disclaim the making of, and you acknowledge that you have not received or relied upon, any warranty or guarantee, express or implied, as to the potential volume, profits or success of the business venture contemplated by this Agreement.

(b) You acknowledge that you have conducted an independent investigation of the Store's delivery and service area and are familiar with the boundaries and the nature and extent of any areas that might present a danger to you or your employees. In addition, you acknowledge

and agree that this Agreement may not be modified, amended or changed except by a writing signed by all parties. You also acknowledge that this Agreement has been executed by us in the State of Michigan and that this Agreement is to be performed in part through services rendered in the State of Michigan.

22.11 Binding Effect.

This Agreement is binding upon the parties and their heirs, approved assigns and successors in interest.

22.12 No Waiver or Disclaimer of Reliance in Certain States.

The following provision applies only to franchisees and franchises that are subject to the state franchise registration/disclosure laws in California, Hawaii, Illinois, Indiana, Maryland, Michigan, Minnesota, New York, North Dakota, Rhode Island, South Dakota, Virginia, Washington, or Wisconsin:

No statement, questionnaire, or acknowledgement signed or agreed to by you in connection with the commencement of the franchise relationship shall have the effect of (i) waiving any claims under any applicable state franchise law, including fraud in the inducement, or (ii) disclaiming reliance on any statement made by DPF, any franchise seller, or any other person acting on behalf of DPF. This provision supersedes any other term of any document executed in connection with the franchise.

22.13 Effective Date of this Agreement.

This Agreement shall become effective upon the date of its acceptance and execution by us.

DOMINO'S PIZZA FRANCHISING LLC

FRANCHISEE:

By: _____
Colleen McCormick

By: _____

Its: Sr. Manager – Regulatory Affairs and
Contracts

Its:

DATED: _____

DATED: _____

DATE OF STORE OPENING

[THIS PAGE INTENTIONALLY LEFT BLANK]

COVENANTS OF OWNERS

The undersigned individuals (the "Owners") represent and warrant to DPF that they are all of the owners of Franchisee or otherwise have a direct or indirect interest in the success of Franchisee and that the person designated below as the Controlling Person is the Controlling Person of the Approved Entity under this Agreement. Further, to induce DPF to enter into this Agreement and grant the franchise to Franchisee, each of the Owners, on behalf of themselves and each of their affiliates, hereby jointly and severally guarantees the performance by Franchisee of its obligations under this Agreement and agrees to be bound by all of the provisions of this Agreement, including, without limitation, the restrictions contained in Sections 20 and 21 of this Agreement, provided that the liability of the Owners and their affiliates to DPF under their guarantee, other than the Controlling Person and his or her affiliates, shall be based upon the percentage of such Owner's ownership interest in Franchisee.

Each Owner acknowledges and agrees that:

(1) The Approved Entity shall be managed solely by the Controlling Person and that the Controlling Person may not be removed by any action of the Approved Entity or its Owners without the prior written consent of DPF;

(2) The Controlling Person shall at all times during the continuation of this Agreement have not less than fifty one percent (51%) of the equity and voting power and/or interests in the Approved Entity unless otherwise approved in writing by DPF and any provision or term in the governing or establishing documents for the Approved Entity or any agreement between the Owners to the contrary is and shall be void for all purposes;

(3) The establishing or governing documents for the Approved Entity do not provide for a "supermajority" or other voting structure that would require the Controlling Person to have more than 51% of the equity and voting structure in order to maintain control over the Approved Entity and that no Owner(s) has any type of "veto" rights and that no voting trusts have been established which would restrict or limit the voting control of the Controlling Person. If such provision or term exists in the establishing or governing documents or other agreements, the Owners agree that it shall be void for all purposes;

(4) The Controlling Person has, as of the date of execution of this Agreement, the option, but not the obligation, exercisable on thirty (30) days notice, to purchase any or all of the equity and voting interest owned by the other Owners for a sum certain which has been determined prior to the execution of this Covenant of Owners (which may be modified by the Owners). If for any reason all Owners have not agreed upon a purchase price, the undersigned Owner(s) agree that the purchase price for their interest shall be the fair market value for all of the Domino's Pizza Stores, Domino's Pizza Non-Traditional and Domino's Pizza Transitional Stores which the Approved Entity operates as determined by an independent appraiser selected by the Controlling Person and the Owners holding a majority of the remaining interests. If the Controlling Person and the Owners holding a majority of the remaining interests cannot agree on an independent appraiser, the Controlling Person shall select an independent appraiser and the

Owners holding a majority of the remaining interests shall select an independent appraiser and those two (2) appraisers shall select a third independent appraiser. The third independent appraiser selected by the two (2) appraisers shall determine the fair market value of the equity and voting interest owned by the Owners and the determination of the third independent appraiser shall be final and binding on all parties. If an independent appraiser is not selected through this process within sixty (60) days, DPF shall have the right to select an independent appraiser whose determination of the fair market value shall be binding and final on all parties and DPF shall incur no liability for doing so. The result of such computation shall be multiplied by the ratio that the Owner's interest bears to all outstanding ownership interests in the Approved Entity. Upon tendering the purchase price for each Owner's interest, the Owners hereby agree to convey such interest and such commitment shall be subject to enforcement by any court of competent jurisdiction through specific performance;

(5) If the Controlling Person receives a bona-fide offer and desires to sell the franchise, the Franchisee can require the other Owners to sell his/her interest in accordance with the terms of the bona-fide offer.

(6) None of the Owners has given, received or taken any security interest in this Agreement or any pledge of any equity or interest in the Approved Entity and no such security interest or pledge shall be given, received or taken during the continuation of this Agreement;

Each Owner also acknowledges and agrees, on behalf of such Owner and each of their affiliates, that DPF may apply any monies DPF may owe to any Owner or any of his/her affiliates, including, without limitation, from any profit sharing arrangements, to satisfy or offset amounts owed by Franchisee or any Owner or their affiliates to us or our affiliates under the Franchise Agreement or any other agreement. Each Owner also acknowledges and agrees, on behalf of himself/herself and each of their affiliates, that DPF shall have recourse against and be entitled to pursue the assets of any other Domino's Pizza store owned by such owner and his or her affiliates to recover or satisfy any amounts owed by Franchisee or any Owner or their affiliates to us or our affiliates under the Franchise Agreement or any other agreement.

These Covenants of Owners are intended to modify and supersede any provisions of the establishing or governing documents for the Approved Entity or other agreement between the Owners which are inconsistent with its terms. In the event of any inconsistency between these Covenants of Owners and any other agreement or governing or establishing document, these Covenants of Owners shall control. The undersigned acknowledge that the execution of these Covenants of Owners are conditions to approval by DPF of assignment or entry of this Agreement with DPF, and DPF shall be entitled to refuse to acknowledge or recognize any provisions of the governing or establishing documents of the Approved Entity which are inconsistent with the terms of these Covenants of Owners or this Agreement. Each of the Owner(s) agree that in the event that any of the governing or establishing documents for the Approved Entity are inconsistent with the provisions of these Covenants of Owners, the Controlling Person is granted the authority and power to modify or amend such provision and each Owner agrees to cast any necessary vote in favor of the amendment of such document or to execute such agreement as will reconcile these Covenants of Owners and the applicable document or agreement. The undersigned further agree

that the governing and establishing documents of the Approved Entity shall not be amended, modified, deleted, novated or otherwise changed in any manner without the prior written consent of DPF.

<hr/>	<hr/>
CONTROLLING PERSON	% of Ownership
<hr/>	<hr/>
N/A	N/A
OWNER:	% of Ownership
<hr/>	<hr/>
N/A	N/A
OWNER:	% of Ownership
<hr/>	<hr/>
N/A	N/A
OWNER:	% of Ownership

**RIDER (FOR RESIDENTS OF ILLINOIS)
TO THE DOMINO'S PIZZA FRANCHISING LLC
STANDARD FRANCHISE AGREEMENT
BETWEEN DOMINO'S PIZZA FRANCHISING LLC AND**

DATED _____, _____

1. Section 22, Paragraph 22.6 of the Standard Franchise Agreement is hereby amended to read as follows:

22.6 **Governing Law.** The terms and provisions of this Agreement shall be interpreted in accordance with and governed by the laws of the State in which the Store is located or by the laws of the State in which you reside. However, if the jurisdictional requirements of the Illinois Franchise Disclosure Act are met independently without reference to this Paragraph; then this Agreement (and its validity, interpretation and construction), any claims arising from this Agreement, and the relationship between us and you will be governed by the laws of the State of Illinois.

DOMINO'S PIZZA FRANCHISING LLC

FRANCHISEE:

By: _____
Colleen McCormick

By: _____

Its: Sr. Manager – Regulatory Affairs and
Contracts

Its: President

**RIDER (FOR RESIDENTS OF MARYLAND) TO THE DOMINO'S PIZZA
FRANCHISING LLC
STANDARD FRANCHISE AGREEMENT**

This Rider is made and entered into as of _____ (this "Agreement") by and between _____, a _____ ("Franchisee") and **DOMINO'S PIZZA FRANCHISING LLC**, a Delaware limited liability company ("Domino's").

1. **BACKGROUND.** Domino's and Franchisee are parties to that certain Standard Franchise Agreement dated _____ that has been signed concurrently with the signing of this Rider. This Rider is annexed to and forms part of the Standard Franchise Agreement. This Rider is being signed because (a) Franchisee is a resident of Maryland, or (b) the Domino's Pizza Store will be located or operated in Maryland.

2. **RELEASES.** The following language is added to the end of the first sentence of Sections 3.1(d) and the end of Section 21.4(h) of the Standard Franchise Agreement:

; provided, however, that such general release shall not apply to any liability under the Maryland Franchise Registration and Disclosure Law.

3. **ACKNOWLEDGMENTS.** The following language is added to the end of Section 22.10 of the Standard Franchise Agreement:

Such representations are not intended to nor shall they act as a release, estoppel or waiver of any liability incurred under the Maryland Franchise Registration and Disclosure Law.

IN WITNESS WHEREOF, the parties have signed this Rider as of the dates set forth by their signatures, to be effective as of the Effective Date.

DOMINO'S PIZZA FRANCHISING LLC

FRANCHISEE:

By: _____

By: _____

Its: _____

Its: _____

DATED: _____

DATED: _____

**RIDER (FOR RESIDENTS OF MINNESOTA)
TO THE DOMINO'S PIZZA FRANCHISING LLC
STANDARD FRANCHISE AGREEMENT
BETWEEN DOMINO'S PIZZA FRANCHISING LLC AND**

DATED _____, _____

1. The following language is hereby added to Section 22, Paragraph 22.4 of the Standard Franchise Agreement:

"Minnesota law provides franchisees with certain termination and non-renewal rights. Minn. Stat. Sec. 80C.14, Subd. 3, 4 and 5 require, except in certain specified cases, that a franchisee be given ninety (90) days notice of termination (with sixty (60) days to cure) and one hundred eighty (180) days notice for non-renewal of the Agreement."

DOMINO'S PIZZA FRANCHISING LLC

FRANCHISEE:

By: _____
Colleen McCormick

By: _____

Its: Sr. Manager – Regulatory Affairs and
Contracts

Its: President

**RIDER (FOR RESIDENTS OF NORTH DAKOTA)
TO THE DOMINO'S PIZZA FRANCHISING LLC
STANDARD FRANCHISE AGREEMENT
BETWEEN DOMINO'S PIZZA FRANCHISING LLC AND**

DATED _____, _____

1. The following language is hereby added to Section 20, Paragraph 20.2 of the Standard Franchise Agreement:

"Covenants not to compete upon termination or expiration of the Franchise Agreement are generally unenforceable in the State of North Dakota."

2. Section 22, Paragraph 22.2 of the Standard Franchise Agreement, entitled Cost of Enforcement, is hereby amended to read as follows:

"22.2 **Cost of Enforcement**. The prevailing party in any enforcement action shall be entitled to recover all costs and expenses, including attorneys' fees."

DOMINO'S PIZZA FRANCHISING LLC

FRANCHISEE:

By: _____
Colleen McCormick

By: _____

Its: Sr. Manager – Regulatory Affairs and
Contracts

Its: President

WASHINGTON STANDARD FRANCHISE AGREEMENT ADDENDUM

The following language is added to the end of the Standard Franchise Agreement:

In the event of a conflict of laws, the provisions of the Washington Franchise Investment Protection Act, Chapter 19.100 RCW will prevail.

RCW 19.100.180 may supersede the franchise agreement in your relationship with the franchisor including the areas of termination and renewal of your franchise. There may also be court decisions which may supersede the franchise agreement in your relationship with the franchisor including the areas of termination and renewal of your franchise.

In any arbitration or mediation involving a franchise purchased in Washington, the arbitration or mediation site will be either in the state of Washington, or in a place mutually agreed upon at the time of the arbitration or mediation, or as determined by the arbitrator or mediator at the time of arbitration or mediation. In addition, if litigation is not precluded by the franchise agreement, a franchisee may bring an action or proceeding arising out of or in connection with the sale of franchises, or a violation of the Washington Franchise Investment Protection Act, in Washington.

A release or waiver of rights executed by a franchisee may not include rights under the Washington Franchise Investment Protection Act or any rule or order thereunder except when executed pursuant to a negotiated settlement after the agreement is in effect and where the parties are represented by independent counsel. Provisions such as those which unreasonably restrict or limit the statute of limitations period for claims under the Act, or rights or remedies under the Act such as a right to a jury trial, may not be enforceable.

Transfer fees are collectable to the extent that they reflect the franchisor's reasonable estimated or actual costs in effecting a transfer.

Pursuant to RCW 49.62.020, a noncompetition covenant is void and unenforceable against an employee, including an employee of a franchisee, unless the employee's earnings from the party seeking enforcement, when annualized, exceed \$100,000 per year (an amount that will be adjusted annually for inflation). In addition, a noncompetition covenant is void and unenforceable against an independent contractor of a franchisee under RCW 49.62.030 unless the independent contractor's earnings from the party seeking enforcement, when annualized, exceed \$250,000 per year (an amount that will be adjusted annually for inflation). As a result, any provisions contained in the franchise agreement or elsewhere that conflict with these limitations are void and unenforceable in Washington.

RCW 49.62.060 prohibits a franchisor from restricting, restraining, or prohibiting a franchisee from (i) soliciting or hiring any employee of a franchisee of the same franchisor or (ii) soliciting or hiring any employee of the franchisor. As a result, any such provisions contained in the franchise agreement or elsewhere are void and unenforceable in Washington.

The undersigned does hereby acknowledge receipt of this addendum.

Dated this _____ day of _____ 20_____.

FRANCHISOR

FRANCHISEE

This addendum may also be used as a rider to the Franchise Disclosure Document.

EXHIBIT F

NON-TRADITIONAL STORE FRANCHISE AGREEMENT

Store #

DOMINO'S PIZZA FRANCHISING LLC
NON-TRADITIONAL STORE
FRANCHISE AGREEMENT

Franchisee

[THIS PAGE INTENTIONALLY LEFT BLANK]

TABLE OF CONTENTS

1. INTRODUCTION 7

2. GRANT AND TERM OF FRANCHISE..... 8

 2.1 Grant 8

 2.2 Term of Franchise 8

3. RENEWAL OF FRANCHISE..... 8

 3.1 Option to Renew 8

 3.2 Manner of Renewal..... 9

 3.3 Notification of Expiration..... 9

4. TERRITORIAL RIGHTS AND OBLIGATIONS 10

 4.1 Area of Primary Responsibility 10

5. OPENING ADVERTISING AND PROMOTION EXPENDITURE 10

6. ROYALTY FEE AND OTHER CHARGES..... 10

 6.1 Amount and Payment..... 10

 6.2 Definition of Royalty Sales..... 10

 6.3 Interest on Late Payments..... 10

 6.4 Electronic Funds Transfer..... 11

 6.5 Application of Payments..... 11

7. STORE LOCATION 11

 7.1 Location and Use 11

 7.2 Relocation; Damage, or Condemnation..... 12

 7.3 Location and Operation of Commissary..... 12

 7.4 Store Lease..... 12

 7.5 Assumption of Lease on Termination or Expiration..... 13

 7.6 Ownership of Store Premises..... 13

8. STORE DEVELOPMENT 13

 8.1 Development and Construction..... 13

 8.2 Equipment, Fixtures, Furniture and Signs. 14

 8.3 Store Opening 14

9. STORE REFURBISHING..... 14

10. TRAINING 15

 10.1 Initial Training 15

10.2	Training of Employees.....	15
10.3	Additional Training.....	16
11.	OPERATING ASSISTANCE.....	16
11.1	Advice and Guidance	16
11.2	Operating Problems	16
12.	STORE PRODUCTS	17
12.1	Store Menu.....	17
12.2	Pizza Ingredients, Supplies and Materials	17
13.	ADVERTISING AND PROMOTION	17
13.1	By DPF.....	17
13.2	Local and Regional Advertising Cooperatives	18
13.3	By Franchisee.....	19
14.	RECORDS AND REPORTS	19
14.1	Bookkeeping and Recordkeeping	19
14.2	Sales Reports and Financial Statements	20
14.3	Right to Require Audit.....	21
15.	OPERATING REQUIREMENTS	22
15.1	Operating Procedures.....	22
15.2	Compliance with Laws and Other Business Practices	23
15.3	Pricing.....	24
15.4	Operating Manual	24
15.5	New Concepts	24
15.6	Franchisee Must Directly Supervise Store.....	24
15.7	Insurance	25
15.8	Identification as Franchisee	26
15.9	Computer Hardware and Software and Other Technology.....	26
15.9.1	Brand Technology.....	26
15.9.2	Aggregate Expenditures for Brand Technology	28
15.9.3	Domino's PULSE and Other Computer & Technology Training	28
15.9.4	Additional Order Processing Systems	28
16.	MARKS	29
16.1	Usage.....	29
16.2	Infringements	29

16.3	Indemnification	29
17.	INSPECTIONS	29
18.	TERMINATION AND EXPIRATION	30
18.1	Termination By Franchisee.....	30
18.2.1	Immediate Termination By DPF -- Upon Written Notice	30
18.2.2	Termination By DPF -- After Opportunity to Cure	32
18.2.3	Immediate Cessation of Operations	32
18.3	Obligations Upon Termination or Expiration	33
19.	OPTION TO PURCHASE STORE	34
19.1	Option	34
19.2	Formula Price.....	34
19.3	Purchase of Commissary.....	34
19.4	Deductions From Purchase Price	35
19.5	Payment of Purchase Price.....	35
19.6	Real Property	36
19.7	Closing	36
19.8	Operation During Option Period.....	37
19.9	Formula Price.....	37
20.	RESTRICTIVE COVENANTS	37
20.1	In-Term Covenant.....	37
20.2	Post-Term Covenant	37
20.3	Ownership of Public Companies	38
20.4	Customer Lists and Trade Secrets.....	38
20.5	Owners of Approved Entity	38
20.6	Distribution of Products Related to the Domino's System	38
20.7	Ownership Structure	38
20.8	Non-Disclosure	39
20.9	Irreparable Injury and Injunctive Relief	39
21.	ASSIGNMENT	39
21.1	By DPF.....	39
21.2	By Franchisee.....	39
21.3	Assignment to an Approved Entity	40
21.4	Assignment or Transfer to Others.....	40

21.5	Death or Permanent Disability	41
21.6	Definition of Permanent Disability	42
21.7	Operation by DPF After Death or Permanent Disability	42
21.8	Right of First Refusal of DPF	42
22.	CONTRACT INTERPRETATION AND ENFORCEMENT	43
22.1	Effect of Waivers	43
22.2	Cost of Enforcement	43
22.3	Indemnification of DPF	43
22.4	Construction and Severability	44
22.5	Scope and Modification of Agreement	44
22.6	Governing Law	45
22.7	Notices	45
22.8	Independent Contractors	45
22.9	Standard of Reasonableness.....	46
22.10	Acknowledgments.....	46
22.11	Binding Effect.....	46
22.12	No Waiver or Disclaimer of Reliance in Certain States	46
22.13	Effective Date of this Agreement	47

DOMINO'S PIZZA FRANCHISING LLC

NON-TRADITIONAL STORE FRANCHISE AGREEMENT

This Non-Traditional Store Franchise Agreement, including the Covenants of Owners (this "Agreement") is being entered into between Domino's Pizza Franchising LLC, a Delaware liability company ("we", "DPF" or "us" in this Agreement), and

"you" or "franchisee" in this Agreement). If you are a corporation, partnership, limited liability company or other entity approved by us (the "Approved Entity"), the term "owners" in this Agreement shall refer to your shareholders, affiliates, partners, members or other interest holders. Unless otherwise approved by DPF, the term "Controlling Person" refers to the person who owns fifty one percent (51%) or more of: the general partnership interest of such partnership; the equity and voting power of all classes of the issued and outstanding capital stock of such corporation; the membership interests of such limited liability company or the voting and ownership interests of such other entity.

1. INTRODUCTION.

We are in the business of franchising retail outlets specializing in the sale of pizza and other authorized food and beverage products and featuring carry out and delivery services. These outlets are known as "Domino's Pizza" stores and conduct business under a uniform business format, with specially designed equipment, computer hardware and software designated by us, and specifications for the preparation and sale of pizza and certain authorized food products (the "Domino's System"). We have obtained the license to use and the right to sublicense the use of certain valuable trademarks, service marks and commercial symbols in connection with the operation of Domino's Pizza Stores including the mark "Domino's Pizza." We grant franchises for the sale of Domino's Pizza and other authorized products and services at or from nontraditional locations and venues, alternative sites and mobile stores utilizing the Domino's System. These locations are identified as Domino's Pizza Pizzazz Stores, Domino's Pizza C Stores, Domino's Pizza Express Stores, Domino's Pizza Micro Market Stores or other names associated with Domino's Pizza depending upon the site, location or venue (individually or collectively known as "Domino's Pizza Non-Traditional Store(s)").

You have applied to us for a franchise to operate a Domino's Pizza Non-Traditional Store at the location identified in this Agreement using the trademarks, service marks and commercial symbols as we may approve or designate from time designate (the "Marks.") Your application has been approved by us in reliance upon all of the representations made in your application including those concerning your financial resources, your other investments and interests and the manner in which the franchise will be owned and operated.

You understand and agree that the terms and conditions contained in this Agreement are necessary to maintain our high standards of quality and service and the uniformity of those standards.

You understand that a Domino's Pizza Non-Traditional Store is intended to serve a certain niche market by offering carry-out service only, with dine in facilities only at such times and locations as we may from time to time approve in advance. Domino's Pizza Non-Traditional Stores do not offer delivery services.

2. GRANT AND TERM OF FRANCHISE.

2.1 Grant.

Subject to the terms of this Agreement, DPF grants to you a franchise to operate a Domino's Pizza Non-Traditional Store (the "Store") and a sublicense to use the Marks at the following location:

Store # at: _____

Except as otherwise provided herein, you understand that your rights are non-exclusive and that nothing in this Agreement shall entitle you to any rights to operate a Store at any other location or to prohibit DPF to operate or franchise the operation of a Domino's Pizza Store, Domino's Pizza Non-Traditional Store or any other retail outlet at any other site, location or venue.

2.2 Term of Franchise.

The term of this Agreement shall be for a period of ten (10) years, commencing on the date of opening of the Store (or if this Agreement is being signed in connection with a renewal or transfer of the franchise, commencing on the day following the expiration or termination of the previous franchise agreement, as the case may be).

3. RENEWAL OF FRANCHISE.

3.1 Option to Renew.

You may, at your option, renew the franchise for one additional ten (10) year term, provided:

- (a) you are not in material default of any provision of this Agreement or any other agreement with us or our subsidiaries or affiliates or any other creditor or supplier of the Store and have substantially complied with the terms and conditions of these agreements during their terms. For purposes of this Section 3.1(a), "substantial compliance" shall mean that you have not (i) breached or violated the terms of this Agreement on six (6) or more occasions during the term of this Agreement or on three (3) or more occasions during the last twenty four (24) months prior to the expiration of the term of this Agreement regardless of whether or not you cured any such breach or violation, or (ii) engaged in any conduct or act described in Section 18.2.1 of this Agreement at any time during the term of this Agreement regardless of whether or not you cured any such breach or violation;

(b) you refurbish the site as provided in Sections 9 and 15 of this Agreement or, if we require, agree to relocate the premises of the Store to a location approved by us and develop the premises in accordance with our then current requirements. If we require you to relocate the premises of the Store, you will be entitled to credit the costs of developing the new premises toward any refurbishing obligations you may have under the franchise agreement executed in connection with such renewal; and

(c) subject to applicable laws, you and your owners agree to execute a general release, in a form then prescribed by us, of any claims arising out of this Agreement against us and our affiliates, and our and their officers, directors, managers, agents, representatives and employees.

This option to renew may not be exercised unless all of the preceding conditions are fully satisfied. The option to renew is personal to you and may not be exercised by any other person or entity without our prior written consent.

3.2 Manner of Renewal.

The new franchise agreement you must execute to renew the franchise shall be our then current form of standard franchise agreement. You must also sign all other agreements we customarily require at the time of the renewal of the franchise. You understand that the renewal franchise agreement may provide for higher royalty fees and greater expenditures for advertising and promotion than are provided for in this Agreement and may contain other terms materially different from the terms of this Agreement. The area of primary responsibility of the Store, if any, will not be modified unless such modification is consistent with criteria then in effect for comparable market areas. There will be no initial franchise or similar fee charged upon a renewal of the franchise. You will also be entitled to renew the franchise at the end of the renewal term in accordance with the renewal provisions, if any, contained in the franchise agreement executed by you in connection with your renewal of the franchise.

3.3 Notification of Expiration.

Provided you are in compliance with this Agreement, including the provisions of Section 3.1, we will send all agreements relating to renewal of the franchise for your review and execution approximately six (6) months prior to the expiration of this Agreement along with a notification of the expiration of this Agreement. Your failure to return these agreements to us within thirty (30) days of receipt will be deemed an election by you not to renew this Agreement. Our notice will also state what actions, if any, you must take to correct the deficiencies in your operation of the Store or whether we will require you to relocate or refurbish the premises of the Store as provided in Section 3.1 above. We also will specify the time period in which these deficiencies must be corrected or by which the refurbishing or relocation and development of the new premises must be completed, provided that, in the event that the then current term of your lease or any renewal lease does not expire concurrently with the expiration of this Agreement, we will not require you to complete a relocation of your Store and development of the new premises until the expiration of the then current term of your lease or any renewal lease or other instrument or agreement granting you the right to occupy the premises of the Store. If we require you to

relocate the Store, our notice will identify the reasons for requiring relocation. Renewal of the franchise will be conditioned on your continued compliance with all the terms and conditions of this Agreement and all other agreements with us and our affiliates and subsidiaries and all other creditors and suppliers of the Store up to the date of expiration.

4. TERRITORIAL RIGHTS AND OBLIGATIONS.

4.1 Area of Primary Responsibility.

The premises of the Store will be your Area of Primary Responsibility

Provided you are in compliance with the terms of this Agreement, and except as otherwise provided in Section 4.3, neither we nor our affiliates will not operate or grant a franchise for the operation of a Domino's Pizza Non-Traditional Store during the term of this Agreement whose area of primary responsibility overlaps your Area of Primary Responsibility.

5. OPENING ADVERTISING AND PROMOTION EXPENDITURE.

If you (or the Controlling Person if you are an Approved Entity) are opening your (or his or her) first Domino's Pizza Store, Domino's Pizza Pizzazz Store or Domino's C Store, you must submit to us proof no later than ninety (90) days after opening of the Store that you have spent at least Three Thousand Dollars (\$3,000.00) on grand opening advertising and promotion.

6. ROYALTY FEE AND OTHER CHARGES.

6.1 Amount and Payment.

During the term of the franchise, you agree to pay us a royalty fee of five and one half percent (5½%) of the weekly royalty sales of the Store. This fee must be paid by Thursday of each week on royalty sales for the week ending on the preceding Sunday. Payment must be made by electronic funds transfer as provided in Section 6.4 below or as we may otherwise designate from time to time.

6.2 Definition of Royalty Sales.

The term "royalty sales" means the total receipts from all sales by the Store of all pizza, beverages and other products or services authorized for sale at the Store or at any approved off site location but exclusive of sales or equivalent taxes, coupon and similar discounts, and beverage container deposits approved by us. Premium or similar promotional items must be included in computing royalty sales unless these items have been sold at or below cost by the Store. Premium or similar promotional items shall not be deemed to include any food or beverage item unless otherwise specified to us.

6.3 Interest on Late Payments.

All royalty fees, advertising contributions and all other amounts owed to us pursuant to this Agreement will bear interest after the due date at the rate of one and one half percent (1½%) per

month or at the highest legal rate for open account business credit in the state in which the Store is located, whichever is lower.

6.4 Electronic Funds Transfer.

You must participate in an electronic funds transfer program under which royalty fees and advertising contribution payments are deducted or paid electronically from your bank account. We may permit you to initiate payments via a system established or approved by us, or at our option, require you to authorize us to initiate debit and/or credit entries and/or credit correction entries to your Store bank operating account (the "Account") for payment of royalty fees and advertising contributions on forms we prescribe. In the event you are required to authorize us to initiate debit entries, you agree to make the funds available in the Account for withdrawal by electronic transfer no later than the due date for payment. The amount actually transferred from the Account to pay royalty fees and advertising contributions will be based on the Store's royalty sales reported to us. If you have not reported royalty sales of the Store to us for any reporting period, we will be authorized to debit the Account in an amount equal to the royalty fee transferred from the Account for the last reporting period for which a report of the royalty sales of the Store was provided to us. If at any time we determine that you have under reported the royalty sales of the Store or underpaid royalty fees or advertising contributions due us under this Agreement, we will be authorized to initiate immediately a debit to the Account in the appropriate amount in accordance with the foregoing procedure, including interest as provided for in this Agreement. An overpayment will be credited to the Account through a credit effective as of the first reporting date after we and you determine that such credit is due. Our use of electronic funds transfers as a method of collecting royalty fees and advertising contributions due us does not constitute a waiver of any of your obligations to provide us with weekly sales reports as provided in Section 14.2 nor shall it be deemed a waiver of any of the rights and remedies available to us under this Agreement. If, for any reason other than your fault or neglect, the electronic funds transfer program in which we require you to participate is not functioning so as to allow you to pay the amounts due under this Agreement to us, you may seek permission from us to make payment by mail for the period of time that the electronic funds transfer system is not functioning. If we grant permission for you to make payment by mail, we will specify the day by which payment must be postmarked and paid for any week on royalty sales for the week ending on the preceding Sunday.

6.5 Application of Payments.

When we receive a payment from you, we have the right in our sole discretion to apply it as we see fit to any past due indebtedness of yours due to us or our affiliates, whether for royalties, advertising contributions, purchases, interest, or for any other reason, regardless of how you may designate a particular payment to be applied. In addition, we may offset any amount otherwise due under any discount or rebate program against any amount owed to us.

7. STORE LOCATION.

7.1 Location and Use.

You may operate the Store only at the location specified in Section 2.1 and you may not relocate the Store except with our prior written consent. The Store premises may only be used for

the operation of a Domino's Pizza Non-Traditional Store and other related activities approved by us in writing. You shall not allow the premises of the Store to be used for any purpose which in our judgment, adversely affects the reputation of the Store or the goodwill associated with the Marks or involves dishonesty, fraud, deceit, illegal conduct, misrepresentation, or moral turpitude.

7.2 Relocation; Damage, or Condemnation.

In the event the Store is destroyed or rendered unusable, we may grant permission for the Store to be repaired, restored or reconstructed at the existing location. Any repair, restoration, reconstruction or relocation will be at your sole expense. The Store, whether we grant permission for you to repair, restore, reconstruct or relocate, must be open and operating no later than six (6) months after its closure. In addition, within ten (10) days of vacating the Store premises, you must make such reasonable modifications to the exterior and interior of the Store (including signage, menu boards, job aids, product photos, and the like) as we require to fully eliminate its identification and appearance as a Domino's Pizza Store. If you fail or refuse to fully de-identify the Store to the extent and in the manner required by this Agreement, we may, at our option and in addition to other rights and remedies we may have, make the modifications that are contemplated by this Agreement on your behalf and you agree to promptly pay and reimburse us on demand for any costs incurred by us including, without limitation, the proportionate compensation of our employees who devote time and render services in the de-identification of the Store.

7.3 Location and Operation of Commissary.

Any commissary operated by you in connection with the Store may be located only at the premises of the Store or other premises approved by us in writing and must be operated in accordance with commissary standards prescribed by us from time to time. Such commissary must be owned by you and operated by you and your employees exclusively for the benefit of the Store or other Domino's Pizza Stores or Domino's Pizza Non-Traditional Stores owned by you and may not be owned or operated by any other person or entity without our prior written consent. You may not open or operate a commissary unless you have received prior written notification from us that you have satisfied in advance all of our requirements for the operation of a commissary, including all required training of commissary personnel.

7.4 Store Lease.

Unless otherwise agreed to by us in writing, if the property on which the Store is located is not owned by you, you must maintain a lease for the site of the Store (including the lease for the site of the commissary, if any, to be operated by you in connection with the Store) which shall contain such terms as we specify from time to time for all leases of a similar type. Each original lease, renewal leases and lease addenda and modification of any type must be submitted to us prior to execution for our examination and approval that it contains the terms we require in all leases. You must provide us with a copy of the executed lease, any renewal lease, and any addenda and modification or other instrument or agreement governing occupancy of the premises within thirty (30) days after execution by you and the landlord.

7.5 Assumption of Lease on Termination or Expiration.

Upon the termination or expiration of the franchise for any reason, other than a termination by you for cause, we or our designee shall have the right to assume or designate one of our affiliates to assume, your status and replace you as lessee or occupant of the premises. You agree to execute an assignment of your interest in the lease promptly upon our request. Upon exercise of our or our affiliate's right to assume your status as lessee, and your compliance with the other provisions of this section, you will be fully released and discharged from all liability for rent and all other future liability under the lease or the instrument or agreement by which you occupy the premises (although not from any liability for unpaid rent or charges or any other then existing liability to the lessor or owner, including, without limitation, any damages to the premises or restoration costs). If we exercise our right to assume, or have our affiliates assume your lease or other instrument or agreement by which you occupy the premises, we will indemnify you and hold you harmless against any claim made for future rent or charges or other future liability under the lease or instrument or agreement. We will also notify you within ninety (90) days of obtaining your written assignment of your interest in the lease of any damages to the premises or restoration costs for which you are liable or responsible.

7.6 Ownership of Store Premises.

If you, or any entity that you own or control, owns any interest in the real estate where the Store is located, you agree to furnish to us upon request, a copy of the deed and any other document relating to the title to the real estate and a copy of your owner's policy of title insurance.

8. STORE DEVELOPMENT.

8.1 Development and Construction.

You agree that promptly after obtaining possession of the site for the Store you will:

- (a) cause to be prepared and submit for approval by us a site plan for the Store, including requirements for dimensions, design, materials, interior layout, equipment, fixtures, furniture, signs, and decorating. You understand that you may modify our plans and specifications only to the extent required to comply with applicable ordinances, building codes, permit requirements and lease or occupancy requirements and only with our prior written approval;
- (b) obtain all required zoning changes; all required building, utility, health, sanitation, and sign permits and any other required permits;
- (c) purchase or lease fixtures, furniture and signs meeting our specifications or requirements and, if we so require, from an approved vendor or vendors designated by us;
- (d) acquire through purchase, lease and/or license the Brand Technology as required by Section 15.9.1.

(e) complete the construction and/or remodeling, equipment, fixture, furniture and sign installation and decorating of the Store in full and strict compliance with plans and specifications approved by us and all applicable ordinances, building codes, permit and lease or occupancy requirements;

(f) obtain all customary contractors' sworn statements and partial and final waivers of lien for construction, remodeling, decorating and installation services; and,

8.2 Equipment, Fixtures, Furniture and Signs.

We will provide you with specifications for pizza, other authorized food and beverage preparation, dispensing, storage and display equipment, other equipment, fixtures, furniture, exterior and interior signs and decorating that we require you to use or install in the Store. We may specify brands, types or models for any of these items. You may purchase items meeting our specifications from any source unless we designate an approved source or sources for any of these items. If you propose to purchase or lease items not previously approved by us as meeting our specifications or from a vendor not approved by us, you must first notify us and we may require submission of sufficient specifications, photographs, drawings and/or other information and samples to determine whether any such item or supplier meets our specifications or our approved vendor criteria. We will advise you within a reasonable time whether any proposed item or vendor meets our specifications or our approved vendor criteria. You agree to use only such items that meet our specifications in the operation of the Store and to purchase them from approved vendors, if we so require. You understand, however, that we or our affiliates or an approved vendor may be the only source for some of these items and that we may otherwise limit the number of approved vendors. We reserve the right to charge you for our reasonable expenses in testing and/or evaluating any proposed item or vendor submitted by you.

8.3 Store Opening.

You agree to complete development of the Store and have the Store ready to open within a reasonable time after obtaining possession of the site for the Store and in accordance with the lease or other agreement for occupancy of the premises. If you do not open the Store within six (6) months from the effective date of this Agreement, we will have the option to terminate this Agreement upon the giving of written notice to you.

9. STORE REFURBISHING.

You have an obligation to maintain the Store in a manner which contributes positively to the then current image of the Domino's Pizza brand. You agree to refurbish the Store (in addition to regular maintenance and repair), within six (6) months of receipt of written notice from us, as we may from time to time require to maintain or improve the appearance and efficient operation of the Store, to increase its sales potential or to comply with our then current standards, image or identity. Refurbishing may include:

(a) replacement of worn out or obsolete equipment, fixtures, furniture and signs;

- (b) the substitution or addition of new or improved equipment, including safes, fixtures, furniture, and signs designated by us;
- (c) redecorating;
- (d) renovation of the interior and exterior of the premises and restoration and resurfacing of parking facilities; and
- (e) structural modifications and remodeling of the premises.

You will not be required to make aggregate expenditures for refurbishing of the Store in excess of one and one half percent (1-1/2%) of the royalty sales of the Store from the date of its opening to the date of any required refurbishing not to exceed the ten (10) year period prior to the date of any such required refurbishing or, except in connection with a renewal of the franchise, to effect any refurbishing of the Store during the last twelve (12) months of the initial term of the franchise unless required to do so by the lease or other instrument or agreement for occupancy of the premises of the Store.

For purposes of this Section 9, the term equipment shall not include computer hardware or other components of the Brand Technology (as defined in Section 15.9.1). Any additions, substitutions, replacements or modifications to the Brand Technology shall be governed by the provisions of Sections 15.9.1. and 15.9.2 of this Agreement.

10. TRAINING.

10.1 Initial Training.

If you (or the Controlling Person if you are an Approved Entity) have not previously opened either a Domino's Pizza Store or Domino's Pizza Non-Traditional Store you or the Controlling Person must enroll and complete all training programs and classes which we require for the operation of the Store. These training programs and classes will be furnished at such times and places as we designate. We have the right to charge a reasonable training fee for these training programs or classes. All training programs and classes must be completed to our satisfaction. You will be responsible for the travel, living expenses and any other costs incurred during these training programs and classes.

10.2 Training of Employees.

You agree to implement a training program for employees of the Store and to be solely responsible for training the employees to legally, safely and properly perform his or her duties while inside the Store and while outside the Store for business purposes, including training your employees to follow appropriate procedures for their safety and well being as well as the safety and well-being of the public. You agree not to employ any person who fails or refuses to complete your training programs or is unqualified to perform his or her duties in accordance with the requirements established for the operation of a Store. You acknowledge and understand that implementing a training program for employees of the Store and training your employees to follow safe and proper procedures for the operation of the Store will remain your sole responsibility even if, from time to time, you obtain advice, certifications or suggestions from us or our affiliates about

these topics. You further acknowledge and understand that it is not our responsibility or duty to implement a training program for your employees, nor do we have the responsibility or duty to instruct your employees about matters of safety and security in or around the Store or on the way to or from the Store. By providing advice, certifications or suggestions, we do not assume any of your responsibilities or duties.

10.3 Additional Training.

We may also, at our option, require you (or the Controlling Person if you are an Approved Entity) to attend supplemental or additional training programs which may be offered from time to time by us or our affiliates during the term of the franchise. The fee for such training shall range from between One Hundred Dollars (\$100.00) and Five Hundred Dollars (\$500.00) per training class. You will be responsible for the reasonable costs of such programs and for the travel and living expenses and any other costs incurred during these programs. You must complete this supplemental or additional training within one (1) year of the time in which it is originally offered by us or our affiliates.

11. OPERATING ASSISTANCE.

11.1 Advice and Guidance.

We will furnish you with such reasonable operating assistance as we determine from time to time to be necessary for the operation of the Store. Operating assistance will include advice and guidance regarding:

- (a) methods of pizza, other authorized food and beverage preparation, packaging and sale; and
- (b) the establishment of administrative, bookkeeping, accounting, inventory control and general operating procedures.

You acknowledge and understand that it is not our responsibility or duty to operate the Store and we do not have the legal right to direct your employees in the operation of the Store. Those functions remain your sole responsibility and duty. Further, you understand that the assistance provided to you under this Section 11 does not obligate us to provide the accounting, bookkeeping, administrative, inventory control or marketing services required for the operation of the Store or to otherwise operate the Store. By providing advice or suggestions, we do not assume any of your responsibilities or duties.

11.2 Operating Problems.

We will advise you from time to time of operating problems of the Store disclosed by reports submitted to or inspections made by us or our designee. We will make no separate charge for operating or marketing assistance except that we may make reasonable charges for forms and other materials supplied to you and for operating assistance made necessary in our judgment as a result of your failure to comply with any provision of this Agreement or for operating assistance requested by you in excess of that normally provided by us. By providing advice, certifications or suggestions, we do not assume any of your responsibilities or duties.

12. STORE PRODUCTS.

12.1 Store Menu.

You agree that you will offer for sale and sell at the Store for final consumption and not for resale, all pizza, other authorized food and beverage products that we from time to time authorize; provided, however, you may offer for resale authorized products for certain programs approved by us. Such approval will not be unreasonably withheld and the decision to approve shall be based upon: (i) quality assurance; (ii) brand image; (iii) and such other factors as we determine. You also agree that you will not offer for sale or sell at the Store any other products or services.

12.2 Pizza Ingredients, Supplies and Materials.

All pizza and other food ingredients, beverage products, cooking materials, containers, packaging materials, other paper and plastic products, utensils, uniforms, menus, forms, cleaning and sanitation materials and other supplies and materials used in the operation of the Store must conform to the specifications and quality standards established by us from time to time. You must use in the operation of the Store, boxes, containers and other paper or plastic products imprinted with the Marks as prescribed from time to time by us. We may in our sole discretion require that ingredients, supplies and materials used in the storage, preparation, packaging, and delivery of pizza and other authorized food products be purchased exclusively from us, our affiliates or from approved suppliers or distributors. You agree to request delivery of food products to the Store in quantities and in a manner that is consistent with policies prescribed from time to time by us. Any ingredient, supply or material not previously approved by us as conforming to our specifications and quality standards must be submitted for examination and/or testing prior to use. We reserve the right from time to time to examine the facilities of any approved supplier or distributor, including the commissary operated by you, if any, and to conduct reasonable testing and inspection of the ingredients, materials or supplies to determine whether they meet our standards and specifications. We also reserve the right to charge fees for testing and evaluating proposed suppliers or distributors and examining and inspecting commissary operations and to impose reasonable limitations on the number of approved suppliers or distributors of any product. Approval of a supplier or distributor may be conditioned on requirements relating to frequency of delivery and standards of service including prompt attention to complaints and the ability to service and supply Stores within areas designated by us.

13. ADVERTISING AND PROMOTION.

13.1 By DPF.

We or our designee will from time to time formulate, develop, produce and conduct advertising and promotional programs in the form and media as we or our designee determines to be most effective. You agree to participate in all national and local and regional advertising and promotions as we determine to be appropriate for the benefit of the Domino's Pizza System. We reserve the right, in our sole discretion, to determine the composition of all geographic territories and market areas for the development and implementation of advertising and promotion programs. All costs of the formulation, development and production of any such advertising and promotion

(including without limitation the proportionate compensation of our employees who devote time and render services in the formulation, development and production of such advertising and promotion programs or the administration of the funds), will be paid from an advertising fund administered by a separate not for profit entity for all Domino's Pizza Stores and Domino's Pizza Non-Traditional Store provided, however, that we may at any time in our sole discretion set up a separate advertising fund for Domino's Pizza Non-Traditional Stores (these funds are hereinafter designated as the "Advertising Fund"). You will be obligated to pay up to four percent (4%) of the weekly royalty sales of the Store to the Advertising Fund as we may designate from time to time. Your advertising contribution must be postmarked on Monday and paid by Wednesday of each week on royalty sales for the week ending on the preceding Sunday or by Thursday, if paid by electronic funds transfer as provided in Section 6.4 of this Agreement. All Domino's Pizza Non-Traditional Stores owned by us or our affiliates will contribute to the cost of such advertising and promotion programs on at least the same basis as you. We will submit to you upon request an annual statement of monies collected and costs incurred by the Advertising Fund. We reserve the right to engage the services of an advertising source or sources to formulate, develop, produce and conduct the advertising and promotion programs, the cost of such services to be payable from the Advertising Fund.

You acknowledge and understand that all such advertising is intended to maximize general public recognition and patronage of the Marks in the manner determined to be most effective by us and our affiliates and that neither we nor our affiliates undertake any obligation in developing, implementing or administering these programs to ensure that expenditures which are proportionate or equivalent to your contributions are made for the market area of the Store or that of any Domino's Pizza Pizzazz Store will benefit directly or pro rata from the placement of advertising.

13.2 Local and Regional Advertising Cooperatives.

We reserve the right to require that you participate in local and regional advertising cooperatives administered by us or our affiliate or by other franchisees of the Domino's System or in the event no such cooperative has been established, to require you to conduct local advertising for your Store. In addition to the advertising contribution payable by you under Section 13.1, you agree to pay any contributions that we require you to make for expenditures by these local or regional cooperatives or that may be otherwise approved by these cooperatives or for local advertising if no cooperative exists. If there is no advertising cooperative or if the Stores participating in a cooperative have not agreed upon a percentage of royalty sales to be contributed to the cooperative, you must expend or contribute to the cooperative, respectively, an amount we specify up to and including two percent (2%) of royalty sales. If a cooperative exists and sixty-five percent (65%) or more of the Stores agree to contribute or are contractually obligated to contribute a specified percentage of royalty sales to the cooperative, then we can require you to make the same percentage contribution to the cooperative as the other Stores in the cooperative. All Domino's Pizza Stores participating in a cooperative shall contribute no less than 2% of royalty sales. All Stores which are contractually obligated to contribute the specified percentage of royalty sales voted upon by the cooperative shall be counted as a favorable vote, whether or not they attend or vote at the meeting. We agree that the maximum aggregate amount we can obligate you to contribute for advertising and promotion under this Section 13.2 and Section 13.1 will be nine percent (9%) of the royalty sales of your Store. All contributions payable under this Section 13.2 must be paid by Thursday of each week on royalty sales for the week ending on the preceding

Sunday. Payment must be made by electronic funds transfer as provided in Section 6.4 of this Agreement or as we may otherwise designate from time to time. Nothing contained in this Section 13.2 shall limit, affect or supersede any obligation on your part to contribute a greater percentage of the royalty sales of the Store pursuant to any separate agreement or understanding you may have with any such local or regional advertising or promotional cooperative. We reserve the right on our behalf and on behalf of our affiliates to engage the services of an advertising source or sources to formulate, develop, produce and conduct the advertising and promotion programs for the cooperatives or for local advertising if no cooperatives exists with the cost of these services payable from the cooperative advertising budget or contributions made by you in accordance with this provision.

13.3 By Franchisee.

All of your advertising, promotions and media relations, including, but not limited to, all public relations, social media, events and all advertising and promotions conducted by you or your employees whether through public appearances or in print, or on radio, television, the Internet, and other electronic media ("Your Advertising"), must be completely factual and shall conform to the highest standards of ethical advertising and be consistent with the then current image and policies and obligations relating to advertising and promotional programs of a Domino's Pizza Non-Traditional Store. In the event Your Advertising, in our judgment, is deemed to be inappropriate in any way, you shall immediately terminate or remove Your Advertising upon receipt of notice from us. We do not assume any of your duties and responsibilities related to Your Advertising.

14. RECORDS AND REPORTS.

14.1 Bookkeeping and Recordkeeping.

You agree to establish and retain a bookkeeping, recordkeeping, computer and point of sale system (including a record of the names, addresses, telephone numbers and order history of the customers in your Store's delivery area all in form and format designated by us) conforming to the requirements prescribed by us, relating, without limitation, to the use and retention of daily sales information, counts of pizza types and other approved menu items sold, coupons, purchase orders, purchase invoices, payroll records, check stubs, bank statements, sales tax records and returns, cash receipts and disbursements, checks and credit card sales, journals and general ledgers, including any comparable electronically generated information or any supporting records or materials we may require or prescribe. You agree to retain all business records and reports (whether paper or electronically generated) relating to the Store in accordance with record retention policies and guidelines prescribed by us, from time to time, and for the time limits required by all applicable laws, ordinances and regulations. You also agree to maintain an emergency back up order taking system and other back up operational procedures identified by us in accordance with policies and procedures we may prescribe from time to time. You agree that we shall have full access, either on-site or from a remote location, to all of your computer data, equipment and systems containing any and all of the information, records and reports required by this Section 14.1 or any other provision of this Agreement or any other agreement with our affiliates. In addition, you agree to provide us with access to all such data, equipment and systems

to facilitate the exchange of information you are required to provide us under this Agreement. Any information provided by you shall be used by us in a lawful manner.

14.2 Sales Reports and Financial Statements.

You agree to submit to us, in accordance with requirements prescribed by us from time to time and in a format which we may designate from time to time:

(a) with the royalty fee due, a weekly report of the sales of the Store and all other information and supporting records as we may require;

(b) within sixty (60) days of the end of each fiscal year of the Store:

(i) a statement of cash flow and cash on hand, an unaudited balance sheet as of the end of the year and an unaudited annual statement of profit and loss and financial condition of the Store prepared on an accrual basis;

(ii) if you are a corporation, partnership or other approved entity, a statement of cash flow and cash on hand, an unaudited balance sheet as of the end of the month and an unaudited statement of profit and loss of the corporation, partnership or other approved entity prepared on an accrual basis;

(iii) if you have additional Domino's Pizza Stores or Domino's Pizza Non-Traditional Stores a consolidated statement of profit and loss for all of your operations, including any additional Domino's Pizza Stores, Domino's Pizza Pizzazz Stores or Domino's Pizza C Stores which you own and all administrative and commissary operations. The statements must be prepared in accordance with generally accepted accounting principles by an accountant in the manner prescribed by us;

(c) promptly upon our request and within twenty (20) days of the end of the month or period, in the manner as we may prescribe, and continuing for such period of time as we may from time to time designate:

(i) a statement of cash flow and cash on hand, an unaudited balance sheet as of the end of the month or period and an unaudited statement of profit and loss of the Store prepared on an accrual basis for each month or period;

(ii) if you are a corporation, partnership or other approved entity, a statement of cash flow and cash on hand, an unaudited balance sheet as of the end of the month or period and an unaudited statement of profit and loss of the corporation, partnership or other approved entity prepared on an accrual basis for each month or period; and

(iii) a consolidated statement of profit and loss for all of your Domino's Pizza Stores for each month or period;

(d) if you are in default under any of the terms or conditions of this Agreement, statements submitted on a quarterly basis affirming that all federal, state and local taxes have been paid;

(e) upon our written request, exact copies of your and your owners federal, state and local business income tax returns and state sales tax or equivalent tax returns for any period; and

(f) such other information as we may reasonably require to determine you and your owners' compliance with this Agreement or to assist you in the operation of the Store or to otherwise evaluate the performance of the Store, including information about the sales and receipts of the Store.

14.3 Right to Require Audit.

We reserve the right to audit or cause to be audited the sales reports, financial statements, tax returns, information from the Store's computer system, and any other records you are required to retain or submit to us. In the event any audit discloses an understatement of the royalty sales of the Store for any period or periods (regardless of whether the understatement is intentional or not), we shall have the right to require that you pay on the amount of such understatement the royalty fee of five and one half percent (5½%), all advertising contributions due under this Agreement and the amount, if any, required to be paid to your local or regional cooperative as provided in this Agreement, plus interest due. Further, in the event such understatement for any period or periods shall be two percent (2%) or more of the royalty sales of the Store or such inspection or audit is made necessary by your intentional or negligent underreporting (including, without limitation, underreporting that arises out of your insufficient supervision of your employees) or your failure to furnish reports, supporting records, financial statements or other information required by this Agreement or to furnish these reports, records, information or financial statements on a timely basis, you will be obligated to reimburse us for the cost of the audit, including the charges of any independent certified public accountant used and the travel expenses, room and board and compensation of our employees or anyone we engage to conduct the audit. In the event you dispute the results of any audit conducted by us or our representatives, you will have the right, upon written notice to us within ten (10) days of your receipt of the results of our audit, to have the results verified by an independent certified public accounting firm selected by our outside accounting firm. The expense of this audit shall be borne by you unless this further audit discloses that no deficiency is due in which case we will be obligated to pay for the audit. We will notify you within ten (10) days of our receipt of your notice when the independent audit will commence. You agree to cooperate with all personnel conducting the audit. The results of the independent audit shall be binding upon the parties. You agree to pay any deficiencies within ten (10) days after receipt of our audit or, if applicable, the independent audit requested by you. You acknowledge and agree that conducting an audit as authorized by this section is one but not the only way we may determine or establish that you have underreported the royalty sales of the Store for any period or periods. You and your owners agree to fully comply and cooperate with any and all audits, including, but

not limited to, you, your owners and your employees treating our personnel in a professional manner.

15. OPERATING REQUIREMENTS.

15.1 Operating Procedures.

You agree to fully comply with all specifications, standards and operating procedures and rules from time to time prescribed for the Store, including, but not limited to, specifications, standards and operating procedures and rules relating to:

(a) the safety, maintenance, cleanliness, sanitation, function and appearance of the Store premises and its equipment, (including computer hardware, software, peripheral devices, high speed broadband connectivity, high speed broadband monitoring, and methods and means of encryption and access to our network resources), image, fixtures, furniture, décor and signs;

(b) qualifications, dress, grooming, general appearance and demeanor of you and your employees, including, but not limited to, engaging in any conduct which, in our judgment, adversely affects the reputation of the Store or the Domino's System or the goodwill associated with the Marks or involves dishonesty, fraud, deceit, illegal conduct, misrepresentation or moral turpitude;

(c) quality, taste, portion control and uniformity, and manner of storage, preparation and sale, of all pizza and other authorized food and beverage products sold by the Store and of all ingredients, supplies and materials used in the storage, preparation, packaging and sale of these items;

(d) methods and procedures relating to receiving, preparing, delivering and storing customer orders, including without limitation, online ordering;

(e) the hours during which the Store will be open for business;

(f) use and illumination of exterior and interior signs, posters, displays, menu boards and similar items;

(g) the handling of customer complaints;

(h) advertising on the Internet or other electronic media, including websites, home pages and use of domain names;

(i) e-mail capabilities of the Store and other electronic communication methods (including high speed broadband connectivity, high speed broadband monitoring, and methods and means of encryption and access to our network resources) and devices to facilitate communication with us or our offices, including the exchange of information between the Store and us; and

(j) the method and manner of payment which will be accepted from customers.

You acknowledge that specifications, standards or procedures may differ for a Domino's Pizza Store and Domino's Pizza Non-Traditional Store. By entering into this Agreement, you agree to abide by these specifications, standards, operating procedures and rules and to fully adopt and implement them.

15.2 Compliance with Laws and Other Business Practices.

You agree to secure and maintain in force all required licenses, permits and certificates and operate the Store in full compliance with all applicable laws, ordinances and regulations. You also agree to pay when due all amounts payable pursuant to any provision of this Agreement or any other agreement with us or our affiliates or subsidiaries or pursuant to any agreement with any other creditor or supplier of the Store. You shall file all tax returns and pay all taxes before they become delinquent. You agree not to permit any levy or warrant to be issued by any taxing authority or other creditor (excluding mechanics liens and other immaterial liens), against any of your assets, nor allow any of your assets to be seized or frozen by any taxing authority or other creditor. Furthermore, if you are subject to any withholding taxes on royalty fees or other payments, you shall provide us with quarterly evidence that such tax has been remitted to the appropriate governmental agency on a quarterly basis.

You agree to abide by the Payment Card Industry Data Security Standards enacted by the applicable Card Associations, applicable to your business. If you know or suspect a security breach, you shall immediately notify us. You shall promptly identify and remediate the source of the compromise. You assume all responsibility for providing all notices of breach or compromise and all duties to monitor credit histories and transactions concerning your customers. Without limiting the generality of other provisions of this Agreement, you agree to defend, indemnify and hold us and our affiliates harmless from and against any and all claims, demands, duties, obligations, damages, fines and/or penalties imposed upon you as a result of non-compliance with the Payment Card Industry requirements.

You and your owners acknowledge that Executive Order 13224 (the "Executive Order") prohibits transactions with terrorists and terrorist organizations and that the government of the United States has adopted and may in the future adopt other anti-terrorism measures (the "Anti-Terrorism Measures"). You certify that neither you or your owners nor any of your employees, affiliates or any other person or entity associated with the Store is: (1) a person or entity listed in the Annex to the Executive Order; (2) a person or entity otherwise determined pursuant to the Executive Order to have committed acts of terrorism or to pose a significant risk of committing acts of terrorism (such a person or entity and those persons and entities listed in the Annex to the Executive Order are referred to herein as "Terrorists"); (3) a person or entity who assists, sponsors or who supports Terrorists or acts of Terrorism ("Sponsors of Terrorism"); or (4) owned or controlled by Terrorists or Sponsors of Terrorism. Furthermore, you covenant that neither you or your owners, nor any of your employees, affiliates or any other person or entity associated with the Store shall, during the term of this Agreement, become a person or entity described in clause (1), (2) or (3) above, or shall otherwise become a target of any Anti-Terrorism Measures. Should you or any of your owners, employees, affiliates, or any person or entity associated with the Store,

violate the provisions of this paragraph, we will have the right to immediately terminate this Agreement.

15.3 Pricing.

We reserve the right, to the fullest extent allowed by applicable law, to establish maximum, minimum, or other pricing requirements with respect to the prices you may charge for products and services, including pricing we prescribe from time to time for any national, regional or local advertising or promotion.

15.4 Operating Manual.

We will loan to you during the term of the franchise one or more copies of an operating manual or operational bulletins or similar materials containing mandatory and suggested specifications, standards and operating procedures and rules prescribed from time to time by us and information relative to your other obligations under this Agreement and the operation of the Store (the "Operating Manual"). We will provide you with a manual or access to an electronic copy of the Operating Manual. The entire contents of the Operating Manual will remain confidential and is proprietary to us and our affiliates. We will have the right to add to and otherwise modify the Operating Manual from time to time, if deemed necessary to improve the standards of service or product quality or the efficient operation of the Store, to protect or maintain the goodwill associated with the Marks, to take advantage of advancements in technology, or to meet competition. No such addition or modification, however, shall alter your fundamental status and rights under this Agreement. The provisions of the Operating Manual as modified from time to time, including the mandatory specifications, standards and operating procedures and rules prescribed from time to time by us and communicated to you in writing, will constitute provisions of this Agreement as if contained in this Agreement.

15.5 New Concepts.

If you develop any new concept, process or improvement or any slogan in the operation or promotion of the Store, or technology used in connection with the operation of the Store, you agree to promptly notify us and provide us with all necessary information without compensation. You acknowledge that any such concept, process or improvement or slogan shall become our property and that we may utilize or disclose this information to other franchisees.

15.6 Franchisee Must Directly Supervise Store.

The Store shall at all times be under the direct, on premises supervision of you (or the Controlling Person if you are an Approved Entity). You (or the Controlling Person if you are an Approved Entity) must devote full time and efforts (excluding reasonable vacation periods) as manager of the Store or to the management of other Domino's Pizza Stores or Domino's Pizza Non-Traditional Stores (or other related activities approved by us in accordance with Section 7.1 of this Agreement). You shall be solely responsible for recruiting, hiring, training, scheduling for work, supervising and paying the persons who work in the Store and those persons shall be your employees, and not our agents or employees. Further, neither you nor any of your owners may, during the term of this Agreement, without our prior written consent, which may be withheld in our sole judgment, (i) engage, or own any interest, in any other business activity, (ii) be employed

by any other business, (iii) engage in any activity which may impair your ability to fulfill your obligations under this Agreement or (iv) engage in any conduct which, in our judgment, adversely affects the reputation of the Store or the Domino's System or the goodwill associated with the Marks or involves dishonesty, fraud, deceit, illegal conduct, misrepresentation or moral turpitude.

If you own more than one Store, each Store must also be under the direct, on premises supervision of a manager, whose conduct (including, without limitation, acts or failure to act) you will be responsible for, and:

(a) who has been properly trained by you on all specifications, standards, operating procedures and rules from time to time prescribed for the operation of a Domino's Pizza Store including, without limitation, proper reporting of royalty sales;

(b) whose identity has been disclosed to us; and

(c) who shall have executed, upon our request, an agreement in the form provided by us agreeing not to divulge any trade secret or confidential or proprietary information, including the contents of the Operating Manual, or to engage in or have any interest in any other carry out or delivery pizza store business.

15.7 Insurance.

You shall at all times during the term of the franchise maintain in force at your sole expense:

(a) property insurance on a replacement cost basis at a minimum limit based on the total value of your assets (including, but not limited to, fire, extended coverage, vandalism and malicious mischief),

(b) general liability insurance with a minimum limit of \$1,500,000.00 per occurrence (including, but not limited to, coverage for personal injury, products and contractual liability),

(c) automobile liability insurance with a minimum limit of \$1,500,000.00 per occurrence (including, but not limited to, owned automobiles titled or leased in the name of you or your owners and used at any time, whether principally or occasionally in your business, hired and non-owned coverage). If you or your owners do not use a vehicle owned or leased in the name of you or any of your owners in your business, you must provide written evidence of that fact, satisfactory to us; and

(d) workers' compensation insurance (in your name) as required by applicable law. If no such law exists, then you must participate in such other comparable insurance or benefit programs for your employees as required by us. If your state recognizes and permits self-insurer programs, your participation in such program will satisfy our requirements under this subsection (d). If deductible plans

are approved and used in your state, coverage may be purchased on this basis subject to the requirements of your insurance carrier.

All liability insurance policies must name us, and any subsidiaries and affiliates which we designate, as additional insureds entitled to the coverage afforded to all named insureds, without regard to any other insurance or self insured program which we or our affiliates may have in effect, and also provide that we receive thirty (30) days prior written notice of termination, expiration, cancellation, modification or reduction in coverage or limits of any such policy. The terms and conditions of all such policies, including the amount of any deductibles, shall be consistent with the requirements prescribed from time to time by us. You agree to promptly pay when requested by the insurer the amount of the deductible applicable to, and in the event of , any covered loss.

All insurance policies (excluding workers' compensation policies) must be issued by an insurance carrier rated B+ or better by Alfred M. Best & Company, Inc. or meeting such other rating or criteria we may establish from time to time. We may also reasonably increase the minimum liability "limit" protection requirement annually and require different or additional kinds of insurance to reflect inflation, changes in standards of liability, higher damage awards in public, product or motor vehicle litigation or other relevant changes in circumstances. You must submit to us annually a copy of the certificate of insurance or evidence of the renewal or extension of each such insurance policy or any modifications to any such insurance policies, which must describe the applicable deductibles for each such policy. If at any time you fail or refuse to maintain in effect any insurance coverage required by us, or to furnish satisfactory evidence of such insurance, we may, at our option and in addition to our other rights and remedies we may have, obtain insurance coverage, on your behalf, and you agree to promptly execute any applications or other forms or instruments required to obtain any such insurance and pay to us on demand any costs and premiums incurred by us. Your obligation to obtain and maintain the insurance described in this Agreement shall not be limited in any way by reason of any insurance maintained by us.

15.8 Identification as Franchisee.

You agree to exhibit on the Store premises signs of sufficient prominence and wording as we may prescribe from time to time so as to advise the public that the Store is owned, operated and maintained by you. All business cards, letterheads and other business materials shall clearly identify that you are the owner of the Store in accordance with the rules or policies we may establish from time to time in the Operating Manual or otherwise in writing. In addition, subject to rules and policies that may be established from time to time, all local advertising, including yellow page listings and advertisements that are placed by you or on your behalf, and which do not contain phone numbers or addresses that are associated with stores that we own or operate, shall either indicate that you are the owner of the store or stores in the print material, or that the store or stores are locally owned and operated.

15.9 Computer Hardware and Software and other Technology.

15.9.1 Brand Technology.

You agree to use in the development and operation of the Store the management system and computer hardware and software and related technology designated by us, including without

limitation, features such as high speed broadband connectivity, high speed broadband monitoring, online ordering, methods and means of encryption and access to our network resources, and other internet based technology and peripheral devices that we specify from time to time (the "Brand Technology"). You acknowledge that we may modify all aspects and the components of the Brand Technology from time to time. As part of the Brand Technology, we may require you to obtain computer hardware and/or software we specify from a single vendor designated by us and we or our affiliates may be the sole supplier of all or any part of the Brand Technology. You agree to use only such items and services as we specify in connection with the Brand Technology. We may require that you enter into a license exclusively with us or our affiliates to use proprietary software developed by or for us. You may also be required to enter into agreements with others for use of third party software incorporated or used in connection with the Brand Technology. Our modification of such specifications or components for the Brand Technology may require you to incur costs to purchase, lease and/or license new or modified computer hardware and/or software and to obtain service and support for the Brand Technology during the term of this Agreement. You acknowledge that the cost to you of obtaining the Brand Technology (including software licenses) (or additions, substitutions, replacements or modifications thereto) may not be fully amortizable over the remaining term of this Agreement. Nonetheless, subject to the provisions of Section 15.9.2 below, you agree to incur such costs in connection with obtaining the computer hardware and software comprising the Brand Technology (or additions, substitutions, replacements or modifications thereto). You further acknowledge and agree that we have the right to charge reasonable fees for software or systems modifications and enhancements specifically made for us that are licensed to you and other maintenance and support services that we or our affiliates furnish to you related to the Brand Technology. You may also incur charges from third parties who render services or provide products that we require you to purchase or use. We shall have independent access through monitoring programs or otherwise to data on your Brand Technology, including sales figures. There are no contractual limitations on our right or timing to access this information and data.

Without limiting the generality of the foregoing, we reserve the right to require you to acquire, install and continuously use the Domino's PULSE store computer system and to obtain a license to use the software from us or our affiliate by signing our standard license agreement and to acquire hardware approved by us from a vendor or vendors which we designate. We also reserve the right to require you to participate in online ordering by entering into an agreement with an approved online ordering service company that we designate. You will be responsible for the fees and charges associated with your use of online ordering and the requisite internet usage and connections, including the fees charged by the service provider. We may also require that you continuously maintain high speed broadband connectivity, where available and to charge you a reasonable fee if you do not maintain high speed broadband connectivity, which you agree to pay on demand.

You acknowledge and agree that changes to technology are dynamic and not predictable within the term of this Agreement. In order to provide for inevitable but unpredictable changes to technological needs and opportunities, you agree that we shall have the right to establish, in writing, reasonable new standards for the implementation of technology in the Domino's System; and you agree to abide by and fully adopt and implement those reasonable new standards established by us as if this Section 15.9.1 were periodically revised by it for that purpose.

15.9.2 Aggregate Expenditures for Brand Technology.

You will not be required to make aggregate expenditures for any additions, substitutions, replacements or modifications to the Brand Technology in excess of one and one half percent (1 ½ %) of the royalty sales of the Store from the date of its opening to the date we require you to make any additions, substitutions, replacements or modifications to the Brand Technology not to exceed the ten (10) year period prior to the date we require you to make any additions, substitutions, replacements or modifications to the Brand Technology or, except in connection with a renewal of the franchise to make any additions, substitutions, replacements or modifications to the Brand Technology during the last twelve (12) months of the initial term of the franchise. This limitation shall not apply to our right to require that you acquire and install the Domino's PULSE store computer system or other components of the Brand Technology upon execution of this Agreement nor shall the provisions of any prior franchise agreement governing the operation of the Store restrict our right to require that you acquire and install the Domino's PULSE store computer system or other components of the Brand Technology under the terms of this Agreement.

15.9.3 Domino's PULSE and Other Computer and Technology Training.

If you (or the Controlling Person if you are an Approved Entity) have not installed and used Domino's PULSE, or any other computer system or technology that we require, in a Domino's Pizza store, you (or the Controlling Person) must enroll in and complete all training programs and classes which we require for the operation of Domino's PULSE, or any other computer system or technology. These training programs and classes will be furnished at such times and places as designated by us or the entity or entities that we approve to provide the training. We may furnish training. The entity furnishing the training (including us) has the right to charge a reasonable training fee for these training programs or classes, which you agree to pay. All training programs and classes must be completed to our satisfaction. You will be responsible for the travel, living expenses and any other costs incurred during these training programs and classes.

15.9.4 Additional Order Processing Systems.

We reserve the right to develop or contract with third parties to develop centralized or technology based methods of taking, processing, routing, and delivering orders in addition to the methods and technology we currently use or authorize (collectively "Additional Order Systems"). These may become mandatory at any time during the term of this Agreement and may require you to spend money to add or replace equipment, wiring, hardware and software; to pay licensing fees, support and maintenance fees, fees paid to third parties; to incur other costs, and to sign agreements with third parties. To the extent these products and services are owned by us or provided to you by us, we may charge up front and/or ongoing fees. However, to the extent all the direct and indirect costs to develop, test and implement an Additional Ordering System are paid from other sources, then such up-front and ongoing fees charged by us would be intended only to cover our ongoing expenses, including direct costs and reasonable allocations. Regardless of the sources of funds to develop any Additional Ordering System we shall be the sole owner of all direct and related rights and assets, including software and hardware, intellectual property and all data

generated by the Additional Ordering Systems, but excluding hardware or equipment you purchase directly for the purpose of gaining access to the Additional Ordering System.

16. MARKS.

16.1 Usage.

You acknowledge that we have the right to sublicense the Marks and that any goodwill relating to your use of the Marks will inure to our benefit and the benefit of our affiliates. You shall use the Marks in full compliance with rules prescribed from time to time by us. You agree not to engage in any conduct which, in our sole judgment, could disparage or impair the reputation of the Store or the Domino's System or the goodwill associated with the Marks. You understand and acknowledge that our right to regulate the use of the Marks, includes, without limitation, any use of the Marks in any form of electronic media such as web sites or web pages or as a domain name or electronic media identifier. Any unauthorized use of the Marks will constitute a breach of this Agreement and an infringement of our rights in and to the Marks. You will not use any Mark as part of any corporate name or with any prefix, suffix or other modifying words, terms, designs or symbols or in conjunction or association with any name or symbol used by you in connection with the operation of the Store, nor may you use any Mark in connection with the sale of any unauthorized product or service or in any other manner not explicitly authorized in writing by us. All provisions of this Agreement applicable to the Marks will apply to any additional proprietary trademarks and commercial symbols we hereafter authorize you to use.

16.2 Infringements.

You agree to immediately notify us of any infringement of or challenge to your or our use of any Mark or claim by any person of any rights in any Mark. You agree that you will not communicate with any person other than us and our counsel in connection with any such infringement, challenge or claim. We will have sole discretion to take such action as we deem appropriate and the right to exclusively control any litigation or Patent and Trademark Office or other proceeding arising out of any infringement, challenge or claim or otherwise relating to any Mark. You agree to execute any and all instruments and documents, render such assistance and do such acts and things as may, in the opinion of our counsel, be necessary or advisable to protect and maintain our interests in any such litigation or Patent and Trademark Office or other proceeding or to otherwise protect and maintain our interest in the Marks.

16.3 Indemnification.

We will indemnify you against and reimburse you for all damages for which you are held liable in any proceeding arising out of the use of any Mark in compliance with this Agreement. If it becomes advisable at any time in our sole discretion for you to modify or discontinue use of any Mark and/or use one or more additional or substitute Marks, you agree to do so and our sole obligation will be to reimburse you for your tangible costs of complying with this obligation.

17. INSPECTIONS.

We or our designee will have the right at any time during business hours and without prior notice to conduct reasonable inspections of the Store, its operations and its business records,

including but not limited to, information from the Store's computers, and records and documents relating to the ownership and control of the Approved Entity and any other entity that has an interest in the operation of the Store, wherever located and to take a physical inventory of the assets of the Store. You agree that we may conduct all or part of an inspection, either on-site or from a remote location. Inspections of the Store will be made at our expense, unless we are required to make any additional inspections in connection with your failure to comply with this Agreement. In such event, we will have the right to charge you for the costs of making all additional inspections in connection with your failure to comply, including without limitation the travel expenses, room and board and compensation of our or our designee's employees. You and your owners agree to fully comply and cooperate with any and all inspections, including, but not limited to, you, your owners and your employees treating our personnel in a professional manner.

18. TERMINATION AND EXPIRATION.

18.1 Termination By Franchisee.

If you are in compliance with this Agreement and we breach this Agreement and fail to cure any breach within thirty (30) days after written notice is delivered to us, you may terminate this Agreement and the franchise effective ten (10) days after delivery of notice to us. A termination of this Agreement and the franchise by you without complying with these requirements or for any reason other than our breach of this Agreement and our failure to cure the breach within thirty (30) days after receipt of written notice from you shall be deemed a termination by you without cause and not in accordance with the provisions of this Agreement.

18.2.1 Immediate Termination By DPF - Upon Written Notice.

We shall have the right to terminate this Agreement effective upon delivery of notice of termination to you, if:

- (a) you or any of your owners have made any material misrepresentation on any record or report required by us under this Agreement or on your application for the franchise, or in any other application submitted to us;
- (b) you do not open the Store within six (6) months from the date of this Agreement;
- (c) you or any of your owners is judged a bankrupt, becomes insolvent, makes an assignment for the benefit of creditors, is unable to pay his or her debts as they become due, or a petition under any bankruptcy law is filed against you or any of your owners or a receiver or other custodian is appointed for a substantial part of the assets of the Store;
- (d) you abandon or fail to continuously and actively operate the Store, or, without our prior written consent, permit any person other than a qualified employee designated by you, whose identity has been disclosed to us, to operate the Store in your absence;

(e) the lease for the Store or other instrument or agreement governing the occupancy of the premises of the Store is terminated or cancelled or you are unable to renew or extend the lease or you fail to maintain possession of the Store premises;

(f) you or any of your owners is convicted of a felony, or a crime which substantially impairs the goodwill associated with the Marks or you or any of your owners engages in any conduct which, in our judgment, adversely affects the reputation of the Store or the Domino's System or the goodwill associated with the Marks or involves dishonesty, fraud, deceit, illegal conduct misrepresentation or moral turpitude;

(g) you intentionally or negligently under-report the royalty sales of the Store for any period or periods;

(h) you or any of your owners violates any of the restrictions contained in Section 20 or 21 of this Agreement;

(i) you intentionally or on more than one occasion during the term of this Agreement, violate any Child Labor Laws in connection with your operation of the Store;

(j) an audit by us discloses an understatement of royalty sales and you fail to pay to us the applicable royalty fee and advertising contribution and interest due within ten (10) days after receipt of the final audit report;

(k) the interest of a deceased or permanently disabled person is not disposed of in accordance with the terms of this Agreement;

(l) you or any of your owners fail on three (3) or more occasions during any twelve (12) month period to comply with any one or more provisions of any franchise agreement for the Store (which includes not only this Agreement but also the franchise agreement in force immediately prior to this Agreement if this Agreement has been in effect for less than twelve (12) months) including without limitation, your obligation to submit when due, sales reports or financial statements, to pay when due the royalty fees, advertising contributions or other payments to us or our affiliates or subsidiaries or any other creditors or suppliers of the Store, whether or not such failure to comply is corrected after notice is delivered to you;

(m) any of your assets or items used in the operation of the Store are seized or you are otherwise denied the use of the property or access to the Store because of your failure to pay any taxing authority or any amount due a creditor of the Store, or because of any other act or omission of you or any of your owners; or, you fail to notify us of a tax levy or delinquency; or

(n) you fail to cease operating the Store, or fail to correct the conditions in the Store causing a present threat of imminent danger to public health or safety, after notice to you as provided in Section 18.2.3 of this Agreement.

(o) we have granted you permission to either repair, restore, reconstruct or relocate the Store, as provided in Section 7.2 of this Agreement, and you fail to complete the action we have permitted, within six (6) months after its closure; or

(p) you or your owners violates any of the anti-terrorism provisions contained in Section 15.2 of this Agreement.

18.2.2 Termination By DPF - After Opportunity to Cure.

We shall have the further right to terminate this Agreement effective upon delivery of notice to you, if:

(a) you fail to obtain or maintain insurance required by us and you do not correct this failure within forty-eight (48) hours after written notice is delivered to you; provided, however, that we shall not exercise our right to terminate this Agreement if you immediately cease operating the Store and obtain all such insurance within ten (10) days after written notice is delivered to you;

(b) you fail to comply with any provision of this Agreement or any specification, standard or operating procedure or rule prescribed by us which relates to the use of any Mark, safety and security, or the quality of pizza or other authorized food products or any beverage sold by you or the cleanliness and sanitation of the Store and you do not correct this failure within seven (7) calendar days after written notice is delivered to you;

(c) you or your affiliates fail to pay when due any amount owed to us, our affiliates or subsidiaries, or any creditor or supplier or any taxing authority for federal, state or local taxes (other than amounts being bona fide disputed through formal proceedings) and you or your affiliates do not correct such failure within ten (10) calendar days after written notice is delivered to you; or

(d) you or any of your owners fails to comply with any other provision of this Agreement or any specification, standard or operating procedure and fail to correct this failure within thirty (30) calendar days after written notice is delivered to you.

18.2.3 Immediate Cessation of Operations.

In the event that the conditions of the Store or operations at the Store, in our judgment, present a threat of imminent danger to public health or safety, we may require the immediate cessation of operations at the Store upon delivery of a notice to you or the Store. The notice shall contain the reason we believe immediate cessation of operations is required. The parties shall address the conditions and develop a plan to correct all deficiencies within seven (7) days of the delivery of the notice.

18.3 Obligations Upon Termination or Expiration.

Upon termination or expiration of this Agreement, you agree to:

(a) immediately return to us all copies of the Operating Manual and cease use of and deliver to us all Customer Lists (as hereinafter defined in Section 20.5);

(b) take such action as may be required to cancel all assumed name or equivalent registrations relating to the use of any Mark;

(c) notify the telephone company, postal service, and all listing agencies in writing of the termination or expiration of your right to use all telephone numbers, post office boxes, and all classified and other directory listings relating to the Store and to authorize in writing the transfer of these to us or our franchisee or designee. You acknowledge that we have the sole rights to and interest in all telephone numbers, post office boxes and directory listings relating to any Mark, and you authorize us to direct the telephone company, the postal service, and all listing agencies to transfer all telephone numbers, post office boxes, and directory listings to us, our franchisee or designee and if you fail or refuse to do so, the telephone company, postal service, and all listing agencies may accept our direction as evidence of our exclusive rights in the telephone numbers, post office boxes, and directory listings and our authority to direct the transfer. Upon execution of this Agreement or at any time thereafter, you agree to execute any written authorizations or pre approved authorizations in the form prescribed by us directing the telephone company, postal service, and any listing agencies to transfer all telephone numbers, post office boxes, and directory listings to us, our franchisees or designees upon the occurrence of any such termination or expiration;

(d) immediately pay all royalty fees, advertising contributions and other charges which are due and owing under this Agreement;

(e) immediately cease using the Marks and identifying yourself as a Domino's Pizza Store or as being associated with the Domino's System, including, without limitation, disabling and ceasing to permit the continued operation of any website relating to the Store or the Domino's System or which utilizes the Marks;

(f) if you retain possession of the Store premises, at your expense, make such reasonable modifications to the exterior and interior of the Store (including signage, menu boards, job aids, product photos and the like) as we require to eliminate its identification and appearance as a Domino's Pizza Non-Traditional Store, as applicable. If you fail or refuse to fully de-identify the Store to the extent and in the manner required by this Agreement, we may, at our option and in addition to other rights and remedies we may have, make the modifications that are contemplated by this Agreement on your behalf and you agree to promptly pay and reimburse us on demand for any costs incurred by us or our designee including, without limitation, the proportionate compensation of our or our

designee's employees who devote time and render services in the de-identification of the Store; and

(g) make the Store accessible and available for us to operate pursuant to Section 19.8 of this Agreement if we elect to do so.

19. OPTION TO PURCHASE STORE.

19.1 Option.

Upon the termination or expiration of this Agreement, except termination by you for cause, we or our designee shall have the exclusive option, but not the obligation, to purchase the assets of the Store. For purposes of this section, the term "assets" shall mean the equipment, inventory, leasehold interests and improvements and favorable rights and covenants of the Store. Our option shall commence upon expiration of this Agreement or on the effective date of termination as applicable and shall continue for thirty (30) days thereafter, subject to extension as provided in this Section. You agree that if the termination is stayed, either by us or by judicial proceedings, or if we are not permitted to manage the Store pursuant to section 19.8, we will not be able to exercise our option within the 30 day period and you also agree that under those circumstances our option to purchase shall be extended, without further notice to you, for an additional time which shall include the entire time we are unable to exercise our option.

19.2 Formula Price.

The purchase price for these assets shall be equal to fifteen percent (15%) of the first Three Hundred Thousand Dollars (\$300,000.00) of royalty sales ("Base Amount") of the Store during the fifty two (52) full weeks immediately preceding the date of termination or expiration plus twenty five percent (25%) of royalty sales in excess of the Base Amount up to Five Hundred Thousand Dollars (\$500,000.00) ("Second Level Base Amount") during this period plus fifty percent (50%) of royalty sales in excess of the Second Level Base Amount during this period. The purchase price shall be allocated among the assets and covenants in the manner prescribed by us.

If the Store has been in operation less than fifty two (52) full weeks, the option price shall be the documented cost of the Store. The term "cost" shall be defined as your documented expenditures for the equipment, inventory and leasehold improvements of the Store, but shall not include any charges for labor performed by you or your family members in connection with the development of the Store or any undocumented costs.

19.3 Purchase of Commissary.

In the event you operate a commissary in connection with the Store, we or our designee shall also have the option to purchase the assets of the commissary. The purchase price for the assets of the commissary will be the net book value (based upon a seven year depreciation schedule).

19.4 Deductions From Purchase Price.

In the event we elect to purchase the assets of the Store, the purchase price will be reduced by:

- (a) the total current and long term liabilities of the Store assumed by us as described below; and,
- (b) the amount necessary to upgrade and renovate the Store to meet our then current standards for a Domino's Pizza Non-Traditional Store; and
- (c) our reasonable attorney's fees incurred in connection with enforcing this Agreement or in securing possession of the Store.

We will assume all current and long term liabilities (except liabilities to you or your owners) up to the amount of the purchase price subject, however, to all defenses available to you. Further, the amount we charge for upgrading and renovating the Store will not exceed one and one half percent (1 1/2%) of the royalty sales of the Store from the date of opening to the date of termination or expiration reduced by an amount equal to the total expenditures made by you for renovation and upgrading of the Store at our request up to the date of termination or expiration.

19.5 Payment of Purchase Price.

The balance of the purchase price, after deductions described above will be payable as follows: ten percent (10%) of the balance at the time of closing and the remainder in sixty (60) equal monthly installments of principal plus interest at a rate of interest per annum equal to the prime lending rate charged by Morgan Guaranty Trust Company of New York (or other bank or financial institution we may designate) determined as of the closing date with annual adjustments based on the prime rate charged on each anniversary date. The first payment will be due on the first day of the second succeeding calendar month following closing and the remaining payments on the first day of each month thereafter. On the first payment date, interest from the date of closing shall also be paid. If we elect to pay the entire purchase price at closing, we shall have the right to escrow such portion of the purchase price as we deem appropriate for a period of six (6) months to cover liabilities of the Store. We shall notify you of claims asserted by creditors of the Store against the escrow monies. You shall have forty eight (48) hours to settle any claim with such creditor prior to our disbursement of funds from the escrow. If there is a good faith dispute between you and a creditor of the Store, you shall have thirty (30) days to reach a settlement with any such creditor as to the amount owed before we will disburse any escrow monies to such creditor. If you are unable to resolve the discrepancy with the creditor within the thirty (30) day period, we shall have the right to use the escrow monies to satisfy the claim of any such creditor. At the end of such six (6) month period, any remaining purchase price shall be remitted to you along with a statement prepared by DPF indicating the manner in which these funds were expended.

19.6 Real Property.

(a) In the event you or your owners own the real property on which the Store or commissary is located, and such property is not a multi-tenant unit, we will also have the exclusive option to purchase this property. We shall exercise this option within the same period of time as provided in section 19.1, as that time may be extended. The purchase price will be the fair market value as determined by an independent appraiser selected by both of us. If we cannot agree on an independent appraiser, we each shall select an independent appraiser who shall select a third independent appraiser. The independent appraiser selected by our appraisers shall determine the fair market value of the real property and his determination shall be final and binding on the parties, provided, in the event the independent appraiser does not render its appraisal within ninety (90) days of selection, the appraisal shall be made by the appraiser we have selected. The purchase price will be payable in full at the closing minus customary prorations including the pay-off of existing mortgage liens.

(b) If we do not elect to purchase the real property, or if the property is in a multi-tenant unit, we or our designee will have the option to enter into a lease for a term of not less than five (5) years with an option by the lessee to extend the term of the lease for an additional term of five (5) years. The lease shall contain the terms and conditions contained in the form of lease then used by us or our affiliates in connection with Domino's Pizza Stores owned and operated by us or our affiliates. The rental under the lease for the initial five (5) year term shall be the fair rental value of the property as determined by an independent appraiser selected in the manner described above. The rental shall be modified during the second five (5) year option term by the percentage that the National Consumer Price Index for Urban Wage Earnings and Clerical Workers as determined by the United States Department of Labor for the region in which the Store is located (or a comparable index if such Index is not then being issued) has increased or decreased from the commencement date of the initial term until the last day of the initial term of the lease.

19.7 Closing.

The closing shall occur within thirty (30) days after we exercise our option to purchase the assets and/or real property or such later date as may be necessary to comply with applicable bulk sales or similar laws. At the closing, we both agree to execute and deliver all documents necessary to vest title in the purchased assets and/or real property in us free and clear of all liens and encumbrances, except those assumed by us and/or to effectuate the lease of the Store premises. You also agree to provide us with all information necessary to close the transaction. We reserve the right to assign our option to purchase the Store or commissary, if any, operated in connection with the Store (and the real property to the extent applicable) or designate a substitute purchaser for the Store. We agree, however, to be responsible for and shall guarantee payment of any deferred portion of the purchase price as provided in Section 19.5 of this Agreement in the event we designate a substitute purchaser of the assets of the Store. If you do not execute and deliver any documents required, by execution of this Agreement you irrevocably appoint us as your lawful attorney in fact with full power and authority to execute and deliver in your name all these documents. You also agree to ratify and confirm all of our acts as your lawful attorney in fact and to indemnify and hold us harmless from all claims, liabilities, losses or damages suffered by us in so doing.

19.8 Operation During Option Period.

We will have the right, upon written notice to you, to manage, or designate one of our affiliates to manage, the Store during the period in which we have the option to purchase the Store as provided in section 19.1 and for the period following the exercise of our option and prior to the closing, on the same terms and conditions as described in Section 21.7.

19.9 Formula Price.

The parties agree that the formula price described in this Section 19 is the agreed upon method of arriving at a price for the assets of the Store in the event we exercise the option contained in this Section 19 and is not to be deemed a conclusive indication of the value of the Store under other circumstances or where an agreement to purchase the Store has been negotiated by you or your owners.

20. RESTRICTIVE COVENANTS.

20.1 In Term Covenant.

In addition to all other obligations in the Agreement, you agree that, during the term of this Agreement, you or your owners will not, directly or indirectly for the benefit of you or your owners, or through or on behalf of or in conjunction with any other person, partnership or corporation, own, engage in, be employed by, advise, assist, invest in, franchise, make loans to, or have any other interest, whether financial or otherwise, in any other carry out or delivery pizza store business or business similar to that being conducted pursuant to this Agreement (except for other Domino's Pizza Stores or Domino's Pizza Non-Traditional Stores operated under franchise agreements entered into with us or other Domino's Pizza Stores or Domino's Pizza Non-Traditional Stores in which you or your owners have an ownership interest).

20.2 Post Term Covenant.

You agree that, for a period of one (1) year after termination or expiration of this Agreement, or the date on which you cease to operate the Store, whichever is later, you or your owners will not, directly or indirectly for the benefit of you or your owners, or through or on behalf of or in conjunction with any other person, partnership or corporation, own, engage in, be employed by, advise, assist, invest in, franchise, make loans to, or have any other interest, whether financial or otherwise, in any carry out or delivery pizza store business or business similar to that being conducted pursuant to this Agreement located at the premises of the Store or within ten (10) miles of the premises of the Store (except for other Domino's Pizza Stores or Domino's Pizza Non-Traditional Stores operated under franchise agreements with us or other Domino's Pizza Stores or Domino's Pizza Non-Traditional Stores in which you or your owners shall have an ownership interest). The covenant contained in this section shall not be deemed to impair, modify or change any covenant not to compete contained in any agreement for the purchase and sale of the Store and shall be in addition to all other obligations you have under this Agreement to us or our affiliates upon termination or expiration of this Agreement.

20.3 Ownership of Public Companies.

The covenants contained in this Section 20 shall not apply to ownership of less than a five percent (5%) beneficial interest in the outstanding equity securities of any corporation whose stock is publicly traded.

20.4 Customer Lists and Trade Secrets.

You agree to maintain the absolute confidentiality of the Operating Manual and all other information concerning the Domino's System, whether provided by us or a third party, during and after the term of the franchise, disclosing this information to the other employees of the Store only to the extent necessary for the operation of the Store in accordance with this Agreement, and that you will not use the Operating Manual or such other information in any other businesses or in any manner not specifically authorized or approved by us in writing. The customer lists and all historical data relating to the sale of all pizza and beverage products at the Store (the "Customer Lists") also shall be deemed confidential and (a) you shall not use the Customer Lists in any other business or capacity; and (b) you shall maintain the absolute secrecy and confidentiality of the Customer Lists.

20.5 Owners of Approved Entity.

If you are an Approved Entity, the owners, by executing this Agreement, shall be bound by the provisions contained in this Agreement, including the restrictions set forth in this Section 20. Further, a violation of any of the provisions of this Agreement, including the covenants contained in this Section 20, by any owner shall also constitute a violation by you of your obligations under this Agreement.

20.6 Distribution of Products Related to the Domino's System.

During and after the term of this Agreement, you and your owners agree not to sell or otherwise distribute any products, or items bearing any of the Marks or which are used at any time in connection with any advertising, promotional or operational program other than to customers of your Store in the ordinary course of business or to another Domino's Pizza franchisee in good standing at the time of any proposed transfer approved by us.

20.7 Ownership Structure.

You, your owners and affiliates agree to fully comply with all rules, policies and procedures from time to time prescribed by us relating to the ownership structure of an Approved Entity. If you are an Approved Entity, you agree that the Controlling Person who has been approved by us will at all times during the term of this Agreement own and control fifty-one percent (51%) or more of the absolute voting and ownership interests of the Approved Entity, unless the Controlling Person obtains our prior written approval for a different ownership structure. You also agree to submit to us for our review and prior written approval any proposed change before attempting any change in the ownership or control of the Approved Entity or its affiliates, or any documents governing the ownership or control of the Approved Entity or its affiliates.

20.8 Non-Disclosure.

Except as may be required or permitted by applicable law, you agree that neither you nor your affiliates, owners, representatives, agents or employees will make any statements or communications, directly or indirectly, about us or our affiliates, officers, employees, franchisees (including you or your affiliates), businesses, properties, financial condition, sales trends, management, ownership, past or current business practices or strategies to any person, including, without limitation, the media or any financial analysts, whether verbally or in writing, including, without limitation, any communications or statements that would reasonably be expected to adversely affect our business or reputation or the Domino's System or shareholders of Domino's Pizza, Inc. or its affiliated companies.

20.9 Irreparable Injury and Injunctive Relief.

You acknowledge and agree that the provisions of this Section 20, including, without limitation, the provisions of Sections 20.1, 20.2, 20.5 and 20.9, are necessary to protect our legitimate business interests and the Domino's System, to prevent the unauthorized dissemination of marketing, promotional and other confidential information to our competitors and others outside of the Domino's System, to protect our trade secrets and the integrity of the Domino's System, and to prevent the duplication of the Domino's System. You also acknowledge and agree that damages alone cannot adequately compensate us if there is a violation of these provisions by you or your owners, that we will suffer irreparable harm arising out of any such violation, and that injunctive relief against you and your owners is essential for the protection of us and our franchisees. Accordingly, we will have the right to petition a court of competent jurisdiction for injunctive relief against you and your owners without posting any bond or security whatsoever, in addition to all other remedies that may be available to us under this Agreement or applicable law.

21. ASSIGNMENT.

21.1 By DPF.

This Agreement is fully assignable by us and the assignee or other legal successor to our interests will be entitled to all of the benefits of this Agreement.

21.2 By Franchisee.

This Agreement is personal to you and your owners (if you are an Approved Entity). Accordingly, neither you nor any of your owners may assign or transfer this Agreement, any interest in this Agreement or, if you are an Approved Entity, any interest in an Approved Entity except as specifically authorized under this Agreement. A transfer of ownership of the Store (or its assets) may only be made in conjunction with a transfer of this Agreement. Any attempted assignment or transfer not in accordance with this Agreement shall have no effect and shall constitute a breach of this Agreement.

21.3 Assignment to an Approved Entity.

We will allow you to assign this Agreement and the Store (and its assets) to an Approved Entity for the convenience of ownership of the Store, provided:

- (a) the Approved Entity conducts no business other than the operation of the Store or other Domino's Pizza Stores (or other related activities authorized under this Agreement);
- (b) the Approved Entity is actively managed by you;
- (c) the person designated as the Controlling Person owns and controls not less than fifty-one percent (51%) of the general partnership interest of such partnership, the equity and voting power of all classes of issued and outstanding capital stock of such corporation, the membership interest in the limited liability company or the voting and ownership interests of such entity; and
- (d) all owners meet our requirements as established from time to time by us and agree to guarantee the obligations of the Approved Entity under this Agreement and to be bound by the terms of this Agreement in the manner prescribed by us.

If you are an Approved Entity or if this Agreement is assigned to an Approved Entity, you must comply with the requirements set forth in this Section 21.3 throughout the term of this Agreement. The organization documents of any Approved Entity owning the franchise, including all stock certificates, shall recite that they are subject to all restrictions contained in this Agreement. We shall also have the right to require, as a condition of any assignment of this Agreement to an Approved Entity or the operation of the franchise by an Approved Entity, that the owners enter into a buy/sell agreement among themselves in a form and containing such terms as we prescribe for transfers of ownership interests in such Approved Entity. You shall provide us with all documents to be executed in connection with any such assignment and we shall use our reasonable efforts to approve or disapprove these within thirty (30) days after receipt.

21.4 Assignment or Transfer to Others.

We will permit sales, transfers or assignments of this Agreement or, if you are an Approved Entity, of an ownership interest in the Approved Entity to others provided:

- (a) you (and your owners) are not in default under this Agreement or any other agreement with us or our subsidiaries or affiliates or any other creditor or supplier of the Store;
- (b) the proposed transferee or assignee (and its Controlling Person and all other owners if it is an Approved Entity) meets our then-applicable standards for franchisees or owners;

(c) the proposed transferee or assignee (and its owners) is not engaged in any other business activity without our prior written consent, except other Domino's Pizza Stores;

(d) the proposed transferee or assignee (and its owners if it is an Approved Entity) must sign our then-current form of standard franchise agreement for a term equal to the remaining term of this Agreement or, at our election, the then-current term if longer;

(e) the proposed transferee or assignee (or the person designated by us) must complete all required training to the extent required by us;

(f) at our request, the proposed transferee or assignee refurbishes the Store in the manner and subject to the provisions prescribed in Sections 9 and 15;

(g) the proposed transferee or assignee pays us a transfer fee of \$1,500.00; and

(h) this Agreement is terminated according to the terms of our customary form of mutual termination agreement and customary form of release.

The provisions of (d), (e), (f), (g), and (h) above shall not apply to an approved sale, transfer or assignment by an owner owning a forty-nine percent (49%) or less interest in the Approved Entity except that the proposed transferee or assignee must guarantee the performance by Franchisee of its obligations under this Agreement and agree to be bound by all of the provisions of this Agreement in the form prescribed by us. You must provide us with all documents to be executed by you and/or your owners and the proposed purchasers in connection with any transfer or assignment at least thirty (30) days prior to signing.

21.5 Death or Permanent Disability.

Upon your death or permanent disability or the death or permanent disability of the Controlling Person, this Agreement or the ownership interest of such deceased or permanently disabled Controlling Person must be transferred to a party approved by us. Any transfer, including, without limitation, transfers by devise or inheritance or trust provisions, shall be subject to the same conditions for transfers which are contained in this Agreement. Except as otherwise prescribed by us in writing, your personal representative or the personal representative of such Controlling Person shall submit to us a proposal meeting the requirements for transfer of this Agreement or such ownership interest within one hundred and twenty days (120) days of your death or permanent disability or the death or permanent disability of such Controlling Person. We agree to communicate our approval or disapproval of any such proposal within fifteen (15) days of receipt. We will not unreasonably withhold our consent to the transfer of this Agreement or such ownership interest to your spouse, heirs or relatives or the spouse, heirs or relatives of such deceased or permanently disabled Controlling Person, provided the requirements of Section 21.4 are satisfied. Your personal representative or the personal representative of such deceased or permanently disabled Controlling Person shall complete the transfer of this Agreement or such ownership interest within sixty (60) days from the date of our approval of any such proposal. Upon the death of any other owner, the interest of such owner shall be transferred within a reasonable

time to a person meeting our requirements. All such transfers must also comply with Section 21.4 of this Agreement. Your or any of your owners' failure to transfer the interest in accordance with the provisions of this Section shall be considered a breach of this Agreement.

21.6 Definition of Permanent Disability.

You or your Controlling Person, will be deemed to have a "permanent disability" if you or your Controlling Person's usual, active participation in the Store as contemplated by this Agreement is for any reason curtailed for a continuous period of six (6) months.

21.7 Operation by DPF After Death or Permanent Disability.

We shall have the right to appoint a manager for the Store if in our judgment the Store is not being managed properly after your death or permanent disability or the death or permanent disability of the Controlling Person. Our right to appoint a manager for the Store includes the right to temporarily or permanently cease operations at the Store, if in our reasonable judgment continued operation of the Store will adversely affect the Marks, the long term reputation of the Store or the Domino's System, or present a risk to public health, welfare and safety, including the well-being of the employees of the Store. All funds from the operation of the Store during the management by our appointed manager will be kept in a separate fund, and all expenses of the Store including compensation, other costs, and travel and living expenses of our manager will be charged to this fund. We will charge a management fee of five and one-half percent (5 1/2%) (in addition to the royalty fee and advertising contributions payable under this Agreement) during the period in which the Store is managed on your behalf. In managing the Store, our obligation will be to use our reasonable efforts to ensure the Store is properly managed, and neither we nor our affiliates will be liable for any debts, losses or obligations of the Store, to any of your creditors for any products, materials, supplies or services purchased by the Store prior to or during the time of management by our appointed manager. If the separate fund that is established is insufficient to pay the expenses of the Store, we will notify you or your executor, administrator, conservator or other personal representative and this person must deposit in the fund within five (5) business days, any amount required by us to attain a reasonable balance in the fund.

21.8 Right of First Refusal of DPF.

If you or your owners propose to sell or transfer all or any part of the Store (or its assets) or, if you are an Approved Entity, any ownership interest in an Approved Entity and you or your owners obtain a bona fide, executed written offer to purchase or otherwise transfer or acquire this interest, you or your owners are obligated to deliver a copy of the bona fide offer to us along with all documents to be executed by you or your owners and the proposed assignee or transferee. Our right of first refusal shall commence upon the date of our receipt of the following: (i) the bona fide, executed written offer to purchase, transfer or acquire; (ii) all documents to be executed by you or your owners and the proposed assignee or transferee; (iii) all documents related to the operation of the Store which you are required to provide us, including, but not limited to a current copy of the lease for the Store and such financial statements as are required of you under Section 14.2 of this Agreement; and (iv) your notice that you are specifically submitting the documents to give us the right to exercise our right of first refusal, and shall continue for a period of thirty (30) days thereafter. Failure to submit any one or more of the items, including the notice of the purpose of

the submission, shall result in our right of first refusal being extended until 30 days after we receive all of the required documents and the notice. We shall exercise the right to purchase or otherwise acquire the Store (or its assets) or such ownership interest for the price and on the terms and conditions contained in the offer by giving written notice to you or your owners. We may substitute equivalent cash for any form of payment proposed in such offer or designate a substitute purchaser or transferee for the Store (or the assets) or the ownership interest being offered, provided that we will assume responsibility for the performance of any other purchaser we may designate. If the offer is to purchase the interest of a Controlling Person and is for less than all of the outstanding interests of the Approved Entity, we shall also have the right, during the same period of time described above and upon written notice to the other owners, to purchase or otherwise acquire the remaining shares of capital stock, partnership interest or membership interest at a per share or per unit or interest price (or other terms) equivalent to the price (or other terms) being offered under the bona fide offer to the Controlling Person. If we do not exercise this right of first refusal, the offer may be accepted by you or your owners, subject to our prior written approval as provided in this Agreement. If the offer is not accepted by you or your owners, within sixty (60) days, we will again have the right of first refusal to purchase or otherwise acquire the Store as described above. This section will not apply to transfers made in accordance with Section 21.3 of this Agreement.

22. CONTRACT INTERPRETATION AND ENFORCEMENT.

22.1 Effect of Waivers.

No waiver by us of any breach or a series of breaches of this Agreement shall constitute a waiver of any subsequent breach or waiver of the performance of any of your obligations under this Agreement. Our acceptance of any payment from you or the failure, refusal or neglect by us or you to exercise any right under this Agreement or to insist upon full compliance with our or your obligations under this Agreement or with any specification, standard or operating procedure or rule will not constitute a waiver of any provision of this Agreement.

22.2 Cost of Enforcement.

If any legal or equitable action is commenced, either to challenge, interpret, or to secure or protect our rights under or to enforce the terms of this Agreement, in addition to any judgment entered in our favor, we shall be entitled to recover such reasonable attorney's fees as we or anyone acting on our behalf may have incurred together with court costs and expenses of litigation.

22.3 Indemnification of DPF.

If we or any of our subsidiary or affiliated companies or any of our or their agents or employees are required to produce records or testify at trial or in deposition or are subjected to any claim, demand or penalty or become a party to any suit or other judicial or administrative proceeding brought by any person or persons (including your employee or prior employee) or any other person or entity by reason of any claimed act or omission by you, your employees or agents, or by reason of any act or omission occurring on the Store premises, or in your delivery service area, or while on the way to or from the delivery service area, by reason of an act or omission with respect to the business or operation of the Store, including but not limited to acts or omissions

arising out of the maintenance or use of a motor vehicle or while making a delivery or returning from making a delivery, or any limitations on delivery service, you shall defend and indemnify and hold us, our subsidiary and affiliated companies, or any of our or their agents or employees, harmless against all judgments, settlements, penalties, and expenses, including attorney's fees, court costs and other expenses of litigation or administrative proceeding, incurred by or imposed on us, our subsidiary and affiliated companies, or any of our or their agents or employees, in connection with the testimony, production, investigation or defense relating to such claim or litigation or administrative proceeding. Your indemnification obligations described above will continue in full force and effect after, and notwithstanding, the expiration or termination of this Agreement.

22.4 Construction and Severability.

Section headings are for convenience only and shall not limit the enforceability or obligations contained therein. All references in this Agreement to the singular shall include the plural where applicable, and all references to the masculine shall include the feminine and vice-versa. If any part of this Agreement for any reason shall be declared invalid, such decision shall not affect the validity of any remaining portion, which shall remain in full force and effect. If any applicable law or rule requires a greater prior notice of the termination of or election not to renew this Agreement, or the taking of some other action than is required under this Agreement, the prior notice or other requirements required by this law or rule shall be substituted for the requirements of this Agreement. If any covenant in this Agreement which restricts competitive activity is deemed unenforceable by virtue of its scope in terms of area, business activity, prohibited and/or length of time, but would be enforceable by reducing any part or all thereof, the parties agree that same shall be enforced to the fullest extent permissible under the laws and public policies applied in the jurisdiction in which enforcement is sought. For purposes of this Agreement, the term "affiliate or affiliates" shall mean any entity or entities controlled by, controlling, or under common control or common ownership with Franchisee (or any of its Owners) or DPF, as the case may be.

The rights and remedies of each party under this Agreement are cumulative, and no exercise or enforcement by a party of any right or remedy hereunder will preclude the exercise or enforcement of any other right or remedy hereunder.

22.5 Scope and Modification of Agreement.

This Agreement constitutes the entire agreement between the parties and supersedes all prior and contemporaneous, oral or written, agreements or understandings of the parties regarding the subject matter of this Agreement, provided that nothing in this Agreement or in any related agreement is intended to disclaim the representations we made in any franchise disclosure document we delivered to you in connection with this Agreement. Further, nothing in this Agreement or in any related agreement is intended to prevent or restrict you from contacting or communicating with any federal, state or local authorities or agencies about our compliance with any applicable laws, including franchise laws, or the relationship of the parties under this Agreement or any related agreement. No modification, waiver, termination, rescission, discharge or cancellation of this Agreement shall affect the right of any party to enforce any claim or right

under this Agreement, whether or not liquidated, which occurred prior to the date of such modification, waiver, termination, rescission, discharge or cancellation.

22.6 Governing Law.

The terms and provisions of this Agreement shall be interpreted in accordance with and governed by the laws of the State in which the Store is located.

22.7 Notices.

All written notices permitted or required to be delivered by the provisions of this Agreement or of the Operating Manual shall be deemed so delivered when delivered to you or the Store by: (i) hand delivery; (ii) three (3) days after having been placed in the United States Mail by Registered or Certified Mail; (iii) one (1) day after being placed in the hands of a commercial courier service for next day delivery; or (iv) one (1) day after transmission by facsimile or other electronic system (including via e-mail and including e-mails which you are the only addressee or one of multiple addressees). Notices delivered pursuant to this section including, without limitation, e-mail, shall be addressed to us at our most current principal business address or to you at the most current principal business address, e-mail address or home address of which we have been notified in writing. You are obligated to provide us with a correct current address for your home and business and to notify us of any change in address within ten (10) business days. If you maintain an e-mail address for your business you agree to provide us with your business e-mail address and notify us of any change in your e-mail address within ten (10) business days. You understand and agree that providing us with notice of changes in addresses (including e-mail address) shall be made in the manner provided in this section for giving notices. If you fail to timely notify us of a change of address (including e-mail, business or home), all notices sent to the prior address will be deemed properly delivered.

22.8 Independent Contractors.

The parties to this Agreement are independent contractors and no training, assistance or supervision which we may give or offer to you shall be deemed to negate such independence or create a legal duty on our part. Neither we nor any of our affiliates shall be liable for any damages to any person or property arising directly or indirectly out of the operation of the Store, including but not limited to those damages which may occur while your employees are making or returning from making deliveries, or arising out of your delivery service policies. Nor shall we or any of our affiliates have any liability for any taxes levied upon you, your business, or the Store. The parties further acknowledge and agree the relationship created by this Agreement and the relationship between us is not a fiduciary relationship nor one of principal and agent. Furthermore, neither we nor our affiliates have any relationship with your employees and have no rights, duties, or responsibilities with regard to their employment by you. You acknowledge and agree that you do not have the authority to act for or on our behalf or to contractually bind us or our affiliates to any agreement. No party to this Agreement shall have any authority to assume any liability for the acts of the other, or to alter the legal relationships of the other. Only the named parties to this Agreement shall have rights hereunder and you shall not have any rights under any other franchise agreement to which you are not a party.

22.9 Standard of Reasonableness.

Unless otherwise stated in this Agreement, we agree to exercise reasonable judgment with respect to all determinations to be made by us under the terms of this Agreement.

22.10 Acknowledgments.

(a) The following acknowledgments are made by and binding upon all franchisees signing this Agreement, except those franchisees and franchises that are subject to the state franchise registration/disclosure laws in California, Hawaii, Illinois, Indiana, Maryland, Michigan, Minnesota, New York, North Dakota, Rhode Island, South Dakota, Virginia, Washington, or Wisconsin:

(i) You acknowledge that you have read this Agreement and our Franchise Disclosure Document and been given an opportunity to obtain clarification of any provision that you did not understand.

(ii) You acknowledge that you have conducted an independent investigation of the business contemplated by this Agreement and recognize that it involves business risks making the success of the venture largely dependent upon your business abilities.

(iii) We expressly disclaim the making of, and you acknowledge that you have not received or relied upon, any warranty or guarantee, express or implied, as to the potential volume, profits or success of the business venture contemplated by this Agreement.

(b) You acknowledge that you have conducted an independent investigation of the Store's delivery and service area and are familiar with the boundaries and the nature and extent of any areas that might present a danger to you or your employees. In addition, you acknowledge and agree that this Agreement may not be modified, amended or changed except by a writing signed by all parties. You also acknowledge that this Agreement has been executed by us in the State of Michigan and that this Agreement is to be performed in part through services rendered in the State of Michigan.

22.11 Binding Effect.

This Agreement is binding upon the parties and their heirs, approved assigns and successors in interest.

22.12 No Waiver or Disclaimer of Reliance in Certain States.

The following provision applies only to franchisees and franchises that are subject to the state franchise registration/disclosure laws in California, Hawaii, Illinois, Indiana, Maryland, Michigan, Minnesota, New York, North Dakota, Rhode Island, South Dakota, Virginia, Washington, or Wisconsin:

No statement, questionnaire, or acknowledgement signed or agreed to by you in connection with the commencement of the franchise relationship shall have the

effect of (i) waiving any claims under any applicable state franchise law, including fraud in the inducement, or (ii) disclaiming reliance on any statement made by DPF, any franchise seller, or any other person acting on behalf of DPF. This provision supersedes any other term of any document executed in connection with the franchise.

22.13 Effective Date of this Agreement.

This Agreement shall become effective upon the date of its acceptance and execution by us.

DOMINO'S PIZZA FRANCHISING LLC

FRANCHISEE:

By: _____
Colleen McCormick

By: _____

Its: Sr. Manager – Regulatory Affairs and
Contracts

Its:

DATED: _____

DATED: _____

DATE OF STORE OPENING

[THIS PAGE INTENTIONALLY LEFT BLANK]

COVENANTS OF OWNERS

The undersigned individuals (the "Owners") represent and warrant to DPF that they are all of the owners of Franchisee or otherwise have a direct or indirect interest in the success of Franchisee and that the person designated below as the Controlling Person is the Controlling Person of the Approved Entity under this Agreement. Further, to induce DPF to enter into this Agreement and grant the franchise to Franchisee, each of the Owners, on behalf of themselves and each of their affiliates, hereby jointly and severally guarantees the performance by Franchisee of its obligations under this Agreement and agrees to be bound by all of the provisions of this Agreement, including, without limitation, the restrictions contained in Sections 20 and 21 of this Agreement, provided that the liability of the Owners and their affiliates to DPF under their guarantee, other than the Controlling Person and his or her affiliates, shall be based upon the percentage of such Owner's ownership interest in Franchisee.

Each Owner acknowledges and agrees that:

(1) The Approved Entity shall be managed solely by the Controlling Person and that the Controlling Person may not be removed by any action of the Approved Entity or its Owners without the prior written consent of DPF;

(2) The Controlling Person shall at all times during the continuation of this Agreement have not less than fifty one percent (51%) of the equity and voting power and/or interests in the Approved Entity unless otherwise approved in writing by DPF and any provision or term in the governing or establishing documents for the Approved Entity or any agreement between the Owners to the contrary is and shall be void for all purposes;

(3) The establishing or governing documents for the Approved Entity do not provide for a "supermajority" or other voting structure that would require the Controlling Person to have more than 51% of the equity and voting structure in order to maintain control over the Approved Entity and that no Owner(s) has any type of "veto" rights and that no voting trusts have been established which would restrict or limit the voting control of the Controlling Person. If such provision or term exists in the establishing or governing documents or other agreements, the Owners agree that it shall be void for all purposes;

(4) The Controlling Person has, as of the date of execution of this Agreement, the option, but not the obligation, exercisable on thirty (30) days notice, to purchase any or all of the equity and voting interest owned by the other Owners for a sum certain which has been determined prior to the execution of this Covenant of Owners (which may be modified by the Owners). If for any reason all Owners have not agreed upon a purchase price, the undersigned Owner(s) agree that the purchase price for their interest shall be the fair market value for all of the Domino's Pizza Stores, Domino's Pizza Non-Traditional and Domino's Pizza Transitional Stores which the Approved Entity operates as determined by an independent appraiser selected by the Controlling Person and the Owners holding a majority of the remaining interests. If the Controlling Person and the Owners holding a majority of the remaining interests cannot agree on an independent appraiser, the Controlling Person shall select an independent appraiser and the

Owners holding a majority of the remaining interests shall select an independent appraiser and those two (2) appraisers shall select a third independent appraiser. The third independent appraiser selected by the two (2) appraisers shall determine the fair market value of the equity and voting interest owned by the Owners and the determination of the third independent appraiser shall be final and binding on all parties. If an independent appraiser is not selected through this process within sixty (60) days, DPF shall have the right to select an independent appraiser whose determination of the fair market value shall be binding and final on all parties and DPF shall incur no liability for doing so. The result of such computation shall be multiplied by the ratio that the Owner's interest bears to all outstanding ownership interests in the Approved Entity. Upon tendering the purchase price for each Owner's interest, the Owners hereby agree to convey such interest and such commitment shall be subject to enforcement by any court of competent jurisdiction through specific performance;

(5) If the Controlling Person receives a bona-fide offer and desires to sell the franchise, the Franchisee can require the other Owners to sell his/her interest in accordance with the terms of the bona-fide offer.

(6) None of the Owners has given, received or taken any security interest in this Agreement or any pledge of any equity or interest in the Approved Entity and no such security interest or pledge shall be given, received or taken during the continuation of this Agreement;

Each Owner also acknowledges and agrees, on behalf of such Owner and each of their affiliates, that DPF may apply any monies DPF may owe to any Owner or any of his/her affiliates, including, without limitation, from any profit sharing arrangements, to satisfy or offset amounts owed by Franchisee or any Owner or their affiliates to us or our affiliates under the Franchise Agreement or any other agreement. Each Owner also acknowledges and agrees, on behalf of himself/herself and each of their affiliates, that DPF shall have recourse against and be entitled to pursue the assets of any other Domino's Pizza store owned by such owner and his or her affiliates to recover or satisfy any amounts owed by Franchisee or any Owner or their affiliates to us or our affiliates under the Franchise Agreement or any other agreement.

These Covenants of Owners are intended to modify and supersede any provisions of the establishing or governing documents for the Approved Entity or other agreement between the Owners which are inconsistent with its terms. In the event of any inconsistency between these Covenants of Owners and any other agreement or governing or establishing document, these Covenants of Owners shall control. The undersigned acknowledge that the execution of these Covenants of Owners are conditions to approval by DPF of assignment or entry of this Agreement with DPF, and DPF shall be entitled to refuse to acknowledge or recognize any provisions of the governing or establishing documents of the Approved Entity which are inconsistent with the terms of these Covenants of Owners or this Agreement. Each of the Owner(s) agree that in the event that any of the governing or establishing documents for the Approved Entity are inconsistent with the provisions of these Covenants of Owners, the Controlling Person is granted the authority and power to modify or amend such provision and each Owner agrees to cast any necessary vote in favor of the amendment of such document or to execute such agreement as will reconcile these Covenants of Owners and the applicable document or agreement. The undersigned further agree

that the governing and establishing documents of the Approved Entity shall not be amended, modified, deleted, novated or otherwise changed in any manner without the prior written consent of DPF.

CONTROLLING PERSON

% of Ownership

OWNER: N/A

% of Ownership N/A

OWNER: N/A

% of Ownership N/A

OWNER: N/A

% of Ownership N/A

**RIDER (FOR RESIDENTS OF ILLINOIS)
TO THE DOMINO'S PIZZA FRANCHISING LLC
NON-TRADITIONAL STORE FRANCHISE AGREEMENT
BETWEEN DOMINO'S PIZZA FRANCHISING LLC AND**

DATED _____, _____

1. Section 22, Paragraph 22.6 of the Non-Traditional Store Franchise Agreement is hereby amended to read as follows:

22.6 **Governing Law.** The terms and provisions of this Agreement shall be interpreted in accordance with and governed by the laws of the State in which the Store is located or by the laws of the State in which you reside. However, if the jurisdictional requirements of the Illinois Franchise Disclosure Act are met independently without reference to this Paragraph; then this Agreement (and its validity, interpretation and construction), any claims arising from this Agreement, and the relationship between us and you will be governed by the laws of the State of Illinois.

DOMINO'S PIZZA FRANCHISING LLC

FRANCHISEE

By: _____
Colleen McCormick

By: _____

Its: Sr. Manager – Regulatory Affairs
and Contracts

**RIDER (FOR RESIDENTS OF MARYLAND) TO THE DOMINO'S PIZZA
FRANCHISING LLC
NON-TRADITIONAL STORE FRANCHISE AGREEMENT**

This Rider is made and entered into as of _____ (this "**Agreement**") by and between _____, a _____ ("**Franchisee**") and **DOMINO'S PIZZA FRANCHISING LLC**, a Delaware limited liability company ("**Domino's**").

1. **BACKGROUND.** Domino's and Franchisee are parties to that certain Non-Traditional Store Franchise Agreement dated _____ that has been signed concurrently with the signing of this Rider. This Rider is annexed to and forms part of the Non-Traditional Store Franchise Agreement. This Rider is being signed because (a) Franchisee is a resident of Maryland, or (b) the Domino's Pizza Store will be located or operated in Maryland.

2. **RELEASES.** The following language is added to the end of the first sentence of Sections 3.1(c) and the end of Section 21.4(h) of the Non-Traditional Store Franchise Agreement:

; provided, however, that such general release shall not apply to any liability under the Maryland Franchise Registration and Disclosure Law.

3. **ACKNOWLEDGMENTS.** The following language is added to the end of Section 22.10 of the Non-Traditional Store Franchise Agreement:

Such representations are not intended to nor shall they act as a release, estoppel or waiver of any liability incurred under the Maryland Franchise Registration and Disclosure Law.

IN WITNESS WHEREOF, the parties have signed this Rider as of the dates set forth by their signatures, to be effective as of the Effective Date.

DOMINO'S PIZZA FRANCHISING LLC

FRANCHISEE:

By: _____

By: _____

Its: _____

Its: _____

DATED: _____

DATED: _____

**RIDER (FOR RESIDENTS OF MINNESOTA)
TO THE DOMINO'S PIZZA FRANCHISING LLC
NON-TRADITIONAL STORE FRANCHISE AGREEMENT
BETWEEN DOMINO'S PIZZA FRANCHISING LLC AND**

DATED _____, _____

1. The following language is hereby added to Section 22, Paragraph 22.4 of the Non-Traditional Store Franchise Agreement:

"Minnesota law provides franchisees with certain termination and non-renewal rights. Minn. Stat. Sec. 80C.14, Subd. 3, 4 and 5 require, except in certain specified cases, that a franchisee be given ninety (90) days notice of termination (with sixty (60) days to cure) and one hundred eighty (180) days notice for non-renewal of the Agreement."

DOMINO'S PIZZA FRANCHISING LLC

FRANCHISEE

By: _____
Colleen McCormick

By: _____

Its: Sr. Manager – Regulatory Affairs
and Contracts

**RIDER (FOR RESIDENTS OF NORTH DAKOTA)
TO THE DOMINO'S PIZZA FRANCHISING LLC
NON-TRADITIONAL STORE FRANCHISE AGREEMENT
BETWEEN DOMINO'S PIZZA FRANCHISING LLC AND**

DATED _____, _____

1. The following language is hereby added to Section 20, Paragraph 20.2 of the Non-Traditional Store Franchise Agreement:

"Covenants not to compete upon termination or expiration of the Franchise Agreement are generally unenforceable in the State of North Dakota."

2. Section 22, Paragraph 22.2 of the Non-Traditional Store Franchise Agreement, entitled Cost of Enforcement, is hereby amended to read as follows:

"22.2 **Cost of Enforcement**. The prevailing party in any enforcement action shall be entitled to recover all costs and expenses, including attorneys' fees."

DOMINO'S PIZZA FRANCHISING LLC

FRANCHISEE

By: _____
Colleen McCormick

By: _____

Its: Sr. Manager – Regulatory Affairs

and Contracts

WASHINGTON NON-TRADITIONAL STORE FRANCHISE AGREEMENT ADDENDUM

The following language is added to the end of the Non-Traditional Store Franchise Agreement:

In the event of a conflict of laws, the provisions of the Washington Franchise Investment Protection Act, Chapter 19.100 RCW will prevail.

RCW 19.100.180 may supersede the franchise agreement in your relationship with the franchisor including the areas of termination and renewal of your franchise. There may also be court decisions which may supersede the franchise agreement in your relationship with the franchisor including the areas of termination and renewal of your franchise.

In any arbitration or mediation involving a franchise purchased in Washington, the arbitration or mediation site will be either in the state of Washington, or in a place mutually agreed upon at the time of the arbitration or mediation, or as determined by the arbitrator or mediator at the time of arbitration or mediation. In addition, if litigation is not precluded by the franchise agreement, a franchisee may bring an action or proceeding arising out of or in connection with the sale of franchises, or a violation of the Washington Franchise Investment Protection Act, in Washington.

A release or waiver of rights executed by a franchisee may not include rights under the Washington Franchise Investment Protection Act or any rule or order thereunder except when executed pursuant to a negotiated settlement after the agreement is in effect and where the parties are represented by independent counsel. Provisions such as those which unreasonably restrict or limit the statute of limitations period for claims under the Act, or rights or remedies under the Act such as a right to a jury trial, may not be enforceable.

Transfer fees are collectable to the extent that they reflect the franchisor's reasonable estimated or actual costs in effecting a transfer.

Pursuant to RCW 49.62.020, a noncompetition covenant is void and unenforceable against an employee, including an employee of a franchisee, unless the employee's earnings from the party seeking enforcement, when annualized, exceed \$100,000 per year (an amount that will be adjusted annually for inflation). In addition, a noncompetition covenant is void and unenforceable against an independent contractor of a franchisee under RCW 49.62.030 unless the independent contractor's earnings from the party seeking enforcement, when annualized, exceed \$250,000 per year (an amount that will be adjusted annually for inflation). As a result, any provisions contained in the franchise agreement or elsewhere that conflict with these limitations are void and unenforceable in Washington.

RCW 49.62.060 prohibits a franchisor from restricting, restraining, or prohibiting a franchisee from (i) soliciting or hiring any employee of a franchisee of the same franchisor or (ii) soliciting or hiring any employee of the franchisor. As a result, any such provisions contained in the franchise agreement or elsewhere are void and unenforceable in Washington.

The undersigned does hereby acknowledge receipt of this addendum.

Dated this _____ day of _____ 20_____.

FRANCHISOR

FRANCHISEE

This addendum may also be used as a rider to the Franchise Disclosure Document.

EXHIBIT G

DEVELOPMENT AGREEMENT

DOMINO'S PIZZA FRANCHISING LLC
DEVELOPMENT AGREEMENT

Developer

TABLE OF CONTENTS

	<u>Page</u>
1. Grant of Development Rights	1
2. Term of Agreement.....	1
3. Territorial Protection.....	1
4. Development Requirements.....	1
5. Grant of Franchises	2
6. Agreements to be Executed	2
7. Management and/or Supervision of Stores	2
8. Payments	2
9. Termination.....	2
9.1 Mutual Termination	2
9.2 By DPF.....	2
10. Trade Secrets of DPF	3
11. Conflicting business Interests	3
12. Assignment by DPF	3
13. Assignment by Developer.....	3
14. Miscellaneous	3
15. Notices	4
16. Governing Law	4
17. No Waiver or Disclaimer of Reliance in Certain States	4
18. Effective Date of this Agreement	4

DOMINO'S PIZZA FRANCHISING LLC

DEVELOPMENT AGREEMENT

This Development Agreement (this "**Agreement**") is being entered into between Domino's Pizza Franchising LLC, a Delaware limited liability company ("**we**", "**DPF**" or "**us**" in this Agreement), and ("**you**" or "**Developer**" in this Agreement). If you are a corporation, partnership, limited liability company or other entity approved by us (the "**Approved Entity**"), the term "owners" in this Agreement refers to the shareholders, affiliates, partners, members or other interest holders. Unless otherwise approved by DPF, the term "Controlling Person" refers to the person who owns fifty-one percent (51%) or more of the general partnership interest of such partnership, equity and voting power of all classes of issued and outstanding capital stock of such corporation, the membership interest of such limited liability company or the voting and ownership interests of such other entity.

This Agreement sets forth the understanding of DPF and Developer with respect to your development of Domino's Pizza stores ("**Store**" or "**Stores**") in the area described in Section 1 of this Agreement, which is as follows:

1. **Grant of Development Rights.** Subject to the terms of this Agreement, DPF grants to you the exclusive right to develop Stores within the area described in Exhibit A to this Agreement (the "**Development Area**"). Enclosed malls, institutions (such as hospitals), airports, parks (including theme parks), sports arenas, convention centers and other facilities or venues where events are scheduled are excluded from the Development Area.

2. **Term of Agreement.** The term of this Agreement shall commence on the effective date of this Agreement and expire on _____ (the "**Term**").

3. **Territorial Protection.** During the Term, we agree that neither we nor our affiliates will operate (directly or indirectly) or grant a franchise for the operation of a Store to anyone else in the Development Area, provided that you: (a) timely meet the development obligations set forth in Section 4 of this Agreement; and (b) otherwise comply with the provisions of this Agreement.

4. **Development Requirements.** You agree to open the following number of Stores during the Term by the dates set forth below:

By The Following Dates

**Total Number of Stores
To Be Open and Operating**

5. **Grant of Franchises.** We will grant you a franchise for the operation of a Store at a proposed site within the Development Area upon our approval of a completed application submitted by you in the form prescribed by us, provided that we determine in our sole judgment that:

(a) you and your owners have the financial capacity and necessary skills and experience to develop and operate the Store based upon criteria established by us from time to time;

(b) the site which you have proposed for the Store within the Development Area is a suitable site for a Store based upon criteria established by us from time to time;

(c) you and your owners are in compliance with this Agreement and all Domino's Pizza Franchise Agreements; and

(d) you and your owners have furnished all information we may reasonably require in evaluating your application.

6. **Agreements to be Executed.** You and your owners agree to execute our then-current form of franchise agreement (the "**Franchise Agreement**") for each Store developed pursuant to this Agreement, providing for an initial franchise fee (or similar fee) equivalent to that provided in the then current Franchise Agreement as reflected in the policies adopted from time to time by us.

7. **Management and/or Supervision of Stores.** You must devote your full time and efforts (excepting reasonable vacation periods) to the management and/or supervision of Stores within the Development Area. If you are an Approved Entity, the Controlling Person must devote his/her full time and efforts (excepting reasonable vacation periods) to the management and/or supervision of Stores within the Development Area.

8. **Payments.** You agree to pay a Development Fee in the amount of thousand dollars and zero cents (\$,000.00).

9. **Termination.**

9.1 **Mutual Termination.** This Agreement and all rights and obligations of the parties may be terminated at any time by the mutual agreement of the parties.

9.2 **By DPF.** We may terminate this Agreement effective upon delivery of written notice to you if:

(i) you fail to meet the Development Requirements set forth in Section 4 hereof;

(ii) you or your owners fail to comply with any other provision of this Agreement;

(iii) any Domino's Pizza Area Agreement, Development Agreement or Franchise Agreement with any entity that you or your Controlling Person directly or indirectly, owns in whole or in part, is terminated by us in accordance with its terms;

(iv) you and your owners fail to maintain the financial capacity and necessary skills and experience to meet the Development Requirements and timely develop and operate the Stores required to be opened and operated under this Agreement based upon criteria established by us from time to time; or

(v) the Controlling Person of the Developer under this Agreement is not at any time the Controlling Person of all approved entities operating Stores in the Development Area.

10. **Trade Secrets of DPF.** You agree that you will maintain the absolute confidentiality of all information and methods provided by us with respect to the operation of a Store and will not use any such information in any other business or in any manner not specifically authorized or approved in writing by DPF.

11. **Conflicting Business Interests.** Neither you nor any of your owners may, during the term of this Agreement, without our prior consent, which may be withheld in our sole judgment, (i) engage, or own any interest, in any other business activity, (ii) be employed by any other business, (iii) engage in any activity which may impair your ability to fulfill your obligations under this Agreement, or (iv) engage in any conduct which, in our judgment, adversely affects the reputation of the Store or the Domino's System or the goodwill associated with the Marks or involves dishonesty, fraud, deceit, illegal conduct, misrepresentation or moral turpitude.

12. **Assignment by DPF.** This Agreement is fully assignable by us and the assignee or other legal successor to DPF's interests will be entitled to receive all of the benefits of this Agreement.

13. **Assignment by Developer.** This Agreement and the development rights contained in this Agreement are personal to you and your owners and may not be voluntarily, involuntarily, directly or indirectly, assigned or otherwise transferred or encumbered by you or your owners. For purposes of this paragraph, a sale, assignment or transfer of the interests of any owner shall be deemed an assignment or transfer of this Agreement.

14. **Miscellaneous.** Section headings are for convenience only and shall not limit the enforceability or obligations contained therein. This Agreement is binding on the parties to this Agreement and their heirs, assigns and successors in interest. By accepting this Agreement, you and your owners will be jointly and severally liable for the performance of the obligations set forth herein. Further, there are no other oral or written understandings or agreements between the parties. To the extent that this Agreement is inconsistent with any provision of any Franchise Agreement executed by you in connection with the operation of a Store, the terms of this Agreement shall govern.

15. **Notices.** All written notices permitted or required to be delivered shall be deemed so delivered when delivered to you by: (i) hand delivery, (ii) three (3) days after having been placed in the United States Mail by Registered or Certified Mail, (iii) one (1) day after being placed in the hands of a commercial courier service for next day delivery, or (iv) one (1) day after transmission by telecopy or other electronic system (including via e-mail and including e-mails which you are the only addressee or one of multiple addressees). Notices delivered pursuant to this section, including, without limitation, e-mail, shall be addressed to us at our most current principal business address or to you at the most current principal business address or home address of which we have been notified in writing. You are obligated to provide us with a correct current address for your home and business and to notify us of any change in address within ten (10) business days. If you maintain an e-mail address for your business you agree to provide us with your business e-mail address and notify us of any change in your e-mail address within ten (10) business days. You understand and agree that providing us with notice of changes in addresses (including e-mail address) shall be made in the manner provided in this section for giving notices. If you fail to timely notify us of a change of address (including e-mail, business or home), all notices sent to the prior address will be deemed properly delivered.

16. **Governing Law.** The terms and provisions of this Agreement shall be interpreted in accordance with and governed by the laws of the State in which the Development Area is predominantly located.

17. **No Waiver or Disclaimer of Reliance in Certain States.** The following provision applies only to developers and development arrangements that are subject to the state franchise registration/disclosure laws in California, Hawaii, Illinois, Indiana, Maryland, Michigan, Minnesota, New York, North Dakota, Rhode Island, South Dakota, Virginia, Washington, or Wisconsin:

No statement, questionnaire, or acknowledgement signed or agreed to by you in connection with the commencement of the franchise relationship shall have the effect of (i) waiving any claims under any applicable state franchise law, including fraud in the inducement, or (ii) disclaiming reliance on any statement made by DPF, any franchise seller, or any other person acting on behalf of DPF. This provision supersedes any other term of any document executed in connection with the franchise.

18. **Effective Date of this Agreement.** This Agreement shall take effect upon the date of its acceptance and execution by all parties hereto.

DOMINO'S PIZZA FRANCHISING LLC

DEVELOPER

By: _____

By: _____

Colleen McCormick

Its: Sr. Manager – Regulatory Affairs and
Contracts

Its:

DATED: _____

DATED: _____

COVENANTS OF OWNERS

The undersigned individuals (the "**Owners**") represent and warrant to DPF that they are all of the owners of Developer or otherwise have a direct or indirect interest in the success of Developer and that the person designated below as the Controlling Person is the Controlling Person of the Approved Entity under this Agreement. Further, to induce DPF to enter into this Agreement and grant the franchise to Developer, each of the Owners, on behalf of themselves and each of their affiliates, hereby jointly and severally guarantees the performance by Developer of its obligations under this Agreement and agrees to be bound by all of the provisions of this Agreement, provided that the liability of the Owners and their affiliates to DPF under their guarantee, other than the Controlling Person and his or her affiliates, shall be based upon the percentage of such Owner's ownership interest in Developer.

Each Owner acknowledges and agrees that:

(1) The Approved Entity shall be managed solely by the Controlling Person and that the Controlling Person may not be removed by any action of the Approved Entity or its Owners without the prior written consent of DPF;

(2) The Controlling Person shall at all times during the continuation of this Agreement have not less than fifty one percent (51%) of the equity and voting power and/or interests in the Approved Entity, unless otherwise approved in writing by DPF and any provision or term in the governing or establishing documents for the Approved Entity or any agreement between the Owners to the contrary is and shall be void for all purposes;

(3) The establishing or governing documents for the Approved Entity do not provide for a "supermajority" or other voting structure that would require the Controlling Person to have more than 51% of the equity and voting structure in order to maintain control over the Approved Entity and that no Owner(s) has any type of "veto" rights and that no voting trusts have been established which would restrict or limit the voting control of the Controlling Person. If such provision or term exists in the establishing or governing documents or other agreements, the Owners agree that it shall be void for all purposes;

(4) The Controlling Person has, as of the date of execution of this Agreement, the option, but not the obligation, exercisable on thirty (30) days notice, to purchase any or all of the equity and voting interest owned by the other Owners for a sum certain which has been determined prior to the execution of this Covenant of Owners (which may be modified by the Owners). If for any reason all Owners have not agreed upon a purchase price, the undersigned Owner(s) agree that the purchase price for their interest shall be the fair market value for all of the Domino's Pizza Stores (including Domino's Pizza Pizzazz Stores and Domino's C Stores) which the Approved Entity operates as determined by an independent appraiser selected by the Controlling Person and the Owners holding a majority of the remaining interests. If the Controlling Person and the Owners holding a majority of the remaining interests cannot agree on an independent appraiser, the Controlling Person shall select an independent appraiser and the Owners holding a majority of the remaining interests shall select an independent appraiser and those two (2) appraisers shall select a third independent appraiser. The third independent appraiser selected by the two (2) appraisers shall determine the fair market value of the equity

and voting interest owned by the Owners and the determination of the third independent appraiser shall be final and binding on all parties. If an independent appraiser is not selected through this process within sixty (60) days, DPF shall have the right to select an independent appraiser whose determination of the fair market value shall be binding and final on all parties and DPF shall incur no liability for doing so. The result of such computation shall be multiplied by the ratio that the Owner's interest bears to all outstanding ownership interests in the Approved Entity. Upon tendering the purchase price for each Owner's interest, the Owners hereby agree to convey such interest and such commitment shall be subject to enforcement by any court of competent jurisdiction through specific performance;

(5) If the Controlling Person receives a bona-fide offer and desires to sell the franchise, the Franchisee can require the other Owners to sell his/her interest in accordance with the terms of the bona-fide offer.

(6) None of the Owners has given, received or taken any security interest in this Agreement or any pledge of any equity or interest in the Approved Entity and no such security interest or pledge shall be given, received or taken during the continuation of this Agreement;

Each Owner also acknowledges and agrees, on behalf of such Owner and each of their affiliates, that DPF may apply any monies DPF may owe to any Owner or any of his/her affiliates, including, without limitation, from any profit sharing arrangements, to satisfy or offset amounts owed by Franchisee or any Owner or their affiliates to us or our affiliates under the Franchise Agreement or any other agreement. Each Owner also acknowledges and agrees, on behalf of himself/herself and each of their affiliates, that DPF shall have recourse against and be entitled to pursue the assets of any other Domino's Pizza store owned by such owner and his or her affiliates to recover or satisfy any amounts owed by Franchisee or any Owner or their affiliates to us or our affiliates under the Franchise Agreement or any other agreement.

These Covenants of Owners are intended to modify and supercede any provisions of the establishing or governing documents for the Approved Entity or other agreement between the Owners which are inconsistent with its terms. In the event of any inconsistency between these Covenants of Owners and any other agreement or governing or establishing document, these Covenants of Owners shall control. The undersigned acknowledge that the execution of these Covenants of Owners are conditions to approval by DPF of assignment or entry of this Agreement with DPF, and DPF shall be entitled to refuse to acknowledge or recognize any provisions of the governing or establishing documents of the Approved Entity which are inconsistent with the terms of these Covenants of Owners or this Agreement. Each of the Owner(s) agree that in the event that any of the governing or establishing documents for the Approved Entity are inconsistent with the provisions of these Covenants of Owners, the Controlling Person is granted the authority and power to modify or amend such provision and each Owner agrees to cast any necessary vote in favor of the amendment of such document or to execute such agreement as will reconcile these Covenants of Owners and the applicable document or agreement. The undersigned further agree that the governing and establishing documents of the Approved Entity shall not be amended, modified, deleted, novated or otherwise changed in any manner without the prior written consent of DPF.

CONTROLLING PERSON

% of Ownership

OWNER

% of Ownership

OWNER

% of Ownership

OWNER

% of Ownership

EXHIBIT A

Your Development Area is as follows:

The following territories in the :

In accordance with the provisions of Section 1 of the Development Agreement ("**Grant of Development Rights**"), enclosed malls, institutions (such as hospitals), airports, parks (including theme parks), sports arenas, convention centers and other facilities or venues where events are scheduled shall be excluded from the Area described above. We retain the right on behalf of owners and our affiliates to open a Domino's Pizza store at any of these facilities or venues or grant franchises or licenses for others to do so; provided, however, that if we determine that it is feasible or permissible for a "traditional" store to be constructed in any of these facilities or venues and we are then prepared to grant a franchise for someone to operate the store, you shall have the first option to apply for the franchise to operate the store if you meet the legal and/or venue requirements, subject to your completion of our approval process and satisfaction of our conditions for approval. You shall be granted a reasonable period of time to consider the option. "Reasonable" shall be defined on a case-by-case basis by reference to the time allowed by the venue and competitive circumstances. In the event we decide to open a Domino's Pizza store at any of these facilities or venues, or grant a franchise or license for others to do so, the Area shall be automatically adjusted to exclude such facility or venue.

If there is any conflict or overlap between the Area described above and the boundaries of any existing franchise agreement, development or area agreement, the boundaries of the areas described in the other agreements that pre-date this agreement shall control and upon discovery of any such conflict the parties will sign an amendment to this Development Agreement amending the description of the Area set out above so as to remove any conflict or overlap between the Area described above and the area described in any existing agreement. In addition, if there are maps attached to our copy of this Development Agreement outlining the Area described above, the boundaries described on the maps attached to our copy shall take precedence over the written description of the Area set out above and shall control the description of the Area of this Development Agreement. Developer and its owners agree that none of them shall have any claim for damages against us or any other franchisee as a result of any overlap in the description of Area set out above and the description of any area in an agreement that pre-dates this Development Agreement and hereby irrevocably waive all such claims.

Developer understands and acknowledges that the Territory Identifications and areas identified on the maps attached are not to be construed as the area of primary responsibility or delivery service area of any Store to be opened within the Development Area. Areas of primary responsibility or delivery service areas for each Store shall be determined in accordance with the procedures established from time to time by DPF and identified pursuant to the terms of the Franchise Agreement executed for each such Store.

**RIDER (FOR RESIDENTS OF ILLINOIS)
TO THE DOMINO'S PIZZA FRANCHISING LLC
DEVELOPMENT AGREEMENT
BETWEEN DOMINO'S PIZZA FRANCHISING LLC AND**

DATED _____, _____

1. Section 16 of the Development Agreement is hereby amended to read as follows:

16. **GOVERNING LAW.** The terms and provisions of this Agreement shall be interpreted in accordance with and governed by the laws of the State in which the Development Area is predominantly located or by the laws of the State in which you reside. However, if the jurisdictional requirements of the Illinois Franchise Disclosure Act are met independently without reference to this Paragraph; then this Agreement (and its validity, interpretation and construction), any claims arising from this Agreement, and the relationship between us and you will be governed by the laws of the State of Illinois.

DOMINO'S PIZZA FRANCHISING LLC

FRANCHISEE

By: _____
Colleen McCormick

By: _____

Its: Sr. Manager – Regulatory Affairs and
Contracts

**RIDER (FOR RESIDENTS OF HAWAII)
TO THE DOMINO'S PIZZA FRANCHISING LLC
DEVELOPMENT AGREEMENT
BETWEEN DOMINO'S PIZZA FRANCHISING LLC AND**

DATED _____, _____

1. Section 14 of the Development Agreement is hereby amended to read as follows:

14. **Miscellaneous.** Section headings are for convenience only and shall not limit the enforceability or obligations contained therein. This Agreement is binding on the parties to this Agreement and their heirs, assigns and successors in interest. By accepting this Agreement, you and your owners will be jointly and severally liable for the performance of the obligations set forth herein. Further, there are no other oral or written understandings or agreements between the parties. To the extent that this Agreement is inconsistent with any provision of any Franchise Agreement executed by you in connection with the operation of a Store, the terms of this Agreement shall govern. Nothing in this Agreement or in any related agreement is intended to disclaim the representations in the franchise disclosure document.

DOMINO'S PIZZA FRANCHISING LLC

FRANCHISEE

By: _____
Colleen McCormick

By: _____

Its: Sr. Manager – Regulatory Affairs
and Contracts

WASHINGTON DEVELOPMENT AGREEMENT ADDENDUM

The following language is added to the end of the Development Agreement:

In the event of a conflict of laws, the provisions of the Washington Franchise Investment Protection Act, Chapter 19.100 RCW will prevail.

RCW 19.100.180 may supersede the franchise agreement in your relationship with the franchisor including the areas of termination and renewal of your franchise. There may also be court decisions which may supersede the franchise agreement in your relationship with the franchisor including the areas of termination and renewal of your franchise.

In any arbitration or mediation involving a franchise purchased in Washington, the arbitration or mediation site will be either in the state of Washington, or in a place mutually agreed upon at the time of the arbitration or mediation, or as determined by the arbitrator or mediator at the time of arbitration or mediation. In addition, if litigation is not precluded by the franchise agreement, a franchisee may bring an action or proceeding arising out of or in connection with the sale of franchises, or a violation of the Washington Franchise Investment Protection Act, in Washington.

A release or waiver of rights executed by a franchisee may not include rights under the Washington Franchise Investment Protection Act or any rule or order thereunder except when executed pursuant to a negotiated settlement after the agreement is in effect and where the parties are represented by independent counsel. Provisions such as those which unreasonably restrict or limit the statute of limitations period for claims under the Act, or rights or remedies under the Act such as a right to a jury trial, may not be enforceable.

Transfer fees are collectable to the extent that they reflect the franchisor's reasonable estimated or actual costs in effecting a transfer.

Pursuant to RCW 49.62.020, a noncompetition covenant is void and unenforceable against an employee, including an employee of a franchisee, unless the employee's earnings from the party seeking enforcement, when annualized, exceed \$100,000 per year (an amount that will be adjusted annually for inflation). In addition, a noncompetition covenant is void and unenforceable against an independent contractor of a franchisee under RCW 49.62.030 unless the independent contractor's earnings from the party seeking enforcement, when annualized, exceed \$250,000 per year (an amount that will be adjusted annually for inflation). As a result, any provisions contained in the franchise agreement or elsewhere that conflict with these limitations are void and unenforceable in Washington.

RCW 49.62.060 prohibits a franchisor from restricting, restraining, or prohibiting a franchisee from (i) soliciting or hiring any employee of a franchisee of the same franchisor or (ii) soliciting or hiring any employee of the franchisor. As a result, any such provisions contained in the franchise agreement or elsewhere are void and unenforceable in Washington.

The undersigned does hereby acknowledge receipt of this addendum.

Dated this _____ day of _____ 20_____.

FRANCHISOR

FRANCHISEE

This addendum may also be used as a rider to the Franchise Disclosure Document.

ADDENDUM TO DEVELOPMENT AGREEMENT

This Addendum to Development Agreement (the “Addendum”) is being entered into between Domino’s Pizza Franchising LLC (“DPF”, “we” or “us”) and _____ (“Developer” or “you”), is dated _____, 20 and modifies and supplements the Development Agreement (the “Agreement”) by and between DPF and Developer dated _____, 20_. Any and all capitalized terms not defined herein shall have the meanings set forth in Agreement.

1. **New Store Builds and Incentives.** In exchange for you agreeing to and fulfilling the following requirements (the “Incentive Eligibility Requirements”), for traditional stores DPF will offer you a New Store Build Incentive as detailed below:

- You agree to open:
 - (i) a minimum total of one (1) new store by _____ (the “First Store Required Open By Date”);
 - (ii) a minimum total of two (2) new stores by _____ (the “Second Store Required Open By Date”);
 - (iii) a minimum total of three (3) new stores by _____ (the “Third Store Required Open By Date”);
 - (iv) a minimum total of four (4) new stores by _____ (the “Fourth Store Required Open By Date”);
 - (v) a minimum total of five (5) new stores by _____ (the “Fifth Store Required Open By Date”);
 - (vi) a minimum total of six (6) new stores by _____ (the “Sixth Store Required Open By Date”);
 - (vii) a minimum total of seven (7) new stores by _____ (the “Seventh Store Required Open By Date”);
 - (viii) a minimum total of eight (8) new stores by _____ (the “Eighth Store Required Open By Date”);
 - (ix) a minimum total of nine (9) new stores by _____ (the “Ninth Store Required Open By Date”); and
 - (x) a minimum total of ten (10) new stores by _____ (the “Tenth Store Required Open By Date”).
- The _____ () new stores shall be referred herein collectively as the “New Stores” under the Agreement. All New Stores must be approved by DPF and meet all requirements and specification in order to be considered open by DPF.
- The New Stores must be opened in _____ (Optional)

New Store Build Incentive

(to be completed as applicable)

2. **Failure to Comply With Development Requirements.** In the event you do not open any New Store by its respective Required Open By Date and do not open that New Store within the same fiscal year as the Required Open By Date in two (2) consecutive years, Developer will forfeit its rights of Development Area protection under Section 3 (“Territorial Protection”) of the Agreement.

3. **Clarification of Payments.** For purposes of clarification, pursuant to Section 8 of the Agreement, the Development Fee of _____ thousand dollars and zero cents (\$,000.00) is equal to the sum total of twenty five thousand dollars (\$25,000.00) (the “Reservation Fee”) multiplied by the total number of New Stores to be built under the Agreement pursuant to the Development Requirements (\$25,000.00 (franchise fee) multiplied by ____ () (number of Stores to be opened) = \$_ ,000.00). Such Development Fee shall initially be deferred and will be reduced by \$25,000.00 for each New Store opened under the terms of the Agreement and Addendum.

4. **Reservation Fee Payment.** Developer acknowledges that in the event Developer does not provide a copy of an approved and executed lease for a New Store to Domino’s Pizza Franchise Services within ninety (90) days after its respective Required Open By Date, Developer will be required to pay DPF the Reservation Fee. In the event Developer provides a copy of an approved and executed lease for a New Store within ninety (90) days after its respective Required Open By Date; and Developer has not begun approved construction on a New Store within one hundred eighty (180) days of its the Required Open By Date, Developer will be required to pay DPF the Reservation Fee. Further, in the event that Developer does not open all of its required New Stores under the Term of the Agreement and Addendum, Developer will be required to pay DPF the Reservation Fee for each of the New Stores not opened. All such repayments of the Reservation Fee shall be due within thirty (30) days’ of written notice from DPF.

5. **Confidentiality of Terms.** Except as prohibited by law, the Agreement, the Addendum and other details of the negotiations between the parties are confidential in nature and shall not be disclosed by you to any third party, including, but not limited to, other Domino’s Pizza franchisees.

6. **Inconsistency between Agreement and Addendum.** In the event of any inconsistency between the terms of the Agreement and this Addendum, the terms of this Addendum shall prevail.

DOMINO’S PIZZA FRANCHISING LLC

DEVELOPER:

By: _____

By: _____

Colleen McCormick

Its: Sr. Manager – Regulatory Affairs and Contracts

Its:

DATED: _____

DATED: _____

EXHIBIT H

DOMINO'S PIZZA HELP DESK SERVICES AGREEMENT

Domino's Pizza Help Desk Services Agreement

This Help Desk Services Agreement (this "Agreement"), dated _____, 20____, is by and between Domino's Pizza LLC ("Domino's") and _____("Franchisee").

WHEREAS, Domino's has agreed to offer help desk services via a toll-free telephone number and online chat (the "Services") for Domino's Pizza franchisees who own Domino's Pizza stores (each a "Store" and collectively, the "Stores") operating the Domino's PULSE computer system. The Services shall include assistance with Domino's PULSE problem resolution, answering of questions and general assistance in Domino's PULSE use.

WHEREAS, Franchisee desires to have the Stores listed on Exhibit A, as may be updated from time to time, receive the Services according to the terms of this Agreement and the rules, standards and policies set from time to time related to the Services.

NOW THEREFORE, in consideration of the premises, the mutual promises contained herein, and other good and valuable consideration, receipt of which is hereby acknowledged, the parties agree as follows:

1. Term; Termination

1.1 The term of the Agreement shall commence upon acceptance of this Agreement by Domino's at its offices in Ann Arbor, Michigan, and shall remain in force for a period of one (1) year (the "Original Term"), except as otherwise stated. At the end of the Original Term, this Agreement shall automatically renew for successive one (1) year terms (each, a "Renewal Term" and collectively with the Original Term, the "Term"), unless cancelled by either party by giving not less than sixty (60) days' written notice prior to the expiration of the Initial Term or a Renewal Term, as the case may be.

1.2 Either party may terminate this Agreement in the event of any breach by the other party which breach is not cured within thirty (30) days after receipt of written notice of such breach. If Franchisee terminates the Agreement due to the breach of Domino's to comply with the Service Level Agreements set forth in Section 2.8 below, Franchisee is entitled to reimbursement equal to the Fees paid by Franchisee for any remaining unused incidents.

1.3 Domino's may terminate the Agreement: (i) at any time on forty-five (45) day written notice to Franchisee; or (ii) in the event of nonpayment by Franchisee if such breach is not cured within ten (10) days after receipt of written notice.

1.4 Franchisee may terminate this Agreement at any time upon forty-five (45) day written notice to Domino's.

1.5 This Agreement shall terminate immediately upon (a) Franchisee's bankruptcy or insolvency; (b) the cessation of Franchisee's business operations as a Domino's Pizza franchisee or the termination or non-renewal of the Standard Franchise Agreement for the Store; or (c) the cessation of Franchisee's use of the Domino's PULSE system.

1.6 Franchisee may assign this Agreement to a purchaser of the Stores who has entered into a Standard Franchise Agreement with Domino's and agrees to be bound by the terms hereof. Franchisee shall provide Domino's with written notification that this Agreement has been assigned.

2. Fees and Charges; Invoices and Payment The fees for the Services (the "Fees") are stated in United States dollars and are assessed per incident at the rates as follows and are subject to change at any time with sixty (60) days' prior written notice to Franchisee:

Incident Type	Per Incident Fee
Call	44.00
Chat	28.00

2.1 During the Term of the Agreement, Franchisee shall be invoiced on a monthly basis for the Fees utilized by Franchisee during the prior month. Such monthly Fees shall be calculated by multiplying (i) the Per Incident Fee by (ii) the number of incidents closed by GlobalCare under that FCode during the prior month. Tickets are closed after they have been in a "Resolved" state for 30 days. For example, if GlobalCare closed two phone incidents and one chat incident in the prior month, that Franchisee would be billed $(\$44.00 \times 2) + (\$28.00 \times 1) = \$116.00$.

2.2 An incident shall be defined as an occurrence in which Franchisee, or its agent, contacts Domino's for the remedy of such occurrence. Incidents shall remain open until mutual agreement is reached between the initiator of the incident and Domino's that the issue instigating the incident has been rectified.

2.3 Franchisee agrees to accept an invoice from Domino's for all fees and remit payment via the Domino's Online Payment System or as otherwise from time to time instructed by Domino's. Domino's will send the invoice to the Franchisee's corporate address. Payment is due upon receipt of invoice, without set-off or claim. If payment is not received within thirty

(30) days from receipt of invoice Domino's may: (i) assess a charge not to exceed one and a half percent (1.5%) per month on all amounts due; and/or (ii) pursue other remedies available at law, or pursuant to other agreements between Franchisee and Domino's, or pursuant to this Agreement. All prices and payments are in U.S. dollars.

2.4 Services shall include remote support of the Domino's Pulse application, approved credit card processing applications, and the approved, standard hardware required to operate Domino's Pulse. The Services shall be available twenty-four (24) hours a day, seven (7) days a week, three hundred sixty-five (365) days a year unless notice has been sent out through Domino's communications notifying of temporary closure. Domino's communications may include but are not limited to DPZ Communication sent via email, IVR put up on the incoming call line, email sent to Franchisee email on file or the Rush published by Domino's.

2.5 Domino's represents that the following Service Levels, as measured by Services provided to all franchisees receiving Services, will be maintained through the term of this Agreement:

-Calls will be answered within seven (7) minutes at least ninety-five and one-half percent (95.5%) of the time

-First day resolution of incidents sixty-six percent (66%) of the time

-Incidents not resolved on the first call will be responded to according to the following:

- Severity One within one (1) hour; Severity One is an incident that involves the inability of the store to process orders
- Severity Two within twenty-four (24) hours; Severity Two is an incident that involves operational disruption to the store.
- Severity Three within forty-eight (48) hours; Severity Three is an incident that involves all other issues not categorized as a Severity One or Two.

3. No Warranties ALL PRODUCTS AND SERVICES DELIVERED BY DOMINOS PURSUANT TO THIS AGREEMENT ARE PROVIDED "AS IS" AND WITHOUT ANY WARRANTY, EXPRESS OR IMPLIED, INCLUDING ANY WARRANTY OF MERCHANTABILITY OR FITNESS FOR A PARTICULAR PURPOSE. THE TERMS AND CONDITIONS OF THIS AGREEMENT CONSTITUTE A SERVICE CONTRACT AND NOT A PRODUCT WARRANTY.

4. Limitation of Liability DOMINO'S SHALL HAVE NO LIABILITY WHATSOEVER UNDER THIS AGREEMENT FOR ANY DAMAGES, INCLUDING BUT NOT LIMITED TO SPECIAL, INDIRECT, CONSEQUENTIAL, INCIDENTAL, PUNITIVE, LOSS OF PROFITS OR EXEMPLARY DAMAGES UNDER ANY CIRCUMSTANCES, WHETHER BASED ON TORT OR BREACH OF CONTRACT CLAIMS OR ON ANY OTHER BASIS, EVEN IF IT HAS BEEN ADVISED OF THE POSSIBILITY OF SUCH DAMAGES. DOMINO'S SHALL NOT BE LIABLE FOR ANY MATTER BEYOND ITS REASONABLE CONTROL.

5. General

5.1 This Agreement and all addenda supersede in full all prior discussions and agreements, oral and written, between the parties relating to the Services and constitutes the entire agreement between the parties relating to the Services. This Agreement may be modified or supplemented only in writing signed by an authorized representative of each party.

5.2 Neither party shall be liable for delays in any of its performance hereunder due to causes beyond its reasonable control, including, but not limited to, acts of God, pandemics, strikes or inability to maintain labor or materials on time.

5.3 If any provision of this Agreement shall be deemed illegal or otherwise unenforceable, that portion shall be severed, and the remainder of this Agreement shall remain in full force and effect. A waiver shall be effective only if made in writing and signed by an authorized representative of both parties. The waiver of any right or election of any remedy in one instance shall not affect any rights or remedies in another instance.

5.4 All required notices under this Agreement shall be sent to the recipient party's address stated in this Agreement, unless otherwise changed in writing by the respective party. All notices shall be given by certified or registered mail, or overnight carrier. Such notices shall be deemed given on the date of receipt (or refusal) of delivery of said notice.

5.5 This Agreement shall be governed by the laws of the State of Michigan.

6.6 Neither party to this Agreement is, or shall represent itself to be, an agent, partner, or employee of the other. Nothing in this Agreement shall be interpreted or construed as creating or establishing a joint venture, agency, or partnership, or any relationship other than independent parties to a contract. Each party retains control of the day to day activities of its respective business.

6.7 Failure by either party to enforce any provision of this Agreement shall not constitute a waiver or affect its right to require future performance thereof, nor shall its waiver of any breach of any provision of this Agreement constitute a waiver of any subsequent breach or nullify the effectiveness of any provision. No waiver shall be binding

IN WITNESS WHEREOF, the parties have caused this Agreement to be executed on the date first written above.

Domino's Pizza LLC

Franchisee _____

By: _____

By: _____

Name: _____

Name: _____

Title: _____

Title: _____

Address for notices: _____

Address for notices: _____

E mail address: _____

EXHIBIT I

SALE OF ASSETS AGREEMENT

SALE OF ASSETS AGREEMENT

(Sale of Store(s) # _____)

This Sale of Assets Agreement (the "Agreement") is dated as of the ____ day of _____, and is entered into by and between **Domino's Pizza LLC**, a Michigan limited liability company, having its principal place of business at 30 Frank Lloyd Wright Drive, P.O. Box 997, Ann Arbor, Michigan 48106-0997 ("Seller"), and _____, a _____ having its principal place of business at _____ ("Buyer").

WHEREAS, Seller is the owner of assets used in the operation of _____ retail pizza Store(s), (the "Store(s)"), which are known as Store(s) # _____, located at the following addresses:

<u>Store Number(s)</u>	<u>Store Address</u>
-------------------------------	-----------------------------

_____	_____
-------	-------

and,

WHEREAS, Seller wishes to sell, and Buyer wishes to buy, the assets used in the operation of the Stores and certain associated rights and obligations, all of which are more particularly described below, pursuant to the terms and conditions of this Agreement.

NOW, THEREFORE, in consideration of the mutual covenants herein contained, and other good and valuable consideration, the receipt and sufficiency of which are hereby acknowledged, the parties agree as follows:

I. **Recitals**

The recitals set forth above are incorporated herein by reference and made a part of this Agreement.

II. **Identification and Delivery of Assets**

A. At the Closing (as defined below), Seller shall sell and Buyer shall buy the following described property used in or in conjunction with the operation of the Stores as of the close of business on _____ (hereinafter called the "Assets"):

1. All equipment used in the operation of the Stores, including but not limited to, all ovens, refrigeration units, coolers, HVAC units, tools, and utensils;
2. All office furniture and other furnishings in the Stores, including but not limited to, file cabinets, shelving, storage units, and equipment racks;
3. All interior and exterior leasehold improvements in the Stores, including but not limited to, all counters, storage, makelines, wall coverings, floorings, maps, security devices, safes, and signs;
4. Domino's PULSE store computer systems (hardware, including printers, peripherals, and license for software). Buyer has entered into the standard form of license agreement with Domino's Pizza Distribution LLC and related agreements, including the standard agreement for maintenance and help desk services, for the Domino's PULSE system in the Stores, and Buyer shall maintain the system as the Stores' computer system;
5. All other supplies and paper goods;
6. An assignment of the right to use the telephone numbers for the Stores and the related electronic equipment (including credit card processors) and all existing and pre-paid telephone listings and advertising, subject to the terms of the Standard Franchise Agreements;
7. All logo apparel in the Stores, including shirts and hats;
8. All Hot Bags and other HeatWave/Hot Bag equipment and supplies;

9. All goodwill associated with the Stores;
10. A functional credit card processing system, along with all processing equipment, including modem and the use of phone lines and numbers necessary or useful to use the equipment; and
11. Assignment of the real estate leases for the premises where the Stores are located, but only for the remainder of the current term, substantially in the form of Exhibit D.

A general summary of these items is set out on Exhibit A and the parties agree that Exhibit A may be attached to the Bill of Sale and other documents as a general description of the property and rights being sold and transferred hereunder, but failure to do so shall not affect the validity of the sale.

- B. The following assets of the Stores shall be excluded from the sale:
 1. Accounts receivable of the Stores; and
 2. Any assets or rights of Seller not directly used in the Stores.
- C. As of the close of business on _____, Seller and Buyer shall prepare a written schedule setting forth a full and complete identification and count of all items comprising the assets to be sold as described in the foregoing paragraph A of this Article II. Upon its completion, the schedule shall be attached as Exhibit B and incorporated herein by reference as the description of the Assets to be sold. Exhibit B, along with Exhibit A, may also be attached to the Bill of Sale but failure to do so shall not affect the validity of the sale.
- D. At the Closing, in consideration of the sale of the Assets by Seller to the Buyer, Buyer shall deliver to Seller, unless the same has already occurred, the following:
 1. Standard Franchise Agreements with Domino's Pizza Franchising LLC ("Franchise Agreements") and related covenants for the Stores, signed by Buyer and the Buyer's owners;
 2. Buyer's written assumption of the obligations under the contracts listed on Exhibit I, and the signed Bill of Sale;
 3. Proof of insurance coverage as required by this Agreement or the Franchise Agreements for the Stores;
 4. A certificate of incumbency and board of director and shareholder resolutions from the Buyer < or members and managers or shareholders and directors>, executed by the <President or Managing Member> of Buyer, certifying the due authorization to enter this transaction and the names of the persons having authority to do so; and
 5. A signed copy of the assignments of the lease for the premises where the Stores are located, in the form of Exhibit D;
- E. At the closing hereof Seller shall deliver possession of the Assets to Buyer unless the same has already occurred and in addition, shall deliver to Buyer the following:
 1. An assignment of any contract which Buyer has agreed to assume, in the form of Exhibit E and an authorization to use the telephone numbers for the Stores, in the form of Exhibit J, subject to Seller's rights under the Franchise Agreement;
 2. A bill of sale, in the form of Exhibit F, conveying the Assets to Buyer;
 3. Signed copies of the assignments of leases for the Stores' premises, substantially in the form of Exhibit D; and
 4. Copies of the Franchise Agreements signed by Domino's Pizza Franchising LLC.

III. Purchase Price and Terms

The purchase price for the Assets and the rights and intangibles to be transferred to Buyer, subject to the adjustments provided for in this Agreement, shall be _____ Dollars (\$ _____) (“Purchase Price”) which shall be paid by Buyer to Seller on or before Closing in the following manner:

- A. The Purchase Price of _____ (\$ _____), which shall be paid by Buyer to Seller in cash at any time prior to Closing in readily available funds by wire transfer to an account designated by Seller;
- B. Any other amount due under the Sale of Assets Agreement (including amounts for advertising - prepaid print) shall be paid in cash, or equivalent, at Closing; and
- C. The parties further specifically agree upon the Purchase Price Allocation set forth at Exhibit G and will promptly execute and deliver such other forms or documents as may be appropriate or required by any taxing authority to verify this allocation. This provision shall survive Closing.

IV. Additional Charges and Expenses; Reimbursement Items

In addition to the Purchase Price, as mentioned in paragraph III, Buyer agrees to reimburse Seller for various reimbursement items as more fully described on Exhibit H, and which result from Seller’s acquisition of the Stores on the same date as Closing. The amounts for reimbursement items will be in addition to the Purchase Price due and shall be estimated prior to Closing and paid by Buyer to Seller with the Purchase Price prior to Closing. Buyer will pay to Seller any additional amounts due and Seller will reimburse any overpayment amounts to Buyer under this agreement within fifteen (15) calendar days of Closing. If the parties do not know all of these amounts as of Closing, Seller will obtain the information after Closing and Buyer agrees to reimburse Seller for these amounts. In addition to the Purchase Price, Buyer shall pay to Seller at Closing the cost of all food and beverage items on hand at the Stores or on order for the Stores as detailed on Exhibit B.

V. Closing, Risk of Loss and Prorations

- A. The closing hereof shall take place on _____ at 10:00 a.m. at _____, or at such other time of day and location as the parties may agree. All payments to be made and documents to be delivered at the Closing shall be consummated at that time and place unless further agreement thereto is made by the parties.
- B. It is hereby acknowledged and agreed that Buyer shall have possession of the Assets and the premises as of the close of business on _____ and all risk or loss to the Assets and all obligations of whatever sort or nature arising from the ownership or operation of the Stores from and after the close of business on _____, shall be that of Buyer and Buyer will hold Seller harmless from obligations of Buyer arising out of the ownership or operation of the Stores on or after Closing. Seller shall hold Buyer harmless from claims and obligations arising out of the operation of the Stores prior to Closing.
- C. All taxes, rentals, utility bills, pre-paid advertising, real estate and personal property taxes, insurance, amounts due under service contracts or marketing related agreements assigned to and agreed to be assumed by Buyer, and other expenses and obligations of the Stores shall be prorated as of the date of Closing, as more fully described on Exhibit H.

VI. Buyer's Covenants

- A. The Assets are being purchased for use in the Buyer's business as a Domino's Pizza franchisee pursuant to the Franchise Agreements with Domino's Pizza Franchising LLC and for no other purpose and the closing of this transaction is conditioned on Buyer being approved as a franchisee and Buyer and Buyer's owners signing the Franchise Agreements and covenants of owners and any other related agreements.
- B. Buyer agrees to promptly pay all taxes and penalty and interest thereon, if any, as well as any other taxes, including sales, transfer, unemployment, real estate, and personal property and similar taxes (all taxes other than Seller's income taxes) which accrue on or subsequent to the date of closing arising out of this transaction or the operation of the Stores or use of the Assets. Buyer shall also pay before delinquent all taxes and assessments which are or may be levied against, or which may constitute a lien upon the Assets on or subsequent to the date of Closing and Buyer further agrees to specifically defend and indemnify Seller from all claims or demands arising from such taxes, including penalties and interest, or liens. In the event that Buyer receives any notice of taxes or liens relating to the Assets which are attributable to Seller's ownership of the Assets prior to the date of Closing, Buyer agrees to promptly provide any such notice and materials to Seller. Seller shall promptly pay all taxes, penalty and interest, if any attributable to Seller's ownership of the Assets and/or period of ownership of the Assets and Seller further agrees to specifically defend and indemnify Buyer from all claims or demands arising from such taxes or liens accruing prior to the date of Closing.
- C. Buyer agrees to participate in all local Co-ops, assume, and maintain local advertising and promotional programs for the Stores at the same level as required by the Co-ops, the terms of the Franchise Agreements, and any other contractual obligations concerning marketing and advertising for the Stores. In this instance Buyer agrees to the terms of the "Domino's Pizza DMA CO-OP Supplemental Contribution Agreement" for the _____ DMA, which at present require a ___% total DMA Co-op contribution for the Stores through _____, subject to such changes as are approved by the Co-op. Buyer agrees to execute and deliver to Seller at closing a Supplemental Contribution Agreement in the form of Exhibit C, evidencing the agreed Co-op contributions. In addition to the foregoing, Buyer agrees to assume and be responsible for payments due under any existing agreement and any direct mail contractor for direct mailings for the Stores. Buyer also agrees to participate in the Co-op in future years. This agreement shall survive Closing.
- D. Should Buyer fail to pay any part of the amounts herein to be paid to Seller by Buyer within fifteen (15) days after demand, Buyer shall pay to Seller interest on such delinquent payment from the due date thereof until paid at <twelve> fourteen percent (14<12>%) per annum, or at the highest legal rate if that rate is lower.
- E. Buyer is a corporation duly organized, validly existing and in good standing under the laws of the State of _____; has all requisite power to own, lease and operate its assets, properties and business and to carry on its business as a Domino's Pizza franchisee as now conducted.
- F. _____ is the President and Director of the Buyer and has the full right, power and authority to enter into, sign and deliver this Agreement and all documents related to this transaction.

G. Buyer and _____ have taken all actions necessary to authorize Buyer to enter into and perform its obligations under this Agreement and all other documents related to this transaction. This Agreement is, and as of the Closing Date this Agreement and the other documents related to this transaction will be, the legal, valid and binding obligations of Buyer, enforceable in accordance with their respective terms.

VII. Time of the Essence

Time is of the essence of this Agreement. The acceptance by either party of partial or delinquent payment or performance, or failure of either party to exercise any right or remedy shall not be a waiver of the party's obligations or rights, or constitute a waiver of any other or similar act or omission occurring at a later date. Failure at times to insist upon strict performance hereunder shall not be deemed as a waiver or bar to later insist upon strict performance of all of the terms of this Agreement.

VIII. Buyer's Inspection

Buyer acknowledges by execution hereof that Buyer has made a complete inspection of the Assets and the Stores premises which are the subject of this Agreement, is satisfied with the condition and suitability of same, and accepts the Stores premises and all the Assets "AS IS." From and after Closing, Buyer shall assume all responsibility that the Stores premises comply with all laws, ordinances, directives of the government and its agencies, and regulations, regardless of the condition at Closing. Seller makes no other warranties or any warranties as to the fitness, use or merchantability of the Stores premises or the Assets, ANY SUCH WARRANTIES BEING HEREBY EXPRESSLY NEGATED AND DISCLAIMED. Buyer may enforce in the name of Seller any warranties, if any, which may have been made by the manufacturer of the Assets. No defect, unfitness, unmerchantability or malfunction of the Assets or the Stores premises shall relieve Buyer of the obligation to make the payments or perform the obligations required hereunder. This provision shall survive the Closing.

IX. Buyer's Use of Assets; Indemnifications

Buyer shall defend and indemnify Seller against, and hold Seller harmless from, any and all claims, actions, proceedings, expenses, damages and liabilities, including attorneys' fees, arising in connection with the Assets or the Stores premises after the close of business on _____.

X. Seller's Use of Assets; Indemnifications

Seller shall defend and indemnify Buyer against, and hold Buyer harmless from, any and all claims, actions, proceedings, expenses, damages and liabilities, including attorneys' fees, arising in connection with the Assets or the Stores premises prior to the close of business on _____. Seller's liability under this section shall not exceed the Purchase Price, less Seller's cost of this transaction.

XI. Choice of Law and Litigation

This Agreement shall be governed by, and construed and enforced in accordance with, the laws of the State of Michigan. Any suit or action arising out of, related to, or in connection with this Agreement, or any instrument or document executed pursuant thereto, shall be filed and maintained in Washtenaw County, Michigan, or such other jurisdiction as to which Seller may expressly agree in writing. Buyer waives any claim that such jurisdiction is inconvenient, and hereby irrevocably authorizes and directs the judge in any court other than ones named above to promptly dismiss any such suit or action, with prejudice and at plaintiff's costs, unless Seller shall have consented in writing to the venue and jurisdiction of the suit or action.

XII. Benefit of Agreement

This Agreement shall be binding upon and shall inure to the benefit of the parties, their successors, the assigns of Seller, and the Buyer. Buyer may not assign this Agreement or delegate its duties hereunder without the prior written consent of Seller. Seller may assign its rights in this Agreement and all other documents executed in connection with this transaction.

XIII. Entire Agreement

This instrument, including the Exhibits, constitutes the entire Agreement between Buyer and Seller concerning the subject matter of this Agreement. The parties have not received, and have not relied on, any promise, statement or representation other than those expressly set forth herein in entering into this Agreement. This Agreement shall be binding when signed by an authorized agent of each party and may be executed in one or more counterparts, all of which shall constitute one original. The terms of this Agreement may be altered only by a writing signed by Buyer and Seller.

XIV. Authorization

Seller is fully authorized and empowered to release to its affiliated companies or other creditors any information concerning this Agreement, including but not limited to the type, location, condition and amount of fixtures and equipment involved; the total purchase price; the inclusive dates of the Agreement, and any other matter or fact related to the transaction or Buyer and Seller's relationship hereunder. Buyer further releases and holds Seller harmless from any liability for releasing any such information pursuant to the paragraph.

XV. Notices

Except as otherwise provided in this Agreement, all notices, demands or other communications given under this Agreement shall be in writing, and shall be either hand delivered or mailed to the address of each party as first above set forth, said mailing to be by certified United States government mail, or by recognized overnight commercial courier service, with notice to be effective upon delivery or on the second business day after mailing by certified mail. Either party may, by written direction to the other, change the address to which notice shall be sent.

XVI. Bulk Sales

Buyer and Seller both agree to waive compliance with any applicable bulk sales provision or similar law.

XVII. Compliance With Lease(s)

Buyer agrees to assume the real estate leases for the Stores, by executing an Assignment of Lease for each store premises in the form of Exhibit D attached hereto. In connection with Buyer's assumption of the leases, Buyer shall promptly pay when due all rent, additional rent, taxes, assessments and utility charges and fully comply with all of the terms of the leases for the Stores' premises. Buyer shall defend, indemnify and hold Seller harmless from any liability under the leases from and after the close of business on _____, including Seller's attorneys' fees. Unless its liability ends sooner, Seller shall have no liability under the leases for the Stores upon the first to occur of any of the following: (i) the termination or expiration of the present term of the lease; (ii) a material modification of the lease; or, (iii) Seller's release from liability under the lease. Buyer will not exercise any option to renew or extend any lease unless Seller is released from any further liability under the lease as of the expiration of the current term.

XVIII. Assumption Of Seller's Other Contractual Obligations

Buyer shall assume those contracts listed and disclosed on Exhibit I, by executing an Assignment of Contracts in the form of Exhibit E. Conditioned on the Closing, Buyer agrees to defend, indemnify and hold Seller harmless from and against any obligation, breach or other liability arising out of an assigned contract, which accrues subsequent to Closing. Seller agrees to defend, indemnify and hold Buyer harmless from and against any obligation, breach or other liability arising out of an assigned contract, which accrues prior to Closing. Seller's liability under these contracts shall end upon termination or expiration of the current term of those contracts and Buyer agrees that the terms of any renewal or continuation of these contracts by Buyer shall be without further liability to Seller.

XIX. Tenancy

Buyer acknowledges and agrees that Seller does not own the building or real estate where the Assets are located and Seller does not warrant that it has a continuing right to possession of the Stores' premises.

XX. Bill of Sale

Upon payment in full of all sums due and owing Seller hereunder and upon full and faithful performance of all the terms of this Agreement by the Buyer on its part to be performed, Seller shall execute and deliver to Buyer a Bill of Sale in the form of Exhibit F, evidencing conveyance of the Assets to Buyer.

XXI. Severability

Seller and Buyer agree that if any provision of this Agreement is capable of two constructions, one of which would render the provision illegal or otherwise voidable or unenforceable and the other of which would render the provision valid and enforceable, such provision shall have the meaning that renders it valid and enforceable. The language of all provisions of this Agreement shall be construed simply according to its fair meaning and not strictly against Buyer or Seller. It is the desire and intent of Buyer and Seller that the provisions of this Agreement be enforced to the fullest extent permissible under the laws and public policies in force. If any provision is nonetheless held to be void or unenforceable, all of the others shall remain in full force and effect.

XXII. Confirmation of Prior Acts or Performance

In the event that any act or performance required by the parties hereto has occurred prior to the date of execution of this Agreement, all of the same are hereby agreed to and ratified as being in performance hereof.

XXIII. Headings

The headings of each article are for the convenience of the parties only, are not part of this Agreement, and shall not be considered when interpreting or enforcing the terms of this Agreement.

XXIV. Proof of Proper Insurance Coverage

Notwithstanding any other provision of this Agreement, it is expressly agreed between the parties that this sale is contingent upon Buyer obtaining and maintaining proper insurance coverage for all aspects of the operation of the Stores in compliance with the Franchise Agreements and the real estate leases for the premises where the Stores are located, effective on or before Closing. Buyer agrees to furnish Seller with proof of such insurance coverage at or prior to Closing. The provisions of this article shall survive the closing. Nothing set forth in this Article shall limit any other right or remedy granted Seller.

XXV. Confidentiality

Buyer and _____ each agree to keep the terms of this Agreement confidential and to maintain this confidentiality after Closing. Information regarding this transaction may be released if required by law. Buyer and _____ may discuss this transaction with Buyer's accountant, attorney, lender and insurance agent on a need-to-know basis provided those persons are informed of this confidentiality provision and agree to keep the terms confidential.

XXVI. Continued Operation

Buyer shall be responsible for transferring or obtaining new any business licenses and permits and taking any other action necessary for the continued operation of the Stores. Any additional expense or improvements required to continue operation of the Stores shall be the responsibility of Buyer.

XXVII. Employment Matters

Seller will terminate the employment of all persons working at the Stores as of the close of business on the day before Closing and Buyer may hire those persons to continue to work on and after that date and time. With respect to each Store, Buyer has advised Seller that it intends to offer substantially similar jobs with substantially similar wages and benefits to all persons employed in the Stores just prior to the Closing, other than those individuals set forth in Exhibit K.

Seller agrees to pay all salary, vacation pay and benefits due Seller's store employees for amounts due prior to the close of business on the day before Closing, in the normal course of Seller's payroll cycle and shall indemnify Buyer from any liability therefore. It is understood that depending on the date of closing, these payments may be made after Closing. Notwithstanding the foregoing Seller shall comply with state law concerning payment of wages to terminated employees.

Buyer further agrees to cooperate with Seller regarding COBRA continuation coverage, if such cooperation is necessary.

XXVIII. Delivery Areas

Buyer is familiar with the approved delivery areas for the Stores as those areas are described on maps attached to the Franchise Agreements. Buyer agrees to independently evaluate delivery service for the Stores within thirty (30) days after Closing, and to independently determine Buyer's own delivery service policies, in accordance with standards and the Franchise Agreements. Buyer shall not assert, as a defense or as a claim, that Buyer is not familiar with any delivery area or that Seller is responsible for delivery service policies or limitations in any delivery area of the Stores from on and after Closing. Buyer agrees to make deliveries only to the addresses within the Delivery and Service Area for the Stores. Buyer also agrees not to make deliveries to any address outside of the approved Delivery and Service Area for the Stores.

XXIX. Domino's PULSE System

Buyer has entered into the standard form of License Agreement with Domino's Pizza Distribution LLC, including the standard agreement for maintenance and support services. Buyer shall, at Buyer's expense, ensure that Buyer and _____ and Buyer's employees are properly trained in the use of the Domino's PULSE system. Buyer or _____ shall be responsible for any costs associated with the training. Buyer shall subscribe for the standard maintenance and support of the system and shall pay the fees associated with maintenance and support as set out in an Addendum to the License Agreement, as the same may be modified as permitted by the License Agreement and shall pay the costs and fees when due.

XXX. Other Provisions

- A. Any other special provisions or agreements between Buyer and Seller shall be set forth on a page attached hereto and shall be signed and dated by both parties. When any provision hereof contemplates action by a party on or after Closing, that provision shall survive the Closing.
- B. The parties represent and warrant to each other that said party has the authority and legal capacity to enter this Agreement and to carry out the terms thereof and the parties intend for the other to rely on the representations and warranties contained herein.
- C. Each party shall be solely responsible for its own costs and expense (including attorneys' fees and accountants' fees) incurred in connection with this Agreement and the consummation of the transactions contemplated hereby.
- D. To the extent that either party receives funds on or after the closing date which are attributable to the other party's period of ownership (including but not limited to receipts from credit card sales, Coca-Cola rebates, and the like), then the party receiving such funds agrees to immediately notify the other party and to forward such funds to the other party.
- .
- E. Buyer authorizes Seller to insert the date and to complete any blank spaces in this Agreement and any exhibit and execution copy of any document related to this transaction in a manner that is consistent with the circumstances and the agreement of the parties.

XXXI. JURY WAIVER.

BUYER AND SELLER HEREBY KNOWINGLY, VOLUNTARILY, INTENTIONALLY, UNCONDITIONALLY AND IRREVOCABLY WAIVE, TO THE FULLEST EXTENT PERMITTED BY APPLICABLE LAW, ANY AND ALL RIGHT TO TRIAL BY JURY IN ANY PROCEEDING ARISING OUT OF, RELATING TO, OR IN CONNECTION WITH THIS AGREEMENT OR THE TRANSACTION CONTEMPLATED HEREBY.

The parties acknowledge reading, understanding and fully agreeing to all of the terms hereof.

[Remainder of Page Left Intentionally Blank]

IN WITNESS WHEREOF, the parties have hereunto executed this Agreement as of the day and year first above written.

Witness

Witness:

Seller: Domino's Pizza LLC

By: _____
_____, _____

Buyer: _____, a _____

By: _____
_____, its _____

Buyer's FEIN: _____

SALE of ASSETS AGREEMENT

EXHIBIT A

SUMMARY OF ITEMS OF PROPERTY IN THE STORES

1. All equipment used in the operation of the Stores, including but not limited to, all ovens, refrigeration units, coolers, HVAC units, tools, and utensils;
2. All office furniture and other furnishings in the Stores, including but not limited to, file cabinets, shelving, storage units, and equipment racks;
3. All interior and exterior leasehold improvements in the Stores, including but not limited to, all counters, storage, makelines, wall coverings, floorings, maps, security devices, safes, and signs;
4. Domino's PULSE Store computer systems (hardware, including printers and peripherals and license for software) and credit card processing machines and system;
5. All supplies and paper goods;
6. An assignment of the right to use the telephone numbers and all existing and pre-paid telephone listings and advertising, subject to the terms of the Franchise Agreements;
7. All logo apparel in the Stores, including shirts and hats; and
8. All Hot Bags and other Heat Wave and Hot Bag equipment and supplies.

IN ADDITION TO AN IDENTIFICATION AND COUNT OF ITEMS COMPRISING THE "ASSETS" TO BE COMPLETED BY THE PARTIES ON THE DAY BEFORE CLOSING, INITIALED, AND ATTACHED TO THE AGREEMENT AS PART OF THIS EXHIBIT "A"

Store Numbers

Store Addresses

Buyer

Seller

SALE of ASSETS AGREEMENT
EXHIBIT B

[INVENTORY AND COUNT SHEET TO BE COMPLETED _____ AND ATTACHED]

SALE of ASSETS AGREEMENT
EXHIBIT C
FORM OF DMA SUPPLEMENTAL CO-OP CONTRIBUTION AGREEMENT

Domino's Pizza
DMA CO-OP Supplemental Contribution Agreement

DMA Co-op Name: _____

Date of Meeting: _____

Name of Franchisee: _____

The Franchise agrees to make supplemental Co-op contributions for the franchisee's Stores listed below, subject to such changes as may be approved by the CO-OP:

Stores #	Total DMA Co-op Contribution
	_____% through _____

Franchisee authorizes collection of contributions at the percentage rate shown for each Stores listed above for the time period set out above, subject to changes approved by the CO-OP. *(The percentage rate shown above includes both the contractual obligation under the Franchise Agreements and the supplemental contribution.)*

This agreement to contribute the supplemental contribution is in addition to any other obligation that the Stores or the Franchisee may have to contribute under the Franchise Agreements.

By _____

 Date

Proxy: Yes / No
 (Circle one)

 Representative of Franchisee

 Acknowledged By

SALE of ASSETS AGREEMENT
EXHIBIT D

FORM OF ASSIGNMENT OF REAL ESTATE LEASE

(Store # _____)

On _____, Domino's Pizza _____ entered into a lease (the "Lease") with _____, ("Landlord") for premises located at _____. The Lease, as modified, assigned and extended through _____, ("Present Term"), is hereinafter referred to as the "Lease". FOR VALUE RECEIVED, Lessee hereby sells, assigns, transfers and sets over unto _____, a _____ ("Assignee"), and a Domino's Pizza franchisee, the rights and interest of Lessee in and to the Lease, except for the right to extend the Lease beyond the Present Term where Assignee is not released from further liability.

This Assignment shall not release Lessee from liability under the Lease until the end of the Present Term of the Lease, or such sooner time as may be permitted under the Lease, whether by payment of a termination fee or otherwise, and at that time Lessee shall be released from any further liability under the Lease. This Assignment may be signed in counterparts.

Assignee assumes all the obligations of Lessee under the Lease and agrees to perform all the terms, covenants and conditions, and pay the rent as therein stipulated, pursuant to this assignment. In addition, Assignee has the right to any and all options to renew the Lease contained therein.

Lessee agrees to defend and indemnify Assignee for any liability arising under the Lease prior to the date hereof and Assignee agrees to defend and indemnify Lessee from any liability arising under the Lease on or after the date hereof.

This agreement may be executed in one or more counterparts, each of which constitutes an original and is admissible in evidence, and all of which constitute one and the same agreement.

<This Assignment is effective as of _____, ____.>

Dated _____.

Domino's Pizza LLC

By: _____
_____, _____

Accepted by _____

Landlord consents to the assignment and assumption of this Lease as of _____ according to the terms set out above and agrees that as of that date, Domino's Pizza LLC is not in default under the Lease.

<Confirm any lease deposits held by Landlord>

Landlord:

By: _____

Name: _____

Title: _____

Date: _____

SALE of ASSETS AGREEMENT
EXHIBIT E

FORM OF ASSIGNMENT OF CONTRACT

FOR VALUE RECEIVED, as of _____, the undersigned Domino's Pizza LLC, a Michigan limited liability company, ("DPLLC"), hereby sells, assigns, transfers, and sets over unto _____, a _____ ("Assignee"), all its right, title and interest to the present term of the contracts listed on Exhibit I to a Sale of Assets Agreement dated _____, between DPLLC and Assignee. Copies of the contracts being assigned may be attached hereto and incorporated herein. Failure to attach the contracts shall not affect the validity of this assignment.

As of the date and time hereof, Assignee assumes all the obligations of DPLLC under the terms of all of the contracts listed on Exhibit I and agrees to perform all the terms, covenants and conditions, and pay all amounts due thereunder.

Dated as of _____.

Domino's Pizza LLC

By: _____

Its: _____

Accepted by _____, a _____ as of _____.

By : _____
_____, _____

My commission expires _____

Accepted By _____, according to the terms hereof, as of _____.

By: _____

SALE of ASSETS AGREEMENT
EXHIBIT G
PURCHASE PRICE ALLOCATION

Store #	Equipment	Leaseholds	Goodwill	Supplies	TOTAL
Total	\$	\$	\$	\$	\$

SALES TAX:

In addition to the Purchase Price Buyer will pay to Seller at Closing all sales and other taxes of a similar nature, which the parties estimate to be in the amount of \$_____.

FRANCHISE TRANSFER FEE:

In addition to the Purchase Price, Buyer will pay to Seller, prior to Closing, a franchise transfer fee in the amount of \$_____.

Buyer

Seller

SALE of ASSETS AGREEMENT
EXHIBIT H
DETAILED EXPLANATION OF PRORATIONS AND EXPENSES

Prorations for Stores: <Buyer Name>		Franchisee owes DPLLC
Trash & Pest Prorated		\$ 0.00
Coke Rebate-Semi Annual		
Landlord Prorations – Real Property Tax		
School & Property Tax		
Utilities		
Phone Equipment Maintenance		
RTG Pulse Hardware Maintenance		
Pulse Annual Software Enhancement Fee		
VPN Monitoring Fee		
Advertising-Prepaid Print		
Advertising		
Cash in till		
Security deposit paid to landlord		
TOTAL		\$

Buyer

Seller

SALE of ASSETS AGREEMENT

EXHIBIT I

LIST OF CONTRACTS/OBLIGATIONS/AGREEMENTS TO BE ASSUMED BY BUYER

SALE of ASSETS AGREEMENT
EXHIBIT J

(Form to Be Supplied by Local Telephone Company)

SALE of ASSETS AGREEMENT
EXHIBIT K

LIST OF INDIVIDUALS

EXHIBIT J

DOMINO'S PULSE SOFTWARE LICENSE AGREEMENT

**Form of
Domino's Pulse SOFTWARE LICENSE AGREEMENT**



between

Domino's Pizza Distribution LLC
24 Frank Lloyd Wright Drive
P.O. Box 485
Ann Arbor, MI 48106 ("DPD")

And

CONTROLLING OWNER: «FranFormalName»

Address: «FranOfficeLabel»

Telephone: (xxx) xxx-xxxx

This License Agreement (the "Agreement") by and between Domino's Pizza Distribution LLC, its parents, subsidiaries and affiliates and «FranFormalName» (the "Controlling Owner") and all corporations partnerships, limited liability companies or other business entities (each, an "Owned Entity", as a group, the "Owned Entities" and together with the Controlling Owner, the "License Holder") owned by Controlling Owner that own or operate Domino's Pizza stores, is made on «Today» and is effective upon full execution by both parties, and is subject to the terms and conditions below. Attachments A, B and C are incorporated into this Agreement.

ACCEPTED BY:

Domino's Pizza Distribution LLC

Controlling Owner: «FranFormalName»

Signature: _____

Signature: _____

Name: Kevin S. Morris
Title: EVP, General Counsel, Corp. Secretary

Name: «FranFormalName»
Individually and as authorized representative of
each Owned Entity
FCode: F_____

Date: _____

Date: _____

1. Grant of License

1.1 Domino's Pizza Distribution LLC ("DPD") grants to License Holder a limited, nonexclusive license to use executable copies of the software products listed on attachment A ("Software") at the Domino's Pizza store owned by License Holder (each, a "Store" and collectively, the "Stores"). License Holder agrees not to move the Software from that address where it is installed except with the prior written consent of DPD.

DPD shall deliver to License Holder one (1) set of the Software for each of the Stores, in object code form, including the applicable user documentation (in either electronic interface, hard copy or other format). Unless the context indicates otherwise, all references to the Software herein shall be deemed to refer to and include the applicable user documentation. DPD, or its designated representative, shall install the Software on certified hardware either in each Store or at a designated location from which the hardware with installed Software will be delivered to a Store. Unless License Holder notifies DPD in writing to the contrary, License Holder shall be deemed to have accepted the Software ten (10) days after the Installation Date.

1.2 The Software shall only be used by License Holder in connection with License Holder's own internal business activities as a Domino's Pizza franchisee or licensee and only at the Store where the Software is required or permitted to be used in accordance with this Agreement. For clarification purposes, the Software shall only be used in connection with the sale of Domino's Pizza products without the prior written consent of DPD.

1.3 License Holder may transfer the Software to another Store with DPD's prior written approval, which shall not be unreasonably withheld. If the License Holder was provided with a copy of the Software at a discounted amount, DPD reserves the right to charge the then current price of the Software prior to the transfer/sale of the store or Software. DPD may condition its consent upon License Holder's written certification that all copies of the Software at the original Store have either been destroyed or transferred to the new Store.

1.4 License Holder shall not copy the Software, in whole or in part, except for disaster recovery, program error verification, and for back-up purposes. License Holder shall maintain and furnish to DPD, upon reasonable request, competent records of the number and location of all copies of the Software, in whole or in part.

1.5 License Holder must maintain all proprietary notices imposed by DPD in the Software, including all copies thereof. License Holder shall not, and shall not allow any third party, including License Holder's employees, to: (i) reverse engineer, decompile, modify, adapt, translate, disassemble or attempt to ascertain or discover any source code or underlying ideas or algorithms of the Software, merge the Software with any other work or create derivative works based on the Software; (ii) use or provide the Software for the benefit of any third party; (iii) reset or disable the Software except with the prior written consent of DPD; or (iv) except with the prior written consent of DPD, which shall not be unreasonably withheld, use for call or order centers. Interfaces and other additional functions that are external to the Software and its database may be created only with the prior written consent and at the sole discretion of DPD.

1.6 License Holder may assign this license to a qualified purchaser (as defined by DPD) of any of the Stores as provided in License Holder's Franchise Agreement(s) or License Agreement(s) with the written approval of DPD. There will be no assignment fee due from License Holder as a result of such assignment. Except as provided in this Section 1.6, License Holder shall not transfer, assign or sublicense its rights or obligations under this Agreement to any other party, in whole or in part, without the prior written consent of DPD,

which consent shall not unreasonably be withheld or delayed. If the License Holder was provided with a copy of the Software at a discounted amount, DPD reserves the right to charge the then current price of the Software prior to the transfer/sale of the store or Software. Any such prohibited assignment shall be void. In the event of a Store sale or transfer, DPD reserves the right to issue a new Agreement to the new franchisee or licensee. If the License Holder is replaced with a new License Holder but the Controlling Owner remains the same, this Agreement shall continue and such new License Holder shall assume all the obligations and rights hereunder,

2. Term; Termination

2.1 The term of the Agreement shall commence upon acceptance of this Agreement by DPD at its offices in Ann Arbor, Michigan, and shall continue until (i) License Holder is no longer a Domino's Pizza franchisee or licensee and ceases using the Software; (ii) DPD gives written notice that Domino's Pulse is no longer the appropriate computer system for use in all domestic Domino's Pizza stores and License Holder ceases using the Software after that notice; or (iii) Domino's Pulse (or a potential successor or substitute system as designated by DPD, which may be based on similar or entirely different methodologies or technology) is no longer used in a majority of company-owned stores, and upon License Holder ceasing to use the Software.

2.2 Either party may terminate this agreement in the event of any material breach by the other party which material breach is not cured within thirty (30) days after receipt of written notice of such material breach, except as otherwise provided in Section 4.3

2.3 DPD may terminate this Agreement in the event of nonpayment by License Holder of the fees and charges described below in section 3, if such breach is not cured within ten (10) days after receipt of written notice.

2.4 This Agreement shall terminate immediately upon (a) License Holder's bankruptcy or insolvency; (b) the cessation of License Holder's business operations as a Domino's Pizza franchisee or licensee; (c) for any individual Store, the termination or expiration and nonrenewal of the Franchise Agreement or License Agreement for the operation of the Store where the Software is required to be used in accordance with this Agreement; or (d) for the reasons set out below in section 4.3.

2.5 Upon any termination of the Agreement, License Holder shall within thirty (30) days return the Software to DPD or, at DPD's direction, destroy the Software, including user documentation, and shall also warrant in writing that all copies and partial copies have been returned to DPD or have been destroyed. The provisions of this Agreement relating to title and nondisclosure as set forth in Section 4 shall survive any termination of this Agreement. This provision does not require License Holder to destroy License Holder's data and records but License Holder may not retain any customer data, including, but not limited to, customer information and order history. License Holder may copy and retain License Holder's records and data.

2.6 License Holder will not be in default under its Domino's Pizza Franchise Agreement or License Agreement for failing to use Domino's Pulse if: (i) License Holder validly terminates this Agreement according to section 2.2; or, (ii) DPD terminates this Agreement as a result of a claim of infringement by a third party after DPD determines that it is not commercially reasonable to procure the right for License Holder to continue to use the Software, or replace or modify the Software so as to make it noninfringing pursuant to section 5.2; or, (iii) License Holder is enjoined or prohibited by law or regulation from using the Software through no fault of License Holder.

3. Fees and Charges; Payment; Taxes

3.1 The License fees, annual Software enhancement fees, and other charges set forth in Attachment A shall be invoiced by DPD upon delivery of the Software to License Holder. All license fees, annual Software enhancement fees, and other charges are due thirty (30) days after date of invoice, without set-off or claim. A charge not to exceed one and a half percent (1 ½%) percent per period may be assessed on late payments. All prices and payments are in U.S. dollars.

3.2 License Holder shall also pay sums equal to all shipping and handling charges (such handling charges shall be without markup to DPD or rebate to DPD), and all custom duties and taxes, paid or payable, however designated, arising from the licensing or use of the Software by License Holder, but exclusive of DPD's franchise taxes and federal, state and local taxes based on DPD's net income.

4. Title; Nondisclosure

4.1 Title to and ownership of the Software, and all copies, partial copies and any and all revision and modifications thereto, shall remain with DPD and/or with the respective manufacturer or author. All rights to patents, copyrights, trademarks and trade secrets in the Software or any modifications shall remain with DPD and/or with the respective manufacturer or author.

4.2 License Holder shall take all steps necessary to maintain the Software in confidence and shall not, nor shall it permit its employees or its agents or consultants to sell, transfer, disclose, display or otherwise make accessible the Software, or any copies thereof, in whole or in part to any third party. The internal dissemination of the Software or any information relating thereto by License Holder to its agents and consultants shall require a written agreement to maintain the confidentiality of the Software and information and restrict the use thereof.

4.3 Breach of any provision of this Section 4 shall be the basis for immediate termination by DPD of this Agreement and the license(s) granted herein.

5. Limited Warranty

5.1 Provided that License Holder has currently paid for annual Software Enhancement Services and uses the Software in the manner required by this Agreement and the applicable documentation, the Software as delivered by DPD will perform in all material respects in accordance with the then current applicable user documentation delivered by DPD (in either electronic interface, hard copy or other format). DPD's sole obligation and liability under this Section 5.1 shall be to replace or correct the Software so that it will perform in substantial conformance with the applicable user documentation. In the event DPD fails or is unable for any reason to replace or correct the Software so that it will so perform, DPD shall, as its sole obligation and liability, refund the applicable license fee paid by the License Holder, upon return of the Software, less an amount equal to ten percent (10%) of such fee for each twelve (12) month period, or part thereof, since the license term commencement date.

5.2 DPD warrants that it has the right to authorize the use of the Software by License Holder under this Agreement. DPD shall hold harmless and defend License Holder against suits based on any claim that the delivered Software under this Agreement infringes on any United States patent, copyright, trademark or other proprietary right, provided that License Holder gives DPD prompt written notice of such suits and permits DPD to control the defense and the settlement thereof. In the event, as a result of any such claim of infringement, License Holder is enjoined from using the Software, or if DPD believes that the Software is likely to become the subject of a claim of infringement, DPD at

Its option and expense may procure the right for License Holder to continue to use the Software, or replace or modify the Software so as to make it noninfringing, provided that the performance thereof is not adversely affected in a material manner. If DPD, in its sole discretion, determines that neither of these options is commercially reasonable, DPD may terminate the license granted herein with the respect to the affected Software and, as its sole liability, except for indemnities stated above in this Section 5.2, refund to License Holder the applicable license fee to the extent then paid by License Holder upon return of the affected Software, less an amount equal to ten percent (10%) of such fee for each twelve (12) month period, or part thereof, since the license term commencement date.

5.3 IN THE EVENT THAT LICENSE HOLDER, EMPLOYEE, OFFICER, OR AGENT OF LICENSE HOLDER MODIFIES ANY PORTION OF THE SOFTWARE WITHOUT DPD'S PRIOR WRITTEN APPROVAL, WARRANTIES WITH RESPECT TO THAT PORTION OF THE SOFTWARE ARE VOIDED AND WARRANTIES, IF ANY, WITH RESPECT TO THE UNMODIFIED PORTION OF THE SOFTWARE ARE VOIDED SHOULD THE FAILURE OF THE UNMODIFIED PORTION TO CONFORM TO THE FUNCTIONAL SPECIFICATIONS HAVE BEEN DIRECTLY AND PROXIMATELY CAUSED BY THE MODIFICATION.

DPD DOES NOT AND CANNOT WARRANT THE RESULTS THAT MAY BE OBTAINED BY USE OF THE SOFTWARE OR THAT THE FUNCTIONS WILL BE UNINTERRUPTED OR ERROR OR BUG FREE. DPD MAKES NO WARRANTIES EITHER EXPRESS OR IMPLIED WITH RESPECT TO ANY THIRD PARTY SOFTWARE.

5.4 DPD HEREBY DISCLAIMS ALL OTHER WARRANTIES, EXPRESS AND IMPLIED, INCLUDING THE WARRANTY OF MERCHANTABILITY AND THE WARRANTY OF FITNESS FOR USE OR FOR A PARTICULAR PURPOSE. THE WARRANTIES SET FORTH IN THIS SECTION 5 SHALL CONSTITUTE DPD'S SOLE AND EXCLUSIVE LIABILITY AND THE REMEDIES SET FORTH IN THIS SECTION 5 SHALL CONSTITUTE LICENSE HOLDER'S SOLE AND EXCLUSIVE REMEDIES FOR ANY ACTION, WHETHER BASED IN CONTRACT OR IN TORT.

5.5 Some states and jurisdictions do not allow limitations on duration of an implied warranty. Consequently, the above limitations may not apply to License Holder with respect to a Store located in those states.

6. Limitation of Liability

6.1 DPD SHALL HAVE NO LIABILITY WHATSOEVER FOR SPECIAL, INDIRECT, CONSEQUENTIAL, INCIDENTAL, PUNITIVE, OR EXEMPLARY DAMAGES UNDER ANY CIRCUMSTANCES, WHETHER BASED ON TORT OR BREACH OF CONTRACT CLAIMS OR ON ANY OTHER BASIS, EVEN IF IT HAS BEEN ADVISED OF THE POSSIBILITY OF SUCH DAMAGES. IN NO EVENT SHALL DPD'S LIABILITY, EXCEPT AS STATED IN SECTION 5.2, EXCEED THE INITIAL LICENSE FEE PAID BY LICENSE HOLDER TO DPD.

6.2 DPD SHALL HAVE NO LIABILITY FOR (a) LOSS OF DATA OR OTHER LOSS RELATED TO FAILURE TO BACK UP THE DATA; OR (b) ANY FAILURE OF ANY MEDIA RESULTING FROM ABUSE, ACCIDENT, OR MISAPPLICATION OF THE HARDWARE, SOFTWARE, DOCUMENTATION OR SYSTEM; OR (c) LICENSE HOLDER'S FAILURE TO INCORPORATE IN THE SOFTWARE ANY UPDATES OR CORRECTIONS WHICH DPD HAS PROVIDED TO LICENSE HOLDER.

7. Support Services

7.1 License Holder shall enter into an agreement with DPD, one of its affiliates or a third party supplier certified by DPD for Help Desk and Software support services, during the term of this Agreement, or for such other shorter period of time as DPD may agree. License Holder acknowledges that in order to obtain full benefit of the Help Desk and Support Services, License Holder shall not have modified the Software, failed to incorporate in the Software any updates which DPD has provided to License Holder, or failed to use the then currently support version(s) of the Software.

License Holder may negotiate directly with any Help Desk and Support Service certified by DPD. DPD will, however, attempt to obtain the best prices and cost structures for Help Desk Services by negotiating with providers based on, among other things, volume discounts, and License Holder agrees not to unreasonably impair DPD's ability to do so.

8. Dispute Resolution

8.1 The parties desire to resolve disputes arising out of this Agreement without litigation. Accordingly, except for action seeking injunctive relief related to the purposes of this Agreement, or suit to compel compliance with this dispute resolution process, the parties agree to use the following alternative dispute resolution procedure as their sole remedy with respect to any controversy or claim arising out of or relating to this Agreement or its breach.

8.2 At the written request of a party, each party will appoint a knowledgeable, responsible nonlawyer business representative to meet and negotiate in good faith to resolve any dispute arising under this Agreement. The location, format, frequency, duration, and conclusion of these discussions shall be left to the discretion of the representatives. Upon agreement, the representatives may utilize other alternative dispute resolution procedures such as mediation to assist in the negotiations. Discussions and correspondence among the representatives for purposes of these negotiations shall be treated as confidential information developed for purposes of settlement, exempt from discovery and production, which shall not be admissible in the arbitration described below or in any lawsuit without the concurrence of all parties. Documents identified in or provided with such communications, which are not prepared for purposes of the negotiations, are not so exempted, and may, if otherwise admissible, be admitted in evidence in the arbitration or lawsuit.

8.3 If the negotiations do not resolve the dispute within sixty (60) days of the initial written request, or such other period of time as agreed to by the parties but not to exceed 180 days, the dispute shall be submitted to binding arbitration by a single arbitrator selected pursuant to the Commercial Arbitration Rules of the American Arbitration Association. A party may demand such arbitration in accordance with the procedures set out in those rules. The provisions of this Agreement shall control in the event there is any conflict between this Agreement and the Commercial Arbitration Rules of the American Arbitration Association. Discovery shall be controlled by the arbitrator and shall be permitted to the extent set out in this section. Each party may submit in writing to a party, and that party shall so respond, to a maximum of any combination of thirty-five (35) (none of which may have subparts) of the following: interrogatories, demands to produce documents, and requests for admission. Each party is also entitled to take the oral deposition of one individual of another party. Additional discovery may be permitted upon mutual agreement of the parties. The arbitration hearing shall be commenced within sixty (60) days of the demand for arbitration. The arbitration shall be held in Ann Arbor, Michigan. The arbitrator shall control the scheduling so as to process the matter expeditiously. The parties may submit written briefs. The arbitrator shall rule on the dispute by issuing a written opinion within thirty (30) days after the close of

hearings. The arbitrator shall follow the law of the State of Michigan without regard to its conflict of law provisions. The times specified in this section may be extended upon mutual agreement of the parties or by the arbitrator upon a showing of good cause. In no event shall an award in an arbitration initiated under this section exceed the Limitations on Liability set out above in section 6 and no award shall include any equitable relief.

Judgment upon the award rendered by the arbitrator may be entered in any court having jurisdiction within one year from the date of the award, subject to either party's right to apply to the court to vacate the award within 21 days after delivery of a copy of the award to the applicant.

On application of a party, the court shall vacate an award if: (i) the award was procured by corruption, fraud, or other undue means; (ii) there was evident partiality or misconduct prejudicing a party's rights; (iii) the arbitrator exceeded his or her powers (including a material error in law or failure to give a fair and plain meaning to the License Agreement); or (iv) the arbitrator refused to postpone the hearing on a showing of sufficient cause, refused to hear evidence material to the controversy, or otherwise conducted the hearing to prejudice substantially a party's rights.

8.4 Each party shall bear its own costs of the procedures set out in section 8.2 and 8.3. A party seeking discovery pursuant to the procedures in section 8.3 shall reimburse the responding party for the costs of production of documents (including search time and reproduction costs). The parties shall equally split the fees of the arbitration and of the arbitrator provided for in subsection 8.3. If any action is brought seeking injunctive relief related to the purposes of this Agreement, or to compel compliance with this dispute resolution process, as contemplated by section 8.1, the prevailing party in such an action shall be entitled to an award of its reasonable attorney's fees and costs of litigation.

9. Transfer of Data

License Holder agrees that DPD is merely accepting data from License Holder as it exists on License Holder's computer system, without independent review or verification, and that DPD has no duty to do so. By accepting data from License Holder's system DPD is not approving the customer addresses as being within License Holder's Delivery and Service Area. Nothing herein shall prevent Domino's Pizza Franchising LLC ("DPF") or its affiliates, successor or assigns from strictly enforcing all of the terms of the Franchise Agreement or License Agreement for the Store. License Holder waives any claim that DPD has breached any duty disclaimed by DPD in this paragraph.

10. License Holder's Indemnity

License Holder, at its own cost, shall indemnify and defend DPD and its affiliates and their respective agents, officers, directors, employees, successors and assigns against any and all suits, proceedings, hearings, investigations, charges, complaints, claims, demands, injunctions, judgments, orders, rulings, damages, penalties, fines, costs, amounts paid in settlement, liabilities, obligations, taxes, expenses, and fees, including court costs and reasonable attorneys' fees and expenses (as same are incurred) which arise out of or in connection with:

(a) a claim or threatened claim which is or may be brought by any third party, which is based in whole, or in part, upon an assertion that this Agreement infringes upon, or interferes with, the contractual relationship or other rights between such third party and License Holder;

(b) all claims that result from any copyright or other infringements of third party rights that occur as a result of License Holder providing its own technical support and maintenance or from any errors or malfunctions that occur as a result of License Holder providing its own technical support and maintenance;

(c) all claims arising out of the performance or nonperformance by License Holder and its employees of the obligations arising under this Agreement; or,

(d) all claims arising out of data furnished or made available to DPD for uploading or converting to the Domino's Pulse system, or transferring from License Holder's old system to a new system, including the accuracy of delivery addresses and whether the addresses are located within or outside the boundaries of the License Holder's approved Delivery and Service Area.

11. License Holder Data

License Holder agrees that DPD, DPF (and their affiliates and successors and assigns) may, at any time, have full access, both on-site and from a remote location, to all of License Holder's computer data, equipment and systems containing any and all of the information, records and reports required to be maintained by License Holder pursuant to its Franchise Agreement or License Agreement and to use the data in the evaluation of product and service, store performance, tests, EBITDA performance, and as an analytical tool to improve the operation of the Domino's system. DPD will use the same degree of care to protect against the unauthorized use of the information by third parties as it does with respect to its own information of a similar type. In addition, DPD is responsible for the security of cardholder data that DPD possesses or stores, processes or transmits on behalf of the License Holder, or to the extent that they could impact the security of the License Holder's cardholder data environment.

12. Use of Telephone Numbers

License Holder may receive a marketing list from an outside vendor which contains telephone numbers of potential customers of License Holder for use in connection with the Software licensed pursuant to this agreement. Any such list is included within the definition of "Customer List" as that term is defined in the Franchise Agreement. License Holder acknowledges that the list and the telephone numbers have not been compared to the National Do Not Call Registry and that some of the names on the list may have placed their telephone numbers on the National Do Not Call Registry.

License Holder agrees that it will only use the information contained in the marketing list described above in manner consistent with and for purposes permitted by law. License Holder agrees not to call any telephone number on the marketing list for telemarketing purposes unless License Holder first obtains access to the National Do Not Call Registry on its own behalf and abides by the restrictions placed on calling telephone numbers that appear on the Do Not Call Registry.

License Holder agrees to defend, indemnify and hold DPD, the supplier of the marketing lists and the supplier of the telephone numbers, and their directors, officers, agents, employees, contractors, licensors, and affiliated companies, harmless from any liability for any loss or injury arising out of, or caused in whole or in part by License Holder's use of the information provided in the marketing list described above.

13. Technology Advisory Board

DPD will maintain a Technology Advisory Board ("TAB") consisting of Domino's Pizza Franchisees and/or Licensees selected by DPD. DPD will from time to time present DPD's plans for the direction and prioritization of future development of the Software and related

technologies to the TAB. The TAB will review these plans, provide the advice of the TAB, and collaborate with DPD on these future initiatives.

14. Procedures Review

DPD will use a "Procedures Review" whereby approximately once each year, DPD will have the key enhancement, maintenance, and support expenditures on Pulse and related technologies (including but not limited to Domino's Real Time) from collected enhancement fees reviewed by independent auditors. DPD will review the results of the independent auditor review with the TAB for purposes of demonstrating that annual Software enhancement fees are spent only on the enhancement, maintenance, and support of Domino's Pulse and related store and internet-based technologies.

15. General

15.1 This Agreement and all addenda supersedes in full all prior discussions and agreements, oral and written, between the parties relating to the Software and constitutes the entire agreement between the parties relating to the Software. This Agreement may be modified or supplemented only in writing signed by an authorized representative of each party.

15.2 Neither party shall be liable for delays in any of its performance hereunder due to causes beyond its reasonable control, including, but not limited to, acts of God, strikes or inability to maintain labor or materials on time.

15.3 If any provision of this Agreement shall be deemed illegal or otherwise unenforceable, that portion shall be severed, and the remainder of this Agreement shall remain in full force and effect. A waiver shall be effective only if made in writing and signed by an authorized representative of both parties. The waiver of any right or election of any remedy in one instance shall not affect any rights or remedies in another instance.

15.4 All required notices under this Agreement (except for the notice in section 2.1) shall be sent to the recipient party's address stated in this Agreement, unless otherwise changed in writing by the respective party. Notices to DPD shall be sent to the attention of the Chief Information Officer and notices to the License Holder shall be sent to the attention of the person signing this Agreement on behalf of the License Holder. All notices shall be given by certified or registered mail, or overnight carrier or via facsimile or other electronic system. Such notices shall be deemed given on the date of receipt (or refusal) of delivery of said notice.

15.5 This Agreement shall be governed by the laws of the State of Michigan.

15.6 Neither party to this Agreement is, or shall represent itself to be, an agent, partner, or employee of the other. Nothing in this Agreement shall be interpreted or construed as creating or establishing a joint venture, agency, or partnership, or any relationship other than licensor - licensee. Each party retains control of the day to day activities of its respective business.

Attachment A
To
Domino's Pizza Distribution LLC Pulse System License Agreement
Fees and charges applicable to each store licensed by this Agreement

Domino's Pulse Software (from Domino's Pizza Distribution LLC)
Software Presently Required to run with Pulse Purchased Through Domino's Pizza Distribution LLC. These third party products and vendors, and the costs associated with these products, may change during the term of this Agreement at the sole discretion of DPD, and License Holder agrees to accept such changes when implemented by DPD and when same or similar product(s) are in use in a majority of company-owned Stores.
<ul style="list-style-type: none"> o Microsoft License Fee Including MS Office o Mapping and Routing Software o File Sync o Anti-virus Software o Credit Card Processing Software o Security Software
The amounts listed on this Attachment do not include amounts charged by any of these third-party vendors for annual or periodic maintenance and enhancement of their products. The amounts for third party maintenance and enhancements will be billed to License Holder without markup to DPD or rebate to DPD.
Customer/Data Conversion or Accudata
The Pulse License Fee is \$4,200.00 per store
Annual Software Enhancement Fee (Payable as invoiced. The Annual Software Enhancement Fee is \$743.10 for 2024 and is subject to increase each year, and License Holder shall pay the fee as adjusted by these increases for current and prior years. See Attachment B for further description.
The annual anniversary for Billing the Annual Enhancement Fee is January 1st. The owner of record the day the invoices are generated by DPD will be responsible for the full amount of the full amount of the invoice regardless of the day the franchisee or licensee takes possession of the store.

Attachment B
To
Domino's Pulse Software License Agreement
Software Enhancement Agreement

1. Software Enhancement Services

11 Provided that License Holder is using the then current version of Software in use in the majority of domestic Domino's stores (version "N") or the immediately preceding version of Software ("N-1"), is current in paying all applicable Software Enhancement Fees and is not otherwise in default under this Agreement, DPD will provide License Holder with the following Software Enhancement Services:

(a) Enhancement and maintenance of Domino's Pulse and related store and internet-based technologies provided as components of Domino's Pulse ("Core Pulse Functionality") with the Domino's Pulse License Fee and Annual Software Enhancement Fee.

(b) DPD will continue to use reasonable efforts to correct any Software error, and will provide to License Holder any error corrections, enhancements and updates to the Software which are developed and published by DPD and made generally available to other licensees of the Software at no additional cost. Error corrections will remedy any documented failure of the Software to perform in substantial conformance with the then-applicable user documentation. Minor mistakes in the user documentation are not considered errors in the Software, and DPD may revise the user Documentation to correctly describe the intended operation.

2. Annual Software Enhancement Fees

21 No charge for the initial twelve (12) month period following the installation of the Software at the Store ("Installation Date"). License Holder shall pay the Annual Software Enhancement Fee as per Attachment A. This fee will be due and payable annually upon receipt of invoice.

22 DPD may increase the Annual Software Enhancement Fee not more than once each year with sixty (60) days prior written notice to the License Holder. The increases to the Annual Software Enhancement Fee may be reviewed by TAB. The amount of any such annual increase shall not exceed five percent (5%) of the previous year's Annual Software Enhancement Fee, unless the TAB approves a greater increase, but in any event no annual increase shall exceed ten percent (10%) of the previous year's Annual Software Enhancement Fee.

23 DPD may at its own discretion make quarterly payment plans available to License Holders.

24 License Holder shall only be liable for Annual Software Enhancement Fees during the term of this Agreement.

3. Other

31 Third party software and operating system software may carry its own maintenance, warranty, or enhancement fees. These third-party maintenance, warranty, or enhancement fees will be billed to License Holder without markup to DPD or rebate to DPD. Any updates that DPD requires for the Software to operate properly will be provided to License Holder at a cost not to exceed pre-vailing market rates without markup to DPD or rebate to DPD.

32 DPD reserves the right to charge a reasonable connectivity fee to deliver Software Enhancement Services to License Holders who do not have DSL connections and use a dialup connection that results in costs to DPD. License Holder agrees to pay any such connectivity fees upon receipt of invoice from DPD.

Attachment C

To

Domino's Pulse Software License Agreement Participation Agreement

This Participation Agreement is entered into by the party signing below ("you") for the benefit of MSLI, GP ("Microsoft") and shall be enforceable against you by Microsoft in accordance with its terms. You acknowledge that Microsoft and **Domino's Pizza Distribution LLC** and/or its affiliates (the "customer") are parties to Microsoft Select Enrollment, No. 6645248 (the "agreement"), under which you desire to sublicense certain Microsoft products. As used in this Participation Agreement, the term to "run" a product means to copy, install, use, access, display, run or otherwise interact with it. You acknowledge that your right to run a copy of any version of any product sublicensed under the agreement is governed by the applicable product use rights for the product and version licensed as of the date you first run that copy. Such product use rights will be made available to you by the customer, or by publication at a designated site on the World Wide Web, or by some other means. Microsoft does not transfer any ownership rights in any licensed product and it reserves all rights not expressly granted.

I. Acknowledgment and Agreement. You hereby acknowledge that you have received a copy of the product use rights applicable to the products acquired under the above-referenced agreement; you have read and understood the terms and conditions as they relate to your obligations; and you agree to be bound by such terms and conditions, as well as to the following provisions:

- a. **Restrictions on use.** You may not:
- o Separate the components of a product made up of multiple components by running them on different computers, by upgrading or downgrading them at different times, or by transferring them separately, except as otherwise provided in the product use rights;
 - o Rent, lease, lend or host products without the express written consent of Microsoft;
 - o Reverse engineer, de-compile or disassemble products, except to the extent expressly permitted by applicable law despite this limitation;
 - o Transfer licenses to, or sublicense, products to the U.S. Government.

You acknowledge that products licensed under the agreement are of US-origin. You agree to comply with all applicable international and national laws that apply to these products, including the U.S. Export Administration Regulations, as well as end-user, end-use and country destination restrictions issued by U.S. and other governments. For additional information on exporting Microsoft products, see <http://microsoft.com/exporting/>.

b. **Limited product warranty.** Microsoft warrants that each version of a commercial product will perform substantially in accordance with its user documentation. This warranty is valid for a period of 90 days from the date you first run a copy of the version. Any warranties imposed by law concerning the products are limited to the same 90-day period. This warranty does not apply to components of products which you are permitted to redistribute under applicable product use rights, or if failure of the product has resulted from accident, abuse or misapplication. If you notify Microsoft within the warranty period that a product does not meet this warranty, then Microsoft will, at its option, either (i) return the price paid for the product or (ii) repair or replace the product. This is your exclusive remedy for any failure of any commercial product to function as described in this paragraph.

c. **Free and beta products.** Free and beta products, if any, are provided "as-is," without any warranties.

d. **NO OTHER WARRANTIES.** TO THE EXTENT PERMITTED BY APPLICABLE LAW, MICROSOFT DISCLAIMS ALL WARRANTIES AND CONDITIONS, WHETHER EXPRESS, IMPLIED OR STATUTORY, OTHER THAN THOSE IDENTIFIED EXPRESSLY IN THIS SECTION, INCLUDING BUT NOT LIMITED TO WARRANTIES OR CONDITIONS OF TITLE, NON-INFRINGEMENT, MERCHANTABILITY AND FITNESS FOR A PARTICULAR PURPOSE, WITH RESPECT TO THE PRODUCTS AND RELATED MATERIALS.

e. **Limitation of liability.** There may be situations in which you have a right to claim damages or payment from Microsoft. Except as otherwise specifically provided in this paragraph, whatever the legal basis for your claim, Microsoft's liability will be limited, to the maximum extent permitted by applicable law, to direct damages up to the amount you have paid for the product giving rise to the claim. In the case of free product, or code you are authorized to redistribute to third parties without separate payment to Microsoft, Microsoft's total liability to you will not exceed US\$5000, or its equivalent in local currency.

f. **No liability for certain damages.** To the maximum extent permitted by applicable law, neither you, your affiliates or suppliers, nor Microsoft, its affiliates or suppliers will be liable for any indirect damages (including, without limitation, consequential, special or incidental damages, damages for loss of profits or revenues, business interruption, or loss of business information) arising in connection with any agreement, product or service, even if advised of the possibility of such damages or if such possibility was reasonably foreseeable.

g. **Application.** The limitations on and exclusions of liability for damages set forth herein apply regardless of whether the liability is based on breach of contract, tort (including negligence), strict liability, breach of warranties, or any other legal theory.

h. **Verifying compliance.** You must keep records relating to the products you run. Microsoft has the right to verify compliance with these terms and any applicable product use rights, at its expense, during the term of the agreement and for a period of one year thereafter. To do so, Microsoft will engage an independent accountant from a nationally recognized public accounting firm, which will be subject to a confidentiality obligation. Verification will take place upon not fewer than 15 days notice, during normal business hours and in a manner that does not interfere unreasonably with your operations. As an alternative, Microsoft may require you to accurately complete its self-audit questionnaire relating to the products you use. If verification or self-audit reveals unlicensed use of products, you must promptly order sufficient licenses to permit all product usage disclosed. If material unlicensed use is found (license shortage of 5% or more), you must reimburse Microsoft for the costs it has incurred in verification and acquire the necessary additional licenses as single retail licenses within 30 days. If Microsoft undertakes such verification and does not find material unlicensed use of products, it will not undertake another such verification for at least one year. Microsoft and its auditors will use the information obtained in compliance verification only to enforce its rights and to determine whether you are in compliance with these terms and the product use rights. By invoking the rights and procedures described above, Microsoft does not waive its rights to enforce these terms or the product use rights, or to protect its intellectual property by any other means permitted by law.

i. **Dispute Resolution; Applicable Law.** This Participation Agreement will be governed and construed in accordance with the laws of the jurisdiction whose law governs the agreement. You consent to the exclusive jurisdiction and venue of the state and federal courts located in such jurisdiction.

Your violation of the above-referenced terms and conditions shall be deemed to be a breach of this Participation Agreement and shall be grounds for immediate termination of all rights granted hereunder.

Dated as of the _____.

CUSTOMER AFFILIATE: «FranFormalName»

Signature: _ Name:

«FranFormalName»

Individually and as authorized representative
of each Owned Entity

FCode: F _____

Date: _____

EXHIBIT K

EXPIRATION OF FRANCHISE AGREEMENT AND RELEASE

**EXPIRATION OF FRANCHISE AGREEMENT
AND RELEASE**

THIS EXPIRATION OF FRANCHISE AGREEMENT AND RELEASE (the "Agreement") is made and entered into, effective on **(Date Franchise Agreement Expires)** between Domino's Pizza Franchising LLC, a Delaware limited liability company ("Franchisor") and «CorpName» and all of its shareholders, owners, partners, members, officers, directors, employees, agents, affiliates, subsidiaries, related entities, successors, heirs and assigns collectively ("Franchisee").

WITNESSETH:

WHEREAS, Franchisor and Franchisee previously entered into a franchise agreement dated «SFAExecutedDate» (the "Franchise Agreement") for Domino's Pizza Store #«StoreID», located at «StoreAddressLine» (the "Store"); and

WHEREAS, the Franchise Agreement expires on **(Date Franchise Agreement Expires)** and the Franchisee desires to exercise its option to renew the franchise under the Franchise Agreement by entering into a new franchise agreement which renewal is subject to the terms and conditions of this Agreement.

NOW, THEREFORE, in consideration of the covenants contained herein, and other good and valuable consideration, the receipt of which is hereby acknowledged, the parties hereto agree as follows:

1. Subject to the terms and conditions contained herein, the Franchise Agreement and all rights and obligations of the parties thereunder are hereby terminated and cancelled effective as of the expiration date of the Franchise Agreement, and shall be of no further force or effect.
2. Notwithstanding anything contained herein to the contrary, Franchisee agrees to be bound by and comply with all of the post-expiration obligations set forth in Section 18.3, 20.2 and 20.5 of the Franchise Agreement. In addition, all obligations of Franchisee to indemnify Franchisor, its subsidiaries and its affiliated companies and any of their agents and employees under the terms of Section 22.3 of the Franchise Agreement for, among other things, any and all claims arising out of the operation of the Store, and all obligations owed to the Franchisor, its subsidiaries and affiliated companies and their agents and employees arising out of relationships other than the franchise relationship (such as vendor purchaser or which arise out of a sales and security agreement or promissory note), shall survive notwithstanding the execution of this Agreement.
3. Franchisee, for itself and all natural and legal persons claiming by, through or under it, hereby releases Franchisor and its subsidiaries and affiliated companies and their respective officers, directors, agents, employees, members, affiliated companies, legal representatives, heirs and assigns from all obligations, claims, debts, demands, covenants, contracts, promises, agreements, liabilities, costs, attorney's fees, actions or causes of action whatsoever, whether known or unknown, which Franchisee had, has or claims to have against any or all of the parties described above as of the date hereof, arising out of, pursuant to, or related to the Franchise Agreement and the franchise relationship created thereby, including but not limited to, the offer, sale, negotiation, default, and/or

performance of the Franchise Agreement; provided, however, such releases shall not apply to any claims under state franchise laws to the extent prohibited by the provisions of any such laws.

4. This Agreement shall be binding in all respects upon the parties hereto and their respective shareholders, owners, partners, members, officers, directors, employees, agents, affiliates, subsidiaries, related entities, successors, heirs and assigns, and nothing contained herein shall release the parties from their obligations under this Agreement.
5. If any provision of this Agreement shall be held invalid by operation of law or by any court of competent jurisdiction, the remainder of this Agreement shall remain in full force and effect, and may be independently enforced to the fullest extent permitted by law.

The parties hereto have executed this Agreement.

FRANCHISEE: «CorpName»

«FranFormalName»
President

DOMINO'S PIZZA FRANCHISING LLC

By: _____
Colleen McCormick
Sr. Manager - Regulatory Affairs and Contracts

Dated: _____

EXHIBIT L

RIDER TO LEASE

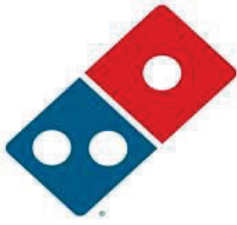

Domino's Pizza

FRANCHISE STORE LEASE POLICY

As of March 2022

Pursuant to Section 7.4 ("Store Lease") of the Domino's Pizza Franchise Agreement, you are required to maintain a lease for the site of the Store. Additionally, all proposed leases for new builds, re-franchises, relocations, or renewals are required to include the attached "RIDER TO LEASE" and be submitted to the Franchise Services Department for review and approval prior to execution.

A proposed lease for new builds, re-franchises, and relocations cannot be approved until the Franchise Services Department has an approved franchise application and an approved site inspection.

The "RIDER TO LEASE" requires the following provisions:

1. Inconsistency between Lease and Rider
2. Definitions
3. Use and Occupancy
4. Assignment of Lease
5. Notice of Default
6. Adequate Parking
7. Standard Signage
8. Adjoining Uses
9. Damage to Premises
10. De-Identification
11. Payment of Rent

Exception: *Percentage of Sales Rent included in Non-Traditional Store Leases will be reviewed on a case-by-case basis.*

NOTE: You must insert the Tenant and Landlord entities in the first paragraph and on the signature page of the "RIDER TO LEASE" consistent with the entities in the proposed lease. Additionally, the Store address must be inserted in the second paragraph of the "RIDER TO LEASE" consistent with the proposed lease.

Domino's Pizza LLC, as Manager, Domino's Pizza Franchising LLC or any of their affiliates are not liable for the final terms and provisions of any franchise lease. It is strongly advised that you work with a knowledgeable attorney or business advisor when negotiating the lease terms.

DOMINO'S PIZZA RIDER TO LEASE

THIS RIDER TO LEASE (the "Rider") is made this _____ day of _____, 20____, by and between _____
_____ ("Tenant") and _____ ("Landlord").

(Print "Tenant Name" & "Landlord Name" Above)

RECITALS

WHEREAS, concurrently with the execution of this Rider, Tenant, a franchisee of Domino's Pizza Franchising LLC ("DPF"), and Landlord have entered into a lease (the "Lease") for the premises of Tenant's Domino's Store located at:

_____ (the "Premises"); and

(Print "Complete Store Address" Above)

WHEREAS, as a condition to DPF's grant of a franchise to a franchisee, DPF requires that certain provisions be contained in the lease entered into by its franchisees to establish an alignment and approval of certain subjects and activities within the Franchise Agreement that the franchisee has signed, or will be signing, to operate the store covered by the Lease Agreement; and

WHEREAS, to evidence Landlord's and Tenant's agreement to these terms, the parties hereby enter this Rider to Lease;

NOW, THEREFORE, the parties agree as follows:

1. **Inconsistency between Lease and Rider.** In the event of any inconsistency between the terms of the Lease and this Rider, the terms of this Rider shall prevail.

2. **Definitions.** In this Rider, the following words or phrases will have the following meanings:

Domino's Pizza Franchising LLC "DPF" **Franchisor.**
Domino's subsidiary issuing franchise agreements to domestic franchisees within United States.

Domino's Pizza LLC "DPL"
Domino's subsidiary of which manages and oversees the primary operations of all Domino's subsidiaries and business.

Domino's Pizza LLC – Manager "DPL-M"
DPL as Manager for DPF providing required support and services to franchisees under their franchise agreements.

Franchise Agreement "FA"
The agreement between franchisor and franchisee allowing for the operation of the Domino's store at the leased premises.

Successor Tenant
The Domino's franchisee, or corporate entity, that purchases the Domino's store from the currently operating Tenant in accordance with terms set forth in this Rider.

3. **Use and Occupancy.** Tenant may only use the leased premises (the "Premises") as a quick service pizza restaurant for the preparation, consumption, dine-in, carry-out and delivery of pizza, sandwiches, salads, chicken items, pastas and related foods and beverages and those items customarily sold, either now or in the future, in a Domino's Store or other similar enterprise or establishment so long as such future use does not conflict with any applicable governmental laws, rules and regulations or any exclusive use granted prior to the date of this Lease to other tenants within the shopping center.

4. **Assignment of Lease.** Anything contained in the Lease to the contrary notwithstanding, Landlord agrees that the Lease and the right, title and interest of the Tenant and any subsequent or successor Tenant thereunder, shall be sold and assigned by Tenant, but only upon and with the sole authorization and management of DPF in accordance to the terms of the Tenant's FA with DPF, to Domino's Pizza LLC or to a Successor Tenant provided Landlord receives notice of such assignment, and further provided, that the assignee shall execute such documents evidencing its agreement to thereafter keep and perform, all of the obligations of Tenant arising under the Lease from and after the time of such assignment. Further, Successor Tenant shall have no responsibility for prior defaults under the Lease and Landlord shall not terminate the Lease upon assignment.

In addition, anything contained in the Lease to the contrary notwithstanding, Landlord agrees to allow a change in the controlling interest of the Tenant and any subsequent or successor Tenant thereunder, in the event such controlling owner is Domino's Pizza LLC or an approved franchisee of DPF, without the consent of Landlord, provided, however, that Landlord shall be provided notice of such change in controlling interest.

5. **Notice of Default.** Landlord shall give written notice to Domino's Pizza LLC, as Manager, Attn: Franchise Services Department (via email at franchise.services@dominos.com), (concurrently with the giving of such notice to Tenant), of any default by Tenant under the Lease and Domino's Pizza LLC may cure such default at its sole option within thirty (30) days receipt of said notice. Notice shall be sent via USPS mailing services to PO Box 485, Ann Arbor, MI 48105-0485, or via any overnight courier services requiring a street address to 24 Frank Lloyd Wright Drive, Suite F1200, Ann Arbor, MI 48105-9484.

6. **Adequate Parking.** Notwithstanding any parking provisions defined in the Lease, Landlord agrees that Tenant's active Retail Delivery Drivers will be exempt from any mandated "employee parking" designated by Landlord. Rather, the retail delivery drivers may be permitted to park as near or adjacent to the Premises as possible for the loading and unloading of their vehicles in service of Tenant's Delivery Customers. Drivers must not park in front of other tenant's spaces when the businesses are open. Tenant's in-store employees shall abide by any employee parking requirements defined in the Lease.

7. **Standard Signage.** It is requested that Tenant be permitted to install the customary and usual Domino's Pizza display signs (including pole-type or tenant-shared signs if they are permitted and/or available) on and adjacent to the Premises, subject to the conditions set forth in the Lease or any Lease Exhibits. Renderings of the signs, advertisements, notices, logos, lettering, standard images, and advertising practices of the Domino's Pizza LLC advertising program, are attached to this rider to provide general guidance of the Domino's signage program. Tenant shall be responsible for coordinating with a professional signage company for the actual signage design to be manufactured and installed upon the Premises once all approvals and permissions have been received.

8. **Adjoining Uses.** No operation currently exists, and Landlord shall not permit, directly or indirectly, another quick service pizza restaurant which sells pizza for delivery or carry out ("Competing Business") to be operated within the Shopping Center including out parcels and pad sites that is a direct competitor (including, but not limited to, Pizza Hut, Papa John's, Little Caesars and Papa's Pizza, (list other major regional competitors if applicable)). The aforementioned restriction shall not apply to: (i) any existing leases at the Shopping Center as the same may be renewed, extended, modified or amended (except that no such renewal, extension, modification or amendment shall grant a tenant the right to engage in the Exclusive Use where such tenant did not previously have that right), or (ii) any store measuring 5,000 sq. ft. or more; or (iii) a full service sit-down restaurant; or (iv) a buffet style pizza restaurant; or (v) any portion of the Shopping Center that is not owned by Landlord.

Should Landlord violate this provision, all rent shall abate in full until such time that the Competing Business no longer occupies space in the Shopping Center. Should the Competing Business remain open and in business for a period in excess of three hundred sixty-five (365) days Tenant may terminate the Lease forthwith with thirty (30) days written notice thereof delivered to Landlord.

9. **Damage to Premises.** In the event the Premises or any material portion thereof or any adjoining property

shall be damaged by fire or other casualty during the term hereof so as to render the Premises, including any common area, untenable, Landlord shall promptly restore the same to their previous condition, and a just proportion of the rent, according to the extent to which the Premises and any common areas have been rendered untenable, shall abate until the Premises shall have been restored and put in proper condition for use and occupancy by Tenant. However, per terms of tenant's FA with Franchisor that require that a closed store be re-opened within one hundred eighty (180) days of the casualty, if the damaged Premises cannot be made tenable within one hundred twenty (120) days after the occurrence of such damage, for reasons including, but not limited to, insurance issues, building and permitting issues and construction delays, Tenant may terminate this Lease forthwith upon thirty (30) days' written notice thereof delivered to Landlord and any rent paid in advance of such termination by Tenant shall forthwith be refunded to it. If any authority having jurisdiction thereof shall determine that the Premises or any building of which the Premises are a part should be demolished and removed because of damage, this Lease shall terminate within 30 days of receiving notice of same and any rent paid in advance of such determination by Tenant shall be refunded to it.

10. **De-identification.** Landlord acknowledges that Tenant is entering the Lease to operate a Domino's Pizza franchise, as an independent business entity. Tenant is required upon termination or expiration of the Lease, or upon termination or expiration of the Franchise Agreement, that Tenant shall, at Tenant's sole expense, and within ten (10) business days, make such reasonable modifications to the exterior and interior of the Leased Premises (including interior and exterior signage, menu boards, job aids, product photos, and the like) as is necessary or useful to fully eliminate all identification and appearance as a Domino's Store.

If Tenant fails or refuses to timely and fully de-identify the Leased Premises to the extent and in the time and manner required by the foregoing paragraph of this Rider to Lease, Domino's Pizza LLC may, at its sole option and in addition to other rights and remedies it may have, make said modifications on Tenant's behalf, so long as Domino's contacts Landlord prior to commencing any activity to do so, and both parties enter into a reasonable written agreement to be executed of the scope of work to be done, the timing and conditions related to said work, access to the Premises and indemnifications as needed. Whether it is Domino's or Landlord that ultimately does the de-identification of the space due to Tenant's failure to do so, all expenses incurred in the activity shall be the responsibility of the Tenant. The foregoing shall not give Landlord or any other entity additional rights to require the restoration or repair of the Leased Premises beyond that which is agreed to between Landlord and Tenant. Landlord acknowledges that Domino's Pizza LLC will not be required to make any repairs, restorations, or de-identifications of the Lease Premises unless it exercises its option to make said modifications.

11. **Payment of Rent.** Notwithstanding anything in the Lease to the contrary Tenant and Landlord acknowledge that Tenant's rent or lease obligations shall not be determined based upon Tenant's sales.

IN WITNESS, WHEREOF, the parties have executed this Rider on or as of the date first above written.

LANDLORD:

TENANT:

Print "Company Name" Above

Print "Company Name" Above

By: Signature

By: Signature

(Print "Name" Above)

(Print "Name" Above)

Its: *(Print "Title" Above)*

Its: *(Print "Title" Above)*

RIDER - Exhibit
Sign Examples for Pizza Theatre Restaurant Design

Domino's Pizza Theatre Signage / New Logo

DOMINO'S PIZZA THEATER CONSTRUCTION MANUAL - Q3 '20

ENTRYWAY GRAPHICS



- A. "Welcome" Customer Entry Door VinylPC 273243
- B. "Welcome" Glass Partition Wall Vinyl.....PC 273260
- D. "Now Serving - Open" LED Peel Sign.....PC 284050
 French "Now Serving - Open" SignPC 284051
- E. "Pick Up Window Open" LED Peel SignPC 284052
- F. LED Disk "Open" SignPC 284053

Typeface - Color Scheme - Domino's Word Mark

PRIMARY TYPEFACE

One Dot Bold Condensed

**AaBbCcDdEeFfGgHhIiJjKkLlMm
NnOoPpQqRrSsTtUuVvWwXxYyZz
1234567890**

PRIMARY COLORS



PANTONE colors should be used for any printed media where pantone swatches are specified



TRANSLUCENT VINYL colors should be used for illuminated signs, monument signs, and any other illumination is necessary.

**PRIMARY ORIENTATION
SPATIAL RELATIONSHIP**



ORIENTATION:
The tile logo must always appear at a 45° angle to the right.

SPATIAL RELATIONSHIP:
The tile logo should always have a safe area around it at least 100% the diameter of the white dot, or "pip", in the logo. This gives our logo room to breathe and helps them stand out. Height of inset of "o" = distance between type and tile. No Elements may be positioned within the protected zone.

Individual Front-Lit Channel Letters - Stacked (Size Chart)

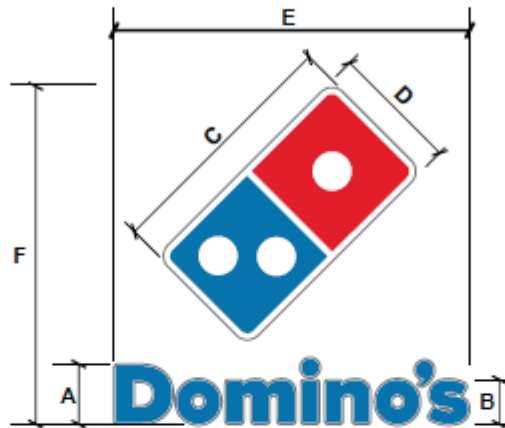

Boxed Sq. Ft.



Total Sq. Ft.

A	B	C	D	E	F	Boxed area logo & letters	Total Sq. Ft.
16"	11 $\frac{1}{8}$ "	65 $\frac{3}{4}$ "	34"	7'-10 $\frac{1}{2}$ "	7'-6 $\frac{1}{2}$ "	50.02	58.95
18"	13 $\frac{1}{2}$ "	73 $\frac{3}{4}$ "	38 $\frac{1}{4}$ "	8'-10 $\frac{1}{2}$ "	8'-5 $\frac{1}{2}$ "	54.48	74.61
20"	15"	82"	42 $\frac{1}{2}$ "	9'-10"	9'-5"	67.2	92.12
24"	18"	98 $\frac{1}{2}$ "	50 $\frac{3}{4}$ "	11'-10"	11'-3 $\frac{1}{2}$ "	96.77	132.63
30"	22"	123"	63 $\frac{1}{2}$ "	14'-9"	14'-1 $\frac{1}{2}$ "	151.21	207.24



Individual
Front-Lit Channel Letters
Stacked Size Chart



sales@indiesignage.com
(623) 302-4545

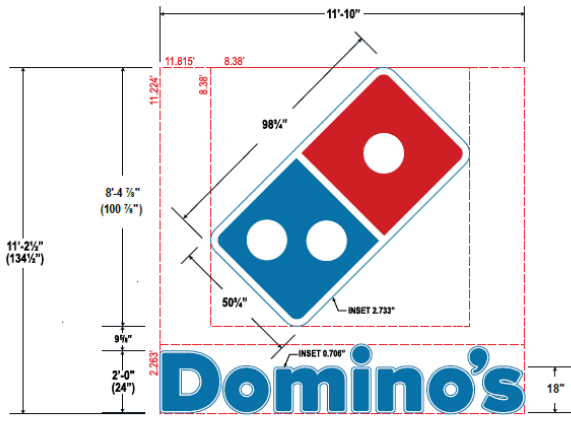

A Domino's Stacked Wordmark Channel 24" Blue QTY: ONE (1) SET
SCALE: 3/8"=1'-0" AREA: 132.61 SQ. FT.

Description -

Tile Logo:

Vinyl applied after routing
3/16" 7328 White Acrylic
3M Intense Blue 3730-127 (PMS 307C)
3M Red 3730-33 (PMS 186C)

Trimcap:

Jewellee White Trim cap bonded to face, #8 pan head screws to returns painted white, semigloss finish

Returns:

.040 Aluminum returns painted white, semigloss finish

Backs:

3mm ACM

LEDS :

Principal Qwik Mod 3 LED
Power Supply: Principal P-LED 12VDC

WM Channel Letters:

Vinyl applied after routing
Border - Exposed White Acrylic:
3/16" 7328 White Acrylic
3M Intense Blue 3730-127 (PMS 307C)

Trimcap:

Jewellee Trim cap bonded to face, #8 pan head screws to returns painted to match PMS 307 C Blue, semigloss finish.

Returns:

.040 Aluminum returns painted to match PMS 307 C Blue semigloss finish

Backs:

3mm ACM

LEDS :

Principal Qwik Mod 3 LED
Power Supply: Principal P-LED 12VDC

Tile Logo.....70.22 SQ. FT.
WM Letter Set.....26.74 SQ. FT.
Total.....96.96 SQ. FT.

Boxed.....132.61 SQ. FT.
Total.....132.61 SQ. FT.

3730-127 3M INTENSE BLUE TRANSLUCENT
3730-33 3M RED TRANSLUCENT



1 LED Layout

Specifications: Principle Quik Mod 3 LEDs

Beam Angle 170° Ultra-Wide Low Dome Batching Optic with Diamondback Optic Lens Technology
Certifications UL & cUL Recognized (SAM Manual), CE, RoHS, CSA
Dimensions QM3: 0.69"W x 3.14"L x 0.25"H
Fastening Peel & stick / Mechanical screw hole
Input 12VDC, Power Supply P-LED 12VDC
Protection Grade IP68
Spacing QM3: 1.5 mods/ft. (fully stretched)
Quantity: One Hundred and Thirteen (113) units

Electrical Detail:

White LEDs
(1) 60w Transformer GEPS12-60U-NA
Total Amps: 0.60
(1) 20 amp 120V Circuit Req.



General Notes:

This sign is to be installed in accordance with the requirements of Article 600 of the National Electrical Code.

- 1) Grounded and bonded per NEC 600.7NEC 250
 - 2) Existing branch circuit in compliance with NEC 600.5, not to exceed 20 amps
 - 3) Sign is to be UL listed per NEC 600.3
 - 4) UL disconnect switch per NEC 600.6 required per sign component before leaving manufacturer*
- *For multiple signs, a disconnect is permitted but not required for each section

Design Note:

This sign must only be scaled in its entirety it is forbidden to scale JUST the tile or JUST the wordmark by themselves

SIGN A	Domino's Stacked Wordmark Channel 24" Blue
Type:	Individual Channel Letters/Remote
Illumination:	Internally Illuminated LED
Square Footage:	157.47
To Grade:	Top of Sign to Grade Bottom of Sign to Grade*

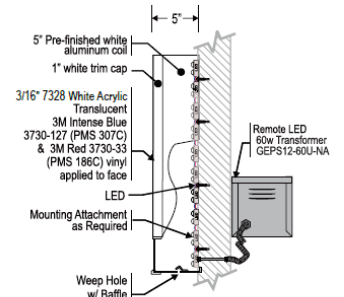

2 Channel Logo Side View

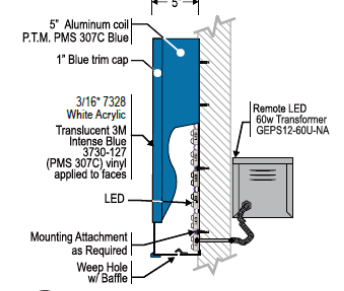

3 Channel Letter Side View



Sign_Channel_Stacked WM Blue 24

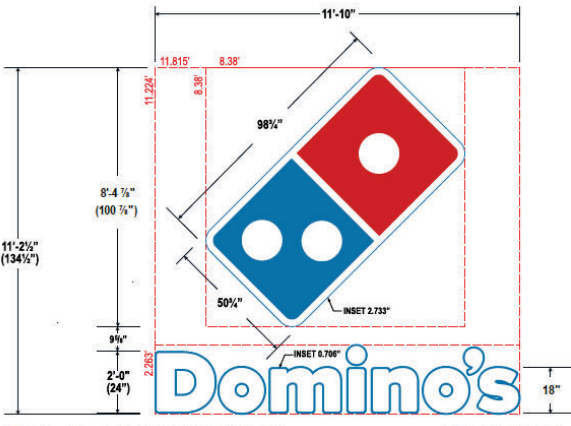

A Sign Channel Stacked WM White 24" QTY: ONE (1) SET
SCALE: 3/8"=1'-0" AREA: 132.61 SQ. FT.

Description -

Tile Logo:

Vinyl applied after routing
3/16" 7328 White Acrylic
3M Intense Blue 3730-127 (PMS 307C)
3M Red 3730-33 (PMS 186C)

Trimcap:

Jewellee White Trim cap bonded to face, #8 pan head screws to returns painted white, semigloss finish

Returns:

.040 Aluminum returns painted white, semigloss finish

Backs:

3mm ACM

LEDS :

Principal Qwik Mod 3 LED
Power Supply: Principal P-LED 12VDC

WM Channel Letters:

Vinyl applied after routing
Border - Exposed White Acrylic:
3/16" 7328 White Acrylic
3M Intense Blue 3730-127 (PMS 307C)

Trimcap:

Jewellee Trim cap bonded to face, #8 pan head screws to returns painted to match PMS 307 C Blue, semigloss finish.

Returns:

.040 Aluminum returns painted to match PMS 307 C Blue semigloss finish

Backs:

3mm ACM

LEDS :

Principal Qwik Mod 3 LED
Power Supply: Principal P-LED 12VDC

Tile Logo.....70.22 SQ. FT.
WM Letter Set.....26.74 SQ. FT.
Total.....96.96 SQ. FT.

Boxed.....132.61 SQ. FT.
Total.....132.61 SQ. FT.

3730-127 3M INTENSE BLUE TRANSLUCENT
3730-33 3M RED TRANSLUCENT

1 LED Layout

Specifications: Principle Quik Mod 3 LEDs

Beam Angle 170° Ultra-Wide Low Dome Batching Optic with Diamondback Optic Lens Technology
Certifications UL & cUL Recognized (SAM Manual), CE, RoHS, CSA
Dimensions QM3: 0.69"W x 3.14"L x 0.25"H
Fastening Peel & stick / Mechanical screw hole
Input 12VDC, Power Supply P-LED 12VDC
Protection Grade IP68
Spacing QM3: 1.5 mods/ft. (fully stretched)
Quantity: One Hundred and Thirteen (113) units

Electrical Detail:

White LEDs
(1) 60w Transformer GEPS12-60U-NA
Total Amps: 0.60
(1) 20 amp 120V Circuit Req.



General Notes:

This sign is to be installed in accordance with the requirements of Article 600 of the National Electrical Code.

- 1) Grounded and bonded per NEC 600.7NEC 250
 - 2) Existing branch circuit in compliance with NEC 600.5, not to exceed 20 amps
 - 3) Sign is to be UL listed per NEC 600.3
 - 4) UL disconnect switch per NEC 600.6 required per sign component before leaving manufacturer*
- *For multiple signs, a disconnect is permitted but not required for each section

Design Note:

This sign must only be scaled in its entirety it is forbidden to scale JUST the tile or JUST the wordmark by themselves

SIGN A	Domino's Stacked Wordmark Channel 24" White
Type:	Individual Channel Letters/Remote
Illumination:	Internally Illuminated LED
Square Footage:	157.47
To Grade:	Top of Sign to Grade Bottom of Sign to Grade*

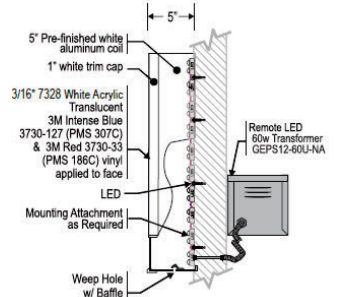

2 Channel Logo Side View

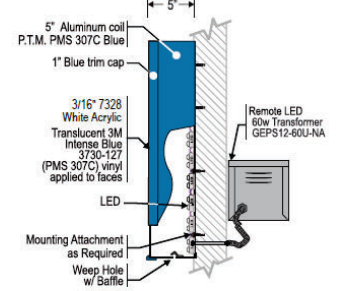

3 Channel Letter Side View



Sign_Channel_Stacked WM White 24

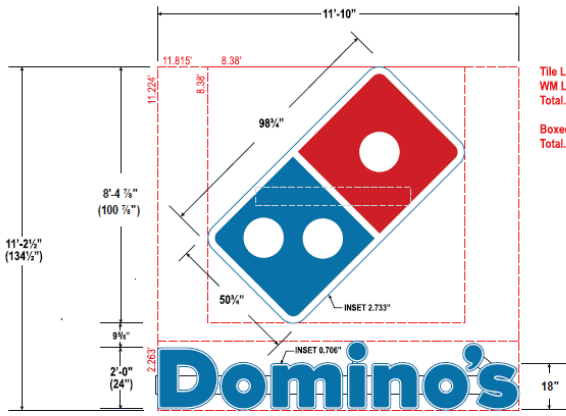

Tile Logo.....70.22 SQ. FT.
 WM Letter Set...26.74 SQ. FT.
 Total.....96.96 SQ. FT.

Boxed.....132.61 SQ. FT.
 Total.....132.61 SQ. FT.



1 LED Layout

SIGN A	Domino's Stacked Wordmark Channel_24" Blue
Type:	Individual Channel Letters/Raceway
Illumination:	Internally Illuminated LED
Square Footage:	137.47
To Grade:	Top of Sign to Grade Bottom of Sign to Grade

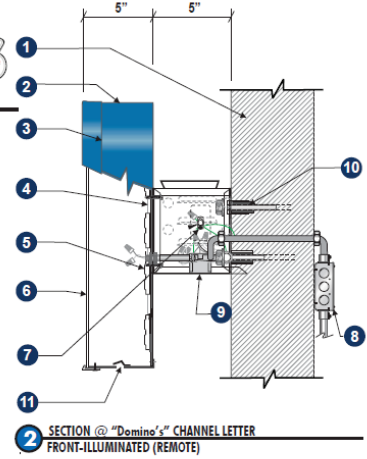

2 SECTION @ "Domino's" CHANNEL LETTER
 FRONT-ILLUMINATED (REMOTE)

Electrical Detail:
White LED's (1) 60w Transformer GEP512-60U-NA Total Amps: 0.60 (1) 20 amp 120V Circuit Req.
General Notes:
This sign is to be installed in accordance with the requirements of Article 600 of the National Electrical Code. 1) Grounded and bonded per NEC 600.7(N)EC-250 2) Existing branch circuit in compliance with NEC 600.5, not to exceed 20 amps 3) Sign is to be UL listed per NEC 600.3 4) UL disconnect switch per NEC 600.6- required per sign component before leaving manufacturer *For multiple signs, a disconnect is permitted but not required for each section
Raceway Note:
The raceway color should match, as closely as possible the building color and finish behind. When not possible a variance is required.
Design Note:
This sign must only be scaled in its entirety. It is forbidden to scale JUST the tile or JUST the wordmark by themselves.

Specifications: Principle Gwh Mod 3 LEDs
Beam Angle 170° Ultra-Wide Low Dome Baiting Optic with Diamondback Optic Lens Technology Certifications: UL & cUL Recognized (SAM Manual), CE, RoHS, CSA Dimensions QMS: 0.69"W x 3.14"L x 0.25"H Fastening Peel & stick / Mechanical screw hole Input: 12VDC, Power Supply P-LED 12VDC Protection Grade IP68 Spacing QMS: 1.5 moduft. (fully stretched) Quantity: One hundred thirteen (113) units

Specifications: Channel Letter & Logo Set
1. Existing Facade: TBD 2. 60/4 Aluminum returns painted PMS 307 C Blue for letters and White for logo. Semigloss finish. 3. Jewelle trimcap bonded to face, #8 pan head screws to returns painted to match PMS 307 C Blue for letters and White for logo 4. 3mm Signboard Lite composite backings fastened to returns w/ 1/4" 18 gauge staples. Seal w/ VOC compliant 360 white latex caulk to prevent moisture intrusion. 5. Principal Gwh Mod 3 White LEDs 6. 3/16" White acrylic faces w/ translucent vinyl applied to faces 7. 3M 3730-127 Intense Blue (for logo and Wordmark border) 8. 3M 3730-33 Red (for Logo) 9. 3M blackout white for "O" centers 10. Disconnected switch UL Outdoor rated toggle type w/ neoprene boot per NEC 600-6 11. Primary electrical feed in UL conduit / customer supplied UL junction box 12. Transformers within UL enclosure (removable lid), 5"x5" Raceway paint to match fascia 13. Mounting hardware to suit. 14. 1/2" Drain holes w/ light baffles at bottom of letter cans (2) per letter

safes@indiesignage.com
 (623) 302-4545



Sign_Channel_Stacked WM Blue Raceway 24

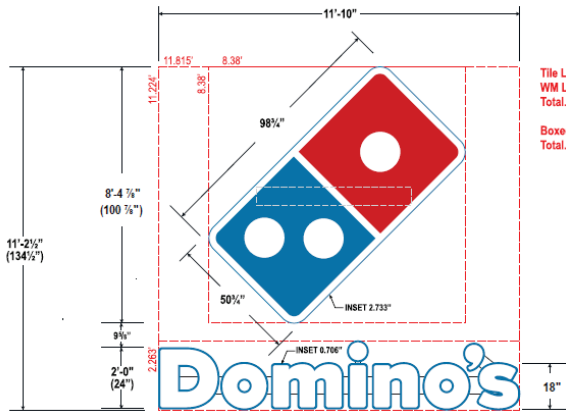

Tile Logo.....70.22 SQ. FT.
 WM Letter Set...26.74 SQ. FT.
 Total.....96.96 SQ. FT.

Boxed.....132.61 SQ. FT.
 Total.....132.61 SQ. FT.



1 LED Layout

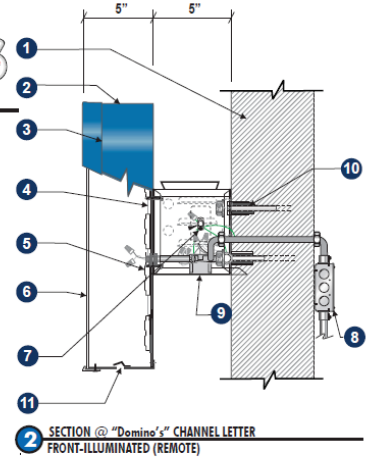

2 SECTION @ "Domino's" CHANNEL LETTER
 FRONT-ILLUMINATED (REMOTE)

Electrical Detail:
White LED's (1) 60w Transformer GEP512-60U-NA Total Amps: 0.60 (1) 20 amp 120V Circuit Req.
General Notes:
This sign is to be installed in accordance with the requirements of Article 600 of the National Electrical Code. 1) Grounded and bonded per NEC 600.7(N)EC-250 2) Existing branch circuit in compliance with NEC 600.5, not to exceed 20 amps 3) Sign is to be UL listed per NEC 600.3 4) UL disconnect switch per NEC 600.6- required per sign component before leaving manufacturer *For multiple signs, a disconnect is permitted but not required for each section
Raceway Note:
The raceway color should match, as closely as possible the building color and finish behind. When not possible a variance is required.
Design Note:
This sign must only be scaled in its entirety. It is forbidden to scale JUST the tile or JUST the wordmark by themselves.

Specifications: Principle Gwh Mod 3 LEDs
Beam Angle 170° Ultra-Wide Low Dome Baiting Optic with Diamondback Optic Lens Technology Certifications: UL & cUL Recognized (SAM Manual), CE, RoHS, CSA Dimensions QMS: 0.69"W x 3.14"L x 0.25"H Fastening Peel & stick / Mechanical screw hole Input: 12VDC, Power Supply P-LED 12VDC Protection Grade IP68 Spacing QMS: 1.5 moduft. (fully stretched) Quantity: One hundred thirteen (113) units

Specifications: Channel Letter & Logo Set
1. Existing Facade: TBD 2. 60/4 Aluminum returns painted PMS 307 C Blue for letters and White for logo. Semigloss finish. 3. Jewelle trimcap bonded to face, #8 pan head screws to returns painted to match PMS 307 C Blue for letters and White for logo 4. 3mm Signboard Lite composite backings fastened to returns w/ 1/4" 18 gauge staples. Seal w/ VOC compliant 360 white latex caulk to prevent moisture intrusion. 5. Principal Gwh Mod 3 White LEDs 6. 3/16" White acrylic faces w/ translucent vinyl applied to faces 7. 3M 3730-127 Intense Blue (for logo and Wordmark border) 8. 3M 3730-33 Red (for Logo) 9. 3M blackout white for "O" centers 10. Disconnected switch UL Outdoor rated toggle type w/ neoprene boot per NEC 600-6 11. Primary electrical feed in UL conduit / customer supplied UL junction box 12. Transformers within UL enclosure (removable lid), 5"x5" Raceway paint to match fascia 13. Mounting hardware to suit. 14. 1/2" Drain holes w/ light baffles at bottom of letter cans (2) per letter

safes@indiesignage.com
 (623) 302-4545



Sign_Channel_Stacked WM White Raceway 24

Front Lit Channel Tile Logo Size Chart

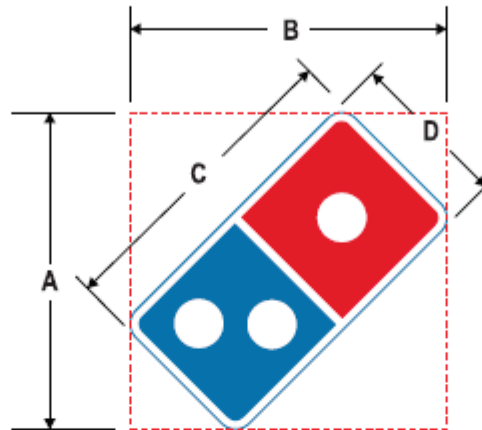
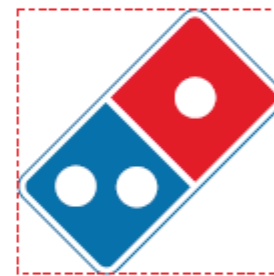

Footprint Area, Sq. Ft.

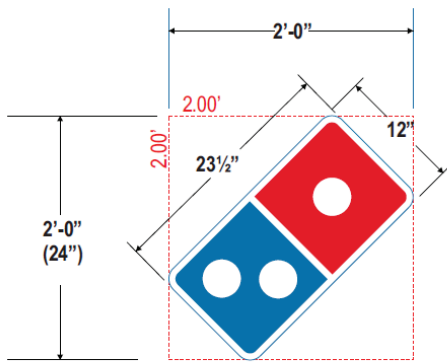
Total Area, Sq. Ft.

A	B	C	D	Footprint SQ.FT.	Total SQ.FT.
18"	18"	17¾"	9"	1.10	2.25
24"	24"	23½"	12"	2.48	4.00
30"	30"	29½"	15¼"	3.12	6.25
48"	48"	47¼"	24¼"	7.95	16.00

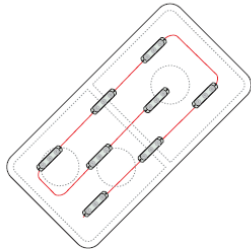

A Domino's Tile Logo 24" QTY: ONE (1)
SCALE: 1 1/2" = 1'-0" AREA: 4.0 SQ. FT.

SIGN AREA
LOGO (ACTUAL) 1.968 SQ. FT.
BOXED: 4.0 SQ. FT.



1 LED PATTERN
SCALE: 1 1/2" = 1'-0"

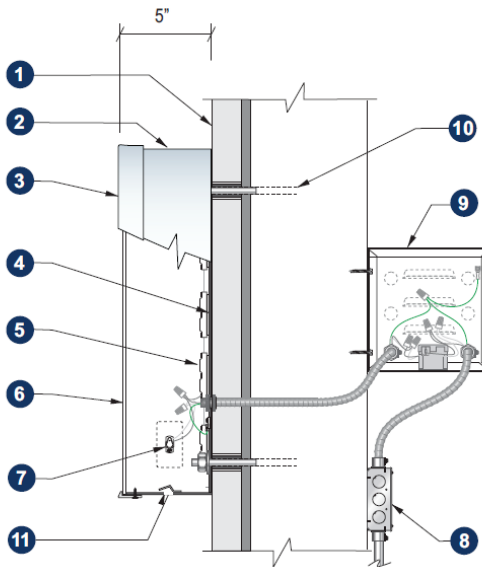

2 Section @ LED Channel Logo
Front-Lit (Remote)

SIGNA	Domino's 24" Logo
Type:	Channel Plaque
Illumination:	Internally Illuminated LED
Square Footage:	4.00
To Grade:	Top of Sign to Grade = Bottom of Sign to Grade =

Electrical Detail:
White LEDs
(1) 60w Transformer GEPS12-60U-NA
Total Amps: 0.60
(1) 20 amp 120V Circuit Req.

General Notes:
This sign is to be installed in accordance with the requirements of Article 600 of the National Electrical Code.

- 1) Grounded and bonded per NEC 600.7/NEC 250
- 2) Existing branch circuit in compliance with NEC 600.5, not to exceed 20 amps
- 3) Sign is to be UL listed per NEC 600.3
- 4) UL disconnect switch per NEC 600.6 required per sign component before leaving manufacturer

Specifications: Channel Letter & Logo Set

1. Existing Facade: TBD
2. .040 Aluminum returns painted White for: Semigloss finish.
3. Jewelle's trimcap bonded to face, #8 pan head screws to returns, painted semigloss White
4. 3mm Signabond Lite composite backs fastened to returns with 12" 18 gauge staples. Seal with VOC compliant 360 white latex caulk to prevent moisture intrusion.
5. Principal Quik Mod 3 White LEDs
6. 3/16" White acrylic faces w/ translucent vinyl applied to faces
 - 3M 3730-127 Intense Blue
 - 3M 3730-33 Red (for Logo)
 - 3M blackout white for "S" centers
7. Disconnect switch UL Outdoor rated toggle type w/ neoprene boot per NEC 600-6
8. Primary electrical feed in UL conduit / customer supplied UL junction box
9. Transformer within UL enclosure (removable lid), 1/4" x 1" min screws
10. Mounting hardware to suit
11. 1/2" Drain hole w/ light baffles at bottom of logo can (outdoor only)

Specifications: Principle Quik Mod 3 LEDs

Beam Angle 170° Ultra-Wide Low Dome Batwing Optic with Diamondback Optic Lens Technology
Certifications UL & cUL Recognized (SAM Manual), CE, RoHS, CSA
Dimensions QM3: 0.69"W x 3.14"L x 0.25"H
Fastening Peel & stick / Mechanical screw hole
Input 12VDC, Power Supply P-LED 12VDC
Protection Grade IP68
Spacing QM3: 1.5 mods/ft. (fully stretched)
Quantity: Eight (8) units

Domino's Tile Logo_24"



sales@indiesignage.com
(623) 302-4545

17

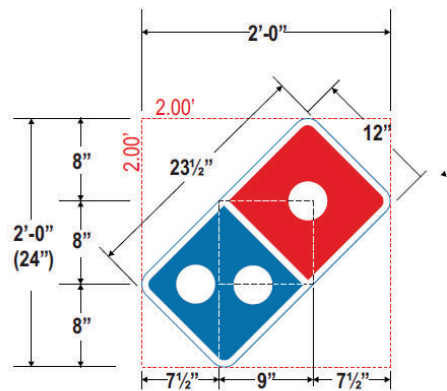

A Domino's Tile Logo Raceway 24" QTY: ONE (1)
SCALE: 1 1/2" = 1'-0" AREA: 4.0 SQ. FT.

SIGN AREA
LOGO (ACTUAL) 1.968 SQ. FT.
BOXED: 4.0 SQ. FT.

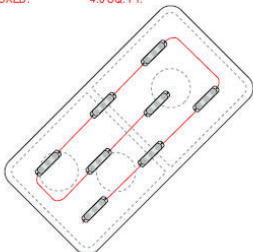

1 LED PATTERN
SCALE: 1 1/2" = 1'-0"

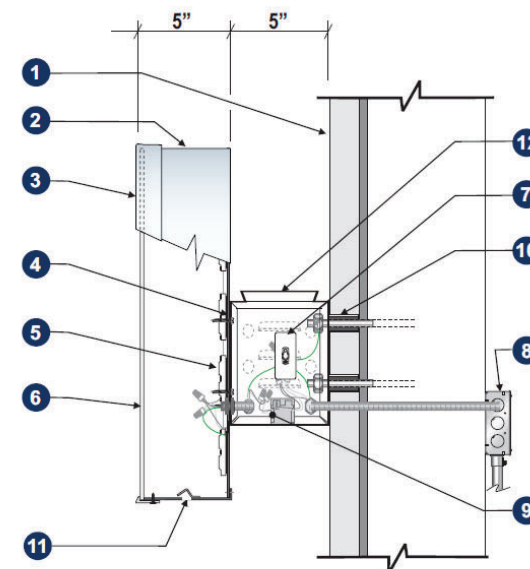

2 Section @ LED Channel Logo w/ Raceway
Front-Lit (Remote)

SIGNA	Domino's 24" Logo with Raceway
Type:	Channel Plaque
Illumination:	Internally Illuminated LED
Square Footage:	4.00
To Grade:	Top of Sign to Grade = Bottom of Sign to Grade =

Electrical Detail:
White LEDs
(1) 60w Transformer GEPS12-60U-NA
Total Amps: 0.60
(1) 20 amp 120V Circuit Req.

General Notes:
This sign is to be installed in accordance with the requirements of Article 600 of the National Electrical Code.

- 1) Grounded and bonded per NEC 600.7/NEC 250
- 2) Existing branch circuit in compliance with NEC 600.5, not to exceed 20 amps
- 3) Sign is to be UL listed per NEC 600.3
- 4) UL disconnect switch per NEC 600.6 required per sign component before leaving manufacturer

Specifications: Channel Letter & Logo Set

1. Existing Facade: TBD
2. .040 Aluminum returns painted White with Semigloss finish.
3. White Jewelle's trimcap bonded to face, #8 pan head screws to returns.
4. 3mm Signabond Lite composite backs fastened to returns with 12" 18 gauge staples. Seal with VOC compliant 360 white latex caulk to prevent moisture intrusion.
5. Principal Quik Mod 3 White LEDs
6. 3/16" White acrylic faces w/ translucent vinyl applied to faces
 - 3M 3730-127 Intense Blue
 - 3M 3730-33 Red (for Logo)
 - 3M blackout white for "S" centers
7. Disconnect switch UL Outdoor rated toggle type w/ neoprene boot per NEC 600-6
8. Primary electrical feed in UL conduit / customer supplied UL junction box
9. Transformer inside raceway
10. Mounting hardware to suit
11. 1/2" Drain hole w/ light baffles at bottom of logo can (outdoor only)

Specifications: Principle Quik Mod 3 LEDs

Beam Angle 170° Ultra-Wide Low Dome Batwing Optic with Diamondback Optic Lens Technology
Certifications UL & cUL Recognized (SAM Manual), CE, RoHS, CSA
Dimensions QM3: 0.69"W x 3.14"L x 0.25"H
Fastening Peel & stick / Mechanical screw hole
Input 12VDC, Power Supply P-LED 12VDC
Protection Grade IP68
Spacing QM3: 1.5 mods/ft. (fully stretched)
Quantity: Eight (8) units

Domino's Tile Logo Raceway_24"



sales@indiesignage.com
(623) 302-4545

18

Individual Front-Lit Channel Letters Linear Size Chart

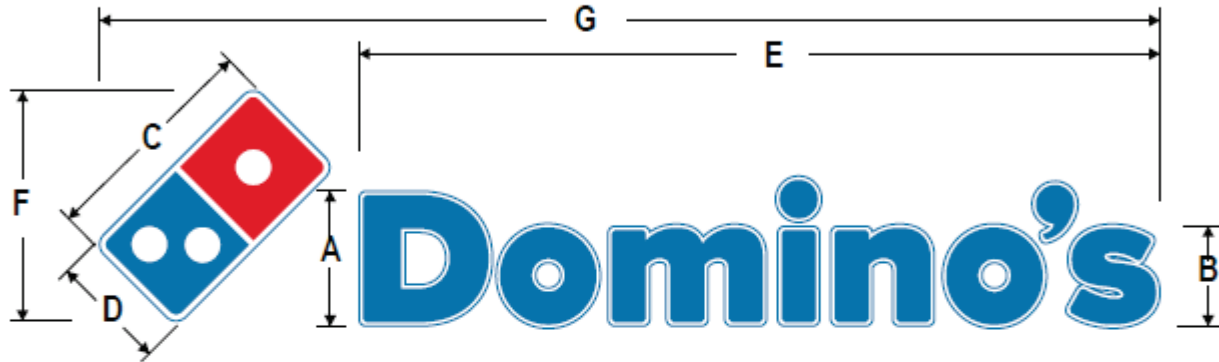

Boxed Sq. Ft.



Total Sq. Ft.

A	B	C	D	E	F	G	Boxed area logo & letters	Total Sq. Ft.
16"	12"	26 ³ / ₄ "	13 ³ / ₄ "	7'-11"	2'-3 ¹ / ₄ "	10'-5 ¹ / ₂ "	16.57	21.27
18"	13 ¹ / ₂ "	30"	15 ¹ / ₂ "	8'-11"	2'-6 ¹ / ₂ "	11'-9 ¹ / ₂ "	21.64	31.13
20"	15"	33 ¹ / ₂ "	17 ¹ / ₄ "	9'-10 ¹ / ₂ "	2'-10"	13'-1"	26.71	38.43
24"	18"	40"	20 ³ / ₄ "	11'-10"	3'-5"	15'-8 ¹ / ₂ "	38.53	55.34
30"	22"	50"	25 ³ / ₄ "	14'-10"	4'-3"	19-7 ¹ / ₂ "	60.1	86.47



Individual
Front-Lit Channel Letters
Linear Size Chart



sales@indiesignage.com
(623) 302-4545

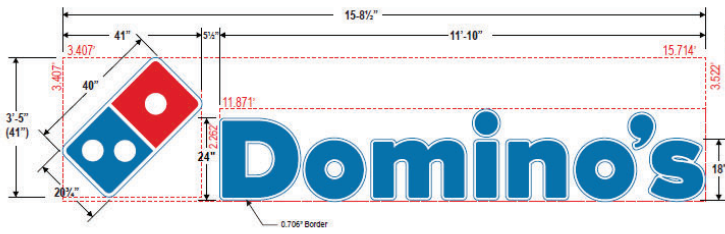

SIGN AREA
BOXED LOG & LETTERS: 38.53 SQ. FT.
SINGLE BOX: 55.34 SQ. FT.

SIGNA	
Type:	Domino's Horizontal Wordmark Channel_24" Blue
Individual Channel Letters:	
Illumination:	Internally Illuminated LED
Square Footage:	53.67
To Grade:	Top of Sign to Grade = Bottom of Sign to Grade =



1 LETTER DETAILS

A Domino's Horizontal Wordmark Channel 24" Blue QTY: ONE (1) SET
SCALE: 1/2" = 1'-0" AREA: 55.34 SQ. FT.

Electrical Detail:	
White LEDs	
(1) 60w Transformer GEPS12-60U-NA	
Total Amps: 0.60	
(1) 20 amp 120V Circuit Req.	

Specifications: Channel Letter & Logo Set	
1. Existing Facade: TBD	
2. .040 Aluminum returns painted PMS 307 C Blue for letters and White for logo. Semigloss finish.	
3. Jewelle trimcap bonded to face, #6 pan head screws to returns painted to match PMS 307 C Blue for letters and White for logo	
4. 3mm Signabond Lite composite backs fastened to returns w/ 1/2" 18 gauge staples. Seal w/ VOC compliant 380 white latex caulk to prevent moisture intrusion.	
5. Principal Qwik Mod 3 White LEDs	
6. 3/16" White acrylic faces w/ translucent vinyl applied to faces	
■ 3M 3730-127 Intense Blue	
■ 3M 3730-33 Red (for Logo)	
□ 3M blackout white for "S" centers	
7. Disconnect switch UL Outdoor rated toggle type w/ neoprene boot per NEC 600-6	
8. Primary electrical feed in UL conduit / customer supplied UL junction box	
9. Transformers within UL enclosure (removable lid), 1/4" x 1" min screws	
10. Mounting hardware to suit.	
11. 1/4" Drain holes w/ light baffles at bottom of letter cans (2) per letter	

General Notes:	
This sign is to be installed in accordance with the requirements of Article 600 of the National Electrical Code.	
1) Grounded and bonded per NEC 600.7/NEC 250	
2) Existing branch circuit in compliance with NEC 600.5, not to exceed 20 amps	
3) Sign is to be UL listed per NEC 600.3	
4) UL disconnect switch per NEC 600.6- required per sign component before leaving manufacturer* *For multiple signs, a disconnect is permitted but not required for each section	



2 LED PATTERN
SCALE: 1/2" = 1'-0"

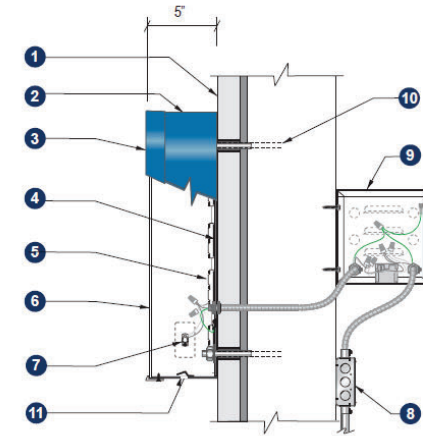

3 Section @ LED Channel Letter
Front-Lit (Remote)



Domino's Horizontal Wordmark Channel_24" Blue



sales@indiesignage.com
(623) 302-4545

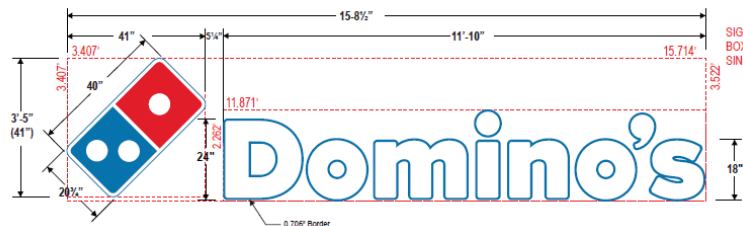

SIGN AREA
BOXED LOG & LETTERS: 38.53 SQ. FT.
SINGLE BOX: 55.34 SQ. FT.

SIGNA	
Type:	Dom Horiz WM Channel_24" White
Individual Channel Letters:	
Illumination:	Internally Illuminated LED
Square Footage:	53.67
To Grade:	Top of Sign to Grade = Bottom of Sign to Grade =



1 LETTER DETAILS

A Domino's Horizontal Wordmark Channel 24" White QTY: ONE (1) SET
SCALE: 1/2" = 1'-0" AREA: 53.34 SQ. FT.

Electrical Detail:	
White LEDs	
(1) 60w Transformer GEPS12-60U-NA	
Total Amps: 0.60	
(1) 20 amp 120V Circuit Req.	

Specifications: Channel Letter & Logo Set	
1. Existing Facade: TBD	
2. .040 Aluminum returns painted PMS 307 C Blue for letters and White for logo. Semigloss finish.	
3. Jewelle trimcap bonded to face, #6 pan head screws to returns painted to match PMS 307 C Blue for letters and White for logo	
4. 3mm Signabond Lite composite backs fastened to returns w/ 1/2" 18 gauge staples. Seal w/ VOC compliant 380 white latex caulk to prevent moisture intrusion.	
5. Principal Qwik Mod 3 White LEDs	
6. 3/16" White acrylic faces w/ translucent blue vinyl border applied to faces	
■ 3M 3730-127 Intense Blue	
■ 3M 3730-33 Red (for Logo)	
□ 3M blackout white for "S" centers	
7. Disconnect switch UL Outdoor rated toggle type w/ neoprene boot per NEC 600-6	
8. Primary electrical feed in UL conduit / customer supplied UL junction box	
9. Transformers within UL enclosure (removable lid), 1/4" x 1" min screws	
10. Mounting hardware to suit.	
11. 1/4" Drain holes w/ light baffles at bottom of letter cans (2) per letter	

General Notes:	
This sign is to be installed in accordance with the requirements of Article 600 of the National Electrical Code.	
1) Grounded and bonded per NEC 600.7/NEC 250	
2) Existing branch circuit in compliance with NEC 600.5, not to exceed 20 amps	
3) Sign is to be UL listed per NEC 600.3	
4) UL disconnect switch per NEC 600.6- required per sign component before leaving manufacturer* *For multiple signs, a disconnect is permitted but not required for each section	

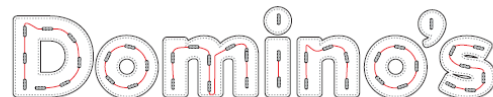
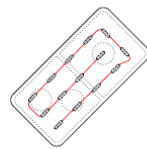

2 LED PATTERN
SCALE: 1/2" = 1'-0"

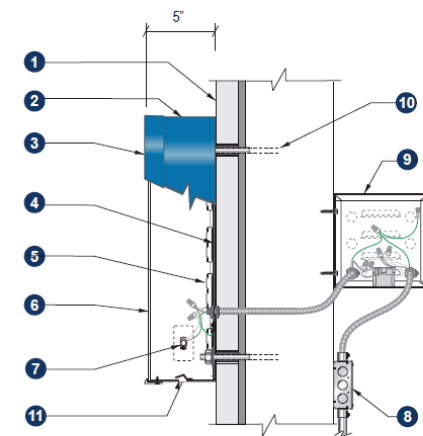

3 Section @ LED Channel Letter
Front-Lit (Remote)



Domino's Horizontal Wordmark Channel_24" White



sales@indiesignage.com
(623) 302-4545

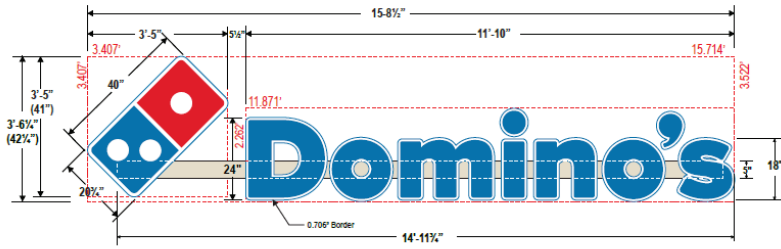

SIGN AREA
BOXED LOG & LETTERS: 38.53 SQ. FT.
SINGLE BOX: 55.34 SQ. FT.

SIGNA	
Type:	Domino's Horizontal Wordmark Channel-Raceway_24\" Blue
Individual Channel Letters w/ Raceway	
Illumination:	Internally Illuminated LED
Square Footage:	53.87
To Grade:	Top of Sign to Grade = Bottom of Sign to Grade =



A Dom Horiz WM Channel-Raceway 24\" Blue QTY: ONE (1) SET
SCALE: 1/2\" = 1'-0\" AREA: 55.34 SQ. FT.

Electrical Detail:	
White LEDs	
(1) 80w Transformer GEPS12-80U-NA	
Total Amps: 0.60	
(1) 20 amp 120V Circuit Req.	

Specifications: Channel Letter & Logo Set

- Existing Facade: TBD
- 040 Aluminum returns painted PMS 307 C Blue for letters and White for logo. Semigloss finish.
- Jewellee trimcap bonded to face, #6 pan head screws to returns painted to match PMS 307 C Blue for letters and White for logo
- 3mm Signabond Lite composite backs fastened to returns w/ 1/2\" 18 gauge staples. Seal w/ VOC compliant 360 white latex caulk to prevent moisture intrusion.
- Principal Qwik Mod 3 White LEDs
- 3/16\" White acrylic faces w/ translucent vinyl applied to faces
- 3M 3730-127 Intense Blue
- 3M 3730-33 Red (for Logo)
- 3M blackout white for \"S\" centers
- Disconnect switch UL Outdoor rated toggle type w/ neoprene boot per NEC 600-6
- Primary electrical feed in UL conduit / customer supplied UL junction box
- Transformers within UL enclosure (removable lid), 5\"x5\" Raceway, paint to match fascia
- Mounting hardware to suit.
- 1/4\" Drain holes w/ light baffles at bottom of letter cans (2) per letter

Specifications: Principle Qwik Mod 3 LEDs

Beam Angle 170° Ultra-Wide Low Dome Batwing Optic with Diamondback Optic Lens Technology
Certifications UL & cUL Recognized (SAM Manual), CE, RoHS, CSA
Dimensions QM3: 0.60\"W x 3.14\"L x 0.25\"H
Fastening Peel & stick / Mechanical screw hole
Input 12VDC, Power Supply P-LED 12VDC
Protection Grade IP68
Spacing QM3: 1.5 mods/ft. (fully stretched)
Quantity: Fifty-five (55) units

General Notes:
This sign is to be installed in accordance with the requirements of Article 600 of the National Electrical Code.

- Grounded and bonded per NEC 600.7/NEC 250
- Existing branch circuit in compliance with NEC 600.5, not to exceed 20 amps
- Sign is to be UL listed per NEC 600.3
- UL disconnect switch per NEC 600.6- required per sign component before leaving manufacturer*
*For multiple signs, a disconnect is permitted but not required for each section

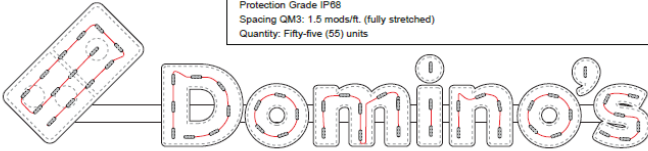

2 LED PATTERN
SCALE: 1/2\" = 1'-0\"

1 LETTER DETAILS

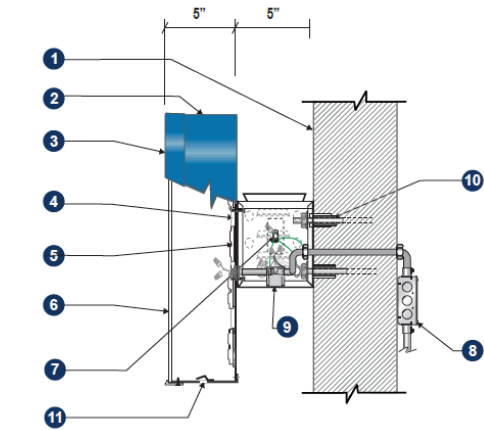

3 Section @ LED Channel Letter
Front-Lit (Remote)

Domino's Domino's Horizontal Wordmark Channel-Raceway_24\" Blue

sales@indiesignage.com
(623) 302-4545

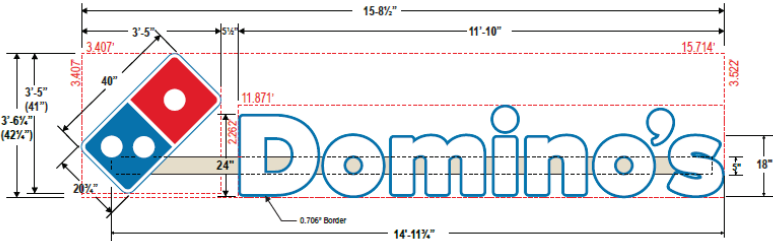

SIGN AREA
BOXED LOG & LETTERS: 38.53 SQ. FT.
SINGLE BOX: 55.34 SQ. FT.

SIGNA	
Type:	Domino's Horizontal Wordmark Channel-Raceway_24\" White
Individual Channel Letters w/ Raceway	
Illumination:	Internally Illuminated LED
Square Footage:	53.87
To Grade:	Top of Sign to Grade = Bottom of Sign to Grade =



A Dom Horiz WM Channel-Raceway 24\" White QTY: ONE (1) SET
SCALE: 1/2\" = 1'-0\" AREA: 55.34 SQ. FT.

Electrical Detail:	
White LEDs	
(1) 80w Transformer GEPS12-80U-NA	
Total Amps: 0.60	
(1) 20 amp 120V Circuit Req.	

Specifications: Channel Letter & Logo Set

- Existing Facade: TBD
- 040 Aluminum returns painted PMS 307 C Blue for letters and White for logo. Semigloss finish.
- Jewellee trimcap bonded to face, #6 pan head screws to returns painted to match PMS 307 C Blue for letters and White for logo
- 3mm Signabond Lite composite backs fastened to returns w/ 1/2\" 18 gauge staples. Seal w/ VOC compliant 360 white latex caulk to prevent moisture intrusion.
- Principal Qwik Mod 3 White LEDs
- 3/16\" White acrylic faces w/ translucent vinyl applied to faces
- 3M 3730-127 Intense Blue
- 3M 3730-33 Red (for Logo)
- 3M blackout white for \"S\" centers
- Disconnect switch UL Outdoor rated toggle type w/ neoprene boot per NEC 600-6
- Primary electrical feed in UL conduit / customer supplied UL junction box
- Transformers within UL enclosure (removable lid), 5\"x5\" Raceway, paint to match fascia
- Mounting hardware to suit.
- 1/4\" Drain holes w/ light baffles at bottom of letter cans (2) per letter

Specifications: Principle Qwik Mod 3 LEDs

Beam Angle 170° Ultra-Wide Low Dome Batwing Optic with Diamondback Optic Lens Technology
Certifications UL & cUL Recognized (SAM Manual), CE, RoHS, CSA
Dimensions QM3: 0.60\"W x 3.14\"L x 0.25\"H
Fastening Peel & stick / Mechanical screw hole
Input 12VDC, Power Supply P-LED 12VDC
Protection Grade IP68
Spacing QM3: 1.5 mods/ft. (fully stretched)
Quantity: Fifty-five (55) units

General Notes:
This sign is to be installed in accordance with the requirements of Article 600 of the National Electrical Code.

- Grounded and bonded per NEC 600.7/NEC 250
- Existing branch circuit in compliance with NEC 600.5, not to exceed 20 amps
- Sign is to be UL listed per NEC 600.3
- UL disconnect switch per NEC 600.6- required per sign component before leaving manufacturer*
*For multiple signs, a disconnect is permitted but not required for each section

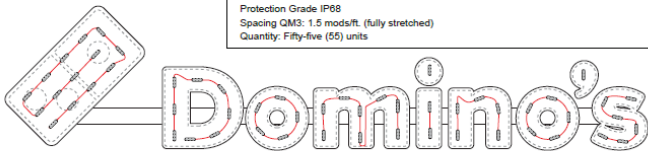

2 LED PATTERN
SCALE: 1/2\" = 1'-0\"

1 LETTER DETAILS

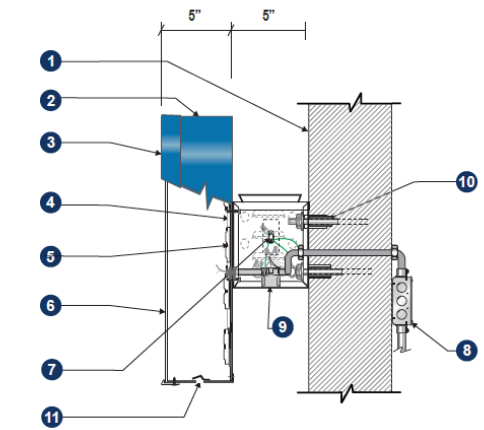

3 Section @ LED Channel Letter
Front-Lit (Remote)

Domino's Domino's Horizontal Wordmark Channel-Raceway_24\" White

sales@indiesignage.com
(623) 302-4545

Carside Delivery / Pickup Parking Sign



Dom Curbside Sign_Domino's Carside Delivery

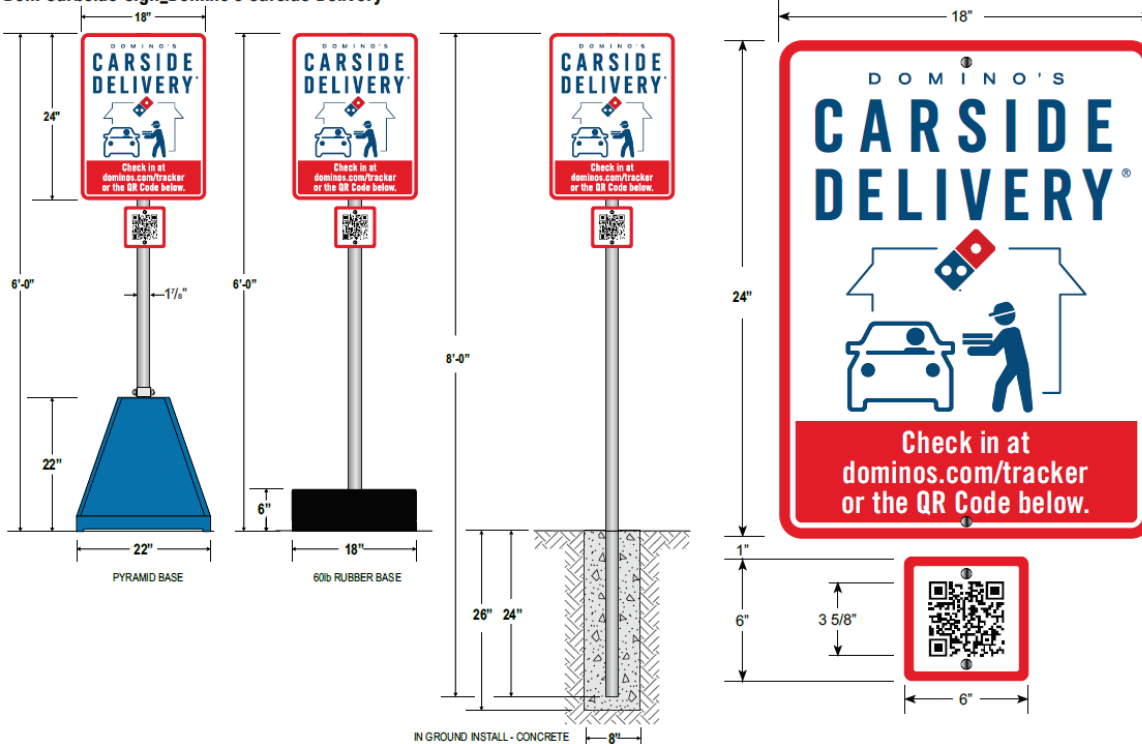

SIGN A	Dom Curbside Sign_Carside Delivery
Type:	Regulatory/Informational/Curable
Material:	W/A
Area Sq. Ft.:	3.35

Specifications:	
SIGN SUBSTRATE:	<ul style="list-style-type: none"> • .050" ALUMINUM
SIGN ARTWORK / COPY:	<ul style="list-style-type: none"> • DIGITAL PRINT ON WHITE VINYL WITH CLEAR U.V. LAMINATE OR DIRECT PRINT TO SUBSTRATE
SIGN BASE MATERIAL:	<ul style="list-style-type: none"> • 1/2" NOMINAL WALL THICKNESS • LOW DENSITY POLYETHYLENE THERMOPLASTIC WITH ULTRAVIOLET AND ANTI-STATIC ADDITIVES
SIGN POST MATERIAL:	<ul style="list-style-type: none"> • SIGN HOLES CAN BE FIELD DRILLED OR ADDED SIGN BRACKETS FOR AN EASY ADJUSTABLE INSTALLATION • 1.06 O.D. 14 GAUGE STEEL SLEEVE IN HOPE PLASTIC • 1.0" O.D. WITH PLASTIC CAP
SIGN BASE DIMENSIONS	<ul style="list-style-type: none"> • 22" HIGH 22" WIDE x 22" DEEP • 1/2" NOMINAL WALL THICKNESS
WHEELS:	<ul style="list-style-type: none"> • OPTIONAL
WEIGHT:	<ul style="list-style-type: none"> • 30 LBS. WITH POLE WHEN EMPTY OF BALLAST WEIGHT
COLORS:	<ul style="list-style-type: none"> • STANDARD COLORS: DOMINO'S BLUE BASE W/ GREY POLE
HEIGHT:	<ul style="list-style-type: none"> • STANDARD HEIGHT IS 84" WITH OR WITHOUT WHEELS
PYRAMD BASE INSTALLATION:	<ul style="list-style-type: none"> • FILL WITH SAND OR GRAVEL BALLAST, OR FILL WITH WATER AND STABILIZING GEL FOR BALLAST • CAN HOLD UP TO 250 LBS. OF BALLAST



A CARSIDE DELIVERY SIGN
SCALE: 1" = 1'-0"

1 Panel Detail - suitable for production
SCALE: 3" = 1'-0"

2 Add-on Wheels Option



Dom Curbside Sign_Domino's Carside Delivery



sales@indiesignage.com
(623) 302-4545

In Line Channel

Primary Horz + PU (with RIGHT arrow)

Primary Horz + PU - Option 1 Primary Horz + PU - Option 2

Primary Horz + PU - Option 3 Primary Horz + PU - Option 4

Secondary Horz + PU (no arrow)

Secondary Horz + PU - Option 1 Secondary Horz + PU - Option 2

Secondary Horz + PU - Option 3 Secondary Horz + PU - Option 4

Pylon/Pole Signs (left or right arrow)

Primary (Pylon or Pole) Secondary (Pylon) for use when Primary is not allowed due to local requirements Secondary (Pole) for use when Primary is not allowed due to local requirements

Primary: No Directional Arrow Secondary: No Directional Arrow Secondary: No Directional Arrow

Directional Sign (left or right arrow)

Blade Sign (left or right arrow)

For placement AW window or to indicate a turn around a corner of the building when needed to reach the window

For placement near corner of window wall to increase visibility

To deter incorrect traffic flow

Stacked Channel (left or right arrow)

Stacked WM Stacked WM + PU - Primary1 Stacked WM + PU - Secondary2

Monument

Monument Directional

Awning - can be executed with or without tile logo, depending on other branding on face of building

Canopy - can be executed with or without type

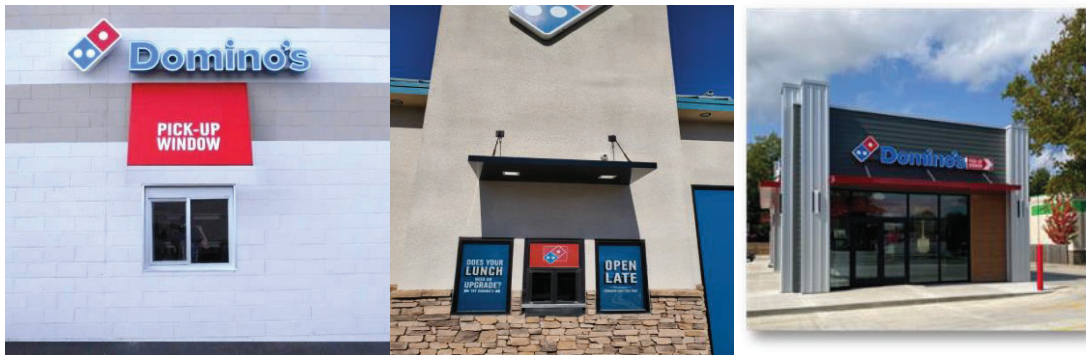

EXHIBIT M

RIDER TO PURCHASE AGREEMENT

RIDER TO PURCHASE AGREEMENT

THIS RIDER TO PURCHASE AGREEMENT (the “Rider”) is made this _____ day of _____ 20____, by and between: _____ (the “Seller”) and _____ (the “Purchaser”).

WHEREAS, concurrently with the execution of this Rider, Seller, a franchisee of Domino’s Pizza Master Issuer LLC (DPMI”) and/or Domino's Pizza Franchising LLC (“DPF”), and Purchaser, have entered into a Purchase Agreement for the sale of Seller’s assets used in the operation of the Domino's Pizza Store(s) listed on the attached Exhibit A (the "Store(s)") to Purchaser.

WHEREAS, Purchaser has applied to Domino’s Pizza LLC, as Manager (“DPL”), for approval to operate the Store(s) as a Domino’s Pizza franchisee and approval of Purchaser’s application is conditioned, among other things, upon certain provisions being contained in the Purchase Agreement for the Store(s).

WHEREAS, to evidence Seller’s and Purchaser's agreement to include these terms in the Purchase Agreement, the parties hereby enter into this Rider.

NOW, THEREFORE, the parties agree as follows:

1. **Purchase Agreement.** For the purposes of this Rider, the term “Purchase Agreement” shall mean the documents executed or delivered by and between Seller and Purchaser for the transfer of the assets of the Store(s) from Seller to Purchaser, regardless of the name or title on the documents.

2. **Inconsistency Between Agreements.** In the event of any inconsistency between the terms of the Purchase Agreement, any and all other related documents executed in connection with the purchase of the assets of the Store(s), and this Rider, the terms of this Rider shall prevail. If there is any inconsistency between any franchise agreement(s) to which Seller or Purchaser is a party (the “Franchise Agreement(s)”), and the Purchase Agreement, including this Rider, the terms of the Franchise Agreement(s) shall prevail. Without limiting the generality of the foregoing, sales or transfers of all or a part of any interest in the assets of a Domino’s Pizza store, or the entity owning the Store(s) remain subject to the prior rights of DPMI, DPF and/or DPL as provided in the Franchise Agreement(s).

3. **Disclaimer of Interest in Telephone Numbers/Intellectual Property.** The assets to be transferred pursuant to the Purchase Agreement do not include, nor shall any value be assigned to: (i) telephone numbers, (ii) the Domino’s trademarks/tradenames, (iii) the Franchise Agreement(s), (iv) geographic areas or (v) any rights granted under the Franchise Agreement(s).

Further, Seller and Purchaser acknowledge that the rights to the current telephone number(s) to the Store(s) (the “Phone Number(s)”) are held by DPL. However, as the telephone service provider(s) of the Phone Number(s) may not recognize this right of DPL, Seller agrees to provide the necessary documentation to the telephone service provider(s) to assign such Phone Numbers to the Purchaser.

4. **Outstanding Debts/DMA Co-op Obligations.** All outstanding debts owed to DPMI, DPF, Domino's Pizza Distribution LLC ("DPD") and any of their affiliates or subsidiaries, contractual and local DMA commitments accrued as of the date of closing, must be paid in full prior to or at the closing. DPL may, at its discretion, require outstanding debts to be paid via wire transfer to the appropriate creditor.

Purchaser hereby formally assumes all of Seller's obligations under all contractual and local DMA Co-op commitments and contracts.

5. **Clearance Letter/Purchaser's Joint Liability.** Prior to taking possession of the subject of the Purchase Agreement, or paying any part of the price therefor, Purchaser shall obtain written verification from DPL of amounts owed by Seller to DPMI, DPF, DPD and any of their affiliates or subsidiaries and local DMA commitments. Purchaser may satisfy this obligation by obtaining a completed "Clearance Letter" in a form of the Exhibit B attached to this Rider which must be signed by DPL and Seller at least one (1) business day prior to the closing. By signing this Rider, Seller authorizes Purchaser to pay the amounts to the respective entities as set out on the applicable Clearance Letter by *Wire Transfer on the day of the closing*. For failure to comply with the provisions of this paragraph, Purchaser agrees to be liable with Seller for payment of the liabilities set out on the Clearance Letter and the individual signing this Rider for the Purchaser shall also be personally liable for payment of the liabilities set out on the Clearance Letter, and such liabilities may be enforced against Seller, Purchaser, and Purchaser's signatory, jointly and severally. Purchaser and Purchaser's signatory also authorize DPF to withhold profit sharing and volume discount payments otherwise due Purchaser for payment of liabilities assumed by Purchaser under this paragraph.

In addition, Seller, Purchaser, and Purchaser's signatory shall be jointly liable for interest at the rate of twelve percent (12%) per annum on any amount not paid to the payee according to the Clearance Letter by Wire Transfer on the day of the closing, as well as all of the payee's costs (including attorney's fees) incurred in collecting the amounts due according to the Clearance Letter.

Nothing set forth in this paragraph relieves Seller of any liability to pay amounts due at closing.

6. **No Security Interest.** Purchaser acknowledges and agrees that it shall not grant a security interest in, or pledge as collateral of, any interest in any premise lease, franchisee, Franchise Agreement(s), or any franchise rights thereunder, and Seller acknowledges that it will not attempt to acquire any such security interest.

7. **Delivery Area.** Neither Seller nor Purchaser has the authority to change the boundaries of the delivery area of any Store(s) without the written consent of DPL or DPF. If there are any discrepancies over the exact boundaries of the delivery area of any Store(s), the boundaries that are set out on the map maintained by DPL or DPF shall control.

Seller agrees to disclose to Purchaser, prior to closing any limitations Seller has placed on delivery service offered by the Store(s) and furnish Purchaser with copies of documents supporting Seller's reasons for, and other information about, the limitations.

Purchaser acknowledges that it is familiar with the boundaries of all delivery areas and further agrees to make an independent review and evaluation of the entire delivery area(s) of

the Store(s) within thirty (30) days after closing and Purchaser shall adopt and implement its delivery service policy in accordance with the Domino's Pizza Limited Delivery Service Policy and Standard.

8. **Sale Information.** Seller and Purchaser agree that DPL, DPF, DPMI and their subsidiaries and affiliates do not represent or warrant the accuracy of any information Seller has provided to Purchaser in connection with this transaction and DPL, DPF, DPMI and their subsidiaries and affiliates shall have no liability for the information or failure to provide information.

IN WITNESS WHEREOF, the parties have executed this Rider on or as of the date first above written.

SELLER: _____

PURCHASER: _____

By: _____

By: _____

Its: _____

Its: _____

EXHIBIT A

Initial

Store #

Store Address

EXHIBIT B

Example FORM OF Domino's Pizza Clearance Letter

It is agreed that as of _____, 20___, [Franchisee's Name], individually and as Controlling Owner (the "Seller") of Domino's Pizza Store(s) # _____ (the "Stores"), whose assets are being sold pursuant to the terms of a certain "Purchase Agreement", is indebted in the following amounts:

- Royalties & Advertising	\$ _____
- Equipment & Supply	\$ _____
- Supply Chain Center	\$ _____
- Technology (i.e. OLO, Pulse, etc.)	\$ _____
- Internal Promissory Notes	\$ _____
- Miscellaneous	\$ _____
TOTAL DUE AT CLOSING:	\$ _____

Seller must sign and return this Clearance Letter to Domino Pizza LLC at least one (1) business day prior to the closing. Seller authorizes the release of this information and authorizes and agrees to the following:

On or before the date of the transaction, either: (1) the Seller will pay the total amount due at closing by Wire Transfer; or (2) the Purchaser of the assets of the Stores, upon agreement with Seller, will pay the total amount due at closing by Wire Transfer. Further, should any payments previously made via the Domino's Online Payment System (DOPS) fail to clear by the closing date, the amounts pending will become due immediately and payment in full will be made at closing.

This Clearance Letter has been prepared by Domino's Pizza LLC, as Manager, according to the best information available to it at the time it is prepared. **In the event it is later determined that any amount above had been incorrectly calculated, either (1) the appropriate Domino's Pizza entity shall refund any amount overpaid, or (2) the Seller shall remain liable for, and pay on demand, any additional amount due.**

Please send the **Wire Transfer** in the amount of \$ _____ on or before the day of the transaction to:

JP Morgan Chase
New York, NY 10005
Domino's Pizza
ABA # 0210-0002-1
Acct # 1270623

Domino's Pizza LLC, as Manager

Acknowledged By:

By: _____

Seller: _____

(Signature)

(Signature)

(Print "Name" Above)

(Print "Name" Above)

EXHIBIT N

OPERATING MANUAL TABLE OF CONTENTS

Contents

Introduction	1
Variances	1
“Domino’s”	1
“Franchisee”	1
Compliance	1
Food and Beverage Items Not For Resale	3
Vending Machines	3
Accessibility Posting	3
Tobacco	3
Emergency Protocols	3
Gambling and Gaming Machines	3
Credit Cards	3
Gift Cards	3
Menus	3
Literature and Temporary Holiday Decorations	3
Store Hours	4
Ambient Store Temperature	4
Cleaning and Sanitizing	4
Domino’s Carside Delivery™	4
Domino’s Pinpoint Delivery™	4
Operating Standards	4
Franchisee Corporate Name	4
Delivery Charge	5
Customer Care	5
Store Profit and Loss Statements	5
Apparel and Appearance	5
Apparel	6
Shirts	6
Pants, Shorts, Skirts, Capris, and Belts	6
Hats, Head Coverings, Visors, and Gloves	6
Nametags	6
Pins and Hat Clips	7
Shoes and Socks	7
Aprons and Jackets	7
Non-Store Personnel	7
Embroidery Guidelines	7
Hygiene	8
Hair	8
Facial Hair	8

Jewelry	8
Tattoos	8
Body Modification or Alteration	8
Criminal Background Checks	9
Applicant Tracking System	9
Training	10
Store Computers	10
Telephone Equipment	13
Bump Bars	13
Connectivity.....	13
In-Store Guest Wi-Fi Network	13
Call Catcher/Sequencer Systems	14
Spanish Language Call Center	14
Marketing and Advertising	14
Free Delivery.....	14
Digital Communication to Customers	15
Third-Party Order Aggregators	15
Marketing and Advertising Alerts to Customers	15
Limited Delivery Service	15
Safety and Loss Prevention	16
Cash Control Tools	16
Time-Delay Safe	17
Dual-Key Controlled Safe/Smart Safe	17
Conversations about Cash or Sales Volumes	17
Delivery Personnel Cash and Drops.....	17
Till/Cash Drawer	17
Receipts and Bulk Cash.....	17
Door Security	17
Store Closing.....	17
Fire Extinguishers and Flammable Liquids.....	18
Weapons and Weapon Paraphernalia.....	18
Caller Identification	18
Security Callbacks	18
Children and Animals.....	18
Alcohol, Marijuana, and Illegal Controlled Substances	18
Operating a Motor Vehicle	19
Driving History.....	19
Driving Record	19
Periodic Delivery Vehicle Inspection.....	20
Delivery Vehicle Appearance.....	20
Radar Detectors and Keys.....	20

Seat Belts	20
Mobile Device Use	21
Delivery Vehicle Passengers	21
Minimum Service	21
Bicycles and eBikes	21
Mopeds and Scooters	22
Motorcycles	22
Leave at Door.....	22
Delivery	22
Cutting Edge	23
Domino's Global Positioning System and Digital Shoulder Surfing Technology Platforms	23
Pick-Up Windows.....	23
Pie Pass® Pickup Units	23
Third-Party Order Takers	24
Retention and Sharing of Customer Data and Confidential or Proprietary Information with Third Parties	24
Load & Go	25
Electric Vehicle Charging Stations.....	26
DJ Dough Spinner.....	26

CONTENTS

Introduction..... 1

Variances..... 1

“Domino’s” 1

“Franchisee” 1

Compliance..... 1

Food Product Storage, Handling, Dating and Ingredients 3

Product Transporting/Holding/Discarding 5

Pizza Standards 6

Dough Proofing Information 7

Baking Standards..... 8

Hand Tossed Pizza 11

Brooklyn Style Pizza..... 13

Pan Pizza 14

Thin Crust Pizza 15

Gluten Free Crust..... 17

Domino’s Pizza Sauce Information 18

Domino’s Cheese Information..... 18

Itemization/Toppings 20

Toppings on the Side 21

Pizza Product Itemization and Portioning 22

Domino’s Specialty Pizzas 26

Bread Twists..... 31

Oven-Baked Dips 32

Stuffed Cheesy Bread (for all builds) 33

Parmesan Bread Bites 34

Wings and Wing Sauces 35

Domino’s Boneless Chicken 37

Specialty Chicken..... 38

Oven Baked Sandwiches 40

Loaded Tots 42

Pasta 43

Chocolate Lava Crunch Cakes 45

Marbled Cookie Brownie 46

Domino’s Salads 47

Ready to Go Product..... 47

Beverages 48

Approved Dipping Cups 49

EXHIBIT O

APPLICATION FOR FRANCHISE (RENEWAL)

APPLICATION FOR FRANCHISE (RENEWAL)

I, (insert franchisee's name), as owner or controlling person of (insert franchisee's entity name) ("Franchisee" or "I"), who operates Store #(insert) located at (insert store address) (the "Store"), certify as follows:

1. I have the authority to renew the existing Standard Franchise Agreement (the "SFA") on behalf of all other owners for the Store listed above and understand that, to the extent necessary for accurate, complete and full disclosure, I shall attach to this application (the "Application") any clarification or explanation of the items listed below, which shall be considered incorporated into this Application.

2. I have paid amounts due for all royalties, advertising contributions and other amounts due to Domino's Pizza Master Issuer LLC or Domino's Pizza Franchising LLC (as applicable) and all other related or affiliated entities (collectively "Domino's Pizza" or "Us").

3. I have paid all amounts due to all creditors including, without limitations, lenders, suppliers and taxing authorities.

4. I have a fully executed lease for the Store premises or own the Store premises and have obtained all required licenses, permits and certificates necessary for the operation of the Store and have operated the Store in full compliance with all applicable laws, ordinances and regulations.

5. I have properly trained my employees and acknowledge that said employees are employed and supervised by me. I have paid and otherwise treated my employees in accordance with, or as required by, applicable law. Neither I nor any of the Store managers or supervisors have engaged in any act or refrained from taking action that would make or deem any of such employees to be employees of Domino's Pizza.

6. I have obtained the minimum levels of insurance and coverage as required by the SFA.

7. I confirm that the ownership structure of (insert franchisee's entity name) is currently as follows:

-
-

8. I am not in material default of any provision of the SFA or any other agreement with Domino's Pizza and have substantially complied with the terms and conditions of said SFA and any other agreement(s) with Domino's including, without limitation:

- i. At all times, I have maintained the absolute confidentiality of the Operating Manual, Customer Lists, and all other information concerning the Domino's system, as required by the SFA, and have disclosed this information to the other employees of the Store only to the extent necessary for the operation of the Store in accordance with the SFA; and

- ii. I have not used the Operating Manual, Customer Lists, or any other information concerning the Domino's system in any other businesses or in any manner not explicitly approved by Domino's Pizza in writing, as required by the SFA; and
- iii. I have devoted full time and efforts (excluding reasonable vacation periods) to the management of the Store or other Domino's Pizza Stores and have not engaged in any other business activity without Domino's Pizza's prior written consent; and
- iv. I have not been convicted of a felony, or a crime which substantially impairs the goodwill associated with the Marks, nor have I or any of the other owners engaged in any conduct which adversely affects the reputation of the Store or the Domino's System or the goodwill associated with the Marks or involves dishonesty, fraud, deceit, illegal conduct misrepresentation or moral turpitude.

9. I have received Domino's Pizza's most current version of the Franchise Disclosure Document (the "FDD"), which includes, among other items, the most current form of the SFA.

10. I acknowledge that the FDD receipt form, this Application and all other documents required by Domino's Pizza to issue the renewal SFA must be fully executed and received by Domino's Pizza by _____ in order for Domino's Pizza to issue the renewal SFA. I further acknowledge that once I receive the renewed SFA, I will have thirty (30) days to fully execute and return it to Domino's Pizza and my failure to return the renewal SFA within thirty (30) days of receipt will be deemed an election by me to not renew the SFA.

11. I give Domino's Pizza permission to obtain background information, including but not limited to references, credit reports, motor vehicle reports, information from governmental agencies and others concerning residency status and employments eligibility and conduct criminal investigations, at this time and from time-to-time thereafter and I release Domino's Pizza and/or its agents and any person or entity which provides information pursuant to this authorization, from any liabilities, claims or causes of action in regards to the information obtained from any and all of the references used.

12. I acknowledge that the representations and statements contained in this Application are accurate and complete and I have fully disclosed all information relating thereto. I also acknowledge that this Application is being delivered to Domino's Pizza to induce it to enter into the renewal SFA.

FRANCHISEE/CONTROLLING OWNER:

By: _____

Its: _____

Dated: _____

EXHIBIT P

**DOMINO'S PIZZA ONLINE ORDERING FRANCHISEE SERVICES
AGREEMENT**

Domino's Pizza Online Ordering Franchisee Services Agreement

This Online Ordering Franchisee Services Agreement (this "Agreement"), dated _____, 20__, is by and between Domino's Pizza Distribution LLC, its parents, subsidiaries and affiliates, ("Domino's") and <<Franchisee Name>>("Controlling Owner") and all corporations, partnerships, limited liability companies or other business entities owned by the Controlling Owner (referred to collectively herein as "Franchisee").

WHEREAS, Domino's has developed an online ordering engine ("OLO") for internet based orders ("Web Orders") to be used by Domino's Pizza franchisees in Domino's Pizza stores (each a "Store" and collectively, the "Stores") operating the Domino's PULSE computer system. Franchisees will be responsible for payment of the OLO Fees in the Franchisee's Stores and Domino's will invoice and collect from participating franchisees the OLO Fees in the Franchisee's Stores; and

WHEREAS, Franchisee desires to have all Stores in which Franchisee owns a controlling interest receive Web Orders according to the terms of this Agreement and the rules, standards and policies set from time to time related to Web Orders. For purposes of this Agreement "owns a controlling interest" shall mean any Store in which the Franchisee has at least a 51% ownership interest.

NOW THEREFORE, in consideration of the premises, the mutual promises contained herein, and other good and valuable consideration, receipt of which is hereby acknowledged, the parties agree as follows:

1. Term; Termination

1.1 The term of the Agreement shall commence upon acceptance of this Agreement by Domino's at its offices in Ann Arbor, Michigan, and shall remain in force for a period of five (5) years (the "Original Term"), except as otherwise stated. At the end of the Original Term, this Agreement shall automatically renew for successive one (1) year terms (each, a "Renewal Term"), unless cancelled by either party by giving not less than sixty (60) days' written notice prior to the expiration of the Initial Term or a Renewal Term, as the case may be.

1.2 Either party may terminate this agreement in the event of any breach by the other party which breach is not cured within thirty (30) days after receipt of written notice of such breach, except for termination in accordance with Section 3.2 below.

1.3 Domino's may terminate the Agreement: (i) at any time on written notice to Franchisee; or (ii) in the event of nonpayment by Franchisee if such breach is not cured within ten (10) days after receipt of written notice.

1.4 Franchisee may terminate this Agreement at any time.

1.5 This Agreement shall terminate immediately upon (a) Franchisee's bankruptcy or insolvency; (b) the cessation of Franchisee's business operations as a Domino's Pizza franchisee or the termination or non-renewal of the Franchise Agreement for the Store; (c) the cessation of Franchisee's use of the Domino's Pulse system; or (c) for the reasons set out below in section 3.

1.6 Upon any termination of the Agreement, Franchisee shall immediately terminate the use of the OLO and Domino's shall have the right to terminate Franchisee's use of OLO. Franchisee is still responsible to pay for any orders that were placed prior to termination of agreement. The provisions of this Agreement relating to title and ownership as set forth in Section 3 and the confidentiality provisions in Section 6.7 shall survive any termination of this Agreement.

2. Fees and Charges; Invoices and Payment

2.1 Franchisee agrees to pay \$0.355 per Web Order for all Web Orders occurring in the Stores. A Web Order shall include any order transferred to the Store via the OLO system including orders not fulfilled by the Store for any reason. The transaction fees to be paid by Franchisee shall be invoiced by Domino's on a quarterly basis, or on such other periodic basis as Domino's determines in its sole discretion. Domino's shall provide the Franchisee with data supporting the transaction count used to determine the total Web Order transaction fees via Domino's Online including Domino's Pulse order identification, Web Order date, Web Order time and Web Order ticket amount and Franchisee agrees to provide information and documents requested by Domino's pertaining to Web Orders.

2.2 Franchisee agrees to accept an electronic invoice from Domino's for all fees and remit payment via the Domino's Online Payment System or as otherwise from time to time instructed by Domino's. Domino's will send the electronic invoice to the Franchisee's email address provided to Domino's. Payment is due upon receipt of invoice, without set-off or claim. If payment is not received within fifteen (15) days from receipt of invoice Domino's may: (i) assess a charge not to exceed one and a half percent (1.5%) per month on all amounts due; and/or (ii) pursue other remedies available at law, or pursuant

to other agreements between Franchisee and Domino's, or pursuant to this Agreement. All prices and payments are in U.S. dollars.

2.3 The Web Order transaction fee invoiced by Domino's pursuant to Section 2.1 of this Agreement may be affected by external pressures including but not limited to changes in third party charges, overall usage of OLO by the Domino's Pizza system and technological advances. Accordingly, Domino's reserves the right to adjust (either increase or decrease) the Web Order transaction fee described in Section 2.1 of this Agreement at any time with ninety (90) days prior notice to Franchisee. The Domino's Technology Advisory Board will review any Web Order transaction fee increases. Such changes to the Web Order transaction fee, if any, would apply only to Web Orders completed after such notice of such a Web Order transaction fee adjustment is given.

3. Ownership Rights; Nondisclosure

3.1 All rights to patents, copyrights, trademarks and trade secrets in the OLO or any modifications shall remain with Domino's and/or with the respective manufacturer or author.

3.2 Domino's may immediately terminate this Agreement in the event Franchisee violates or infringes on the intellectual property rights of another with respect to OLO, or challenges the ownership rights as set out above in section 3.1.

4. Limitation of Liability

DOMINO'S SHALL HAVE NO LIABILITY WHATSOEVER UNDER THIS AGREEMENT FOR ANY DAMAGES, INCLUDING BUT NOT LIMITED TO SPECIAL, INDIRECT, CONSEQUENTIAL, INCIDENTAL, PUNITIVE, LOSS OF PROFITS OR EXEMPLARY DAMAGES UNDER ANY CIRCUMSTANCES, WHETHER BASED ON TORT OR BREACH OF CONTRACT CLAIMS OR ON ANY OTHER BASIS, EVEN IF IT HAS BEEN ADVISED OF THE POSSIBILITY OF SUCH DAMAGES.

5. Franchisee Data

Franchisee agrees that Domino's may, at any time, have full access, both on-site and from a remote location, to all of Franchisee's computer data, equipment and systems containing any and all of the information, records and reports relating to OLO and to use the data in the evaluation of OLO and in the preparation of invoices for OLO in accordance with this Agreement. Domino's will use the same degree of care to protect against the unauthorized use of the information by third parties as it does with respect to its own information of a similar type. In addition, Domino's is responsible for the security of cardholder data that Domino's possesses or stores, processes or transmits on behalf of the Franchisee, or to the extent that they could impact the security of the Franchisee's cardholder data environment.

6. General

6.1 This Agreement and all addenda, if any, supersedes in full all prior discussions and agreements, oral and written, between the parties relating to OLO and Web Orders and constitutes the entire agreement between the parties relating to OLO and Web Orders. This Agreement may be modified or supplemented only in writing signed by an authorized representative of each party.

6.2 Neither party shall be liable for delays in any of its performance hereunder due to causes beyond its reasonable control, including, but not limited to, acts of God, strikes or inability to maintain labor or materials on time.

6.3 If any provision of this Agreement shall be deemed illegal or otherwise unenforceable, that portion shall be severed and the remainder of this Agreement shall remain in full force and effect. A waiver shall be effective only if made in writing and signed by an authorized representative of both parties. The waiver of any right or election of any remedy in one instance shall not affect any rights or remedies in another instance.

6.4 All required notices under this Agreement shall be given by regular mail, facsimile or other electronic system such as email.

If to Domino's: Domino's Pizza Distribution LLC
24 Frank Lloyd Wright Drive
PO Box 485
Ann Arbor, MI 48106

If to Franchisee, required notices shall be addressed to the most current business address, home address or email address sent by Franchisee to Domino's in writing.

Such notices shall be deemed given on the date of receipt (or refusal) of delivery of said notice.

6.5 This Agreement shall be governed by the laws of the State of Michigan.

6.6 Neither party to this Agreement is, or shall represent itself to be, an agent, partner, or employee of the other. Nothing in this Agreement shall be interpreted or construed as creating or establishing a joint venture, agency, or partnership, or any relationship other than independent parties to a contract. Each party retains control of the day to day activities of its respective business.

6.7 Domino's reserves the right to enter into agreements with third-party providers for any part of the OLO functionality without Franchisee consent during the term of this Agreement.

6.8 Franchisee acknowledges that during the term of this Agreement, it may obtain access to confidential and proprietary information, trade secrets and financial information (the "Confidential Information") relating to OLO and Web Orders. Franchisee acknowledges that Domino's would be irreparably damaged by the disclosure of the Confidential Information to others. Therefore, Franchisee agrees to keep secret and confidential and not to disclose the Confidential Information of Domino's relating to OLO and Web Orders without the prior written consent of Domino's. The agreement not to disclose the Confidential Information shall survive the expiration of this Agreement.

IN WITNESS WHEREOF, the parties have caused this Agreement to be executed on the date first written above.

Domino's Pizza Distribution LLC

Franchisee: <<Franchisee Name>>

By: _____
Name: Kevin S. Morris
Title: EVP, General Counsel, Corp. Secretary

Signature: X _____
Print Name: X _____

EXHIBIT Q

TERM SHEET

(Insert Term Sheet Type Title) (the “Term Sheet”)

for

_____ **(“Franchisee”)**

- **Franchisee acknowledges that this Term Sheet sets forth the Franchisee’s commitment to build either a single store OR multiple stores over a fixed period of time. This Term Sheet will be memorialized by a formal Development Agreement (the “Agreement”) that will be created and executed by and between Franchisee and Domino’s Pizza Franchising LLC (“DPF”).**
- Franchisee agrees to open ___ (_____) store(s) (the “New Store(s)”) by the following required open by date(s) (the “Required Open By Date”) in _____ DMA(s):
 - ___ by _____
 - ___ by _____
 - ___ by _____
 - ___ by _____
 - ___ by _____
- DPF agrees, upon execution of the Agreement, to grant exclusive rights to the areas listed below:

Greenspace Territory	Split Territory
DMA Territory # _____ (City, St)	DMA Territory # _____ (City, St)
DMA Territory # _____ (City, St)	DMA Territory # _____ (City, St)
DMA Territory # _____ (City, St)	DMA Territory # _____ (City, St)
DMA Territory # _____ (City, St)	DMA Territory # _____ (City, St)
DMA Territory # _____ (City, St)	DMA Territory # _____ (City, St)

- Franchisee acknowledges that each New Store required under the Agreement will be associated with a deferred twenty-five-thousand-dollar (\$25,000.00) fee (the “Reservation Fee”) unless otherwise modified or reduced by DPF.
- Franchisee acknowledges that if a New Store is not opened by its Required Open By Date the Reservation Fee shall be required to be paid to DPF within 30 days of written notice from DPF. Notwithstanding the foregoing, Franchisee shall not be obligated to pay the Reservation Fee if:
 - A copy of an executed approved lease is received by Franchise Services within 90 days after the Required Open By Date (“Criteria 1”); OR
 - If Criteria 1 above is met and Franchisee begins approved construction on the New Store within 180 days after the Required Open By Date.
- Franchisee acknowledges that the franchise fee for each New Store is ten thousand dollars (\$10,000.00) (the “Franchise Fee”).
- Franchisee acknowledges that a new Domino’s Pulse System (“DPS”) will be purchased for each New Store and the DPS must be installed by a Domino’s Pizza LLC approved Domino’s Pulse

installer. Franchisee further understands and acknowledges that the Domino's Pulse Software license fee, as defined in Attachment A of their "Domino's Pulse System License Agreement", is currently \$4,200.00.

- DPF agrees to offer the Franchisee the following incentives under the Agreement:

1) Royalty and Advertising Rate Incentives:

(to be completed as applicable)

Royalty Rate Contributions and Cumulative Advertising Contributions Schedule:

Royalty rate contributions and cumulative advertising contributions for the New Store will be reduced according to the following schedule until the point in time at which the amount for the maximum eligible incentive amount value is met:

- i. For weeks 1 through 52 the royalty rate contribution and required cumulative advertising rate contributions requirement will each be reduced by 5%;
- ii. For weeks 53 through 104 the royalty rate contribution and required cumulative advertising rate contributions requirement will each be reduced by 4%; and
- iii. From week 105 and forward the royalty rate contribution and required cumulative advertising rate contributions requirement will each be reduced by 3%.

Franchisee agrees to the terms set forth above and acknowledges that the terms of this Term Sheet will be formalized in connection with the execution of the Agreement.

Franchisee also acknowledges and agrees that the terms of this Term Sheet must be executed and returned to _____ by no later than the end of business on _____.

By: _____

Dated: _____

Franchisee Name

Franchisee may not sign the Term Sheet until the "Controlling Person", as defined in the Standard Franchise Agreement, has been disclosed with DPF's current Franchise Disclosure Document and the required federal and state holding periods have elapsed.

EXHIBIT R

GLOBAL POSITIONING SYSTEM TECHNOLOGY PLATFORM AGREEMENT

Global Positioning System Technology Platform Agreement

This Global Positioning System Technology Platform Agreement (this "Agreement") is by and between Domino's Pizza Distribution LLC ("Domino's") and _____ (the "Controlling Owner") and all corporations, partnerships, limited liability companies, or other business entities owned by the Controlling Owner (collectively, "Franchisee" in this Agreement).

WHEREAS, Domino's has developed a Global Positioning System ("GPS") technology platform, including a Domino's Driver App (the "Driver App"), to, among other things, enable the location-tracking of deliveries electronically (collectively, the "Platform");

WHEREAS, Domino's is willing at this time to offer the Platform to franchisees as an optional service, and

WHEREAS, Franchisee owns and is the franchisee of record for Domino's-branded store(s) (the "Stores") and desires to voluntarily utilize the Platform in those Stores according to the terms of this Agreement and the rules, standards, and policies set from time to time by Domino's in its sole and exclusive discretion.

NOW THEREFORE, in consideration of the premises, the mutual promises contained herein, and other good and valuable consideration, receipt of which is hereby acknowledged, the parties agree as follows:

1. Term; Termination

1.1 The term of the Agreement shall commence upon acceptance of this Agreement by Domino's at its offices in Ann Arbor, Michigan, and unless terminated sooner as set forth below, shall remain in force for a period of three years (the "Original Term"). At the end of the Original Term, this Agreement shall automatically renew for successive one year terms (each, a "Renewal Term"), unless terminated sooner by either party as set forth below.

1.2 Either party may terminate this Agreement at any time and for any or no reason by providing written notice to the other party.

1.3 This Agreement shall terminate immediately upon: (a) Franchisee's bankruptcy or insolvency; (b) the cessation of Franchisee's business operations as a Domino's franchisee or the termination or non-renewal of the Standard Franchise Agreement for the Store; (c) the cessation of Franchisee's use of Domino's approved point-of-sale system or OLO; or (d) for the reasons set forth below in Section 3.2.

1.4 Upon termination of this Agreement, Franchisee shall immediately terminate the use of the Platform. The ownership rights provisions in Section 3 of this Agreement, the confidentiality provisions in Section 7.8, and the limitation of liability and indemnification provisions in Section 4, shall survive any expiration or termination of this Agreement.

2. Fees and Charges

Domino's is not requiring Franchisee to pay a Service Fee for its utilization of the Platform. Franchisee is solely responsible for providing any equipment, reimbursement, or payment that may be necessary to utilize the Platform. Franchisee is solely responsible for determining the equipment to be used in its Stores as well as any reimbursement or payment to be issued by Franchisee to its employees and any vendors or third parties for use of the equipment or utilization of the Platform.

3. Ownership Rights

3.1 All rights to patents, copyrights, trademarks, and trade secrets in the Platform or any modifications shall remain with Domino's and/or its affiliates or with the respective manufacturer or author.

3.2 Domino's may immediately terminate this Agreement in the event Franchisee violates or infringes on the intellectual property rights of another with respect to the Platform or challenges the ownership rights as set forth in section 3.1.

4. Limitation of Liability and Indemnification

FRANCHISEE ASSUMES TOTAL RESPONSIBILITY FOR THE USE OF THE PLATFORM, AND THE PLATFORM IS PROVIDED ON AN "AS-IS" BASIS. TO THE MAXIMUM EXTENT PERMITTED BY LAW, THE PLATFORM IS PROVIDED WITHOUT WARRANTIES OF ANY KIND, EITHER EXPRESS OR IMPLIED, AND WHETHER ARISING UNDER LAW OR FROM COURSE OF PERFORMANCE, COURSE OF DEALING, OR USAGE OF TRADE (COLLECTIVELY, "DISCLAIMED WARRANTIES") INCLUDING, WITHOUT LIMITATION, ANY WARRANTIES

OF NON-INFRINGEMENT, MERCHANTABILITY, OR FITNESS FOR A PARTICULAR PURPOSE. ALL SUCH WARRANTIES ARE HEREBY EXPRESSLY EXCLUDED BY DOMINO'S AND FOREVER WAIVED BY FRANCHISEE. NO ADVICE OR INFORMATION GIVEN BY DOMINO'S, ITS AFFILIATES, ITS SUBSIDIARIES, OR ITS CONTRACTORS OR THEIR RESPECTIVE EMPLOYEES SHALL CREATE A WARRANTY OR OBLIGATION OF DOMINO'S. In the event that any of the Disclaimed Warranties cannot be disclaimed or waived under applicable law, Franchisee's sole and exclusive remedy for breach of such Disclaimed Warranty will be the replacement of the Platform, at no additional cost to Franchisee.

Franchisee expressly acknowledges and agrees that neither Domino's nor any of its affiliates shall have any liability whatsoever under this Agreement for any damages that Franchisee may allege are caused by the use of the Platform or that Franchisee may allege were not prevented by the use of the Platform including, but not limited to, special, indirect, consequential, incidental, punitive, loss of profits, or exemplary damages under any circumstances, whether based on tort or breach of contract claims or on any other basis, even if Domino's has been advised of the possibility of such damages. Franchisee further acknowledges and agrees that neither Domino's nor its affiliates are as a principal or primary business engaged in providing the services offered as part of the Program to third parties, and have offered Franchisee the opportunity to utilize the Platform expressly conditioned on Franchisee's acceptance of all of the caveats and disclaimers of liability set forth herein. Franchisee's sole and exclusive remedy for any dissatisfaction with, or harm allegedly caused by, the Platform shall be the termination of this Agreement. Franchisee also agrees to defend, indemnify, and hold harmless Domino's and its subsidiary or affiliated companies or any of its or their agents or employees, from and against any losses, damages, liabilities, injuries, claims, suits, judgments, causes of action, costs and expenses (including, without limitation, attorneys' fees and costs) arising from or relating to: (a) a breach of any obligation, representation, or warranty of Franchisee under this Agreement; (b) any act or omission by Franchisee, its employees, agents, representatives, or contributors in the performance of this Agreement including, but not limited to, those acts or omissions that constitute negligence, recklessness, or intentional/willful misconduct; (c) the loss of sales, customers, or any decrease in revenue or profitability of Franchisee's Stores; or (d) any allegation or claim brought by a third party that Franchisee's use of the Platform infringes the intellectual property rights of any third party.

In addition to Franchisee's indemnification obligations under the Standard Franchise Agreement, Franchisee agrees to the following indemnification obligation set forth below. If Domino's or its subsidiary or affiliated companies or any of its or their agents or employees are required to produce records or testify at trial or in deposition or are subjected to any claim, demand, or penalty, or become a party to any suit or other judicial or administrative proceeding brought by any person(s) (including Franchisee's employee(s) or prior employee(s)) or any other person or entity by reason of any claimed act or omission by Franchisee, its employees or agents, or by reason of Franchisee's or its employees' or agents' utilization of the Platform, Franchisee shall defend and indemnify and hold Domino's, its subsidiary and affiliated companies, or any of its or their agents or employees, harmless against all judgments, settlements, penalties, and expenses, including attorney's fees, court costs, and other expenses of litigation or administrative proceeding, incurred by or imposed on Domino's, its subsidiary and affiliated companies, or any of its or their agents or employees, in connection with the testimony, production, investigation, or defense relating to such claim, litigation, or administrative proceeding. Franchisee's indemnification obligations described above will continue in full force and effect after, and notwithstanding, the expiration or termination of this Agreement or the Standard Franchise Agreement.

5. Franchisee Platform Data

Franchisee agrees that Domino's may, at any time, have full access, both on-site and from a remote location, to all of Franchisee's computer data, equipment and systems containing any and all of the information, records and reports relating to the Platform and to use the data in the evaluation of the Platform. Domino's may retain a copy or a complete backup on its system of any data it has access to pursuant to this Agreement. Domino's will use the same degree of care to protect against unauthorized use of the information by third parties as it does with respect to its own information of a similar type. For the avoidance of doubt, any data accessed by Domino's shall remain the property of Franchisee as a data controller and any use of the data by Domino's shall be solely in its capacity as a data processor.

6. Compliance with Laws

Franchisee agrees to comply with all applicable federal, state, and local laws, statutes, codes, ordinances, regulations, rules, and common law related to its use of the Platform including, but not limited to, those related to the use, monitoring, collection, and retention of GPS location and other information, the safe use of the Platform, any reimbursement or payment to its employees, and the tax treatment of any reimbursement or payment to its employees. Franchisee agrees to consult its own legal counsel to ensure compliance with all applicable federal, state, and local laws, statutes, codes, ordinances, regulations, rules, and common law.

Franchisee agrees to provide sufficient notices to its employees utilizing the Platform, including the Driver App, in its Stores and to obtain and retain all acknowledgements and consents from its employees as may be necessary including, at minimum, authorization for the use of GPS location-tracking capabilities and the collection and monitoring of GPS location and other information associated with the Driver App by customers, Franchisee, Domino's, and each of their affiliates, vendors, personnel, and all other entities involved in any way with utilization of the Platform and/or the location-tracking of deliveries.

7. General

7.1 This Agreement constitutes a complete integration and the entire agreement between the parties relating to the Platform. This Agreement supersedes all prior representations, discussions, and communications, whether oral or written, between the parties relating to the Platform, and there are no understandings or agreements relating to the Platform other than those expressed in this Agreement. This Agreement may be modified only in a writing signed by an authorized representative of each party.

7.2 Neither party shall be liable for delays in any of its performance hereunder due to causes beyond its reasonable control including, but not limited to, acts of God, strikes, or inability to maintain labor or materials on time.

7.3 If any provision of this Agreement shall be deemed illegal or otherwise unenforceable, that portion shall be severed and the remainder of this Agreement shall remain in full force and effect. A waiver shall be effective only if made in writing and signed by an authorized representative of both parties. The waiver of any right or election of any remedy in one instance shall not affect any rights or remedies in another instance.

7.4 All required notices under this Agreement shall be sent to the recipient party's address. All notices shall be given by certified or registered mail, or overnight carrier. Such notices shall be deemed given on the date of receipt (or refusal) of delivery of said notice.

If to Domino's: Domino's Pizza Distribution LLC
 24 Frank Lloyd Wright Drive
 P.O. Box 485
 Ann Arbor, MI 48106

If to Franchisee, to the most current business address provided by Franchisee to Domino's in writing.

7.5 This Agreement shall be governed by the laws of the State of Michigan.

7.6 Neither party to this Agreement is, or shall represent itself to be, an agent, partner, or employee of the other. Nothing in this Agreement shall be interpreted or construed as creating or establishing a joint venture, agency, or partnership, or any relationship other than independent parties to a contract. Each party retains control of the day-to-day activities of its respective business. As an independent business owner, Franchisee remains solely responsible for the persons who work in its Stores and those persons are Franchisee's employees, and not employees of Domino's. Franchisee is solely responsible for any training to be provided to its employees regarding the Platform.

7.7 Franchisee acknowledges that during the term of this Agreement, it may obtain access to confidential and proprietary information, trade secrets, and financial information (the "Confidential Information") relating to the Platform. Franchisee acknowledges that Domino's would be irreparably damaged by the disclosure of the Confidential Information to others. Therefore, Franchisee agrees to keep secret and confidential and not to disclose the Confidential Information of Domino's relating to the Platform without the prior written consent of Domino's. The agreement not to disclose the Confidential Information shall survive the expiration or termination of this Agreement.

IN WITNESS WHEREOF, the parties have caused this Agreement to be executed.

Domino's Pizza Distribution LLC

**Controlling Owner (individually and for all
business entities owned by the Controlling
Owner):**

By: _____

By: _____

Its: _____

Fcode: _____

Date: _____

Date: _____

EXHIBIT S

DOMINO'S RIDER TO SERVICES AGREEMENT

Domino's® Rider to Services Agreement

THIS RIDER TO SERVICES AGREEMENT (the "Rider") is made this ___ day of _____, 20___, by and between _____ ("Client") and _____ ("Vendor").

WHEREAS, Client, a franchisee of Domino's Pizza Franchising LLC ("DPF"), and Vendor have entered into a services agreement dated _____, 20__ for the provision of specific services (the "Agreement"); and

WHEREAS, in order for Client to comply with the terms and conditions of its contractual obligations to DPF, and in order for Vendor to be approved by DPF to provide the services contemplated in the Agreement to a franchisee of DPF, Client and Vendor are required to execute this Rider that will serve to modify the Agreement:

NOW, THEREFORE, the parties agree as follows:

1. **Inconsistency between the Agreement and Rider.** In the event of any inconsistency between the terms of the Agreement and this Rider, the terms of this Rider shall prevail.
2. **Information Security Audit.** Prior to performing any services for Client or gaining access to any customer order data (e.g., customer name, customer contact details, customer delivery address, order details, etc.) and summaries thereof and/or confidential or proprietary business information of the Domino's brand or franchisee's business (individually and collectively, "Confidential Information"), Vendor must first be approved (and shall not have been subsequently disapproved) by the Information Security Team of Domino's Pizza LLC ("DPL") as a vendor of the services to be provided to the Client under the Agreement to ensure that the Vendor meets the physical, logical, and contractual security requirements established and updated by DPL from time to time with respect to both data security and data privacy. As a condition to Vendor maintaining its status as an approved supplier of such services, Vendor must take the requisite steps to ensure that any subcontractor to the Vendor with access to such Confidential Information meets the same or substantially similar physical, logical, and contractual security requirements established by DPL from time to time with respect to both data security and data privacy and such subcontractor shall provide any required or requested supporting documentation (e.g. SOC 2, AOC, evidence of an external scan, etc.). Vendor shall fully cooperate with such assessment by providing access to knowledgeable personnel, documentation, infrastructure and application software that processes, stores or transports customer order data, Confidential Information for Client and DPL pursuant to this Agreement. DPL reserves the right to charge Vendor its then current fee for performing such Information Security audits of Vendor to account for the time and resources of the Information Security Team, which fee shall be due and paid by Vendor to DPL within thirty (30) days of receipt of an invoice. Furthermore, Vendor shall, on an annual basis, conduct an internal, data security risk assessment and implement reasonable administrative, technical, and physical safeguards designed to protect the Client's customer order data and Confidential Information from unauthorized disclosure. Upon request by the Client, Vendor agrees to provide documentation sufficient to demonstrate Vendor's compliance with the terms of this paragraph and any applicable privacy and security requirements. In addition, upon Client's request, Vendor shall provide Client with the results of any audit performed by or on behalf of Vendor that assesses the effectiveness of Vendor's information security program as relevant to the security and confidentiality of customer order data and Confidential Information shared during the course of this Agreement.
3. **Compliance with Laws.** Vendor will comply with all applicable laws, rules, regulations or ordinances applicable to its performance under this Agreement. Inclusive in this obligation shall be Vendor's representation and warranty that, if the Vendor is collecting or gaining access to customer credit card data, that it is and will remain in compliance with the applicable Payment Card Industry Standards ("PCI"), including, but not limited to, the Payment Card Industry Data Security Standard ("PCI-DSS") throughout the term of the Agreement.

4. **Breach Notification Obligations.** Vendor agrees to provide written notice to the Client's senior management and DPL within 24 hours of becoming aware of any fact or circumstances that cause the Vendor to suspect that any data (including, but not limited to, customer order data) or Confidential Information may have been wrongfully accessed, which notification shall include a description of the volume and types of the data and Confidential Information it suspects may have been wrongfully accessed, in addition to the facts and circumstances that has lead the Vendor to suspect the existence of a breach. In addition to the notice requirements set forth in the Agreement, Vendor agrees to provide notice of any breach notification to DPL and DPF in writing at the following address: 30 Frank Lloyd Wright Drive, Ann Arbor, Michigan, 48106, Attention: Vice President of Information Security, with a copy to the Office of the General Counsel. Furthermore, Vendor shall comply with any applicable breach notification laws and obligations that it may be subject to in the event of such an incident and shall cooperate with Client and DPL in conjunction with any obligations they may have as a result of such breach.
5. **Indemnification.** Vendor shall indemnify, defend and hold Client, DPL, DPF and each of their respective affiliates, and each of their respective officers, directors, employees and agents, harmless from and against any losses, damages, liabilities, injuries, claims, suits, judgments, causes of action and expenses, including attorneys' fees, suffered or incurred by any of them arising from or relating to (i) a breach of any obligation, representation or warranty of Vendor hereunder, (ii) any act or omission by Vendor, its employees, agents, subcontractors, representatives or contributors in the performance of this Agreement, (iii) any claim brought by a third party that work performed or services provided by Vendor under this Agreement infringes any patent, copyright, trade secret or other intellectual property right of any third party, and (iv) any data security incidents that may result in the unauthorized disclosure of any customer order data, Confidential Information of Client or provided by Client under this Agreement that occur while such information is in the care, custody or control of Vendor or its subcontractors.
6. **Insurance.** Vendor shall maintain the following types and amounts of insurance coverage with an insurance company rated "A" or better in A.M. Best & Co.:
- Commercial General Liability Insurance with a limit of at least \$1,000,000 per each claim and \$1,000,000 annual aggregate.
 - Errors and Omissions or Professional Liability Insurance coverage with a limit of at least \$1,000,000 per each claim and \$1,000,000 annual aggregate. This coverage should include infringement of copyright, trademark, title or slogan, piracy, plagiarism or unauthorized use of materials.
 - Cyber-Liability Insurance with a limit of at least \$1,000,000 per each claim and \$1,000,000 annual aggregate.
- Vendor shall ensure that all certificates for coverage under such commercial general liability, errors and omissions or professional liability, cyber-liability, and any other coverage required by DPL or under local law, shall: (i) name Client, DPL, DPF, and their respective affiliates as an additional insured, including without limitation, as an insured with respect to third-party claims or actions made or brought directly against Client and Vendor as co-defendants and arising out of or in connection with this Agreement; (ii) be written as a primary policy not contributing with any other coverage which Client may carry; and (iii) stipulate that Client and DPL shall receive thirty (30) days' prior written notice of any cancellation or reduction in coverage; provided that such cancellation or alteration shall not relieve Vendor of its continuing obligation to maintain insurance coverage in accordance with this Section.
7. **Usage of Customer Order Data and Confidential Information.** Vendor shall only process customer order data and Confidential Information in strict compliance with the direction and instructions of the Client. Vendor shall be prohibited from using the customer order data (e.g., customer name, customer contact details, customer delivery address, order details, etc.) and summaries thereof or any Confidential

Information collected during the order taking process or accessed and received in the provision of services for themselves or selling or otherwise providing it to any third-party during or after the term of this Agreement. Upon the conclusion or termination of the relationship with Client, Vendor shall return any customer order data or Confidential Information in their possession to Client (or purge and destroy the customer order data or Confidential Information if requested by Client or DPL and provide certification of such destruction). For the avoidance of doubt, Vendor shall be restricted from using any of any customer order data, including in an aggregated and de-identified format, for any purpose without the prior written consent of Client, which consent may be withheld in its sole discretion. This restriction on use of customer order data includes, but is not limited to, use for artificial intelligence or machine learning or for otherwise augmenting or creating its own database. For the avoidance of doubt, Vendor may retain copies of Confidential Information that are stored on Vendor’s information technology backup and disaster recovery systems until the ordinary course deletion thereof (it being understood that any Confidential Information so retained is subject to the terms of this Agreement).

8. **Third-Party Beneficiary.** Vendor acknowledges and agrees that while neither DPF nor DPL are parties to the Agreement, they are each intended to be third-party beneficiaries of the rights set forth in this Rider, and shall have the right to take legal action in their own name, with our without the involvement of Client, to enforce their rights and the obligations Vendor under this Rider and the Agreement.

IN WITNESS WHEREOF, the parties have executed this Rider on or as of the date first above written.

Vendor:

Client:

Print "Company Name" Above

Print "Company Name" Above

By: Signature

By: Signature

(Print "Name" Above)

(Print "Name" Above)

Its: *(Print "Title" Above)*

Its: *(Print "Title" Above)*

State Effective Dates

The following states have franchise laws that require that the Franchise Disclosure Document be registered or filed with the state, or be exempt from registration: California, Hawaii, Illinois, Indiana, Maryland, Michigan, Minnesota, New York, North Dakota, Rhode Island, South Dakota, Virginia, Washington, and Wisconsin.

This document is effective and may be used in the following states, where the document is filed, registered or exempt from registration, as of the Effective Date stated below:

State	Effective Date
California	April 1, 2024 (Exempt)
Hawaii	April 5, 2024
Illinois	April 1, 2024 (Exempt)
Indiana	April 1, 2024 (Exempt)
Maryland	April 2, 2024 (Exempt)
Michigan	March 29, 2024
Minnesota	April 9, 2024, as amended _____
New York	April 1, 2024 (Exempt)
North Dakota	April 3, 2024 (Exempt)
Rhode Island	April 4, 2024 (Exempt)
South Dakota	March 29, 2024
Virginia	April 4, 2024 (Exempt), as amended _____
Washington	March 28, 2024 (Exempt), as amended _____
Wisconsin	March 29, 2024

Other states may require registration, filing, or exemption of a franchise under other laws, such as those that regulate the offer and sale of business opportunities or seller-assisted marketing plans.

RECEIPT

This disclosure document summarizes certain provisions of the franchise agreement and other information in plain language. Read this disclosure document and all agreements carefully.

If Domino's Pizza Franchising LLC ("DPF") offers you a franchise, it must provide this disclosure document to you ten business days before you sign a binding agreement with, or make a payment to, the franchisor or an affiliate in connection with the proposed franchise sale. [However, some state franchise laws require that DPF provide this disclosure document to you at the first personal meeting held to discuss the franchise sale].

If DPF does not deliver this disclosure document on time or it contains a false or misleading statement, or a material omission, a violation of federal and state law may have occurred and should be reported to the Federal Trade Commission Washington, D. C. 20580 and your respective state agency.

The name, principal business address and telephone number of each franchise seller is as follows:

Colleen McCormick, Sr. Manager – Regulatory Affairs and Contracts, Dominos' Pizza Franchising LLC, 24 Frank Lloyd Wright Drive, Ann Arbor, Michigan 48105-9484, (734) 930-3030.

Issuance Date: April 1, 2024, as amended July 31, 2024.

We authorize the respective state agencies identified on Exhibit A to receive service of process for DPF in the particular state. I have received a Disclosure Document dated April 1, 2024, as amended July 31, 2024. (For state-specific effective dates, see Exhibit A of this disclosure document) that included the following Exhibits:

- A List of State Agencies/Agents for Service of Process
- B List of Domino's Pizza Franchisees
- B-1 List of Domino's Pizza Non-Traditional Franchisees
- B-2 List of Franchisees Who Have Left the System
- C Domino's Pizza Franchising LLC Financial Statements
- D Domino's Pizza LLC Financial Statements
- E Standard Franchise Agreement
- F Non-Traditional Store Franchise Agreement
- G Development Agreement
- H Domino's Pizza Help Desk Services Agreement
- I Sale of Assets Agreement
- J Domino's PULSE Software License Agreement
- K Expiration of Franchise Agreement and Release
- L Rider to Lease
- M Rider to Purchase Agreement
- N Operating Manual Table of Contents
- O Application for Franchise (Renewal)
- P Domino's Pizza Online Ordering Franchisee Services Agreement
- Q Term Sheet
- R Global Positioning System Technology Platform Agreement
- S Domino's Rider to Services Agreement

Date

Printed Name

Signature

RECEIPT

This disclosure document summarizes certain provisions of the franchise agreement and other information in plain language. Read this disclosure document and all agreements carefully.

If Domino's Pizza Franchising LLC ("DPF") offers you a franchise, it must provide this disclosure document to you ten business days before you sign a binding agreement with, or make a payment to, the franchisor or an affiliate in connection with the proposed franchise sale. [However, some state franchise laws require that DPF provide this disclosure document to you at the first personal meeting held to discuss the franchise sale].

If DPF does not deliver this disclosure document on time or it contains a false or misleading statement, or a material omission, a violation of federal and state law may have occurred and should be reported to the Federal Trade Commission Washington, D. C. 20580 and your respective state agency.

The name, principal business address and telephone number of each franchise seller is as follows:

Colleen McCormick, Sr. Manager – Regulatory Affairs and Contracts, Dominos' Pizza Franchising LLC, 24 Frank Lloyd Wright Drive, Ann Arbor, Michigan 48105-9484, (734) 930-3030.

Issuance Date: April 1, 2024, as amended July 31, 2024.

We authorize the respective state agencies identified on Exhibit A to receive service of process for DPF in the particular state. I have received a Disclosure Document dated April 1, 2024, as amended July 31, 2024. (For state-specific effective dates, see Exhibit A of this disclosure document) that included the following Exhibits:

- A List of State Agencies/Agents for Service of Process
- B List of Domino's Pizza Franchisees
- B-1 List of Domino's Pizza Non-Traditional Franchisees
- B-2 List of Franchisees Who Have Left the System
- C Domino's Pizza Franchising LLC Financial Statements
- D Domino's Pizza LLC Financial Statements
- E Standard Franchise Agreement
- F Non-Traditional Store Franchise Agreement
- G Development Agreement
- H Domino's Pizza Help Desk Services Agreement
- I Sale of Assets Agreement
- J Domino's PULSE Software License Agreement
- K Expiration of Franchise Agreement and Release
- L Rider to Lease
- M Rider to Purchase Agreement
- N Operating Manual Table of Contents
- O Application for Franchise (Renewal)
- P Domino's Pizza Online Ordering Franchisee Services Agreement
- Q Term Sheet
- R Global Positioning System Technology Platform Agreement
- S Domino's Rider to Services Agreement

Date

Printed Name

Signature