



BD 微電腦快速乾燥機

BD Microprocessor Controlled High Speed Dryer



BD 微電腦快速乾燥機適用如下:

1. 射出量大的生產
2. 押出量大的生產
3. 經常性換料生產



BD microprocessor controlled high speed dryer is suitable for below items.

1. Big injection molding production.
2. Big extruding production.
3. Frequently changing plastic production

BD 乾燥機系列-結構

BD Dryer Series- Structure

空氣噴槍
Air spray gun

空氣濾清器
Air Filter

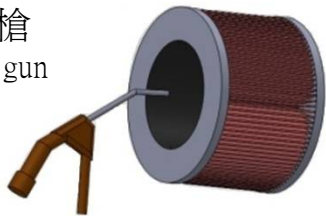

警報響起，請用空氣噴槍清潔空氣濾清器即可。

Alarm will be buzzing, please use air spray gun to clean air filter.

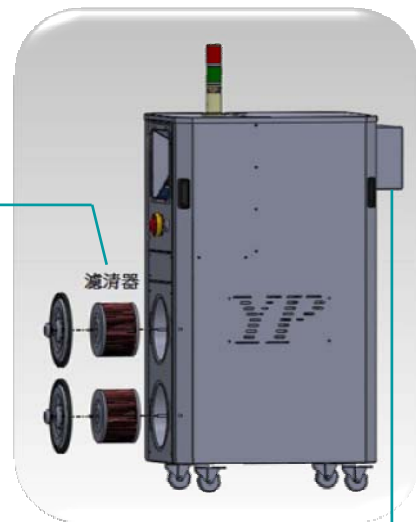

乾燥的風送至料桶
Drying wind send to hopper.

雜質和潮溼的風送至集塵器
Impurities and moist wind send to dust collector.

此為集塵器，用來收集料桶所排出的雜質
This is dust collector. In to order to collect impurities which discharged from hopper.

閘門 Switch

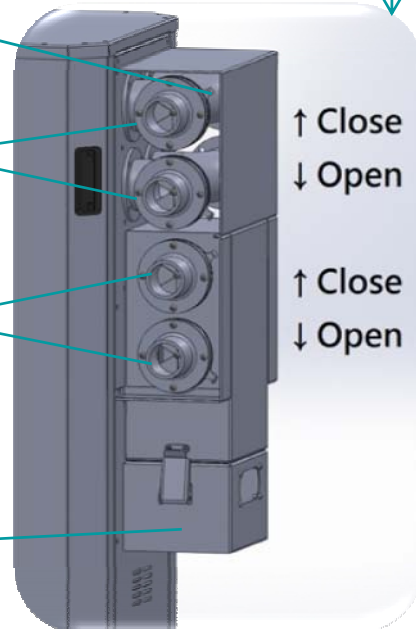

關閉

關閉

BD乾燥機系列-示意圖

BD dryer Series-Schematic diagram

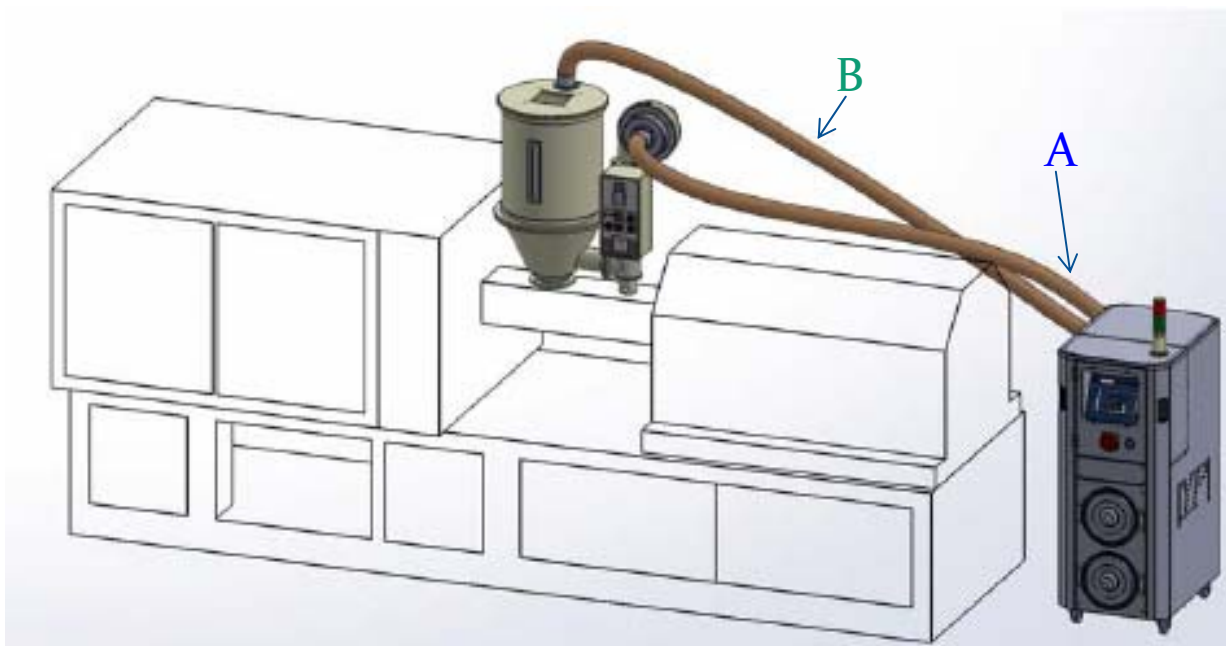

A: YP乾燥機送乾燥的風送至料桶中
A: YP dryer send drying wind into hopper.

B: 雜質和含有濕度的空氣送入集塵盒中
B: Impurities and air of comprising humidity send into dust collector.

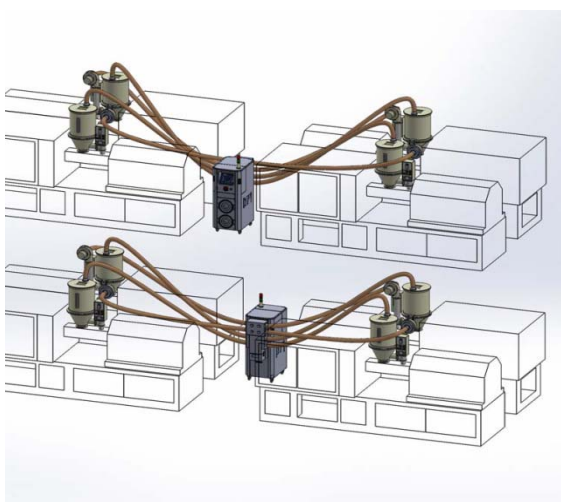

1台BD系列乾燥機可連1~4料桶
One HS series dryer could connect 1~4 hoppers.

YP 快速乾燥機適用在各種射出機或押出機上
YP high speed dryer is suitable for all kinds of injection molding machine or extruder machine.



BD 微電腦快速乾燥機規格表 BD Microprocessor Controlled High Speed Dryer Specification

| 型式 Model | HS-025BD | HS-050BD | HS-100BD | HS-200BD | HS-400BD | HS-600BD | HS-800BD | |
|-------------------------------------|-------------|----------|----------|----------|----------|----------|----------|------|
| 乾燥風量 (m3/hr) Drying wind rate | 45 | 60 | 120 | 220 | 460 | 585 | 850 | |
| 總瓦特數 (kw) Total wattage | 2.59 | 3.20 | 4.25 | 6.40 | 10.60 | 14.60 | 16.60 | |
| 尺寸 Size (mm) | 寬度 Width | 510 | 510 | 535 | 561 | 612 | 637 | 637 |
| | 深度 Depth | 869 | 869 | 958 | 993 | 1062 | 1096 | 1116 |
| | 高度 High | 1515 | 1515 | 1573 | 1631 | 1747 | 1805 | 1805 |
| 重量 Weight(kg) | 110 | 130 | 185 | 236 | 381 | 420 | 547 | |

*此機台為連續式適用於所有塑料、生產用、實驗室

*This machine is continuous and suitable for all plastics ,production, and laboratory.



YP 快速乾燥機

YP High Speed Dryer

| | |
|----|-------------|
| 省錢 | Save Money |
| 快速 | High Speed |
| 節能 | Save Energy |

燁品企業有限公司
電話 :+886-3-409-0577
傳真 :+886-3-409-3381
網址 :www.ye-pin.com.tw
國內聯絡e-mail : yepin.com@msa.hinet.net
國外聯絡e-mail : jenny_lo@ye-pin.com.tw

YE PIN CO., LTD.
TEL:+886-3-409-0577
FAX:+886-3-409-3381
Website :www.ye-pin.com.tw
Domestic contact e-mail: yepin.com@msa.hinet.net
Foreign contact e-mail: jenny_lo@ye-pin.com.tw