



FUTURE

of Architectural Research

ARCHITECTURAL
RESEARCH CENTERS
CONSORTIUM 2015

Editors:

Ajla Aksamija

John Haymaker

Abbas Aminmansour

/// FUTURE of Architectural Research

Proceedings of the ARCC 2015 Conference
Architectural Research Centers Consortium
FUTURE of Architectural Research

Editors: Ajla Aksamija, John Haymaker, Abbas Aminmansour
Graphic design: Ajla Aksamija
Editorial assistance: Yi Wang and Thomas Forker
Publisher: Perkins+Will

ISBN 978-0-9847582-0-3

PERKINS+WILL

UMassAmherst

© 2015 All Rights Reserved. Authors retain copyright for individual articles, and are solely responsible for their content.
No part of this book may be reproduced in any manner without prior written permission from the publisher.



FUTURE
of Architectural Research

Editors:
Ajla Aksamija
John Haymaker
Abbas Aminmansour

TABLE OF CONTENTS

ARCC 2015 Conference Organizing Committee and Technical Committee	i
Introduction	ii
Advanced Materials and Building Technologies	
<i>Adaptive Efficiencies: Responding to Change through Anticipatory Prefabricated Design</i> , Charlotte Styer	12
<i>Apples to Oranges: A Tool for Comparing Building Materials</i> , Liane Hancock	20
<i>Assessment of Annual Energy Enhancement for Tall Building Integrated Wind Turbines (BIWT)</i> , Farid Abdolhossein Pour, Matthew Herman and Robert Krawczyk	28
<i>Bamboo-Steel Composite Structures</i> , Rui Liu and Yushun Li	37
<i>Bi-Directional Thermo-Hygroscopic Facades: Feasibility for Liquid Desiccant Thermal Walls to Provide Cooling in a Small Office Building</i> , Marionyt Marshall	45
<i>Design for Future Structural Adaptability</i> , Hollee Becker	57
<i>Fusing Design and Construction through Potential Articulations within the Built Environment</i> , Stig Nielsen and Alexandru Dancu	65
<i>Natural Building: The Viability of Straw Bale as a Sustainable Model for Future Development</i> , Arsenio Rodrigues	74
<i>Surveying Stereotomy: Investigations in Arches, Vaults and Digital Stone Masonry</i> , Shayani Fernando, Rob Saunders and Simon Weir	82
<i>The Significance of Nanotechnology in Architectural Design</i> , Ming Hu	90
<i>Towards Digital Containerized Factories of Composite Architectural Panels for Complex Shaped Buildings</i> , Daniel Chung and Kihong Ku	97
<i>Education Buildings and the Potential to Become Net-Zero Energy Buildings</i> , Aydin Tabrizi and Paola Sanguinetti	104
Environmental, Energy and Building Performance Factors	
<i>A Decision-Making Framework for Optimizing Roof Functionality in Sustainable Buildings</i> , Nooshafarin Mohammadzadeh, Nikita Jathan and Soolyeon Cho	117
<i>A Design Decision Support Tool for Visual Comfort Evaluation under Daylighting Conditions</i> , Dalia Hafiz	126
<i>A Tale of Three Zones</i> , Courtney Goertz, Andrea Calhoun, Garrett Watkins and Alison Kwok	133
<i>Analyzing the Retrofit Potential of Historic Homes in Hot-Humid Climates</i> , Hazem Rashed-Ali, William Dupont, Randall Manteufel and Thomas Thomson	141
<i>Bridging the Gap: Supporting Data Transparency from BIM to BEM</i> , Mohammed Hijazi, Karen Kensek and Kyle Konis	149
<i>Building Performance Analysis Considering Climate Change</i> , Yiyu Chen, Karen Kensek, Joon-Ho Choi and Marc Schiler	167

<i>Climate-Responsive Evidence-Based Green-Roof Design Decision Support for the U.S. Climate,</i> Spurthy Yogananda, Joon Ho Choi and Doulas Nobles	165
<i>Energy Performance and Community Resiliency: A Review of Housing Policy and Programs,</i> Lisa Iulo and Kaitlin O'Brien	174
<i>Is Naturalness of Elementary School Sites Linked to Student's Academic Performance and Health?</i> Muntazar Monsur and Ozlem Demir	183
<i>Life Cycle Assessment of Urban vs. Suburban Residential Mobility in Chicago,</i> Peng Du	188
<i>Method for Estimating Energy Use Intensity Based on Building Façade Features,</i> Chao Yang and Joon-Ho Choi	196
<i>Morphometric Analysis of Daylight Factor, Kairouan Mosque Case,</i> Sonda Ben Amor and Abdelkader Ben Saci	205
<i>Negative Life-Cycle Emissions Growth Rate through Retrofit of Existing Institutional Buildings,</i> Somayeh Tabatabaee, Benjamin Weil and Ajla Aksamija	212
<i>Net-Zero Energy Retrofits for Commercial Buildings,</i> Yi Wang and Ajla Aksamija	222
<i>Net-Zero Lessons for Architectural Design Education,</i> Mary Guzowski	231
<i>Passive House Informed: The Next Level of Energy Efficiency in Affordable Housing,</i> Amanda Donofrio, Mike Magee and Julie Romig	239
<i>Quantifying the Impact of Passive Design on High-Rise Buildings,</i> Mohamed Krem, Simi Hoque and Sanjay Arwade	246
<i>Representing Complexity: Understanding Performance in Integrated Design,</i> Clifton Fordham	255
<i>The Potential of Predictive Modeling and Automated Building Facade Elements to Attain Thermal Comfort,</i> Troy Peters	263
<i>Urban Climate Change Impacts on Building Heating and Cooling Energy Demand,</i> Pravin Bhiwapurkar	270
Computational Design	
<i>A Practical Optimization Method for Choosing Energy and Cost Efficient Massing, Materials and Technologies for a Building Design,</i> Sandeep Ahuja, Patrick Chopson, John Haymaker and Godfried Augenbroe	280
<i>Another Approach to Space,</i> Dennis Lagemann	288
<i>Building without Nails: Enabling Flexibility and Structural Integrity through Dgital Prototyping,</i> Basem Eid Basem Eid Mohamed, Frederic Gemme and Aaron Sprecher	296
<i>Computational Landscape: Data Driven Urban Modeling with Agent-Based System,</i> Ming Tang	303
<i>Evolutionary Parametric Analysis for Optimizing Spatial Adjacencies: A Generative Tool for Architectural Programming,</i> Christopher Boon, Corey Griffin, Nicholas Papaefthimiou, Jonah Ross and Kip Storey	312
<i>Leveraging Data in Academia and Practice: Geometry, Human- and Building-Performance,</i> Randall Deutsch	320
<i>Toward Optimization and Performance: Assessing Architectural Design through the Integration of Responsive Microcontroller Technologies,</i> Pasquale De Paola	326
<i>Wicked Tactics - UX/XD: World-Building in Post-Virtual Space,</i> Heather Barker	332

Social and Behavioral Research

<i>Analysis of Low-Energy Envelope and Lighting Measures for Single-Family Dwellings in the West Indies,</i> Cynthia Wilson and Hyojin Kim	342
<i>Changing the Agent of Change: POEs for Greater Aesthetic and Scientific Data Collection,</i> Glenn Nowak and Talah Pejooch	351
<i>Constructing Creativity: Investigating the Types of Environments Preferred for a Range of Work Tasks,</i> Giancarlo Mangone, Henk Staats and Peter Luscuere	356
<i>Core-Housing and Collaborative Architecture: Learning from Dandora,</i> Glen Wash Ivanovic and Junko Tamura	363
<i>Semi-Immersive Virtual Environment Preference Study of Four Interior Architectural Geometries,</i> Hannah Hobbs, Kurt Hunker, Vuslat Demircay, Tiffany Rodriguez and Rajaa Issa	369
<i>Sound Design Intervention in an Open Studio: Linking Behaviour, Spatial and Acoustic Analysis,</i> Aaron Michelle Baker	377

Building Types and Design Methods

<i>A Holistic Approach to Urban and Architectural Design with Housing Sustainability Paramount,</i> Sara Alinaghi Pour and Brian Sinclair	386
<i>Building Tall in the Arabian Gulf: Perception Performance Place-Making,</i> Fahad Alotaibi and Brian Sinclair	395
<i>Contextual Fields: Design Methods in the Construction of Lever House,</i> Robert Holton	404
<i>Dutch Complex Housing: Design for Density,</i> Julia Robinson	412
<i>Effectiveness of Design Standards in Improving Residence Hall Usability and Satisfaction,</i> Edward Steinfeld, Sue Weidemann, Jonathan White and Elyse Skerker Sigal	420
<i>Fast Housing in the U.S.,</i> Lisa Tucker	426
<i>Environmental Measurements of Classrooms at the Florida A and M University,</i> Sang Bum Park, Ronald Lumpkin, Kathie Laurent and Khari Peart	434
<i>A Parametric Metamorphosis of Islamic Geometric Patterns: The Extraction of New from Traditional,</i> Mostafa Alani and Carlos Barrios	442
<i>Method and the Absence of Modernism,</i> Philip Plowright	450
<i>Neither Here nor There: Housing Americans in the Italian Countryside,</i> Christina Bollo	458
<i>Recycle as Architectural Cre-a[c]tive Strategy,</i> Moira Valeri	465
<i>Sensory Informed Design: Human Processes and Emerging Sensory Tools,</i> Diana Nicholas, James Connell and Jennifer Plumb	472
<i>Size Matters in Housing Design,</i> Christina Bollo	480
<i>The New Factory, the New City, and an Expanded Idea of Urban Ecology,</i> Howard Davis	485
<i>Therapeutic Dimensions of Palliative Care Environment,</i> Sharmin Kader and Keith Diaz Moore	492
<i>Urban Healthcare,</i> Kevin Moore and Christian Dagg	500

Research in Practice

<i>A Comparative Approach to Map BIM Workflow in US Mid-Size Firms Using BPMN and IDEF Methods,</i> Ibrahim Abdelhady	509
<i>Designing Adaptability in Practice: Causes and Consequences,</i> George Guy and Margherita Pongiglion	517
<i>Designed for Performance: A Collaborative Research Studio Rethinks the Environmental Integration, Materiality, and Manufacturing of Curtain Wall Systems,</i> Michael Gibson	525
<i>RTKL's Performance Driven Design: Lessons Learned from the Commercial Practice,</i> Pablo La Roche	536
<i>A Methodology of Building Performance Analytics within High-Performance Design,</i> Amanda Stacy	544
<i>Bridging the Gap: Transparency in Building Materials,</i> Suzanne Drake and Michel Dedeo	545
<i>Dynamic Solar Design,</i> Heath May	546
<i>Fundamental Science Building Research,</i> Leo Alvarez, Dan Watch, Mark Joyner and Regal Leftwich	547
<i>Integrating the Sustainability Tracking, Assessment and Rating System (STARS) into the Campus Master Planning Process,</i> Elizabeth Turner	548
<i>Mission Zero Corridor,</i> Elizabeth Ward	549
<i>Salahaddin University in Erbil,</i> Jimmy Smith	550
<i>Sponge: A New Technology for Performative Surfaces,</i> Inanc Eray	551
<i>Tall Wood The Obstacles of Perception,</i> Shawna Hammon	552
<i>The Innovation Incubator: Micro-Grants and A Culture of Innovation,</i> Leigh Christy, Diana Davis, Mark Walsh and Brian Weatherford	553
<i>UCSF School of Medicine [Som] Workplace Research Project,</i> Janice Barnes	554
<i>Using Field Research + Parametric Analysis to Inform Medical Planning & Design,</i> Upali Nanda	555

Research and Education in Academia

<i>Architecture at the Edge of Practice: Developing Alternative Design Pedagogical Hybrid Model,</i> Nkemakonam Okofu	557
<i>Beyond Tutorials: Using Active Learning to Improve Computational Design Instruction,</i> Nicholas Senske	564
<i>Collaborative Solid Wood Construction Case Study,</i> Erin Carraher and Jorg Rugemer	571
<i>Comparative Analysis of Architectural Education Standard across the World,</i> Suchismita Bhattacharjee and Shivashish Bose	579
<i>Emerging Technologies and Disruptive Programming Research in the Design Studio,</i> Greg Stroh	590
<i>Fieldwork in Ritual Reality: A Qualitative Method in Architectural Research and Education,</i> Magi Sarvimaeki	599
<i>Fusion of Teaching and Research: Design Support Tools and Vegetated Walls,</i> Kenneth Black, James Jones, Mario Cortes and Elizabeth Grant	604
<i>Integrating Architectural Research within Interdisciplinary Global Studies,</i> Phoebe Crisman	612
<i>Intern Architects in the Academy: Preparing for Future Practice through Field-Based Research,</i> Caryn Brause	619

<i>Questioning the Role of Online Education in the Architectural Design Studio</i> , Craig Griffen	627
<i>Recalibrated: An Interdisciplinary, Studio-Based Study of Massive Timber for Student Housing</i> , Dustin Albright	631
<i>Research-Based Design as Translational Research between the Academy and Practice</i> , Corey Griffin	639
<i>Scaffolding FRED: Disruptive Discourse and Architectural Progress</i> , Leonard Bachman	647
<i>The Promenade of the Street: A Spatio-Temporal Framework for Design</i> , Mark Blizard and Curtis Fish	655
<i>Toolkit for Passive House Education: Questions, Methods, Tools</i> , Alison Kwok, Walter Grondzik, Katrin Klingenberg and Mike Kernagis	663
<i>Universal Design in Architectural Education: Who is Doing It? How is It Being Done?</i> Megan Basnak, Beth Tauke and Sue Weidemann	670
General	
<i>Cuba, Historic Preservation: Integrated Community and Policy</i> , Emily Dallmeyer	679
<i>Evaluative Place-Making of the Arts and Craft Movement: A Sustainability Framework</i> , Jeanette Burman and Brian Sinclair	687
<i>Representation and Installation: Curating Architectural Exhibitions</i> , Vikkie Chen	696
In Progress	
<i>An Architecturally Optimized Mono-Nitrogen Oxide Reducing Modular Photo-Catalytic Concrete Skin</i> , Meredith Sattler	704
<i>An Integrated Platform for Building Performance Analysis Using Grasshopper</i> , Ajith Rao	705
<i>Collaborative Leadership: A Field Theory for Architectural Practice</i> , Ryan Smith and Erin Carraher	706
<i>Energy Modeling of University of Massachusetts-Amherst Fine Art Center, a Modernist Icon</i> , Carl Fiocchi	707
<i>Implementation of a Pedestrian Link to the Infrastructure of Urban Cities</i> , Michelle Hook and Loran Newman	708
<i>New Perspectives and Future Directions of BIM Workflows: From Digital Tectonic to Digital Fabrication and Assemblage</i> , Awilda Rodriguez Carrion	709
<i>Post-Petroleum Design: Practices and Principles</i> , George Elvin	710
<i>Systems Thinking at the Get Go</i> , Ray Mann	711
<i>Thermostatic Bimetal Integrated Facade as a Micro-Climate Controller</i> , Kyoung-Hee Kim	712
<i>Typological Studies for Passive Design Strategies Based on Coupled Measured and Modelled Data</i> , Ulrike Passe	713
<i>Urban Resilience: Measuring Place Identity in Sustainable Communities</i> , Celen Pasalar, George Hallowel and Aliaa Elabd	714

ARCC 2015 CONFERENCE COMMITTEES

Conference Organizing Committee

Ajla Aksamija, Chair (University of Massachusetts/Perkins+Will)
John Haymaker, Co-Chair (Perkins+Will)
Abbas Aminmansour, Co-Chair (University of Illinois at Urbana-Champaign)

Conference Technical Committee

Rima Al Ajlouni	Texas Tech University
Craig Anz	Southern Illinois University Carbondale
Leonard Bachman	University of Houston
Liliana Beltran	Texas A&M University
Julio Bermudez	Catholic University of America
Terri Boake	University of Waterloo
Mark Clayton	Texas A&M University
Maresh Dass	Ball State University
Howard Davis	University of Oregon
Lynne Dearborne	University of Illinois at Urbana-Champaign
Keith Diaz-Moore	University of Utah
Dr. Ihab Elzeyadi	University of Oregon
Daniel Faoro	Lawrence Technological University
Michael Gibson	Kansas State University
Saul Golden	University of Ulster
Mary Guzowski	University of Minnesota
Bruce Haglund	University of Idaho
Saif Haq	Texas Tech University
Brooke Harrington	Temple University
Azza Kamal	University of Texas at San Antonio
Kyoung-Hee Kim	University of North Carolina at Charlotte
Alison Kwok	University of Oregon
Khaled Mansy	Oklahoma State University
Valerian Miranda	Texas A&M University
Erin Moore	University of Oregon
Brook Muller	University of Oregon
Rashida Ng	Temple University
Joyce Noe	University of Hawaii at Manoa
Edward Orlowski	Lawrence Technological University
Ulrike Passe	Iowa State University
David Perkes	Mississippi State University
Phillip Plowright	Lawrence Technological University
Ute Poerschke	Pennsylvania State University
Ela Poursani	University of Texas at San Antonio
Ash Ragheb	Lawrence Technological University
Hazem Rashed-Ali	University of Texas at San Antonio
Michelle Reinhart	Georgia Institute of Technology
Magi Sarvimaki	University of Hawaii at Manoa
Paola Sassi	Oxford Brookes University
Adil Sharag-Eldin	Kent State University
Mardelle Shepley	Texas A&M University
Madlen Simon	University of Maryland
Brian Sinclair	University of Calgary
Ryan Smith	University of Utah
Edgar Stach	Philadelphia University
Alexandra Staub	Pennsylvania State University
Jeremy Voorhees	Temple University
Nora Wendl	Portland State University
William Willoughby	Kent State University
Kate Wingert-Playdon	Temple University

INTRODUCTION

Research in architectural design and the built environment is diversifying and reaching new directions. Technological changes, such as new materials, design representations, and construction techniques have accelerated the need to advance knowledge across the design disciplines. Today, research is more important than ever and is becoming an integral component in the design practices. In fact, this is the first time that architectural practice and academic institutions are collaborating and organizing a conference dedicated to architectural research. The theme of ARCC 2015 Conference – The FUTURE of Architectural Research – is intended to help define the future directions of architectural research and practice.

The conference explores interdisciplinary approaches that address advanced materials, building technologies, environmental and energy concerns, computational design, automation in construction and design delivery methods. The intent is to bring together researchers, design practitioners, faculty members, policy makers, funders, educators, and students to discuss the latest achievements in architectural research, to bridge the gap between academic and practice-led research efforts, and to set the course for future direction of architectural research. Technological advancements, environmental considerations and concerns, complexity and requirements of today's design practices, as well as challenging economic factors are some of the impending motives for bridging the gap between academic and applied research.

Conference themes include research topics relating to:

- **Advanced Materials and Building Technologies:** materials, their performance and applications in architectural design, experimental studies, building technologies and implementations in current design projects.
- **Environmental, Energy and Building Performance Factors:** environmental and energy aspects in buildings and cities, high-performance buildings.
- **Computational Design:** computational tools and approaches for design, BIM, parametric modeling, simulations and modeling, use of virtual reality for design.
- **Social and Behavioral Research:** building use and operation, post-occupancy evaluations, and occupant satisfaction.
- **Building Types and Design Methods:** specific building types and their design methods.
- **Research in Practice:** new modes of research specifically suited for design practices, appropriate methods, and implementation of results.
- **Research and Education in Academia:** new modes of research in academic settings, integration of educational curricula and research.

The research papers included in this book address the above stated themes and topics, and provide an excellent overview of cutting-edge architectural research and results. For example, several research papers relate to extremely low-energy and net-zero energy buildings, building-scale and community resiliency, new materials and building technologies, and advanced computational design, prototyping, and fabrication methods present some of the emerging issues. Other research papers focus on specific building types (e.g., commercial, residential, healthcare, learning environments), and discuss the intricacies and design methods that must be taken into account during the design process of these specific building typologies. Social and behavioral research papers discuss occupants' psychological and physiological well-being and identify important considerations and factors that influence operational side of the built environment. Papers that focus on research and education in academia present some of the emerging methods for integrating research and pedagogical modes in architectural design, and discuss variety of case studies.

It is our intention to increase discernibility of current architectural research, both practice-led and from the academy, and begin to form collaborative alliances that will result in wider implementation of research results, improved design practices and outcomes, increased funding for architectural research, and significant impacts on the society and built environment.

Ajla Aksamija, PhD, LEED AP BD+C, CDT
John Haymaker, PhD, AIA, LEED AP
Abbas Aminmansour, PhD

**ADVANCED MATERIALS AND
BUILDING TECHNOLOGIES**

Adaptive efficiencies: Responding to change through anticipatory prefabricated design

Charlotte L. Styer¹

¹WSP, Washington, DC

ABSTRACT: Pedagogically, the study of architecture often revolves around the creation of new, program-specific designs. In practice, buildings are newly constructed and occupied based on their intended program use without forethought. As requirements change, buildings go through series of modifications. When modifications are no longer feasible, buildings are often demolished or left vacant. In an effort to combat this one-time-use mentality, *Adaptive Efficiencies* offers an architectural system that adapts to a building's differing physical and programmatic requirements through the use of prefabricated, deconstructable panels, or *Fins*.

The programmatic and physical lifespans of urban buildings are influenced by two major factors. First, the vacancy rate of commercial spaces remains the highest of the sectors within the real estate market each year as the supply continues to outweigh the demand and tenants move elsewhere, leaving owners without prospective replacements (Molony 2012b). Concurrently, residential spaces continue to be in high demand (Molony 2012b). It seems as if one issue could present a solution for the other, yet in many cases, the vacant building is demolished and a new structure is erected in its place.

Rather than demolish, choosing to reuse buildings decreases the environmental impacts and energy use associated with building construction (*The Greenest Building* 2011). Yet the current methodology of adaptive reuse poses only momentary solutions. Eventually, the reused building encounters the same problem with which it started: vacancy, no longer needed for its intended program use. A widely accepted architectural methodology has yet to be developed that anticipates future reuse.

By employing design flexibilities within the context of adaptive reuse and reconstruction, one could essentially design for more than just a building's second use. The proposed *Fin System* is devised with material efficiency and disassembly in mind so that a building may adapt to a new program use each time the demand changes. Taking advantage of standard material dimensions, the *System* includes a series of wall panels in nominal dimensions that reduces the production of material waste during construction. These panels, built with mechanical fasteners for increased ease of disassembly, can be transported from floor to floor by using a standard service elevator, eliminating the need for a crane. Standardized installation of a prefabricated kit of parts allows for design flexibility within a framework that provides a new use for a building, decreases the amount of material waste in demolition and construction, and offers a new program for an outdated space.

The design study demonstrated an application of the prefabricated *Fin System* and its construction methodology through the adaptive reuse of the office space of 1851 South Bell Street in Crystal City, VA. The following illustrates the benefit of adaptive reuse over demolition to satisfy the need for residential space in Crystal City. The achieved outcome of the research and design of the *Fin System* when combined with various passive strategies created a material-, water- and energy-efficient building.

KEYWORDS: Prefabrication, Adaptive Reuse, Deconstruction, Efficient, Fin System

INTRODUCTION

In order to combat waste produced during building demolition, it must be understood how building typologies *live* and what factors influence their lifespan. Many times, building vacancy is a major source of demolition incentives and so vacancy patterns must be identified. Although multiple strategies for building reuse have been practiced over the years, a methodological approach to reuse is not yet entrenched within architectural practice. The following case study seeks to identify a feasible alternative to demolition through the research of flexible and efficient building initiatives, and the study of building lifecycle and vacancy values.

1.0 OFFICE BUILDING VACANCY

Of the sectors within today's real estate market, the office sector continues to report the highest vacancy rate each year; hovering around 17 percent compared to the multifamily residential sector's 4 percent (Molony 2012b). In the late 1980's, office building stock rose in most large American cities as these buildings were being constructed while the demand faded (Kohn and Katz 2002). Today, "[a]s market conditions

evolve, residential values are continuing to improve while offices are becoming more expensive to maintain and have ever shorter life cycles" (Challis 2011, 2).

1.1. Demolition

Not only will reuse help to solve a programmatic imbalance, but it will also reduce the rate of material waste created by demolition within the construction industry. For, "although it represents about 8% of gross domestic product (GDP) in the USA, the construction sector consumes 40% of all extracted materials, produces one-third of the total landfill waste stream, and accounts for 30% of national energy consumption for its operation" (Kibert, Sendzimir, and Guy 2002, 6). There is great potential for adaptive reuse projects to reduce negative social, economic, and environmental impacts at a local and global scale. However, demolition seems to remain the preferred approach within the non-residential sector as shown by the decreasing service life of buildings. In a survey of 105 non-residential buildings, 47 fell within the 26-50 age class (O'Connor 2004, 2). The adaptive reuse of a building can prevent the materials of a demolition project from entering the waste stream (*Estimating 2003: Building-Related: Construction and Demolition Material Amounts* 2009).

2.0 CHALLENGES AND FEASIBILITY OF ADAPTIVE REUSE

Buildings are designed around program-specific requirements that can, in some cases, hinder the viability of an adaptive reuse project. Categorical feasibility factors of adaptive reuse include: structure, exterior finishes, physical design components affecting daylighting, service systems, interior finishes and code regulations.

While structural material degradation may be commonly assumed to directly dictate the service life of buildings, the results of a 2004 North American building service life survey states that in reality, only 3.5% of building demolition was determined by structural failure (O'Connor 2004). Therefore, with a building's structural capacity still functional, the next potential issue to address is the structure's ability to handle the live and dead loads of the new program. The structure of an office building is designed by code to handle greater live loads than residential buildings (*International Code Council 2012*). Therefore when reusing an office building for a residential program, the structural member's ability to accept alterations will not have to be taken into consideration.

In order to maximize the value for the land, most projects are built to maximize rentable floor area. In many cases, this involves constructing the thinnest floor plate in combination with the shortest allowable finished floor to ceiling height in order to ensure the maximum number of floors is incorporated into the design. This eliminates the need to analyze the existing building's structural capacity for additional floors during redesign. Another method of maximizing rentable floor space is to design the structural system to accommodate an open floor plan. In order to preserve the building's structural integrity, existing loadbearing walls or exoskeletons must be incorporated or accounted for within the structural system of the reuse design.

Although designing office buildings with the shortest allowable finished floor to ceiling height maximizes rentable floor space, it creates an undesirable ceiling height for residential spaces. While the finished ceiling height of the typical office building built through the early 2000's is 8'6" or 9'0", "there is a current move, led by many of the high-tech firms, to create more democratic, loft-like, technologically advanced work environments, typically with ceiling heights of 12'0"-14'0", " allowing ample height for either program use (Kohn and Katz 2002, 8, 35). Similar to ceiling height, the amount of daylight that enters a room greatly affects the interior environment.

A daylight room depth should be less than two and a half times the height of the window head to maintain a minimum level of illumination and an even distribution of light (Brown and DeKay 2001, 201).

Strategies for using daylight to light American office buildings were forgotten after World War II, as air conditioning and artificial lighting technology improved. Today, the depth of the floor plate in typical American office buildings seriously impedes natural daylighting abilities as floors often have dimensions of 50 feet from the core to the facade. When reusing an American office building for residential use, it is likely that a courtyard will be carved out of the center of the building in order to both improve daylighting techniques and create a typical floor plate dimension for residential use.

In order to improve an American office building's daylighting performance during its new use, a passive lighting strategy must be incorporated into the design. This will undoubtedly affect the building's mechanical and electrical services designed for the building, which represents another categorical challenge of adaptive reuse projects. Evolving from the private offices of the 1960's, the typical North American office building floor layout is predominantly open today (Kohn and Katz 2002, 5). Adapting the current heating, ventilation and air conditioning systems from either an open floor office or private office layout will require intensive reconfiguration in order to serve each residential unit with individual ductwork. Similarly, the plumbing capacity will need to be adapted from one program to the next, which can be intensive as well. But, in the case of both the HVAC system and the plumbing system, many of the physical fixtures and connections can be reused in the new design. The electrical hardware will be the system likely to produce the most material waste, as the majority of the physical hardware will be replaced by new wireless connections.

As the office hierarchy flattened in the 1980's, the interior finishes and partitions evolved along with the service systems. The typical dropped ceiling found in most office buildings today is designed to conceal ductwork, piping and wiring of these service systems. When removing this ceiling type for security and acoustical privacy reasons in residential applications, the service systems must be reworked within the new design.

Another factor influencing the production of material waste is inseparable from the selection of a material itself. In an effort to reduce first costs, high performance building materials are often traded for a less expensive alternative. But, this exchange could directly affect the material's durability performance, which affects the building's material waste over its lifespan if the less durable material must be replaced. It is possible that the more expensive material is of a higher quality, which would allow it to withstand reuse and therefore offset the initial cost for the material with its long lifespan.

The type connection used in material assemblies greatly affects the material's capacity for reuse. From exterior cladding to interior finishes, each subsequent material choice has a resulting choice of connection. Some materials become less desirable from a reuse standpoint due to the intricacy of their disassembly or their inability to be disassembled. For example, an office building's unitized glass curtain wall is much easier to disassemble and reuse than a concrete mass wall with punch windows.

Restrictions or regulations associated with the International Building Code (IBC) or the National Register of Historic Places (NRHP) can affect the materials incorporated in a building. Fire safety dictates many of the IBC regulations surrounding material types. Concrete construction, found in many Washington DC office buildings, offers multiple benefits as concrete itself is inherently fireproof and can be used to minimize floor-to-floor height where overall building height is limited by code or zoning regulations. While the focus of many IBC regulations center around safety, the intent of the NRHP is to preserve a building's aesthetic qualities that represent local history. Many times, the regulations enforce the preservation of the façade characteristics over the interior design, as it is the most frequently viewed aspect of the design. This restriction could hinder the design of adaptive reuse projects whose strategy for attracting a new tenant type is to use the façade as a way to express its changing program. For this and similar reasons, certain aspects of the codes and other regulatory barriers are relaxed, and tax incentives are proposed in order to promote and increase the speculative profitability of adaptive reuse projects (Kohn and Katz 2002, 149).

While tax incentives or code relaxations attract some interest in adaptive reuse projects, the building industry should not have to rely on incentives as a reward for choosing ecological option. "Buildings currently consume 32% of the world's resources" (*ESD Design Guide* 2007, 04). With the linear product-waste system as the dominant path for the building industry, materials from the "one billion square feet of buildings [that] are demolished and replaced each year" are sent to the landfill rather than saved through reuse (*The Greenest Building* 2011, ix). Not only will this material count toward the carbon footprint of the site, but also the energy embodied in the acts of demolishing the existing building and constructing a new building in its place will count as well. Analysis has found that:

It takes between 10 to 80 years for a new building that is 30 percent more efficient than an average-performing existing building to overcome, through efficient operations, the negative climate change impacts related to the construction process (*The Greenest Building* 2011, viii).

Although an office building may have outlived its designed function, it has not outlived the useful lifespan of some of its materials and its structure. A Life Cycle Assessment will discredit the argument for the demolition of a building for the construction of even an energy efficient building by showing objective numerical proof that the adaptive reuse of a building will consume less energy and exhaust less carbon during the reuse than the new construction.

3.0. CASE STUDY DESIGN STRATEGIES

Once the preferred building typologies for reclamation and reuse have been chosen, and the challenges of adaptive reuse have been identified, the process of locating potential areas of implementation begins. Additionally, design methodologies and objectives are developed.

3.1. Analysis of abandoned office building stock

As a result of the Department of Defense's (DoD) Base Realignment and Closure (BRAC) recommendations in 2005, Arlington, Virginia lost demand for over 4.2 million square feet of leased office space as of September 15, 2011 (*BRAC Transition Center*).

Crystal City is most affected with approximately 3.2 million square feet of [the U. S. General Services Administration's] (GSA) holdings in these buildings considered BRAC-impacted DoD space" (*BRAC Impacted Buildings and Leases in Arlington* 2011, 2).

Losing leases with five agencies of the DoD as a result of BRAC, 1851 South Bell Street of Crystal City is a prime candidate for residential conversion with 309,629 square feet of vacant office space since September 2011 (*BRAC Impacted Buildings and Leases in Arlington* 2011, 8).

3.2. Site analysis

Crystal City has benefitted from its proximity to Washington, DC and major transportation hub Reagan National Airport, becoming one of Arlington's largest concentrations of density and jobs (*Crystal City Sector Plan 2011*). But, with the BRAC recommendations, the city is in great need of redevelopment. The current master plan for Crystal City adopted by the Arlington County board in September of 2010, indicates that a mix of uses will help balance the current single-use dominated areas. Figure 1, below, represents current demolition statistics for Arlington County; indicating not only that retail and commercial demolition is on the rise in recent years, but also that there is a greater amount of commercial and retail demolition compared to residential units. Figure 2, below, denotes residential unit to commercial gross floor area ratios, displaying a deficit of residential units in Arlington County. In an effort to increase the urban density of living as well as the life on the street, a mixed-use program shall be incorporated into the design.

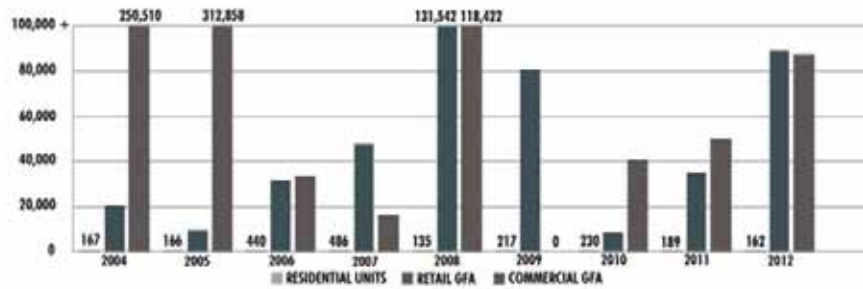

Figure 1: Demolitions in Arlington County, VA. Source: (Graphic: Author 2013, Values: *Arlington, VA Annual Development Highlights 2004-2012*)



Figure 2: Residential unit to commercial gross floor area (GFA) ratio. Source: (Graphic: Author 2013, Values: *Arlington, VA Profile 2013, Building Resilience in Boston 2013, Boston 2013 Housing Report, DC Office Market 2012, Demographic and Housing Profiles 2010*)

3.3. Building candidacy and feasibility

Meeting the initial self-imposed criteria for the feasibility of an office to residential conversion, 1851 South Bell Street possesses many qualities that facilitate the conversion process. While the building was built in 1968, it arguably still has 55 years left to stand, assuming its intended maximum lifespan, like other buildings in the developed world, is 100 years (Kibert, Sendzimir and Guy 2002). As an office building, 1851 South Bell Street was designed with the structural capacity, 50-80 PSF, to house the intended mixed-use program requiring 40 PSF. The building height is 198'0", comprised of twelve floors with the majority of ceiling heights around 9'3". 1851 South Bell Street is a stand-alone office building with a short north façade, preferable for passive heating and cooling techniques. The depth of the floor plate, from the façade to the building core, ranges from 40' to 60', requiring two courtyards to be carved out of the building's interior floor plate to allow for better daylighting and more typical residential floor plate dimensions. The column grid throughout the building is 20'x20' and components of the façade are independent from the building's structure. While the capacity of the current utilities requires an update, additional amenities include eight passenger elevators and one freight elevator. A costly addition to any project, these elevators will amply serve all programs on the twelve floors of the building. Furthermore, 1851 South Bell Street's adjacency to the Crystal City metro station will increase its ability to attract tenants.

3.4. Design and construction efficiency initiatives

While there is no deconstruction system in place within the 1960's design of 1851 South Bell Street, in order to account for the potential future use of the building, construction methods should be high priority. The following expresses estimated percentage of material use during demolition and construction depending on the type of construction method employed. When demolishing a building without employing a reuse strategy, *Option 1*, 100% of the building materials are destroyed and will require 100% of the building materials to be replaced during new construction. When choosing to adaptively reuse a building with traditional construction methods, *Option 2*, we can assume that some of the building materials will be destroyed while some will be reused. So, 50% represents material use during both demolition and construction. The way material

assemblies are constructed and joined, determines its flexibility and adaptability. When adaptively reusing a building and employing prefabricated and adaptive construction methods that anticipate a building's future reuse, we can assume that some degree of efficiency is achieved. Therefore, a figure of 40% represents material efficiency during construction in *Option 3*.

Another efficiency initiative involves digital fabrication, which allows for detailed, computer-accurate customized fabrication. While digital methods and prefabrication should not drive the design, it can be used as a way to mass-produce a fixed set of customized building components with interchangeable universal connections that allow for residential unit variability. The unit matrix developed in the case study includes two, two-bedroom + den units, eight, two-bedroom units, eight, one-bedroom units, and four, studio units per residential floor (Figure 3). Within that matrix, there are multiple floor layouts per unit type. Just as designers have learned to construct building elements with standardized material dimensions, prefabricated components can be used in a similar scalar manner to form a building. Prefabrication already offsets cost differentials, increases productivity in the warehouse and on-site, and even improves contractors' safety. Additional benefits can be achieved if a system is developed that allows these prefabricated elements to be deconstructed, allowing for adaptive reuse to take place.

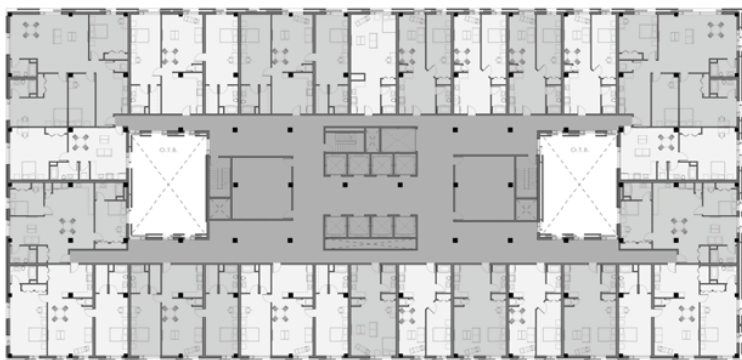

Figure 3: Proposed typical residential floor plan. Source: (Author 2013)

Finally, in order to deliver the project in a time-efficient manner, an adaptive reuse project can take advantage of completing the reuse in stages. Tenants can occupy completed sections of the substantially complete project while construction continues in the remaining portions of the building. If residential construction begins on the top floors of the building, and ground floor retail spaces are constructed, the original office space can remain on the lower floors. As the demand for residential space grows, each sequential floor remaining below can be converted into residential units. Similarly, if the demand for commercial space outweighs that of residential space, the conversion effort can cease.

3.5. The *Fin* system

Using material and energy waste reduction as a driver for design decisions, the *Fin System* developed into a design methodology that uses a series of prefabricated panels connected to create *Fins*. Figure 4 depicts the design methodology flow chart for the *Fin System*. Mechanical, electrical and plumbing systems are included in the prefabricated interior wall panels consisting of metal studs and gypsum wall board, called *Fin Wall Panels* (Figure 5). A number of *Fin Wall Panel* types were developed during the case study to accommodate unit location and variability. These types include, a Bathroom-to-bathroom, a Bathroom-to-kitchen, a Kitchen-only, and a Double-bathroom-to-double-kitchen (Figure 6). Installation is standardized and identical regardless of the apartment unit size, which reduces on-site coordination. Screw connections are used to connect *Fin Wall Panels* together to each other, and to the floor and ceiling, to allow for greater ease of disassembly and reuse (Figure 7). Similarly, non-pressurized mechanical and plumbing pipes are connected with gasketed connections, while pressurized pipes are able to be screwed together with the aid of a length of flexible piping (Figure 8).

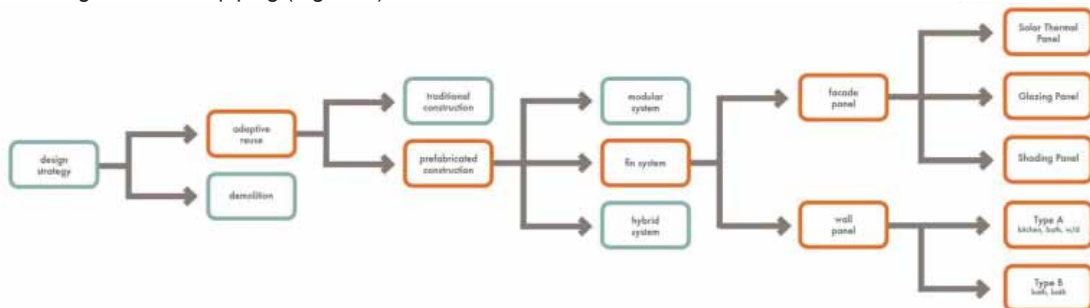

Figure 4: The *Fin System*'s design methodology flow chart. Source: (Author 2013)

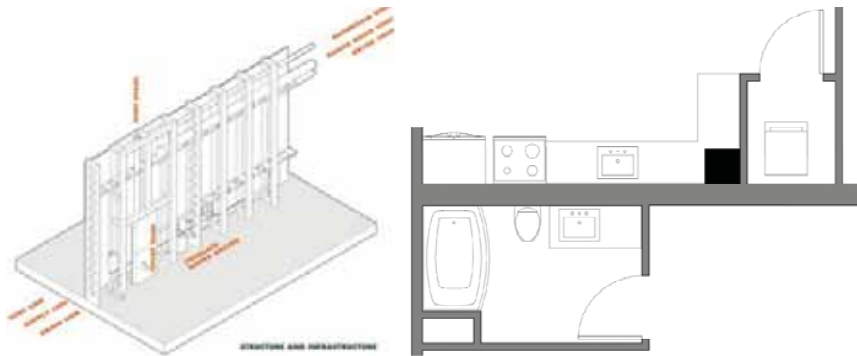

Figure 5: Two, 8-foot Type A *Fin Wall Panels* at a kitchen/bathroom/washer + dryer condition. Source: (Author 2013)

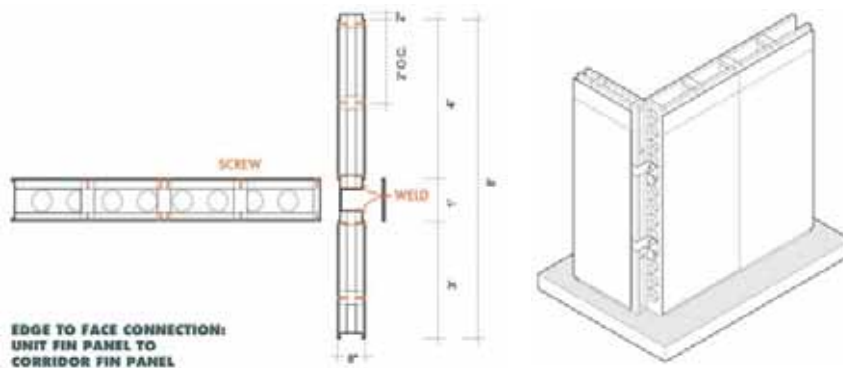

Figure 6: Edge to face *Fin Wall Panel* connection: Unit *Fin Wall Panel* to Corridor *Fin Wall Panel*. Source: (Author 2013)

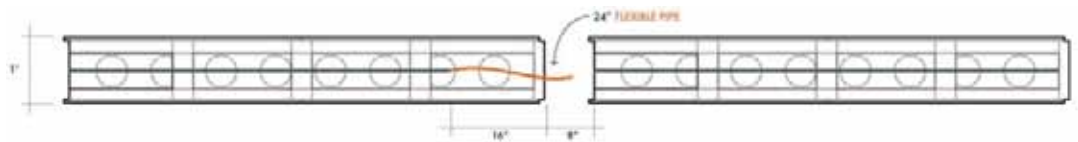

Figure 7: Edge to face *Fin Wall Panel* connection: Unit *Fin Wall Panel* to Corridor *Fin Wall Panel*. Source: (Author 2013)

Additional energy-saving efforts were incorporated into the case study design. In keeping with a paneling methodology, the façade was designed to be a series of solar thermal panels, glazing panels, and louvered shading panels in 2', 4' and 8' sections (Figure 8). Operable louver panels are optimized by orientation to shade the interior and reduce the building's cooling load (Figure 9). Passive evacuated tube (or solar thermal) panels provide supplemental heat for the radiant heating flooring system included in the design (Figure 10). Additionally, the façade panel system is not tied to the interior fin system, allowing for variability in design. Both interior *Fin Wall Panels* and exterior façade panels are designed to stack, which both saves space during transportation from the warehouse, and allows them to fit inside a service elevator, which eliminates the need for a crane during reconstruction.

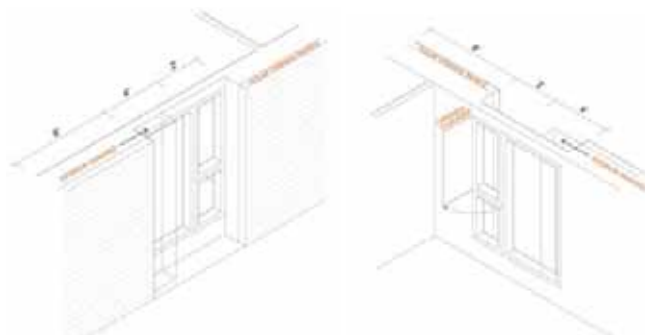

Figure 8: Exterior panelling system axon. Exterior view (left). Interior view (right). Source: (Author 2013)

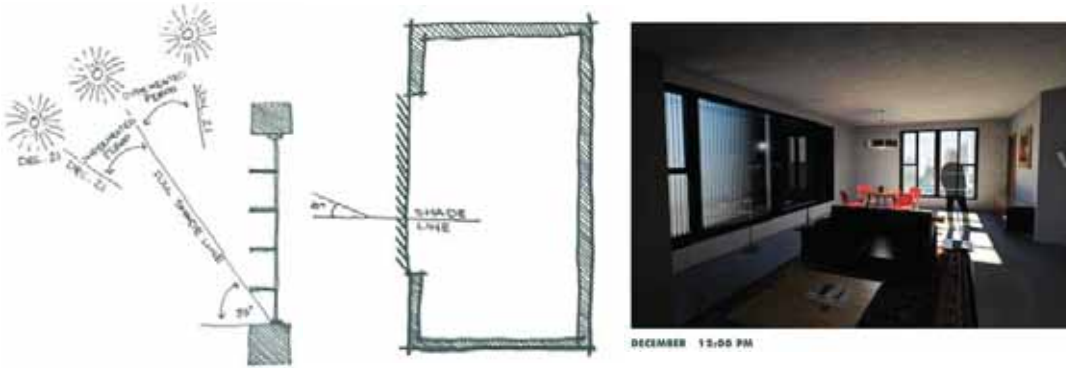

Figure 9: Southern horizontal façade shading orientation diagram (left), Eastern and Western vertical façade shading (right), Rendering of expected daylighting from a SW corner unit in December at 12:00PM. Source: (Author 2013)

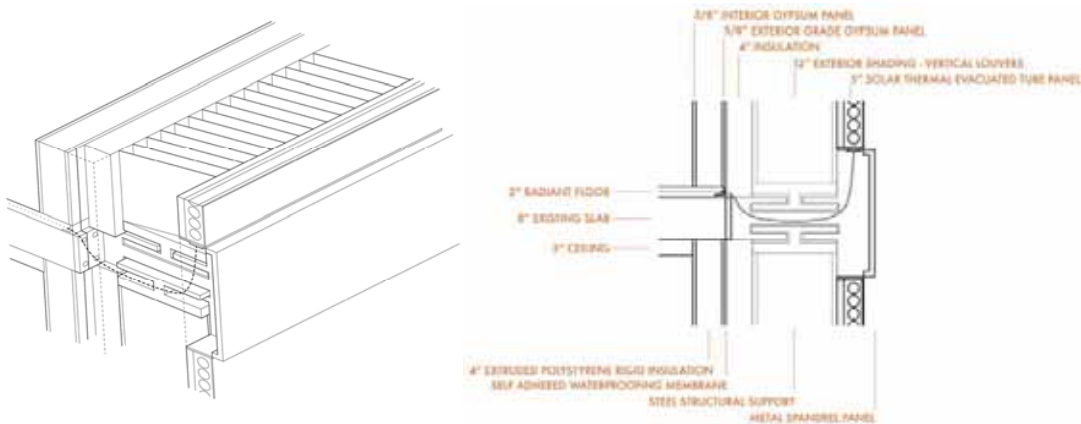

Figure 10: Axon (left) and section (right) of the floor slab to exterior wall assembly detail. Source: (Author 2013)

It is understood that any design decision has an associated consequence. The following decisions are incorporated within the adaptive reuse design: in an effort to save space and material for piping, tankless water heaters installed in the panels replaced the commercial hot water tank. 60% of toilet water supply is supplied by rain water collection, reducing water demand. While additional piping is needed for toilet rain water supply lines, hot water piping lengths are reduced with tank-less water heaters. Replacing existing windows with operable windows and passive shading devices balances the associated burdens of façade reconstruction by reducing the amount of energy needed to cool the building. The associated material and energy burden required to install a radiant flooring system is balanced by the passive evacuated tube façade panels which reduce the energy demand during cold months. Time and material quantities are saved with the installation of prefabricated panels, which lessens the burdens associated with the removal of interior commercial office finishes throughout the building and floor plate for courtyard space. Deconstruction burdens are additionally reduced with disassembly methods incorporated in the *Fin System* design. The decrease in construction costs associated with the elimination of a crane allows for service elevator upgrades, if needed. By using construction cost data from *2010 RSMMeans* guides, the rough estimated cost of demolition efforts for 1851 South Bell Street is \$3 Million (Mewis 2009). For rough estimation purposes, this simply included the demolition figures for interior wall removal, interior floor finish removal, interior concrete slab removal, and exterior concrete and glass removal. The rough estimated cost of reuse with the proposed design is \$7.5 Million (Waier 2009). The rough reuse estimate includes construction figures for interior walls, interior floor finish, exterior glass, exterior metal shading, and exterior wall assemblies. Surely, the numerical and ecological savings combined add value to this proposed methodology for adaptive reuse.

CONCLUSION

With the actual service life of the typical building significantly less than its expected lifespan, the associated amount of waste produced in the construction industry is greater than necessary. Since construction materials comprise three quarters of the nation's raw material use, demolition of buildings without the intent of material reuse creates substantial environmental impacts (*U.S. Material Use Factsheet 2012, 1*). Given that the majority of demolition projects occur due to non-structural motives, it seems that the fashion-driven aspect of architecture has a pronounced negative influence on the building industry's current practice.

Understanding the theories behind humans' settlement patterns and trending cycles of a building's programmatic use, architectural practice may be able to embrace change by incorporating flexible principles into design strategies. By pre-planning, architects can create buildings that adapt as changes occur. Not limited to new construction, these adaptive strategies can be incorporated into the *second-use* of a building to encourage another use in the future. With technological advances facilitating many aspects of architectural practice, including a building's adaptability, it is important to remember the primary functional characteristics of architecture and to achieve that function without excess simply because technology has made it possible. The balance of technology, materiality and functionality within ecological architecture helps create an environmentally conscious product while incorporating cutting-edge efficiency with required performance parameters.

REFERENCES

- ESD Design Guide: Office and Public Buildings. Edition 3.* 2007. Canberra, ACT: Australian Government Department of the Environment and Water Resources.
- Estimating 2003: Building-Related: Construction and Demolition Material Amounts.* 2009 Washington, DC: Environmental Protection Agency.
- The Greenest Building: Quantifying the Environmental Value of Building Reuse.* 2011. Seattle, WA: National Trust for Historic Preservation: Preservation Green Lab.
- BRAC Impacted Buildings and Leases in Arlington: Crystal City.* 2011. Arlington, VA: BRAC Transition Center.
- Crystal City Sector Plan.* Arlington, VA. 2009. Department of Community Planning, Housing & Development, Planning Division.
- U.S. Material Use Factsheet.* 2012. Pub No. CSS05-18. Ann Arbor, MI: Center for Sustainable Systems, University of Michigan.
- Arlington, Virginia Profile.* 2013. Arlington, VA: Planning Research, Analysis and Graphics Section of the Department of Community Planning, Housing and Development.
- "Annual Development Highlights – Projects & Planning". *Arlington County Government*. 2004-2012. <http://projects.arlingtonva.us/data-research/development/annual-development-highlights/>.
- Balboni, Barbara. 2009. *Assemblies and Cost Data 2010*. Kingston, MA: RS Means Co.
- BRAC Transition Center. "Crystal City." *BRAC Arlington VA.* 2013. <http://www.bracarlingtonva.us/default/index.cfm/audiences/crystal-city/>.
- Brown, G. Z. and Mark DeKay. 2001. *Sun, Wind & Light: Architectural Design Strategies*. New York: Wiley.
- Challis, Adam. 2011. "Office to Residential Conversion: Where the Action is?". *ULI Europe InfoBurst*. November 2011.
- DC Office of Planning State Data Center. *District of Columbia Census 2010 Demographic and Housing Profiles by Ward.* 2010. U.S. Census Bureau.
- International Code Council. 2011. *International Code Council Performance Code for Buildings and Facilities 2012 ICCPC*. Country Club Hills, Ill: International Code Council, Inc.
- Kibert, Charles J., Jan Sendzimir, and G. Bradley Guy. 2002. *Construction Ecology: Nature as the Basis for Green Buildings*. New York: Spon Press.
- Kohn, A. Eugene and Paul Katz. 2002. *Building Type Basics for Office Buildings*. New York: John Wiley & Sons.
- Linnean Solutions, 2013. The Built Environment Coalition, and The Resilient Design Institute. *Building Resilience in Boston: "Best Practices" for Climate Change Adaptation and Resilience for Existing Buildings*. Boston Green Ribbon Commission Climate Preparedness Working Group.
- Mewis, Bob. 2009. *Repair and Remodeling Cost Data 2010*. Kingston, MA: RS Means Co.
- Molony, Walter. 2012a. "Commercial Real Estate Vacancy Rates Improving, Rents Firming". *Realtor*. National Association of Realtors: Chicago, IL. <http://www.realtor.org/news-releases/2012/02/commercial-real-estate-vacancy-rates-improving-rents-firming>.
- Molony, Walter. 2012b. "Commercial Real Estate Vacancies Slowly Declining, Rents Rising". *Realtor*. National Association of Realtors: Chicago, IL. <http://www.realtor.org/news-releases/2012/11/commercial-real-estate-vacancies-slowly-declining-rents-rising>.
- O'Connor, Jennifer. 2004. *Survey on Actual Service Lives for North American Buildings*. Vancouver, B.C., Canada: Forintek Canada Corp.
- Perez, Yolanda, John Avault and Jim Vrabel. 2004. *Residential Land Use In Boston 592*. Boston Redevelopment Authority.
- Spencer, Eugene R. 2009. *Site Work and Landscape Cost Data 2010*. Kingston, MA: RS Means Co.
- Waier, Phillip R. 2009. *Building Construction Cost Data 2010*. Kingston, MA: RS Means Co.

Apples to oranges: Comparing building materials data

Liane Hancock¹

¹Louisiana Tech University, Ruston, LA

ABSTRACT: The building materials sector is composed of a highly distributed network of companies. Ranging in size from boutique companies such as Kirei USA, to architectural divisions within large multi-national conglomerates like Dupont, each manufacturer approaches their communications on building materials' performance and sustainability data differently. The information and terminology are often tailored specifically to the sector and are difficult to decode. As the sector embraces greater transparency, new quantities of data have emerged. However, because no platform attempts to present all performance and sustainability metrics, it is difficult to compare materials side by side. Our paper describes an inclusive model of criteria, with its varied terminology: look and feel; performance criteria; sustainability metrics; ecolabels and LEED points; plus access to MSDS, health product declarations, and environmental product declarations. It also discusses an initial input of seventy materials distributes data across the model.

Initial selection of performance criteria derives from building codes, ASTM standards and government directives, with nomenclature deriving from an analysis of building materials specifications. Sustainability criteria originate in the analysis of eight reputable materials sustainability standards selected across standard types and industries. Because our model is designed to dynamically mirror changes in the sector, initial data entry results in additional criteria for the model.

With over two hundred criteria, our model produces information at the scale of big data. Analysis of the input data is most surprising in the area of sustainability: large voids in information are revealed. Additionally, the visualization of the data indicates significant patterns in the report of information, and where harmonization currently occurs.

KEYWORDS: Materials, Big Data, Sustainability, Performance

INTRODUCTION

Globally, as the world's population increasingly moves to urban environments, it is well documented that there will be a tremendous increase in construction.¹ To accommodate this construction both in the US and globally, the building industry relies on a materials sector with a highly distributed network of companies that are loosely affiliated. Unlike the airline industry, the building materials sector cannot depend upon big manufacturers like Boeing, Lockheed or Airbus for standardization in data. Ranging in size from boutique companies such as Kirei USA, to architectural divisions within large multi-national conglomerates like Dupont, each manufacturer approaches their communications differently, and comparison between products is nearly impossible.

This paper investigates the specific issues that make the comparisons of sustainability and performance metrics problematic. It discusses the isolation of industries with regards to reporting of data, and range of dialects in terminology that result. It then presents the wide landscape of sustainability and performance metrics that exist across the sector, and the distribution of data that is reported by manufacturers on these metrics. As the sector embraces greater transparency, our research uses a base set of seventy building materials to show the quantities of data that have been published by manufacturers. Our analysis reveals a landscape of big data fraught with substantial voids in information. The paper concludes with an analysis of which industries embrace publication of data, and harmonization.

1.0 DATA DIALECTS

The data that manufacturers present on their materials is often tailored specifically to their specific industry, such as the carpet or glass industry. The terminology and distribution of information isolates these industries from users and from each other. Each industry speaks its own dialect, and there is no infrastructure that acts as translator. For example, terminology describing performance characteristics is highly specific, but the words themselves are barely distinguishable. Color fast, fade resistant, lightfastness, and UV resistance relate to degradation of materials by the sun. The carpet industry and the upholstery industry use distinct terminology, because of the specific effects upon their products. But, this vocabulary is nearly homogenous to anyone else. The healthcare industry differentiates between antibacterial, bacteria resistant and

bacteriostatic; necessary differentiation, but again confusing to the uninitiated. For fire resistance, materials bear the label Class 1, 2 or Class A, B, C depending on level of flame spread. The numeric system applies to materials like gypsum board, plywood and carpet while the alphabetical system applies to roofs, ceiling tiles, some countertops, and wall-covering.

Sustainability accentuates these dialects. Environmental impacts can be divided into six categories: ⁱⁱ resource use, energy use, human health and toxicity, emissions, water use, and social accountability. These impacts occur across the stages of processing, manufacturing, and using materials. Different products use widely different resources. Some require large amounts of raw materials, others are energy intensive, and still others significantly impact water resources. Each environmental impact can be subdivided into subcategories. The terminology within these subcategories is particular; but it is also similar enough that it becomes difficult to distinguish.

To create value for a manufacturer's environmentally sustainable efforts, many companies seek certification for their products in order to display an ecolabel seal on marketing materials and product packaging. Evaluating extraction, processing, manufacture, and disposal of building materials, there are dozens of certifications: Cradle 2 Cradle, GreenGuard, Nordic Swan, EU Ecolabel, and FSC are just a few. However, the number and variety of standards creates confusion. In addition, the certifications have non-descriptive and indistinguishable names, insignia and seals, and often those names and graphics are only tangentially related to what is being certified. With the exception of Energy Star and FSC, these certifications bear little name recognition except within their specific sector. ⁱⁱⁱ The certifications often are also opaque. Manufacturers choose which criteria they wish to fulfill, and then both certifiers and manufacturers do not reveal this information publicly.

Unlike certifications that focus only on a building product, BREEAM and USGBC LEED are different: they certify an entire building. For example, LEED criteria emphasize how materials, products and systems behave in a building once they are installed, with a small number of criteria focusing upon the sourcing of building materials. Across the 110 criteria Material & Resources environmental product declaration, sourcing

PERFORMANCE ATTRIBUTES





PERFORMANCE		
	 <p>Moisture</p>	<p>Absorbent Porous Wicking Treated/Sealed Water Resistant</p>
		<p>Waterproof Impervious Moisture Resistant</p>
	 <p>Acoustic</p>	<p>Sound Reflecting Sound Diffusing Sound Absorbing Sound Deadening</p>
	 <p>Fire</p>	<p>Fireproof Fire Retardant Fire Resistant Flame Retardant Flame Resistant Heat Resistant</p>
		<p>Smoke Resistant Self Extinguishing Fire Suppression Class A, Class B, Class C Class 1, Class 2</p>
	 <p>UV (SUN)</p>	<p>UV Resistant Fade Resistant Color Fast Lightfastness</p>
	 <p>Durability & Resistance</p>	<p>SURFACE RESISTANCE Bulletproof Puncture Resistant Impact Resistant Scratch Resistant Sag Resistant Wear Resistant Stain Resistant Soil Resistant</p>
		<p>CHEMICAL Anti-Corrosive Chemical Resistant Bleach Resistant Acid Resistant</p>
		<p>BACTERIA Antibacterial Bacteria Resistant Bacteriostatic Bactericidal</p>
	<p>ANTISTATIC Anti-Static Static Control</p>	<p>Non-Porous Mildew/Mold Resistant Antimicrobial Anti-Allergenic</p>
	<p>FRICTION Skid Resistant Skid Resistant Slip Resistant</p>	

Figure 1: Performance criteria included in the model. Source: (Author 2014)

SUSTAINABILITY ATTRIBUTES











SUSTAINABILITY ATTRIBUTES	 <p>Recycled Content: Post Industrial, Post Consumer Reclaimed/Reused Content Biologically Based Content Rapidly Renewable Content Wood Sourcing Verification Biodegradability/Compostibility</p>	<p>Designed for Disassembly Dematerialization Recovery Program: Material, Product, Waste LCI Reductions Raw Material Extraction Impact Study Publicly Disclosed Material Inventory Abundant Chain of Custody Verified</p>
	 <p>Energy Use: Reduction, Limits Embodied Energy Renewable Energy Offsets Energy Recovery</p>	<p>LCI Reductions: Energy Efficiency Publicly Disclosed Strategy Energy Use Publicly Disclosed Energy Audit R Value Reduction/increase Thermal Transmission</p>
	 <p>Public Disclosure of Toxins, Reduction of Toxins, Ban of Toxins: Through Red Lists, Chemical Families, Specific Chemicals</p>	<p>LCI Reductions Publicly Disclosed Material Formula Third Party Toxicology Assessment Fire: Reduction, Limits, No Toxic Fumes Cleaning Program: Non Toxic Chemicals</p>
	 <p>Public Disclosure of Emissions, Reduction of Emissions, Ban of Emissions: Through Red Lists, Chemical Families, Specific Chemicals</p>	<p>Embodied Carbon LCI Reductions: Climate Change Emissions Air Filtration</p>
	 <p>Water Consumption: Public Disclosure, Reductions, Limits Net-Zero Water Waterfootprint Water Recycling</p>	<p>Waste Water Quality Body of Water Protection LCI Reduction: Eutrophication, Water Use Reduction Erosion Control Self Cleaning</p>
	 <p>ISO Compliant Environmental Management System ISO Compliant Quality Management System Employee Training for Ethics</p>	<p>US Labor Practices Adopted at All Global Facilities Supplier Assessment and Verifications Public Statement of on Non-Discrimination Labor Force Metrics Reported</p>
CERTIFICATIONS		
LEED	 <p>Sustainable Sites Water Efficiency Materials and Resources Indoor Air Quality Innovation in Design Regional Priority</p>	
DOCUMENTATION	 	<p>LCA MSDS</p> <p>Life Cycle Assessment</p>

Figure 2: Sustainability criteria included in the model. Source: (Author 2014)

of raw materials, and material ingredients, and Indoor Environmental Quality Credit low emitting materials are the main credits that pertain to materials (USGBC, 2014). This is like trying to define manufacturers' efforts on sustainability through a language of nine words.

2.0 RESEARCH METHOD

In order to fully describe the building materials it was necessary to design a model for the data. We charged ourselves with the task of developing a holistic, consistent, and relevant way to present the full picture of building materials in a single platform single page format: look and feel; performance criteria; sustainability metrics; ecolabels and LEED points; and access to MSDS, health product declarations, and environmental product declarations. Performance criteria originate from building codes, ASTM standards and government directives, with nomenclature presenting itself through an analysis of building materials specifications and data.

To build the sustainability portion of the database, we aggregated the sustainability criteria from eight reputable materials sustainability certifications: Cradle 2 Cradle, SMaRT, EU Flower, Good Environmental Choice Australia, Nordic Swan, NSF/ANSI 140, BIFMA, NSF/ANSI 336. Each criterion for the certification was listed, and grouped into sub categories within the six environmental impacts categories: resource use, energy use, human health and toxicity, emissions, water use, and social accountability.^{iv} These certifications were selected to most broadly represent the material sustainability certification landscape, and their criteria focus upon resource extraction, manufacturing, and end of life phases. LEED criteria, and criteria that emphasized sustainability during the performance, such as the energy efficiency measured through R value, were also added. Then as the model was populated, the initial input of materials data provided additional criteria.

To design the database, we developed a traditional, static, hierarchical taxonomy for characteristics such as material makeup, texture, and finish based upon knowledge of the sector. When describing performance and sustainability criteria, however, a heuristic method became necessary. While a selection of specifications and certifications provided the bulk of the criteria, no one source of information provided all the possible terms. Plus, additional terms became apparent as individual materials were entered. If the database was implemented as a static tool, the criteria would be limited to what existed at the time that the database was initially modeled. A dynamic environment was needed, where criteria could be added in real time, and as those criteria were added they could be made available to all the materials that had been entered previously.

We recognized that all performance and sustainable criteria could be described with the same four characteristics: a unique name for each criterion, which is common across all building material entries; whether the criterion was measureable; if it was measureable, one or more numeric (data) entries; and a list of unit(s) associated with the criterion, so that the appropriate unit of measure could be selected by the user. Depending upon the type of criterion, the database presents different subsets from the master unit list. For example, for the criterion Post-Consumer Recycled Content, a % as unit is appropriate. For the criterion Dematerialization a % (of decrease in material) and numeric entry of start date to end date, in years, is appropriate. For the criterion Embodied Energy the unit is energy unit/product unit, so for example btu/ft².^v Exceptions from this typical structure are toxicity and emissions. In these cases each named criteria required selection from a drop down menu of: emissions terms, redlist(s), chemical family (or families), or individual chemical(s), with each selection allowing further numeric entry and choice of corresponding unit.

The initial dataset of seventy building materials represented both interior and exterior applications. Building materials were grouped by application, such as exterior cladding or glazing. We felt it was important to represent a range of manufacturers within a given application, thereby presenting groupings of data that are more easily compared across the broader sector. Only one material per manufacturer is represented and only the data represented on the manufactures website in conjunction with environmental product declarations, life cycle analysis and health product declarations is entered into the model. No assumptions about data have been made. For instance, even though silica is locally sourced by the glass industry, regional priority is not mentioned on glass manufacturers' websites and therefore is not included in the data. In an effort to represent the range of data that manufacturers are publishing on sustainability, our selection included a preponderance of manufacturers that are considered leaders in sustainability and approximately 17% of the materials entered carry a health product declaration, environmental product declaration and/or life cycle assessment.

3.0 BIG DATA AND THE GREAT VOID

With over fifty performance criteria, and more than one hundred and fifty criteria focusing upon sustainability, our database represents the breadth of performance and sustainability criteria that exist in the sector today (see Fig. 1 & 2 for reference). With so many possibilities, the model produces information at the scale of big data. An initial input of seventy building materials yields an analysis that is most surprising in the area of sustainability: visualization of the data reveals significant voids in information. For example, even though we include a range of manufacturers who are considered leaders in sustainability in the initial dataset, no individual material presents data on more than 22 sustainability criteria, equivalent to 14% of possible criteria.^{vi} The forty-four interior materials from the initial dataset yield a total of 334 data entries and the twenty-six exterior materials yield a total of 156 data entries. We calculated the percentages: for interior materials, sustainability data is published for 4.8% of the total possible criteria; and for the exterior materials that percentage is 3.8%.^{vii} (See Fig. 4 & 5)

We believe there are several contributing factors. While manufacturers are releasing more data in efforts of transparency, there is still great hesitancy to reveal information on material makeup and processing. Under the shield of trade secrets, companies shroud toxic materials and processes that they are uninterested in revealing, leaving a large void within the human health and toxicity impact category. Looking across the data, it also seems that manufacturers are predominantly focused upon only what data their direct

competitors reveal, and lack a broader understanding of the range of metrics that can be studied. Particularly surprising is the glass industry: the production of glass is an energy intensive process, and so it is understandable that these companies do not publish information on their energy usage. However they are also silent on water use, social accountability, energy recovery, and regional priority for their resources.

The largest disclosure of data is in the resource use impact category for interior finishes. This is consistent with the fact that the public is most likely to be involved in material selection. They have the greatest awareness of this impact category; and are therefore most likely to ask for a manufacturer's metrics in this area and respond to marketing on the subject. This impact category is also one of two places that LEED awards points for the selection of building materials. (Reference Fig. 3)

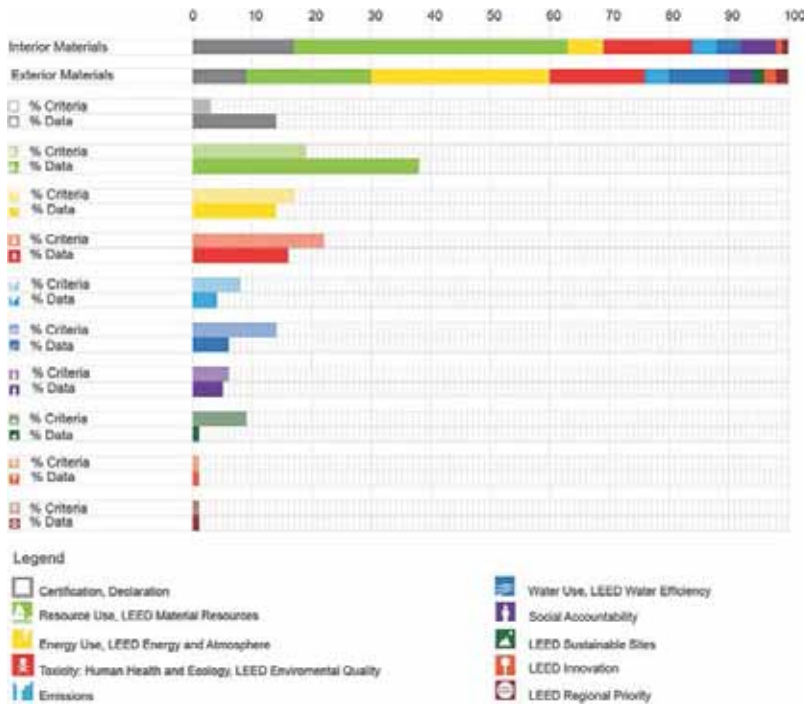

Figure 3: Distribution of both criteria and initial input data in percentages. Source: (Author 2014)

3.1. Environmental impacts

Most companies with significant biologically based makeup focus their sustainability efforts in the resource use impact category; conversely, materials with significant petroleum-based content downplay that content by presenting a broader range of data across impact categories. This seems true of the plastics industry and may partially explain the breadth of data that the carpet industry publishes. With regard to exterior materials, the greatest focus is upon sustainability through energy performance. Human Health and Toxicity presents some of the oldest and most harmonized metrics, many of which were established through legislation. Taking Human Health and Toxicity together with LEED Environmental Quality, 22% of the criteria are dedicated to this impact category – the greatest percentage among impact categories. It is interesting to note Certifications, and Resource Use each hold a smaller percentage of criteria, but our analysis shows a larger percent of data falling into those criteria. This is testament to their popularity. Water is one of the most recently implemented impact categories, and has relatively few criteria. Across the initial dataset, the ceramic tile industry and the carpet industry have the most harmonized response in reporting on water data. Social Accountability holds a relatively small percentage of criteria and data with most of the criteria rooted in applying US legislation abroad. (Reference Fig. 3)

3.2. Uptake and harmonization

Analysis of the initial dataset indicates significant patterns where harmonization occurs. For example, the carpet industry shows consistency, reporting data across nearly all impact categories. In contrast, wallcovering and upholstery companies deliver almost no information on sustainability initiatives. With regard to size, it seems that large manufacturers, such as Weyerhaeuser and Dupont, have the financial resources to test for a broad range of criteria, producing data across all sustainable impact categories. On the opposite end of the scale, a number of small companies have embraced collecting data on sustainability as a way to differentiate themselves from larger firms. A good example is Forbo and their product Marmoleum. In a few cases the data reveals direct competition between firms that have nearly

indistinguishable products. A good comparison is between Metlspan and Kingspan, who have elected to both publish an Environmental Product Declaration, revealing data on nearly the same criteria. (Reference Fig. 4 & 5)

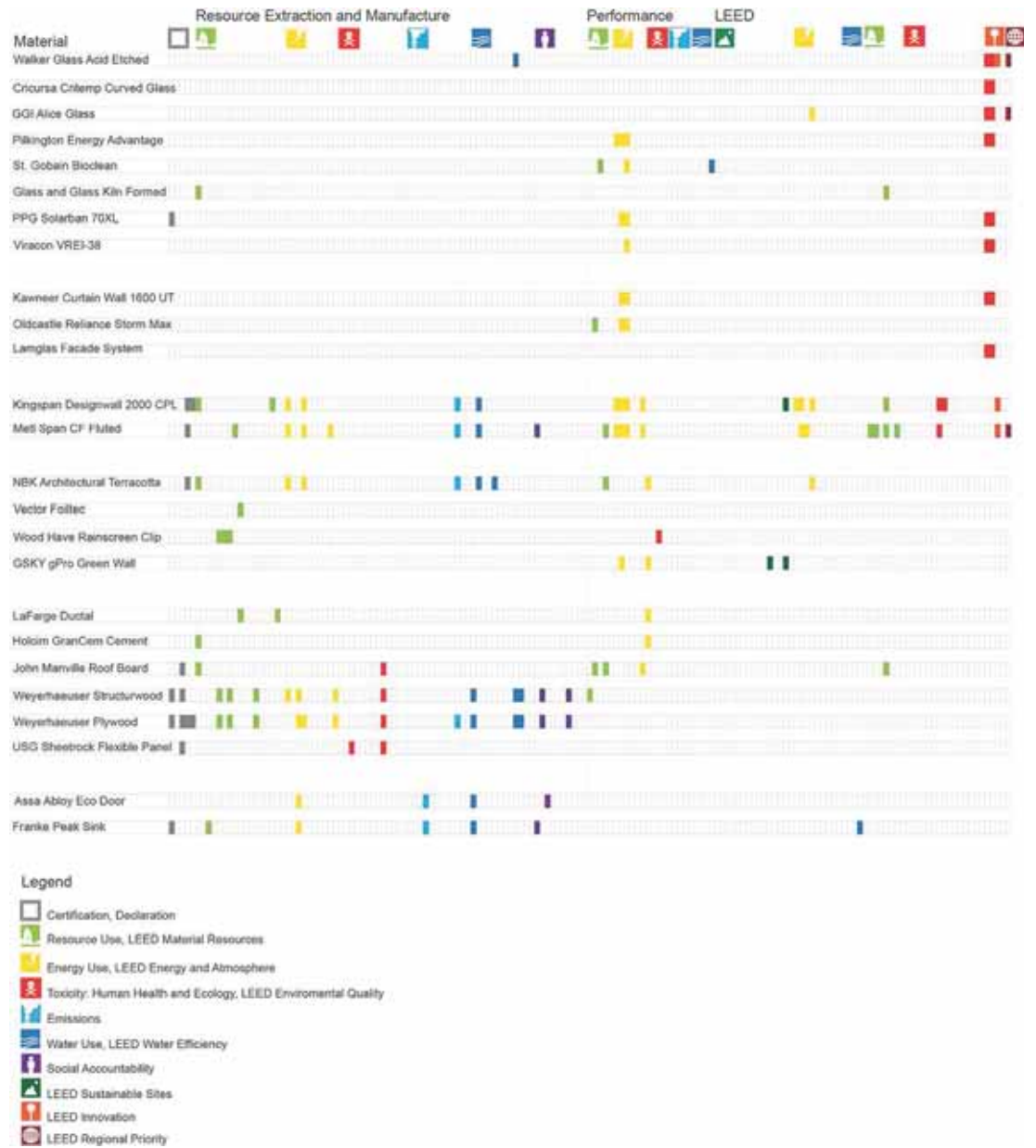

Figure 4: Visualization of the data for seventy initial materials shows every sustainability criterion for each material and whether the criterion's value is null (blank) or whether data has been entered (colored block). Colored blocks are organized as: a certification/ecolabel/declaration; environmental impact category; and/or LEED category. This figure represents analysis of data for twenty six exterior materials. Source: (Author 2014)

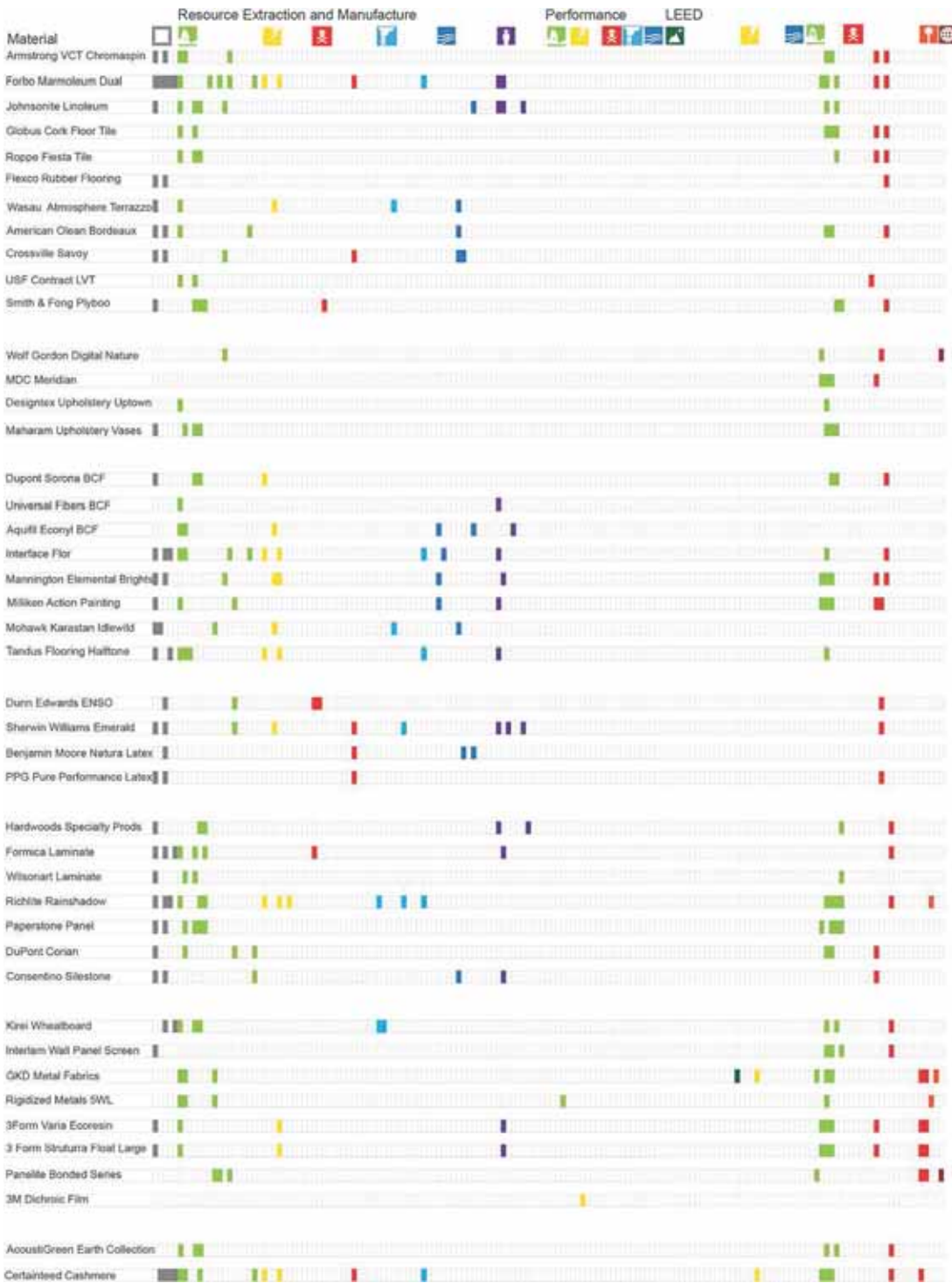

Figure 5: Visualization of input data for forty four interior materials. Source: (Author 2014)

CONCLUSION

The variation in terminology and the lack of comprehensive data across environmental impact categories seems to derive from the fact that individual industries have tailored their efforts on sustainability. This facilitates comparison of products within the same category; however, because the individual industries within the building materials sector are isolated, parallel industries seem to have little knowledge of each other's activities. It remains completely foreign that one source could simultaneously provide data on

performance characteristics and sustainable impacts for a perforated metal panel system, a wood louver system, and a terracotta rainscreen.

Existing materials databases are a repository for subsets of the broad range of data available. MaterialConnexion, material.nl, and the UT Austin materials lab provide data on material look, feel and performance, but are largely silent on sustainability. EcoScorecard offers a database of over 30,000 materials, but limits sustainability information to LEED points. BEES and Pharos go into great detail evaluating the toxicity of materials. None of these search engines produces a complete data picture, or allows for meaningful comparison across materials and industries. We have attempted the first step in that process by creating an environment where data across the sector, across lifecycle, can be compared. Instead of simplifying information, we have created a rich and dynamic network of data that provides a picture of where the sector stands within the ever changing data landscape of performance and sustainability. With over two hundred criteria, our model produces information at the scale of big data. The visualization of the information shows the tremendous breadth in distribution of data, while at the same time revealing substantial absences in data. Additionally, the visualization of the data indicates significant patterns in the report of information, and where harmonization currently occurs across the sector and through individual environmental impact categories.

REFERENCES

USGBC, "LEED for New Construction and Major Renovations (v4)," <http://www.usgbc.org/credits/new-construction/v4> Accessed through download scorecard.

ENDNOTES

- ⁱ Joel Cohen, professor of populations at Rockefeller University, states in the Academy of Arts and Sciences Bulletin "From now to 2030, the world will need to accommodate another million urban people in poor and middle-income countries every five days." Cohen, Joel, "Sustainable Cities," *Academy of Arts and Sciences Bulletin* (Summer 2008): p 10.
- ⁱⁱ See Research Methods Section for method of categorization.
- ⁱⁱⁱ Partially this has to do with market saturation. Most of the individual sectors are small, and certifying a material is expensive. As of 2011, when our initial analysis was completed, SMaRT had 14 certified materials; NSF 140 had 232 materials; and Cradle2Cradle had a total of 348 certifications. As of 2014 SMaRT has 16 certified materials; NSF 140 had dropped to 61 materials; and while Cradle2Cradle lists over 2000 certified materials, there are 113 certified building supplies and materials, and 119 interior design materials and furniture, making a total of 232 materials related to the building industry.
- ^{iv} Data based on a study completed at Washington University in St. Louis, in 2011. Eight material sustainability standards were analyzed, looking at the criteria required to achieve certification. The author was a member of the research team. Principal Investigator: Charles McManis Washington University in St. Louis, Project Director: Hannah Rae Roth, Washington University in St. Louis. Other Participants included: Dr. Charles Ebinger, Senior Fellow and Director, Brookings Institution, George Contreras Associate Professor, American University, and a team of graduate and undergraduate research assistants. This research was funded by the Brookings Institution.
- ^v In the case of this example units include: energy unit/linear dimension, energy unit/area, and energy unit/volume such as btu/linear foot, btu/ft², btu/ga; and both English and Metric units. By providing an array of units tailored to the specific criterion, data entry is greatly simplified. In addition, a user may select a specific unit type, and the database can automatically recalculate and display within that system (so English to Metric and Metric to English). This facilitates comparison between materials.
- ^{vi} The material is Kingspan Designwall 2000 CPL. There were 159 possible criteria. $22/159=13.8\%$
- ^{vii} The current dataset includes 44 interior materials. Each material has a total possible number of 159 sustainability criteria. Data is published on 334 sustainability criteria. The calculation is $334 \text{ criteria fulfilled}/(44 \text{ interior materials} * 159 \text{ criteria per material}) = 4.8\%$. The current dataset also includes 26 exterior materials. With 159 possible criteria for each material, we found data published on 156 total criteria. The calculation is $156 \text{ criteria fulfilled}/(26 \text{ exterior materials} * 159 \text{ criteria per materials}) = 3.8\%$.

Assessment of annual energy enhancement for tall building integrated with wind turbines (BIWT)

Farid Abdolhossein Pour¹, Matthew Herman¹, Robert Krawczyk¹

¹Illinois Institute of Technology, Chicago, IL

ABSTRACT: An emerging way to promote sustainability in the built environment is through the incorporation of wind power within buildings resulting in minimum transmission / distribution losses. Yet, the effectiveness of the proposed solutions are highly dependent on early integration of wind power systems with the architectural design process. Existing methods for aerodynamic evaluation of building forms are often not suitable for early design stage due to time and cost restrictions. As a result, the indicated methods often use over simplified conditions that omit the effect of local climate, surrounding terrain and building orientation. This paper, thus, intends to evaluate the effect of mentioned parameters on the annual energy output of a BIWT.

KEYWORDS: Building Integrate with Wind Turbine (BIWT), Wind Turbine, Onsite Energy Production

INTRODUCTION

This paper considers wind power as an important potential renewable energy source in tall buildings due to the possibility of accessing greater wind velocities at higher altitudes. In addition, air-flow patterns around buildings are considerably influenced by tall buildings' geometrical characteristics. Hypothetically, proper modification of building form can turn this unstructured phenomenon into a wind energy enhancement feature through the concentrator effect thus boosting the power production potential of tall buildings with an integrated wind turbine (BIWT). These aerodynamic modifications are typically evaluated via Computational Fluid Dynamic (CFD) or wind tunnel methods. These methods are often too expensive and time-consuming to analyze all annual fluctuations of local wind regimes (velocity, direction, and density) and thus can be inappropriate for use in early design stages when architectural concepts quickly evolve. Consequently, BIWT are often studied under simplified conditions (steady state analysis, single velocity, and angle) and under predicts the BIWT power coefficient and does not fully calculate the annual energy output. By disregarding the wide variety of other criteria influencing "annual energy output". These criteria include fluctuations of local wind regimes, adjacent terrain and building orientation (see Fig. 1).

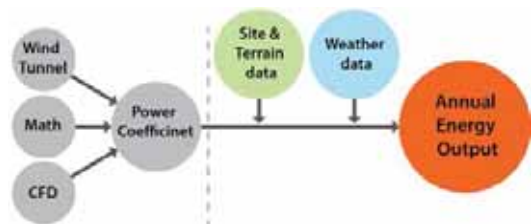

Figure 1: The Data Needed for Estimation of Annual Energy Output, from simplified Power Coefficient Calculations.

This paper intends to evaluate the suitability of BIWT power coefficient as a measure to inform the architectural integration of wind turbine into tall buildings design. The objective is to know whether a higher BIWT power coefficients always guarantee a greater annual energy output regardless of BIWT location and site. Thus, this paper intends to assess the sensitivity of "Local Weather", "Building Direction" and "Surrounding Terrain" on the BIWT annual energy output. The study outlines three BIWT case studies (sections 2.1, 2.2, and 2.3) and obtain the power coefficient profile using the provided math. Calculating the power coefficient profile for three BIWT case studies, the study carry on by approximation of Annual energy output for each case study at four different locations. The comparison of the annual energy productions tells how much local weather patterns, building direction, site terrain and the BIWT typology influence the annual energy output for a location.

1.0 HOURLY ANALYSIS

Based on the issues described in the introduction a research was proposed to streamline the study of BIWT, early in the architectural design process. To develop an appropriate methodology a detailed evaluation of precedent studies and methods were conducted. Many significant BIWT precedent researches reviewed in including the studies by Mertens (2006), Babsail (2011), and Campbell and Stankovic (2000). These evaluations led to a gap identification in BIWT filed of knowledge. The calculation procedures are presented below borrowed from precedent literature to describe a suitable methodology for predicting the

impact and potential benefits of BIWT for various tall building configurations. This work is part of ongoing research at the Illinois Institute of Technology, College of Architecture Ph.D. program.

1.1. Wind Turbine Power Calculation

According to mass conservation law, as long as density (ρ) and v are constant across an imaginary area of A , the total wind power content reads $P_{air} = \frac{1}{2} \rho \cdot v^3 \cdot A$ (Sathyajith, 2006; Stankovic, Campbell, and Harries, 2009). There is always some power losses associated with turbines. So, Per Equation [1], turbine power coefficient (C_p) is the fraction of extracted mechanical power out of total wind power content (Sathyajith, 2006).

$$P_t = \frac{1}{2} C_p \cdot \rho \cdot v^3 \cdot A \quad [1]$$

1.2. Terrain Roughness Length

The ground roughness depends on the local obstacles such as water, soil, trees, and urban areas (Sathyajith, 2006) and influences the wind velocity profile over the terrain. It is described by the term "roughness length (z_0)", which is provided for a set of selected surface types in Table 1 (Manwell, McGowan, and Rogers, 2002).

Table 1: Surface Roughness Length (approximate) by Terrain Type. Source: (Manwell et al., 2002)

Terrain Description	Roughness Length, z_0 (m)
Snow surface	0.003
Fallow field / weather station standard surface type	0.03
Few trees	0.1
Forest and woodlands	0.5
Suburbs	1.5
Centre of cities with tall buildings	3.0

1.3. Historical Weather Data,

Historical weather data is often combined to create a typical meteorological representation of likely weather patterns. This process creates annual hourly data (8,760 hours) that represents long-term local climatic trends. Energy plus weather data (EPW) is one of the most accessible types of this data available for many locations worldwide. EPW files are compliant with the most updated period of record from TMY2 and TMY3 datasets (Crawley et al., 1999). It contains wide variety of hourly data-fields including, wind speed (v), wind direction (α), atmospheric pressure (p) and dry bulb temperature (T). The data collection in weather stations takes place at a standard height (often 10 m) and terrain roughness of 0.03 m (Mertens, 2006). However, a BIWT is usually surrounded by an urban terrain different than standard terrain conditions where the weather data may be gathered. Also the turbine in BIWT is usually located at an elevation much taller than 10m. Thus, the data from EPW file cannot be directly employed for the calculation of energy production. In reality, in the absence of a practical technique for the measurements of the actual wind pattern at the required height, the alternative method is to extrapolate the wind velocity, angle and density from the surface data (EPW) to the BIWT situation. Sections 1.4, to 1.6 review the mathematical models used for the data extrapolation.

1.4. Hourly Wind Velocity at the Location of a Turbine

The following method is used by this study to provide adjusted wind velocity at the BIWT height from the surface data. To begin, the internal boundary layer (IBL) height and displacement height should be defined. The indicated parameters used later in the Log Law equation to calculate velocity at a given height (v_z).

IBL height: An abrupt change in the surface roughness (i.e. a city edge) creates a new boundary layer downwind of the step roughness (Fig. 2). It is called Internal Boundary Layer (IBL) and grows flowing forward. The effect of IBL is not present in the whole atmosphere but is limited to the height of IBL (h_k). Assuming the immediate roughness is $z_{0,1}$, faraway roughness $z_{0,2}$, maximum of $z_{0,1}$ and $z_{0,2}$ is $z_{0,max}$ and distance from step roughness is x , Equation [2] estimate the IBL height (h_k) (ESDU82026, 2008; Mertens, 2006).

$$h_k(x) = 0.28 \cdot z_{0r} \left(\frac{x}{\max(z_{0,1}, z_{0,2})} \right)^{0.8} \quad \text{where } [z_{0,max} = \text{Maximum of } z_{0,1} \text{ \& } z_{0,2}] \quad [2]$$

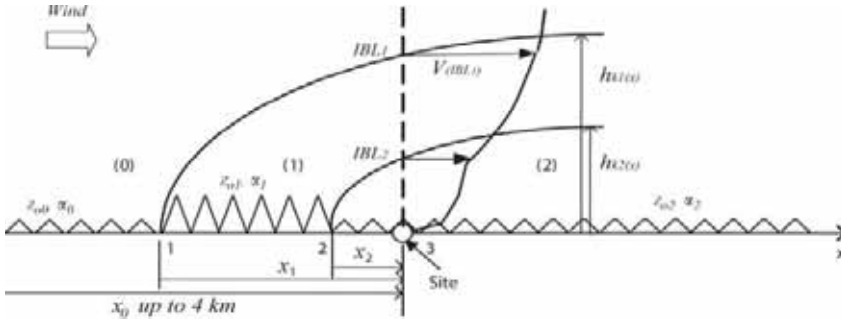

Figure 2: Internal Boundary Layers (IBL) above a Fetch, adopted from (Wang and Stathopoulos, 2007)

Displacement Height: Measurements of the velocity profile over a very rough terrain such as urban regions indicates a vertical displacement of the entire flow regime for those surfaces (Emeis, 2012). The displacement height (d) for the surfaces with low roughness is negligible, and would be disregarded. However, for the case of a typical city, d is approximately estimated around 23m (ESDU82026, 2008; Mertens, 2006)

Log law: To extrapolate the surface wind speed data to an alternative site (with diverse terrain condition and height), Sathyajith (2006) makes a logical assumption that velocity is not noticeably influenced by the terrain characteristics above a certain height. Thus, the velocity for a new location can be found by matching the velocities of the reference site and the new location at that height. For low roughness, this height is taken 60m above the ground (Lysen, 1983). Thus, the log law results in Equation [3] when v_{z_R} and z_{0R} are velocity and roughness lengths at reference site (e.g. EPW data) and $v_{(z)}$ and z_0 are velocity and roughness length at the new location respectively, (Mertens, 2006; Sathyajith, 2006). Per section 1.3, the EPW standard condition is $z_R = 10m$ and $z_{0R} = 0.03m$, so the original log law yields it new form in Equation [3] (Mertens, 2006).

$$v_z = \frac{\ln(60/z_{0R}) \ln(z/z_0)}{\ln(60/z_0) \ln(z_R/z_{0R})} v_{z_R} \quad \text{yields} \quad v_z = 1.31 \frac{\ln(z/z_0)}{\ln(60/z_0)} v_{z_R} \quad [3]$$

Log law for High roughness: For a city or a very rough terrain, the wind may experience multiple step roughness from the standard terrain of the weather station (z_{0R}) to the roughness of surrounding suburban regions (z_{01}) and the roughness of the city itself (z_{02}) see Figure 2. By matching the velocity above and below IBL height $h_k(x)$, the velocity profile in IBL_2 can be calculated by surface reference velocity from EPW file, therefore the Equation [3] evolves to Equation [4] (Mertens, 2006; Sathyajith, 2006).

$$v_z = 1.31 \frac{\ln(h_k/z_{01}) \ln([z-d]/z_{02})}{\ln(60/z_{01}) \ln([h_k-d]/z_{02})} v_{z_R} \quad [4]$$

1.5. Hourly Air Density at the Location of a Turbine

Per Equation [1], air density (ρ) is directly proportional with Turbine output energy. The surface air density (ρ_0) can be estimated using Ideal gas Law as illustrated in Equation [5], (U.S. Standard Atmosphere, 1976).

$$\rho_0 = RT/p \quad [\text{where } T \text{ is } ^\circ K = (^\circ C + 273.15)] \quad [5]$$

Where T is absolute dry bulb temperatures in $^\circ K$ (note that temperature in EPW file is provided in $^\circ C$), R is universal gas constant for air ($R = 8.31432 J/mol \cdot ^\circ K$) and p is atmospheric pressure obtained directly from EPW weather data. However, both p and T change as function of altitude. The U.S. Standard Atmosphere 1976 provides another equation based on Ideal gas Law and changes of p and T that is called Barometric formula as shown in Equation [6], where $\Gamma_e = \sim 6.5^\circ C/km$ is environmental lapse rate of temperature, and $g = 9.80665 m/s^2$ is gravitational acceleration (U.S. Standard Atmosphere, 1976).

$$\rho = \rho_0 \left(\frac{T_0}{T_0 + \Gamma_e \cdot (H - H_0)} \right)^{\left[\frac{g}{R \cdot \Gamma_e} \right] + 1} \quad [6]$$

2.0 BUILDING INTEGRATED WITH WIND TURBINE (BIWT)

BIWT refers to wind turbines that operate in a wind concentrated by a building. The integration method of turbines and buildings includes top, side and duct installation and installation between multiple towers

(Stankovic et al., 2009, P22). Mertens (2006) has done an aerodynamic investigation on wind energy production in the built environment. The study provides remarkable mathematical methods for quick estimation of BIWT power coefficients for three BIWT typologies including turbines at the buildings' roof, airfoil concentrators and bluff concentrators. These Mathematical formulas are partially validated using CFD analysis and wind tunnel testing. This paper focuses only on airfoil and bluff concentrators from his study.

2.1. Bluff Concentrator

The mathematics presented here, are borrowed from Mertens (2006 pp. 124-138) to explore the performance of a turbine placed between twin bluff shape buildings. Bluff bodies are characterized by early and quick flow separation from the body surfaces. An adverse pressure gradient between upwind and downwind surfaces induces flow velocity in connections or ducts between high and low pressure areas (Figure 3 and 4).

Jet contraction: When flow is crossing a sharp edge nozzle, the jet diameter is often less than the nozzle diameter. This is the result of the fluid inability to turn the sharp corners. The ratio between the smallest flow area and the nozzle area is called jet contraction coefficient ($\beta = A_t/A_f$) as shown in figure 3. Also, the flow around the axi-symmetric plate concentrator is displayed in Figure 4.

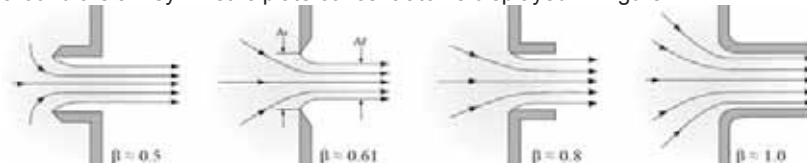

Figure 3: Jet Contraction (β) for Different Edge Configuration. Adopted from (Munson et al, 2009)

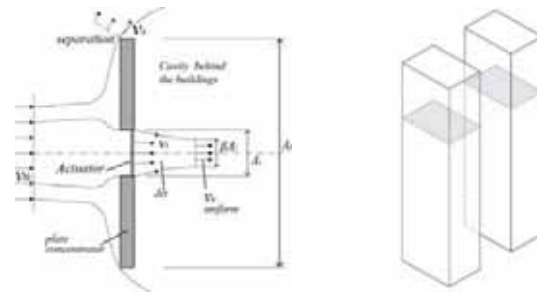

Figure 4: The Plate Concentrator in Axial Parallel Flow (Plan view). Adopted (Mertens, 2006)

According to Mertens (2006), power coefficient of a bluff concentrator ($C_{p,Bluff}$) is obtain from Equation [7].

$$C_{p,bluff} = \frac{2\beta}{3\sqrt{3}} \left(\frac{v_s}{v_0}\right)^3 \tag{7}$$

Where v_s separation velocity (see Fig. 4), v_0 is ambient wind velocity and β is Jet contraction (see Fig 3). As wind approaches a building, the surrounding flow patterns are noticeably dependent on the dimensional ratio of the building / BIWT form. The bodies with similar lengths in three dimensions deflect flow in all three dimensions (3D bodies). But, for the bodies with one length noticeably larger than other dimensions, as found with tall buildings, tend to deflect the flow on a 2D plane over the building's smaller section (Abdolhossein Pour, 2014; Hoerner and Borst, 1975). Mertens (2006) indicates that for 2D bluff bodies $v_s/v_0 \approx 1.3$ while for 3D bluff bodies $v_s/v_0 \approx 1.2$. Accordingly, Equation [7] for a tall BIWT (2D body) with rounded edges ($\beta = 1$) gives $C_{p,bluff} = 0.85$. Mertens measurements, reports a 30% reduction in $C_{p,bluff}$ for yawed flow of $\varphi = 45^\circ$. The profile of Bluff concentrator power coefficient is shown in Table 2 when $C_{p,0^\circ}$ and $C_{p,180^\circ}$ are power coefficients at $\varphi = 0^\circ$ and $\varphi = 180^\circ$.

Table 2: Normalized Power Coefficient as Function of Yaw Angle. Source (Mertens, 2006)

yaw angle (φ)	0°	45°	90°	135°	180°
Normalized $C_{p,bluff}$	$C_{p,0^\circ}$	$70\% C_{p,0^\circ}$	0	$70\% C_{p,180^\circ}$	$C_{p,180^\circ}$

2.2. Airfoil Concentrator (Shrouded Turbines)

The following section and equations, are borrowed from Mertens (2006 pp. 97-123) and investigates the performance of a BIWT with twin symmetrical airfoil shape concentrators (see Fig. 5). Mertens reports that a

shrouded turbine power coefficient ($C_{P,shroud}$) for a perpendicular flow is calculated from Equation [8], Where C_l is the Airfoils lift coefficient, c is the airfoils chord length, D_t is turbine diameter and X_s and X_a are correction factors and are obtained from Equations [9] and [10].

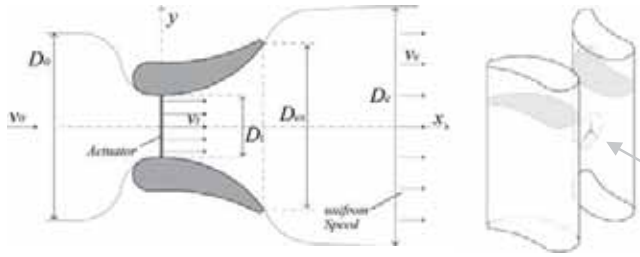

Figure 5: A Shrouded Configuration. Adopted from (Mertens, 2006)

$$C_{P,shroud} = \frac{16}{27} \left(\frac{X_a C_l c}{\pi D_t} \frac{1}{1 - \frac{X_s C_l c}{4\pi D_t \left(1 + \left(\frac{c}{2D_t}\right)^2\right)}} \right) \quad [8]$$

$$X_a = 0.5051 \ln\left(\frac{D_t}{2c}\right) + 1.4447 \quad \text{if } 0.2 \leq \frac{D_t}{2c} < 5 \quad [9]$$

$$X_s = \frac{1}{1 - 0.0511 \left(\frac{D_t}{2c}\right)^{-1.6211}} \quad \text{if } \frac{D_t}{2c} \geq 0.3 \quad [10]$$

However, $C_{P,shroud}$ from Equation [8] is valid only for perpendicular flows toward the building. In the case of yawed flow, $C_{P,shroud,\varphi}$ decreases as a function of the yaw angle (φ). Mertens reports, from Phillips, Flay, and Nash (1999), the measurements of $C_{P,shroud,\varphi}$ for yawed flow. The measurements indicated that the power coefficient is changing by φ but remain proportional to $C_{P,shroud,0^\circ}$ (perpendicular flow). Table 3 illustrates the ratio of power coefficient at different yaw angles normalized to $C_{P,shroud,0^\circ}$.

Table 3: Normalized Power Coefficient as Function of Yaw Angle. Source (Phillips et al., 1999)

yaw angle (φ)	0°	5°	10°	15°	20°	30°	40°	45°
Normalized $C_{P,shroud,\varphi}$	100%	100.4%	99.1%	91.5%	86.0%	80.8%	68.0%	62.5%

For range of $\varphi = 90^\circ$ to 180° , the sharp edge of airfoils results in early flow separation, so the flow across the airfoils effectively behaves like across bluff bodies (see section 2.1, bluff bodies). Accordingly the power coefficient for $\varphi = 90^\circ$ to 180° is calculated using Equation [7] and Table 2. As result $C_{P,shroud,90^\circ} = 0.77$ and $C_{P,shroud,180^\circ} = 0.85$, are not dependent of $C_{P,shroud,0^\circ}$, the airfoil shape and angle of attack and remain almost constant for different airfoil geometries.

2.3. Combined Concentrators

Airfoil and bluff BIWTs show relatively high sensitivity to yaw angle. This sensitivity greatly drops their annual output power for omnidirectional winds. Mertens (2006) proposes two identical bluff concentrators in cross configuration (See Fig. 6) to solve this problem. The idea is denoted as the *combined concentrator* in this paper. This configuration is proposed in an attempt to significantly increase C_p for $\varphi = 90^\circ$ & 270° (see Figure 6). Since sharp edges buildings are expected to be inefficient, Mertens focuses only on airfoil shapes buildings for combined concentrators. The combined concentrator power coefficients are shown in Table 4.

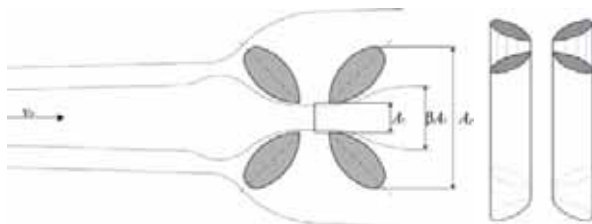

Figure 6: Combined Plate Concentrator at $\varphi = 45^\circ$. Adopted from (Mertens, 2006)

Table 4: Power Coefficient as Function of Yaw Angle. Source (Mertens, 2006)

yaw angle (φ)	0°	45°	90°	135°	180°
$C_{p,combined}$	0.51	1.01	0.51	1.01	0.51

3.0 CASE STUDIES

Three case studies are presented below in sections 2.1 to 2.3 and summarized in figure 7. Also, the turbine diameter, the tower's height, the turbine height, as well as the number of the floors are assumed to be constant and equal to 30m (98.5ft) and 250m (820ft), 200m (656ft) and 65m respectively for all cases. Hence, variations in the results are purely due to the BIWT power coefficient and the weather data and BIWT direction.

- **Airfoil Concentrator:** For this case study the selected shape is GOE435-il with $C_L = 1.7543$ at attack angle (α) of 17.5° and $c = 50\text{m}$ (164ft) (Airfoil Tools, 2013)¹.
- **Bluff Concentrator:** This case study uses twin towers with dimension 60m by 35m (197ft by 115ft) for each tower, figure 7, middle. The floor depth of 35m (115ft) gives a lease span of about 13m (40ft) as well as 40ft for a central core. The front and back inlet edges are chosen to be well rounded ($\beta_1 = \beta_2 = 1$).
- **Combined Concentrator:** This case study is composed of four towers in a cross configuration. Each tower is a symmetrical airfoil with a chord length of 60m (197ft) and thickness of 27.5m (90ft).

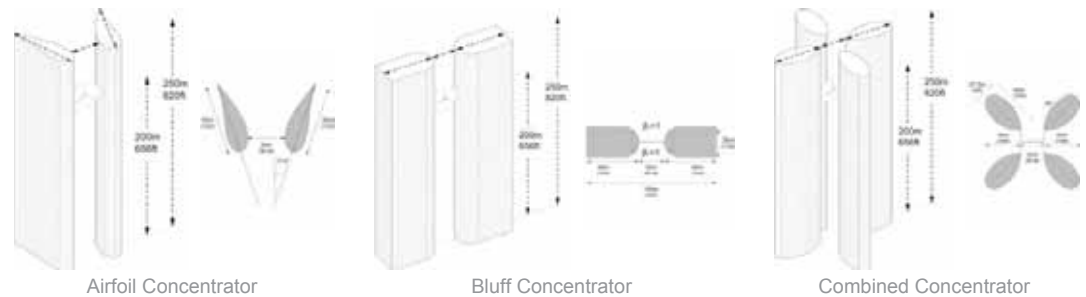

Figure 7: Three BIWT case studies, corresponding to the three BIWT typologies in sections 2.1, 2.2, and 2.3

The profile of power coefficients for each case study has been calculated using the data and mathematical equations provide in sections 2.1 to 2.3. This part of the analysis is denoted as “Steady state analysis”. The power coefficient profile for three case studies are illustrated in Figure 8. For perpendicular flow, $C_{p,shroud,0^\circ}$ (Fig. 8, right) is highest among the case studies. However, both airfoil and bluff concentrators (figure 8, right and middle) show a relatively high sensitivity to the wind angle. The combined concentrator shows lower power coefficients in all directions comparing $C_{p,shroud,0^\circ}$ but characterizes minimum sensitivity to the yaw angle. The best BIWT case study, is the one capable of maximizing energy production. Nonetheless, with only a steady state power coefficient, it is still not possible to predict which option will produce more energy.

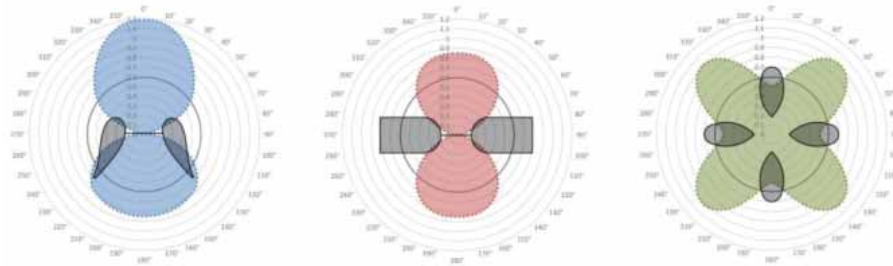

Figure 8: Three BIWT case studies, corresponding to the three BIWT typologies in sections 2.1, 2.2, and 2.3

The next step of the study is applying annual hourly weather data in the calculation of annual energy production, denoted as “hourly dynamic analysis”. Incorporation of steady state (Figure 8) and hourly dynamic analyses results in the calculation of annual energy production. To test the usefulness of this methodology four cities were selected for study based on wind speed and the wind angle distribution profile. The cities are intentionally chosen with diverse wind patterns, latitudes and climates so, the influence of weather data on annual energy enhancement of each BIWT typology is exemplified. The selected cities are Chicago, New York, Berlin and Abu Dhabi. Their wind patterns are shown in Figure 9.

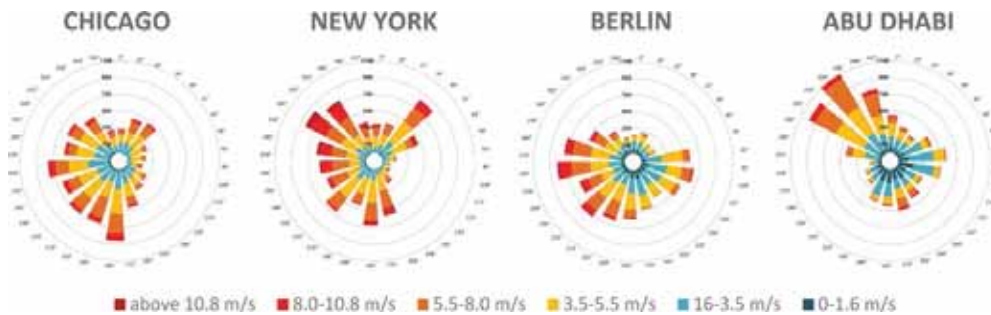

Figure 9: Wind Rose at the Ground and the Turbine Height

3.2. BIWT Orientation (Azimuth)

Assuming hourly wind angle and BIWT orientation measured clockwise from North are respectively α_w and θ , the wind yaw angle of BIWT (φ) is obtained from $\varphi = \alpha_w - \theta$. So φ depends on both θ and α_w . So, It is also important to study the effect of BIWT alignment (θ) on the total annual energy enhancement. In this study, the annual energy production of BIWT is obtained for 36 direction in 360° , while θ was changing in 10° increments.

3.3. Algorithmic Procedure of the Study

The study was further developed through the application of hourly annual weather data (EPW file) for the calculation of annual energy production of the three indicated case studies in each city for each angular increment of θ . The hourly power production of a BIWT is obtained from substitution of the Equations [4] and [6] and as well as results from tables 2, 3 and 4 into Equation [1]. The hourly energy production of a BIWT, thus, is obtained from Equation [11] where, T is the period of time and equal to 1 hour for hourly data (EPW).

$$E_T = \frac{1}{2} C_{p\varphi} \cdot \rho_z \cdot v_z^3 \cdot A_t \cdot T \quad [11]$$

The following steps have been done for each case study in each city.

- Step 1. BIWT direction is assumed toward north for all case studies ($\theta = 0^\circ$)
- Step 2. Extrapolation of wind velocity for the BIWT height using Equations [3] or [4] from the surface data
- Step 3. Calculation of air density for the BIWT height using Equation [6]
- Step 4. Calculation of power coefficient profile for three BIWT case studies as shown in Figure 9.
- Step 5. Substituting the results from last 3 steps in Equation [11] to obtain hourly energy (E_t)
- Step 6. Summation of Hourly result over a year is annual energy output of the BIWT ($E_{BIWT} = \sum_{T=1}^{8760} E_T$)
- Step 7. E_{BIWT} is obtained assuming BIWT direction is θ at step 1
- Step 8. Modifying the BIWT direction incrementally with 10° increment, and redo the steps 2 to 7

The last step of the proposed methodology uses an algorithmic process to produce an optimization loop of with array of 36 analysis scenarios for each BIWT/City while θ is incrementally changing. At step 8, θ increase by 10° and the whole calculation process is repeated for new value of θ . Analysing 3 case studies in four cities at 36 angles give the total of 432 annual energy production measurements for this study. Each array of 36 studies creates the annual energy production profile of a BIWT/City as a function θ shown as a radar or circular charts for three case studies and 4 cities in Figure 10. Each colour corresponds to one BIWT typology.

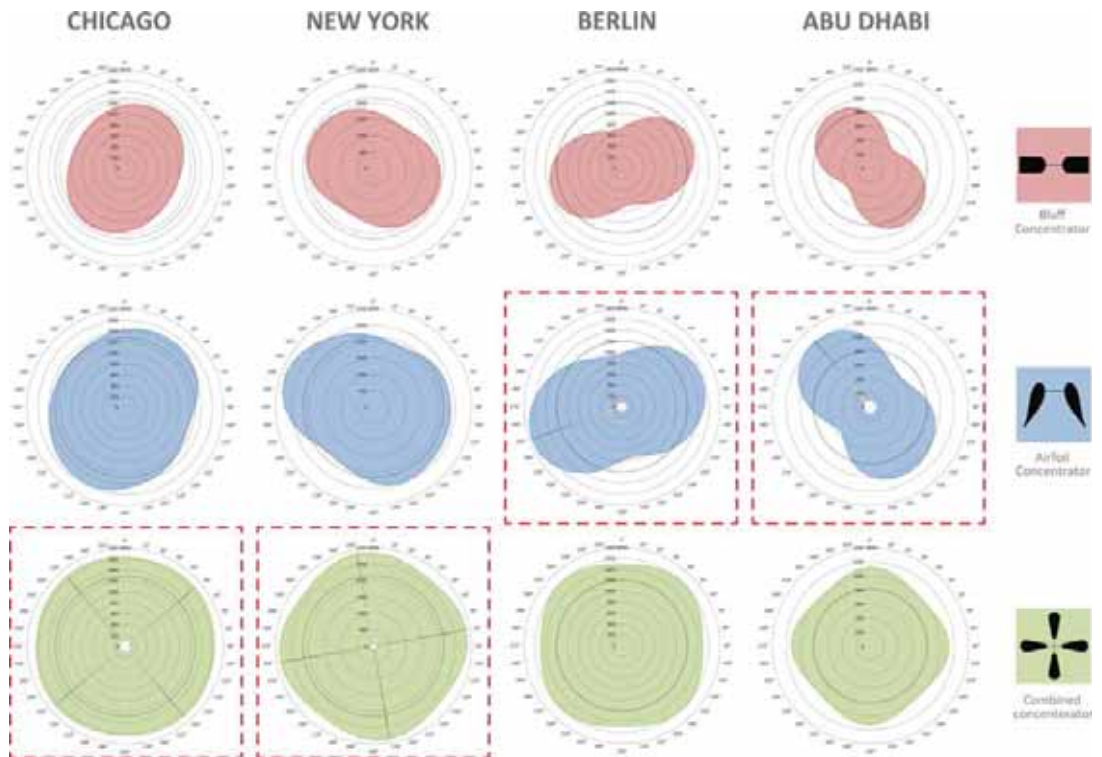

Figure 10: Energy production profile as functions BIWT alignment, the most efficient BIWT in each city is shown in a dash line rectangles. Also the best orientation of BIWT is shown with white arrows.

3.4. Analysis of the Results

Surprisingly, the peak production came from the “Combined Concentrator” located in New York. Similarly, Chicago’s best BIWT typology was the “Combined Concentrator” too (Fig. 10). Berlin and Abu Dhabi benefited most from the “Airfoil Concentrator” configuration. In all cities, the “Bluff Concentrators” produced less than other BIWT typologies. In general, a concept with an excellent performance in one city might not

be appropriate for another city depending on the local pattern of wind velocity and angle. For instance, cities like Chicago that do not have a dominant wind direction, the omni-directional concept (Combined Concentrator) works better though it shows lower power coefficient. For a place with dominant wind direction, like Abu Dhabi, the Airfoil concentrator shows the best performance out of the three configurations studied.

3.5. Conclusion

This paper demonstrates the application of a methodology which accounts for local wind and terrain conditions that impact the annual power output of a BIWT. The case studies presented, indicate, it is possible that a BIWT with lower power coefficient produce more annual energy depending on specific terrain conditions, local annual wind pattern, power coefficient of BIWT and its sensitivity to the yaw angle. It can be concluded that power coefficient is not the only parameter influencing the ultimate BIWT energy production. Thus, the use of power coefficient to inform the architectural design process of BIWT, while disregarding other important parameters (e.g. local weather data, terrain condition) might be misleading for the design team. The "Algorithmic Procedure" described briefly in section 3.3, is part of an ongoing research and tool development for an accurate and quick estimation of BIWTs' annual energy improvement in early design stages. The final decision on the use of BIWT should be made by the design team based on all associated design criteria and cannot be prescribed before the design process starts. Thus, the proposed tool for identifying the best BIWT typology and its optimum angle can possibly be an important part of a BIWT design process. As a result, the design team take the right direction when there is still time for extensive modifications in building architecture.

ACKNOWLEDGEMENTS

Sincere gratefulness to Dr. Dietmar Rempfer, Professor of aerospace engineering, and Dr. Hamid Arastoopur, Professor of chemical engineering at Illinois Institute of Technology, for their supports during this research.

REFERENCES

- Abdolhossein Pour, F. (2014). *Evaluation of Tall Office Building Form to Enhance Wind Energy Production in Building Integrated Wind Turbine, a Performance Based Approach for Early Design Stage*. (Ph.D. Dissertation), Illinois Institute of Technology, Chicago.
- Airfoil Tools. (2013). *Airfoil Tools*. Retrieved October 1, 2013, from <http://airfoiltools.com>
- Babsail, M. O. (2011). *Toward Net Zero Energy: The Correlation between Architectural Forms of Tall Buildings and Wind Power Production*. (Ph.D. Dissertation), Illinois Institute of Technology.
- Campbell, N. S., and Stankovic, S. (2000). *Wind Energy for the Built Environment. (Project WEB). Assessment of Wind Energy Utilisation Potential in Moderately Windy Built-up Areas*. London BDSP Partnership.
- Crawley, D. B., Lawrie, L. K., Winkelmann, F. C., W.F. Buhlc, Y. J. H., Pedersen, C. O., Strand, R. K., . . . Glazer, J. (1999). *EnergyPlus, A New-Generation Building Energy Simulation Program*. Paper presented at the Building Simulation '99, Kyoto, Japan.
- Emeis, S. (2012). *Wind Energy Meteorology: Atmospheric Physics for Wind Power Generation*: Springer.
- ESDU82026. (2008). *Engineering Sciences Data Unit: ESDU International plc*.
- Hoerner, S. F., and Borst, H. V. (1975). *Fluid-dynamic lift: practical information on aerodynamic and hydrodynamic lift*, [information on lift and its derivatives, in air and in water]: Hoerner Fluid Dynamics.
- Lysen, E. H. (1983). *Introduction to Wind Energy: Basic and Advanced Introduction to Wind Energy with Emphasis on Water Pumping Windmills*: Consultancy Services Wind Energy Developing Countries.
- Manwell, J. F., McGowan, J. G., and Rogers, A. L. (2002). *Wind Energy Explained: Theory, Design and Application*: West Sussex, UK, Wiley.
- Mertens, S. (2006). *Wind Energy in the Built Environment: Concentrator Effects of Buildings*. (Ph.D Dissertation), Technische Universiteit Delft, Brentwood, Essex.
- Munson, B. R., Young, D.F., Okiishi, T.H., Huebsch, W.W. (2009). *Fundamentals of fluid mechanics*: Wiley.
- Phillips, D. G., Flay, R. G. J., and Nash, T. A. (1999). *Aerodynamic Analysis and Monitoring of the Vortec 7 Diffuser-Augmented Wind Turbine*. IPENZ Transactions, 26(1), 13-19.
- Sathyajith, M. (2006). *Wind Energy: Fundamentals, Resource Analysis and Economics*: Springer.
- Stankovic, S., Campbell, N., and Harries, A. (2009). *Urban Wind Energy*: Earthscan.
- U.S. Standard Atmosphere*. (1976). National Oceanic and Atmospheric Administration, National Aeronautics and Space Administration, US Air Force
- Wang, K., and Stathopoulos, T. (2007). *Exposure model for wind loading of buildings*. Paper presented at the The Fourth European and African Conference on Wind Engineering, Journal of Wind Engineering and Industrial Aerodynamics.

ENDNOTES

¹ The website's offer a database of 1629 airfoils, searchable by name, thickness and camber. The lift coefficient data as a function of attack angle is available for most airfoil within the database.

Bamboo-steel composite structures

Rui Liu¹, Yushun Li²

¹Kent State University, Kent, OH
²Ningbo University, Ningbo, China

ABSTRACT: Environment-friendly construction materials and intelligent designs are necessary to maintain sustainable development of human society. Bamboo has high strength to weight ratio, and it is renewable and biodegradable. It has great potential to be used as a structural material once its limitations of application (e.g. dimensional instability, difficult connections, and inadequate bonding) are addressed. With advanced knowledge in material science and new technologies, laminated bamboo plywood, also called ply-bamboo, can be fabricated through the process of crushing, hot-pressing, adhesive spreading and gluing, cold-pressing, and curing. The bamboo plywood has stable dimensions and it is hydrophobic, and resistant to fungi and bacteria attack. Bamboo-steel structural members are composed of laminated bamboo plywood made from moso bamboo and cold-formed thin-walled steel sheet, which are bonded by structural adhesive and strengthened by screws. The cross section of a structural member with large radius of gyration and moment of inertia is easily formed using thin-walled steel sheet with less steel, but the structural member inclines to buckle globally and locally with increased width to depth ratio of the section. The laminated bamboo plywood is bonded to the surface of the steel sheet to keep the stability of the cross section. Various light weight bamboo-steel composite structural systems have been developed through several sponsored research projects e.g. slabs, walls, columns, and beams. Lab testing has indicated excellent performances of the structural members. This paper introduces the fabrication of the bamboo-steel composite slabs, walls, columns, and beams, summarizes the findings from the lab testing to evaluate their structural performance, and discusses the design methods to determine the load bearing capacities of the structural members.

KEYWORDS: Bamboo Plywood, Cold-Formed Thin-Walled Steel Sheet, Composite Structures

INTRODUCTION

Sustainable development is an enormous challenge facing the seven billion people who are living on the earth. As a huge source of carbon emission and energy consumption, construction sector should be handled responsively to the natural environment and human society. Environment-friendly construction materials need to be carefully selected and applied with the intelligent design to "*satisfy the present needs without compromising the ability of future generations to meet their needs* (Brundtland, 1987)". Characteristics of sustainable construction materials include high recycled and recyclable contents, rapid renewable and biodegradable products, regionally available resources, etc. Bamboo, a collection of giant grass species, has already attracted considerable attentions of architects, engineers, and researchers from all over the world as a sustainable construction material.

Among 1,250 species of bamboo in the world, many can reach 15 meters (49 feet) high within 2 to 4 months, and the diameters of the plant can reach 15 centimeters (5.9 inches) within 3 to 8 years (Liese,1987; Lee et al, 1994). *Phyllostachys pubescens*, known as Moso bamboo, native in China, and *Guadua angustifolia*, known as Guadua bamboo, native in South America, are two most commonly cultivated species for structural purposes. It is interesting to notice in many Asian countries where bamboo is native, bamboo has already been used for structural purpose in building industry. But in the U.S. and the European countries, bamboo is commonly used in non-structural applications e.g. floor board, furniture, etc for ornamental purposes. Possibly this is because in many western countries, structural bamboo is not as widely available as wood, but it is totally opposite in many developing countries. Actually, structural bamboo possesses many mechanical properties superior to those of wood products. Table 1 compares strength and modulus of elasticity of moso bamboo culm with that of a dimension lumber made from southern pine in the US. In addition, comparing with other conventional materials such as wood, steel and concrete, bamboo has high strength/stiffness to weight ratios, shown in Figure 1.

Table 1: Strength and modulus of elasticity of moso bamboo culm compared with southern pine.

Material	Tension		Compression		Bending		Shear		Modulus of Elasticity					
	parallel to grain		parallel to grain				parallel to grain		Tensile parallel to grain		Compressive parallel to grain		Bending	
	MPa	psi	MPa	psi	MPa	psi	MPa	psi	MPa	psi	MPa	psi	MPa	psi
Moso bamboo culm ^a	191	27,688	65	9,442	149	21,596	18	2,654	11,400	1,653,430	6,370	923,890	11,600	1,682,437
Southern Pine ^b (Dense select structural)	11	1,650	16	2,250	21	3,050	1	175	13,100	1,900,000	4,757	690,000	13,100	1,900,000

^a Data from Li et al (2007); ^b Data from National American Wood Council (2005); ^c minimum modulus of elasticity

Bamboo has a great potential to be used in building construction as a structural material. van der Lugt et al (2006) performed a life cycle analysis to evaluate the environmental impact of utilizing moso bamboo shipped from Shanghai, China to Rotterdam, Netherland, in construction, and concluded the bamboo could be used as a sustainable building material for western countries within certain boundary conditions. However, the bamboo swells once it absorbs moisture, it is difficult to connect bamboo members due to the hollow tube shape, and the bamboo culm is prone to fungi and bacteria attack. Therefore, it is of interest to develop laminated bamboo lumber or bamboo plywood, also called ply-bamboo (Janssen, 2010), by gluing bamboo strands or flattened surfaces taken from the bamboo culm to create shapes more suitable for modern structural applications.

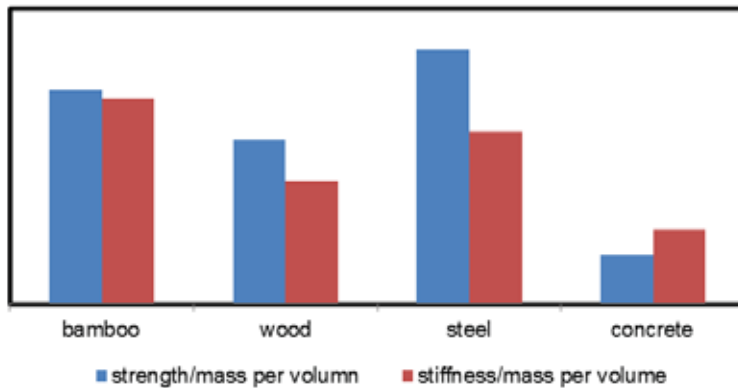

Figure 1: Strength and stiffness of different materials (adapted from Janssen, 2000).

Mahdavi et al (2011) reviewed three processing techniques to manufacture laminated bamboo products, and discussed the challenges and viability of using laminated bamboo lumber as an alternative structural material in North America. Mahdavi et al (2012) developed a low-technology approach using hand tools and economical adhesives to fabricate a laminated bamboo lumber which is suitable for use in building construction. Li et al (2012) investigated the technique of processing moso bamboo culm into laminated bamboo plywood through crushing, hot-pressing, adhesive spreading and gluing, cold-pressing, and curing. The end product has a normal thickness of 10 mm (0.39 inch) to 25 mm (1 inch). With advanced knowledge in material science and new technologies, as well as development of structural adhesives, the fabricated laminated bamboo plywood overcomes the disadvantages of bamboo culm. It is dimensional stable, hydrophobic, and resistant to fungi and bacteria attack. However, this product is usually used for concrete formwork or other applications in low technological end in China. On the other hand, thin-walled steel sheets are easily cold-formed to a cross section with a large radius of gyration and moment of inertia. Comparing to standard steel sections, the structural members formed using thin-walled steel sheet are much lighter, consuming much less steel, and they have been applied as roof rib beams, floor beams, wall supporting structure, etc. But the cold-formed thin-walled steel structural members incline to lose its global and local stability with increased width to depth ratio. To address this problem and take advantage of the economic value created by laminated bamboo plywood, the bamboo-steel composite structures are engineered by bonding the laminated bamboo plywood to the surface of the steel sheet.

Various light weight bamboo-steel composite structural systems have been developed through several sponsored research projects e.g. slabs, walls, columns, and beams. Lab testing has indicated excellent performances of the structural members. This paper introduces the fabrication of the bamboo-steel composite slabs, wall, columns, and beams, summarizes the findings from the lab testing to evaluate their structural performance, discusses the design methods to determine the load bearing capacities of the structural members.

2.0 FABRICATION OF BAMBOO-STEEL COMPOSITE STRUCTURES

2.1. Materials

Moso bamboo plywood was used in the fabrication of all composite structures in this paper. The zephyr strand mats were produced by crushing moso bamboo culms using a roller crusher. After hot-pressing between 150°C and 180 °C to achieve a stable dimension, and removing inner and outer layers of the mats, the mats were glued together using a resorcinol-formaldehyde resin. The fabricated panels were cold-pressed for several hours until all layers were fully bonded and then cured at least two weeks at 25°C and 65% relative humidity (Li et al, 2012). The bond created by the structural glue is resistant to water, as well as chemical and biological attacks. The modulus of elasticity (MOE) and modulus of rupture (MOR) of eight bamboo plywood samples were measured according to ASTM D 4761 and listed in Table 2. Table 3 shows

the MOE and MOR of common construction materials. The bamboo plywood is more flexible and stronger than the Douglas-Fir dimension lumber. It is expected the lifetime of the laminated bamboo plywood is equivalent to or even longer than the lumber and glued laminated wood products. The MOE and MOR of a typical structural steel are 200,000 MPa and 400 MPa respectively. The MOR to MOE ratio of steel is 0.002. For bamboo plywood, the ratio is 0.0064 (Table 2). This means bamboo plywood has larger deformation capacity than structural steel when rupture occurs. When the two materials are bonded together, the strength of the steel can be fully developed if the bonding does not fail. At the end of life, landfill of the bamboo plywood does not cause environmental concerns because of its biodegradability.

Table 2: Mechanical properties of bamboo plywood

Bamboo Plywood	MOE		MOR	
	MPa	psi	MPa	psi
Mean	5896	855,142	96.5	13,996
Standard deviation	412	59,756	6.65	965
Coefficient of variation	0.070		0.069	

Table 3: Mechanical properties of common construction materials (Mahdavi et al, 2011)

	MOE		MOR	
	MPa	psi	MPa	psi
Douglas-Fir	13600	1,970,000	88	12,760
Aluminum Alloy	69,000	10,005,000	200	29,000
Structural Steel	200,000	29,000,000	400	58,000

The cold-formed thin-walled steel sheet used for the manufacture of composite structures has a nominal MOE of 206 GPa (29,878 ksi), a nominal yield strength of 235 MPa (34 ksi), and a nominal ultimate tensile strength of 375 MPa (54 ksi). The thickness of the steel sheet ranges between 1 mm (0.0039 in) to 2 mm (0.079 in). The steel sheet can be recycled into another product at the end of its life.

The bamboo-steel composite structures are composed of bamboo plywood and cold-formed thin-walled steel sheet bonded by structural adhesive, and strengthened by self-tapping screws (enhanced connection). The enhanced connection minimizes the slippage at the interface of the two materials due to external forces or temperature change. The structural adhesive is a common rapid curing and high strength epoxy resin used for bonding metal, wood, and other construction materials. The amounts of structural adhesive used in various composite structural members are discussed in Section 3.0. Zhang et al (2015) developed a theoretical model to evaluate the performance of pure adhesive bonding of the bamboo-steel composite structure. The authors of this manuscript are investigating the bonding strength and slippage of the enhanced connection under the short term and long term static loads. Fabrications of the composite structural members will be discussed in the following sections. Composite slabs, walls and columns have hollow cross section, which can be filled with different materials for insulation or sound-proofing. In addition, the electric wires, cables, or pipes easily pass through these hollow structural members.

2.2. Bamboo-steel composite slab

The bamboo-steel composite floor slab is composed of two pieces of bamboo plywood attached to the flanges of cold-formed thin-walled steel channels, which is shown in Figure 2(a). The flexural behaviors of six slabs with three different types of connections were evaluated by Li et al (2012). The slabs were 0.9 m X 0.33 m X 3 m (2.95 ft X 1.08 ft X 9.84 ft) and the two steel channels were spaced 0.45 m in the middle. Three specimens had simple adhesive connection between the bamboo plywood and the flange of steel channel. One specimen had adhesive connection strengthened by screws. The other two used the bamboo laths to improve the stability of the steel channel by attaching them to both sides of the channel (Figure 2b).

The lab testing indicated the bending capacity, stiffness and stability of specimens were improved by enhanced connection and bamboo laths. The slabs with this type of connection exceeded the structural requirements of floor slabs. Enhanced connection with bamboo laths are recommended for the construction. Strain gages were attached to the steel channel and the bamboo plywood to measure the deformations of the materials. The testing results showed both materials were in the elastic range before rupture occurred. The interface of the recommended connection performed well. Large deformation of the slab was the warning sign of rupture. Therefore, a transformed-section method was proposed by Li et al (2012) to analyze the deformation and bearing capacity of the whole member. The cross-section area of bamboo plywood was transformed to the equivalent area of steel to determine the stiffness of the whole section. The theoretical values predicted by the simplified calculation matched the testing results well. This method can be used in the design of the composite structure.



(a) Slab

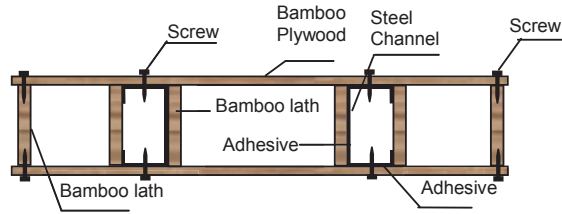

(b) Cross Section

Figure 2: Bamboo-steel composite slab.

2.3. Bamboo-steel composite wall

Two types of composite walls have been developed. The first type is used as building envelope and partition wall, shown in Figure 3. The other is designed to resist lateral forces i.e. wind and seismic loads. The fabrication of exterior or interior walls is illustrated in Figure 3 (b). Two 20 mm (0.79 in) thick bamboo plywood laths are glued to both sides of the cold-formed thin-walled steel channel to form the core of the wall. Then two pieces of bamboo plywood are attached to the top and bottom surfaces of the core. Thirteen specimens with two different insulation materials (glass fibers and polyurethane foam), various wall thicknesses, with/without extruded polystyrene board exterior insulation were evaluated for their thermal behaviors. The thermal conductivity of the composite walls with the two different insulation materials was between 0.145 and 0.387 $W/(m^2 \cdot ^\circ C)$. The specimens filled with polyurethane foam had better thermal performance than the specimens with glass fibers. The phenomenon of thermal bridge was observed at the location of cores. The effect could be weakened by applying the extruded polystyrene board exterior insulation system, which improved the insulation of the composite walls (Xu, 2012).



(a) Wall

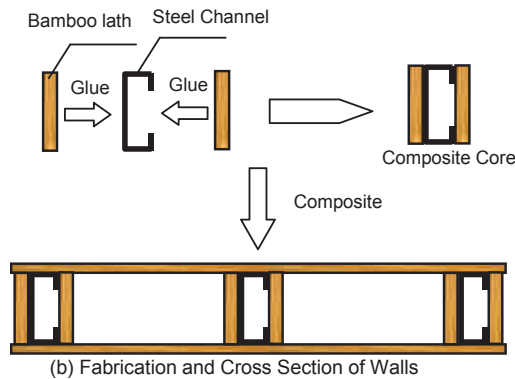

(b) Fabrication and Cross Section of Walls

Figure 3: Bamboo-steel composite wall.

The composite walls designed to resist lateral forces have similar cross section shown in Figure 3(b). But the interface between the bamboo plywood and the steel flange was strengthened by screws. A quasi-static testing was performed for six walls with various thicknesses of bamboo plywood and different sizes of steel channel to evaluate their failure mechanisms, seismic behaviors, and lateral force bearing capacities (Li et al, 2013). The thickness of steel sheet and the dimension of steel channel, rather than the thickness of bamboo plywood, determine the seismic behavior and the lateral load bearing capacity of composite walls. The composite walls exhibited good ductility and could dissipate seismic energy. The lateral load bearing capacity of the wall was contributed by the composite core and the bamboo plywood. Both members were bent to failure under the lateral force. The lab testing indicated the specimens had excellent composite performance, therefore it was assumed both the composite cores and the bamboo plywood had same deformation at the connections before rupture. According to the transformed-section method, the lateral load bearing capacity of the composite wall could be established by transforming the cross section area of bamboo plywood to an equivalent area of steel, also assuming the steel yields when rupture occurs. Composite walls with profiled steel sheet in the center of the wall were also evaluated for their seismic

behaviors (Li et al, 2010). But their performances were not as good as the walls with composite cores. It's recommended to use the walls illustrated in Figure 3 in the construction.

2.4. Bamboo-steel composite column

The composite column with a hollow square shape is shown in Figure 4. The fabrication is relatively easy. The bamboo plywood is attached to the web and flanges of two pieces of cold-formed thin-walled steel channels by structural adhesive and strengthened by screws. The performance of the columns under axial compression was tested by Xie et al (2012) to explore their failure mechanism and axial load carrying capacities. The testing shows the specimens failed due to the debonding of the connection between bamboo plywood and steel, and the local buckling at the web of steel channel. But before the rupture occurred, specimens exhibited good composite effect.

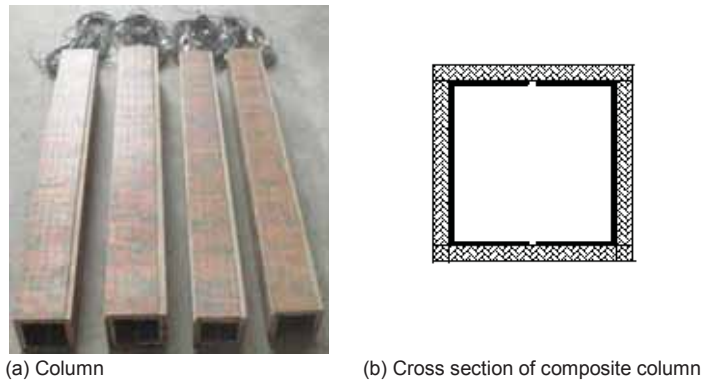

Figure 4: Bamboo-steel composite column.

2.4. Bamboo-steel composite beam

The cross section of the bamboo-steel composite beam is composed of three pieces of bamboo plywood and two cold-formed thin-walled steel channels. The two steel channels are glued to the central bamboo plywood, and then two pieces of bamboo plywood are attached to top and bottom of the section. The failure mechanisms, failure modes, deformations, shear and bending bearing capacities of nine composite beams were investigated by Li et al (2011), in order to understand the influence of flange thickness, web width, thickness of steel sheet, overall sectional dimensions, and ratio of shear span to depth on flexure and shear behaviors of composite beams. As the loading increases, the beam went through elastic, elastic-plastic, and failure, three stages. The nominal bending and shear capacities were determined by the maximum load in the elastic range carried by the composite beam, which is approximately 30-50% of the ultimate load. Debonding of the two materials, local buckling and yielding of the steel occur in the elastic-plastic and failure stages. Higher bearing capacity and stiffness could be provided by thicker bamboo plywood and steel channels. The cross section area and the ratio of shear span to depth are main contributors to shear capacities of the composite beams. The beams exhibited excellent composite effect in the elastic range. Therefore, simplified models were proposed based on transformed-section method and superposition principle. The nominal bending and shear capacities of the beams determined from the models matched well with the experimental values.



Figure 5: Bamboo-steel composite beam.

To connect the bamboo-steel composite structure members, regular steel connectors for wood and steel structures can be used. To strengthen the stiffness of the joint, a steel tube was designed by welding four steel plates around the core of the column and beam connection (Figure 6). Two steel “T” connectors were used to bolt the beam with the column. Li et al (2013) performed quasi-static tests on 6 composite beam-

column joints with or without stiffener to evaluate the ductility, energy dissipative capacity, and other seismic parameters of the joints with different numbers and grade of bolts. It showed the bolts had little effect on the performance of the joints, but the stiffener and the weld size controlled deformations at the core and ultimate load capacities of the joints. The special connection can be used at the exterior joints of a building to resist large lateral forces e.g. seismic load.



(a) Connection

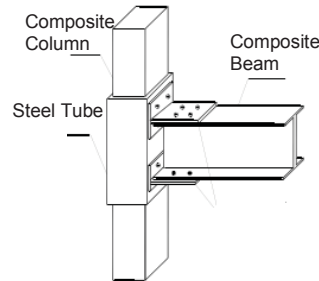

(b) Sketch of the connection

Figure 6: Connection for bamboo-steel composite beam and column.

3.0 CASE STUDY

A two story simple building with a floor plan shown in Figure 7(a) was designed to use the bamboo-steel composite structural system. Each story is 2.8 m high (9.2 ft). The following conservative parameters were assumed in the design:

- (1) Floor live load: 2 kN/m^2 (42 psf)
- (2) Dead load:
 - Walls and partition: 1.6 kN/m^2 (34 psf)
 - Ceilings, mechanical system, misc.: 1.5 kN/m^2 (33 psf)
- (3) Modulus of elasticity:
 - Bamboo plywood: 5.5 GPa (798 ksi)
 - Cold-formed thin-walled steel: 206 GPa (29,878 ksi)

According to the design methods for bamboo-steel composite structures proposed by corresponding research studies discussed above, composite slab, wall, column and beam were designed. The dimensions of cross sections are shown in Figure 7 (b). The thickness of steel sheet is 1 mm (0.039 in) for slab and wall and 2 mm (0.078 in) for column and beam. The flange widths of the steel channel in the slab wall, column and beam are 50 mm (1.97 in.), 60 mm (2.36 in.), 105mm (4.13 in.), and 70 mm (2.76 in.) respectively.

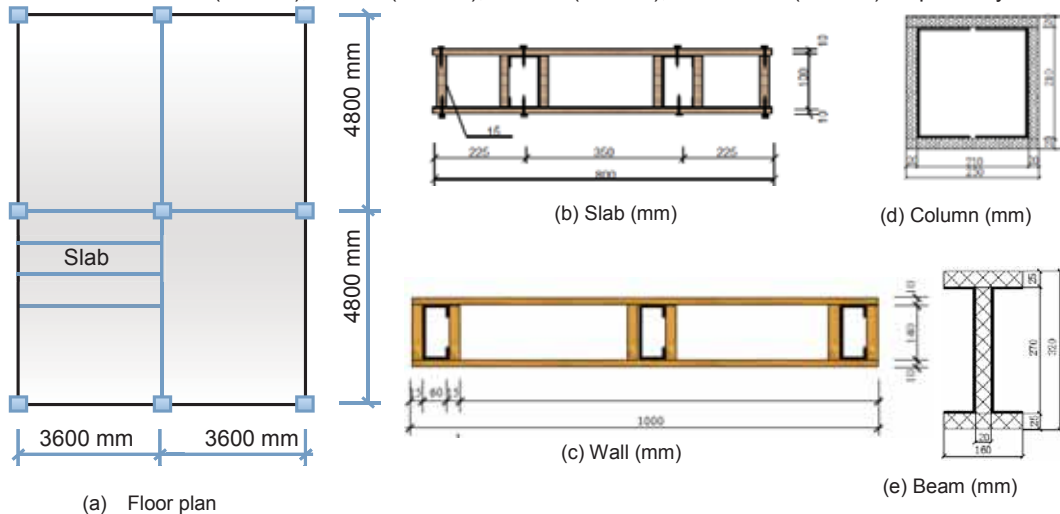

Figure 7: Floor plan of a simple building.

The bearing capacity of the composite structural members and the consumption of materials are summarized in Table 4. Shown in the table, structural adhesive accounts for only 1% of overall weight of the composite structures. Its environmental impact is not significant. Because of the regular shape of the cross section, the construction wastes can be minimized. The unit cost of bamboo plywood is \$488/m³ (\$13.59/ft³), unit cost of steel sheet is \$780/tonne (\$0.35/lb), cost of structural adhesive is \$6.5/kg (\$2.95/lb), and rate of application is 0.3 kg/m² (0.061 lb/ft²). The material costs of each slab, wall, column and beam are summarized in Table 5. The composite structures will be fabricated in China. The costs of the materials were converted from Renminbi to US Dollars. The composite structures have economic advantage, but the authors don't have specific data at this point to show the economic benefits of the bamboo-steel composite structure in terms of materials by comparing it with other conventional construction material. A comprehensive analysis for life cycle cost and environmental impact needs to be performed to measure and quantify the sustainability of the composite structures.

Table 4: Bearing capacity and materials consumption.

	Bearing Capacity		Volume of bamboo per specimen		Mass of bamboo per specimen		Volume of steel per specimen		Mass of steel per specimen		Mass of structural adhesive per specimen	
Slab	12.19 kN·m	8,991 lbf·ft	0.09 m ³	3.18 ft ³	67.5 kg	149 lbm	0.0017 m ³	0.060 ft ³	13.6 kg	30 lbm	0.71 kg	1.56 lbm
Wall	475 kN	107 kipf	0.078 m ³	2.75 ft ³	58.9 kg	130 lbm	0.0024 m ³	0.085 ft ³	18.7 kg	41 lbm	0.84 kg	1.85 lbm
Column	506 kN	114 kipf	0.052 m ³	1.84 ft ³	38.6 kg	85 lbm	0.0047 m ³	0.166 ft ³	36.6 kg	81 lbm	0.77 kg	1.70 lbm
Beam	84.02 kN·m	61,970 lbf·ft	0.064 m ³	2.26 ft ³	48.2 kg	106 lbm	0.0116 m ³	0.410 ft ³	91.3 kg	201 lbm	1.24 kg	2.73 lbm

Table 5: Costs of bamboo-steel structural members.

	Bamboo (\$)	Steel (\$)	Adhesive (\$)	Total (\$)
Slab	43.95	10.58	4.64	59.17
Wall	38.21	14.57	5.49	58.27
Column	25.16	28.58	5.03	58.77
Beam	31.41	71.37	8.07	110.85

CONCLUSION

The fabrications and mechanical behaviours of bamboo-steel composite structural members were summarized in this paper. The composite structures are composed of bamboo plywood and cold-formed thin-walled steel channels bonded by structural adhesive and strengthened by screws. Researchers have already shown bamboo has great potential to be used as a sustainable structural material, especially the laminated bamboo lumber and bamboo plywood. The bamboo-steel composite structures discussed in this paper are light weight and easy to fabricate. They take advantage of sections with large moment of inertia and radius of gyration formed by the thin-walled steel sheet, and the stability created by bamboo plywood. The lab testing for composite slab, wall, column, and beam indicated the two materials performed excellent composite effect under proper bonding created by structural adhesive and screws. The transformed-section method was proposed to determine the load bearing capacities of various composite structural members. The theoretical models were used to design the structural members of a two story building. The costs of materials show the composite structural system has economic advantage but the benefit needs to be determined by a life cycle analysis.

However, some issues have not been addressed by the existing studies. Bonding at the interface between bamboo plywood and steel sheet plays an important role in influencing the performance of the composite structures. The authors of this manuscript are investigating the bonding stress and slippage at the interface of the two materials under short term and long term static loads. The behaviour of the interface under the dynamic or reversal loads needs to be evaluated. As the un-braced length of the composite beam increases, lateral torsional buckling of the beam occurs. The simplified model does not consider the influence of un-braced length on the ultimate bending capacity of the beam. The durability of the composite structural members needs to be investigated especially under the extreme environmental conditions. In addition, as discussed in Section 3, a life cycle analysis model for the bamboo-steel composite structure needs to be established to evaluate and compare the sustainability of the composite structures with other conventional structures. These issues will be addressed in the future research studies.

ACKNOWLEDGEMENTS

This study was funded by National Natural Science Foundation of China under Grant No. 51378265. The authors would like to acknowledge many graduate students at Ningbo University, China who have participated in the research studies on bamboo-steel composite structures.

REFERENCES

- American Wood Council. 2005. *National design specification (supplement) - design values for wood construction*. American Forest & Paper Association, Inc.
- Brundtland, G.H. 1987. *Report of the world commission on environment and development: our common future*. Accessed on 9/13/2012 from <http://www.un-documents.net/our-common-future.pdf>
- Janssen, J.J.A. 2000. *Designing and building with bamboo*. Beijing, China: INBAR. Accessed on 10/10/2014 from www.inbar.int/downloads/inbar_technical_report_no20.pdf?7c424b
- Lee, A.W.C., Bai, X., Peralta, P.N. 1994. Selected physical properties of giant timber bamboo grown in South Carolina. *Forest Prod J.* 40–6.
- Liese, W. 1987. Research on bamboo. *Wood Science Technology* 189–209
- Li, Y., Shan, W., Huang, Z., Ge, Be. and Wu, Y. 2008. Experimental study on mechanical behavior of profiled steel sheet-bamboo plywood composite slabs. *Journal of Building Structures.* 29 (1), 96-102.
- Li, Y., Shen, H., Zhang, W., and Han, T. 2010. Experimental study on a seismic behavior of profiled steel sheet-bamboo plywood composite walls. *Engineering Mechanics.* 27 Sup. I, 108-112.
- Li, Y., Shen, H., Shan, W., Lv, B., and Jiang, T. 2011. Experimental study on shear behavior of I-shape section bamboo-steel composite beams. *Journal of Building Structures.* 32(7), 80-86.
- Li, Y., Guo, J., Jiang, T., and Xu, J. 2013. Experimental study on seismic behavior of cold-formed thin-walled C steel-bamboo plywood composite walls. *Journal of Shenyang Jianzhu University (Natural Science).* 29 (6), 969-976.
- Mahdavi, M., Clouston, P.L., Arwade, S.R. 2011. Development of laminated bamboo lumber: review of processing, performance, and economical considerations. *Journal of Materials in Civil Engineering* 23(7), 1036-1042.
- Mahdavi, M., Clouston, P.L., Arwade, S.R. 2012. A low-technology approach toward fabrication of laminated bamboo lumber. *Construction and Building Materials.* 29, 257-262.
- van der Lugt, P., van den Dobbelsteen, A.A.J.F., and Janssen, J.J.A. 2006. An environmental, economic and practical assessment of bamboo as a building material for supporting structures. *Construction and Building Materials.* 20, 648-656.
- Xie, Q., Zhang, W., Jiang, T., Xu, J., Yan, Z., and Li, Y. 2012. Experimental study on performance of steel-bamboo composite column under axial compression. *Engineering Mechanics.* 29 Sup. II, 221-225.
- Xu, J. 2012. *Experimental study on seismic resistance and thermal behavior of cold-formed thin-walled Steel - bamboo plywood composite walls*. M.S. thesis, Ningbo University, China.
- Zhang, Z., Li, Y., and Liu, R. 2015. An analytical model of stresses in adhesive bonded interface between steel and bamboo plywood. *International Journal of Solids and Structures.* 52, 103-113.

Bi-directional thermo-hygroscopic facades: Feasibility for liquid desiccant thermal walls to provide cooling in a small-office building

Marionyt Tyrone Marshall¹

¹Perkins+Will, Atlanta, Georgia

ABSTRACT: The paper will discuss the design of a bi-directional thermo-hygroscopic façade as a dedicated outdoor air system to cool and dehumidify outside air. The system is a variant of dedicated outdoor air systems to separate dehumidification and cooling in air-conditioning equipment and locates components within the building envelope. The integrated hybrid-building envelope relies on low-grade thermal energy to regenerate the liquid desiccant from southerly and northerly exposure. Southern and northern exposed walls with solution desiccant regenerator, dehumidifiers and direct evaporative cooler provide similar function as a conventional vapor compression air-conditioning system. Liquid desiccant regenerates with temperatures as low as 50°C (122°F). The consolidation of components for air-conditioning within the building envelope offers architectural expression and system adjacency to a source of fresh air. The use of the direct evaporative cooler makes use of cool dry dehumidified air to cool chilled water for use in radiant ceiling panels instead of conventional air conditioning equipment and refrigerant to minimize the impact to the environment. Regenerative liquid desiccant thermal walls use low-grade source of heat to reduce system energy consumption and reliance on sources of refrigerant to provide cooling and dehumidification.

KEYWORDS: Thermal-Hygroscopic; Façade; Bi-Directional; Liquid Desiccant; Regenerative

1.0. INTRODUCTION

The proposition for decoupling air-conditioning systems from dehumidification and cooling is not a new idea. The systems can undergo rapid configuration and experimentation. Dedicated outdoor systems provide decoupling of cooling from dehumidification. These kinds of systems operate differently but offer little opportunity for architectural integration or expression. The systems are often located 'out of sight' from occupants. The movement of air conditioning equipment from the building roof or mechanical space to the building envelope is uncertain and risky. It requires consideration for different solutions in the earliest points of building design, energy modeling and simulation. The speculative feasibility is not without issues of risky structural, thermal, cost, and energy issues.

1.1. Indoor air quality, ozone, depletion and global warming potential

Rising demand and adoption rate for air conditioning is commonplace all over the world. With conventional approaches to air-conditioning, poor air quality can make the indoor environment harmful to occupants (Yu, et al. 2009). Conventional air conditioning systems maintain comfortable indoor environments. These systems maintain comfortable interior environments. These systems minimize the growth of microbial fungus, mildew with musty odors in HVAC condensate-pan and moist air in ductwork (Gandhidasan and Mohandes 2011). Typical air loading to conditioned spaces is about 0.0005-0.0094 m³/s (15-20 ft³/minute) per-person mixture with fresh air (Gandhidasan and Mohandes 2011). Outside air has much more moisture content than the heat load within a space (Gandhidasan and Mohandes 2011). Conventional air-conditioning equipment efficiently removes sensible loads with thin coils and high supply air velocities (Gandhidasan and Mohandes 2011). The equipment cools air temperatures below 7°C and consumes energy to improve latent thermal energy removal efficiency (Gandhidasan and Mohandes 2011).

Commercial office building data shows a relationship between floor area, number of buildings and primary energy consumption (U.S. Department of Energy (DOE) 2012). The data shows that office buildings account for the largest aggregation of floor area, number of buildings, and energy consumption. Most of the other types have lower primary energy consumption when compared with commercial office space. The building type is characterized with 10% and 17% higher trend than other types.

1.2. Building water and energy consumption

Conventional air-conditioning systems cool air below the dew-point temperature to condense the moisture vapor out of the air and remove latent thermal energy (Yu, et al. 2009). Although not always the case, these systems can consume more electric energy in a second pass to reheat the same air stream after cooling

such that the air temperature reaches a point that is a comfortable for occupants before delivery to the intended spaced for conditioning (Yu, et al. 2009). The chilled water system uses more electrical energy to cool water to a temperature lower than fresh air. This allows for larger temperature differences between the cooling water and fresh air to improve system cooling efficiency. Latent heat and sensible heat removal take place in a single heat exchanger system at the same time (Yu, et al. 2009). The system must run longer to reach a lower chilled water temperature (Dieckmann, Roth and Brodrick 2008). It must also operate in an overcooling state. The conventional air-conditioning system operates with three to four Energy-Efficiency Rating (EER), which implies that the Coefficient of Performance (COP) is less than or slightly more than one. Systems with EER of this magnitude must remove heat to provide necessary cooling but at the expense of higher electrical energy consumption per hour.

1.3. Adaptive thermo-hygroscopic building envelope

The building envelope can connect and directly dehumidify fresh air and drive energy expenditure to its lowest level. The components that describe the separation of latent load removal and sensible heat removal within the building envelope are theoretical, experimental, and risky. Liquid solutions can scavenge water vapor from air, including pollutants and separately lower air temperature. These systems have similar strategies the design of conventional systems in that they operate at a distance from the building envelope. An adaptive thermo-hygroscopic building envelope relocates these components to the building envelope at the nearest point of contact with fresh air. A 93 m² (1,000 ft²) commercial office-building prototype provides a test platform to decouple dehumidification and an alternative smaller sized-system size for cooling. The system is biologically inspired and makes use of a benign liquid desiccant salt solution.

2.0. ORIGINS

Early systems research provides data to understand the common traits for the use of hygroscopic materials to absorb and condense the moisture vapor from ambient air. The water absorbing and insulation materials are instrumental in the functioning of certain devices. These common convergences may transfer to a building envelope based liquid desiccant system with absorbent and insulating surfaces.

2.1. Dewponds 10,000 B.C. to 2,000 B.C.

Neolithic humans develop larger dewponds nearer the end of the period around 2000 BC. The basic construction of the dewpond is a round artificial depression in the ground with a neighboring embankment. The dry clay soil performs as the hygroscopic material. The dewponds may have provided over a thousand sheep with daily water requirements from one single dewpond (Hubbard and Hubbard 1916). Dewponds use a dynamic hygroscopic process cycle and fill with water each morning day.

2.1.1. Dewpond construction

Modern construction of ancient dewponds uses a process that excavates out the earth with a larger radius than required for the final pond (Hubbard and Hubbard 1916). An insulating coating of dry straw covers the hollow depression (Hubbard and Hubbard 1916). A layer of puddled clay covers over the straw. Next, a layer of stones covers the puddled clay (Hubbard and Hubbard 1916). The observation of the earth works shows that the ponds fill with water in the absence of rainfall, and larger depression ponds fill more rapidly.

2.1.2. Dewpond constraints

Dewpond thermodynamic performance is highly dependent upon the stable dry straw insulation layer. The insulation layer must not become moist or wet as this lowers the insulation resistance between the puddled clay and subsurface ground. Conduction of heat from the subsurface ground to the puddled clay will interrupt the performance of the condenser surface. Dewponds work because of their insulation layer construction.

2.2. Air wells

In the early 20th century, F.I. Zibold reinvents the dew condenser based on the work of ancient Greeks in Theodosia, a city on the Crimean peninsula in Ukraine near to 700 B.C. Dew condensers condenses water from moisture laden fresh air. The dew condenser features a cone and funneled shape structure made from stacked sea-beach pebbles (Nikolayev, et al. 1996). The cone and funnel mound sits atop a concrete base in the shape of a bowl (Nikolayev, et al. 1996). Zibold's dew condenser did not work.

2.2.1. Air well thermodynamics

In 1996, the researchers Nikolayev et al investigated Zibold's original manuscripts, documents, and earth-work remains to understand the cause for the failure of the dew condenser (Nikolayev, et al. 1996). The operation of the dew condenser relies on the different in temperature between a surface receiving solar

radiation and the ground. After the sun has set, the surface radiates heat to the immense cold night sky. The once warm surface cools from heat loss to the night sky. The rate of cooling from the surface lowers significantly when it connects thermally to the ground. Thermal isolation with the ground improves cooling capacity between the radiating surface and the night sky. In this situation, the surface will radiate more heat to the night sky surface with a smaller amount to convective heat air currents. Ground decoupling and thin double-sided surface geometry can improve the performance of the air wells. Air wells tend to work better with low thermal lag construction.

3.0. PAST RESEARCH

Biological analogues offer useful models of inspired design for their adaptation and deployment of low-energy and resource economy (Pawlyn 2011). Biologically inspired design can learn from analogues and their unique methods of innovative adaptations for airflow movement in nature. Biological adaptations resemble the human technological design in function, but differ in energy expenditure. Air-conditioning systems rely on high-energy intensive functions that require high-grade energy to provide indoor air comfort. Biological analogues offer strategies that use low-grade energy expenditures for airflow regulation, temperature, and humidity control.

3.1. Biological inspired design as performance adaptation

Biological analogues for airflow control, temperature and humidity control make use of their immediate environment to create an associative, connective, and functional physical habitat. The leaf-cutting ant harnesses the wind through adaptations to nest architecture. The Great Plains prairie dog harnesses the wind through its tunnel architecture. The architectural characteristics of leaf cutting ant nest and prairie dog tunnel may offer adaptations for passive airflow control of temperature, humidity, and ventilation.

3.1.1. Leaf cutting ant harnesses wind

The leaf cutting ant nest works similarly to a building envelope in that it provides protection from predators and climatic conditions. The nest structure allows for a dynamic relationship between inflow of air, gases and an outflow of air (Bollazzi, Forti and Roces 2012). The nest adaptation for passive nest ventilation uses wind-induced airflow (Kleineidam, Ernst and Roces 2001). Deployment of key components of the nest hierarchical structure allows a highly inter-connective strategy to achieve multiple low energy functions and resource economy.

3.1.1.2. Leaf-cutting ant nest performance

The nest habitation relies on the manipulation of nest openings and subtle gas exchange in the upper and lower areas. The interconnected dependency on interactions to direct the flow of air and tune torrent definition offers transferable characteristics of wind-induced apertures such as an articulated ventilation flap for buildings.

3.1.2. Great Plains prairie dog harnesses wind

The Great Plains prairie dog burrows harness wind energy through the development of changes in laminar flow along the ground surface. The adaptations allow the small animal to survive in extended below grade tunnels for long periods with adequate air mass exchange.

3.1.2.1. Great Plains prairie dog burrow performance

Similarly, to the leaf-cutting ant, the prairie dog orients its inlet and outlet mound to a direction parallel to the wind flow with articulation characteristics. The offset inlet and outlet mound openings have similarities to offset ventilation. The small number of openings resembles strategies for minimizing openings in buildings.

4.0. SYSTEMS

The north and south facade features a theoretical reversible solar liquid desiccant air conditioning with dedicated outdoor air system to provide decoupling of air conditioning from dehumidification. Each floor level is equipped with its own independent system. Each facade can provide dehumidification of fresh air while the opposite facade provides dehumidification or humidification of operational process air.

Hygroscopic building envelopes like the one proposed for the south and north facades have limited dry duct systems. The system affords less vapor moisture air and dust-free environment to prevent dust collection and fungus, mold and bacterial growth, which can lower indoor air quality. High levels of vapor moisture introduction increase operational maintenance to remediate mold, mildew, corrosion, and replacement of wall and window coverings and carpet. Outdoor air systems like the liquid desiccant system remove latent heat energy and improve dehumidification management when compared with other mechanical ventilation systems (Dieckmann, Roth and Brodrick 2008). They remove moisture without cooling air supply

temperatures to the point of condensation. Relative humidity levels below 70 percent keeps surfaces dry and free of mold and bacterial growth (Dieckmann, Roth and Brodrick 2008). The hygroscopic solution in these systems scavenges airborne contaminants and increases fresh air volumes (Dieckmann, Roth and Brodrick 2008) (Yu, et al. 2009).

4.1. Direct-expansion vapor compression refrigeration air conditioning system

Figure 1 shows the layout and components of the direct-expansion vapor compression system. The system moves refrigerant around a closed loop. It removes heat from fresh air and feeds cool air into a space. Figure 1 and 2 describe the thermodynamic state of the refrigerant as it cools and dehumidifies the warm outside air. Numbers in 'RED' color show the relationship between state conditions in the diagram. Outside air at state '0' mixes with return air at state '4'. The mixed air stream enters the evaporator coil at state '5'. The supply air is in direct contact with the evaporator cooling coils. The cool and dry air stream leaves the evaporator at 13°C (55 °F) and 50% relative humidity at state '1'. The mechanical system warms and slightly humidifies the air temperature to 23°C (74°F) with near constant relative humidity while coinciding with state '2' or the conditioned space. The supply air and recirculation air mix, heats up and humidifies in the conditioned space as represented by the line segment from state '2' to states '3' and '4' in Figure 2. A fan draws air from the space or state '3' to state '4'. The process repeats with outside air at state '0' entering the mixing box. The system here provides a simpler case for heat transfer by refrigerant from fresh air than more complex systems where air flows over an intermediate fluid; the fluid or chilled water then flows over the evaporator coils of a chiller.

4.2. Thermo-hygroscopic solar liquid desiccant air conditioning system

In the Figure 3 plans, sketches show different arrangements of length and width for stair and elevator core. A dashed line represents the location for the thermo-hygroscopic building envelope. Figure 4 shows the section sketches of the plan configurations and liquid desiccant solar regenerator. The 'X = Y' plan configuration refers to length and width dimensions for external core on either the west or east side offers improvement to day-lighting. Solar liquid desiccant regenerators use incline path to direct flow downward by gravity to desiccant dehumidifier. The regenerator panel requires an appropriate tilt angle and orientation with the least amount of shading from site elements that are self-shaded by building. Figure 4 shows dual sided options for thermo-hygroscopic envelope facing north and south. North-facing envelopes do not line up with solar access. A different configuration moves the liquid desiccant regenerator further away from dehumidifier components to overcome building self-shading on the north facade.

The thermo-hygroscopic building envelope decouples thermal energy removal through an air ventilation system and waterside cooling and heating system. The system uses hydronic cooling, radiant ceiling panels for sensible energy loads, and solar liquid desiccant air-conditioning system for latent energy loads. The ceiling panels use chilled water to transfer heat by radiation and convection. The work is related to a system proposed by Yin et al for their liquid desiccant dehumidification radiant cooling system (Yin, Zhang and Chen 2007) (Yin, Zhang and Chen 2008). Their system uses similar components, including solar regenerator, dehumidifier, direct evaporative cooler, and ventilation units. The system in the paper integrates an additional dehumidifier and configuration of these components within the building envelope. Figure 5 shows the system re-imagined within the building envelope.

Radiant ceiling panels circulate chilled water through small tubing to remove sensible heat energy. To prevent condensation issues chilled water must be above ambient dew point usually between 13°C and 16°C (55°F and 60°F). The higher chilled water and room temperature reduces temperature differential to

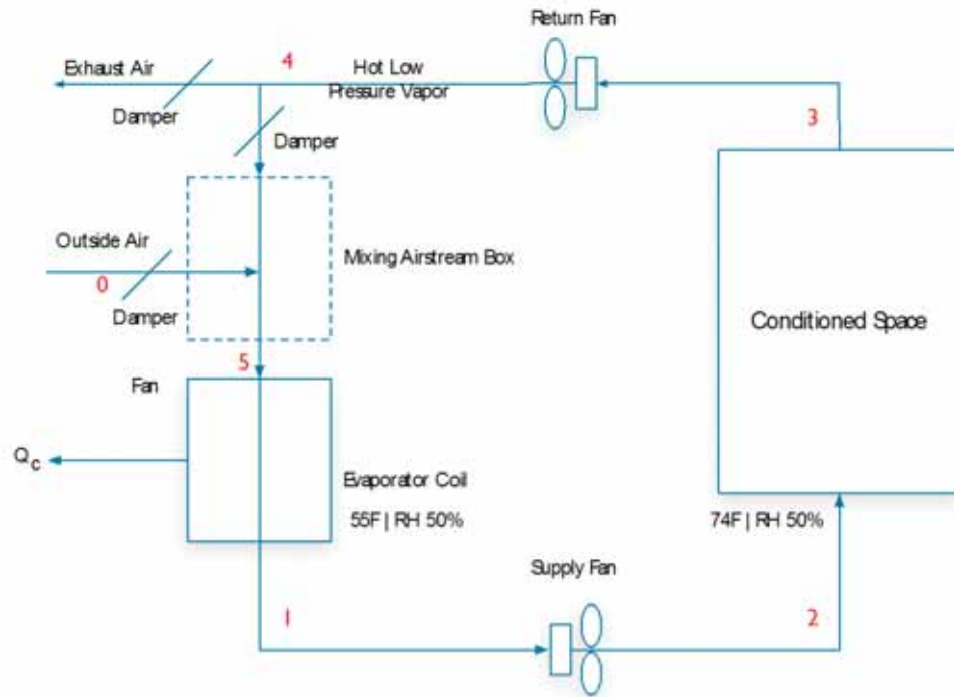

Figure 1: Building air conditioning process sketch, derived from (Kreider 1994).

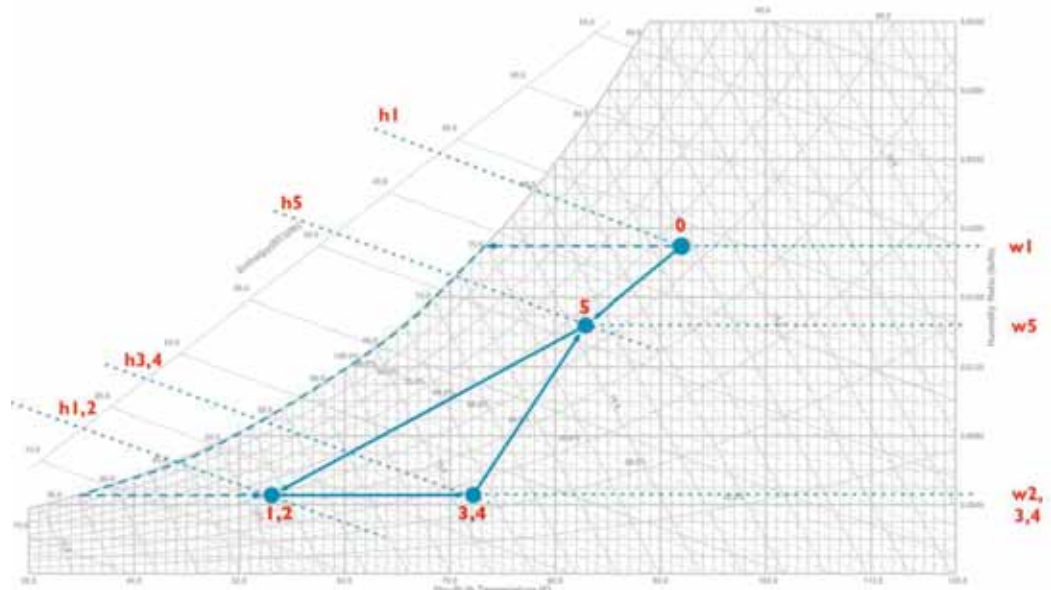

Figure 2: Direct expansion vapor compression refrigeration process psychrometric chart.

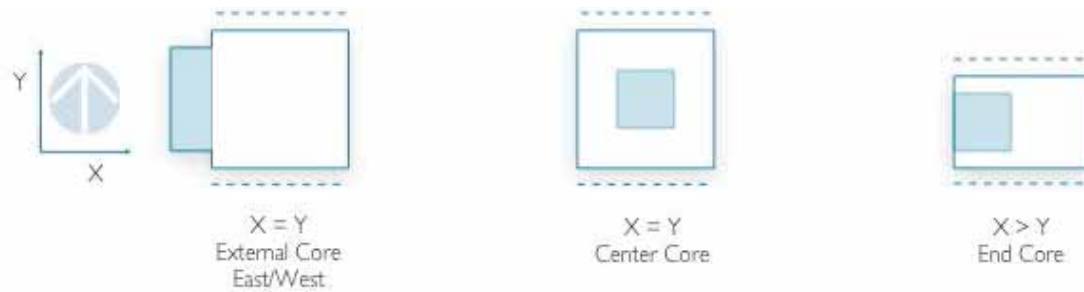

Figure 3: Plan sketch of north and south thermal-hygroscopic envelope design.

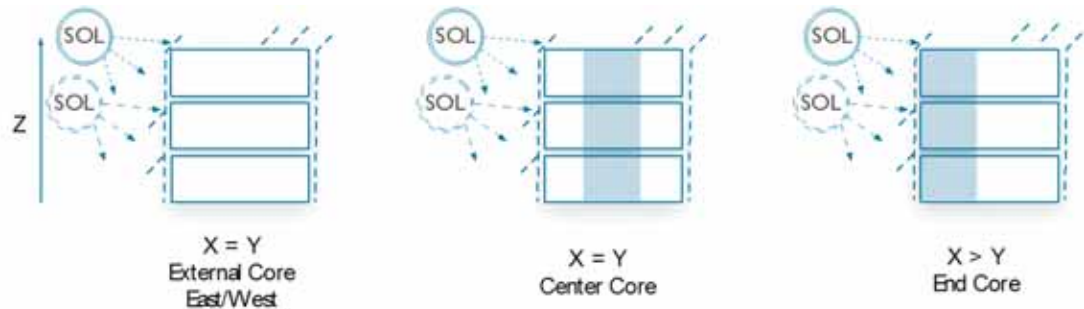

Figure 4: Section sketch of north and south thermal-hygroscopic envelope design.

-7°C and -10° C (19°F and 14 °F). Radiant ceiling panels take dehumidified air from the liquid desiccant system through separate diffuser from ceiling-mounted units for further cooling. The design requires less than one air changes per hour, which is within the capacity of the ceiling system. Higher chilled water operating temperature reduces pump size and parasitic energy.

The spatial configuration purposely incorporates a small single thermal zone with ductless air volume. Bio-inspired articulated torrent flaps on the building envelope control the airflow rate by opening and closing. The flaps' articulation is an inspired concept from the leaf cutting ants nest openings and prairie dogs burrow mounds. Outside air flows through articulated flaps into the liquid desiccant dehumidifier. The desiccant flows from top to bottom of the dehumidifier opposite to the air moving from bottom to top. The thermodynamic state of air drives the ventilation rate with supplemental fans. Air temperature varies throughout the system to remove sensible heat energy.

The hygroscopic building envelope is an integrated building solar liquid desiccant air-conditioning system that removes latent heat energy. The system delivers dry conditioned air to the compact office space. The separation of fresh air dehumidification and recirculation air is done to limit issues with air infiltration from crossing air streams and condensation issues through the building envelope. The system uses dry air to reduce the amount of supply air volume needed for ventilation from a lower humidity ratio when compared with an all-air single-stage vapor compression refrigeration (Yin, Zhang and Chen 2008). Fan and flaps control the amount of air volume based on latent thermal loads. Less air volume and movement of dry air reduce fan size and parasitic energy losses. A gas heater regenerates the liquid desiccant in the regenerator for conditions when there is no solar radiation available.

The two systems do not remove sensible or latent energy loads primarily through convection. Lower air volumes from radiant ceilings and dehumidification system minimize air velocities to minimize drafts. Comparison of latent and sensible load for drying air in a single-stage vapor compression and solar liquid desiccant system is possible. Figure 5 shows a sketch of the psychrometric chart of the process for dehumidifying outside air for the system. An inlet at the facade draws in the outdoor air at state '0'. Outdoor air temperature is 34°C (94°F). The fresh air indirectly cools by the weak liquid desiccant from state '0' to '1'. Fresh air at state '1' enters a mixing box. The air then mixes with return air from direct evaporator at state '2' and cools. The supply air enters the liquid desiccant dehumidifier and leaves with lower enthalpy. The dehumidifier heats and dries the air from state '2' to '3' with constant enthalpy. The hot dry air leaving the dehumidifier cools with chiller water from state '3' to '4'. The dry air-cools again indirectly from the air leaving the direct evaporative cooler at state '2'. Another dehumidifier heats and dries the return air from state '5'.

The dry air leaving the second dehumidifier cools to state '6'. A portion of the air enters the conditioned space leaving state '6' while another stream of air enters the direct evaporator. The cool and dry air passes over water coils. The temperature of the water in the cooling coil lowers. This water continues on a path to the radiant ceiling panels to cool the interior space. The warmer air leaves the direct evaporator at state '2' to mix with air at state '1'. The process repeats with fresh air drawn into articulated flaps by differential air pressure to the mixing box at state '1'. Table 1-5 and Figure 7 show the total heat removal calculation in the summer.

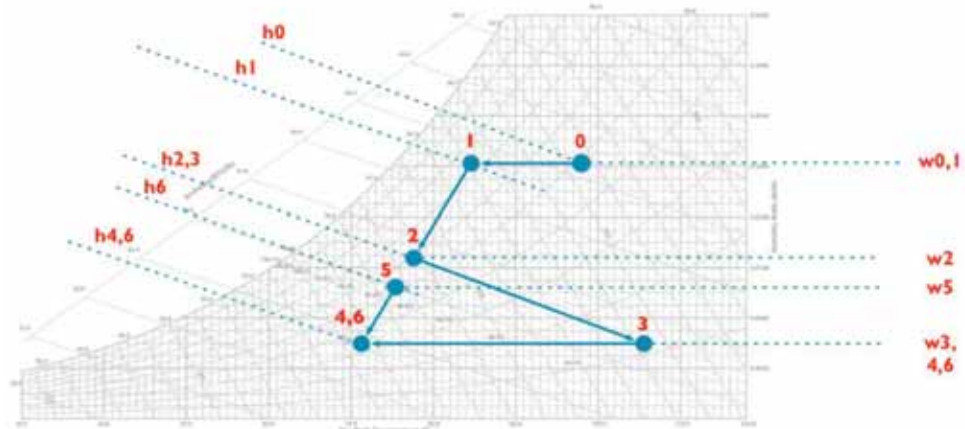

Figure 5: Air conditioning dehumidification process in the psychrometric chart for thesis liquid desiccant.

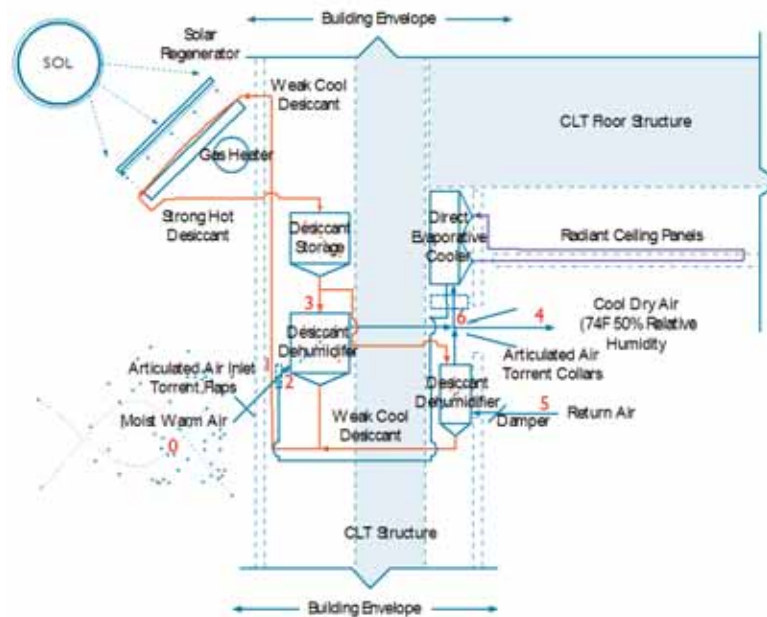

Figure 6: A detail sketch that shows solar liquid desiccant air conditioning building envelope system.

Assumptions for occupant load, ventilation requirement per person allows for calculation of a number of model data points. The heat transmission and solar gain from internal loads allow for computation of sensible and latent loads. Temperature states for outdoor air, conditioning of supply air, and office space air allow for plot on a psychrometric chart. The amount of supply ventilation, room ventilation is calculated. The total heat load allows for sizing of equipment to cool the space.

Table 1: Thermo-hygroscopic model data and conditions for summer heat load.

Design model data	Value	Units
Floor area	94(1,015)	m ² (ft ²)
Floor area per person	5(50)	m ² (ft ²)
Number of occupants	20.30	Persons
Ventilation per occupant	0.5(17)	m ³ /person(ft ³ /person)
Supply air temperature	13(55)	°C(°F)
Room dry bulb temperature	23(74)	°C(°F)
Room relative humidity	50	%
Outdoor temperature	34(94)	°C(°F)
Delta T	-7(19)	°C(°F)
Window area	30(318)	m ² (ft ²)
Wall area	143(1536)	m ² (ft ²)
Roof area	95(1024)	m ² (ft ²)

Table 2: Heat and solar gain transmission from people, lights, equipment, walls, windows and roof.

Space gains	Value	Units
Sensible load, (Grondzik, et al. 2006)	73(250)	W(Btu/h)
Latent load, (Grondzik, et al. 2006)	59(200)	W(Btu/h)
Sensible load for office equipment, (Grondzik, et al. 2006)	2.5(0.80)	W/m ² (Btu/hr-ft ²)
Sensible load lights, (Grondzik, et al. 2006)	6.3(2)	W/m ² (Btu/hr-ft ²)
Window gains, (Grondzik, et al. 2006)	66(21)	W/m ² (Btu/hr-ft ²)
Wall gains, (Grondzik, et al. 2006)	79(25)	W/m ² (Btu/hr-ft ²)
Roof gains, (Grondzik, et al. 2006)	142(45)	W/m ² (Btu/hr-ft ²)

Table 3: Calculation of the amount of cooling needed for prototype model.

Load Calculation	Load	Units
Sensible = sensible heat * number of occupants	1,487(5,074)	W(Btu/h)
Sensible = lights * floor area	1,190(4,059)	W(Btu/h)
Sensible = equipment * floor area	595(2,029)	W(Btu/h)
Sensible = heat gain window(window/floor area) * window gain	238(812)	W(Btu/h)
Sensible = heat gain walls (walls/floor area) * wall gain	2.1(7)	W(Btu/h)
Sensible = heat gain roof (roof/floor area) * roof gain	11(38)	W(Btu/h)
Latent = latent load * number of occupants	13.2(45)	W(Btu/h)
Sensible total = total summer people and internal gains (sensible heat)	2,346(8,005)	W(Btu/h)
Latent total = total summer people and internal gains (latent heat)	-7(19)	m ³ /min(ft ³ /min)
Calculation = portion of sensible load heat factor (RSH/RSH+RSH)	0.66	
Calculation = quantity of air (RSH/1.1 delta T) needed to cool	30(381)	m ³ /min(ft ³ /min)
Calculation = supply air volume (occupants * cfm per person)	143(345)	W(Btu/h)
Calculation = outdoor portion of supply air (needed air/supply air volume)	91	%

Table 4: Heating load on cooling equipment, tons of cooling required calculation.

Total heat to be removed by cooling equipment	Value	Units
Psychrometric chart, point h ₂	94(20.4)	kJ/kg (Btu/lb)
Psychrometric chart, point h ₃	5(41.7)	kJ/kg(Btu/lb)
Calculation Q _t = 4.5 * cfm*(h ₃ -h ₂)	(33,072)	W(Btu/h)
Cooling required	2,509(2.76)	kg(ton)

Table 5: Psychrometric data for plot of Table 1, 2, 3 and 4.

Point	Description
0	Room Dry Bulb Temperature
1	Supply Air Temperature
2	Outdoor Temperature
3	Calculated From Outdoor Portion Supply Air and Psychrometric Chart

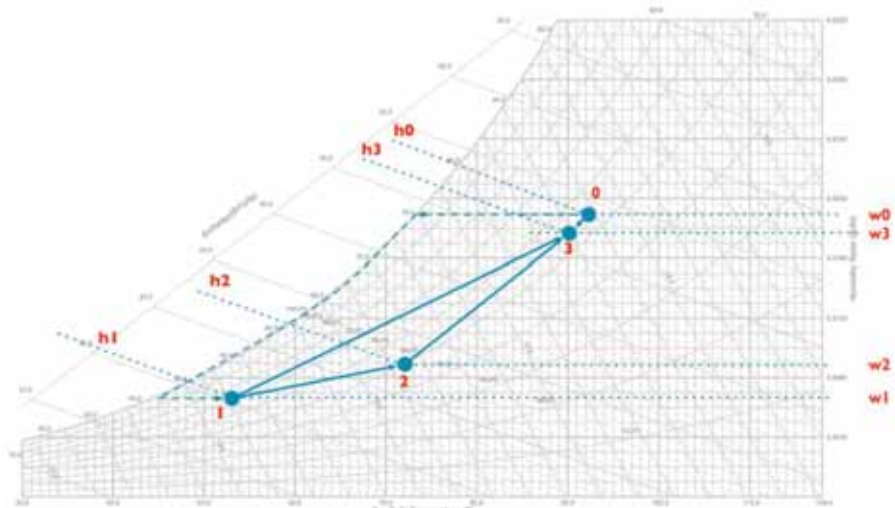

Figure 7: Psychrometric plot of Table 1, 2, 3, and 4.

5.0. SYNTHESIS

The process has led to discovering mechanisms in the historical and biological references that delineate obvious improvements to those that differ too greatly for potential application transfer. The tables show a range of divergences, and convergence triggers between conventional air-conditioning systems and thermo-hygroscopic envelope to dewponds, air wells, prairie dog burrow and leaf-cutting ant nest.

5.1. Historical Implications

The historical implications for the paper provide a working platform to improve the speculative thermo-hygroscopic building envelope. Table 6-7 shows comparable performance criteria between the thermo-hygroscopic 'thick wall' and the earlier discussion of dewponds and air wells in section 1.1. The list shows characteristics that are the same, similar, and different. The differences provide an opportunity for making a change in an existing system to improve it in some way.

Table 6: Bio-inspired comparison of the thermo-hygroscopic envelope to dewponds.

<i>Performance criteria</i>	Thermo-hygroscopic envelope	Comparison	Dewponds
<i>Condensing mechanism</i>	Contact with ambient air	Same	Contact with ambient air
<i>Regenerative mechanism</i>	Heating	Same	Drying
<i>Condensing constraint</i>	Short time	Different	Long time
<i>Condensing Surface Area</i>	Large thin falling film	Same	Large thin surface area
<i>Regenerative shape</i>	Angle of incline	Different	Depression
<i>Regeneration orientation</i>	Vertical	Different	Horizontal
<i>Condensing material</i>	Liquid desiccant	Different	Solid desiccant
<i>Water desorption</i>	Differential vapor pressure	Different	Decoupled from ground
<i>Water generation</i>	Surface vapor pressure	Different	Stable insulation layer

Table 7: Bio-inspired comparison of the thermo-hygroscopic envelope to air wells.

<i>Performance criteria</i>	Thermo-hygroscopic envelope	Comparison	Air wells
<i>Condensing mechanism</i>	Contact with ambient air	Same	Contact with ambient air
<i>Regenerative mechanism</i>	Heating	Same	Drying
<i>Condensing constraint</i>	Short time	Different	Long time
<i>Condensing Surface Area</i>	Large thin falling film	Same	Large thin surface area

<i>Regenerative shape</i>	Angle of incline	Different	Depression
<i>Regeneration orientation</i>	Vertical	Different	Horizontal
<i>Condensing material</i>	Liquid desiccant	Different	Porous desiccant
<i>Water desorption</i>	Differential vapor pressure	Different	Decoupled from ground
<i>Water generation</i>	Surface vapor pressure	Different	Low thermal lag response

5.2. Biological Implications

Table 8-9 shows criteria for selective performance and functional mechanisms to improve conventional air-conditioning systems. Orientation of nest and burrow openings to the wind is a successful adaptation. The articulation of vents flaps offer improvements to intake and exhaust performance. The biological analogue comparison can offer benefits to conventional and speculative air-conditioning systems. The system may also use biologically inspired articulated flaps to control aperture sizes of air inlet areas. The flaps use an energy management system where it can respond to relative humidity levels within the interior office space. The control of air admittance, shaping of flap apertures, and height displacement follow the bio-inspiration from the prairie dog and leaf cutting ant. Vertical height displacement of sets of flaps admits air into the absorber sections of hygroscopic building envelope and allows air to mix with indoor air as dehumidified process air. The data from this process delivers rich untapped resource for further work to improve the design and integration of the thermo-hygroscopic building envelope.

Table 8: Bio-inspired comparison of conventional air-conditioning equipment systems to leaf-cutting ant nest.

<i>Performance criteria</i>	Air conditioning systems	Comparison	Leaf-cutting ant nest
<i>Seasonal adaptation</i>	Fixed	Different	Orient to wind direction
<i>Adaptation mechanism</i>	Variable air volume	Similar	Open/close nest openings
<i>Structure</i>	Parallel connecting ductwork	Similar	Parallel connecting tunnels
<i>Humidity control</i>	Evaporative condenser	Different	Nest cultivation of fungus
<i>Thermal convection</i>	Forced convection	Different	Convective/diffusive
<i>Airflow movement</i>	Forced convection	Different	Convective diffusive
<i>Airflow mechanism</i>	Offset inlet and outlet	Same	Offset inlet and outlet
<i>Airflow performance</i>	Pressure drop	Similar	Pressure drop
<i>Airflow penetrations</i>	Small number	Different	Large number
<i>Airflow adaptation</i>	Vents	Different	Torrent articulation
<i>Directional adaptation</i>	No specific adaptation	Different	Openings orient to face wind
<i>Exergy adaptation</i>	No specific adaptation	Different	Wind harvesting

Table 9: Bio-inspired comparison of conventional air-conditioning equipment systems to prairie dog burrow.

<i>Performance criteria</i>	Air conditioning systems	Comparison	Leaf-cutting ant nest
<i>Seasonal adaptation</i>	Fixed	Different	Orient to wind direction
<i>Adaptation mechanism</i>	Variable air volume	Similar	No specific adaptation
<i>Structure</i>	Parallel connecting ductwork	Similar	Parallel connecting tunnels
<i>Humidity control</i>	Evaporative condenser	Different	Side passages balance
<i>Thermal convection</i>	Forced convection	Different	Induced wind airflow
<i>Airflow movement</i>	Forced convection	Different	Induced wind airflow
<i>Airflow mechanism</i>	Offset inlet and outlet	Same	Offset inlet and outlet
<i>Airflow performance</i>	Pressure drop	Similar	Pressure drop
<i>Airflow penetrations</i>	Small number	Different	Small number
<i>Airflow adaptation</i>	Vents	Different	Torrent articulation
<i>Directional adaptation</i>	No specific adaptation	Different	Openings orient to face wind
<i>Exergy adaptation</i>	No specific adaptation	Different	Wind harvesting

5.3. Energy reductions, consumption, and cost implications

Yu et al decoupled liquid desiccant system consists of a single regenerator and desiccant storage tank serving individual building-level desiccant dehumidifiers (Yu, et al. 2009). The performance of their system shows energy, consumption, and cost reductions for summer and winter. With latent loads between 10% and 50%, the system energy consumption and operational costs are 80% and 75% of conventional air-conditioning systems (Yu, et al. 2009). The reductions and savings can be much less in their model with solar energy to regenerate the liquid desiccant and ground water for radiant ceiling panel system. The cost associated with uncertainty with the high integration of these components within the building envelope requires further investigation.

Adoption of liquid desiccant systems remains an issue for commercial buildings due to their higher-energy costs, first costs, and moisture carryover. Corrosion of metal components leads to more expensive components and design modifications in equipment in these systems. Further development to test liquid concentrations with sodium chloride and calcium chloride improves the consideration for solutions with less corrosion and toxicity issues. Use of low-cost waste heat and solar-energy offer benefits to driving cost of these systems lower. Research on micro-porous membranes that allow water to migrate to air but impervious to desiccant in desiccant dehumidifiers avoids the carryover and corrosion issues (Dieckmann, Roth and Brodrick 2008). Special surfaces that form thin desiccant film flows offer improvements in minimizing carryover and corrosion issues (Dieckmann, Roth and Brodrick 2008). Thinner film flows of liquid desiccant can offer improvements to the solar regenerator with more surface area contact with the absorber surface.

CONCLUSION

The paper discusses the environmental, historical, bio-inspired design, past systems, and materials and components for a hygroscopic building envelope to function. The feasibility of the system limits itself to thermodynamic understanding of liquid desiccant performance and fresh air in this system. The mechanism transfer from beneficial performance criteria in the historical and biological examples provides an array of improvements to the system. Integration of the primary components at a schematic level provides enhanced understanding of the difficulties of the proposition. Bio-inspired design requires future work to advance and incorporate improvements in thermal components for thermo-hygroscopic envelope assembly. Bidirectional solar liquid desiccant units on the north and south elevation offer higher level of system functioning. The system uses flaps to control air volume of fresh air into the two-dehumidifier units. The opening and closing of the system provide inspiration from the leaf-cutting ants' strategy for mound ventilation. The prairie dog offsets and shape of borrow mounds entrances improve the location and shaping of fresh air inlet and return air outlets on the exterior and interior side of building envelope. The regenerator uses solar radiation in the regenerator of the liquid desiccant as a case for system exergy. Future work can improve understanding of energy storage by varying concentration levels. Direct evaporative cooler transfers waste heat from fresh air to exhaust air and conserve energy. The use of other low-grade heat source exchanges provides dry air ventilation and chiller water for radiant ceilings (Yin, Zhang and Chen 2008). Water condenses on the underside of the regenerator glass and flows downward to the collection reservoir. Water use and water use intensity per square meter improves the study of work for water harvesting from the solar regenerator. Future work in calculating building envelope air mass and vapor conversions improves latent energy transformations for condensation and evaporation mass balance, and evaluation of the integrated components. The long lead-time in developing improvements system design shortens with the strategic bio-inspired design process but this requires an integrative approach with engagement with agents from other areas of design, engineering, structure, building science, and biology. In light of these constraints, multiple areas for improvement give rise to breaks in barriers for re-think of alternative decoupling air-conditioning systems that can be responsive to ecological and thermal issues.

REFERENCES

- Bollazzi, M., L.C. Forti, and F. Roces. "Ventilation of the giant nests of atta leaf-cutting ants: does underground circulating air enter the fungus chambers?" *Insectes Sociaux*, 2012: 487-498.
- Dieckmann, John, Kurt Roth, and James Brodrick. "Liquid desiccant air conditioners." *ASHRAE Journal*, 2008: 90-95.
- Gandhidasan, P., and M. Mohandes. "Artificial neural network analysis of liquid desiccant dehumidification." *Energy*, 2011: 1180-1186.
- Grondzik, Walter T., Alison G. Kwok, John S. Reynolds, and Benjamin Stein. *Mechanical and electrical equipment for buildings*. Hoboken: John Wiley and Sons., 2006.
- Hubbard, Arthur J., and George Hubbard. *Neolithic dew-ponds and cattle-ways*. London: Longmans, Green and Co., 1916.
- Kleineidam, Christoph, Roman Ernst, and Flavio Roces. "Wind-induced ventilation of the giant nests of the leaf-cutting ant atta vollenweideri." *Naturwissenschaften*, 2001: 301-305.
- Kreider, Jan F. and Rabl, Ari. *Heating and cooling of buildings: design for efficiency*. New York: McGraw-Hill, Inc., 1994.
- Nikolayev, V.S., D. Beysens, A Gioda, I. Milimouka, E. Katiushin, and J.P. Morel. "Water recovery from dew." *Journal of Hydrology*, 1996: 19-35.
- Pawlyn, Michael. (2011). *Biomimicry in architecture*. London: Riba Publishing.
- U.S. Department of Energy (DOE). *2011 buildings energy data book*. Buildings Technologies Program Energy, 2012.

- Yin, Yonggao, Xiaosong Zhang, and Qingyan Chen. "A new liquid desiccant system for air-conditioned spaces with high latent and cooling load." *International Refrigeration and Air Conditioning Conference*. Paper 861, 2008. 8.
- Yin, Yonggao, Xiaosong Zhang, and Zhenqian Chen. "Experimental study on dehumidifier and regenerator of liquid desiccant cooling air conditioning system." *Building and Environment*, 2007: 2505-2511.
- Yu, B. F., Z. B. Hu, M. Liu, H. L. Yang, Q. X. Kong, and Y. H. Liu. "Review of research on air-conditioning systems and indoor air quality control for human health." *International Journal of Refrigeration*, 2009: 3-20.

Intelligent structural adaptability

Hollee Hitchcock Becker¹

¹The Catholic University of America, Washington, DC

The average life of a building in Tokyo is six years. The average life of a building in the United States is thirty-one years. Buildings are typically replaced for reasons other than the building itself including high operational costs, increased density requirements, or new programmatic needs. Building structures are typically designed so efficiently that little or no upward expansion can be made without a change in the existing structure. Limited resources, climate change and new technology direct changes in design thinking and yet designers still structurally design for present conditions with little thought for resiliency or adaptability.

The environmental impact of renovation or replacement considers the material and operational attributes of a building; a method justifying its replacement in some cases. But, the material impact of designing for future expansion will always be less than demolition and replacement due to the simple fact that no matter the original size or replacement size, the difference between the two scenarios is the embodied energy in the original building plus that in demolition. The question therefore is why don't developers think ahead? The answer lies in either economics or the uncertainty of future use.

This paper posits that cities will become denser requiring continued addition of height to existing buildings. It investigates the environmental and economic impact of designing for longevity by comparing strategies for the design of structural systems for future expansion to the design of present conditions. This paper speculates on the structural impact of the development of new materials with higher allowable stresses and lighter densities as well as the impact of robotic construction.

KEYWORDS: Structural Resiliency, Embodied Energy, Structural Efficiencies

INTRODUCTION

Climate Change, population growth, cultural/social – lifestyle changes and limited global resources are all factors that indicate a need for resilient design. Between 1990 and 2013 there was a 34% increase in global warming effect caused by greenhouse gases.(WMO 2014). Between 2012 and 2013, the increase in Carbon Dioxide was the largest in thirty years. Carbon Dioxide currently accounts for about 65% of the radiative forcing by global greenhouse gases. Buildings contribute to the increase in carbon dioxide through the burning of fossil fuels for heat energy and through the manufacturing and processing of building materials. Therefore, from a structural point of view, it is in global best interest to reduce the embodied energy in construction materials and processes. Global warming is indicative of climate change. An increase in weather extremes is predicted including a change in cyclone patterns. *Climate Change 2007: The Physical Science Basis* (Meehl 2007, p.768) predicts cyclone patterns will move farther from the equator subjecting cities as far north as 40 degrees latitude to winds in excess of 150mph. Changes in wind speed indicate necessary changes in design loads for lateral force resistance.

The World Health Organization reports on their Global Health Observatory site that 54% of the population currently live in urban areas, and increase from 34% in 1960. The WHO predicts that urban populations will grow by 1.84% per year in the next 5 years, 1.63% per year between 2020 and 2025 and 1.44% between 2025 and 2030. (WHO 2014). The United Nations Department for Economic and Social Affairs/ Population Division's World Urbanization Prospects: The 2011 Revision (Heilig 2012) predicts a 75% increase in urban populations by 2050 with a rise from 3.63 to 6.35 billion people. Any increase in urban population will require an increase in urban density. Urban densification is already apparent with the destruction of structurally sound buildings to make way for taller projects. The Athena Institute conducted a three year study in Minneapolis/St. Paul (Athena 2004) and found that of the 227 structures demolished during the three and one half year period from 2000 to mid-2003, only 31% were demolished due to the physical condition of the building and 7% from fire damage, while 57% were demolished because of area redevelopment or because the structure was not suitable for anticipated use. Only one third of the demolished structures were made of concrete and steel, but of those, 63% of concrete structures and 80% of steel structures demolished were under 50 years old.

1.0 NOW OR AGAIN

1.1. The logic of planning ahead

Buildings are typically replaced for reasons other than the building itself including high operational costs, increased density requirements, or new programmatic needs. Yet developers generally do not plan for future use either for economic reasons or because of the uncertainty of future use. Developers rely on an economic argument for demolition and rebuild. Given the time value of money, is it better to spend additional money from the project budget on structural design for future expansion or design as efficiently as possible and demolish for rebuilding? Factors include the projected cost of limited resources in the future and the cost of waste disposal. There is an environmental argument for planning ahead. It ultimately saves resources. The environmental impact of renovation or replacement considers the material and operational attributes of a building; a method justifying its replacement in some cases. However, the material impact of designing for future expansion will always be less that of demolition and replacement. This is due to the simple fact that no matter the original size or replacement size of the structure, the difference between the planning ahead and demolition and replacement is the embodied energy in the original building structure plus that involved with demolition. Retrofitting is another factor that must be considered. Retrofitting keeps the initial building cost low and saves the financial and environmental cost of demolition, although it is not an easy task and not always cost effective. In order to determine the best approach to structural expansion, the possible strategies are defined based on designing structure for future expansion, demolition and rebuild, or retrofitting.

1.2. Possible expansion strategies:

The following options are the possible ways to approach future building expansion.

Option 1: Design for structural efficiency based on today's requirements for program and codes. This option would require the existing substructure and superstructure to be demolished and a new structure built when expansion is required.

Because the foundation of a building is the most difficult to replace or retrofit and therefore most expensive portion of the structure to remove or retrofit for additional levels, options 2 and 3 focus on the design of the foundation only for future expansion while the superstructure is designed for immediate programmatic needs. In the future, the superstructure would require either retrofitting or demolition. These options are advantageous in that the embedded energy in the foundation is not wasted and the expense of concrete removal, earthwork, formwork and new concrete placement is spared.

Option 2: Design the substructure for future expansion but demolish and rebuild the superstructure.

Option 3: Design the substructure for future expansion and retrofit the superstructure to meet expansion demands.

Options 4: A comprehensive future design strategy - Design the substructure and superstructure to support future loads consistent with projected increase in urban density for a given area. This option can be subdivided into two categories: one accommodating continued use of the building during expansion and the other requiring the building to be vacated during construction.

2.0 MATERIAL MATTERS

2.1. Material amounts

As an example for calculation purposes, an infill lot providing a building outline of 60ft by 120ft is divided into 9 bays 20ft by 40ft each. The floor to floor height is 12ft and the construction is A992 Structural Steel.

Based on a need for 75% more urban population in the next 50 years, the additional steel required in the initial stage of development to allow for the addition of 75% more levels in 50 years was calculated for initial heights of 4, 8, 12, 16, and 20 levels. Only gravity loads (factored live and dead loads) were considered. Only about 40% of steel framing costs come from the actual material costs itself, and 1% from transportation (building.co.uk 2012). Further, estimating that structural costs in multi-residential projects are 15% (SteelConstruction.info 2012) of the total project costs with superstructure estimated at 10% and substructure estimated at 5%, yields an increase in project cost due to an increase in steel of only $.1 (.41) = .041$ times the additional steel percentage. The result of planning for 75% expansion adds less than 0.3%

additional steel cost to the project due to superstructure design.

If the superstructure is designed for additional levels, the substructure must also be designed for additional levels. Material cost of concrete in a concrete foundation system is estimated to be 50% of total foundation costs and foundation costs are estimated at 6% of total project costs. Given this, the increase in project cost due to planning the substructure structure for future expansion loads yields (percent concrete volume increase)(.5)(6%) = .03 times percent concrete volume increase.

Taken together, the increase in total project costs from 75% substructure and superstructure expansion planning is 4.7% or less for midrise structures. Using the same assumptions, designing for 100% expansion creates 5.2%, and a 200% expansion creates 10.7% or less additional total project cost. In every scenario with a mat foundation, the additional concrete required for planning ahead incurs over 93% of the additional project cost.

Table 1: Additional Project costs for Option 4 relative to Option 1 with Mat Foundations.

MAT FOUNDATION								
75% additional levels planned		STEEL STRUCTURE			CONCRETE STRUCTURE			
Stage 1 number of levels	Stage 2 Add'l levels	% add'l stage 1 steel	% add'l stage 1 concrete	% Additional Project Cost	% add'l stage 1 columns	% add'l stage 1 ftg.s	% Add'l Project Cost	
2.0	2.0	1.5	156.0	4.7	0.0	156.0	4.7	
3.0	3.0	3.0	97.0	3.0	0.0	97.0	2.9	
4.0	3.0	3.3	78.0	2.5	0.0	78.0	2.3	
5.0	4.0	4.2	100.0	3.2	0.0	100.0	3.0	
6.0	5.0	5.2	111.0	3.5	0.0	111.0	3.3	
7.0	6.0	6.1	123.0	3.9	0.5	123.0	3.7	
8.0	6.0	6.2	118.0	3.8	0.9	118.0	3.6	
9.0	7.0	7.0	124.0	4.0	1.9	124.0	3.8	
10.0	8.0	7.9	138.0	4.5	2.9	138.0	4.3	
100% additional levels planned		% add'l stage 1 steel	% add'l stage 1 concrete	% Additional Project Cost	% add'l stage 1 columns	% add'l stage 1 piles	% Add'l Project Cost	
2.0	2.0	1.5	156.0	4.7	0.0	156.0	4.7	
3.0	3.0	3.0	97.0	3.0	0.0	97.0	2.9	
4.0	4.0	4.4	109.0	3.5	0.0	109.0	3.3	
5.0	5.0	5.2	121.0	3.8	0.0	121.0	3.6	
6.0	6.0	6.2	144.0	4.6	0.3	144.0	4.3	
7.0	7.0	7.1	157.0	5.0	1.1	157.0	4.8	
8.0	8.0	8.0	164.0	5.2	2.2	164.0	5.1	
9.0	9.0	8.9	163.0	5.3	3.3	163.0	5.1	
200% additional levels planned		% add'l stage 1 steel	% add'l stage 1 concrete	% Additional Project Cost	% add'l stage 1 columns	% add'l stage 1 piles	% Add'l Project Cost	
2.0	4.0	4.2	282.0	8.6	0.0	282.0	8.5	
3.0	6.0	6.1	225.0	7.0	0.0	225.0	6.8	
4.0	8.0	11.4	264.0	8.4	0.5	264.0	8.0	
5.0	10.0	10.3	303.0	9.5	2.3	303.0	9.2	
6.0	12.0	12.0	335.0	10.5	4.6	335.0	10.3	

Not every urban structure will be replaced or expanded to new heights in order to accommodate a 75% increase in urban density. Urban areas with low to mid-rise structures are most likely to see densification. With that in mind, I posit a scenario in which urban buildings with two to four levels will be replaced or expanded to four times their original height. Foundations for low rise structures may consist of individual footings but as the number of levels rises, individual footings no longer are practical and should be replaced by piles. This is because the required width of the footing becomes exceedingly large, especially with low soil bearing capacity. Even with a soil bearing capacity of 5000psf, the building scenario studied would be limited to 18 levels using a shallow foundation.

If friction piles are used in place of a mat foundation, increased project costs are greatly reduced, dropping from 4.7% to 1.1% for a planned expansion of 75%; 5.2% to 1.3% for 100% expansion planned; and 10.7% to 2.4% for 200% expansion planned.

Table 2: Additional Project costs for Option 4 relative to Option 1 with Driven Pile Foundations.

DRIVEN PILE FOUNDATION							
75% additional levels planned		STEEL STRUCTURE			CONCRETE STRUCTURE		
Stage 1 number of levels	Stage 2 Add'l levels	% add'l stage 1 steel	% add'l stage 1 pile steel	% Add'l Project Cost	% add'l stage 1 columns	% add'l stage 1 piles	% Add'l Project Cost
2.0	2.0	1.5	41.5	1.1	0.0	47.9	1.4
3.0	3.0	3.0	41.5	1.1	0.0	45.5	1.4
4.0	3.0	3.3	32.3	0.9	0.0	34.7	1.0
5.0	4.0	4.2	34.2	1.0	0.0	36.1	1.1
6.0	5.0	5.2	35.4	1.1	0.0	37.1	1.1
7.0	6.0	6.1	36.3	1.1	0.5	37.7	1.2
8.0	6.0	6.2	32.3	1.0	0.9	33.4	1.1
9.0	7.0	7.0	33.4	1.1	1.9	34.4	1.1
10.0	8.0	7.9	34.2	1.1	2.9	35.1	1.2
100% additional levels planned		% add'l stage 1 steel	% add'l stage 1 pile steel	% Add'l Project Cost	% add'l stage 1 columns	% add'l stage 1 piles	% Add'l Project Cost
2.0	2.0	1.5	41.5	1.1	0.0	47.9	1.4
3.0	3.0	3.0	41.5	1.1	0.0	45.5	1.4
4.0	4.0	4.4	41.5	1.2	0.0	44.4	1.3
5.0	5.0	5.2	41.5	1.2	0.0	43.7	1.3
6.0	6.0	6.2	41.5	1.3	0.3	43.3	1.3
7.0	7.0	7.1	41.5	1.3	1.1	43.1	1.4
8.0	8.0	8.0	41.5	1.3	2.2	42.8	1.4
9.0	9.0	8.9	41.4	1.4	3.3	42.7	1.5
200% additional levels planned		% add'l stage 1 steel	% add'l stage 1 pile steel	% Add'l Project Cost	% add'l stage 1 columns	% add'l stage 1 piles	% Add'l Project Cost
2.0	4.0	4.2	73.4	1.9	0.0	83.7	2.5
3.0	6.0	6.1	73.3	2.0	0.0	79.8	2.4
4.0	8.0	11.4	73.3	2.2	0.5	78.0	2.4
5.0	10.0	10.3	73.3	2.2	2.3	77.0	2.4
6.0	12.0	12.0	73.3	2.3	4.6	76.3	2.6

2.2. Material types

Not all buildings are constructed of steel. An identical column grid and floor-to-floor height constructed of concrete yields different results. Given the design criteria of a slenderness ratio less than 22 for short concrete columns and an unbraced length of 12ft, the minimum width for a square column would be 22.67". This number would be rounded up to 24". This means that for future building expansion to a total of 11 levels or less, the only additional initial cost to the superstructure would be the amount of rebar in the columns. The total impact on project cost from additional column concrete would be .5(.12)(percentage increase in concrete volume). Using mat foundations, the change in Project Cost due to planning for expansion in concrete construction is only 0.3% greater than with steel construction.

It should be noted that while the examples listed are structures steel and concrete structures, most multifamily housing in the United States four levels or less has western frame construction. Western frame buildings cannot be expanded with additional levels due to code restrictions and therefore must be demolished if expansion is desired. Since the only option for western frame construction is Option 1 or Option 2: discussion of this type using western framing must be considered for economic reasons, named Option 1A and Option 2A.

3.0 MONEY MATTERS

3.1. The time-value of money for the next 50 years.

The Federal Government targets a 2% annual inflation rate, although that number is seldom met. The average in the past fifty years is 4.48%. With some annual inflation rate (i), the cost of project construction in fifty years would be today's project cost times $(1+i)^{50}$; meaning that at 2% annual inflation, the same project cost in fifty years would cost $1.02^{50} = 2.69$ times the cost today.

Using assumptions of \$250/sf for construction, \$200/sf for retrofitting, and \$100/sf for demolition and an annual inflation rate of 2%, the costs in 2065 would be \$673/sf for construction, \$538/sf for retrofitting and \$269/sf for demolition. The following results were obtained:

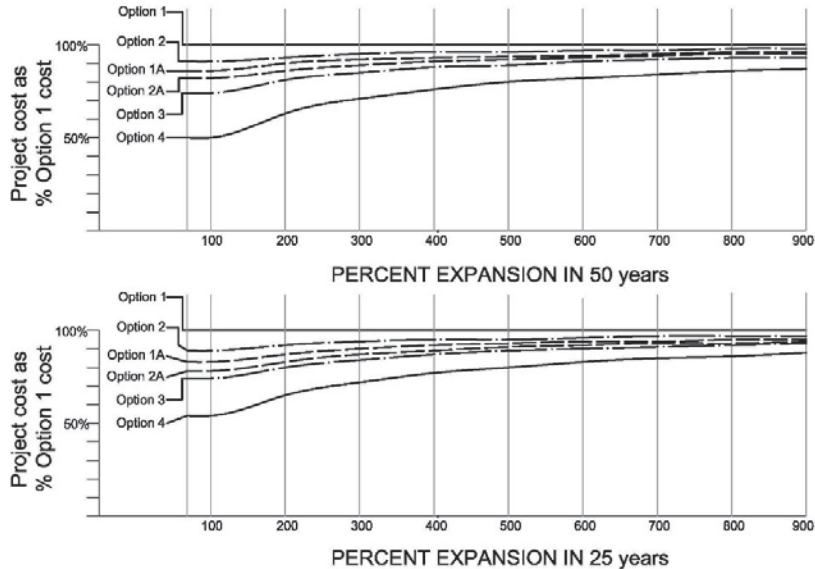

Figure 1: Comparison of project costs for all Options as a percentage of Option 1.

As mentioned previously, most multifamily housing in the United States having four levels or less is western frame construction. Four-level western framing cannot be expanded due to code restrictions and therefore must be demolished if expansion is desired (Option 1). Not only is western framing inexpensive to build; demolition is efficient and inexpensive compared to steel or concrete structures. In consideration of this, a construction and demolition rate for Stage 1 western construction was given at 50% of the costs listed above for Option 1A and Option 2A.

Regardless of the amount of planned expansion, *Option 4: Design both substructure and superstructure for future expansion* is the most economical choice, followed by Option 3, Option 2A, Option 1A, Option 2 and finally Option 1. Options 1 and 2 plan for demolition of the stage one steel superstructure, whereas Options 1A and 2A plan for demolition of a western frame superstructure.

Another consideration is the fact that demand may allow a developer to expand before fifty years. A change in the number of years before expansion has no effect on the order of efficiency of the expansion Options and very little change on the actual efficiency relative to Option 1.

The problem with predicting future rates is that no one can really predict the future. If waste disposal costs skyrocket, so will demolition costs. If steel prices drop or construction costs plummet due to affordable robotic construction methods, construction and renovation costs will vary. If material shortages occur, alternate materials will become prevalent. If alternate materials are used, new building technologies will develop. If climate change continues unchecked, higher lateral forces and greater thermal expansion will change structural design. Given these uncertainties, the analysis was run again using 50% of former demolition and retrofitting rates. The results remain the same. If inflation rates change from the Federal goal of 2%, even as little as 1%, then the savings value of Option 4 will inversely change by about 3%.

3.2. Building occupancy during expansion

Building occupancy during expansion can only occur in Option 4 where no structural demolition or retrofit is required and possibly in Option 3 where superstructure retrofit is required and partial occupancy may occur. Occupying all or part of a building during expansion presents a number of problems. Building Access to occupants and workers need to be defined for safety and security reasons. If freight elevators are limited to expansion construction use, it precludes or impedes the moving of large items by occupants, trash removal and the like. Acoustic comfort is a major concern. Structure-borne sound, especially during steel modification, intensifies the noise distraction caused by construction. Ventilation and cooling equipment located on the roof needs to be relocated or replaced and other MEP systems will require temporary shut off points. The only advantage to occupying a building during expansion is monetary and this advantage only occurs if the additional cost of construction is outweighed by the lease income revenue.

4.0 EMBODIED ENERGY

Using the Hammond & Jones Embodied Energy rating for materials (Hammond & Jones 2008), the embodied energy in the production of structural concrete is 1.11MJ/kg and for structural steel with 42.3% recycled content, 24.40 MJ/kg. For demolition, energy rates are 0.301MJ/kg for steel and 0.107 MJ/kg for concrete. Steel has a high value and is easily reused or recycled. Concrete can be recycled, but at a higher cost and typically only about 73% of concrete is reclaimed as recycled (Athena 1997). A comparison of Options 1 and 4 for embodied energy reveals, as expected that the embodied energy in Option 4 is about 2/3 that of Option 1 for 75% expansion, but that as the rate of expansion increases, the difference in embodied energy for both stages between the two options decreases.

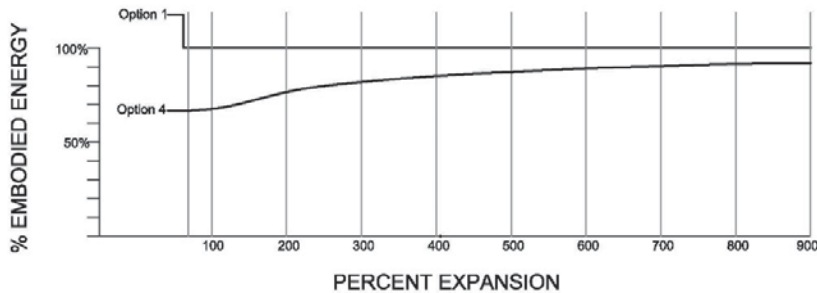

Figure 2: Embodied energy for Option 4 relative as a percentage of Option 1.

5.0 NICOMACHEAN ETHICS

Cowee and Schwehr (Cowee 2012) liken adaptability to Aristotle's *Nicomachean Ethics* stating avoidance of excess at either end of the spectrum will produce the best model for sustainable and economic balance. A true nicomachean balance would require a monetary value for embodied energy in order to compare the differences between options for economics and sustainability combined. Using Option 1: Build – demolish as a baseline, Option 4: Build for expansion can be compared. The current average rate of electricity in the United States is about 0.12\$/kWh. This number converts to 0.00341\$/MBTU.

Factoring in Embodied energy costs does not significantly change the cost ratio between Option 1 and Option 4. Even an increase over 4000% in energy costs, raising the rate from .12\$/kWh to 5.0\$/kWh, still does not create a large enough shift to consider Option 1. The economical and sustainable choice is Option 4: Design both Foundation and Superstructure for eventual expansion.

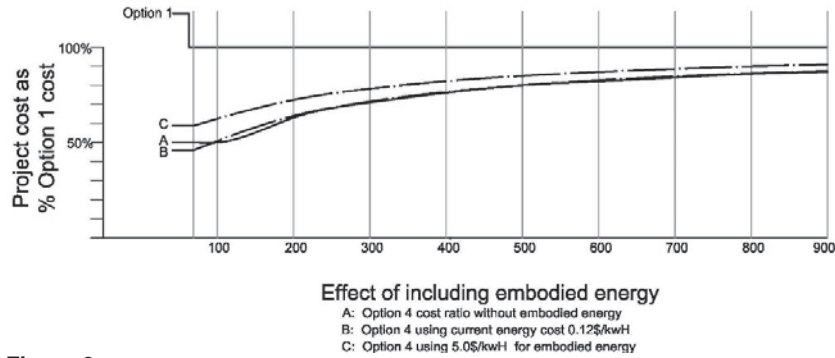

Figure 3: Comparison of Option 4 project costs using a dollar value for embodied energy cost.

The question becomes, if designing structure for future expansion is the best choice for both economics and sustainability, then why don't developers do it? The answer probably lies in the initial cost despite the project cost difference being less than 3%. 3% of a ten million dollar project is \$300,000. That amount does not include the cost of financing the \$300,000. It would seem the only motivation for a developer to spend the extra money up front is if he/she plans to retain the property and eventually expand it. The property would be more valuable if no demolition is required for expansion, but only if the existing structure is suitable for future design.

6.0 FLEXIBILITY

Stewart Brand's layer diagram from *How Buildings Learn* (Brand 1995) is meant to illustrate the changing nature of buildings as a result of differences in the longevity of its systems and components. Brand sees the structure of a building as the most permanent layer second only to site, which is how designers traditionally viewed structure: permanent and unchanging. This is a logical view given the cost of changing structural systems to adapt to new uses.

6.1. Unitization

Recently, there has been a surge of interest in transitory or "pop-up" structures and in prefabricated structural units that imply a flexibility. For prefabricated units that are infilled into an existing structure, the structure is designed to carry loads resulting from being fully loaded with units. For prefabrication that relies on the stacking of units, every unit must be over-designed in order to support the number of units that could possibly be placed atop it. Although schematically and financially there is much flexibility, structurally unitization is not inherently efficient. A module 20' by 20' by 12' high designed for stacking would use about 75% more steel than the steel structure of an equivalent height as described for earlier analyses. The total project cost would increase due to the amount of steel used and cost of module transportation and lifting, but decrease due to the efficiencies of prefabrication such as building under controlled conditions with higher levels of automation and incurring less on-site time.

6.2. Change of use

In one sense, the permanent nature of structure reinforces the idea of planning ahead. However, there are scenarios in planning for expansion where the structure of existing levels may change significantly. For example, if a site is designed to house a large open space for several years before building a residential tower atop, the stage 1 structural system could have perimeter walls supporting a space frame. The space frame would be removed and additional columns placed to support the stage 2 tower. This scenario is neither static nor flexible and suggests that structural planning for future expansion be limited to cases where stage 1 and stage 2 uses employ the same structural system type.

Another consideration is the development of new and better structural materials. Grade 5 Annealed Titanium (Ti6Al4V) has a compressive yield strength of 125ksi compared to A995 Steel at 50ksi. Logic dictates titanium design would use $50/125 = 40\%$ the volume of steel, which seems to be more efficient. Titanium density is 56% that of steel but costs 10 times as much. Given this, the cost of a titanium structure would be $0.4(0.56)(10) = 2.24$ times the equivalent in steel. What's worse, the embodied energy per pound of Titanium is 16.4 times that of steel meaning a Titanium structure has $(0.40)(.56)(16.4) = 3.67$ times the embodied energy of the equivalent in steel. Should processing methods change reduce embodied energy and cost, Titanium could become a staple in the building industry.

Laminated Bamboo has a compressive yield strength of 13.5ksi compared to A995 Steel at 50ksi. Logic dictates titanium design would use $50/13.5 = 370\%$ the volume of steel. Laminated Bamboo weighs 9.8% the weight of steel and costs 4.15 times as much. Given this, the cost of a laminated bamboo structure would be $3.7(0.098)(4.15) = 1.5$ times the equivalent in steel. However, the embodied energy per pound of Laminated Bamboo production is about the same as steel meaning a Laminated Bamboo structure has $(3.7)(.098)(1) = 0.36$ times the embodied energy of the equivalent in steel. This is a case where a reduction in price and a change in building codes could trigger more use of Laminated Bamboo structures. Still, the impact on expansion would be minimal because although the weight of the structure is reduced, the other dead loads and the live loads will remain the same.

7.0 DESIGN LIMITATIONS

It is concluded that structural planning for future expansion is the economic and sustainable choice if the existing structure is suitable for the expanded use. This logic acknowledges the design limitations imposed on the stage 2 designer. That said, it must also be acknowledged that both client and designer may find the existing structure unsuitable for the vision of the next building use. This is not necessarily an arbitrary aesthetic choice. The change in design strategies, building construction and consumer values are constantly changing. The last two big changes in structural design were the development of steel frame systems to allow curtain wall construction and the development of computer-aided design to allow complex shape analysis and fabrication. To assume that there will not be another big change in the next fifty years would be naïve. Yet, a survey of the structural types employed today shows most buildings employ a beam and column system of steel and/or concrete in fairly orthogonal form. This does not mean that future expansion must follow suit; it is the challenges of limitations that brings ingenuity to the design process.

REFERENCES:

- Athena Institute, 2004. *Minnesota Demolition Survey: Phase Two Report*.
- Athena Sustainable Materials Institute, 1997. *Demolition Energy Analysis of Office Building Structural Materials*, Ottawa, Canada.
- Brand, Stewart, 1995. *How Buildings Learn: What Happens After They're Built*, Penguin Books.
- Building.co.uk, 2012. Steel insight: Cost Planning through design stages, <http://www.building.co.uk/steel-insight-cost-planning-through-design-stages/5034975.article>
- Cowee, Natalie and Peter Schwehr, 2012. *The Typology of Adaptability in Building Construction*, VDF Hochschulverlag.
- Hammond, G.P. & Jones, C.L., 2008. *Embodied Energy and Carbon in construction materials*, Proceedings of the Institution of Civil Engineers, Energy, 161 (2): 87-98.
- Heilig, Gerhard, 2012. *World Urbanization Prospects: The 2011 Revision*, United Nations, Department of Economic and Social Affairs.
- Meehl, Gerald, T. Stocker, 2007, *Climate Change 2007: The Physical Science Basis*, ch.10, Cambridge University Press, Cambridge, UK and New York NY, USA.
- WMO Greenhouse Gas Bulletin, No.10/ 9 September 2014, World Meteorological Organization
- WHO Global Health Observatory, 2014
http://www.who.int/gho/urban_health/situation_trends/urban_population_growth_text/en/

Fusing design and construction as speculative articulations for the built environment

Stig Anton Nielsen¹, Alexandru Dancu¹

¹Chalmers University of Technology, Dept. of Architecture, Göteborg, Sweden

ABSTRACT: Dry stone constructions date as far back as 9000 BC and are associated with the first stable human settlements in the cradle of human civilization. Agricultural tools and permanent settlements led to sustained domestication of crops, and consequently a continuous co-evolution of humans and their environment.

The tools adopted widely by contemporary society are related to processing and visualizing information. It has been suggested that based on the information gathered from the environment, architecture itself could become responsive to the real environment.

This research seeks to attain a constant modification of the built environment on a small scale, rather than a large scale stepwise engagement. We suggest that representations of information should be closely coupled with the built environment, and that the built environment should be conjoined in real-time communication with multiple different representations, enabling sense-making and suggesting potential future states.

Through physical construction and design experimentation, representations of potential modifications, or articulations, are overlaid onto the environment. It is however important that these articulations be in constant flux based on the ongoing communication between environment and representations of it.

We propose a computational material supported by a framework that would link computation and environment in constant bi-directional communication and continuous, stepwise development.

We propose a methodology composed of scanning the environment, real-time computation, guidance, and construction visualization that would lead to a new approach of evolving the digital into a new physical reality. Future mixed reality architecture applications could make use of computational composites in order to fuse design and construction.

KEYWORDS: Dry Stone, Mixed Reality, Computational Composite, 3D Scanning, Augmentation

INTRODUCTION

Dry stone constructions are found throughout history and date as far back as 9000 BC (Schmidt, 2000). They have been associated with the Fertile Crescent and the first human settlements, as the source for human civilization transitioning to a society with stable settlements. The agricultural tools and permanent communities led to sustained domestication of crops, and consequently a continuous co-evolution of humans with their environment. (Brown, 2009) (Harris, 1989). The most influential tools adopted widely by society today are related to processing and visualizing information. Architecture has not been ignored by the information processing revolution. It has been suggested that based on information gathered from the environment, architecture could become "responsive to evolving in not just a virtual but a real environment" (Frazer, 1995).

In this paper, we suggest linking physical environments, based on their optical properties, to digital processing capabilities with the purpose of fusing design with construction. We exemplify how to achieve this by implementing a framework that supports the construction of dry stone walls on site in real time. The construction process requires natural stones of any size, a mobile display, a depth sensor, and a computing device.

We obtain insights and find the requirements needed to build a dry stone wall through an experiment that employs human skills that could in future be replaced by computational capabilities. As the design and construction process becomes augmented by sensors and computation, we speculate on distinct types of articulations and communications that could occur. Material and visual articulations both become embodied in the fabric of the environment.

Societies and cultures change rapidly, and computation can be used in the built environment to follow, articulate, and accommodate constantly changing needs at the speed which they arise. If indeed our future condition will be that of energy and material scarcity, the construction industry—starting with architects—should consider the standing building stock as their main matter to work upon and modify, upgrade and accommodate to changing needs. Rather than large scale interventions, where demolitions are necessary to make way for entirely new constructions, small scale iterations should constantly improve and adapt spaces, buildings, urban space, and city parts.

As such an approach requires a vast understanding of existing spaces, buildings, and the spaces in between, we need systems and techniques to modify the high complexity of the existing built environment. In addition, as this approach would lead to an increase in the number of interventions at different locations, we must invent tools to manage these multiplicities both locally and city-wide. In order to link computation and environment, representations must be closely overlaid with the natural and the built environment in constant communication with the computation system. Through sensors, representations, and articulations, computation can become embodied within the environment.

Cognition in changing environments and the handling of non-uniform objects is not a trivial task. In 1991 Rodney Brooks published the article '*Intelligence without representation.*' He proposed constructing robots using a type of cognition system different from traditional AI, which tries to create for the robot an internal cognitive model of its surrounding environment. Instead, Brooks' robots successfully use the environment as its own model (Brooks, 1991). Additionally, Christopher Alexander's research on vernacular architecture suggests that using the environment and matter as its own model has actually been performed successfully over centuries. Immediate interactions between users and the built environment have been the driving forces behind the vernacular traditions (Alexander, 1964).

In this paper we will discuss an experiment relying on multiple computational processes that guide a physical construction. We will discuss how potential modifications and articulations can be overlaid onto the environment and how to achieve a bi-directional communication between the virtual and the physical.

1.0 Mixed reality in architecture

Augmented Reality Aided Design has been proposed for architecture because it could enhance decision making, assist in the understanding of complex spatial arrangements, and offer information that would be "*displayed where it occurs*" (Seichter, 2003). Seichter focuses on design sketching in augmented environments, pointing out the importance of representation and interaction for "*perceptive performance.*" More recent work in immersive projected environments is the embodied interface for collaborative 3D sketching (Dorta, 2014). Novel interaction and visualization techniques have been proposed for use in architecture sketching.

Abboud identifies opportunities and obstacles for mobile augmented reality (MAR) in design, construction, and post-completion, supported by a number of use cases for each phase (Abboud, 2014). Opportunities identified for MAR are: overlaying a site with the intended virtual design, scale and clash detection can be explored by overlaying virtual objects on top of physical markers, augmented physical presentation media would overlay 4D data, such as traffic flows, shadow studies, and wind flows to inform the design process, communicating architectural narratives, and as a new interface between the virtual and the real. The latter opportunity does not present a use case, but the author suggests that

AR will continue to alter this understanding and perception of the built environment. Architects would do well to consider the possibilities enabled by AR, and seek to involve themselves in the design of future places that straddle the digital and real.

In this paper, we overlay a site with virtual objects by using inherent markers, but also create a new interface between the virtual and the physical. The overlay was enabled by using a depth sensor and a state-of-the-art real-time reconstruction software (Niessner, 2013) that enables scanning the environment and the granite. The new interface is created by fusing design and construction, and proposes a new use case that, to our knowledge, has not been yet identified or explored, namely assisting real-time dry stone wall construction based on locally available materials. For these reasons, we would not call our work Augmented Reality, but rather Mixed Reality on the continuum between the virtual and what is, or becomes physical (Yuichi and Tamura, 1999; Tamura, 2001).

1.1. Computational composites

Vallgård and Redström introduce the concept of the computational composite, which suggests using computation as a material and how this should be combined with other physical materials (Vallgård and Redström, 2007). In order to develop a computational composite useful in dry wall construction, the experiment needs to have a source of input, data computation, and a way of directing the output data to the

correct position in the environment. We do not create these systems from the ground, instead we employ low-cost hardware and state-of-the-art open source components to make up our framework.

When creating physical material composites the amount of each component as well as the contact method determines the success of the composite in attaining the intended properties. In our experiment, the computational component is inherent and ingrained to the surface of the stones. We use the visual appearance of the granite as a strong, accurate “glue” for the computation to adhere to. The surfaces are good for the purpose, because they are different for each side of the stone and unique for each stone. Consequently, the computer vision system is able to attach to them accurately because it can identify each unique surface. As non-embedded sensor systems usually need orientation within global cartesian coordinates, this visual adhesion effectively manages a bi-directional flow of information, and lets the matter and computation become embodied as a composite.

1.2. Fieldstone and dry stone walls

Among the first permanent human settlements are those associated with the Fertile Crescent dating back as far as 9000 BC (Schmidt, 2000). With the emergence of stable settlements using dry stone, the ground was set for human civilization. Setting dry stone constructions does not require mortar, but rather works by carefully selecting stones that interlock with each other to create a stable body. This selection process is not trivial, so it led to carving stones symmetrically so they would be easy to assemble. Carving requires tools, intense time and energy. In this paper, we propose minimizing the stone fitting selection process through machine computation.

Fieldstone is the common natural stone found in the surface soil of farmlands and forests. The structure and properties are different depending on the local geological conditions. For centuries farmers have been ridding their lands of stones for the purpose of farming, creating dykes from the piled stones. Dykes and dry stonewalls can have many purposes and degrees of sophistication. Walls can contain livestock, or secure soil from erosion, and are often seen holding terraced fields in place. Common among them all is that they do not use mortar, relying on compression forces, and in some cases built with a technique using interlocking stones. The advantages of the permeable structure of a drystone wall are many, for example water drainage and habitation, encouraging biodiversity (Thompson, 2006).

As our experiment was based in Sweden where the ground is rich with granite, we found this a natural choice of material. Most historical structures of fortification in Sweden used granite, but for modern constructions only the foundations are set in granite. For our experiment we found large amounts of chopped granite available near the university campus. Because granite contains different minerals, the surface texture is often very distinct and full of contrast, unique for each stone and every side of the stone. This makes it well suited for state-of-the-art pattern recognition.



Figure 1: A natural granite stone with scale markings on three sides.

Figure 2: The pattern of the side marked B.

Figure 3: This seemingly homogenous pattern of another granite stone also used for pattern recognition.



Figure 4: Galloway dyke on Fetlar, Shetland Islands, UK.

Figure 5: The Lion Gate of the Mycenae acropolis is a dry wall.

2.0 EXPERIMENT

2.1. Building a natural stone wall

Building good solid dry stone constructions requires a high level of skill, and the process is inherently indeterminate. Normally it is not possible to plan more than a few stones ahead, and the structures will be asymmetric and are never the same. Despite the repetitious process of placing stones the situation is constantly changing, unlike the process of bricklaying masonry. The experiment focuses on some aspects within automation which are already defined as difficult, namely that of uncharted changing environments and the handling of differentiated elements (Benedict and Osborne, 2013). The difficulties of constructing with natural materials in a constantly changing environment makes it an intriguing challenge.

An architecture student shared his experience and the difficulties involved in building a stone wall, using naturally shaped granite stone and mortar, as part of his Masters thesis. Figures 6, 7 and 8 show one of his walls under construction. His first hand description follows:

The hardest part was finding a good fit for the stones, and searching for a good shape. Also if you arrange a few stones that fit together on the wall, you have to remove them in order to apply the mortar. And then you immediately lose track to where they fitted.

We built a concrete block wall of the same size in around 4-6 hours. But I am an amateur builder of course, and only have good technical knowledge of masonry. Although we did try to hire professional masons, they didn't know how they would do it with irregular stones. And they were really reluctant to give it a try.

So it's hard and time consuming, but it seemed like a good idea at the time to use the material on site.



Figures 6, 7 and 8: The natural stone wall here is not a dry wall, but rather bound by mortar.

2.2. Insights and building steps

To list the difficulties: A) Choosing a stone, B) Finding a suitable location for that stone, C) Applying the mortar, and D) placing the stone in the same location on the wall after applying mortar.

Then the procedure A through D is repeated until the wall is finished. The unskilled builder describes several difficulties, firstly step B: Finding a good fit for the stone and secondly, step D: replacing the stone after applying mortar. Of course if one chooses to build a dry stone wall, the replacement step is eliminated, but when studying videos demonstrating craftsmen building dry stone walls, it is clear that the most time consuming part is moving the stone around until it fits in a stable position (Switzer, 2011).

We need to describe the steps in the process in order to construct a computational composite, therefore we need to break it down into three computational steps.

- i) Scan the physical environment and granite using an off-the-shelf depth sensor (Kinect) and state-of-the-art reconstruction/scanning/mesh software, to label the granite.
- ii) Stepwise computation and positioning of the granite to satisfy certain criteria and predict/propose the next placement (step) in the construction process.
- iii) Real-time visualization and feedback of the state of construction.

Firstly we use a state-of-the-art 3D reconstruction method, to scan and represent the stones in a virtual physics simulation. We used a commonly available game engine with physics simulation and were able to iteratively test different placements of the stone. Once a good fit is found, the location is passed to the static surfaces or trackers which we know are existing in the environment. This way, through the use of pattern recognition, we are able to identify a relative location in the environment and present the different possible locations for the stone using augmented reality on a smartphone, tablet, or laptop. The next sections will describe these steps in more detail.

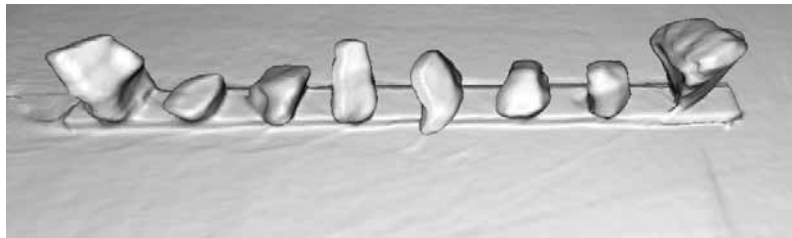

Figure 9: Individual scanned stones.



Figure 10: Scanned buildup.

2.3. Scanning environment and granite

The scanning process consists of two main parts: scanning the initial environment where rocks will be placed (Figure 10) and scanning individual stones (Figure 9). The state-of-the-art reconstruction method used for scanning (Niessner, 2013) proved to be robust in tracking and allowed us to acquire large environments. In our setup, we fixed the stones in styrofoam and scanned them all at once and then in post processing cut and patched the meshes.

The rock meshes were processed using the Meshlab software version 1.3.4. Individual stones from the large mesh containing 6 stones were cut by deleting the vertices of the other stones.

Then, based on the remaining vertices, the operation was run by selecting in Meshlab: Filters > Normals, Curvature and Orientation > Compute Normals from point sets (Neighbour number = 10, Smooth iteration = 0). To fill the holes that originated from deleting the base vertices, Poisson reconstruction was performed by the operation: Filters > Remeshing, Simplification, and Reconstruction > Surface Reconstruction: Poisson (Octree: 6, Solver Divide: 6, Samples per node: 1, Surface offsetting: 1), followed by a mesh reduction of polygons through the operation Quadratic Edge Collapse Decimation (Target number of faces: 255).

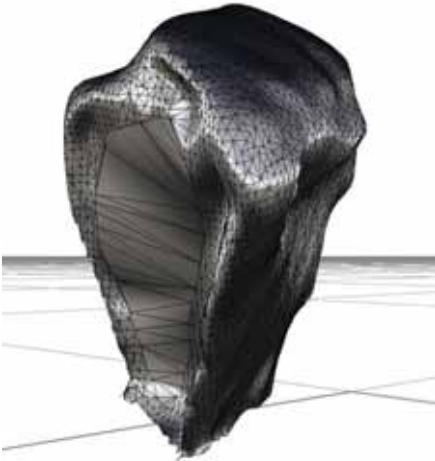

Figure 11: Mesh model of a scanned stone before of mesh processing.

2.4. Stepwise computation and placement of the granite

Placing and arranging a rock was implemented through a virtual physics engine, Unity, which can define meshes as objects with physical properties. Such objects will collide with each other and, based on the settings of their physical material properties, they can simulate bouncing elasticity and set the friction level. We implemented a script for dropping stones from different locations, with different rotations over the existing wall, and based on a set of criteria, decide whether it obtained a good placement or not. By manipulating the timescale in the Unity game engine, many iterations can be rapidly calculated.

A stone wall can have different purposes, but the main criterion is always that it should be stable and robust. The criteria for which we evaluate the position of the stone were therefore that the stone should be placed on the existing stones with well distributed points of contact, and that the surfaces of the connection should all be as horizontal as possible to lead the forces down and not to let the stone act as a wedge splitting the wall apart. Many other criteria can be important, such as to plane front alignment with intended front surface, as well as solidity.

The physics engine allows for opportunities entirely different from the physical world, and we made use of this in a few ways. Because the physics engine can change simulated physical properties of both environment and the stone instantly, we were able to create a stone that was slightly slippery and not bouncy in order to let it quickly find a good position. Then once a position that satisfied the two criteria is found, we can instantly stop its movement and change its physical properties to that of a real stone, so that friction would hold it in place and its mass would let it lie undisturbed by a newly instantiated stone that would then try to find its position iteratively.

We have not yet implemented criteria for creating a smooth outer surface of the wall or for optimizing volume or space fill, but the physics engine certainly can facilitate these opportunities.

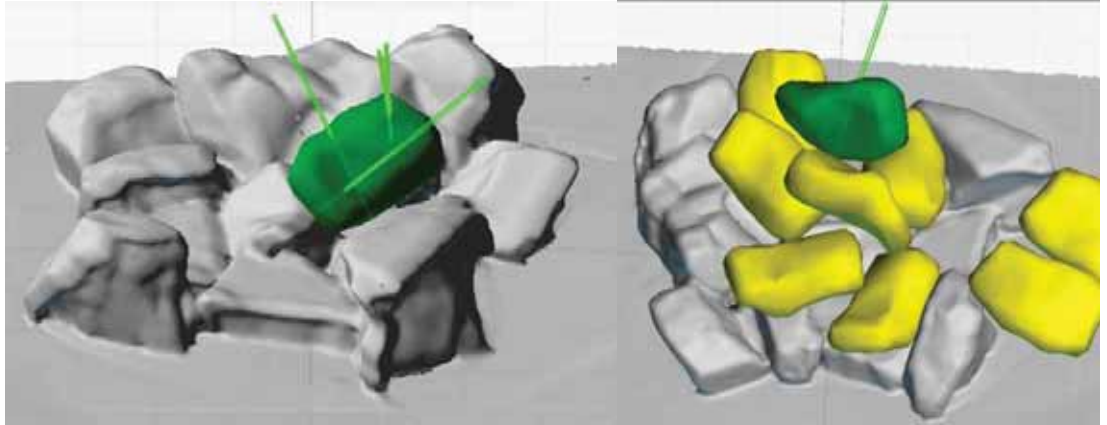

Figures 12 and 13: A stone finding its place, while the game engine evaluates the criteria for the normals and contact points.

2.5. Visualization and construction guidance

The 3D models of the granite were overlaid and aligned using the pattern recognition and extended mapping capabilities of the physics engine Unity and the augmented reality software platform Qualcomm Vuforia. Having a suitable placement of the granite rock in the virtual environment, we need to go ahead and place it in the actual environment. For this procedure we make use of a combination of commonly available hardware, namely an Android smartphone running Vuforia. This software allows us to assign flat surfaces from the stones as three dimensional placeholders. As all the stones have natural and unique patterns on the surface, we can let the pattern recognition of the Qualcomm software track them. As mentioned previously, the natural pattern of the granite stone has good properties for being recognized by this software.

We traced a scale on several flat surfaces of each stone, and photographed each of them perpendicular to the surface. These images were then placed in correct scale on the virtual mesh model of the stone within Unity, using the plugin for Qualcomm Vuforia. When recognizing the image tracker, the software can orient and scale an associated model in relation to the camera on the smartphone, and the three dimensional model is rendered on top of the camera image, appearing as if placed statically in the real-time video. As either the camera or the image tracker, i.e. the surface of the stone, is turned, the 3D model is updated with the new position in space, allowing us to fully explore the 3D position of the model in relation to the physical environment



Figure 14: Augmented mesh model of stone shown on top of existing conglomerate of stones.



Figure 15: A sample stone.

Figure 16: The tracker from the surface of the sample stone.

Figure 17: View through the camera with the sample stone overlaid by the mesh model and following the movement of the stone in free air, as if it is draped over the stone.

3.0. DISCUSSION

Humans have always adapted successfully to their environment. Currently, their development happens in parallel with the advancement of widely adopted information technology. The digital environment shapes the way we think and the way we live. We can draw a parallel to the first permanent human settlements constructed from dry stone, which led to the beginning of civilized life for early societies. Similarly, computational materials like the one proposed in this paper, can lead to a new approach of evolving the digital into a new physical reality.

When using virtually overlaid models correctly positioned in the environment, we are able to both guide and change the next step instantly. The gap between design and construction is being closed, and the design phase does not need to stop as construction commences. But if we are supposed to make these technologies act in an urban setting where actual needs must be met and slightly larger scale modifications are made, we could ask if real time is in fact sufficient or if we may need to forecast and predict near future events and necessities.

There are also other considerations of environmental interest in that we make use of locally available materials, which can significantly reduce the environmental impact of buildings. Currently the use of natural stone presents more disadvantages than the additional cost of fabrication and transport of homogenous materials, although smart use of technologies may change this. 3D reconstruction software has limitations. It may lose track of the camera position if there are not enough features to track in the image. In this case, scanning needs to be restarted because the obtained mesh is broken.

CONCLUSION AND FUTURE WORK

We showed the potential for using mixed reality and closely linked representations in a real-time computational construction process. For this particular computational composite, it turned out that the aspects of non-uniform natural materials was a good way to bind the computation to the matter by using pattern recognition. Natural materials such as granite are comprehended better by visual recognition systems than more conventional modern homogenous materials. We experimented with the variable aspects of a physics engine that was used to compute and augment human construction skills. Future mixed reality architecture applications could make use of computational composites in order to fuse design and construction.

REFERENCES

- Brooks, Rodney A. 1991. "Intelligence without representation." *Artificial intelligence* 47.1: 139-159.
- Rieffel, Marc A. 1995. "Induced representations of C^* algebras", *Advances in Mathematics* 13.2: 176-257.
- Alexander, C. 1964. "The synthesis of form."
- Vallgård, A. and Redström, J. 2007. "Computational composites" *Proceedings of the SIGCHI conference Human factors in computing systems*. ACM.
- Switzers Nursery & Landscaping (2011) https://www.youtube.com/watch?v=owTnhZ_TOx8
- Frey, Carl Benedikt, and Michael A. Osborne. 2013. "The future of employment: how susceptible are jobs to computerization?."
- Abboud, Rana. 2014. "Architecture in an Age of Augmented Reality."

- Thompson, A. 2006. "The Character of a Wall. The changing construction of agricultural walls on the island of Gozo" *Omertaa Journal of applied anthropology*
- Wilson, Michael R. 1980 "Granite types in Sweden." *GFF* 102.2: 167-176.
- Unity, 2014. <http://unity3d.com/unity/download> (The Pro version was not required in our experimentation)
- Unity Extension - Vuforia v3.0, 2014. <https://developer.vuforia.com/resources/sdk/unity>
- Brown, Terence A., et al., 2009. "The complex origins of domesticated crops in the Fertile Crescent." *Trends in Ecology & Evolution* 24.2: 103-109.
- Schmidt, Klaus, 2000. "Göbekli Tepe, southeastern Turkey: A preliminary report on the 1995-1999 excavations." *Paléorient*. 45-54.
- Harris, David R., 1989. "An evolutionary continuum of people-plant interaction." *Foraging and farming: the evolution of plant exploitation*: 11-26.
- Frazer, John, 1995. "An evolutionary architecture."
- Seichter, Hartmut, 2003. "Augmented reality aided design." *International Journal of Architectural Computing* 1.4: 449-460.
- Dorta, Tomas, Gokce Kinayoglu, and Michael Hoffmann, 2014. "Hyve-3D: a new embodied interface for immersive collaborative 3D sketching." *ACM SIGGRAPH 2014 Studio*. ACM.
- Abboud, Rana, 2014. "Architecture in an Age of Augmented Reality."
- Milgram, Paul, and Fumio Kishino, 1994. "A taxonomy of mixed reality visual displays." *IEICE TRANSACTIONS on Information and Systems* 77.12: 1321-1329.
- Tamura, Hideyuki, Hiroyuki Yamamoto, and Akihiro Katayama, 2001. "Mixed reality: Future dreams seen at the border between real and virtual worlds." *Computer Graphics and Applications, IEEE* 21.6: 64-70.
- Niessner, Matthias, et al, 2013. "Real-time 3d reconstruction at scale using voxel hashing." *ACM Transactions on Graphics (TOG)* 32.6: 169.
- Collins, Brian, et al. 1995. "The Dresden Frauenkirche-rebuilding the past." *BAR International Series* 598: 19-19.

Natural building: The viability of straw bale as a sustainable construction material for the future

Arsenio Rodrigues¹

¹Prairie View A&M University, Prairie View, Texas

ABSTRACT: The research paper highlights the importance of the (interconnected) *systems theory* model as one of the most relevant and pertinent approaches toward addressing sustainable construction material-technology for the future. By taking a values-based approach that integrates social and ecological good with health, resource efficiency, and durability, the paper advocates the urgency for future material-technology research to re-examine natural and sustainable building techniques vis-à-vis systems thinking and therefore, a more holistic approach towards design and the building process. In doing so, the paper examines the viability of *straw bale* as a sustainable material-technology for our future construction needs. As evidenced by numerous precedents, straw bale buildings results in energy efficient, durable, and non-toxic structures. Straw bale walls incorporate remarkable thermal, acoustic, fire, and insect resistance properties. In addition, they are characterized by relatively low maintenance, high longevity, improved indoor air quality, and embody intangible aesthetic qualities. Most importantly, they are environmentally responsible and contribute to sustainable development of the built environment. Related to straw bale wall systems, the research paper explores essential concepts related with its building science including, straw stalk, structural system, stud framing, pony wall, wall cavity, and base plaster. In terms of building performance, (of the myriad qualities associated with straw bale) three of its most critical (and perhaps most misunderstood) characteristics are examined - thermal capacity, moisture performance, and fire resistance. Material presented herein, has been largely gleaned from first-hand experience while working with experts on a straw bale structure at Yesterday Design/Build School in Vermont.

KEYWORDS: Sustainability, Natural Building, Straw Bale

INTRODUCTION

The four traditional components – cost, function, aesthetics, and time, typically associated with the architectural design process are now complimented with an essential new concern – *sustainability*. According to the International Institute for Sustainable Development, it should be our aim to meet the needs of the present without compromising the ability of future generations to meet their own needs. The American Institute of Architects defines sustainability as the ability of society to continue functioning into the future without being forced into decline through exhaustion or overloading of the key resources on which the sustainable systems depend. Broadly defined, sustainability vis-à-vis the building industry is therefore not merely an environmental concept, but also a social and economic one – an idea that seeks to judiciously address the effects of buildings on the environment and define limits for consumption of resources, while simultaneously considering the needs of the future. In this regard, rather than encumber the traditional components, sustainable design has provided remarkable environmental benefits while contributing positively to the traditional design process. Arguably, sustainability has fostered and forged *systems thinking* among various participants in the building industry. With systems thinking at its epicenter, one may now expect a more embodied, meaningful, inclusive, and integrative approach related with myriad components of sustainable design including: economic decisions (evidenced in life-cycle and matrix costing); functionality (reflected via the buildings energy use and efficiency); architectural scheduling (observed through the integrated design approach); and design aesthetics-appeal (expressed via the judicious use of related material-technology). This new paradigm of sustainable design implies not only a growing consensus in favor of environment-friendly design, but also a greater holistic approach to building – an all-encompassing model of architecture that centers the designer and its users to an *ecologically sensitive* world-view.

Economic researcher and futurist, Chris Martenson's (2011) analysis of the critical relationship between our economy, energy, and environment clearly demonstrates the pressing need for a more sustainable world-view vis-à-vis the systems theory. Martenson ingeniously makes the thesis that our economy must grow to support a debt-ridden money system that in turn requires compounded growth, but is challenged by an energy system that is limited, and where, both economy and energy are linked to a natural resource world that is rapidly being depleted. A sustainable equilibrium between our economy-energy-environment therefore remains critical to our very survival as a species. In this regard, the sustainable mode of being remains not an option, but rather a dire necessity. Within the context of future building materials and research thereof, the sustainable model therefore, becomes our highest priority – specifically as it relates to our efforts and decisions in addressing the energy-environment duo.

In assessing the viability of a building material for future development, we would be remiss in the first instance, not to examine its ecological underpinnings. Two typologies of analysis (or boundaries) remain pertinent to the ecological impact of a building material (primarily through its energy use and environmental impact). These are: 1) Cradle-to-Gate; and 2) Cradle-to-Grave. The cradle-to-gate analysis more commonly known as *embodied energy* is simply a calculation of the amount of energy consumed to produce a material from raw feedstock extraction through production and manufacturing. By comparison, the cradle-to-grave analysis is a comprehensive measure of all energy used in resource extraction, manufacturing, production, transportation to site, inclusion within a building, and its ultimate disposal (Hammond and Jones 2011). The cradle-to-grave method is obviously much more relevant and pertinent to sustainability in comparison to the cradle-to-gate method. Within the context of sustainability therefore, sourcing of building materials (in terms of local availability and transportation to site) remain critical in the material selection process.

On a yearly basis, the building industry is responsible for contributing 35% of greenhouse gases emitted in North America (Biello 2008). As architects, our decisions regarding selection of building materials have a direct impact to contribution of greenhouse gases. Since, carbon dioxide is the most common heavily produced anthropogenic gas related with the production of building materials, its study related to sustainability warrants attention. It follows that choosing materials with a low carbon footprint has immense potential in reducing the buildup of greenhouse gases in the atmosphere. Production of building materials typically accounts for 13% to 18% of the overall energy consumption of a building – operating the building in terms of heating and cooling during its life span encompasses the remaining (Racusin and McArleton 2012). Life-cycle analysis of building materials in relation to their performance therefore, has the most significant bearing on the ecological impact related with the analysis of carbon footprint of a building. According to International Standard ISO 14040, life-cycle analysis is broadly defined as a compilation and evaluation of the inputs, outputs, and the potential environmental impacts of a product system throughout its life cycle. Further, critical factors considered in the life-cycle include: fossil fuel and non-renewable resource depletion, water use and contamination, global warming potential, and toxic release to air, water, and land. In this regard, minimizing waste (end of life impact) also has substantial ecological implications – particularly in terms of a materials reuse and recycling potential.

Toxins associated with the production, usage and ultimate disposal (or even reuse/recycling) of building materials remains a critical concern to the ecological realm. Similar to cradle-to-grave energy and carbon footprint analysis, the cradle-to-grave toxic footprint remains an important area of inquiry. In this regard, toxicity associated with some building materials has been well established – asbestos, lead, mercury, arsenic, creosote, and ozone depleting CFC's among others. In some cases and to some extent, remediation related with toxicity may be accomplished through judicious reuse and/or recycling of materials. In other cases, and to the general detriment of the environment, post construction use and disposal issues has lead to the wide-spread acceptance of generic building materials that has fostered an out-of-sight, out-of-mind legacy within the building industry. The relentless harnessing and over consumption of energy resources related to high carbon footprint building materials (including life-cycle operation of buildings built with such materials) have lead to negative contributions in terms of our local and greater ecological system. Such anthropogenic consequences related with ecological disturbances are clearly evidenced in oil drilling and mining operations among other resource extraction processes. As a sustainable building material for the future, straw bale clearly remains formidable in terms of its minimal impact to ecological concerns.

1.0. BUILDING SCIENCE

1.1. Straw stalk

Straw refers to the stems of various grasses belonging to the *Poaceae* family, particularly cereal grains such as wheat, rye, rice, barley, etc. Straw remains distinct from hay, in that straw is the woody hollow stalk of the cereal grain plant, while hay is the top of the plant where most of the primary nutrition (grain) is located. While hay is most often used as feed (secondary nutrition) for livestock, straw is generally treated as a waste by-product. Rarely is straw used as livestock feed, on account of its low nutritional value. However, as a component in the sustainable building process, straw remains a highly viable option, particularly on account of its 'waste by-product' nature. Further, straw is readily available in large quantities during the year (specifically during the harvest season) due to its high 'regenerative' ability related to farming. Lastly, straw has diverse uses as a material in wall systems including straw bale, adobe block, and cob among others.

1.2. Structural system

When building with straw bale, three general types of structural systems may be used – load bearing, non-load bearing, and hybrid (combination of load bearing and non-load bearing). The non-load bearing category most commonly includes the post-and-beam system with straw bale infill, stud wall framing with straw bale infill, or a combination thereof. Within the context of sustainability, and in keeping with the theme of viability

of straw bale as a material for the future, this paper explores important facets of the *non-load bearing stud wall framing with straw bale infill*. Primarily because, wood framing provides the structure for the building, which serves to support the roof, thereby allowing the roof to be erected prior to, and provide waterproof protection to the installation of straw bales. This strategy makes straw bale construction viable not only in dry/arid and moderate climates, but also in the extreme cold wet climates of the northeastern United States.

1.3. Stud framing

Lumber used in the construction of stud walls should be locally harvested. Where local sourcing is not possible, the use of green lumber harvested via silvicultural practices and milled by regional sawmills is preferred (Racusin and McArleton 2012). Stud framing (stick framing) in the first instance, is highly predictable in its pattern of layout and also universally accepted by builders on account of its simplicity, repetitive nature and feasibility in terms of time and ease of construction – it is the preferred method of construction due to its affordability and efficiency of production in the field. Regarding sustainable concerns related to wood resource consumption, *value-engineered framing system* (advanced framing technique or optimum value engineering) may be utilized. These techniques involve strategic design decisions to reduce wood usage in framing systems. Further, these sustainable framing strategies are code-compliant, thoroughly detailed and vetted (by National Association of Home Builders and United States Department of Energy) for structural performance, including cost and resource savings in documented field testing.

1.4. Pony wall

In most circumstances, and depending on soil conditions, a slab-on-grade may be used in conjunction with the straw bale wall system. The level difference provided by the slab in relation to grade offers the first level of 'lift' (protection against moisture damage). An additional lift of 12 inches above the slab in the form of a 'pony wall' provides adequate and much needed moisture protection to the base of the wall. Various options pertaining to the materiality of the pony wall are available, including insulated concrete forms, concrete blocks, durisol blocks, faswal blocks, etc. According to Racusin and McArleton (2012), a double-stud pony wall (box framing) blown with cellulose (for insulation) has multiple advantages: it offers the opportunity for various types of interior and exterior wall base finishes (siding, shingles, veneer stone, cement board, stucco, tile, drywall, plaster, wood-board finish, etc.); it offers the opportunity to inset shelving or storage into the pony wall (although R-value of the wall decreases with this feature); it provides ease of installation in terms of electrical cable runs and boxes; and it functions on the interior as a study base for installing a 'toe kick' (base board) which in turn provides protection to the base of the wall, especially when plastered.



Figure 1: Squaring of bales (prior to installation) and beveling of window wall edges with chain saw.

1.5. Wall cavity

Upon successful completion of building design and execution of on-site building components including foundation, framing, and roofing, constructing straw bale walls typically involves three processes: 1) bale preparation; 2) bale installation; and 3) plastering and finishes. Beyond the contextual purview of the paper, but of critical consequence to the actual design of straw bale buildings is a thorough understanding of the actual anatomy of bale units, individually and collectively, within the wall section. Knowing the full thickness of the wall (thickness of straw bales plus thickness of plaster), prior to designing the foundation and overall

footprint of the plan is critical. It is essential to understand that the bales are laid either *on-flat* or *on-edge* and further, notched to accommodate the studs within the wall framing of the building (Fig. 1). An individual straw bale module typically measures 14-inch x 18-inch x 36-inch. These measures remain approximate, as minor deviations in dimensions of the straw bale modules are to be expected. Bales laid along the 14-inch direction are termed *on-edge*, while bales laid along the 18-inch direction are referred to as *on-flat*. Regardless, bales within the wall system typically follow a running bond (staggered seams) pattern for increased wall integrity and will result in a wall thickness (excluding plaster and finishes) of either 14 inches or 18 inches. The specific layout of bale modules (on-edge or on-flat), including the resultant wall thickness are important considerations in the design process – designing to an iteration of the bale module in terms of window heights and other enclosure elements increases construction feasibility.

1.6. Base plaster

Upon successful installation of bales within the framing system, a base coat of plaster is applied to the exposed surface of straw on both sides of the wall. For optimum results pertaining to thermal performance, quality control must be exercised – the plaster coat must be continuous with no breaks or gaps in its plane of application. In this regard, air fins are an important component of the straw bale wall system as they ensure continuity in the plaster coat. Cracks developed (due to the non-rigid substrate nature of straw bale or due to potential shrinking and expansion of framing or other wall components when exposed to liquid or moisture vapor) in the plane of the plaster coat may compromise thermal and moisture performance. Therefore, attention to consistency and proportions of plaster components (water, clay, fiber aggregate, etc.) is essential. The base coat must be flexible such that it inhibits cracking. In this regard, a clay-based plaster (typically one inch thick) is preferred. In terms of performance attributes, a clay-based plaster base offers the greatest advantage in terms of the ‘drying’ component as defined by John Straube (1999). Clay possesses excellent vapor permeability and hydrophilic properties. Clay’s greatest strength (its ability to attract and hold substantially large amounts of water without deformation) also counteracts straw’s greatest weakness (its susceptibility to rot in prolonged presence of elevated moisture levels). Due to the vulnerability of clay to erosive action from precipitation, the application of a hardy but vapor-permeable finish of lime-sand plaster over the coat of clay-based plaster is highly desirable – the finish offers tremendous durability to the wall.

The base coat of plaster for a straw bale wall system is mainly composed of three constituents: aggregate (sand, gravel, fine sand, and stone powder); binder (lime, clay, gypsum, stucco), and fiber (chopped straw, animal hair, cellulose, and plant material such as cattail, hemp). An additional component in the form of additives is also added occasionally based on subtle characteristics desired for the coat. Aggregates make up the bulk (in terms of volume) of the mix, while binders provide the gluing action in the mix. While aggregate and binder form the basic structural base of the plaster, fiber provides tensile strength and functions within the mix to reduce or eliminate cracking. According to Weismann and Bryce (2008), the plaster mix must be composed approximately of 85% aggregate. Racusin and McArleton (2012), based on substantial experience in the field related with straw bale buildings, advice on approximately 30% of fiber (or lower), and 2% to 15% of additives (if used) within the mix. Further, they suggest a binder-to-aggregate ratio (range) of 1:2 to 1:4. For optimum results, field tests must be conducted to gauge the consistency of the plaster mix primarily in terms of its workability, strength, cracking potential, and texture.

2.0. BUILDING PERFORMANCE

2.1. Thermal capability

Given that the largest amount of embodied carbon comes from energy consumption related with the thermal performance and operation of the building during its life span, the primary goal of wall systems is that of minimizing heat loss or gain. As has been thoroughly documented in field testing, the two primary avenues of heat loss or gain are convective air infiltration and conduction through the building envelope. Related to sustainable design and therefore energy performance, the main criteria in the selection of a wall system, therefore remain its insulative qualities (R-value) to counter heat loss or gain, and efficient detailing of the wall system to counter air infiltration. The fundamental component of thermal performance strategy of a building therefore is the integrity of the thermal envelope of the building, in that the following two elements are typically desired: 1) a thicker plane of insulation (that reduces conductive losses); and 2) a continuous thin plane of air barrier (that reduces convective losses).

Thermal and moisture performance of straw bale wall systems are intimately related. In the first instance, straw bale as a wall system relies on vapor permeability for its thermal performance – the wall assembly is designed to allow drying toward the interior and exterior of the building. Vapor barriers are therefore functionally redundant in a straw bale wall system. Rather, materials that allow vapor to permeate, diffuse, and evaporate through the wall membrane are preferred. In the straw bale wall system, the base plaster (on both sides of the wall) functions as the essential vapor permeable air barrier. In this regard, and as has been

evidenced in field testing at Oak Ridge National Laboratory in 2004, the integration of vapor permeable air barriers on both sides of the wall assembly maximizes thermal performance while enhancing moisture mitigation. Results from the study demonstrated a very high net of R-33 for a three-string bale on the flat. Complimenting its high net insulative qualities, a straw bale wall system inherently eliminates heat loss or gain that would otherwise have occurred through the phenomenon of thermal bridging in a conventional 2 x 6 stud wall framed 16" on center with typical fiberglass batts. In this regard, the straw bale wall system essentially decouples the framing from running through the entire thickness of the wall, thereby eliminating conductive heat loss or gain enabled via the phenomenon of thermal bridging.



Figure 2: Application of air-fins, flashing, and metal lath at critical transitory locations along the wall plane.

Field testing related to thermal characteristics of seven straw bale homes in Northeast (Vermont and New York) by Building Performance Services LLP in 2011 demonstrated that in every case, the largest incidents of air infiltration occurred in the non-straw-bale components of the building, such as roof assemblies. Further, the study revealed that air fins (Fig. 2) functioned very effectively at controlling heat loss and preserving the integrity of the air barrier in transition from plaster to wood elements, both along the roof-to-wall and foundation-to-wall connections. What remains critical along these connections is quality control related to the air fins – proper sealing between two separate pieces of air fins, including proper sealing between the air fins and framing. In this context, the thermal performance of straw bale walls is largely derived due to its ‘mass’ characteristics. The phenomenon of thermal lag in relation to a straw bale wall has been field tested to be approximately twelve hours (King 2006). The heating/cooling cycle of a straw bale wall remains directly and therefore advantageously opposite the diurnal cycle. This ‘mass effect’ further improves thermal performance of straw bale walls by a factor of 1.5 to 3 times its original R-value rating and is described as ‘dynamic benefit for massive systems’ (Kosney 1999). This phenomenon, although largely pertinent to the southwestern United States (i.e., regions with a high diurnal temperature swing), is still relevant in cold climates as demonstrated in field tests conducted at Oak Ridge National Laboratory.

2.2. Moisture performance

Moisture control strategies for straw bale buildings begin prior to construction. In the first instance, bales sourced from suppliers must be dry. Further, the bales need to remain dry during transportation from source to site and then again, when stored on site, requiring considerable precaution in scheduling and logistical support (Racusin and McArleton 2012). It is for this reason that straw bale buildings favor construction and waterproofing of the roof assembly first, prior to installation of the wall system itself. Water penetration via capillary action at the base of the straw bale wall system (connection with concrete foundation/slab) remains an area that requires careful consideration. An efficient solution to this problem is to isolate the base of the straw bale wall system via toe-ups in conjunction with a capillary break (water proofing membrane). In this regard again, stick framing remains advantageous in conjunction with straw bale wall systems.

Precipitation in the form of rain and snow present the biggest challenge to straw bale wall systems in terms of water driven damage. In this regard, flashing and material connection details require considerable attention. Further, the erosive action of water on plastered surfaces, primarily through wind-driven rain and splash-back effect near the base of the wall system must be considered. Design features such as generous roof overhangs, roof gutters, water-dispensing ground cover, and bottom-of-wall protection features provide effective counter measures to moisture damage. According to Racusin and McArleton (2012) a minimum 2-foot overhang is required for a two-storey building, while a three-storey building requires a 3-foot minimum overhang. Similarly, incorporating an additional lift of 18 to 24 inches above grade (pony wall), provides

adequate protection for the plaster at the base of the wall system. This raised box functions not only to protect against splash-back, but also provides the added opportunity for electrical, plumbing or other service runs. This feature also prevents moisture accumulation at the base of the wall system that would otherwise have occurred via capillary action through the concrete foundation/slab.

As evidenced in thermal performance, the moisture performance of the straw bale wall system in terms of vapor diffusion remains highly advantageous. In the straw bale wall system (i.e., vapor-permeable building system), moisture build-up in the form of vapor inside the building (generated via cooking, washing, respiration, etc.) is allowed to diffuse through the wall membrane to the outside depending on the direction of the vapor drive. According to Racusin and McArleton (2012), diffusion-borne moisture is in and of itself insufficient to cause moisture damage to wall systems – diffusion's potential as a drying mechanism outweighs its liability as a moisture vector. Within this context, note that conventional vapor barriers strive to reduce or halt vapor diffusion altogether. Of importance is the highly practical strategy and well-researched model of 'moisture balance' as outlined by John Straube (1999) in *Design of Straw Bale Buildings*. The model highlights an efficient moisture control strategy via optimum balance of the following three elements – wetting, drying, and safe storage of moisture within the building assembly. To elaborate, short-term moisture accumulation in a building will not lead to long-term problems, as long as the rate (length of time) of wetting does not exceed the rate of drying by more than the safe storage capacity of the building.



Figure 3: Spraying clay slip (drywall texture gun and air compressor) and two-hand trowel plaster method.

Base plaster on both sides of the straw bale wall helps in the creation of climatically responsive and adaptive structures – being hygroscopic in nature, the base plaster helps moderate changes in indoor humidity, with the result being a more uniform and comfortable indoor environment. The relevance of a clay-based plaster base (Fig. 3) to straw bale wall systems cannot be understated – the clay seeks to actively draw moisture to itself, thus keeping it away from the straw. Superior functional attributes of clay as a base plaster material have been discovered in 500-plus year old cob wall in Europe, where straw inside the clay was perfectly preserved and mummified (Lacinski and Bergeron 2000). Owing to its high vapor permeability, clay allows the moisture to diffuse into the air. It is important to note that in relation to plaster-type, a cement-based plaster is in fact detrimental to straw bale wall systems – cement possesses a very low vapor-permeability coefficient which leads to trapping of water within the wall system, rather than enabling transpiration of moisture into the air. In this regard, to encourage diffusive drying to the exterior (encourage vapor drive from indoor towards the outdoor), the exterior base plaster should be made more permeable than the interior base plaster, which is simply achieved by adding additional coats of plaster to the interior. Through field testing, Racusin and McArleton (2012) have verified that moisture content threshold for rot and decay related to straw remains approximately 30% - comfortably higher when compared to the range of seasonal fluctuation and incidental wetting that occurs in northeastern United States. In addition, due to the large pore sizes of the tubular stalks, straw reduces capillarity, with the result that localized water exposure on the exterior face of the bales is less likely to wick the liquid into the wall cavity.

Moisture testing in straw bale wall systems conducted by Racusin and McArleton, repeatedly evidence that elevated moisture content percentages drop off rapidly moving from the exterior into the center of the wall

system. Through field tests conducted over a ten year period using a Delmhorst hay probe moisture meter, Racusin and McArleton reported a seasonal moisture content range of 5% to 14% for straw bale buildings in the Northeast region. Field testing conducted by Building Performance Services LLP in 2011 showed moisture contents of 12% to 15% for one year old straw bale buildings, even when surface and pin scans and visual inspection of the plaster registered near-saturation levels. Further, the test corroborated that moisture content readings in the center and interior edge of the wall systems were still considerably lower, demonstrating that the vapor drive was directed towards the exterior and that moisture was not evenly dispersed throughout the entire thickness of the wall, but rather more localized towards the exterior. Based on the 'wetting' potential of its assembly, straw bale wall systems are therefore, intentionally designed to store substantial amounts of moisture for short periods of time. This approach acknowledges and embraces the pragmatic reality that constructing absolute water proof walls on site remains verifiably cumbersome, if not impossible. Straw bale wall systems are typically criticized by builders for problems related to rotting caused by moisture. However, such patterns of concern remain typically attributed to poor design, poor detailing, poor execution, and ultimately poor comprehension of how moisture works in buildings.

2.3. Fire resistance

Plastered straw bale wall systems possess superior fire resistance qualities in comparison to standard fiberglass-insulated stud walls. Unplastered straw bales within the wall assembly, when exposed to fire, begin to smolder in a low-oxygen state, once the exterior layer of straw has charred. This occurs due to dramatically low levels of oxygen reaching the inner cavity of the wall upon combustion of the outer layers. In this regard, unplastered straw bales possess fire-resistance capabilities similar to those of heavy timber. In 2007, Ecological Building Network commissioned formal American Society of Testing and Materials International fire-rating testing on two straw bale wall systems: a two-string flat-laid straw bale wall plastered with two ½-inch earth plaster coats; and a two-string edge-laid straw bale wall plastered with two ½-inch lime-cement coats. In both cases, the wall samples (10 feet x 10 feet) were subjected to a 1700°F blast furnace for a prescribed amount of time to test their fire resistance capabilities. Results of the test were as follows: the earth-plastered straw bale wall system successfully passed a 1-hour fire resistance test, while the lime-cement plastered wall successfully passed a 2-hour fire resistance test. In both cases, only 3-4 inches of the depth of the straw bale wall exposed to the furnace was observed to be charred. In the final analysis, both wall systems successfully passed code-recognized testing.

CONCLUSION

The importance of sustainability vis-à-vis the *systems theory* model to address architectural research related with future material-technology cannot be understated. Within the context of systems thinking, architectural research related to future building materials must remain meaningfully relevant to sustainability and further, critically pertinent the economy-energy-environment model. In addition to merely addressing aesthetics concerns, researchers need to study future building materials vis-à-vis their local availability, affordability, ecological impact and social context, among a slew of other building science and performance concerns. In this regard, with its roots in ancient building techniques, modern natural building in the form of straw bale is currently experiencing its re-emergence as a valuable design-construction strategy (Fig. 4).



Figure 4: Straw bale building built in Waitsfield, Vermont.

Founded on a values-based approach (that integrates social and ecological good with health, resource efficiency, performance, and durability), straw bale buildings offer tremendous benefits. What remains critical to its success though, is quality control in construction and attention to detailing in design. Further research is required and may help dispel myths related to perceived drawbacks, specifically those related to its moisture performance and durability. Although largely unexplored as a construction material-technique, it arguably remains one of the most viable options for sustainable, ecologically sensitive, and aesthetically beautiful wall systems. When detailed meticulously, straw bale wall systems possess stellar performance characteristics in terms of R-value, durability, moisture and fire resistance, including interior air quality and comfort. Further, it successfully meets current stringent performance standards expected by the building industry. It is for this reason that straw bale construction merits a substantive and legitimate place in the lexicon of performance-oriented building materials, specifically in relation to the sustainable mode of being. In the final analysis, straw bale offers a connection to ancient ways of building, – one that is time-tested, timeless, and one that has the potential of exceeding expectations as a sustainable material-technology for the future.

REFERENCES

- American Institute of Architects. n.d. *Continuing Education System: Sustainable Design*.
<http://www.aia.org/education/ces/AIAB089084>.
- Biello, David. 2008. *Green Buildings May be Cheapest Way to Slow Global Warming*. *Scientific American*, March 17. <http://www.scientificamerican.com/green-buildings-may-be-cheapest-way-to-slow-global-warming>.
- Building Performance Services LLC. 2011. *Thermal Characteristics of Selected Straw Bale Homes*. *The Natural Building Companion*. White River Junction, Vermont: Chelsea Green Publishing, pp. 408-409.
- Ecological Building Network. 2007. *Fire Resistance Test of a Non-load Bearing Straw Bale Wall*.
http://www.ecobuildnetwork.org/images/stories/ebnet_pdfs/Non-Bearing_Clay_Wall.pdf.
- Hammond, Geoff and Jones, Craig. 2011. *Inventory of Carbon and Energy (ICE)*, ver. 2.0. Sustainable Energy Research Team (SERT). Bath, UK: University of Bath. <http://www.bath.ac.uk/mech-eng/sert/>.
- International Institute for Sustainable Development. n.d. "What is Sustainable Development?"
<https://www.iisd.org/sd/>.
- International Organization for Standardization. n.d. "Environmental Management - Life Cycle Assessment."
http://www.iso.org/iso/catalogue_detail%3Fcsnumber%3D37456.
- King, Bruce. 2006. *Design of Straw Bale Buildings*. San Rafael, CA: Green Building Press, pp.185-194.
- Kosney, Jan. 1999. *New Values for High Mass Walls*. *Home Energy*, September-October.
<http://www.homeenergy.org/archive/hem.dis.anl.gov/eehem/99/990912.html>.
- Lacinski, Paul and Bergeron, Michel. 2000. *Serious Straw Bale: A Guide to Construction in All Climates*. White River Junction, Vermont: Chelsea Green Publishing.
- Martenson, Chris. 2011. *The Crash Course: The Unsustainable Future of our Economy, Energy, and Environment*. Hoboken, New Jersey: John Wiley and Sons, Inc.
- Oak Ridge National Laboratory. 2004. *A New Whole Wall R-Value Calculator*.
<http://www.ornl.gov/sci/roofs+walls/NewRValue.pdf>.
- Racusin, Jacob and McArleton, Ace. 2012. *The Natural Building Companion: A Comprehensive Guide to Integrative Design and Construction*. White River Junction, Vermont: Chelsea Green Publishing.
- Straube, John. 1999. *Moisture Properties of Plaster and Stucco for Straw Bale Buildings*. *University of Waterloo Archives*. http://homegrownhome.co.uk/pdfs/Straube_Moisture_Tests.pdf.
- Weismann, Adam and Bryce, Katy. 2008. *Using Natural Finishes*. Totnes, Devon, UK: Green Books.

Surveying stereotomy: Investigations in arches, vaults and digital stone masonry

Shayani Fernando¹, Rob Saunders¹, Simon Weir¹

¹University of Sydney, Sydney, Australia

ABSTRACT: The art of fabricating, making, crafting and the traditional sense of the stone mason has been diminishing due to dramatic changes in technology. The path of increasing complexity in formal stereotomy is causing the increased use of structural analysis influencing current design. This paper will look into past methods of stereotomic stone masonry construction techniques, and how new practitioners are utilizing stereotomy. Through case studies and historical precedents, methods in stereotomic analysis will be investigated, focusing on the machine generation of the arch.

The arch in its simplest form is the fundamental structure for spanning in unreinforced masonry and has the potential to be combined into many variations. The arch produces a line of thrust which is a theoretical line that represents the path of compressive forces through the structure; which can be used to design and analyze vaulted structures in masonry. The paper traces the change in the meaning of stereotomy, from geometric form finding to advanced static, construction analysis and production. It will survey past, present and emerging practitioners and investigate stereotomic methodology in the creation of vaulted spaces.

KEYWORDS: Stereotomy, Voussoir geometry, Stone Arches, Vaulting systems, Computational Craft

INTRODUCTION

The renewed interest in stereotomy relating to the construction of freeform and vaulted spaces is due to emerging Computer Aided Design and manufacturing technologies, as well as the revival of interest in stone as a construction material due to its ecological properties. As José Carlos Palacios states, after the peak of stereotomy research in the nineteenth century, the advancement of the industrial revolution brought the rise of new building techniques and materials which were primarily structural steel construction. The modern aesthetic of the time further diminished the place of traditional stonework and ornamentation. Across these decades,

stereotomy collapses and falls into oblivion; the massive masonries of traditional architecture succumb to give way to a new architecture based on a structural set up never imagined before. Nevertheless, there is still some hope. New geometrical skills gave way to new developments in stereotomy. Digital monitoring allows expansion of the limits of geometry. (Palacios 2008)

The return of stereotomy is largely due to the improvement of computational tools, since these tools offer a pathway to continue the stalled tradition of stone architecture. 'Computer graphics enable architects to explore sophisticated forms, while subjecting them to static analysis for safety' (Etlin, Fallacara and Tamborero 2008)¹.

The increased ability to analyze the line of thrust in an arch or vault is contributing to the renewed interest. This paper will cross examine case studies of two practitioners. The work of Professor Mark Burry in the restoration and extension of the Basilica i Temple Expiatori de la Sagrada Familia in Barcelona, Spain, involves various "stereotomic techniques in the construction of doubly curved surfaces for the stone work" (Burry 2006). Another practitioner Philippe Block from the Block research group at the ETH in Zurich is investigating digital stereotomy in terms of voussoir geometry for freeform masonry vaults informed by fabrication and structural constraints (Block 2011).

1.0 STEREOTOMY DEFINED

The term stereotomy can be simply described as the art of cutting solids. In relation to architectural construction, it is a set of geometric instructions and techniques of drawing and cutting blocks of stone for their assembly into complex structures. It has its origins as a French term combining two Greek words meaning 'stereos'(solid) and 'tomy'(cut).² The earliest and most influential texts on cutting geometrical solids are Euclid's 3rd Century BC texts³. Although there is no unambiguous literary evidence for theorizations of stereotomy between the Classical eras and seventeenth century France, Euclid's works were probably the core texts for the practice of stone masonry. Giuseppe Fallacara suggests that the French term has its origin in Philibert de L'Orme's 1567 treatise on architecture.⁴ Although Fallacara does not suggest "a direct geometrical connection between Euclid and de L'Orme", rather, that L'Orme had an interest in "Euclid's work, considering it a very high digest of methodological rigor." (Fallacara, *Digital Stereotomy and Topological Transformations: Reasoning about Shape Building* 2006.) Fallacara hypothesizes that the birth and evolution of projective geometry came from Euclidean geometry speculated by de L'Orme; describing it as a 'methodically setting' according to Euclidean logic. It is interesting to find that Robin Evans categorizes the two geometries as "Platonic and projective rather than Euclidean and Vitruvian" (Evans 2000).

According to Danila Aita, stereotomy, through geometrical principles "allows one to visualise a tridimensional object by means of a bidimensional reproduction... [and] each of the voussoirs." (Aita 2003) Sakarovitch in his paper, 'Stereotomy, a multifaceted technique' describes stereotomy as "the art of drawing the shapes to be given to stones (and bricks) for future assembly" (Sakarovitch 2003) which echoes the French expression 'art du tait', or art of line drawing. The basis for stone cutting was an orthographic projection called the 'tait'.⁵ (Evans 2000) A tait can be defined as layout drawings used to enable for precise cutting of masonry blocks into complex architectural forms. There is an intriguing inconsistency here, several versions of the phrase appear, other than Evan's "tait", there is 'traint' (Block 2009) and 'trait' (Fallacara 2006).

Another approach to stereotomy is the one of Girard Desargues in 1640 who published a unique rule to try to solve the problems of stereotomy. This method presents an important graphical development where Desargues presented a global image through a central perspective of the architectonic model that he wanted to study.

In this sense, Desargues approach was in some way didactical and epistemological, focused on describing a methodology, clearly in contrast to the previous treatises, which described stone cutting work from a geometrical point of view. (Rodriguez, Andres and Alvarez 2011)

Both Sakarovitch and Evans state that stereotomy is a combination of relationships to the history of architecture, masonic geometry, the geometry of the mathematician, studies in the field of mechanics, and the history of crafts and their emergence. (Sakarovitch 2003, Evans 2000)

Whilst Sakarovitch argues that 'statics' is responsible as the fundamental design principle for building stone arches; Aita is quite pertinent on the geometrical problems in finding solutions to the design of arches.

In antiquity, the arch was considered as a pre-eminent example of geometrical perfection, containing in itself a principle of static perfection: the common conviction was that geometry, not statics, could provide the safest proportions for designing arches. (Aita 2003)

According to Giuseppe Fallacara stereotomy is where "specific geometrical rules and correspondences set the relationship between system and part."(Fallacara 2006.) This implies a parametric approach to design where sets of relationships are defined between components and their assemblage. These parameters are employed by the practitioner based on their requirements. Sakarovitch subsequently explains his preference for Claude Perrault's definition of "the art of using the weight of stone against itself so as to hold it up thanks to the very weight that pulls it down" (Sakarovitch 2003).

This sequence of definitions implies the arch as the generator of stereotomy which gives a "historical depth of 23 or 24 centuries" (Sakarovitch 2003). Stereotomy began as a methodology and descriptive geometry, over centuries it acquired meanings associated with, statics and mechanics. Its continued evolution due to time, technological innovations and context depicts the mutable nature of the term itself.

1.1. Increasing complexity of stereotomy

There is a correlation between the development of stereotomy and advancement of construction tools. Constructing particular shapes and vaults is partly reliant to stone cutting techniques such as half squaring, repointing, squaring and cutting with a template. The cutting method is also dependent on the stone material and size, in relation to finding stability compared to that obtained using larger stones to the smaller ones. Another issue is the fact that stone is characterized by a high resistance to compression and low resistance to traction and bending. As such ancient temples used a maximum distance of 4-5 metres between the axes of columns.

Aita explains the 3 archaic cutting methods which require no preparatory trace. These include cutting *par ravalement* where the stones are cut when they are placed in the vault; “cutting *a la demande* where each stone is hewn for subsequent retouching” (Aita 2003). And the 3rd method cutting *par equarrissement* (also known as *derobement*), “consists of cutting the stone without the help of the panneaux, using the height and depths delimiting the voussior to be made.” (Aita 2003)

A construction technique called the *encorbellement* method was developed to get over larger inter axis spaces and coverings. (Figure 1). This method consists in using overhanging (corbelled) stones, with the beds always being horizontal. This was prevalent in works dating back to the 13th century of Mycenaean architecture, as well as from the Etruscans of the 7th to 2nd Century BC, “who frequently used corbelling to cover funeral chambers and to make arches.” (Aita 2003) The encorbelled face could then be cut in-situ, using the technique Aita named, *par ravalement*.

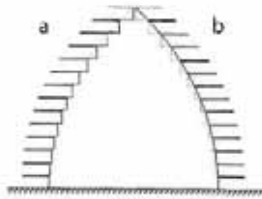

Figure 1: a) The *Encorbellement* method. b) Method of cutting *par ravalement* Source: (Aita 2003)

1.2. Stereotomy and Voussoir Geometry

In the historical record the segmented arch and the tunnel vault (also known as a barrel vault) first appear as brick constructions in the 3rd millennium BC in regions where there was a shortage of wood, such as Mesopotamia and the valley of the Nile. Stereotomy. *a la demande*, stone cutting developed with the introduction of the *voussoir*. A *voussoir* is defined as a “wedge shaped stone with two oblique faces by means of which it rests on the adjacent voussoirs, laterally transferring the vertical forces due to its own weight and any other loads.” (Aita 2003) Figure 2 reveals a segmented arch composed of four voussoirs either side of a central key stone.⁶



Figure 2: Segmented arch with defined terms: (Purchase 1904)

The problem faced by medieval builders in the realization of vaults was how to cut the voussoirs constituting a structure. Aita implies that the medieval builders answered the structural questions, coincidentally by solving the geometrical problems: symmetry, stability, material resistance and equilibrium of forces. Jacques Heymen, in 'The Stone Skeleton' describing the design requirements for masonry arches, "failure of a masonry structure will occur when the line of thrust can no longer be contained within the stonework." (Heyman 1966) He then describes in terms of design principles certain assumptions which can be made about the material. These include:

- (1) Stone has no tensile strength (assuming that the arch voussoirs are laid dry or with very little mortar).
- (2) The compressive strength of stone is effectively infinite.
- (3) Sliding of one stone upon another cannot occur. It implies that wherever there is a weak plane, for example between voussoirs, the line of thrust should not depart too far from normality to that plane.

What shapes can a stable arch take? The arch produces a line of thrust which can be used to design and analyze vaulted structures in masonry.

The structural action of complex vaults and domes can be understood by analyzing them as a series of two-dimensional arches contained within these shapes. When analyzed this way, the additional structural integrity resulting from the three-dimensional aspect of vaults and domes provides a further margin of safety. (J. A. Ochsendorf 2012)

Figure 3 reveals a simple thrust line analysis of the arch of Taq-I Kisra (540AD Ctesiphon, Iraq) that was used to estimate the magnitude of the internal compressive forces and to demonstrate its safety.

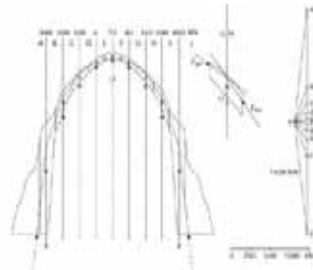

Figure 3: Thrust lines for Taq-I Kisra arch (image: Joseph Dahmen 2012).

1.3. Gaudi's catenary chain models

Spanish Catalan architect Antoni Gaudi(1852-1926) created hanging chain models as extraordinary formal and structural design models based on catenary curvature. The word catenary is derived from the Latin word catena, which means "chain". It is based on the delicate balance of opposing forces that gives rise to a certain amount of structural stability. A chain suspended from two points will always try to form a catenary. This happens because the chain is hung in a state known as "pure tension," so it will always adjust itself to find this balanced state. Only tension forces can exist in the hanging chain; inverting the shape into an arch reverses those into pure compression forces. All that compression force acts along the curve and never at right angles to it. The connecting faces of voussoirs in catenary arches are approximately, but never precisely, normal to the line of thrust. This makes the inverted catenary very stable, particularly for spanning a horizontal distance. For example Gaudi made a famous scale model of the loads and thrusts involved in the structure of his building, as shown in Figure 4. He hung cords in loops to correspond upside down to the placement and shapes of piers and arches of the vault. The catenary curves of the hanging cords were then distorted into funicular polygons by attaching weights shown in the drawing by Gaudi's assistant Juan Rubio. Using hanging chain models as a graphic analysis tool to investigate structural integrity of arched and vaulted spaces was an effective communicative tool in form finding.

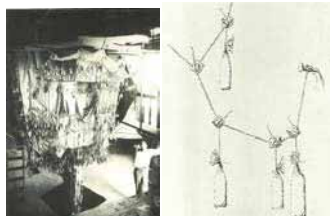

Figure 4: Left: Colonia Guell church, exterior view of Gaudi's funicular model of the church as it hung in the workshop Source: (George R. Collins 1983)Right: Drawing of Funicular model by Gaudi's assistant in structural matters, Juan Rubio Source: (George R. Collins 1983)

2.0. DIGITAL STEREOTOMY

The renewed interest in the construction of freeform and vaulted spaces is due to emerging Computer Aided Design and manufacturing technologies, as well as the revival of interest in stone as a construction material. Although there are other renowned practitioners⁷ which can be studied such as Guiseppe Fallacara's work on "digital stereotomy showing computational modeling techniques when applied on classical stereotomy studies" (Fallacara,2006); two current practitioners Professor Mark Burry and the Block Research group will be examined in this paper for their use of stereotomic principles.

2.1. Burry's reworking of Gaudi's models for the church of Sagrada familia

The Sagrada Familia in Barcelona, Spain, began as a gothic cathedral in 1882 and taken over by Antoni Gaudi in 1883 who worked on the project until his death in 1926. He was perhaps one of the most enigmatic architects in history. Born into a family of metal workers he grew up with a passionate curiosity about nature. Despite the fact that he was a Catalan at a time of great resistance to absorption into Spanish culture, he was regarded as a master craftsman, reminiscent of a medieval artisan. Gaudi's extraordinary working methods have kept the Sagrada Familia not only an architectural icon but also a continuous piece of scholarship⁸. At the time of the Spanish civil war during the 1930s, "the church was raided, the drawings burnt and plaster models smashed." (Burry 2006) Gaudi primarily relied on models rather than drawings to convey his design and construction intent; therefore the models were carefully restored in subsequent decades.



Figure 5: Left: Sagrada Familia Church in context from South East. Source: (Burry 2006) Right: North East View 2009 (Weir 2009)

While classical and medieval arches were based mainly on circular arcs, Gaudi based his geometry on hyperboloids, paraboloids, and hyperbolic paraboloids which closely resembles catenary curvature tracing the arch's line of thrust. The geometrical problems of working with hyperboloids, paraboloids, and hyperbolic paraboloids are not covered in Euclid's work. This means that most masons were probably unprepared to produce these shapes and that the graphical technique for the tait was insufficient for the task which explains why Gaudi worked with models. As the work undertaken today is the effective reverse engineering of Gaudi's models, a graphic technique was developed by his successors. Burry states,

Such graphic techniques were the tools of the stereotomers of the past but the graphic technique for the intersection, for example between a sphere and cone, could not be adapted for the intersection between a circular and elliptical hyperboloid inclined differently with respect to the datum plane. (Burry 1993)

Burry further explained that the benefits of computational models are the ready application of such tools to diverse aspects of the construction process: automated manufacture, calculation of volume and mass of the irregular shaped pieces, and the calculation of the centre of gravity to facilitate the correctly orientated hoisting of the heavy masonry pieces. It is a combination of a surface and solid modelling facility which is now making a significant impact on the working method. As software solid modelling is conceptually distinct from any other drafting packages is more likely to be used by architects. It replicates the plaster model-makers methodology almost exactly. Computational modeling also enables an opportunity to work in a 'parametric' rather than 'explicit' environment. This is where the object can be described as a series of relationships to which dimensional values can be given later and changed at will. "This facility elevates the tool from working slavishly to a known intention to working more intuitively with the designer's considerations."(Burry 1993) The models produced on the screen from these software programs can then be used to drive saws or mills and fashion either a model, a prototype, mold or finally the finished article.

2.2. Block research group - Stone Vault Pavilion

Philippe Block with the Block Research group has been researching masonry modelling and fabrication techniques for many years. The Stone Vault Pavilion is part of a research project in the advancement of freeform masonry construction. This project was a collaboration with the Texas based company Escobedo Construction and Prof. John Ochsendorf, MIT. By combining the ETH / MIT team's expertise in three dimensional equilibrium of complex structures in unreinforced masonry and Escobedo Construction's expertise in fabrication and construction of stone buildings, a prototype project of a state of the art stone vaulted pavilion was developed.

The vault was designed using Thrust Network Analysis, a new graphical form finding tool for exploring three dimensional compression only shapes. This vault prototype serves to learn what is needed to construct new stone forms out of complex stone cut pieces.(Block 2014)

This is shown in Figure 6 with the 3D model showing the load paths and capacity of structural loads, thus revealing the model used as a structural analysis tool. Figure 5 reveals the finished scaled model of the stone vault pavilion.⁹ This project highlights the impact in which current and emerging trends in digital design and fabrication can produce complex geometries using natural materials.

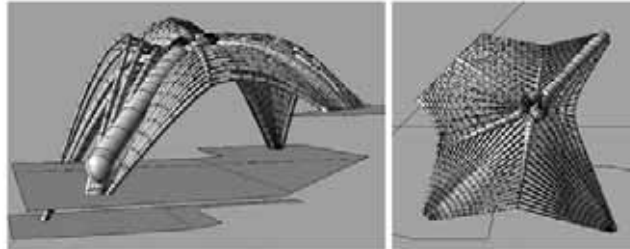

Figure 6: Stone Vault Pavilion 3D model. Source (Block 2009)



Figure 7: Stone Vault Pavilion. Source (Block 2009)

Block's research highlights the trend towards new types of stone vaults with new form finding methods that integrates formal geometry with structural analysis. The CNC process also accelerates the precise procedure of cutting complex forms.

Except for the new challenges related to 'geometrical' complexity, the building industry is also facing environmental constraints. 'Freeform' is no longer accepted at any cost; efficiency of material use is a key consideration to embrace today's economical and ecological demands. (Block 2011)

Analysis tools such as Thrust Network Analysis was developed by Philippe Block as a methodology which finds possible funicular solutions under gravitational loading within a defined envelope. Adopting similar advantages of techniques such as graphic statics in a three dimensional environment, "using projective geometry, duality theory and linear optimization." (Block 2009) These computational techniques not only increase the complexity in graphic analysis but also increases the possibility of more complex stereotomic techniques adopted for more varied vault designs.

CONCLUSION

This paper presents a summary of stereotomy from its origins in the ancient writings of Euclid to the current work Burry and Block. We observed a progressive increase in the complexity of stereotomy from formal, geometric description to increasingly accurate methods of structural analysis. After the demise of stereotomy in the nineteenth century, the next significant step was in the stereotomic innovations of Gaudi and later by his successors, Burry and Block. This approach sought more efficient structural solutions requiring more complex geometries than those found in Euclid, aimed at more closely aligning form with static forces.

Most recently, stereotomy's applicability in new fabrication methods is fuelling a revival of stereotomy. Increasing economic and ecological constraints present a positive argument to reimagine the value of the ancient craft in stone masonry. As demonstrated in the studies of Gaudi, Burry and Block, developments in stereotomy afforded advances in architectural form. As new construction materials and methods for producing vaulted spaces emerge, stereotomy will be continuously redeployed to respond to these new conditions.

REFERENCES

- Aita, Danila. 2003. "Between geometry and mechanics: A re-examination of the principles of stereotomy from a statical point of view." *Proceedings of the First International congress on Construction History*. Madrid.
- Block, Philippe. 2009 "Thrust Network Analysis: Exploring Three Dimensional Equilibrium." MIT. http://web.mit.edu/masonry/papers/Block_PhD_2009.pdf (accessed 2015).
- Block, Philippe. 2009 *Block Research Group*. <http://block.arch.ethz.ch/brg/research/project/stone-vault-pavilion>. (accessed June 2014).
- Burry Mark, Burry Jane. 2006 "Gaudi and CAD." *ITcon Vol 11*, February: 437.
- Burry, Mark. 1993. *Antoni Gaudi, Expiatory Church of the Sagrada Familia Barcelona 1882-*. London: Phaidon Press.
- Carlos, Jose. 2008 "Stereotomy: Acrobatic Stone Vaulting Past and Future." In *Plaited Stereotomy, Stone Vaults for the Modern World*, by Richard Etlin, Giuseppe Fallacara and Luc Tamborero, 12-13. Rome: R. Etlin, G. Fallacara, L. Tamborero.
- Etlin, Richard, Giuseppe Fallacara, and Luc Tamborero. 2008. "Stereotomy, Acrobatic Stone Vaulting Past and Future." In *Plaited Stereotomy; Stone Vaults for the modern world*, by Giuseppe Fallacara, 17. Rome: R. Etlin, G. Fallacara, L. Tamborero.
- Evans, Robin. 2000. *The Projective Cast*. London, England: MIT Press.
- Fallacara, Giuseppe. 2006. "Digital Stereotomy and Topological Transformations: Reasoning about Shape Building." In *Fallacara-libre_Digital stone Masonry Vol. 1*, 1075.
- Fallacara, Giuseppe. 2009 "Toward a Stereotomic Design: Experimental Constructions and Didactic Experiences." *Proceedings of the Third International Congress on Construction History*. Cottbus. 553-560.
- George R. Collins, Juan Bassegoda Nonell. 1983. *The Designs and Drawings of Antonio Gaudi*. New Jersey: Princeton University Press.
- Heyman, Jacques. 1966. "The Stone Skeleton." *Solid Structures*. Great Britain: Pergamon Press LTD, Vol. 2, pp. 249 to 279.
- J. A. Ochsendorf, J. F. D. Dahmen. 2012. "Earth masonry structures: arches." In *Modern Earth Buildings*, 427-459. London: Woodhead Publishing.
- Philippe Block, Matthais Rippmann. 2011. "Digital Stereotomy: Voussoir geometry for freeform masonry-like vaults informed by structural and fabrication constraints." *Block Research Group*. <http://block.arch.ethz.ch/brg/publications/234> (accessed June 2014).
- Purchase, William R. 1904. *Practical Masonry: A Guide to the Art of Stone Cutting*. London: Crosby Lockwood and Son.
- Rodriguez, Miguel Alonso, Elena Andres, and Alberto Alvarez. 2011 "Graphical Tools for an Epistemological Shift. The Contribution of Protoaxonomerical Drawing to the Development of stonecutting Treaties." *Nexus Network Journal* 13,: 649-670.
- Sakarovitch, Joel. 2003. "Stereotomy, a multifaceted technique." *Proceedings of the First International Congress on Construction History*. Madrid.

ENDNOTES

¹ This text is partially referenced from:(Fallacara, Toward a Stereotomic Design: Experimental Constructions and Didactic Experiences 2009)

² Greek: στερεός (*stereós*) "solid" and τομή (*tomē*) "cut "

³ Euclid: Greek (Εὐκλείδης) 300BC (of the Elements and Optics), not to Vitruvius (Fallacara, Digital Stereotomy and Topological Transformations: Reasoning about Shape Building 2006)

⁴ Philibert de l'Orme is attributed with the origin of the stereotomic discipline. (Fallacara, Digital Stereotomy and Topological Transformations: Reasoning about Shape Building 2006)

⁵ Robin Evans in his Essay 'Drawn Stone' describes stereotomy as a 16th century technique developed through taits.

⁶ Defined terms of voussoir segmented arch: (Purchase 1904)

- The under-surface/soffit is called *intrudos*, the outer surface the *extrudos*
- The *voussoirs* are the separate stone blocks composing the arch, the *keystone* is the central voussoir
- The *springers* are the first stones on either side commencing the curve of the arch
- The *span* of the arch is the extreme width between the piers or opening; and springing line is that which connects the two points where the *intrudos* meets the inposts on either side.
- The *radius* is the distance between the centre and curve of the arch
- The highest point in the intrudos is called the *crown* and the height of this point above the springer is termed the *rise* of the arch.
- The *centre* is a point where the arch is struck, and lined drawn from the centre to the arch are radiating joints, and are also called *normals*. Variations in the normal and produce variations in the shape of the arch.
- All joints in arches should be radii of the circle/s or ellipses forming the curve of the arch, and will therefore converge to the centre or centres from which these are struck.

⁷ Other digital stereotomy practitioners include Richard Etlin and Luc Tambeorero as well as the work of MIT researchers J.A. Ochsendorf

⁸ Descharnes, R., & Prévost, C. *Gaudi - The Visionary*. New York: Viking Press, 1971; Collins, George R. *The designs and drawings of Antonio Gaudí* George R. Collins, Juan Bassegoda Nonell. Princeton, N.J. : Princeton University Press, c1983; Burry, Mark. *Antoni Gaudí, Expiatory Church of the Sagrada Família Barcelona 1882-*. London: Phaidon Press, 1993.

⁹ The entire process of the Stone vault pavilion can be found on this blog page: <https://equilibriumstone.wordpress.com/page/3/>

The significance of nanotechnology in architectural design

Ming Hu¹

¹American Institute of Architects, Washington D.C

ABSTRACT: Nanotechnology is one of the most active research areas that include a number of disciplines including civil engineering and construction materials. Nanotechnology is the understanding, control, and restructuring of matter on the order of nanometers (i.e., less than 100 nm) to create materials with fundamentally new properties and functions.

Traditionally nanotechnology has been concerned with developments in the fields of microelectronics, medicine and material sciences. However the potential for applications of many developments in the nanotechnology field in the area of architecture design is growing. The evolution of technology and instrumentation as well as its related scientific areas such as physics and chemistry is making the nanotechnology aggressive and evolutionary. There are many potential areas where nanotechnology can benefit construction engineering like its applications in concrete, structural composites, coating materials and in nano-sensors, etc. Nanotechnology products can be used for design and construction processes in many areas.

The recent developments in the study and manipulation of materials and processes at the nanoscale offer the great prospect of producing new macro materials, properties and products. But till date, nanotechnology applications and advances in the construction and building materials fields have been uneven. Exploitation of nanotechnology in concrete on a commercial scale remains limited with few results successfully converted into marketable products. The main advances have been in the nanoscience of cementitious materials with an increase in the knowledge and understanding of basic phenomena in cement at the nanoscale. This paper serves as report of existing nanotechnology application, with a focus of utilization of nanotechnology in architecture materials development and building system design. Meanwhile this paper will identify the main obstacle for nanotechnology's development and application in design/construction field.

KEYWORDS: Nanotechnology, Building Materials

1.0 INTRODUCTION

1.1. Definition of nanotechnology

The definition of nanotechnology is both controversial and consequential. It is controversial because how it is defined has important implications for how it is managed and marketed. Several international organizations that deal with standards are working on nano definitions, and their work may result in greater agreement. Currently, all the nano definitions based on the physics and chemistry of the technology relate to size. Everyone agrees that nano is the technology of the very small—the manipulation of things at the level of individual atoms and molecules. The U.S. National Nanotechnology Initiative (NNI), the interagency effort to coordinate federal funding for nano research and development, defines nanotechnology as “the understanding and control of matter at dimensions of roughly 1 to 100 nanometers”(www.nano.gov, accessed 9/18/06). A nanometer is a billionth of a meter. A human hair is 60,000–120,000 nanometers wide. A red blood cell is 2,000–5,000 nanometers wide (ibid.). Things at the nanoscale can be seen only with techniques such as super-magnifying scanning tunnel microscopes, which were first used in the mid-1980s.

1.2. The origin of nanotechnology

Over 50 years have passed since the Nobel Prize physicist Richard P. Feynman, with the lecture at the California Institute of Technology entitled “There’s plenty of room at the bottom”¹ has opened the way for innovations related to nanotechnology, prefiguring the possibilities associated with the transformation of matter at the molecular level. Studies conducted by Feynman and his intuitions have laid the basis for a radical transformation of nano-scientific horizon, starting from the possibility of miniaturization of computers to which much of technological innovations produced in the last fifty years is owed.

1.3. The significance of nanotechnology

Nanotechnology represents one of the fastest growing industrial sectors in recent years worldwide. The construction industry begins to look with increasing attention to nanotech innovations, identified as an

important resource to give a new impulse to market growth. Nanotechnology applied to building materials represents an example of how innovation increasingly combines dematerialization, eco-efficiency and knowledge-based approach to develop new classes of products – often substitute of conventional technologies, with the aim of opening new market sectors based on the paradigm of the green high-tech.

Recent innovations in construction materials driven by nanotechnologies application are based on the design of material properties in order to obtain the required performances, developing sophisticated transformation processes that allow realizing custom-fit products for specific architectural applications. Recently, there are more than 600 manufacturer-identified consumer products are available on the market using nanotechnology. Which is projected will enable 15 percent of globally manufactured goods worth \$2.6 trillion by 2014. ² The U.S. federal government budget for nanotechnology for fiscal year (FY) 2009 totals \$1.5 billion. China, Japan, Korea and several European nations are competing with the United States for the lead in developing nanotechnology, and Russia recently announced a \$5 billion for research and development program of nanotechnology (Elder 2007).

“What is so unique about the nanoscale? At this dimension, materials start to behave in ways different to their bulk counterparts. It also marks a crucial crossroads: the scale where artificial systems can interact with molecules and biological systems. A water molecule is just a little smaller than a nanometer (10⁻⁹ m); basic functional biological units like proteins operate on the nanoscale, while basic living entities like cells are 10-100 µm (where 1 µm or micron = 1 x 10⁻⁶ m) and bacteria 0.5-20 µm in size. (European Commission 2014)

Nanotechnology will present new opportunities to make the stuff of life – electronics, medicines, everyday products and even our cars and homes – better, more cheaply and using fewer raw materials.

So what could a nano-enabled future look like? Feynman was right in his prediction that the room-sized computers of the 1950s would be miniaturised to a single, hand-held device, but could he have had an inkling of the transformation that smart devices from mobile phones to tablet computers have wrought on modern life? Ultimately, every industry that involves manufactured items will be impacted by nanotechnology. As Aidan Quinn, who heads the nanotechnology group at the Tyndall National Institute, University College Cork says: “Nanotechnology will play a key role in developing cheaper or better performing electronic devices, sensors and solar cells than those available now.”

2.0. CURRENT APPLICATION OF NANOTECHNOLOGY IN BUILT ENVIRONMENT

2.1. Nanotech cement and concrete

In the case of many building materials, both those cement-based and certain types of polymers or composite materials, the observation of the physical-chemical properties at the nanoscale allows to rest the properties with such a degree of precision that is possible to “correct” and optimize the characteristics of material’s nanostructures depending on the final performance expected, even without the addition of nanomaterials. (J. Clarence 2008). In high performance concrete, for example, the modification of the mix-design (depending on the type and size of the aggregates, the type of additives and the water/cement ratio) can increase of mechanical strength and durability. Concrete is probably unique in construction in that it is the only material exclusive to the business and therefore is the beneficiary of a fair proportion of the research and development money from industry. More details are available on concrete than the other materials because much of the research described is performed in universities and research institutes and therefor is in the public domain.

Silica (SiO₂) is present in conventional concrete as part of the normal mix. However, one of the advancements made by the study of concrete at the nanoscale is that particle packing in concrete can be improved by using nano-silica which leads to a densifying of the micro and nanostructure resulting in improved mechanical properties. Nano-silica addition to cement based materials can also control the degradation of the fundamental C-S-H (calcium-silicatehydrate) reaction of concrete caused by calcium leaching in water as well as block water penetration and therefore lead to improvements in durability. Related to improved particle packing, high energy milling of ordinary portland cement (OPC) clinker and standard sand, produces a greater particle size diminution with respect to conventional OPC and, as a result, the compressive strength of the refined material is also 3 to 6 times higher (at different ages) (J. Clarence 2008).

2.2. Nanotech steel

Research has shown that the addition of copper nanoparticles reduces the surface unevenness of steel which then limits the number of stress risers and hence fatigue cracking. Also research into the refinement of cementite phase of steel to a nano-size has produces stronger cables, high strength steel cables are used in bridge construction and in pre-cast concrete. (J. Clarence 2008) Tensioning and stronger cable material would reduce the costs and period of construction, especially in suspension bridges as the cables are run from end to end of the span. Nanoparticles are reducing the effects of hydrogen embrittlement and

improving the steel micro-structure through reducing the effects of the inter-granular cementite phase. The additional of nanoparticles of magnesium and calcium makes the HAZ(Heat Affected Zone) grains finer in plate steel and this leads to an increase in weld toughness. "Two relatively new products that are available today are Sandvik Nanoflex(produced Steel Corp). Both are corrosion resistant, but have different mechanical properties and are the result of different applications of nanotechnology. Sandvik Nanoflex⁵ has both the desirable qualities of high strength and resistance to corrosion. MMFX2 steel has a modified nano-structure that makes it corrosion resistant and it is an alternative to conventional stainless steel, but a lower cost." (Crystal Research Associates 2012)

2.3. Nanotech wood

Wood is composed of nanotubes or "nanofibrils"; namely, lignocellulosic(woody tissue) elements which are twice as strong as steel. Harvesting these nanofibrils would lead to a new paradigm in sustainable construction as both the production and use would be part of a renewable cycle. Some developer have speculated that building functionality onto lignocellulosic surfaces at the nanoscale could open new opportunities for such things: self-sterilizing surfaces, internal self-repair and electronic lignocellulosic devices. "These non-obtrusive active or passive nanoscale sensors would provide feedback on product performance and environmental conditions during service by monitoring structural loads, heat losses or gains, temperatures, moisture content, decay fungi, and loss of conditioned air. Currently, however, research in these areas appears limited." (J. Clarence 2008)

Due to its natural origins, wood is leading the way in cross-disciplinary research and modeling techniques which have already borne fruit in at least two areas. Firstly, "BASF have developed a highly water repellent coating based on the actions of the lotus leaf as a result of the incorporation of silica and alumina nanoparticles and hydrophobic polyers, And, secondly, mechanical studies of bones have been adapted to model wood, for instance in the drying process". (European Commission 2009)

In the broader sense, nanotechnology represents a major opportunity for the wood industry develop new products, substantially reduce processing costs, and open new markets for bio-based materials.

3.0. CURRENT APPLICATION OF NANOTECHNOLOGY IN ARCHITECTURE DESIGN

3.1. Insulation

Nanomaterials stand to revolutionize insulating methods because they are structured at the molecular level to trap air between particles. They are far more efficient than traditional insulators like fiberglass and polystyrene which work at the macro level without the environmental harm associated with level, without the environmental harm associated with those materials. And because it traps air at the molecular level, an insulating nano-coating even a few thousandths of an inch thick can have a dramatic effect.

"Nanogel insulation, made by the Cabot Corp is a form of aerogel, the lightest-weight solid known as "Frozen smoke", nanogel is 5% solid and 95% air". (Roya Naseri, Reze Davoodi, 2011), The high air content means that a translucent panel 3.5 inches thick can offer a high insulating value. Another company, Nanocoating are used to insulate both new and existing materials, and to protect wood, metal and masonry, without the hazardous off-gassing of many other coating. Nanoseal, makes insulating paint for buildings. Its insulating coating, applied in a layer only seven-thousandths of an inch thick, is being used on beer tanks in Mexico by Corona, resulting in a temperature differential of 36 degrees Fahrenheit. (European Commission 2009)

3.2. Self-cleaning coating

Nanotechnology may be good for our health too. The Hongkong subway system has coated its cars' interiors with titanium and silver dioxide coatings that kill most of the airborne bacteria and viruses they come into contact with. And in cleansers and interior paints used around the world, Behr Premium Plus Kitchen & Bath Paint is one example. Nano-coating can break down dirt as well. PPG Industries and Pilkington Glass both offer self-cleaning window glass that harness nanotechnology. The Jubilee Church in Rome features self-cleaning concrete: Photocatalytic titanium dioxide nano-particles in the precast panels, manufactured by Italcementi, make them shed dirt. The panels trap airborne pollutants in a nano-particle matrix on their surface, then decompose them. Similar depolluting nano-coatings can be applied to almost any surface, making it a smog-eating machine. In the near future, road surfaces, bridges, and tunnels may be able to counter act pollution. This type of self-cleaning coating is base on Titanium Oxide(TiO2) technology. "Titanium dioxide is a widely used white pigment because of its brightness. It can also oxidize oxygen or organic materials, therefore, it is added to paints, cements, windows, tiles, or other products for sterilizing, deodorizing and anti-fouling properties and when incorporated into outdoor building materials can substantially reduce concentrations of airborne pollutants. Additionally, as TiO2 is exposed to UV light, it

becomes increasingly hydrophilic (attractive to water), thus it can be used for anti-fogging coatings or self-cleaning windows". (Kumar and Devi 2011)

3.3. Fire-protective glass

This is achieved by using clear intumescent layer sandwiched between glass panels(an interlayer) formed of fumed silica(Si₂) nano-particles which turns into a rigid opaque fire shield when heated.

4.0. CURRENT OBSTACLE

Cost and relatively small number of practical applications, for now, hold back much of the prospects for nanotechnology. However, construction also tends to be a fragmented, low research oriented and conservative endeavor and this plays against its adoption of new technologies, especially ones that appear so far removed from its core business. Materials though, as mentioned above, are construction's core business and the prospects for more changes are significant in the not too distant future. The main reasons that lead to the slow beneficiary of building sector from nano-technology could be concluded in the following:

- The majorities of architects especially in the developing country are not familiar with the applications of nanotechnology in building sector and they are ignorant with the huge potentiality of this technology to improve or introduce new building materials and related building systems.
- There is also a large research gap for understanding the potential for release of nanoparticulates due to weathering of these novel coatings despite recognition of considerable environmental uncertainties and concern at end-of-life.
- The lack of scaled up exploration research in institutions, most research projects are focusing on understand the capacities of materials.

4.1. Lack of business model

One of the largest challenges facing nanotechnology today is the lack of a business model to treat new materials as something other than commodities. Over the past century conventional materials prices have fallen relative to other goods, thus nanomaterials are often asked to compete with conventionally produced materials at costs that are lower by orders of magnitude. It can be a very different hurdle for a nanomaterials producer to demonstrate that a new quantum material may offer performance gains sufficient to compete with existing products.

4.2. Cost

Apart from the factors mentioned in the 4.0 of a fragmented and conservative business, cost or more accurately cost-to benefit is a major concern. Carbon nanotubes(Nano Steel) at the moment are priced at 20 to1000/gram depending on quality and this cost is simply incompatible with the 12bn tonner/yr concrete industry. This issue also touches on the topic of scalability, for even those processes, e.g. nano-vapour deposition, that might look promising in research may be difficult or cost prohibitive to do on an industrial scale. Furthermore, some of the nanotechnology research has no immediate practical application to construction and this is certainly a factor that holds back research spending. Something that is lacking and could certainly a factor that holds back research spending. Something that is lacking and could certainly help in this regards, is greater communication between researchers and industry.

4.3. Weak academic collaboration and information sharing

Nanotechnology is absolutely interdisciplinary, up to now research teams have been mainly composed of specialists on a single discipline or research field. Investment on new production processes is a serious drawback, especially for early adopters. Given nanotechnology's interdisciplinary nature, work across fields such as business, architecture, engineering, biology, chemistry and physics is also especially important and this is something that is lacking and needs to be addressed if nanotechnology, not just in construction but more generally, is to progress to the future that is hoped for it.

However, the potential effects of nanotechnology on construction are largely unknown to the construction profession in general, even though specific research is being carried out all over the world in universities and other institutes. Those provide pointers to what will soon be available to industry. Many of these advances are due to arrive within the next 5 years and in order to fully benefit from this new industrial revolution, a concerted effort is needed to overcome the key barriers of lack of knowledge and conservatism in construction regarding nanotechnology. Nanotechnology is a complex and deep subject and it is next to impossible to grasp for those who are not actively involved, therefore, awareness of research done can only be increased by educating both students and professionals through easily digestible information made available through universities, relevant institution's journals and other sources.

5.0. FUTURE RESEARCH IN NANOTECHNOLOGY

In conclusion, nanotechnology is disruptive and offers the possibility of great advances whereas conventional approaches, at best, offer only incremental improvements. Nanotechnology is not exactly a new technology, rather it is an extrapolation of current ones to a new scale and at that scale the conventional tools and rules no longer apply. Nanotechnology is therefore the opposite of the traditional top-

down process of construction, or indeed any production technique, and it offers the ability to work from the “bottom” of materials design to the “top” of the built environment. However, many of the advances offered by nanotechnology, be they for economic or technical reason, are years away from practical application, especially in the conservative and fragmented construction business.



Figure 1: A selection of field where nanotechnology applications are being explored, Source: New Building Materials & Construction World (NBM&CW), August 2011.

Nanotechnology also presents an opportunity to rejuvenate traditional industries, like chemicals and catalysts, papermaking, and agriculture, bringing innovations in sustainability, processing, energy efficiency, recycling, emissions control and waste treatment.

In the future, the environment will interact with occupants in way hardly imaginable today, creating what a 2005 United Nations report calls “An internet of things”. Tiny nano-sensors embedded in building materials will soon be able to track movement and detect temperature changes, humidity, toxins, weapons, even money. Sensors will pick up on user’s preferences and attributes, which will then trigger responses in the intelligent objects around them, dimming the lights, altering the temperature, or as is already happening with “push” technology that marketers use to blitz cell phones, altering them to nearby sales and events. In the future, the design and construction of buildings will incorporate a rich network of interacting, intelligent objects, from light-sensitive, photochromic window to user-aware appliances.

The market for nano-enhanced building materials in the US is expected to grow to \$400 million by 2016. \$4 billion a year is known to being invested into Nanotech R&D worldwide, resulting in a pipeline of materials and products that will transform the way future buildings are constructed (European Commission 2014). A central aim of nanotechnology is to consistently use the minimum amount of raw material and energy: from an economic as well as an ecological point of view “nano” is a winning factor. From the point of view of the client or the user, the most realistic and sensible application of nanotechnology focuses on aspects of aesthetics, functionality, economy and sustainability.

The use of nanotechnology in the design and construction disciplines usually involves the optimization of existing products or common materials. Nanotechnology brings us a step closer towards customized materials with specific individual properties and represents a shift away from the catalogue of standard materials. Surfaces emancipate themselves from the underlying material, developing clearly defined functions that can differ fundamentally from the substrate material. This helps make products and materials more economical and also conserves resources. The application of nanotechnology makes a concrete contribution in the field the construction industry to the following areas:

- Optimization of existing products
- Damage protection
- Reduction in weight and/or volume
- Reduction in the number of production stages
- A more efficient use of materials

Author is currently conducting a research project “Smart Design Strategies for Novel Pollutant Reduction TiO2 Coatings”. Heterogeneous photocatalysis with TiO2 is a rapidly developing field in environmental engineering with great potential for reducing a variety of air pollutants (Ohko, Tryk et al. 1998, Fujishima, Hashimoto et al. 1999, Irie, Watanabe et al. 2003, Hashimoto, Irie et al. 2005). As early as 1970, researchers discovered the hydrolysis of water in oxygen and hydrogen in the presence of light, by means of a TiO2-anode in a photochemical cell (Kumar and Devi 2011). Now, there is a wide range of products

marketed for both indoor and outdoor use. In the research arena, a number of efforts are underway in the academic and regulatory community to test and quantify the pollution reduction effectiveness of these novel coatings. Regarding the reduction of air pollution due to traffic in urban areas, early research indicates the application on building surfaces via cementitious materials can provide optimal results (Maggos, Plassais et al. 2008). To ensure the efficiency of the photocatalyst, its presence at the surface of the material is crucial as it has to have sunlight in order to be activated.

Besides being at the surface, research has also indicated that maximizing the total surface area provides best results (Linsebigler, Lu et al. 1995, Tian, Fu et al. 2008); however, little work has been conducted to examine how much may be lost due to abrasion and weathering in real applications. Lab-scale work indicates that a potential application is TiO₂ as a thin layer on cementitious material; therefore concrete tile facades would be worth investigating further.

This research project is to study how smart design strategies can maximize the positive impacts of novel TiO₂ coatings by taking advantage of site-specific conditions. Specifically, this research will test physical, chemical, and environmental performance parameters in order to validate the pollution reduction potential for coated façade shading devices. This research will also quantify the degree of weathering the coating experiences in specific environments and whether or not this results in nano-particulate release. In regards to the smart design strategies, it is our hypothesis that the shape of the façade shading device will be very important. More random, omnidirectional shapes may provide more surface area to react with pollutants as well as scatter sufficient UV light to aid in the chemical reaction.

REFERENCES

- A.Ritter, 2007. *Smart Materials*. Birkhauser Verlag AG
- Breggin, L. and J. Pendergrass, 2007. *Addressing Nanotechnology Waste and Product Disposal: Can the Superfund Safety Net Catch Tiny Particles?* *Journal of environmental law* 19(3): 323.
- Crystal Research Associates. Dec.2012. *Nanotechnology and the built environment: Investing in Green Infrastructure*.
- European Commission. 2007. *Proceeding of NanoEuroForum 2007: Nanotechnology in Industrial Application*.
- European Commission. 2009. *Nanoscience and Nanotechnologies: an action plan for Europe 2005-2009*. Bruxelles.
- European Commission.2014, *Nanotechnology: the invisible giant tackling Europe's future challenges*, Luxembourg: Publications Office of the European Union.
- F. A. Hemeida, 2010, *GREEN NANOARCHITECTURE (M. Thesis)*, University of Alexandria, Arch. Dpt., Feynman RP(1960) *There's Plenty of Room at the Bottom*. *Caltech Engineering and Science* 23:22-36
- Gao, J., J. Bonzongo, G. Bitton, Y. Li and C. Wu, 2008. *Nanowastes and the environment: Using mercury as an example pollutant to assess the environmental fate of chemicals adsorbed onto manufactured nanomaterials*. *Environmental Toxicology and Chemistry* 27(4): 808-810.
- Guroi, M. D. 2006. *Photo-catalytic Construction Materials and Reduction in Air Pollutants*, California State University, Sacramento, Center for California Studies.
- Hashimoto, K., H. Irie and A. Fujishima , 2005. *TiO₂ photocatalysis: a historical overview and future prospects*. *Japanese journal of applied physics* 44(12R): 8269.
- J. Clarence. July 23, 2008. *Nanotechnology Oversight - An Agenda for the Next Administration*, PEN 13.
- J. Clarence. July 23, 2008. *Nanotechnology Oversight - An Agenda for the Next Administration*, PEN 13.
- J. Clarence Davies. April 28, 2009. *Oversight of Next Generation Nanotechnology*, PEN 18.
- J. Ortego. Oct. 2008. *Nanotechnology-Energizing the Future Nanofrontiers*, Newsletter
- Kumar, S. G. and L. G. Devi (2011). *Review on modified TiO₂ photocatalysis under UV/visible light: selected results and related mechanisms on interfacial charge carrier transfer dynamics*.*The Journal of Physical Chemistry A* 115(46): 13211-13241.
- Linsebigler, A. L., G. Lu and J. T. Yates Jr. 1995. *Photocatalysis on TiO₂ surfaces: principles, mechanisms, and selected results*. *Chemical reviews* 95(3): 735-758.
- Lorraine Farrelly, November 2008, *Basics Architecture 02: Construction & Materiality*, AVA Publishing.
- Maggos, T., A. Plassais, J. Bartzis, C. Vasilakos, N. Moussiopoulos and L. Bonafous 2008. *Photocatalytic degradation of NO_x in a pilot street canyon configuration using TiO₂-mortar panels*. *Environmental monitoring and assessment* 136(1-3): 35-44.
- Mattia Federico Leone. 2012. *Nanotechnology for Architecture. Innovation and Eco-Efficiency of Nanostructured Cement-Based Materials*, *J Architec Eng Technol*
<http://www.smt.sandvik.com/en/materials-center/material-datasheets/strip-steel/sandvik-nanoflex/>
- Michelle Addington, November 2004, *Smart Materials and New Technologies in Architecture*, Architectural Press, Elsevier.
- Ohko, Y., D. A. Tryk, K. Hashimoto and A. Fujishima, 1998. *Autoxidation of acetaldehyde initiated by TiO₂ photocatalysis under weak UV illumination*. *The Journal of Physical Chemistry B* 102(15): 2699-2704.

Roya Naseri, Reze Davoodi, 2011. *Commercial Commercialization of Nanotechnology in Developing Countries*. Singapore: IACSIT Press
S. Mann, Nov. 2006 *Nanotechnology and Construction*. Nanoforum report
Sylvia Leydecker, Feb 2008, *Nano-Materials in Architecture, Interior Architecture and Design*, Birkhauser Verlag.

Towards digital containerized factories of composite architectural panels for complex shaped buildings

Daniel Chung¹, Kihong Ku²

¹Drexel University, Philadelphia, PA

²Philadelphia University, Philadelphia, PA

ABSTRACT: Complex building shapes requiring double curved or deformed surfaces can be a difficult and expensive aspect of design and construction for façade materials. Most often building envelopes that create complex shapes do so by a compilation of many smaller elements to create a larger object or form. These elements are frequently prefabricated in specialized workshops that allow for the use of digital fabrication tools that can reference 3D design models. Some of the difficulties that arise in this type of process are long lead times, extended material travel distances (to and from digital workshops) and reduced flexibility in overcoming on-site construction variations. Over the past year the authors researched new methods using fiber-reinforced composite sandwich panels to produce on-site digitally fabricated curved panels for use in complex shaped buildings. This research examined the material properties, manufacturing methods and fabrication techniques needed to develop a proof of concept system using readily available production technology that can be packaged in a mobile containerized facility for on-site panel production. This paper will present production materials, methods, assembly techniques and design proposals for a proof of concept digital containerized panel factory. Comparison of production methods will be presented and recommendations for future work will be included.

KEYWORDS: Digital Facade Fabrication, Fiber-Reinforced Plastic, Mobile Fabrication

INTRODUCTION

Off-site fabrication has been typically identified with various benefits including cost reduction, enhanced construction efficiency, and improved quality. Cost reduction is related to reduction of waste, rework, manual handling, labor productivity, etc. (Pasquire et al., 2004). Construction efficiency benefits from the possibility to minimize joints, maximizing the size of elements, minimizing the disparities between trades and minimizing construction tolerance. Despite the many benefits of off-site fabrication, there have been growing concerns about the increasing cost of transportation and packaging, size limits of shipping units, particularly in the case of complex shaped panels, ergonomic issues during site erection of panelized components which prioritize packing efficiency over on-site storing and erection sequencing. A number of recent projects have adopted near-site (Ku et al. 2012) or on-site fabrication (e.g., R-O-B mobile fabrication unit¹, Facit Homes²) approaches which explore a paradigm shift from centralized manufacturing to distributed manufacturing. Near-site fabrication involves preassembling modular units such as integrated mechanical, electrical, and plumbing ceiling racks in warehouse spaces near the jobsite. Components such as HVAC ducts, piping and electrical conduits, etc. are shipped and preassembled in a warehouse into modules. This simplifies on-site assembly issues including trade coordination, quality control, tolerance issues in addition to shipping and schedule. On-site fabrication may involve building temporary production plants (e.g., concrete batch plant) or mobile factories. Cold-formed sections from steel sheet, strip, plates flat bars in a roll-forming machine, press brake, or bending brake operations, allow easy fabrication and mass production (Gann, 1996). A Virginia company produces 25-foot containers accommodating galvanized steel panel-forming machine and hydraulic guillotine which are shipped to job sites to transform coils. A London based firm, Facit Homes ships a CNC router in a shipping container to mill modular elements with snap on connectors to assemble the building onsite. The advancements of digital design and manufacturing offer opportunities to combine this containerized fabrication idea with a digital process.

The paradigm shift to containerized fabrication offers opportunities to produce non-volumetric preassembled units. These units can be skeletal, planar or complex panel systems or, cladding panels. Fully enclosed spatial units such as bathroom pods cannot be built in these container units because of the limited space. Thus fully enclosed spatial units would not be considered for mobile production. The idea of containerized factories assumes a linear process where material is entered as an input into this mobile unit, processed by equipment, and produced as an output. The advances in materials such as composites, provide fertile ground for research and development of architectural materials and systems which can potentially take advantage of such containerized processes.

The authors are presenting explorations of a prototype for the production of complex shaped architectural composite panels. The goal is to identify the requirements and specifications of the production equipment and production unit. The application of this unit is on façade systems as it is one of the crucial design features that architects and builders attempt to achieve cost effectively, satisfying an owner's goal of exploiting the enclosed space to maximum

advantage (Chudley and Roger, 2010). In this article, first a review of existing fabrication methods is discussed. Then preliminary experiments and parameters of a production unit are presented.

1.1. General overview of existing methods

To help develop a new method for producing complex three dimensional architectural panels for use in building envelope assemblies this research began by reviewing the existing practices typically employed in current or recent architectural construction. By examining the difficulties and most pressing issues of existing methods the research team sought to develop new manufacturing techniques to address the most significant obstacles facing more widespread access to complex three dimensional panels.

1.2. Material and forming

To begin understanding the development of complex three dimensional architectural panels one can conceptually categorize techniques based on two primary elements. One element is the choice of material for the architectural surface. This material could be wood, plastic, glass, steel, concrete or any material that has already been used to make complex three dimensional architectural surfaces. The other element is the choice of a deformation or forming technique. This can be broadly sub-categorized into four methods: additive, subtractive, formed and deformed.

1.3. Additive

An additive technique for a complex three dimensional architectural surface could be similar to 3D printing and might utilize many smaller identical elements systematically assembled to create a larger surface. This was not found to be a widespread technique due to the size limitations of 3D printing and the lack of appropriate materials available for use in architectural surfaces that would be expected to be durable in exterior weather conditions. More traditional additive techniques would be to utilize many dissimilar pieces to construct a framed surface element that is then mounted or fastened to a larger structural support. This would be more akin to typical rainscreen panels or facades that utilize a finished material on the outer surface and a hidden structural system on the rear side. While this technique is widely used for flat surfaces using rigid sheet goods, and even single curved surfaces (such as those made from composite metal panels), they are rarely used for more complex double and triple curved architectural surfaces due to the extreme difficulty in fabricating an acceptably smooth double or triple curved surface from existing rigid sheet goods.

1.4. Subtractive

Subtractive methods essentially start with a larger mass of material and systematically remove material to carve out the desired complex surface. Digitally driven subtractive processes often use Computer Numerical Control (CNC) routers to remove material to create the desired surface. This technique has been used to create low relief architectural panels, particularly of stone materials that cannot be cast. One of the difficulties of this technique though is the large amount of waste and cost from the subtractive process. Usually this waste material cannot be successfully recycled for further use in the subtractive process. Another weakness of this method is the time needed to fabricate the surface. Since durable exterior building materials often are dense or have high surface hardness, subtractive process must slowly cut away the material. Thus a 4'x8' stone panel with one or two inches of relief depth will take hours if not days to complete and only provide minimal depth or overall curvature.

1.5. Forming

Forming techniques often use subtractive methods to create formwork or casting beds for the creation of complex three dimensional shapes. This is akin to making a plaster or concrete pour into a complex form so that when cured the formwork can be removed to reveal the desired surface. This is presently the most frequently used technique in producing complex three dimensional architectural panels that have more than a single curve within the panel. Most often this is produced by first CNC cutting a foam bed to become the negative or the casting surface and then casting high strength cementitious fiber reinforced material against the negative to create the desired positive surface. While foam and cementitious materials are relatively cheap, the process is laborious and time intensive since each foam bed is essentially treated as a single use disposable formwork and each panel must be cured and surface treated after being released from it's negative. Thus time is spent on creating the forming bed, casting the material and then surface finishing the material once cured. Injection modeling, often used in product and furniture manufacturing uses more durable forming surfaces (often CNC cut aluminum molds) but requires a high quantity of repeated elements to be economical and thus has not been appropriate for non-uniform or non-repetitive architectural surfaces.

1.6. Deforming

Deformation processes most often utilize a sheet good that can be heated up and then plastically deformed by pressing it against another object to create a complex three dimensional surface. Thermoforming and vacuum forming have been used to create architectural surfaces primarily out of plastics. The benefit of this technique is that it reduces fabrication time by removing the curing process typical of forming techniques. The same limitation of creating a formable bed or negative surface used in forming techniques is required in this process. Large local depth

variations and sharp changes in surface direction may also not be well resolved using deformation techniques due to uneven plastic deformation of the sheet product causing local tearing or thinning to occur that may result in unacceptable panel weaknesses.

1.7. Form bed as limiting factor

Given the dimensional and economic limitations of current additive and subtractive digitally driven fabrication techniques in the manufacture of complex three dimensional architectural surfaces and the more frequent use of forming and deforming methods in state of the art architectural facade installations the forming bed was identified as a significant target for research in improving fabrication ability. In both forming and deforming techniques, the creation of a disposable form bed via CNC methods places a large amount of material, space and time devoted to the creation of the negative surface rather than the end product which is the surface positive. The time, space and materials required to create the form beds and perform the forming/deforming has limited production of complex three dimensional facade panels to off-site fabrication labs which has increased lead times and cost related to packaging and shipping finished goods to job sites.

Shipping costs for finished goods sent to a job site almost always are more expensive than shipping costs for raw goods due to the higher level of care required in handling and inefficiencies inherent in the non-standard sizes of finished goods. Thus it should be advantageous to be able to site fabricate complex three dimensional panels on demand using a technique that allows for a reusable form bed that can create multiple unique three dimensional surfaces. Thus the concept of developing a reusable rapidly deformable bed for forming and deforming operations was identified by the research team. This would remove the material and fabrication time needed to make the surface negative and would then only require that the majority of the raw goods to be shipped are those that are part of the end product. This should make mobile fabrication of complex three dimensional architectural facade panels less expensive and more readily available.

1.8. Material exploration

This research also included exploration of materials that would be appropriate for site fabrication via forming and/or deforming methods that could be coupled with a deformable bed. Material goals were that the chosen material should be commercially widely available, durable in exterior exposure scenarios, be easily connected to fasteners and framework for structural support, easily transportable, have low site energy demands during fabrication, cure or deform rapidly, be lightweight, could be used in a multilayer assembly (to add insulation), and be dimensionally stable over time. As such the research team examined existing plastic sheet goods, cementitious materials, fiber reinforced resins, and types of reinforcing fibers to develop a proof of concept system prototype for the fabrication of complex three dimensional architectural facade panels.

2.0 METHODOLOGY

2.1. Vacuum forming study

To gain perspective on the use of forming and deforming methods small experimental studies were conducted by the research team using existing techniques. Vacuuming forming was one of the first methods explored and 1/16" sheets of Plexiglas were used over a laminated cardboard forming bed. Numerous sheets of cardboard were laser cut to create a three dimensional surface with each layer of cardboard standing vertically on its edge to allow for air to be pulled through the assembly. The cardboard pieces were mechanically held together to form the bed. Fig. 1 shows the cardboard assembly without plastic and Fig. 2 shows a 1/16" inch thick sheet of Plexiglass vacuum formed onto the

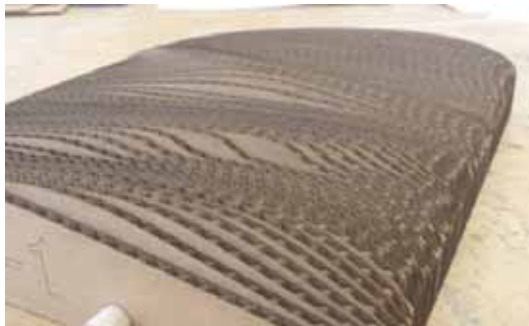

Figure 1: Cardboard test forming bed
(Jesse Smith 2014)

cardboard bed. While as a small one foot by one foot demonstration this may be simple and easy to accomplish scaling this to the size of a larger four feet by eight feet architectural panel may not be practical since much thicker plastic materials would be needed and assembling the bed would be time intensive. Creating the required vacuum force and heat while maintaining control over the quality may also prove to be difficult at a larger scale.

Having identified that vacuum forming requires large forces to be exerted on the forming bed the research team surmised that any deformable bed system using vacuum forming would require high strength resistive capabilities to support the forces generated during the vacuum forming. High strength resistance in a deformable bed would most likely require either high strength motors.

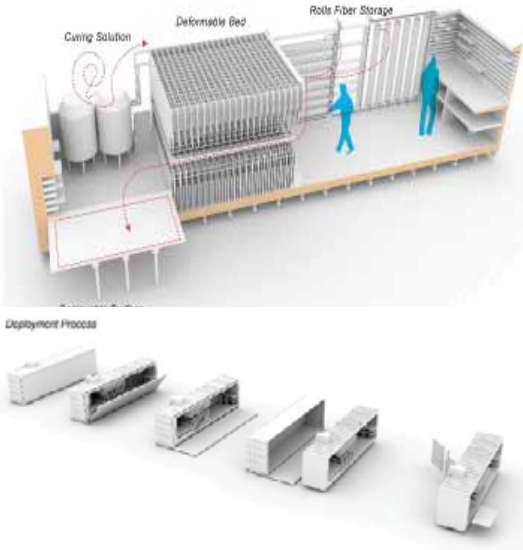

Figure 2: Plexi Vacuum formed on cardboard (Smith 2014)

pistons or actuators and thus require a high amount of energy during the process. Similarly other deformable techniques generally would require either high energy use for deforming the material and or substantial heating of materials to promote thermoformed deformations. This led the team to steer away from deformation techniques and instead the team focused on methods of forming the architectural surfaces using materials such as resins, epoxies and fiber reinforcement that could be placed on top of a deformable bed.

2.2. Projecting mobile implementation

While exploring the forming methods and materials the team also concurrently studied simulated outcomes in regards to creating a mobile fabrication facility. Virtual models and rendering were created to begin to understand the layout and processes that would be needed. This was done to help guide the research towards panel fabrication methods and techniques that would be compatible with the space and resource limitations that would be present in a mobile facility. This also helped the team imagine how the various stages of the fabrication process could be organized to increase panel production and raw material processing capacity. A starting point for the design of the mobile facility was a 40 feet long shipping container. It was quickly apparent that good circulation, ventilation and external power connection would be critical for the mobile facility to operate effectively. Fig. 3 shows a sequence of renderings based on these mobile implementation sketches.



2.3. Virtual panels

To also help in understanding the needed outcomes for a deformable bed and proposed complex shaped panels such as what might be a typical curve or slope needed in a façade panel, the team also generated three dimensional models of double and free-form curved panels that were part of larger architectural façade assemblies. Fig. 4 shows some early studies in taking three dimensional surface models and developing panelization strategies to create a grid of panels that could be made on a deformable bed using square or rectangular edge boundaries. Fig. 5 is a model of a double curved surface made from 115 panels. Fig. 6 is a model of a free-form surface with increased resolution using 231 panels.

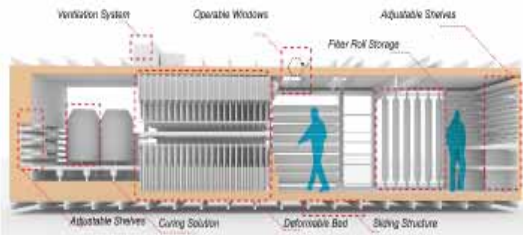

Double Curvature

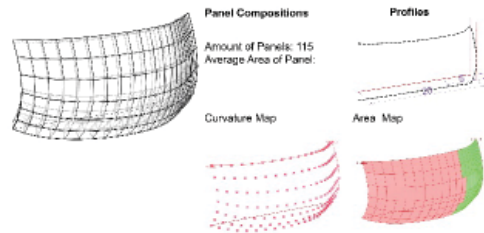

Figure 3: Double Curved Panelization Sketch (Rivera 2014)

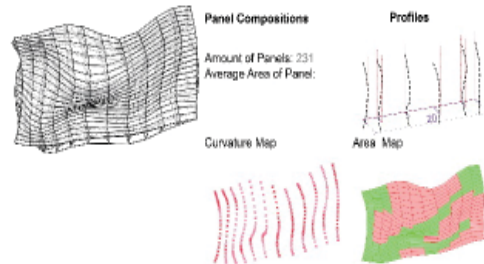

Figure 4: Free-Form Panelization Sketch (Rivera 2014)



Figure 5: Mobile Fabrication Sketches (Philip Rivera 2014)

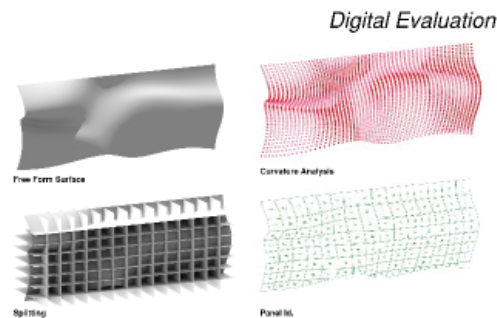

Figure 6: Façade Surface to Panelization (Rivera 2014)

The team imagined that mobile fabrication would not supplant traditional off-site fabrication but could be leveraged to create on-site panels for façade areas with highly demanding edge alignment conditions. Thus if a panel has large areas of edge deformation these panels might have greater failure rates during installation (due to gaps that are too wide or neighboring panels that don't properly align). These panels then could be specifically targeted for onsite production after the majority of other simpler panels have been installed. Then laser measurements techniques using LIDAR equipment could provide actual dimensions that could be used to adjust the digital models before fabrication. This could drastically reduce the turnaround time for pieces that are sent back due to poor fit, misalignment or incorrect fabrication. Figures 5 and 6 show highlighted areas in green that were calculated to have the greatest surface deformation and would be likely target areas for on-site fabrication. In this way design and fabrication teams could evaluate and plan for fabrication at both onsite and offsite facilities to maximize their time and production advantages.

2.4. Deformation Bed via Nickel Titanium

The creation of a digitally driven deformable bed that could replace the standard disposable CNC cut foam beds with something that could be reused and quickly reformed led the research work into the exploration of two distinct alternatives. The first alternative was the use of Nickel Titanium or nitinol wire, also known as memory wire. Nitinol has the unusual ability to perform a solid-state transformation (known as a martensitic transformation) between two defined states as a result of changes in temperature. This change in temperature is most often created by heating the wire through an electric current. Essentially at lower temperature the wire can be elongated and deform, at higher temperature the wire shortens and returns to its original shape. By controlling the temperature via electric current through the wire a controlled deformation of the wire can be created. When using the wire as a woven component on a textile surface the nitinol wire can cause local area deformations that produce three dimensional surfaces.

One of the team members was already familiar with using nitinol in textiles and was able to create early stage examples of nitinol woven into a fabric to create a deformable bed. Fig. 7 shows an example of a circular pattern using memory wire and Fig. 8 shows an example of a rectilinear pattern also using memory wire. These early attempts while exciting and innovative proved to be highly restricted in the amount of load they could support and thus proved to be currently unsuitable for supporting the loaded needed in forming and casting a resin or epoxy panel for an architectural façade. Perhaps if the nitinol was of thicker diameter and the spacing was tighter increased loads could be supported, but this was beyond the scope the research project at that time.



Figure 7: Actuator Deformation Bed (Anderson 2014)

2.5. Deformation bed via actuators

Given the need to create a panel with high surface variation and a casting surface that could support the weight of resin and other potential façade materials the team focused on the creation of a mechanically driven solution using motors and/or solenoid actuators that could be digitally driven through a microprocessor with a relay array. This would allow for a surface resolution that could be closely pair with the number of actuators used as well as the stepping height of each actuator. For the initial attempt simple push pull actuators are being used to create a three height actuator array with each actuator being able to be addressed individually. Fig. 9 shows the actuator array draped with a sheet of clear plastic before casting resin or epoxy has been applied. Preliminary tests have shown that these actuators have ample load capacity for supporting our expected casting activities.

3.0 RESULTS & DISCUSSION

This research project is scheduled to continue through the remainder of the 2014-2015 academic year and early trials of casting materials for panel creation on the actuator driven deformable bed have recently begun. The results from these trials as well as a working proof of concept mock-up of a process to rapidly produce a complex three dimensional panel is expected to be shared via publication in the 2015-2016 academic year. We expect to also develop recommendations for the materials that are well suited for this process and methods to improve the next iteration or prototypes of rapidly deformable casting beds that can be utilized in mobile panel fabrication.

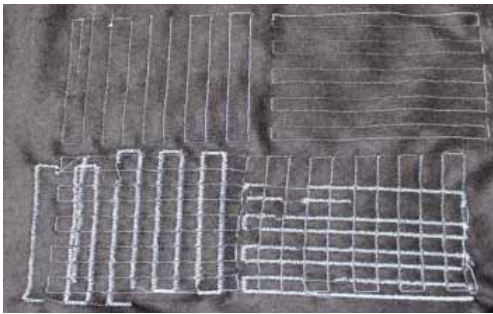

Figure 8: Nitinoal rectangular pattern study (Anderson 2014)

The research team has discussed improvements and alternate methods that could be targeted for future research and development. One proposed method is to use spray foam through a computer controlled flow nozzle that is mounted to the moving arm of a CNC platform. This would allow for insulation to be added on the back side of the panel surface. This technique could also work well to increase curvature and pattern resolution. By using a slow rise spray foam and a laser measuring device the addition of spray material could be calibrated to create geometries and forms that could be added on top of the deformable bed and become the forming bed for the resin/epoxy panels. In addition the CNC router could be used to make minor alterations to the spray foam bed before casting and also could be used to engrave patterns or information on the outer panel surface. In this way a high resolution deformation could be created with very little material waste and with

far less time than using CNC exclusively. Essentially the actuator bed would provide the base for large deformations, the spray foam would provide medium resolution deformation and the CNC process would allow for highly detailed resolution.

CONCLUSION

This paper discussed the development of a prototype of a containerized fabrication system for complex-shaped architectural composite panels. So far the investigations have concentrated on composite material as an emerging resource for architectural façade systems, the associated production systems, dynamic mold processes/materials, and tested various mechanical systems as actuators. Through trial and error, prototyping has involved system development for electric circuits, mold membrane, actuation systems, and fiber composites. Following work will determine the best material that provides cost effective and efficient mold construction. Alternate fiber composite material will be tested. Based on the findings of the prototype, recommendations for future research and a roadmap for commercialization will be established.

REFERENCES

- Beall, G. 1998. *Rotational Molding: Design, Materials, Tooling, and Processing*. Munich: Hanser
- Chudley, R. G., Roger. 2010. *Building Construction Handbook - Incorporating Current Building and Construction Regulations* (8th Edition).
- Erhard, G. 2006. *Designing with Plastics*. Munich: Hanser
- Gann, D. M. 1996. Construction as a manufacturing process? Similarities and differences between industrialized housing and car production in Japan. *Construction Management and Economics*(14), 437- 450.
- Ku, K., Broadstone, P., and Colonna, A. 2012. Towards On-Site Fabrication: A Case Study on Multi-Trade Prefabrication, Offsite Theory and Practice of Architectural Production, 2012 ACSA Fall Conference, September 27-29, 2012, Philadelphia, PA
- Pasquire, C. Gibb, A. and Blismas, N. 2004. 'Off-Site Production: Evaluating the Drivers and Constraints' In: Bertelsen, S. & Formoso, C.T., 12th Annual Conference of the International Group for Lean Construction. Helsingør, Denmark, 3-5 Aug 2004.
- Tong, L. and Mouritz, A. 2002. *3d Fibre reinforced polymer composites*. Boston: Elsevier

ENDNOTES

ⁱ <http://gramaziokohler.arch.ethz.ch/web/e/forschung/135.html>

ⁱⁱ <http://www.architectureanddesign.com.au/news/revolution-for-prefab-homes-moving-digital-fabrica>

Educational buildings and their potential to become net-zero energy buildings

Aydin Tabrizi¹, Paola Sanguinetti¹

¹University of Kansas, Lawrence, KS

ABSTRACT: A Net Zero Energy Building (NZEB) generates at least as much renewable energy on-site as it consumes in a given year. This study compares three real world educational buildings to become NZEB. Each case study consists of: (1) an energy model; (2) CFD model and (3) a cost model. Three performance criteria are considered: net zero energy (NZE), occupant comfort level and cost-benefit analysis. Energy consumption and generation are quantified using zonal models. Computational fluid dynamics (CFD) modeling is used to deal with problems associated with the thermal environment and the performance of building façade regarding the natural ventilation and building energy use. Scenarios are explored to identify the optimal NZEB with consideration of indoor comfort level and cost.

The results present options to achieve NZEB in educational buildings based on the location, climate and size of the structures. The nature of educational buildings and variability in the operation schedule provide opportunities to reduce the operation cost and to generate energy onsite while saving energy without deteriorating the comfort level of occupants in each case.

KEYWORDS: Educational Buildings; Net-Zero Energy Building; Life Cycle Costing; Computer Fluid Dynamics; Double Skin Façade

INTRODUCTION

In the United States, Commercial buildings account for one-fifth of U.S. energy consumption, with office space, retail space, and educational facilities representing the main part of commercial sector energy consumption. Educational buildings consume 614 trillion Btu of combined site electricity, natural gas, fuel oil, and district steam or hot water and they rank as the third highest category of energy consumers of all the commercial building types accounting for 12% of all energy used in commercial buildings.

Various programs to improve the energy and environmental quality of educational buildings have been applied. The Bright schools program is a California energy commission program, which offers specific services to help people to renovate or build new energy efficient school buildings. The green school project is a program developed from the Alliance to save energy, which aims at improving the energy and environmental efficiency of existing school buildings. Energy smart schools is a program of the Department of Energy and its Rebuild America program which mainly aims at offering school training workshops, publications, recognition, direct technical assistance and financing options, in order to improve educational buildings energy efficiency. In order to reduce the energy consumption of the commercial building sector with specific emphasis on educational buildings, the Department of Energy (DOE) has established the Commercial Building Initiative (CBI), a goal to create technologies and design approaches that lead to marketable NZEB by 2025. This goal calls for the increased production of clean renewable fuels and increased efficiency of products, buildings, and vehicles.



Significant policy action towards the promotion of energy-efficiency and on site renewable energy has been developed all around the world with different levels of intensity and structure. Actions such as the development of thermal regulations for buildings or the promotion of passive solar architecture are gaining momentum in current practices. Recently, the Net-Zero Energy Building (NZEB) concept started to appear in the literature as the optimum option for a very energy-efficient educational building. For a NZEB educational facility, a zero energy balance is required on an annual basis. The NZEB must have local systems that produce and export energy carriers into the grids, and make tradeoffs in its operation schedule, to achieve the annual balance.

1.0 EVALUATION OF THREE LEED-RATED EDUCATIONAL BUILDINGS

This paper explores how LEED-rated educational facilities could be retrofitted and their operational modified to achieve the NZEB standard. Three cases studies were selected because of the climatic location, structural type, LEED certification rating and functional similarities to evaluate the potential of NZEB

concept. Table 1 presents the information related to three educational buildings.

Table 1: Description for two LEED- rated education buildings.

	Building 1:	Building 2:	Building 3:
	Center for Design Research (CDR)	The Forum	Richard Klarcheck Information Commons
			
Climatic Zone	Humid Continental	Humid Continental	Humid Continental
Built Year	2011	2014	2007
Area (m ² / ft ²)	182/1961	242/2600	6410/69000
Building Type	Educational	Educational	Educational
Construction Type	As-Built	As-Designed	As-Built
Sustainability Level	LEED Platinum	LEED Platinum	LEED Silver
Energy Consumption Control	High Efficiency Glazing; Green Wall; Green Roof; HVAC Control	Double Skin Façade; Green Wall; HVAC Control	Double Skin Façade; Green Roof; HVAC Control
Energy Generation	PV Panels; Wind Turbine	PV Panels	N/A
Number of PV Panels	20	60	N/A

The first educational building, the Center for Design Research (CDR), is an existing research facility with several sustainable systems, including features such as rainwater collection and reuse, a living wall, real-time display of energy usage, a wind turbine, solar collectors, electric vehicle charging stations, and a green roof. High efficiency windows were used to eliminate glare effects and reduce solar heat gain during the summer months and heat loss during the winter months.

The second educational building, the Forum, is a building auditorium addition. The building incorporates both passive and active sustainable systems with intention to achieve LEED Platinum certification. A living wall with vegetation is used to purify the air in the auditorium space; a water harvesting system is to route precipitation to a cistern; and PV panels on the roof are to generate energy on site. A double skin façade (DSF) system mediates the heat transfer between the exterior and interior of the building depending on the time of the year. Vertical louvers control the amount of light and solar gain entering the space.

The third educational building is a library annex building. The Information Commons (IC) is LEED silver certified and employs a number of technologies that provide Loyola University with a computer center, classrooms and meeting spaces. The building features include a double skin façade allowing passive management of heat flow and natural ventilation throughout the year. Spanning within this façade is a mechanically operable blind that adjusts daylight levels and heat transmittance from the sun. Radiant concrete slab ceilings provide thermal mass to cool in the summer and heat in the winter. A green roof works to absorb rainwater and relieve some of the runoff into Lake Michigan.

As part of the case studies, data of the building's real energy consumption and the amount of energy generation by the PV renewable systems were collected and measured at first. Then modeling, simulation and output aggregation were conducted to quantify the energy consumption by the building facilities. After that the developed scenarios were evaluated to test parametric variations of renewable systems and building operation schedules. Lastly, the scenarios were evaluated to test the performance and efficiency level of the façade. In the meantime, the results were analyzed to give recommendations about the optimization of buildings performance and consideration of new factors for building performance enhancement or as the modification to the renewable systems.

Building performance was quantified using data measurements collected for the renewable energy sources on site. A base case model was generated to compare to the real building data. The buildings were simulated in the BIM software and the energy consumption of the buildings were quantified taking into account the energy produced by renewable systems. The building models were exported into energy modeling tool to analyze the building's energy performance.

The energy consumed in operation and the energy generated by the renewables was calculated for each case study as the base case. A set of alternative scenarios were developed and analyzed a part of a retrofit plan. Figure 1 shows the research procedure and the approach to analyze the facilities, evaluate scenarios, and facilitate the decision-making process toward the most optimum retrofit plan.

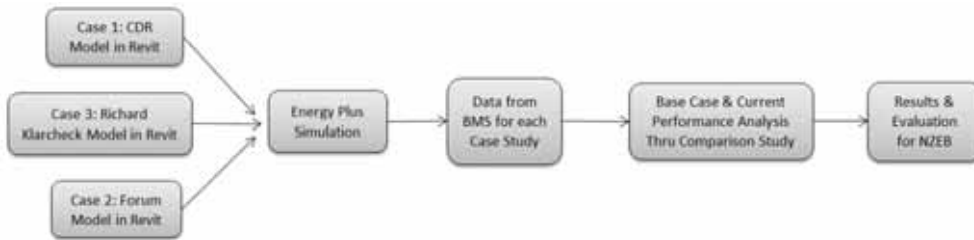

Figure 1: Energy data procedure.

2.0 ENERGY QUANTIFICATION

Each building was modeled is simulated in Revit Architecture, a Building Information Modeling tool. The analytical volumes were verified and each model was exported as a gbXML file into Green Building Studio™ and Ecotect™ (Table 2). These tools were used to specify operational schedules and weather data, to be exported as an Input Data File (IDF) into EnergyPlus, the U.S. Department of Energy tools for comprehensive simulation of the building envelope, fenestration, HVAC systems, daylighting and renewable energy components. The EnergyPlus IDF editor was used to verify the geometry and explore scenarios to achieve a balance between the predicted energy consumption and energy generation.

Table 2: BIM model for energy simulation and occupant comfort analysis.

	Building 1: Center for Design Research (CDR)	Building 2: The Forum	Building 3: Richard Klarcheck Information Commons
BIM Model, Zoning/Space Analysis			

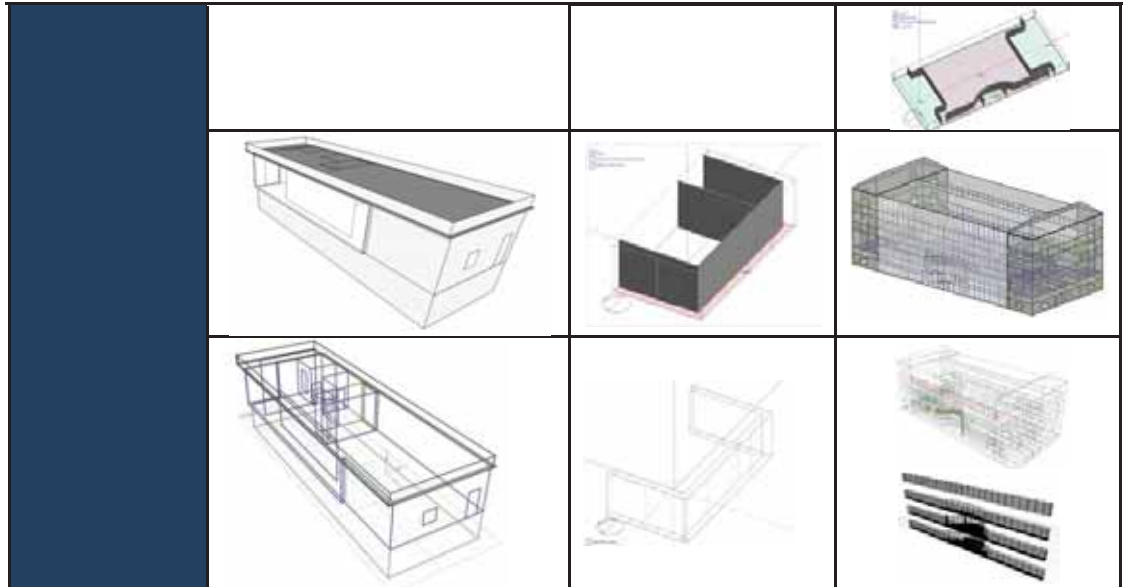

2.1 Quantification of the base case

For each educational building, a base case model is generated. The monthly cost of energy is calculated including the savings produced by photovoltaic (PV) panels installed on the roof. The quantification of each base case takes into account the installation cost of PV systems on the rooftop, with variations based on building features.

2.1.1 CDR base case

The CDR base case model is calibrated using energy data measurements collected for two years. The facility operation schedule was obtained in consultation with the facility manager and used as an input for energy analysis and cost evaluation. The facility is occupied during the week and weekends and consumes energy 24 hours every day for lighting, plug loads and HVAC control. Table 4 shows the monthly energy cost for this building. The cost of energy use in this building averages USD 893/month, USD 10,712/year or ₱ 46/ft².

The CDR roof surface measures 23.12 meter X 7.88 meter (75.86 ft. X 25.85 ft.) and PV types (250 W_p) are currently installed. The PV panel size is 165.1 X 101.6 cm (65 X 40 inches) and 20 PV panels occupy 17% of the roof surface. The cost for installation of each PV panel is estimated to be USD 498.69 and the overall installation for 20 panels is USD 9,974.

2.1.2 Forum base case

For the Forum base case model, it was assumed that the building is in operation during the weekdays and weekends. The energy consumption due to operation of a double skin façade is analysed. The cost of energy use in this building each month is USD 1462.27, for one year USD 17547.24 and ₱ 56/ft². The Forum monthly energy use is equal to 9208 kWh and based on Westar Energy definition, this building can be categorized under small general service building type.

The cost analysis for the installation of the PV panels to generate energy is according to the national renewable energy laboratory (NREL), where the median installed price of PV systems is USD 5.30/W for residential and small commercial systems smaller than 10 kilowatts (kW) in size and USD 4.60/W for commercial systems of 100 kW in size. For systems larger than 10,000 kW generally the price ranges from USD 2.50/W to USD 4.00/W and this variability in pricing is due to the price difference across the states and various types of PV applications and system configurations. This building measures 242 m² (2600 ft²) and half of roof area is covered with PV panels based on building design. Therefore, considering the mean of USD 3/W for PV installation at this building, will result the total cost of USD 3659.

2.1.3 RKIC base case

Data from building management system shows that the building is in operation during the weekdays 24 hours except Fridays until 10 PM. For the weekends the building is in operation from 8 AM to 9 PM on

Saturdays and from 10 AM onward for Sundays (Table 3). It is important to note that the facility's 300 computers never go into sleep status. The facility's energy consumption was evaluated with the consideration of double skin façade influence for the summer and winter seasons. Two ventilation types were considered based on the building zoning and accumulated data from the building management system to estimate the energy consumption with the consideration of DSF: a) mixed ventilation (natural + mechanical) for lobby space and mechanical ventilation for the sides. The mixed ventilation uses the DSF cavity zone as a buffer to treat the air and ventilation load between the interior and exterior of the building. The building annual energy use is 1,362,772 kWh and based on Integrys Energy Group, this building can be categorized under high load factor electric rate building type. The cost of energy use is USD 21,401 each month and for one year is USD 256,812 and ₪ 31/ft².

Table 3: RKIC base case operation schedule.

	OCCUPANCY	OPERATION SCHEDULE HOURS				TEMPERATURE RE SET POINT (°F)	TEMPERATURE RE SET BACK (°F)	VENTILATION MODE
		Weekdays	Friday	Saturday	Sunday			
LOBBY/LIBRARY	Full Use (All Year)	00:00	00:00	08:00	10:00	Heating: 68° Cooling: 72°	Heating: 55° Cooling: 76°	VAV + outside air reset + mixed mode
		AM-11:00 PM	AM-10:00 PM	AM-09:00 PM	AM-00:00 AM			
OFFICE/CLASSROOM	Full Use (All Year)	08:00	08:00	Off	Off	Heating: 68° Cooling: 72°	Heating: 55° Cooling: 76°	VAV + outside air reset
		AM-05:00 PM	AM-05:00 PM					

2.2 Comparison of energy costs

The cost of energy consumption is comprised of different factors including: 1) customer charge, 2) energy charge, 3) demand charge, 4) fuel charge, 5) property tax surcharge, 6) transmission delivery charge, 7) environment cost recovery rider, 8) energy efficiency rider, 9) franchise fees, and 10) sales tax. In order to calculate the energy consumption cost in each building, the energy monthly cost for commercial and educational facilities were extracted from Westar Energy website for the state of Kansas based on sales tax for state and locally and from Integrys Energy Group for the state of Illinois. According to the US EIA, the cost of electricity for the commercial building at the state of Kansas is ₪ 10.5 per kWh and ₪ 8.88 per kWh for the state of Illinois. Table 4 compares the monthly for each base case.

Table 4: Base case monthly energy cost for CDR, the Forum and RKIC.

	Building 1: CDR	Building 2: Forum	Building 3: Richard Klarcheck IC
Energy Charge (Westar Energy & Integrys Energy Electric Companies)			
Customer Charge	20	20	250
Energy Charge (USD (\$) 0.013085 per kWh for all kWh)	74.59	74.59	17831.87
Energy Charge (\$)	152.73	420.44	17832
Demand Charge (\$ 11.61680 per kW for primary service)	339.75	339.75	11,616.89
Fuel Charge	175.95	175.95	
Transmission Charge	65.71	201.07	29757.49
Environmental Cost Recovery Rider	40.76	124.71	3580
Energy Efficiency Rider	9.12	27.89	732.10
Property Tax Surcharge	1.62	4.95	733.17
Sub Total (\$)	3.33	10.18	1507.23
	808.96	1324.95	19589.23

Franchise Fee	24.27	39.75	587.68
Sub Total (\$)	833.23	1364.7	19589.23
Sales Tax	51.24	83.93	1224.33
	8.33	13.65	587.68
Total Sales Tax	59.58	97.58	1812.00
Total Bill Monthly (\$)	892.8	1462.27	21401.23
Average Bill Monthly (\$/ft²)	0.46	0.56	0.31

3.0 Cost-benefit analysis & risk considerations for NZEB decision-making

For each educational building, two scenarios were evaluated to achieve NZEB by implementing energy improvement strategies. The scenarios involve the opportunity to extend the number of PV panels in buildings 1 and 2 and addition of PV panels in building 3 where PV panels do not exist in this facility base case design (Table 5). In conjunction with this modification, changes to operation schedules for each building's lighting, HVAC, and equipment use (plug loads) were evaluated in each case (Table 6). The flexibility in the buildings operation schedule is investigated especially during summer when classes are not in session and lower occupancy rates can be used in the calculation based on the available life safety codes upon the type of occupancy .

Due to these building operation modifications, the CDR performs during normal office hours (8:00 AM- 5:00 PM) annually except weekends; however, the Forum performs during normal office hours (8:00 AM- 5:00 PM) during the winter semester from Monday to Friday while classes are in session. During the summer semester, there are no activities other than weekly seminars for staff and group discussion once a week.

At RKIC, the main computer lab (core zone) is in operation during normal office hours (8:00 AM- 5:00 PM), however during the final exams at the month of December and May, the facility is in operation from 8:00 AM to midnight. On the weekends the facility is occupied from 10:00 AM to 3:00 PM during the semester session and it is mostly in low occupancy during the summer. For both cases the rooms on facility corner are in use for 8:00 AM to 5:00 PM for summer and winter semesters and are not occupied during the summer holidays. In the case of weekends, the rooms are not occupied for both summer and winter semester (Table 6). The impact of these strategies and the opportunity to reduce costs due to energy consumption are examined in the following sections and shown in Table 7.

Table 5: Base case and alternative scenarios for pv panels addition.

Area distribution of PV panels	Building 1: CDR			Building 2: Forum			Building 3: RKIC		
	Base Case	Scenario 1	Scenario 2	Base Case	Scenario 1	Scenario 2	Base Case	Scenario 1	Scenario 2
Roof	17%	34%	17%	41%	83%	100%	0%	61%	100%
South façade	0%	0%	17%	0%	0%	0%	0%	0%	0%

Table 6: Alternative scenarios for operation schedule change during summer and winter.

	Building 1: CDR		Building 2: Forum		Building 3: RKIC							
	Winter Semester	Summer Semester	Winter Semester	Summer Semester	Core Zone (Lobby)				Side Zone (Office)			
					Winter Semester	Summer Semester	Dec & May	Weekends	Winter Semester	Summer Semester	Weekends	
Occupancy (People)	90-120 People or 0.05-0.07/ft2		173 People or 0.07/ft2	26 People or 0.01/ft2	690 People or 0.02/ft2				178 People or 0.02/ft2			0
Operation Schedule Hours	8:00 AM 5:00 PM		8:00 AM 5:00 PM	9:00 AM 3:00 PM	8:00 AM 5:00 PM	8:00 AM 5:00 PM	8:00 AM 12:00 AM	10:00 AM 3:00 PM	8:00 AM 5:00 PM	8:00 AM 5:00 PM	No Occupancy	
Days per Week	5		5	1	7				5			0
Temperature Set Point (°F)	Cooling: 72° Heating: 68°		68°	Original: 72° Modified: 78°	68°	72°	Cooling: 72° Heating: 68°	Cooling: 76° Heating: 64°	68°	72°	Off	
Ventilation Mode	VAV + outside air reset + mixed mode+ open blind		VAV + outside air reset + mixed mode+ close blind		VAV with HR + outside air reset + mixed mode			Natural Ventilation	VAV with HR + outside air reset		Natural Ventilation	

3.1 CDR improvement scenarios results

The energy generated by the PV panels account for 4097 kWh/yr and the consumed energy by the building is 36111 kWh/yr. The PV panels energy generation will reduce the building energy use to 32014 kWh/yr which will reduce the base cost to USD 9497.6/yr with a net savings (NS) of USD 1215/yr. The simple payback period (SPBP) is the initial cost of the item divided by the annual cost savings. The SPBP for building base case is 8 years and 2 months and ROI of 12.2%. The amount of energy production does not categorize this building under NZEB definition and alternative scenarios are required to analyze for this criteria.

By modifying the CDR operation schedules the energy consumption is reduced from 36,111 kWh/yr to 29,166 kWh/yr or 19%. The average monthly cost of energy is reduced from USD 892.80/month to USD 839.63/month and for one year it will cost USD 10075.56.

3.1.1 Scenario 1

The generated energy by PV panels will increase from 4097 kWh/yr to 8333 or 51%. However, doubling the number of PV panels will increase the cost from USD 9,974 to USD 19,948. The PV panel's energy generation will reduce the building energy use to 20833 kWh/yr or 42% and according to new operation cost of USD 10075.56/yr and reduced cost to USD 7196.8/yr, the building energy cost will reduce USD 2878.7/yr. The initial SPBP of 8 years and 2 months (base case) will reduce to 6 years and 10 months with ROI increase from 12.2% to 14.4%.

3.1.2 Scenario 2

The generated energy by PV panels will increase from 4097 kWh/yr to 9722 kWh/yr or 58% and the PV panel's energy generation will reduce the building energy use to 19444 kWh/yr or 46%. According to new operation cost of 10075.56 \$/yr and reduced cost to 6717 \$/yr, the building energy cost will reduce USD 3358.6/yr. The initial SPBP of 8 years and 2 months will reduce to 5 years and 10 months with ROI increase from 12.2% to 16.8% and the numbers obtained in both scenarios justify the investment to achieve NZEB (Table 7).

3.2 Forum improvement scenarios results

The energy generated by the PV panels account for 21366 kWh/yr and the consumed energy by the building is 110496 kWh/yr. The PV panels energy generation will reduce the building energy use to 89130 kWh/yr and accordingly, it will reduce the energy cost of the building (NS) USD 3393/yr. Building base case SPBP will be 2 years and 3 months with ROI of 92.8% and the amount of energy production does not categorize this project under NZEB definition.

The application of passive strategies in case study 2 such as DSF to provide natural ventilation and modification of building operation schedule and temperature set point change will reduce the building energy consumption from 110496 kWh/yr to 53191.44 kWh/yr or 4432.62 kWh/month or 52%. This modification will reduce the building energy cost from USD 1462.27/month to USD 1023.56/month or USD 12,282.72/yr instead of USD 17547.24/yr.

3.2.1 Scenario 1

The generated energy by PV panels will increase from 21366 kWh/yr to 42732 kWh/yr or 50%. The associated increase of cost will be USD 7317 instead of USD 3659 initial cost of PV panels' installation where the PV panel's energy generation will reduce the building energy use to 10,459 kWh/yr or 91%. According to new operation cost of USD 12,282.72/yr and reduced cost to USD 2415/yr, the building energy cost will reduce USD 9,868/yr. The initial (base case) SPBP of 2 years and 3 months will reduce to 10 months with ROI increase from 92.8% to 134.9%.

3.2.2 Scenario 2

The generated energy by PV panels will increase from 21366 kWh/yr to 51246 kWh/yr or 58% and the associated increase of cost will be USD 10233 instead of USD 3659 initial cost. The PV panel's energy generation will reduce the building energy use to 1,954 kWh/yr or 98% which defines the building almost as near NZEB. According to new operation cost of USD 12,282.72/yr and reduced cost to USD 451/yr, the building energy cost will reduce USD 11,832/yr and the initial SPBP of 2 years and 3 months will reduce to 11 months with ROI increase from 92.8% to 115.6% (Table 7).

3.3 RKIC improvement scenarios results

The building annual energy use is 1,362,772 kWh or 113,564 kWh/month. The modification of building operation schedule, temperature set point and consideration of natural ventilation influence with the mixed mode ventilation of DSF will reduce the energy use to 789,700 kWh per year or 65,808 kWh/month. This change will reduce the building energy cost almost 50% from USD 21,401/month to 12,516/month or USD 150,192 per year (¢ 18/ft²) instead of USD 256,812 per year (¢ 31/ft²).

3.3.1 Scenario 1

The installation of PV panels will generate 223,416.5 kWh/yr of energy and with consideration of USD 4.60/W for commercial systems of 100 kW in size , it will cost USD 563,132. The energy offset by the PV panels will reduce the building energy use from 789,700 kWh/yr to 566,283.5 kWh/yr and associated cost will reduce from USD 150,192/yr to USD 108,636/yr. The difference in the added cost of USD 563.132 of PV panels' addition and reduction of USD 106,620 due to the building schedule modification will cause USD 456,512 extra cost. However, the USD 41,556 saving due to the PV panels energy generation plus USD 106,620 (USD 148,176) saving each year, will cause the PV panels cost to be paid off in 3 years and 6 months (simple payback period of 3.5 years).

3.3.2 Scenario 2

The installation of PV panels will generate 365,821.25 kWh/yr of energy and with consideration of USD 4.60/W for commercial systems of 100 kW in size , it will cost USD 922,070. The energy offset by the PV panels will reduce the building energy use from 789,700 kWh/yr to 423,878.75 kWh/yr and associated cost will reduce from USD 150,192/yr to USD 82,140/yr. The difference in the added cost of USD 922,070 of PV panels' addition and reduction of USD 106,620 due to the building schedule modification will cause USD 815,450 extra cost. However, the USD 68,052 saving due to the PV panels energy generation plus USD 106,620 (USD 174672) saving each year, will cause the PV panels cost to be paid off in 5 years (simple payback period of 5 years) (Table 7).

Table 7: Cost-Benefit Analysis for NZEB Decision-Making

	Building 1: CDR			Building 2: Forum			Building 3: RKIC		
	Base Case	Scenario 1	Scenario 2	Base Case	Scenario 1	Scenario 2	Base Case	Scenario 1	Scenario 2
Energy Consumption (kWh/yr)	36111	29166	29166	110496	53191.44	53191.44	1,362,772	789700	789700
Energy Generation (kWh/yr)	4097	8333	9722	21366	42732	51246	0	223416.5	365,821.25
Cost (\$/month)	892.8	839.63	839.63	1462.27	1023.56	1023.56	21401	12516	12516
Total cost (\$)	9974	19948	19948	3659	7317	10233	256812	150192	82140
Building Energy Use (kWh/yr)	20833	9444	9444	10459	1954	1954	1,362,772	566283.5	423878.75
Simple Pay Back Period (SPBP)	8 years and 2 months	6 years and 10 months	5 years and 10 months	2 years and 3 months	10 months	11 months	N/A	3 years and 6 months	5 years



4.0 GLAZED FAÇADE & DSF THERMAL ANALYSIS VIA COMPUTER FLUID DYNAMICS

Application of new types of facade is necessary for more environmental friendly and energy efficient building design. However, there is a limited research of double skin façade and solely glazed covered façade concept performance at humid continental cities such as Lawrence, KS and Chicago, IL due to the focus of DSF Studies to the colder and more temperate climates of central Europe. In addition, available papers mostly describe DSF concept for energy efficiency through principles without any comprehensive experimental results .

4.1 Stack pressure (Thermal Buoyancy) in naturally ventilated façades

Buoyancy-driven ventilation is prevalent in many naturally ventilated buildings, with air flow caused by pressure differences across the building envelope. With this type of ventilation the pressure differences are due to air density differences, which in turn are due to temperature differences . It is the magnitude of these temperature and resulting pressure differences, as well as the building-opening characteristics that determine the magnitude of the buoyancy airflow. In stack-driven ventilation, height is increased and therefore the pressure difference between an inlet and outlet is increased. Above or below the neutral pressure level (NPL), airflow and direction can be determined; it is always from the higher-pressure region to the area of lower pressure. In other words, a temperature difference between the inlet and outlet can enhance the effects of buoyancy-driven ventilation. When the inside air temperature is greater than the outside air temperature, air enters through openings in the lower part of the building and escapes through openings at a higher level. Calculation of stack pressure is based on the temperature difference between the two air masses and the vertical spacing between the openings . When natural ventilation is used in a buoyancy-driven case, the airflow is not assisted by forced air from wind or mechanical systems .

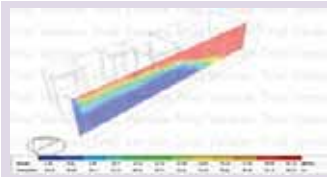
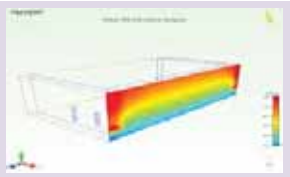
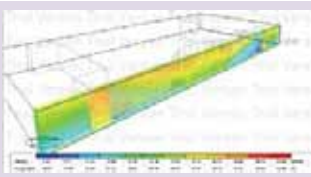
Table 8: Natural ventilation heat transfer through the façade.

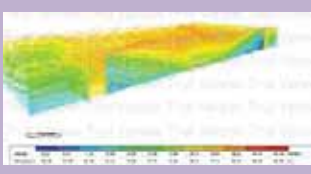
Building 1:	Building 2:	Building 3:
Center for Design Research (CDR)	The Forum	Richard Klarcheck Information Commons
		
		

4.2 Three case studies CFD analysis

The natural ventilation performance in DSF zone of case studies 2 and 3 and external glazing layer in thermal heat transfer through the building façade are presented in Table 8. Buoyancy driven flows predicted using space temperature calculated with 1000 iterations between airflow and thermal calculations. Through analysis, it was discovered that thermal buoyancy in the cavity was great enough resulting in warmed return air extracted from the space from the top of façade due to the Ventury effect . In all three cases, the stack air temperature increased towards the top of the façade in a fairly linear progression. Therefore, the findings show the efficiency of DSF in reducing the energy use by mechanical systems at DSF zone and necessity of façade reinforcement in the case of single layer glazing for thermal control of the indoor environment.

5.0 DISCUSSION

Three LEED-rated educational buildings feasibility to meet the NZEB energy efficiency were evaluated in this study. The costs of alternative energy improvements strategies are compared to a base case to determine if future operational savings justify the higher initial investments of additional PV panels to each

building. The influence of natural ventilation and reduction in building energy use with consideration of new types of façade such as single layered glazed façade and double skin façade were evaluated through computer fluid dynamics.

The initial energy use in three building differs significantly and it can be related to the structure, building area, building operation schedule and glazing type/area in each case. All cases justify the initial investment in the case of PV panels increase and reduction of buildings energy use by through building operation schedule modification. In building 1 (CDR), the SPBP reduces significantly from 8 years-2 months to 6 years-10 months and 5 years-10 months in each scenario respectively. Similarly in building 2 (Forum), the SPBP reduces from 2 years-3 months to 10 months and 11 months respectively. In building 3 (RKIC), the facility with sole high energy consumption, generates energy through installation of PV panels with SPBP of 3.5 years and 5 years respectively (Figure 2). The application of scenario 2 (17% roof-17% south façade) in building 1 reduce the SPBP significantly in comparison to scenario 1 in the same building and it can be discussed as an interoperability between energy reduction factors and cost benefits (Figure 3). However, in the 2nd and 3rd building, the increase of PV panel's number and modification of building energy use in scenario 2 influences the SPBP negatively in comparison to scenario 1. This can be discussed as the importance of correlation between cost benefits and energy savings where despite the reduction in energy amount, the SPBP increases. The application of scenario 2 in 2nd and 3rd buildings presents the lack of interoperability between environmental issues and economic aspect and demonstrates the importance of further research to create the link between economic and environmental aspects to establish the basis of sustainability concept for NZEB.

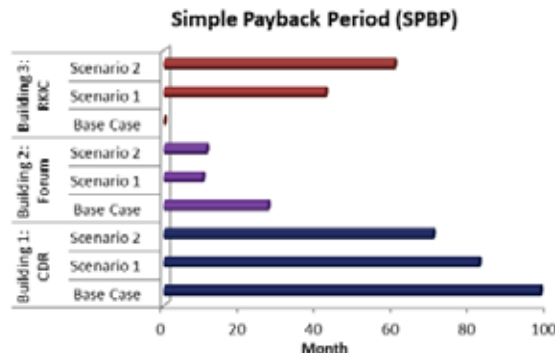

Figure 2: SPBP fluctuation in each case.

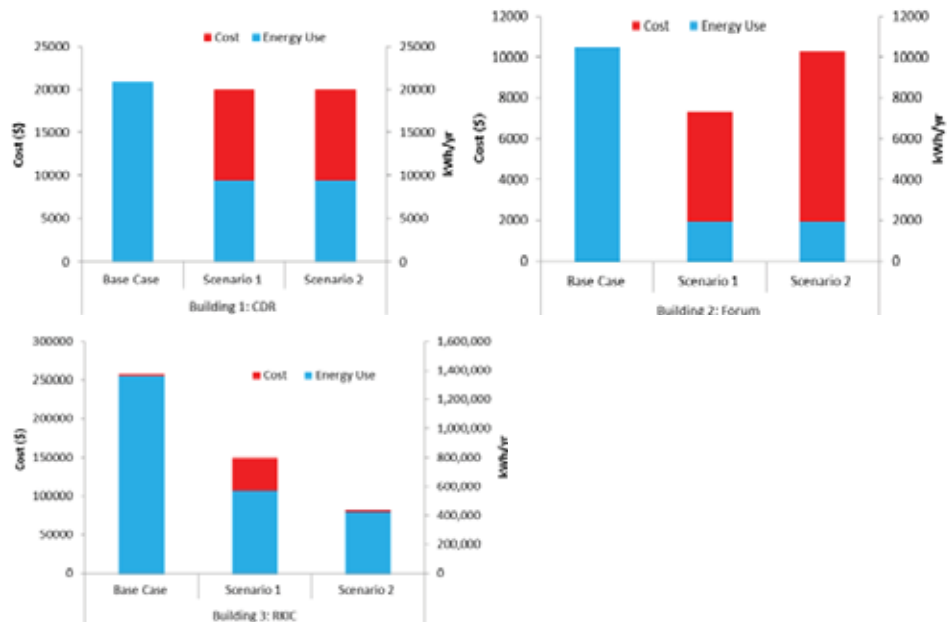

Figure 3: Energy use versus cost in each case.

The results obtained in this study, clarify the benefits of PV panels installation in order to generate energy and compensate for building energy use. However, the cost benefit analysis of PV panels contradicts the results obtained from energy analysis where the SPBP increases after installation of further PV panels in the 2nd and 3rd buildings. This observation highlights the importance of cost-benefit analysis for renewable energy systems such as PV panels to evaluate their adequacy in each project both environmentally and economically and clarifies the requirement of further research. Therefore, it is required to evaluate the optimum percentage of PV panels in every project to compensate for energy consumption while considering the life cycle cost of project and it is recommended to reduce the energy use in the building by modifying the building energy use first before consideration of PV panels installation or addition onsite.

The CFD analysis in 2nd and 3rd building presents the expected performance of double skin façade for the purpose of natural ventilation. In both cases, the cold air inlet from façade bottom entrance warms up by the occupant use and existing equipment and the hot air leaves the façade cavity zone at the upper level. However, the further research regarding the size of perforation at bottom and top of DSF cavity zone and the required area to compensate for mechanical ventilation through DSF natural ventilation effect is required in future research. In case 1, the CFD analysis presents the thermal heat circulation around the single layer glazed wall and indoor environment. As expected, the glazing surface creates a cold spot zone on the building exterior in comparison to indoor heated environment. The research on the glazing insulation and the design of shading devices to fulfill occupant comfort level around the glazing surface require future research.

6.0 CONCLUSION

In this paper, the operational performance of three LEED-rated educational buildings was evaluated using the Cost-benefit analysis and CFD simulation to evaluate and compare strategies to achieve Net Zero Energy Building (NZEB). The application of PV panels was evaluated in relation to building cost, energy performance and simple energy payback period (SPBP). The results in each case study are promising and present the possibility of achieving NZEB in educational buildings considering the location, climate and size of the structures. In the meantime, the nature of buildings and flexibility in the operation schedule during each semester (winter, summer) provides the opportunity to reduce the operation cost and to generate energy onsite while saving energy without deteriorating the comfort level of occupants in each case.

However, studies by show the vulnerability of PV panels to on-site factors such as deposition of dust, bird-droppings, water-stains (salts), and cracked individual cells, causing significant degradation in the efficiency of solar panels. Also, the study by the National Renewable Energy Laboratory (NREL) on 2000 solar panels present the decrease in the performance of PV modules over time with higher degradation rate in the first year upon initial exposure to light. Therefore, the risk of degradation over time indicates an uncertain state with possibility of financial loss and it requires further research in the future for the energy generation potential in the NZE buildings.

In conclusion, LEED-certified buildings are good candidates to become NZEB due to their nature by having larger spaces to accommodate the installation of renewable energies such as PV panels to generate energy and flexibility in their schedule to reduce energy consumption for HVAC, plug loads and lighting use.

Finally, the findings show this building type has great capacity to achieve the NZEB standard because of the variability in the occupancy and operation of the building, and the possibility to maximize the deployment of renewable energy systems.

REFERENCE

- Butala, Vincenc, and Peter Novak. "Energy Consumption and Potential Energy Savings in Old School Buildings." *Energy and buildings* 29, no. 3 (1999): 241-46.
- Data, Financial. "Integrays Energy Group Inc." (2014).
- Dickson, Austin, Blair Garvey, and Michelle Larson. "Green Energy Options for Sustainable Local Economic Development: Policy, Financing and Strategies for Green Energy." *Georgia institute of technology, city and regional planning program, planning local economic development* (2007).
- Energy, Westar, and Inc Settlement. "Epa." 2010.
- Feldman, D, G Barbose, R Margolis, R Wiser, N Darghouth, and A Goodrich. "Photovoltaic (Pv) Pricing Trends: Historical, Recent, and near-Term Projections." National Renewable Energy Laboratory (NREL), Golden, CO., 2012.
- Feldman, David. "Photovoltaic (Pv) Pricing Trends: Historical, Recent, and near-Term Projections." (2014).
- Hottel, Hoyt, and B Woertz. "Performance of Flat-Plate Solar-Heat Collectors." *Trans. ASME (Am. Soc. Mech. Eng.);(United States)* 64 (1942).
- Hunt, GR, and PP Linden. "The Fluid Mechanics of Natural Ventilation—Displacement Ventilation by Buoyancy-Driven Flows Assisted by Wind." *Building and Environment* 34, no. 6 (1999): 707-20.
- Independence, Energy. "Security Act (Eisa). 2007. Energy Independence and Security Act of 2007." *Public Law* (110-40).

- Jiang, Jess. "The Price of Electricity in Your State." *Planet Money*. <http://www.npr.org/blogs/money/2011/10/27/141766341/the-price-of-electricity-in-your-state> (2011).
- Jiang, Yi, and Qingyan Chen. "Buoyancy-Driven Single-Sided Natural Ventilation in Buildings with Large Openings." *International Journal of Heat and Mass Transfer* 46, no. 6 (2003): 973-88.
- Lin, YJP, and PF Linden. "Buoyancy-Driven Ventilation between Two Chambers." *Journal of Fluid Mechanics* 463 (2002): 293-312.
- Milke, James A, and Tony C Caro. "A Survey of Occupant Load Factors in Contemporary Office Buildings." *Journal of Fire Protection Engineering* 8, no. 4 (1996): 169-82.
- Olson, Stephen L, and Shana Kellum. "The Impact of Sustainable Buildings on Educational Achievements in K-12 Schools." *Leonardo* 2 (2003).
- Pappas, Alexandra, and Zhiqiang Zhai. "Numerical Investigation on Thermal Performance and Correlations of Double Skin Facade with Buoyancy-Driven Airflow." *Energy and buildings* 40, no. 4 (2008): 466-75.
- Pless, Shanti, and P Torcellini. "Energy Performance Evaluation of a Low-Energy Academic Building: Preprint." National Renewable Energy Laboratory (NREL), Golden, CO., 2005.
- Saelens, Dirk, Jan Carmeliet, and Hugo Hens. "Energy Performance Assessment of Multiple-Skin Facades." *HVAC&R Research* 9, no. 2 (2003): 167-85.
- Tabrizi, Aydin, and Paola Sanguinetti. "Case Study: Evaluation of Renewable Energy Strategies Using Building Information Modeling and Energy Simulation." *International Journal of 3-D Information Modeling (IJ3DIM)* 2, no. 4 (2013): 25-37.
- Tabrizi, Aydin, , and Paola Sanguinetti. "Nzeb Enhancement for a Leed Platinum Educational Facility". *Journal of Civil Engineering and Architecture* (2014).
- Wagner, Andreas, Thomas Lützkendorf, Karsten Voss, Guido Spars, Anton Maas, and Sebastian Herkel. "Performance Analysis of Commercial Buildings—Results and Experiences from the German Demonstration Program 'Energy Optimized Building (Enob)'." *Energy and Buildings* 68 (2014): 634-38.
- Zöllner, A, ERF Winter, and R Viskanta. "Experimental Studies of Combined Heat Transfer in Turbulent Mixed Convection Fluid Flows in Double-Skin-Facades." *International Journal of Heat and Mass Transfer* 45, no. 22 (2002): 4401-08.

**ENVIRONMENTAL, ENERGY AND
BUILDING PERFORMANCE FACTORS**

A decision-making framework to optimize roof functionality in the design of sustainable buildings

Nooshafarin Mohammadzadeh¹, Soolyeon Cho¹, Nikita Jathan²

¹BETlab, College of Design, NC State University, Raleigh, North Carolina

²Virginia Commonwealth University, Richmond, Virginia

ABSTRACT: The decisions made in early design stages contribute greatly to the energy performance of a building in various aspects. The roof, as part of the envelope, is one of the most significant factors in the development of sustainable buildings, however, there is a lack of integrated roof design guidance to better inform architects and building practitioners. Therefore, a rational and lucid approach that manages tradeoffs in order to achieve optimal solutions to designing and developing a more energy efficient and sustainable roof is imperative. Applying the framework, the roof area can be better applied for various purposes during different energy design and sustainable development stages. This research encompasses the method used to develop a roof design assistant framework or “RoofConsultant” that can be utilized to optimize roof functionality in design and development of sustainable buildings. In the course of the literature review and research process, a comprehensive knowledge and information database is developed and categorized based on seven key roof functions. Appropriate strategies within these functions are addressed with regard to eight US climate zones. Energy codes, standards, and guidelines are used to develop boundaries for the application of roof design strategies in different climates and locations. Through this comprehensive approach, RoofConsultant aims to be an interactive tool for designers that can lead to more effective sustainable development of roofs.

KEYWORDS: Roof Design, Integrated Roof, Sustainable Building, Net Zero Energy Building, Energy Efficiency

INTRODUCTION

Major design decisions regarding building sustainability are made primarily by architects and designers in the early design stages. Changing design parameters like form, orientation, and envelope configuration leads to buildings of higher quality design that can use around 40% less energy than a lower quality design (Wang, 2006). In the building envelope, the roof is particularly an important area in the conceptual stage of building design. Various roof design strategies have been developed to improve energy efficiency of buildings, generate energy, and increase water retention and waterproofing capability.

Currently, there are few useful tools or programs that help design sustainable roofs. Some programs can provide designers and consultants with valuable information in practices. Three programs (Climate Consultant, RoofNav, and RoofPoint) are frequently used by building practitioners to analyze various aspects in roof design. Each of the three has its target areas of analysis.

Climate Consultant, developed by UCLA (Milne 2007), graphically presents climate information (including temperature, humidity, solar radiation, and others such as wind and precipitation), along with guidelines and strategies for climate-based design decisions in specific locations. It is not specifically used for roof projects. RoofNav is a large materials database that provides roof professionals with Factory Mutual (FM) certified material options and step-by-step guidance on how to identify, configure, and install different roofing assemblies and components that comply with FM roofing standards.

RoofPoint (CEIR 2012) rates roof performance in terms of energy efficiency and renewable energy generation. It uses a calculator whose primary function is to measure the energy and environmental characteristics of roofing systems in commercial and institutional buildings and compare different roof system solutions with regard to energy and environmental impacts (Hoff and Resort 2013). RoofPoint is a rating tool that focuses on end results and practices; it uses five functional areas of the roof, and provides 23 total sustainable strategies. Quantitative outcomes provide results in benchmarking for better practices in energy efficiency and renewable energy systems applications.

A new tool, RoofConsultant, is proposed in this paper. It focuses on design aspects different from the information that existing programs like Green Building Studio, Vasari, or Ecotect can provide; these tools use quantitative analysis in building energy calculations or simulations. RoofConsultant uses a qualitative

approach for making efficient design decisions, providing options and sustainable measures for designers and architects to consider.

The target area of RoofConsultant, as mentioned, is on early design phases. Designers do not usually pay much attention to the roof area in the design process, but it has a significant role in developing sustainable buildings, or achieving Net Zero Energy Buildings (NZEBS). RoofConsultant aims to provide design strategies that can help achieve goals of energy efficiency and renewable energy generation, resulting in more sustainable buildings. The following section discusses the methodology of RoofConsultant and the contents.

1.0 METHODOLOGY

A compendium of strategies (or database of roof design strategies) is the basis to developing an interactive tool (RoofConsultant) that will be customized to give useful information for the user to make decisions for the design of sustainable roofs.

1.1. Framework

RoofConsultant is organized into three primary areas (i.e., roof functions, boundaries, and reality) representing the most important principles. Each of the three conceptual groups includes the contents as follows.

1. Roof Functions: key design parameters or sustainable strategies that should be considered in the early design phases.
2. Boundaries: specific code requirements and guidelines for particular climate conditions.
3. Reality: overarching concerns that need to be thought out since there are always issues about aesthetics (roof shape), implementation costs, and/or psychological aspects in a built environment (Fig. 1).

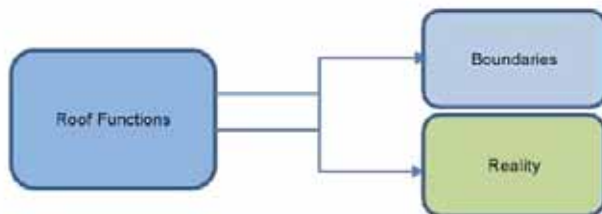

Figure 1: Three conceptual areas of RoofConsultant framework. Source: (Author 2015)

Roof functions

In order to recognize different energy and environmental outcomes, 15 strategies have been identified to have the most influence, based on the literature review. These systems are categorized in seven comprehensive functional areas, which were investigated in detail to develop specific design strategies: Energy efficiency, Energy generation, Daylighting, Equipment allocation, Rainwater collection, Waterproofing, and Recreation. The first three functional categories deal with energy issues more closely than the other four categories.

1.2.1. Energy efficiency

The roof has much potential for increasing the efficiency of energy use in a building system. This function addresses roof design strategies as a key influencer of building energy efficiency. The energy efficiency function consists of four strategies which have substantial impact on the energy use of buildings; these are green roof, cool roof, thermal insulation and thermal mass.

Green roof: Green roofs are considered to be effective strategies in energy efficiency design, and specifically appropriate for both winter heating energy reduction and summer cooling energy reduction. A green roof can improve stormwater management capability and urban air quality, and aid in reduction of the urban heat island effect, while also providing habitat for wildlife, and aesthetic appeal. Additionally, green roofs can extend roof life, improve acoustics, and enhance architectural interest and biodiversity (Dvorak and Volder 2010; Köhler et al. 2002; Niachou et al. 2001; Oberndorfer et al. 2007; Sailor 2008; Castleton et al. 2010).

Many studies have been conducted to investigate the potential building energy savings of green roofs. Some researchers investigated selecting efficient vegetated roofing systems for different climate conditions (Grant & Jones 2008). Alexandri and Jones developed a model to estimate the potential of reducing temperatures in nine cities by applying green roofs (Alexandri and Jones 2008). Other studies have

investigated microclimate impact of vegetation cover (not specifically green roof) up to a 1.3 oC reduction in a city's maximum temperature (Sailor 1995).

Cool Roof: A cool roof's first and foremost benefit is energy efficiency in building systems. By reducing the roof surface temperature, cooling loads are reduced, which gives energy and cost savings and reduced electrical grid strain from the reduction of peak cooling demands. Resultantly, cool roofs result in better air quality, reductions in carbon and power plant emissions, and mitigation of urban heat islands. Cool roofs also increase roof life and occupant comfort, and are easily implemented (Akbari et al. 2004, 2008; Berkeley Lab 2014; Bhatia et al. 2011; Bozonnet et al. 2011; Santamouris et al. 2011; Synnefa et al. 2007; Van Tijen and Cohen 2008).

Energy savings from using reflective materials to decrease temperatures have been investigated through actual measurements and simulation programs. Jo et al. reported that cool roof technology can result in building electricity consumption reduction of 1.5%-1.8% and 2.8%-3.4% using a 50% and 100% cool roof (Jo et al. 2010).

Thermal insulation: Thermal insulation can reduce the rate of heat transfer through conduction, convection, and radiation. It prevents heat from exiting or entering a space, keeping it at a more constant temperature, and gives energy savings, economic benefits, and environmental profits. Thermal insulation in roofing systems is an important factor in determining the thermal performance of buildings due to the direct exposure to radiation and outside environments (Al-Homoud and Mohammad 2005; Al-Jabri et al. 2005).

Thermal mass: Thermal mass is a property that enables materials to absorb and store thermal energy, and delay heat transfer from outdoor to indoor space or vice versa, and is significant in determining thermal performance of building envelopes, including roof surfaces. Thermal mass works well in commercial buildings by shifting peak summer loads to later in the day, closer to closing times. Energy demand is moved to an off-peak period, and peak temperatures, peak loads, and emissions are reduced (Baggs and Mortensen 2006; Kalogirou et al. 2002; Shaviv et al. 2001).

1.2.2. Energy generation

Energy generation systems can often be placed on the roof. An appropriate energy generation system can alleviate energy use and costs significantly. This function addresses the roof design as a key influencer of energy generation in buildings. Energy generation as a function in buildings consists of four strategies: solar power (PV systems), solar thermal, wind power, and biomass & bioelectricity.

Solar power: Solar photovoltaic systems convert light from the sun directly into electricity and generate pollution-free energy. They can be installed on the roof as well as on the wall of commercial buildings as a grid-connected photovoltaic (PV) application (Parida et al. 2011). Solar PV systems are commercially available and can be reliably effective depending on the climate zone of interest. Often, times of year with high cooling demands coincide with high available solar energy, which highlights the potential utility of this technology.

Solar thermal: Solar thermal systems use thermal energy to heat up water or air. This thermal energy can be used for various applications including providing hot water, heating and cooling of buildings and spaces, and generation of electric power (Kalogirou 2004).

Wind Power: Wind turbines hold potential to produce low-cost energy on the roof (Abohela et al. 2013). Wind energy is a green, indigenous power source that is permanently available, and can be stored when winds are low. Its cost is generally limited to installation of the wind turbine, and it can be a great resource in remote locations, such as in the mountains. This technology will play an important role in future energy generation, due to its technological maturity, good infrastructure, and relative cost competitiveness (Harbert et al. 2007; Mithraratne 2009).

Biomass & Bioelectricity: Biomass is biological material derived from living, or recently living organisms, from which heat energy is derived. Biomass is a promising renewable energy source as it can provide energy security in regions with a lack of fossil fuels, while also reducing the carbon emission level per unit of energy delivered (Field et al. 2008).

Bioelectricity is the generation of electric power potential or current produced by or within living organisms. Bioelectricity can be harnessed for power through plant-microbial fuel cells², (PMFCs), a new technology. PMFCs can also be developed to treat waste water and monitor pollutants (Deng et al. 2012).

1.2.3. Daylighting

Daylighting in buildings can significantly improve lighting quality. Proper sizing and design with suitable lighting control can save energy, by optimizing the size of apertures to control both illuminance level and annual energy performance (Heschong and McHugh 2000; Johnson et al. 1984). This function is categorized in three top lighting system examples: skylights, light pipes, and saw-tooth and roof monitors.

1.2.4. Equipment allocation

Roof areas in commercial buildings are frequently used to house HVAC systems such as Rooftop Air Handling Units (AHUs) and cooling towers. Placing the system on the roof results in less visibility than in other parts of the building, and placing loud equipment on the roof reduces volume at ground level.

1.2.5. Rain water collection

The rainwater collection function is included as water conservation issues become more important and prevalent in current times. Roofs comprise a significant percentage of impermeable areas, yielding substantial potential for rainwater collection. The application of an appropriate rainwater harvesting technology can utilize the rainwater as a valuable and necessary water resource (Villarreal and Dixon 2005).

1.2.6. Waterproofing

The waterproofing of the roof is of great concern in the roofing industries. An appropriate water roofing system can protect structure and interior content, extend structure lifetime, provide thermal comfort, and improve environmental quality by preventing mold. Roof coatings that meet energy requirements give additional benefits of cool roofing and air conditioning savings. Cooled roofs also do not experience temperature change stresses, giving reduced future maintenance due to thermal shock (NYC Environmental Protection 2012).

1.2.7. Recreation

Roofs can be used as a myriad of recreational spaces (plant roof, vegetation production, rooftop farming, restaurant, pool, etc). Physical characteristics of the roof surface, including slope, materials, and loading capacity, must be considered when designing for recreation. The benefits of many different kinds of roof functions can be reaped when designed intelligently.

1.3. Boundaries

The roof functions in the seven areas discussed are dependent upon certain circumstances such as different climate conditions and standards. This section presents important conditions that need to be considered at the time of roof design. While not all referenced sets of standards are dedicated to roof design, they contain useful information.

1.3.1. Climate Condition

The climate condition in which a building is situated is the one of the most important parameters to consider in efficient roof design. Code and standard requirements vary by climate region. According to IECC 2012, the US climate zones are divided into eight temperature oriented areas. USDOE's Pacific Northwest National Laboratory (PNL) identified sixteen representative cities in these areas. The sixteen cities were used here to specifically develop design strategies that work suitably for each location (Table 1).

Table 1: 16 cities of different climate zone in US. Source: (IECC 2012)

Climate Zone	Representative City
1A	Miami, Florida
2A	Houston, Texas
2B	Phoenix, Arizona
3A	Atlanta, Georgia
3B-Coast	Los Angeles, California
3B	Las Vegas, Nevada
3C	San Francisco, California
4A	Baltimore, Maryland
4B	Albuquerque, New Mexico
4C	Seattle, Washington
5A	Chicago, Illinois
5B	Boulder, Colorado
6A	Minneapolis, Minnesota
6B	Helena, Montana
7	Duluth, Minnesota
8	Fairbanks, Alaska

1.3.2. Codes, standards, and guidelines

Building codes, standards, and guidelines help building practitioners design and develop sustainable buildings. These documents were used in this study to provide important guides for the design of roof.

1. IECC-2012 (International Energy Conservation Code). This code is relevant to addressing the design of energy-efficient building envelopes, and the installation of energy efficient systems. Performance of materials and systems is emphasized.
2. ASHRAE Standard 90.1-2010 (American Society of Heating and Air-Conditioning Engineers). Standard 90.1 describes the minimum requirements for energy-efficient design in most buildings besides low-rise residential buildings, and covers system requirements in new and existing buildings. It is especially useful for engineers, and building system designers.
3. IgCC-2012 (International green Construction Code). The IgCC is the first model code that includes sustainability measures for the entire construction project, as well as its site, all the way from early design states to beyond certificate of occupancy. This code addresses holistic sustainability through energy efficiency, waste reduction, and healthy and community welfare.
4. ASHRAE AEDG 50% (Advanced Energy Design Guides). The Advanced Energy Design Guides offer recommendations for achieving 50% energy savings based on the minimum requirements outlined in Standard 90.1-2004. The Advanced Energy Design Guides offer steps to ultimately help achieve a net zero energy building.
5. ASHRAE Handbook fundamentals, 2009. This Handbook addresses basic principles and data pertinent to the HVAC&R industry.

1.3.3. Benchmarking

As mentioned earlier, there are some existing tools that can be used in benchmarking such as Climate Consultant, RoofPoint, and RoofNav. Additionally, the EIA's Commercial Building Energy Consumption Survey (CBECS) report was also referenced to show the typical energy consumption levels for different building types with the metric Energy Use Intensity (EUI).

Figure 2 shows the framework of RoofConsultant. This is an expanded version of Figure 1. The right column represent different roof functions and the left column represents the boundaries and reality aspects of each function. Each function on the right is related to the boundaries and reality section in the left column (Fig 2).

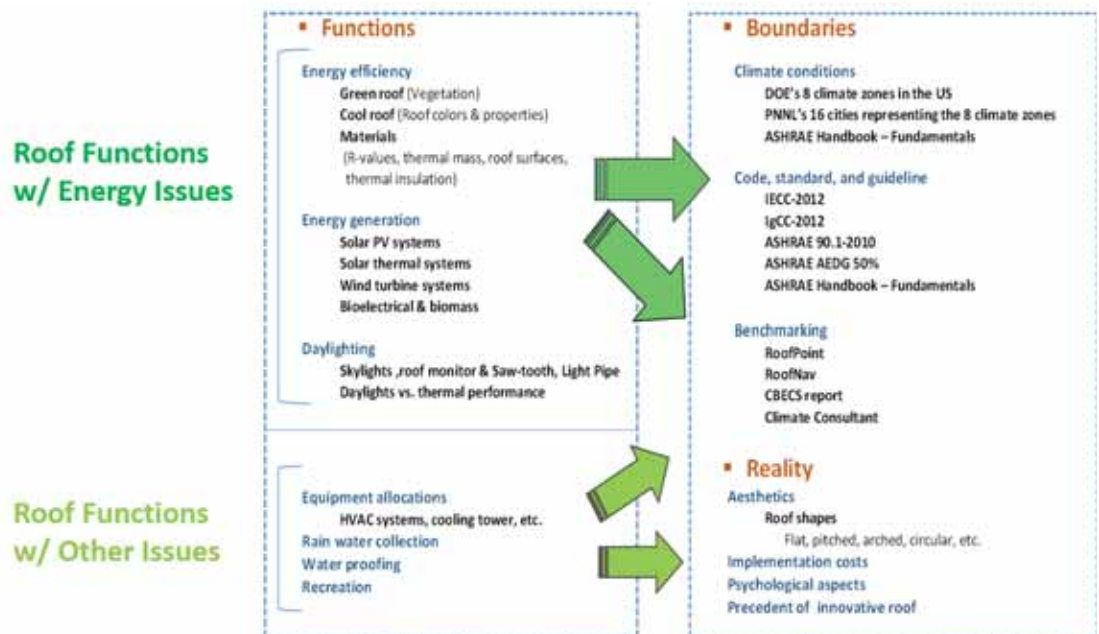

Figure 2: Framework of RoofConsultant. Source: (Author 2015)

1.4. Reality

The functions and boundaries have been determined in the framework; however, there are still important aspects that must be considered in the design process, known as reality. These are aesthetics (i.e., roof shapes), implementation costs, and potential psychological characteristics. These comprise the third of the three structural areas in the RoofConsultant framework.

2.0. COMPENDIUM OF STRATEGIES

After developing the compendium of strategies, a database is organized in an Excel spreadsheet. The information included in the spreadsheet is used as the information and data sources of the RoofConsultant tool (Fig 3).

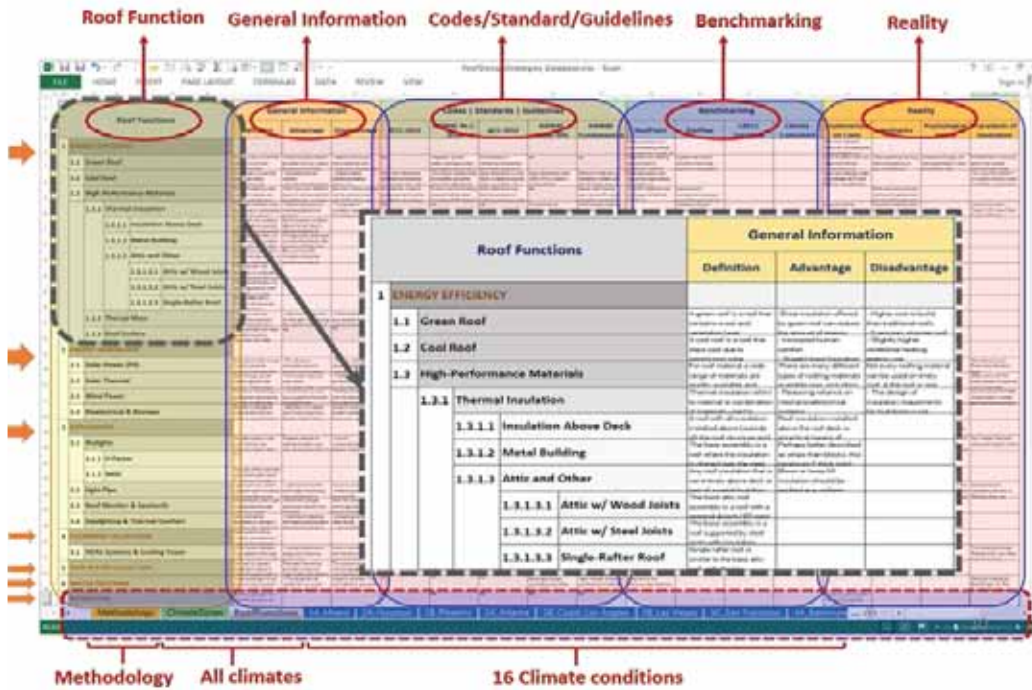

Figure 3: Compendium of strategies.

Each column corresponds with a discussed area of the framework. From left to right, column categories address roof functions, general information, codes and standards, benchmarking, and information relevant to the reality of implementation. The same structure is repeated for each of the 16 representative cities discussed above. Figure 4 shows a snap shot of the 16-category spreadsheet that includes individual roof design strategies for each city (explained in Figure 3.)



Figure 4: Roof design strategies for 16 different cities.

3.0. TOOL DEVELOPMENT

In order to better understand and use the provided information, we developed the tool. RoofConsultant uses an easy and affordable framework that can effectively help practitioners design roofing projects based on climate conditions. The tool development structure is presented in Figure 5. Python programming language is used for controllers of the framework. JavaScript and jQuery UI are used for interactive functionalities.

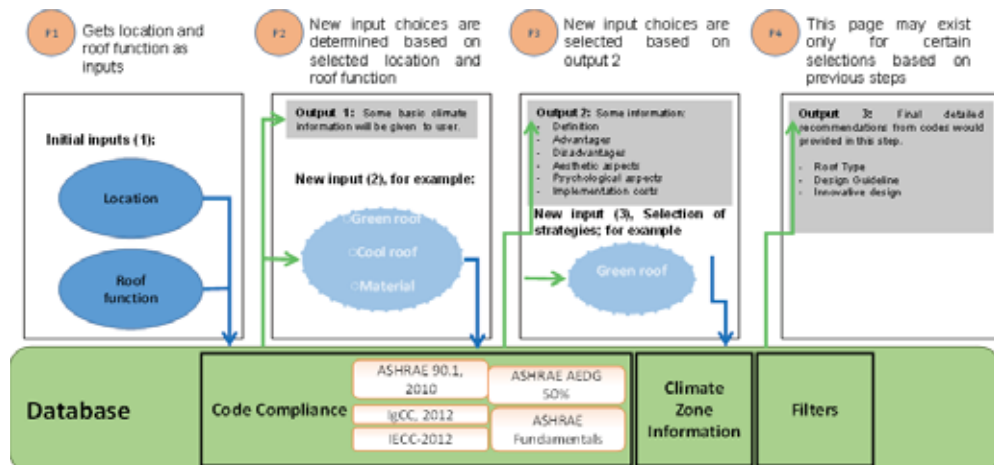

Figure 5: Tool development structure.

The user first inputs location and desired roof function, which dictate input choices to follow. The user can then select roof functions based on information outlining definitions, advantages, and disadvantages. After selecting a roof function, the user is provided information for implementation through codes, standards, benchmarking and reality aspects.

CONCLUSION

This paper presents the importance of effectively utilizing the roof area to achieve the goals of the 2030 Challenge or Carbon-Neutral by 2030. Seven key roof functions are evaluated for different climate zones in the US based on existing codes, standards and benchmarking. An information database was developed for the improvement of sustainable commercial roof design. This framework would be the basis to illustrate the potential value of each strategy in specific locations for future calculation. Next steps include further development of a number-based metric, which will be based on numerous simulations. Pre-simulated performance data will be used to provide quantitative, comparative guides to the users. Simulation technologies such as EnergyPlus, Radiance, OpenStudio etc., and field measurements will assist us in this analysis.

REFERENCES

Abohela, I., Hamza, N. and Dudek, S. 2013. Effect of roof shape, wind direction, building height and urban configuration on the energy yield and positioning of roof mounted wind turbines. Renewable Energy.

Akbari, H., Berdahl, P., Levinson, R., Wiel, R., Desjarlais, A., Miller, W. ... and Scruton, C. 2004. Cool colored materials for roofs. Proceedings of the ACEEE 2004 Summer Study on Energy Efficiency in Buildings Vol. 1.

Akbari, H. and Levinson, R. 2008. Evolution of cool-roof standards in the US. Advances in building energy research.

Al-Homoud, D. and Mohammad, S. 2005. Performance characteristics and practical applications of common building thermal insulation materials. Building and environment.

Al-Jabri, K. S., Hago, A. W., Al-Nuaimi, A. S. and Al-Saidy, A. H. 2005. Concrete blocks for thermal insulation in hot climate. Cement and Concrete Research.

Alexandri, E. and P. Jones. 2008. Temperature decreases in an urban canyon due to green walls and green roofs in diverse climates. Building and Environment.

Baggs, D. and Mortensen, N. 2006. Thermal mass in building design. Royal Australian Institute of Architects for the Australian Council of Building Design Professions Ltd.

Berkeley Lab. 2014. Cool Science: Cool Roofs. Retrieved from <http://heatisland.lbl.gov/coolscience/cool-science-cool-roofs>.

- Bhatia, A., Mathur, J. and Garg, V. 2011. Calibrated simulation for estimating energy savings by the use of cool roof in five Indian climatic zones. *Journal of Renewable and Sustainable Energy*.
- Bozonnet, E., Doya, M. and Allard, F. 2011. Cool roofs impact on building thermal response: A French case study. *Energy and Buildings*.
- Castleton, H. F., Stovin, V., Beck, S. B. M. and Davison, J. B. 2010. Green roofs; building energy savings and the potential for retrofit. *Energy and Buildings*.
- CEIR. 2012. RoofPoint Guideline for Environmentally Innovative Nonresidential Roofing. Center for Environmental Innovation in Roofing. 2012. Guideline for Environmentally Innovative Nonresidential Roofing. Washington, DC.
- Dvorak, B. and Volder, A. 2010. Green roof vegetation for North American ecoregions: a literature review. *Landscape and urban planning*.
- Deng, H., Chen, Z. and Zhao, F. 2012. Energy from plants and microorganisms: progress in plant-microbial fuel cells. *ChemSusChem*.
- Field, C., Campbell, J. and Lobell, D. 2008. Biomass energy: the scale of the potential resource. *Trends in Ecology & Evolution*.
- Grant, E. J. and Jones, J. R. 2008. A decision-making framework for vegetated roofing system selection. *Journal of Green Building*.
- Herbert, GM Joselin, Selvaraj Iniyar, E. Sreevalsan, and S. Rajapandian. 2007. A review of wind energy technologies. *Renewable and sustainable energy Reviews* 11, no. 6: 1117-1145.
- Heschong, Lisa, and Jonathan McHugh. 2000. Skylights: Calculating illumination levels and energy impacts. *Journal of the illuminating engineering society* 29, no. 1: 90-100.
- Hoff, J. L. and Resort, R. S. C. 2013. Measuring Energy and Environmental Impacts: A New Modeling Tool for Roofing Professionals. RCI 28th International Convention & Trade Show.
- Jo, J. H., Carlson, J. D., Golden, J. S. and Bryan, H. 2010. An integrated empirical and modeling methodology for analyzing solar reflective roof technologies on commercial buildings. *Building and Environment*.
- Johnson, R., Sullivan, R., Selkowitz, S., Nozaki, S., Conner, C. and Arasteh, D. 1984. Glazing energy performance and design optimization with daylighting. *Energy and Buildings*.
- Joselin Herbert, G. M., Iniyar, S., Sreevalsan, E. and Rajapandian, S. 2007. A review of wind energy technologies. *Renewable and sustainable energy Reviews*.
- Köhler, M., Schmidt, M., Grimme, F. W., Laar, M., de Assunção Paiva, V. L. and Tavares, S. 2002. Green roofs in temperate climates and in the hot-humid tropics—far beyond the aesthetics. *Environmental management and health*.
- Kalogirou, S. A. 2004. Solar thermal collectors and applications. *Progress in energy and combustion science*.
- Kalogirou, S. A., Florides, G. and Tassou, S. 2002. Energy analysis of buildings employing thermal mass in Cyprus. *Renewable Energy*.
- Levinson, R., Akbari, H., Konopacki, S. and Bretz, S. 2005. Inclusion of cool roofs in nonresidential Title 24 prescriptive requirements. *Energy Policy*.
- Milne, M., Liggett, R. and Al-Shaali, R. 2007. Climate Consultant 3.0: a tool for visualizing building energy implications of climates. *Proceedings of the Solar Conference Vol. 1. American Solar Energy Society; American Institute of Architects*.
- Mithraratne, N. 2009. Roof-top wind turbines for microgeneration in urban houses in New Zealand. *Energy and Buildings*.
- Niachou, A., Papakonstantinou, K., Santamouris, M., Tsangrassoulis, A. and Mihalakakou, G. 2001. Analysis of the green roof thermal properties and investigation of its energy performance. *Energy and buildings*.
- NYC Environmental Protection. 2012. Guidelines for the Design and Construction of Stormwater Management Systems. Retrieved from http://www.nyc.gov/html/dep/pdf/green_infrastructure/stormwater_guidelines_2012_final.pdf.
- Oberndorfer, E., Lundholm, J., Bass, B., Coffman, R. R., Doshi, H., Dunnett, N. ... and Rowe, B. 2007. Green roofs as urban ecosystems: ecological structures, functions, and services. *BioScience*.
- Parida, B., Iniyar, S. and Goic, R. 2011. A review of solar photovoltaic technologies. *Renewable and sustainable energy reviews*.
- Sailor, D. J. 2008. A green roof model for building energy simulation programs. *Energy and buildings*.
- Santamouris, M., Synnefa, A. and Karlessi, T. 2011. Using advanced cool materials in the urban built environment to mitigate heat islands and improve thermal comfort conditions. *Solar Energy*.
- Sailor, David J. 1995. Simulated urban climate response to modifications in surface albedo and vegetative cover. *Journal of applied meteorology* 34, no. 7: 1694-1704.
- Shaviv, E., Yezioro, A. and Capeluto, I. G. 2001. Thermal mass and night ventilation as passive cooling design strategy. *Renewable Energy*.
- Synnefa, A., Santamouris, M. and Apostolakis, K. 2007. On the development, optical properties and thermal performance of cool colored coatings for the urban environment. *Solar Energy*.
- Van Tijen, M. and Cohen, R. 2008. Features and benefits of cool roofs: The cool roof rating council program. *Journal of Green Building*.

Villarreal, E. L. and Dixon, A. 2005. Analysis of a rainwater collection system for domestic water supply in Ringdansen, Norrköping, Sweden. Building and Environment.

ENDNOTES

1 FM approvals certification assures customers a product or service that has been objectively tested and conforms to the highest national and international standards.

2 Plant-Microbial Fuel Cell generates electricity from organic matter excreted from the roots of living plants.

A design decision support tool for visual comfort evaluation under daylighting conditions

Dalia Hafiz¹

¹Virginia Polytechnic Institute and State University, Blacksburg, VA

ABSTRACT: Light and architectural design are inseparable. Light plays a major role in the perception of the place. Design for spaces often does not fully consider the setting where the building is placed. This connection with the surrounding environment can turn the space into a place where an occupant feels his existence and sense of dwelling. One of the main reasons a good number of today's buildings are unsuccessful in terms of visual conditions and comfort, because they are only focused on function and structure without considering the quality of the place. In response to this there is growing interest in the study of visually disturbing effects such as glare and poor visual comfort.

Several studies on visual comfort have been performed. Very little research examined movement through a space and time-dependency of daylighting. To address daylighting dynamic conditions, this paper attempts to propose a framework for improving design decision-making by evaluating visual comfort. An immersive case study was used for the framework application.

The case study conducted in this paper was a daylit transitional space represented by a museum corridor. The space was evaluated for visual adaptation and glare control. The developed framework used Grasshopper and its sub components to interface with Radiance and Daysim. In addition to quantitative outputs, special re-representation was used for qualitative analysis to support design decision-making. The research outcomes are expected to provide researchers, designers and decision makers with an approach for designing and re-imagining spaces to improve visual comfort and the quality of the place.

KEYWORDS: Visual Comfort, Daylighting, Decision Support, Museums, Design Process.

INTRODUCTION

"We were born of light. The seasons are felt through light. We only know the world as it is evoked by light... Natural light is the only light, because it has mood... it puts us in touch with the eternal. It is the only light that makes architecture", Louis Khan (Bainbridge & Haggard, 2011, p. 136).

Daylighting can play a major role in resource conservation and occupants' level of productivity, health and comfort. Previous research findings showed that views to the outside provided by daylighting have a strong effect on psychological and physical wellbeing (Andersson, Place, Kammerud, & Scofield, 1985).

While daylight is desirable in most living or working spaces its dynamism can create uncomfortable situations causing visual discomfort. The phenomenon of discomfort glare is recognized as one of the most common visual problem that has not been fully quantified and understood (Seamon & Zajonc, 1998).

Visual comfort in offices was investigated by Osterhaus (2009) using a case study approach. The research findings suggested ways to better integrate computer workstations in daylit offices. Other studies focused on the required conditions for visual comfort in educational buildings (CFEE, 1999). The results of these studies showed a positive relationship between increased daylighting and improved test scores and better student performance. Although there have been many studies on visual comfort, several issues exist when implementing daylight. Interior space quality and users' perception was investigated in a study by Kolokotsa et al. It concluded that future investigations using different prediction techniques were needed to improve the predictive control algorithm (Kim, Han, & Kim, 2009). Visual comfort in transitional spaces under overcast sky conditions was examined by Boubekri in (2007).

Very little studies have considered the daylight time and space dynamics. In addition a small number of glare analysis tools are accessible to non-professionals and may require specialized computing and programming skills.

The main objective of this paper is to improve design decision making through the development of a framework that considers visual comfort and glare. To achieve this objective a framework for visual comfort evaluation in daylit spaces was developed to help designers make better informed decisions.

1.0 METHODOLOGY OVERVIEW

This paper is a part of a research that aims at improving design decision-making through a re-representation tool for visual comfort consideration in dynamic daylight spaces. This paper represents two of the research main phases: 1- framework to evaluate visual comfort, especially in transitional spaces, and 2- an immersive case study approach was used test the framework potential in supporting design decision making.

1.1. Phase1: framework

The framework aims at representing glare and visual discomfort conditions that may occur in a daylight space. The framework main stages are: 1- Data input, 2- Analysis and simulations, 3- Evaluation, 4- Visual comfort condition decision, and 5- Designer final decision on redesigning. The stages are discussed in details in the following subsections:

1.1.1. Data input stage

The designer inputs are: a 3D-model for the space, building site geographical location (a weather file), sky condition, simulation times and days, building orientation, and examined circulation path in the transitional space as explained in Table 1

Table 1: Framework data input.

Variable	Description	Software used
Geographical location weather	The weather file was selected based on the geographical location. Weather files can be downloaded from: http://apps1.eere.energy.gov/buildings/energyplus/weatherdata_abo ut.cfm	
Sky condition Date and time (mm dd hr):	Clear sky without sun is the default Annual simulation is the default. Specific days and times can be selected depending on the space function, occupancy hours and daylight hours.	DIVA Grasshopper
Materials properties	A material file is included in the DIVA plug-in with major generic materials; properties include transparency, color, and reflectance. Custom RADIANCE materials can be added to the original file.	
Building orientation	Default north in Rhino software is pointing up	Rhino
Building geometry (3D-model)	Building geometry and surroundings are exported to Rhino where Grasshopper (Rhino plug-in) can run a series of evaluation simulations. Geometry can be saved as 3D-shapes or meshes, and exported to Rhino.	Rhino, accepting exported files from (3D-max, CAD or Sketch-up)
Simulation points/path	A circulation line or curve in the 3D-model where simulation points are placed horizontally at the eye level (5.6ft) and vertically every (7.7ft) based on the average pedestrian speed per second.	Grasshopper and Rhino

1.1.1. Analysis stage

In this stage multiple software are used to evaluate the space visual comfort, the analysis process is shown in Figure 1:

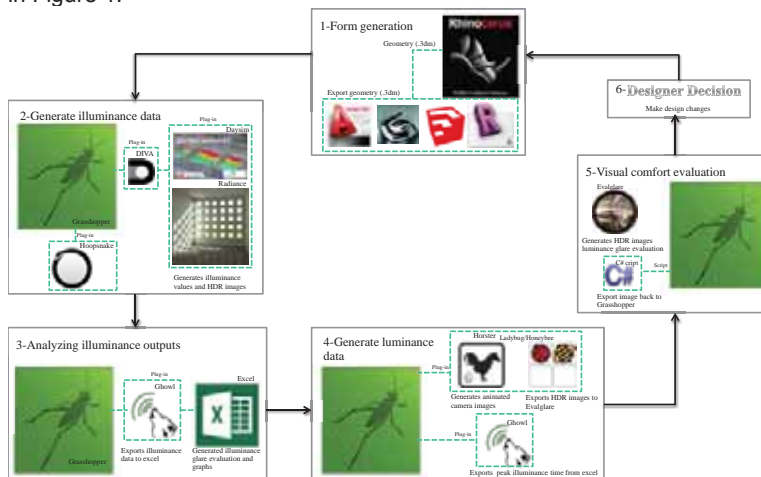

Figure 1: Analysis programs workflow.

- 1- **Form generation:** the design 3D model input is created in any 3D-modeling software, generated geometry is exported in a (.3dm or .3ds) formats to Rhinoceros 3D modeling software.
- 2- **Illuminance data simulation:** illuminance data are generated from the inserted 3D model using Grasshopper (GH); a Rhino graphical algorithm editor (McNeel & Associates, 2007). DIVA-GH (a Radiance interface) is used to generate illuminance data. Hoopsnake is a GH-plugin used to loop through different days and hours.
- 3- **Illuminance analysis:** illuminance data are exported to Excel for analysis using Ghowl, a GH-plugin. Illuminance evaluation (UDI and illuminance ratio) and graphical representation of the data is presented in Excel and peak condition(s) is selected.
- 4- **Luminance simulation:** Ghowl exports the peak condition(s) day(s) and time(s) back to GH. Luminance data are generated through a DIVA-GH visualization simulation to produce an HDR image. An animated camera is placed on the circulation path at the peak point(s) using Horster- GH-plugin. the HDR image Glare evaluation is done through Ladybug/Honeybee; a GH-plugin that interfaces with Evalglare; image glare evaluation software.
- 5- **Visual Comfort Evaluation:** Evalglare evaluates the images luminance (DGP and Max glare points); final visual comfort condition is represented to the designer.
- 6- **Designer Decision:** based on the case evaluation the designer makes the decision on modifications to the initial design and re-run the evaluation.

1.1.2. Design evaluation stage

The research literature review showed that no previous index was intended for visual comfort evaluation in transitional daylight spaces. Consequently the process of identifying glare conditions required the implementation of multiple luminance and illuminance evaluation metrics with associated threshold level. The evaluation output includes the following as dependant variables: 1- illuminance based metrics: (illuminance ratio and Useful Daylight Illuminance) and 2- luminance based metrics: (DGP, maximum glare points) as shown in Table 2.

Table 2: Luminance and illuminance metrics.

	Description	Threshold/guidelines
1-Illuminance based metrics	They are based on the simulation illuminance value at each stationary point on the path.	
Useful daylight illuminance (UDI)	insures that all the simulation points illuminance are within the useful limits (Nabil & Mardaljevic, 2005).	5<UDI<20 FC at least 50% of the time.
Illuminance ratio	The illuminance value for each simulation point was compared with its neighbors and the ratio was evaluated based on the thresholds.	Based on the examined space illuminance ratio of 5:1
2-Luminance based metrics	They are based on the visualization images. A simulated camera "looking straight forward" was placed in the 3D-model at the points and times exceeding illuminance thresholds.	
Daylight Glare Probability (DGP)	DGP is based on the vertical eye illuminance as well as the glare source luminance (Harvard, 2006).	Average perceptible effect (0.38). Points exceeding the threshold should not exceed 10% of the time.
Maximum glare points	Points brightness exceeding (2x) the average brightness of the image. (Larson et al., 1998; REA, 2010)	Points exceeding the threshold should not exceed 10% of the time.

Based on the evaluation findings, a visual comfort condition (intolerable, perceptible or subtle) was presented.

The proposed tool represents a decision support tool: it does not aim to make decisions for the designer. Possible design alterations are endless; consequently the design modification decision is left to the designer as demonstrated in the framework overview in Figure 2.

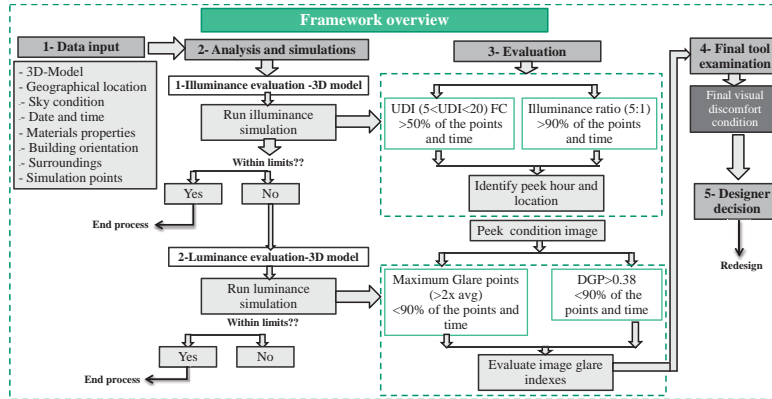

Figure 2: Framework overview

1.2. PHASE2: CASE STUDY

Visual comfort of a passageway “transitional space” between multiple gallery spaces was examined in Freer Gallery of Art, one of the Smithsonian’s museums of Asian art, located in Washington D.C, USA. The museum galleries have a long history of acclaimed exhibitions and present some of the most important holdings of Asian art in the world. The building was selected for many reasons: 1- it carries different artifacts or exhibits sensitivities varying from very sensitive artifacts requiring minimal rather stable light exposure to non sensitive outdoor exhibits 2-daylighting is the main lighting source in the building, and 3- a corridor transitional spaces surrounds the central court and connects the different galleries, Figure 3.



Figure 3: Freer Gallery Museum location and plan circulation

The museum space can be subdivided in terms of illuminance into 6 zones as shown in Figure 4: zone1: The Peacock Room: darkest room (0.8-3FC), zone2 and zone3 oil paintings (2-10 FC), zone4: transitional space (3-30 FC), zone5: old Chinese writings and books (1.2-4.5 FC), and zone6: outdoor court (70-400 FC),

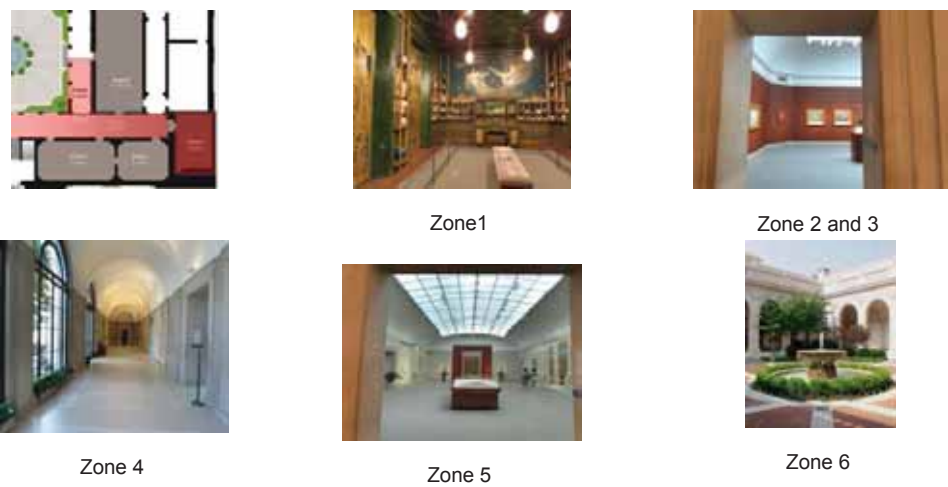

Figure 4: Freer gallery examined lighting zones

1.3. Case study data input

A simplified 3D-model for the museum building was examined for visual comfort, detailed data input are explained in Table 3.

Table 3: Case study data input

Variable	Examined Case properties
Geographical location	The selected museum location weather (Washington DC) was used for this case.
Sky condition	Clear sky without sun
Date and time (mm dd hr):	A one hour interval was simulated for selected days of (December 21- June 21- march 21).
Materials properties	Custom materials are applied based on the in-situ luminance meter measurements.
Building orientation	The 3D model was rotated to match Rhino default orientation
Building geometry (3D-model)	A 3-D model for the examined building was generated and exported to Rhino 3D modeling software.
Surroundings	The building is located on a semi-flat site, no adjacent buildings or significant vegetations.
Simulation points	Points are positioned in the 3D-model circulation corridor- Figure 5.

From the researcher's observation of the visitors' circulation in the museum, one main circulation path was examined: the passageway connecting the Peacock Room (zone1) and the outdoor court (zone6). A circulation polyline was placed in the 3D-model. Simulation points are placed as shown in Figure 5. horizontally at (5.6ft) and vertically at equal (7.7ft) segments. First illuminance simulations were conducted for each point followed by image luminance simulation for the selected peak point(s).



Figure 5 (a): Stationary illuminance points (floor plan).

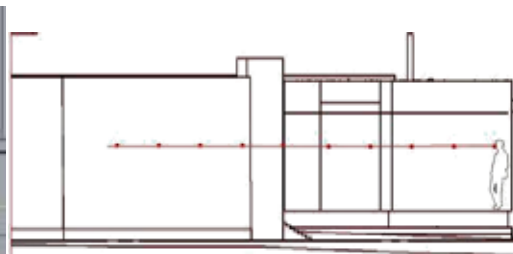

Figure 5 (b): Stationary illuminance points (section).

1.4. Analysis and simulation

Illuminance evaluation: Illuminance evaluation concluded that useful daylight illuminance= 81%, Figure 6(a) and the peak illuminance ratio is found between points in zone4 (corridor-point 5) and the ones in zone6 (outdoor court-point6) = 1:16 as shown in Figure 6(b). Consequently further luminance evaluations were needed at the discomfort point.

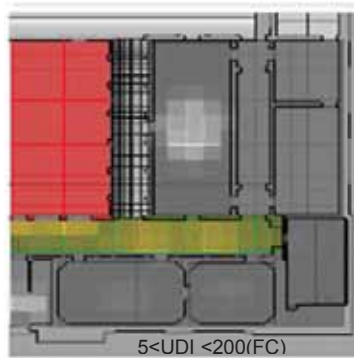

Figure 6 (a): UDI distribution

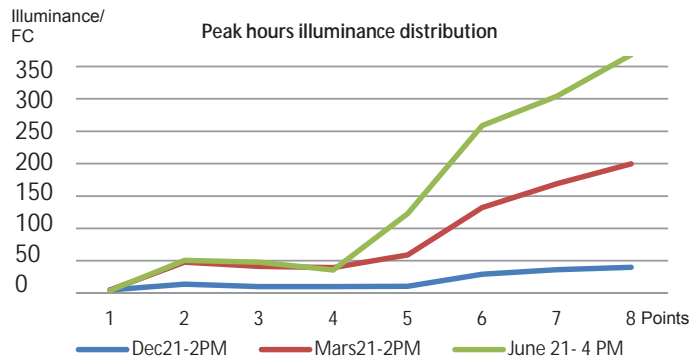

Figure 6 (b): Peak times illuminance distribution

Luminance evaluation: Image luminance analysis is the second stage of visual comfort evaluation.

- 1) A camera with similar human eye lens properties was positioned at the peak stationary point, Figure 7(a)
- 2) An HDR visualization image was simulated using DIVA, Figure 7(b)
- 3) Evalglare was used on the rendered images to obtain DGP and maximum glare points Figure 7(c).

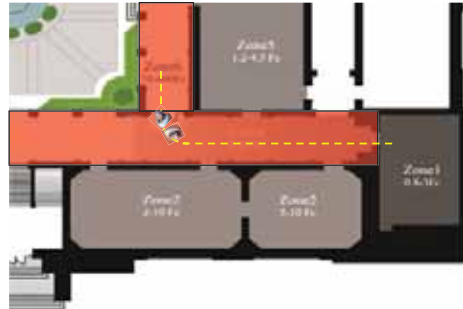

Figure 7(a): Peak point camera

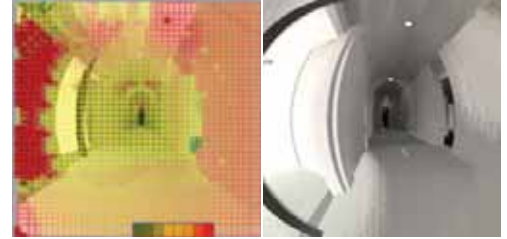

Figure 7 (b): Fisheye image and brightness heatmap



-DGP=0.21
-%glare points in image=12.6%

Figure 7 (c): Evalglare evaluation

1.5. Case evaluation stage and examination

Simulated images were evaluated through the examination of the maximum glare points and DGP indexes. Luminance evaluation concluded that the percentage of image glare points in the visual field was 12.6% (perceptible) and DGP=0.21 (within comfort zone- imperceptible).

1.6. Designer decision stage

Grasshopper software was initially used in the process for its ability to run parametric design; based on the final design evaluation the designer can make better informed decisions on design adjustments. Design modifications are endless and only the designer can decide on design adjustments. The designer can apply parametric analysis on interior or exterior geometry, in addition to materials properties adjustment.

2.0. SUMMARY AND CONCLUSION

Visual comfort study is a significant matter when designing spaces. The goal of this research is to improve design decision making through the representation of daylighting visual discomfort. A design assistance framework was proposed to evaluate a given space from the visual comfort perspective. The case study application examined a transitional daylit space in a museum space where outcomes showed tool adequacy to evaluate visual comfort. The research outcomes are expected to provide designers and decision makers with an approach for designing and re-imagining spaces to improve visual comfort and space quality.

3.0. FUTURE WORK

For the framework evaluation to generate more trusted results some future developments need to be considered including multiple lighting directions, eye directions, visual discomfort in occupants with visual impairments, a database of electrical lighting to be considered in the simulations, the study of the effect of thermal and mood comfort on visual comfort. As a future research step the framework needs to be evaluated by a group of designers to investigate its potentials to inform the design process. In addition a group of daylighting professionals need to examine to tool effectiveness in terms of glare and visual discomfort evaluation. The framework is intended to be developed into a tool that informs the designer with visual discomfort, especially in the early stages of the design process.

REFERENCES

- Andersson, B., Place, W., Kammerud, R., & Scofield, M. P. (1985). The impact of building orientation on residential heating and cooling. *Energy and Buildings*, 8(3), 205-224.
- Araji, Boubekri, & Chalfoum. (2007). An examination of visual comfort in transitional spaces.
- Bainbridge, D., & Haggard, K. (2011, P.136). *Passive Solar Architecture: Heating, Cooling, Ventilation, Daylighting and More using Natural Flows*.
- CFEE. (1999). *Daylighting Schools-An Investigation into the Relationship Between Daylighting and Human Performance*: California Board For Energy Efficiency.
- Harvard. (2006). DIVA user guide. from <http://diva4rhino.com/>
- Kim, W., Han, H., & Kim, J. T. (2009). The position index of a glare source at the borderline between comfort and discomfort (BCD) in the whole visual field. *Building and Environment*, 44(5), 1017-1023.
- Larson, G. W., Shakespeare, R., Ehrlich, C., Mardaljevic, J., Phillips, E., & Apian-Bennewitz, P. (1998). *Rendering with radiance: the art and science of lighting visualization*: Morgan Kaufmann San Francisco, CA.
- McNeel, R., & Associates. (2007). <http://www.grasshopper3d.com/>. *Visual Programming*
- Nabil, A., & Mardaljevic, J. (2005). Useful daylight illuminance: a new paradigm for assessing daylight in buildings. *Lighting Research and Technology*, 37(1), 41-57.
- REA, M. S. (2010). *IESNA Lighting Handbook Reference and Application*.
- Seamon, D., & Zajonc, A. (1998). *Goethe's Way of Science: A Phenomenology of Nature*.

A tale of three zones

Andrea Calhoun¹, Courtney Goertz¹, Garrett Watkins¹, Alison Kwok¹

¹University of Oregon, Eugene, OR

ABSTRACT: With the most recent renovation of Eric W. Allen Hall on the University of Oregon campus, completed in March of 2013, the designers, users, and campus planners are interested in comparisons of predicted and actual thermal comfort levels. This case study serves to analyze thermal comfort in three different zones of the building. Both occupant surveys and physical measurements are utilized to collect data. Further, data will be compared to standards set by American Society of Heating Refrigerating and Air Conditioning Engineers (ASHRAE), in order to check the appropriate performance of the mechanical systems used throughout the building. Allen Hall features three distinct thermal zones, each with their own unique systems and strategies. Based on initial observation, it is hypothesized that the southeast zone, containing the most recent addition, achieves the highest level of thermal comfort. Through quantitative and qualitative analysis, this hypothesis was proven to be partially correct.

KEYWORDS: Thermal comfort, Allen Hall, Post-Occupancy Evaluation (P.O.E.)

INTRODUCTION

Completed in 1922, Eric W. Allen Hall has been an integral part of the campus, housing the School of Journalism and providing a space for student collaboration. In 1954, a new addition was constructed for the expanding program. This building remained relatively untouched until the most recent renovation in 2011 – 2013 (Figure 1), connecting the two buildings and creating a cohesive whole (Woofter, Matthews, 2014).



Figure 1: Rendering of the 2011-2013 renovation of Allen Hall. (© Yost Grube Hall Architecture Inc. and TBG Architects and Planners)



Figure 1: Plan of Allen Hall with thermal zones outlined. (© Yost Grube Hall Architecture Inc. and TBG Architects and Planners)

Figure 3: Allen Hall east atrium.

The three thermal zones (Figure 2) are designated Zone A, B, and C for the purposes of this study. The original building in 1922 utilized operable windows for cooling and radiators (steam) for heating. Today, that portion of that building (Zone B) uses baseboard heating, operable windows, and paddle fans. The 1954 portion (Zone A) is currently heated and cooled by a Variable Air Volume (VAV) system, a type of heating, ventilating, and air-conditioning system that supports one duct, which distributes variable amounts of air in order to achieve designated temperatures. The newest addition (Zone C) uses passive and active chilled beams, baseboard radiant heating, and operable windows. These systems were designed to maintain the integrity of the different areas of the building, to maintain excellent comfort conditions for the students and faculty, and to support campus energy efficiency policies. Strategies for outstanding comfort and efficient building operations were important to becoming a campus model in sustainability and green practices.

When commissioned for the renovation of Allen Hall, the design team had many goals in mind. Among attempts to establish a clear entry and create a collaborative environment, a majority of the other goals were directly connected to the building's upgraded systems and their performance:

1. "Net Zero" in terms of added energy consumption
2. 40% better than Oregon Electrical Specialty Code OESC 2007 Energy Code
3. 25% better than Oregon Electrical Specialty Code OESC 2010 Energy Code
4. 2030 Challenge EUI 60% better than Commercial Buildings Energy Consumption Survey (CBECS)

The design team hoped to "use wisely what [they] had" by considering benefits of the site, water conservation, energy consumption, and life cycle costs. Energy measures such as new windows, insulation and external shading, lighting and controls, temperature drift, central plant cooling, variable chilled water loops, steam to hot water, natural ventilation, passive and active chilled beams, a Dedicated Outdoor Air system, a heat recovery chiller, point of use water heat, and an enhanced Building Automation System were incorporated. However, since the opening of the new renovation in March 2013, no post-occupancy evaluation has been conducted on the performance of these systems.

Through initial observations by our team, we raised the following questions:

1. Are the systems performing to the levels predicted by computer analysis?
2. Why are only the windows on the southeast propped open?
3. How does occupant thermal comfort in each zone compare to each other?
4. In addition, how does occupant thermal comfort compare to that prior to renovations?
5. How do the standards set by ASHRAE Standard 55 compare to occupant's preferences?
6. Are the building systems being operated as intended?

The topic of occupant thermal comfort in Allen Hall is of great interest to the campus planners and architects. The topic became the goal of this study, to compare design intent with actual performance of a building.

1.0 HYPOTHESIS

We hypothesized: “The occupants in the 2011 addition (2nd floor of Zone C) of Allen Hall were the most thermally comfortable in the building according to the comfort zone parameters of ASHRAE Standard 55 Thermal Environmental Conditions for Human Occupancy.”

2.0. METHODOLOGY

The results of this study were gathered through both qualitative and quantitative research methods. Occupant comfort “votes” were compared to the physical conditions measured in each zone. Data was collected on the second floor due to the presence of offices in all three zones. The second floor had numerous faculty and staff offices that were accessible for our study for the distribution of thermal comfort surveys. Only the faculty and staff participated in this study in order to narrow the scope of research and provide results for the occupants whom spend the most time in Allen Hall.

1. Gain necessary permissions: building manager, facility manager, dean's office for access to various spaces for setting up data logging equipment and survey distribution.
2. Develop and test occupant thermal comfort survey using online software (*Qualtrics*). Disseminate survey.
3. Launch 15 Onset HOBO dataloggers (Figure 4), 5 in each zone to collect temperature and relative humidity at 1 minute intervals for one week, including a weekend
4. Place HOBO data loggers in appropriate locations throughout Allen Hall for an accurate and comprehensive analysis. (Figure 5)
5. Compare results of quantitative data to ASHRAE Standard 55 through tables, graphs, and charts.
6. Compare qualitative data with quantitative data and note any trends through graphic analysis and written description.
7. Determine which zone achieves the greatest level of occupant comfort and offer solutions for other lower performing zones.



Figure 4: Onset HOBO datalogger



Figure 5: Datalogger locations on the second floor

3.0. DATA AND ANALYSIS

3.1. Quantitative Data

Quantitative data was collected from May 10, 2014 through May 16, 2014. During this period of time, the average outdoor temperature was 60 °F, with a range between 43 °F and 75 °F. Results from the Hobo data loggers indicated the following office temperatures shown in Figure 6.

Average Daily Temperature:

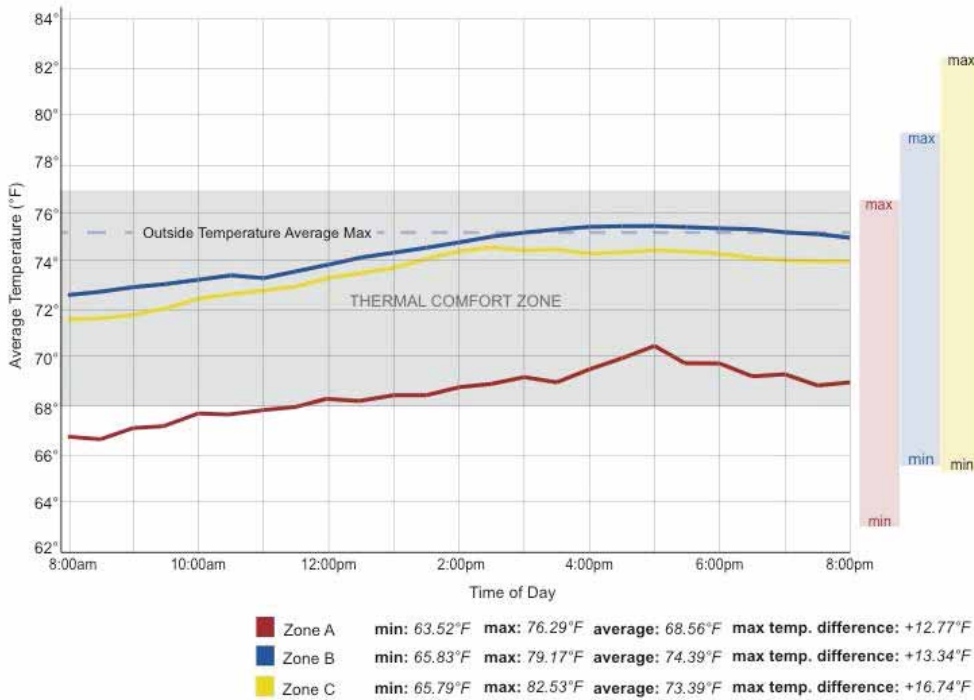

Figure 6: Average daily temperatures in each zone plotted against the temperature parameters of the ASHRAE thermal comfort zone.

According to the data collected and the graph above, all three zones tend to fall within the comfort zone conditions defined by ASHRAE Standard 55. However, Zone B and C tend to be on the warmer side of the comfort zone, while Zone A tends to be cooler. Average temperatures indicate that Zone B and C fall within the comfort zone, while Zone A is slightly too cool. Furthermore, occupant discomfort could be caused by large temperature swings. For example, on Thursday May 15th, temperatures in office 216 A (Zone B) ranged from 65.8 °F to 78.7 °F. This temperature change of more than 12 °F far exceeds the limit of 5.5 °F [Grondzik et.al., 2010].

In addition to temperature, relative humidity was also recorded during the same time frame. The combination of dry-bulb temperature and relative humidity, placed onto the ASHRAE thermal comfort zone allowed visualization of the thermal conditions of each office in each of the thermal zones of the building (Figure 7).

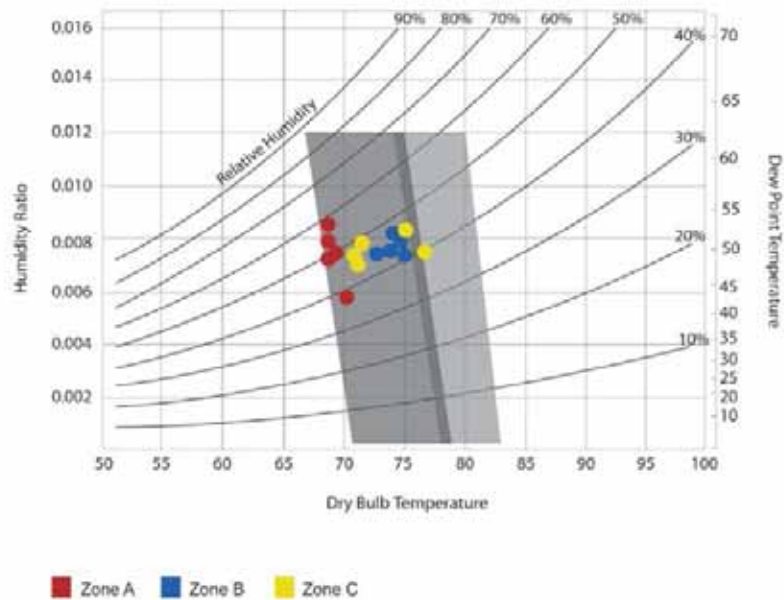

Figure 7: Thermal conditions for each office in each of the Allen Hall thermal zones superimposed on the ASHRAE comfort zone.

Allen Hall's zones tend to cluster within the thermal comfort zone, demonstrating that each heating and cooling system was successfully performing for the time period measured. Zone A tends to operate in a cooler side of the comfort zone, while Zone B and C were right in the middle of the comfort zone. It should be noted that May is a "transitional" season and outdoor conditions were still fairly cool. The darker shaded area of the comfort zone corresponds to "cooler" seasonal conditions when occupants might wear warmer clothing versus the lighter shaded area where conditions are warmer and occupants wear lighter clothing.

3.2. Qualitative Data

An online Qualtrics survey was distributed to the faculty and staff of Allen Hall. A response rate of 26% (36 of 139 surveys) was achieved. We found that occupants in Zone A tend to feel "cool" on the comfort scale; occupants in Zone B tended to feel "slightly warm", and occupants in Zone C felt the most "thermally neutral" or comfortable (Figure 8). These results support the hypothesis, stating that Zone C is the most thermally comfortable zone.

The most common reason stated on the survey for occupant discomfort in both Zones A and B was the inaccessibility of and lack of control over the thermostat. In Zone C, the most common reason for discomfort was the incoming daylight, which would make sense because Zone C is the most southern facing zone (Figure 9). As a result of these reported discomforts, occupants claim to use a variety of thermal adaptations, including opening and closing windows as necessary and wearing extra clothing (Figure 10). Unfortunately, some occupants, especially those in Zone C, do not understand how the systems operate and stated that this confusion inhibits the occupants from making appropriate decisions regarding the control of thermal conditions. Further, confusion is reinforced by unclear and uninformative signage throughout the building, discouraging the use of operable windows at all times. The following quote is taken directly from the Qualtrics survey:

"We don't have individually controlled thermostats, and, as I said before, the building is designed to react to open windows. So, for the most part, I don't open the window because of its potential effect on other offices. That's problematic because we don't know which office controls other offices." – Anonymous

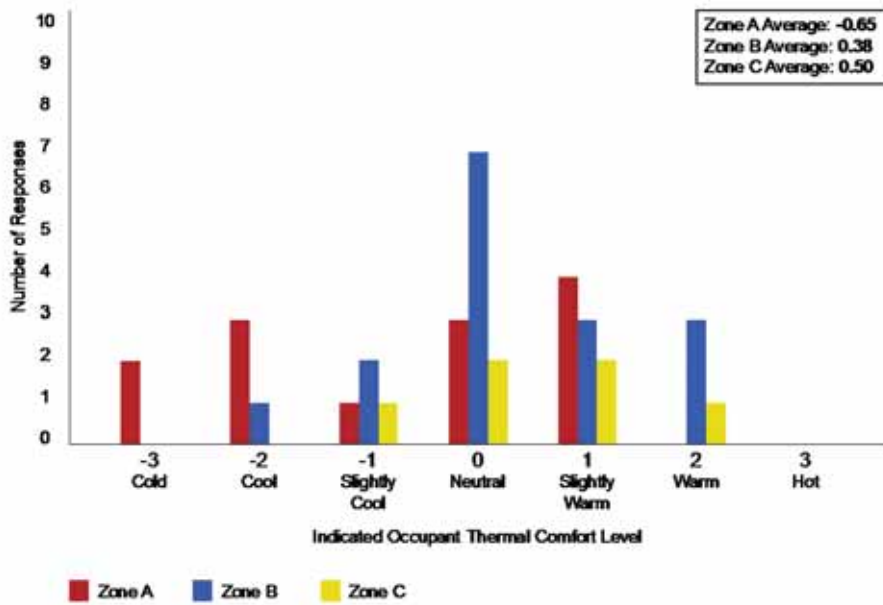

Figure 8: Reported occupant votes of thermal sensation (the range of -1 to +1 is considered to be comfortable).

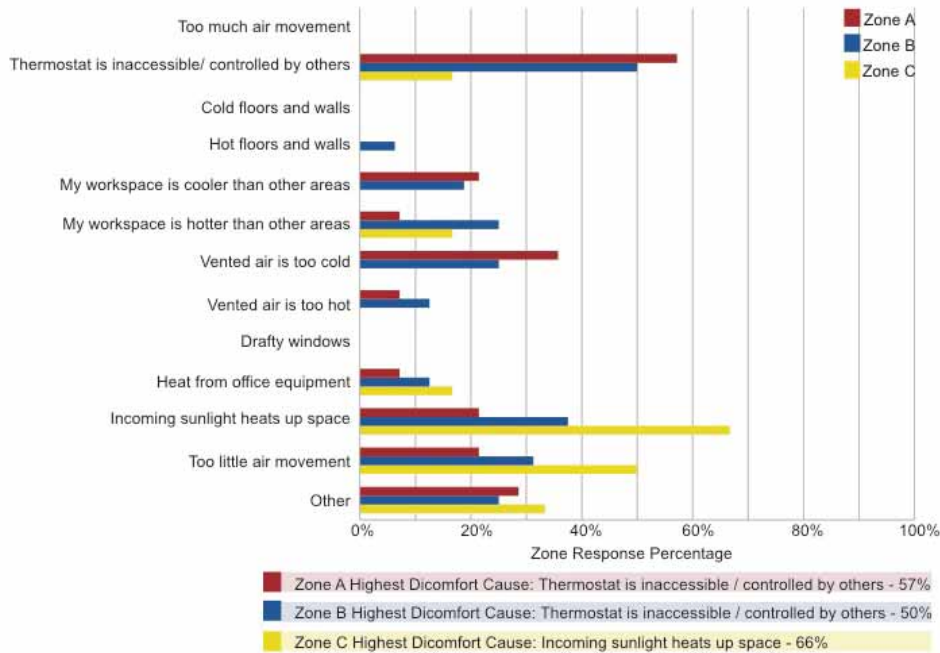

Figure 9: Reported reasons for thermal discomfort.

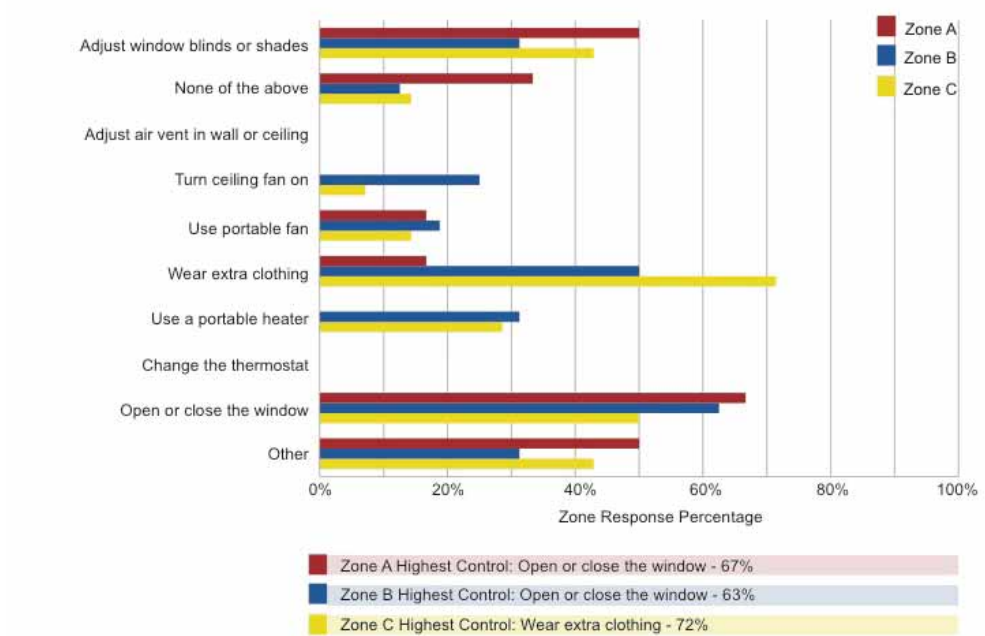

Figure 10: Reported occupant adaptive behaviors to control the thermal environment.

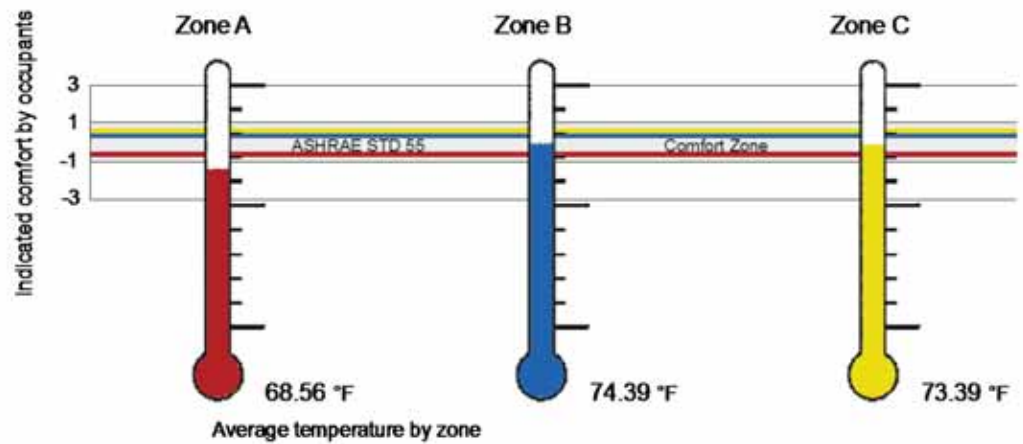

Figure 11: Reported occupant comfort by zone, average temperature, and comfort vote

4.0. DESIGN LESSONS LEARNED

While the heating and cooling systems of Allen Hall provided conditions that met ASHRAE Standard 55 comfort zone criteria, the performance of the systems could be improved by providing better information and education for the occupants about the function and purpose of the systems. In many cases, building occupants were not fully informed of exactly how the heating and cooling systems operate, leading to unnecessary thermal discomfort and wasted energy. For example, occupants who wanted to open their office windows (for fresh air) saw warning signs and were in fear of disrupting the functioning of the mechanical systems and the thermal conditions of neighbouring offices. Those occupants reported using portable fans, which in turn consume additional energy. Thus, more instructive signage and explanations should be provided; training, office manuals, or even an indicator light, installed near the window, indicating appropriate times to open the window might be successful.

CONCLUSIONS

Through both quantitative and qualitative data collection, the hypothesis was proven to be partially correct. We hypothesized that occupants in Zone C would be the most comfortable. The occupant surveys for Zone C showed an average vote of "+0.5" on the thermal comfort scale for both the cool and warm seasons; falling between "-1.0" and "1.0" considered by ASHRAE to be comfortable. Zone A (-0.65) and Zone B (+0.38), both within the comfort range.

The physical conditions of all three zones also fell within the comfort zone criteria specified by ASHRAE 55. Zone C achieved a comfortable thermal comfort rating according to the occupants, while maintaining a temperature and humidity level deemed acceptable by ASHRAE Standard 55. On the other hand, Zone B also achieved thermal comfort according to both qualitative and quantitative data (Figure 11).

ACKNOWLEDGEMENTS

We would like to extend a special thank you to Sue Varani, Richard Ebert, the design team of Allen Hall, and all faculty and staff members who participated in this study. The success of this case study is a direct result of the kindness and support of the University of Oregon School of Journalism and Communication.

REFERENCES

- ANSI/ASHRAE. 2013. Standard 55-2013: Thermal Environmental Conditions for Human Occupancy, American Society of Heating, Refrigerating and Air-Conditioning Engineers, Inc. Atlanta, GA.
- Grondzik, Walter T., A. Kwok, B. Stein, and J. Reynolds. 2010. Mechanical and Electrical Equipment for Buildings. 11th ed. New Jersey: John Wiley & Sons, 2010. Pg. 95. Print.
- "School History: The Building," School of Journalism and Communication. <http://journalism.uoregon.edu/about/history/the-building/> (accessed April 13, 2014).
- Woofter, Miles and Matt Matthews, "Allen Hall Guest Lecture," Lecture, Event from University of Oregon, Eugene, OR, April 11, 2014.

Analyzing energy saving retrofit potential of historic homes in hot-humid climates

Hazem Rashed-Ali¹, William Dupont¹, Randall Manteufel¹, Tomas Thomson¹, Levi Sanciu¹

¹ The University of Texas at San Antonio, San Antonio, TX

ABSTRACT: The implementation of sustainable design practices, building materials and energy efficient products offers benefits to building owners and occupants. An energy efficient and sustainable building can reduce operation and maintenance costs, conserve energy, and improve occupant health. Maintenance and improvements extend the life of building materials, reducing the need for future replacement, thereby saving the need for fabrication and installation of new materials and needless additions to local landfills. Continued use of existing building stock has two primary benefits: 1) retaining the embodied energy of the existing construction, and 2) promoting healthier and stronger communities due to continuity of cultural identity. Property owners need practical, reliable, and accurate information in an accessible format to understand the benefits of employing sustainable products and practices while renovating or retrofitting their existing and affordable homes. Historic homes in particular present unique challenges for energy efficient retrofits both because of the age of the building and its systems and because of the historic preservation-related limitations typically placed on implementing retrofits.

This paper will report on and identify lessons learned from an interdisciplinary project that aimed to identify possible retrofit packages for historic homes in San Antonio, TX. The project, which involved researchers from architecture, mechanical engineering, and real estate finance, aimed to identify cost effective retrofit packages that owners of historic homes can implement to reduce energy use, while maintaining the cultural identity of the homes. The project included the analysis of four case study historic homes constructed in the early twentieth century. Initial results indicate that cost-effective improvements would include installation of a radiant barrier, attic and crawl space insulation, and overall reductions to air infiltration. In general, retention of historic fabric including siding and windows is recommended given the potential negative effect on homes historic character and extended energy savings payback.

KEYWORDS: Historic Homes; Energy Efficiency; Residential Retrofits

INTRODUCTION

Over the past three decades, numerous studies have established the need for adopting the principles and practices of sustainable development. While there is still some lack of consensus over the definition of sustainable development, there is general agreement over the need to balance its three main components: environmental, economic, and social sustainability. The environmental dimension of sustainability stems from the growing realization of the increasing and potentially irreversible damage facing the environment (e.g. WCED 1987, IPCC 2013, IEA, 2014). Offering its strongest assessment to date, the latest IPCC report (IPCC 2013, 2) states that:

"Warming of the climate system is unequivocal, and since the 1950s many of the observed changes are unprecedented over decades to millennia. The atmosphere and ocean have warmed, the amounts of snow and ice have diminished, sea level has risen, and the concentrations of greenhouse gases have increased".

With regard to the question of human influence on climate change, the IPCC goes on to state that:

"Human influence on the climate system is clear. This is evident from the increasing greenhouse gas concentrations in the atmosphere, positive radiative forcing, observed warming, and understanding of the climate system".

Energy related issues have been identified as central issues in the sustainability debate. Reddy et al. (1997) contends that energy is not a sectoral issue but one that is related to numerous dimensions of development, while Johansson & Goldemberg (2004) describe conventional sources of and approaches to providing and using energy as unsustainable and link them to significant environmental, social, and health problems. This increases the significance of studies that aim to identify different strategies to achieve a more sustainable energy system including more efficient use of energy at the point of end use. The built environment plays a major role in the U.S. energy system in particular through energy use in the residential and commercial sectors. The latest data by the Energy Information Agency (EIA 2014) show that in 2013, the building sector accounted for 40.3% of the total energy use in the US with 21.8% of that use happening in the residential sector. This further illustrates the significance of activities aiming at increasing the energy efficiency of buildings in general, and of residential buildings in particular.

Increasing the energy efficiency of the residential sector involves addressing both new and existing housing stocks. Increasing the efficiency of existing residential buildings is particularly important considering that

they are typically much less efficient than new ones. Several studies have focused on identifying appropriate retrofit strategies for existing housing in different climate regions (e.g. Florian et al. 2011, Parker 2001, Burgett et al. 2013). However, not much research has been conducted on the retrofit potential of historic homes despite the historical, cultural and social significance they represent to the communities and cities in which they are located. According to HUD (2008), approximately one third of all residential housing units (about 40 million) were built before 1960. That makes them more than 50 years old and likely to have some historical or cultural value. Unknown quantities of housing units are already listed in protected historic districts, with more being designated each year. San Antonio, for example, has created 28 historic districts beginning with King William in 1968. The fact that products and design details generated for new construction are not always a good fit to older homes, and can actually cause irreparable harm if misapplied further increases the need to investigate this issue using a structured and scientifically-valid approach. Additionally, beyond the scientific concerns of building technology, there are competing values that come into play within designated historic districts. Accurate information from objective experts in a format that can be directly applied to real situations is not available and is needed. The potential savings to be realized from retrofit work on existing, older homes is considerable. At the same time, these historic homes need thoughtful attention to the details and features that cause society to give them protected listings due to their cultural heritage value. Overall, the architectural design and construction field lacks case study analysis of real situations that can benefit older homes. The implementation of sustainable design practices, building materials and energy efficient products offers benefits to the building's owner and occupants. An energy efficient and sustainable building can reduce operation and maintenance costs, conserve energy, and improve indoor air quality and occupant health. Maintenance and improvements extend the life of building materials, reducing the need for future replacement, thereby saving the need for fabrication and installation of new materials and needless additions to local landfills. Continued use of existing building stock has two primary benefits: 1) retaining the embodied energy of the existing construction, and 2) promoting healthier and stronger communities due to continuity of cultural identity.

1.0 PROJECT DESCRIPTION

The project described in this paper was initially envisioned as a response to the lack of research focusing on identifying appropriate retrofit opportunities for historical housing in the US particularly in hot and humid climates. To address this need, the project utilized a case study approach in which four pre-World War II homes located in San Antonio, TX were studied to investigate their energy efficiency retrofit potential. This project represents one of the first attempts to investigate this issue in the southwest region of the country. The project aimed to identify practical and economical retrofit measures and design solutions that are based on measurable data, and that can assist contractors and homeowners of historic homes in improving the energy efficiency of their homes in a manner that does not affect the historical and cultural value those homes represent. Findings from this study will allow those homeowners and contractors to make better-informed decisions when considering maintenance, changes or improvements on a historic house. Similar to many other sustainability-related projects, this one addressed a complex set of issues on the environmental, social, cultural, and economic fronts. This made it difficult if not impossible to investigate the problem through a single disciplinary lens. To respond to this complexity, the project adopted an interdisciplinary approach in which a team of researchers from different disciplines and with complementary sets of expertise were involved. The team was led by an expert in historic preservation, and included researchers with primary expertise in the areas of building performance simulation and evaluation, building systems, and real estate finance. This approach made it possible to fully address the complexity of the issues involved and to reach conclusions that are based on sound research while at the same time having practical value to the project's target population. The activities described in this paper represent the first phase of a longer-term effort to investigate the issue of energy efficiency retrofits of historic home, in which specific energy efficiency-related retrofit measures will be installed in historic homes, and their impact on the buildings' energy use will be monitored and verified. The second phase of the work is currently underway in which a similar case study approach is being utilized to investigate the impact of installing radiant barriers in the attics of historic homes from the same time period.

2.0 METHODOLOGY

As mentioned above, the work described in this paper represents the first phase of a larger and longer-term project. The aim of this phase was to identify and prioritize retrofit measures that can both increase the energy efficiency of historic homes as well as preserve their cultural and historical characteristics. Following a case study approach, this first phase involved a detailed study of four historic homes from the pre-World War II period. All four homes were located in the Lavaca neighbourhood of downtown San Antonio. Lavaca was designated as a historic district by the City of San Antonio in 2001. The methodology used in this study consisted of five phases, which will be described in more detail in the following sections.

2.1. Review of relevant literature

The review of literature focused on both identifying prior studies with similar or related focus, as well as researching energy efficiency retrofits in general from the point of view of their suitability for historic homes. With regard to previous studies, the review indicated a general shortage of studies focusing on existing homes and in particular historic ones, especially those that aim to establish a sound research base for their findings. A small number of studies were identified that investigated the retrofit potential of historic homes in cold climates (e.g. Cavalo 2005, Culver and Randall 2010, and Verbeeck and Hens 2005). While useful in terms of methodology, conclusions reached in these studies have limited applicability to homes in hot and humid climates given the large differences between the demands and potentials offered by both climate regions. In hot and humid climates, the Florida Solar Energy Center (Parker et al. 2001) conducted a study, which used a case study approach to investigate the retrofit potential of installing radiant barriers in existing homes in central Florida. Pacific Northwest National Laboratory, PNNL (Chandra et al. 2012) conducted a similar study that covered 51 homes in marine, cold and hot-humid climates including six homes in Atlanta and three in San Antonio. Burgett et al. (2013) used a simulation-based approach to identify retrofit packages for existing homes in hot and humid climates in general. Several other studies focused on monitoring existing homes in hot and humid climates to better understand their load profiles including Parker (2003) which monitored 204 homes in central Florida, and Florian et al. (2011) which included a similar study by CPS Energy, the local municipal utility in San Antonio, monitoring 8 homes in San Antonio. None of these studies, however, addressed the unique conditions presented by historic homes, thus establishing the need for the project described in this paper. These previous studies also helped in identifying retrofit measures generally recommended for existing residential buildings. A more detailed review was then conducted for these measures to identify their potential suitability for historic homes and potential impact on the homes' historical character. This review also covered the costs of installing each of these retrofits in historic homes in San Antonio, which was later used in identifying the potential economic payback each of those retrofit measures can achieve.

2.2. Conditions assessment of case study homes

Four historic homes located in the Lavaca Historic District in San Antonio were selected for the study through a recruitment process in which owners of historic homes with the desired characteristics were encouraged to participate. A detailed conditions assessment was then conducted for each of these four homes. The assessment included the following activities:

- 1) A visual inspection of the homes, which aimed to insure that they represented the typical characteristics of historic homes from the targeted period in San Antonio primarily in terms of size, construction, and lack of major prior retrofits. The details of those house characteristics are included in Table 1. The inspection also aimed to identify major energy efficiency problems or deficiencies in those home including potential issues in the building envelopes (see Fig. 1a, b) and/or in major energy-consuming systems such as HVAC, domestic hot water, or major appliances. Additionally, the inspection utilized infra-red photography to identify area with major infiltration issues in the building envelop (see example in Fig. 1,c)

Table 1: Characteristics of case study homes.

	Home 1	Home 2	Home 3	Home 4
<i>Construction date</i>	1904	Circa 1883	1919	1910
<i>Size (CFA)</i>	1,465 ft ²	1,567 ft ²	1713 ft ²	2099 ft ²
<i>Number of stories</i>	1	1	1.5	1
<i>Number of users</i>	1	4	2	4
<i>Construction</i>	Wood frame on wood piers, raised floor, sheet metal roof.	Wood frame on concrete piers, raised floor, sheet metal roof.	Wood frame on wood piers, raised floor, sheet metal roof.	Wood frame on concrete piers, raised floor, asphalt shingles.
<i>Insulation status</i>	No floor, some parts of walls and roof.	Wall and roof insulation added.	No walls or floor, insulated roof.	No wall or floor, some roof.
<i>Glazing</i>	Single glazing, wood frame, poor condition.	Single glazing, wood frame, poor condition.	Single glazing, wood frame, poor condition.	Single glazing, restored and new.
<i>Cooling system</i>	Central air, 12SEER	Central air, 14SEER	Central air, 10SEER	Central air, 16SEER
<i>Heating system</i>	Electric resistance	Gas furnace, 80 AFUE	Gas furnace, 80 AFUE	Electric resistance
<i>Electric lighting</i>	Incandescent	All CFL	75% CFL	Incandescent
<i>Prior retrofits</i>	Modern kitchen	HVAC; some insulation around openings; roof;	Insulation and radiant barrier in attic.	Window replacement and restoration.



a) poor attic condition in home 3, b) uninsulated attic in home 2, c) infiltration losses in home 2
Figure 1: Sample images from the visual and infra-red inspection of the case study homes.

2) A detailed conditions assessment conducted by a certified home energy rater including a blower door test, a duct leakage test, and identification of the HERS rating for the home. Results of this assessment for each home are included in Table 2, and sample images for the testing are included in Fig. 2. Assessment results shown in Table 2 illustrate the generally poor level of energy efficiency in all four homes, which was expected given their age and condition. However, they also illustrate that the homes showed considerable differences in their performance as indicated by their HERS rating, which ranged from 131 in home 4 to 296 in home 1, representing a difference of more than 225% in energy performance. This is a typical situation with existing homes and in particular historic ones.

Table 2: Results of case study homes conditions assessment.

	Home 1	Home 2	Home 3	Home 4
<i>HERS Index</i>	296	143	204	131
<i>Blower door results</i>	8,876 CFM50	10,495 CFM50	7,508 CFM50	7,845 CFM50
<i>Duct leakage to outside</i>	Front system: 185 CFM25 (15.4%) Back system: 210 CFM25 (17.5%)	193 CFM25 (9.7%)	600 CFM25 (app. 50%)	System 1: 193 CFM25 (12%) System 2: 159 CFM25 (10%)



Figure 2: Door blower testing performed for case study homes.

3) A detailed homeowner survey was also conducted for each of the homes, which collected information on the major energy using systems in the homes, their efficiency, and year of installation. The survey also collected information on energy use patterns and user behaviour, which varied considerably between the four homes. This information was later used to develop and calibrate the energy models used in this study. The survey was adapted from a homeowner survey developed by PNNL for their study discussed above (Chandra et al. 2012). Two years of electricity and gas usage, were also collected for each home.

2.3. Real-time monitoring of energy use

Energy monitoring systems, eMonitors, were installed in each of the four case study homes. The systems provided real-time monitoring of the homes' electricity usage at one-minute intervals. The installed systems monitored both the homes' overall electricity use as well as some end uses depending on the configuration of each home's main electric panel. Data from the monitoring was available to the research team through a web interface, which provided some aggregated metrics as well as the ability to download the raw monitoring data. In most cases, the sub metering allowed for the identification and separation of the energy use of the HVAC system and some major appliances. However, in several homes, the main electric panel did not provide sufficient flexibility to allow for the more fine-grained monitoring of different electricity end uses that the eMonitor system is capable of. This was mainly due to the lack of sufficient sub-circuits or the inadequate distribution of the sub circuits over the different end uses. The eMonitor systems remained installed in the case study homes for at least one year. However, in some cases minor losses of data of a few hours to a couple of days were experienced due to power outages or, in one case, to the accidental disconnection of the system by the owner. In another case, several weeks of data were lost due to hardware failure of the eMonitor system. With all that in mind, the eMonitor systems still provided the

research team with valuable information about the energy use patterns within the homes. This information helped in the calibration of the models as will be discussed in the following section. The information also provides the potential for additional studies investigating the differences in usage patterns between the homes and their impact on energy use.

2.4. Performance simulating and model calibration

A whole-building energy use simulation model was developed for each of the four case study homes using the software IES-VE 2012 (IES 2013). The model development was based on the conditions assessments discussed in section 2.2 including the visual survey, measurements of house dimensions, homeowner surveys, and the energy audits conducted by the home energy rater. Information from the homeowner surveys were particularly important in developing appropriate occupancy and systems schedules for the different homes, which was an area in which the survey showed considerable differences between the home owners/users. Other simulation parameters not included in the sources above were based on the Building America program research benchmark definition (Hendron 2008). The model was calibrated primarily using information from the utility bills collected from the homeowners, which provided two years of electricity and gas usage information for each home. Utility bill information as adjusted to correspond to calendar months to overcome the inconsistency of the billing periods' lengths and dates. Additional calibration was also conducted based on information gained from the real-time monitoring system especially with regard to occupancy profiles and usage patterns of different systems in the homes. The results of the calibration are included in Table 3 below. As shown in the table, utility data for all homes showed an increase in usage in 2012 compared to 2011, which could be explained in the most part by differences in climatic conditions. The results of the calibration shown in the table indicate that the energy use of the calibrated model was between +9.3% to -8.2% with the exception of Home 2. For home 2, the utility usage was considerably high in 2012, which is likely due to changes in user behaviour.

Table 3: Results of performance model calibration.

	Model EUI (<i>kBtu/sqft/yr</i>)	2011 Utility data EUI (<i>kBtu/ft²/yr</i>)	Model vs. actual	2012 Utility data EUI (<i>kBtu/ft²/yr</i>)	Model vs. actual
<i>Home 1</i>	43.5	41.0	+6.1%	47.4	-8.2%
<i>Home 2</i>	50.9	46.7	+9.1%	66.7	-23.6%
<i>Home 3</i>	69.5	63.6	+9.3%	73.5	-5.3%
<i>Home 4</i>	30.9	29.4	+4.8%	32.6	-5.3%

2.5. Simulation of retrofit measures

Following the model calibration process, a parametric analysis was conducted in which a series of possible retrofits, previously identified from the literature, were simulated using IES-VE, and the impact of each of the proposed retrofits on the annual energy use of the homes was determined. The main types of retrofits investigated through simulation included: 1) reducing infiltration energy losses through weather stripping of historic windows and doors, sealing of HVAC ducts, and sealing of gaps and cracks in the building envelop; 2) adding envelop insulation / increasing the R-value for the walls, attic, and/or crawl space; and 3) replacing single glazed windows with double-glazed ones. Other model characteristics including user behaviour patterns were maintained the same as in the base models. Retrofits were only simulated in the homes in which they could be applied. For example, adding attic insulation was only simulated in the two homes that did not contain such insulation to begin with. For certain retrofits, such as reducing infiltration losses, several levels of reduction in infiltration were investigated responding to different possible retrofit measures.

Other retrofits were also investigated including lighting system retrofits, adding radiant barriers to attics, and adding whole house fans. For the retrofits investigated through simulation, an estimate of the annual savings achieved from implementing these retrofits was calculated based on achieved reductions in energy use (electric and gas) and local cost of energy. An average savings was then calculated for the four homes and used to calculate a simple payback for implementing the retrofit measure based on the local cost of installation. Evaluations of retrofit measures that were not simulated were based on estimates of savings included in prior studies. The results of the analysis were used to identify the optimum retrofit measures for historic homes as will be discussed in the following section.

3.0 IDENTIFICATION OF OPTIMUM RETROFIT MEASURES

The final stage of the work involved the identification of appropriate retrofit measures for the target population of the study, historic homes in San Antonio. Retrofit measures selected were those that offered the most potential from the points of view of energy savings and economic payback, as indicated by the simulation results and previous studies, while at the same time not having a negative impact on the historic character of the homes or the culture significances they represent within their communities. The recommended retrofit measures were divided into three categories: 1) primary retrofits, including retrofits

that have a high impact on the home's energy use, a relatively short payback time, and minimal impact on the historic nature of the homes, 2) secondary retrofits, including retrofits that have a high impact on the home's energy use but were not easily implemented given the typical construction of the historic homes and the desire to preserve their character, and 3) retrofits that had a high impact on the home's energy usage but offered relatively long payback periods. Certain retrofit measures were not recommended mostly due to their potential negative impact on the historic character of the homes. The recommendations resulting from the work were included in a project report (Dupont et al. 2013) as well as in a series of posters (see Fig. 3) aimed in particular at homeowners of historic homes in the area. The following sections provide a brief summary of the recommended measures:



Figure 3: Posters illustrating recommended retrofit measures.

3.1. Primary retrofit measures

Primary retrofit measures identified within this study include: 1) attic insulation, which resulted in an average energy savings of 18.7% and a simple payback of 9-12 years, assuming an initial cost of approximately \$2,500; 2) sealing HVAC ducts, which had an initial cost of \$1,000 and resulted in a simple payback of 3-10 years; 3) radiant barriers, which were not simulated but were still recommended based on results of previous studies; and 4) attic ventilation, which was again recommended based on generally accepted guidance for residential home performance.

3.2. Secondary retrofit measures

The first retrofit measure identified within this category was reducing air infiltration through weather stripping the homes' historic windows and doors. Energy savings from reducing infiltration ranged between 15% to 40% reduction in overall energy use depending on the condition of the home and the level of infiltration reduction achieved. Weather stripping doors and windows resulted in a simple payback of 3-8 years. Adding thermal insulation to the crawlspace was also recommended as a secondary measure and resulted in an average reduction of approximately 15% in overall energy use, with a simple payback of 6-8 years. Several options were examined for crawl space insulation from the point of view of ease of installation and future maintenance potential, and rigid board insulation was recommended as the best option for historic homes.

3.3. Less effective and non-recommended retrofits

The study also identified a group of retrofit measures which can result in relatively high levels of energy savings but would result in very long payback periods, are difficult to implement given the historic nature of the homes, or both. Examples of those include replacing the historic windows with more efficient double-glazed ones, which resulted in a payback of 15-20 years; further reductions in infiltration through sealing of gaps and cracks in the raised flooring, walls, or ceilings, which are generally more difficult to achieve in historic homes; and the installation of whole house fans to be used in the spring and fall seasons instead of the HVAC system. Several measures were also not recommended because of their potential negative effect on the homes historic character and/or being difficult to implement. Examples of those include adding wall insulation or a vapour retarder, and installing storm windows.

3.4. Real estate prices analysis

While a simple payback analysis shows the order one should pursue energy efficient upgrades, the payback period may exceed the horizon over which the homeowner plans to remain in that house. A follow on question is whether a subsequent purchaser will pay a premium for energy efficient upgrades. As part of

this study, an economic study was conducted to assess the degree that green retrofits affect the sales transactions prices. We analysed all of the sales of houses 50 years and older (6592 transactions) that sold through the Multiple Listing Service (MLS) in San Antonio, between October 2009 and December 2012. In addition to the standard variables of house size, style, garage spaces, number of bedrooms and bathrooms, etc. this MLS contains data fields to indicate whether the house has Green Certifications (such as LEED or Energy Star, which are becoming more common in new houses), Green Features (such as drought tolerant plants or low flow plumbing fixtures), and Energy efficiency Features (such as radiant barriers, additional insulation, and high efficiency HVAC systems). Table 4 shows the breakdown of our sales by age grouping, including how many transactions were available for each age group, and how common it was to observe a Green Certification (quite uncommon), Green Feature, or Energy Efficient Feature. Energy Efficiency Upgrades are the most commonly observed form of a green upgrade. We also combined these features into a single measure that at least one of these indicators was present (SomeGreen). In our sales transaction data we see that about 16% of sales show a green upgrade. Using Ordinary Least Squares we regressed the log of sales price on the variables that are known to affect sales prices (such as size, bathrooms, garage space, style, neighbourhood amenities, etc.) and our green indicators. Table 5 presents the key finding. Of interest to this study, is the coefficient for SomeGreen, which is statistically reliable 0.094. Because we use the log of house price, this result shows that for in our sales transactions data base, houses more than 50 years old that have at least one green upgrade, sell for a statistically significant 9.4% more than otherwise identical houses that have no green upgrades.

Table 4: Housing sample description for economic analysis.

Age Group	Age N	Average Age	# With Green Certification	# with Green Features	# with EE Features	SomeGreen
1	3272	55.6	3	84	498	522
2	1563	64.4	3	42	245	256
3	666	75.0	2	23	99	105
4	730	85.0	2	23	118	120
5	361	99.4	3	21	58	64

Table 5: Regression analysis results and parameter estimates.

Variable	DF	Parameter Estimates	Standard Error	t Value	Pr > t
<i>SomeGreen</i>	1	0.09354	0.02968	3.15	0.0016
<i>age</i>	1	0.00078215	0.00051221	1.53	0.1268
<i>SqFt</i>	1	0.52847	0.01332	39.66	< 0.0001

SUMMARY AND CONCLUSIONS

Findings from this project are helpful in three ways: 1) they aid historic homeowners in making smart investments in energy improvements; 2) they identify and recommend improvements that retain the integrity and identity of the architecture of the homes; and 3) they pioneer methods of reducing energy consumption in historic homes in hot and humid climates, all of which should be of great interest and value to the various stakeholders. In general, the results of the project indicate that retention of historic fabric is found to be compatible with attainment of energy savings, increased comfort, and increased home values. The general methodology used in this project, which utilized a case study approach combined with building performance simulation, is consistent with similar studies to assess the impact of retrofits of existing buildings and identify optimum retrofits. The small sample size and the large differences in performance between the selected homes made it difficult to reach more specific results with regard to the economic payback of installing different retrofit measures. This was addressed through providing a range of economic performance for each retrofit. However, such variations in performance are typical for residential buildings in general and historic ones in particular, and therefore the results can be considered as representative of this challenging sector of the market especially for homes located in areas similar to San Antonio. The depth of information collected within this study, including the detailed homeowner surveys and the real-time monitoring, add to the validity of the results and somewhat mitigate any limitations that may result from the small sample size. The real time energy monitoring component of the methodology allowed for a finer-grain calibration of the model, although this was sometimes affected by the technical difficulties encountered in collecting data from the monitoring systems as discussed above. Having such a component, however, will be key in the following phases of the work as discussed below. The inclusion of economic payback analysis also added considerably to the value of the study to its primary target population of contractors and historic homeowners in San Antonio, although the results may vary for other parts of the country in which installation costs can be different.

ACKNOWLEDGEMENTS

This research was made possible by a grant from the Office of the Vice President for Research at the University of Texas at San Antonio and by generous support from the City of San Antonio Office of Sustainability and from Eco-Synergy Advisors who conducted the energy audits of the case study homes. The authors would also like to thank Claudia Guerra for her valuable contributions to the work. Finally, the authors would like to thank the homeowners of the case study homes for volunteering to this study.

REFERENCES

- Burgett, J. M., Chni, A. R., and Oppenheim, P. 2013. *Specifying residential retrofit packages for 30 % reductions in energy consumption in hot-humid climate zones*. Energy Efficiency, 6, pp. 523-543.
- Cavalo, J. 2005. *Capturing energy-efficiency opportunities in historic houses*. APT Bulletin, 36(4), pp. 19-23. Association for Preservation Technology International (APT).
- Chandra, S., et al. 2012. *Pilot residential deep energy retrofits and the PNNL lab home*. PNNL-21116, Pacific Northwest National Laboratories.
- Culver, J. H. and Randall, B. 2010. *Saving Energy in Historic Buildings: Balancing Efficiency and Value*. APT Bulliten, 41(1), pp. 5-12. Association for Preservation Technology International (APT).
- Dupont, W., Rashed-Ali, H., Manteufel, R., Thomson, T., Guerra, C. and Sanciu, L. 2013. *Energy retrofits for historic homes in hot humid climates*. Center for Cultural Sustainability, University of Texas at San Antonio.
- EIA, Energy Information Administration. 2014. *Annual energy review*. Available electronically at: <http://www.eia.gov/totalenergy/data/annual/>
- Florian, T., Rashed-Ali, H., and Von Schramm, V. 2011. *Post-occupancy evaluations of high-performance homes*. Presented in GreenBuild2011 International Conference and Expo. October 4-7, Toronto, Canada.
- Hendron, R. 2008. *Building America research benchmark definition*. Technical Report NREL/TP-550-44816, National Renewable Energy Laboratory, Golden, CO.
- HUD (US Department of Housing and Urban Development). 2008. *American Housing Survey for the United States, 2007*. U.S. Department of Housing and Urban Development and U.S. Department of Commerce.
- IEA, International Energy Agency. 2013. *World Energy Outlook*. International Energy Agency, Paris, France.
- IES, Integrated Environmental Solutions. 2014. IES-VE Pro Software. Available from: <http://www.iesve.com/>
- IPCC, Intergovernmental Panel on Climate Change. 2013. *Fifth assessment report - climate change 2013, Summary for policy makers*. IPCC. Retrieved from: <http://www.ipcc.ch/report/ar5/wg1/>
- Johansson, T.B.; and Goldemberg, J. (eds.) 2004. *World Energy Assessment: Overview 2004 Update*. United Nations Development Program, New York, NY.
- Parker, D. S. 2003. *Research highlights from a large scale residential monitoring study in a hot climate*. Energy and Buildings, 35 (9), pp. 863-876, Elsevier.
- Parker, D., Sherwin, J., and Anello, M.. 2001. *FPC residential monitoring project: new technology development – radiant barrier pilot project*. Report FSEC-CR-1231-01, Florida Solar Energy Center, Cocoa, Florida.
- Reddy, A.K.N.; William, R.H., and Johansson, T.B. 1997. *Energy after Rio, Prospects and Challenges, Executive Summary*. United Nations Development Program, New York, NY.
- Verbeeck, G. and Hens, H. 2005. Energy savings in retrofitted dwellings: economically viable? Energy and Buildings, 37(7), pp. 747-754. Elsevier.
- WCED (World Commission on Environment & Development) 1987. *Our Common Future*. Oxford University Press, Oxford, UK.

Bridging the gap: Supporting data transparency from BIM to BEM

Mohammad Hijazi¹, Karen Kensek¹, Kyle Konis¹

¹University of Southern California, Los Angeles, CA

ABSTRACT: The exchange of information between a digital building model and analytical software should be seamless so that designers can easily use their 3D models for simulation. However, many gaps exist between Building Information Modeling (BIM) authoring software and Building Energy Modeling (BEM) tools. One gap is the loss of data in the exchange between the design and energy simulation models. The data exchange is often done using Green Building XML (gbXML). This file format has the ability to hold both geometric and non-geometric data such as wall constructions and occupancy schedules. An initial step was to check that the data was actually being transferred correctly and completely between the BIM and energy analysis software before simulation. To test this, a simple model was exported from the BIM authoring software using gbXML and then imported to selected energy simulation tools. In some cases, the exchange of data was not complete or was inaccurate, and it was not transparent to the user what was being exported or imported. Generally, the biggest problem was the inability of the simulation software to import the necessary parameters. This is a major flaw in perceived software interoperability and a failure to uphold user expectations. Users might assume that the data transfer is accurate and base design decisions on faulty values, or users might decide that because not all parameters are being transferred, a BIM to BEM data exchange process is useless. One could show the user not only what is being exported, but also what is actually input as the file is loaded into the energy software. A methodology was created for the development of a *Data Transparency Tool* (DTT) that would allow the user to verify the data in the data models and then correct omissions. A demonstration version was produced to confirm the methodology.

KEYWORDS: Building Information Modeling, (BIM), Building Energy Modeling, (BEM), Interoperability, Gbxml

INTRODUCTION

Energy efficiency is more than ever a critical concern that should be addressed in the earliest stages of design. Explaining, understanding, and enhancing the data transfer between software would allow better design decisions through more accurate coordination between energy simulation and building modeling. This research examines building information modeling's (BIM's) role in project data transfer from design to energy simulation. BIM has proved to be a valuable asset overall in offices but seems to have interoperability issues. A methodology was proposed to identify some of these issues and then propose an enhancement through a *Data Transparency Tool* (DTT).

1.0 BACKGROUND

1.1. Building Information Modeling (BIM)

BIM is a widely encompassing term. For many, it is the logical successor to CAD, a 3D parametric modeling program with associative data and the ability to interoperate with other software. The United States General Services Administration (GSA) expanded the definition:

The resulting Building Information Model is a data-rich, object-based, intelligent and parametric digital representation of the facility, from which views appropriate to various users' needs can be extracted and analyzed to generate feedback and improvement of the facility design (GSA 2007).

This definition focuses on the overwhelming potential of creating and using a coordinated database or multiple databases throughout the lifecycle of a building. The BIM is thus useful to many stakeholders at different times: the owner, government bodies, architects, engineers, consultants, construction managers, contractors, sub-contractors, facility managers, occupants, the general public, and others.

1.2. BIM as a useful base model for simulation

Increasingly, the computer has been used to predict building performance, and BIM is one pathway for providing both geometric information and other characteristics of the virtual building. Although BIM has become widely used in architecture firms for the 3D modeling of buildings and production of construction documents, the transfer of the 3D information to other software programs is not always seamless or

complete. This creates a gap between the design development and the energy analysis of different design decisions. As a consequence, energy conscious strategies that are determined early in the design process by the architect may not be used to their fullest potential. BIM is especially useful because architecture firms often have a digital building available that they can use. It can also later be shared with consultants as a base model for more detailed energy calculations.

1.3. BIM gap and interoperability

Project losses caused by interoperability are apparent. The US National Institute of Standards and Technology (NIST) issued a report in August 2004 that estimated that \$15.8 billion was lost annually by the U.S. capital facilities industry due to inadequate software interoperability. The research included "design, engineering, facilities management and business processes software systems, and redundant paper records management across all facility life-cycle phases." The value was reached by comparing the actual costs with a hypothetical scenario in which the data exchange, management, and access were seamless (Gallaher et al. 2004).

There is an interoperability gap between 3D authoring software and energy simulation tools. The exchange of information between analytical software and the building model should be more seamless and allow for a complete feedback loop. Accuracy and completeness of data are important in its transfer between the BIM and energy simulation software for both the 3D geometry and the data (non-geometric).

1.4. Green Building XML schema (gbXML)

gbXML is an open schema developed specifically to transfer building geometry and thermal data and to enable interoperability between BIM authoring software and energy simulation tools. It was initially funded by the California Energy Commission PIER Program, Pacific Gas and Electric, and Green Building Studio. gbXML is now supported by the majority of the software vendors including Autodesk, Bentley, and Vectorworks (gbXML 2014). It has been checked for its degree of accuracy and completeness for a range of energy simulation programs. A gbXML file is a text-based file. It is divided into elements that define the document, the geometry, and the materials of the project in a hierarchical structure (Fig. 1).



Figure 1: The textual representation of a floor assembly from Revit (left), the representation in gbXML (center), the structure of the gbXML file (right).

1.5. BIM to BEM data flow

"Energy is a design topic, not a technology topic, but there are few of us who have always believed this" (AIA 2012). Therefore to become effective, energy efficiency should be a key factor in the design of buildings and consequently should be carefully analyzed throughout the design process. The BIM/BEM workflow should be seamless to support this analysis; unfortunately and as reported by the following results, it is not. Problems have been faced with both the use of gbXML and IFC (Industry Foundation Classes) as a method of interoperability.

Some researchers claim the lack of seamless connectivity between BIM and BEM tools is deeply rooted in their development. Claiming that BIM development focused on supporting critical building construction contexts, while BEM development concentrated on buildings elemental characteristics and their interactions (Srinivasan et al. 2012). While other researchers speculate that the main issues derive from BEM tools' incapability to interpret object-oriented programming (OOP) and the resulting inability to map from an object-oriented design model. (Jeong et al. 2014)

Cunningham researched gbXML capability to transfer data between Revit MEP and Trace 700. He started by depicting the gbXML structure, how it organizes and represents the data, and typical challenges that are encountered creating accurate gbXML files. He also investigated the Extensible Markup Language (XML)

schema of gbXML and highlighted its properties. XML is a treelike hierarchy of *elements*; these elements have attributes and values within an enforced structure. He reported that gbXML structure ensures compatibility only if the sending application and the receiving application support the same XML elements. Only 62% of the elements supported by Revit MEP export mechanism were mutually supported by Trace 700; only mutually information is transferred, and that could explain part of the data loss (Cunningham 2009). For example, specific attributes defined in Revit such as the *Design Cooling Temperature* would therefore not be transferred, as this element is not supported by Trace 700 import mechanism.

Kumar investigated the interoperability gap between BIM and BEM. The intent of her study was to “test whether BIM software, specifically Revit, was robust enough to allow seamless interoperability with analysis programs such as Ecotect and IES<VE>” (Kumar 2008). Her research tested the data transfer, apart from geometry, using three neutral file formats: DXF, gbXML and IFC. Kumar’s research showed varying data loss between the properties of the selected families in Revit and their representation in IES<VE>. She then enhanced the Revit-IES interface by designing a “patch” file. This patch file was a Revit template that defined a set of Revit wall families that derived their values from the IES construction database and could be imported into a Revit project. By using the families identified in her patch file the user would be guaranteed an accurate precise data transfer between Revit and IES<VE>. The disadvantage of this approach is in its particular nature. It would only support a part of the data transfer and only when using those specific software programs and wall constructions.

Some researchers have expressed a preference for the gbXML schema over IFC. In their specific study it allowed for a less complex implementation for the development of their lighting schema and could carry building environmental sensing data although they conceded that IFC had a better approach for depicting building geometry (Dong, et al. 2007).

Howard and Bjork were harsh (or realistic) in their overview of the usefulness of IFC as a complete BIM standard citing numerous downsides including unrealistic view of a “single building model,” lack of use of standards, complexity of the definition, and others, but they did hold out hope that significant success by key pioneers could change this outlook (Howard and Bjork 2007).

Still others had little problems in using the IFC format: “Operations were developed to traverse the IFC building model structure and apply the described operations to each anomalous condition encountered. The corrected building model generates the proper geometry needed for the IDF input to EnergyPlus” (Sanguinetti et al. 2014). Others have embraced it use and proposed a methodology for implementation including “populating IFC-based BIM with data; automated rule-based data transformation; rigorous model checking; building energy performance simulation; and analysis of results from simulation.” (Bazjanac 2008) Other researchers are developing their own direct translators, for example from the Autodesk Revit software to the LBNL Modelica Buildings library (Yan 2014). Although of use in research, this is not a standard that could be used for wide spread industry adoption.

The common type of data models (IFC or gbXML) that BIM authoring tools export and the data models that the BEM tools import and export lead to the overall conclusion that gbXML is the preferred file format for data import (Fig. 2).

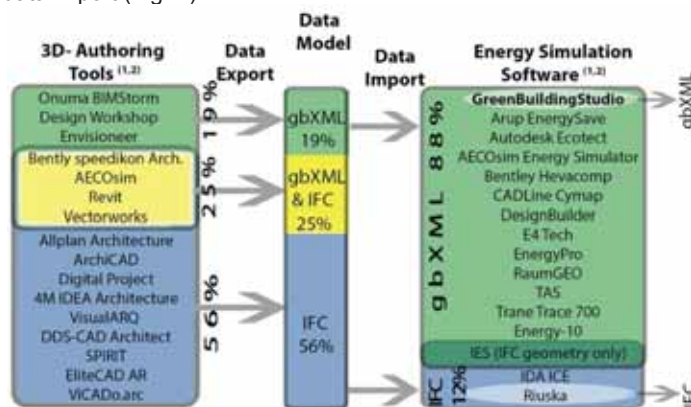

Figure 2: Types of data models (IFC or gbXML) that BIM authoring tools and energy simulation tools import and export; developed according to a web-search performed November 2014.

It is observed that neither IFC nor gbXML have unanimous software support to complete the data exchange. IFC has better support between the BIM authoring tools as 81% enable the export of data through it compared to 44% enable export through gbXML. While gbXML has better support between the BEM tools as 88% support its import versus only 12% are certified for IFC import. This means that the user has very limited options to transfer the data between BIM and BEM making the file transfer itself a challenge.

2.0 METHDOLOGY

The medium office building was chosen as the reference building. It was obtained from the U.S. Department of Energy (DOE) reference buildings website that contained IDF (EnergyPlus) descriptions for whole building energy analysis (DOE 2015). The office building is 3-storey, rectangular shaped with a steel frame structure and has continues strip windows with a 0.33 window to wall ratio. The IDF files from the DOE website specified all the relevant data relevant to energy simulation. These files were opened in EnergyPlus, and DXF files were exported with the geometry. The DXF files were imported into Autodesk Revit, both as a conceptual mass and detailed building model. The Revit model used slightly differs from the original IDF file (the area of the Revit model is 457m² versus 463m² in the original IDF file). This difference, however, will not affect the results as this deliverable is concerned with data transition and not the total energy consumption. A subset of critical parameters was chosen for testing the data transfer.

2.1. Case study building, subset of critical parameters

Critical parameters were selected to form a representative sample to determine whether or not the data was being transferred properly. The selected parameters covered various gbXML elements including: campus (location, building elements – areas, building story), space (ID, areas, volume), layer (R-value, thickness, conductivity, specific heat), window (overall conductance – U-Value, solar heat gain coefficient - SHGC, transmittance), and schedules.

2.2. Checking the building geometry for accuracy and completeness

The building model was inspected visually and numerically. The visual inspection compared the 3D model of both the DWG and the gbXML files using third party viewers. The numeric inspection verified that the area and volume of the model created in Revit remained the same in the gbXML export file and the BEM software interpretation of that gbXML file.

2.3. Checking the parameters for accuracy and completeness

The gbXML file data was compared against the original data input into Revit for the following divisions: a) location, building, and space elements; b) window and wall elements; and c) space attributes, density, load intensities, and schedules. The BEM software programs tested were Green Building Studio, EnergyPro, IES Pro, and eQuest.

3.0 RESULTS

The building geometry and a subset of data parameters were checked for completeness and accuracy.

3.1. Checking the building geometry for accuracy and completeness

None of the four energy simulation tools had the capability to import the DWG file, even minimally just to import the geometry.

Using gbXML the geometry visually imports correctly for this case study building, but with other building models users have reported missing surfaces, incorrect surface orientations, and other problems. These issues are sometimes due to a modeling or configuration error by the user, and in other cases it may have been an error in the export feature. McCallum of IES gave one example of a particular limitation with data models that did not work well with energy modeling requirements: “The geometry intended for energy modeling analysis –spaces and space boundaries- is drawn at the inside surfaces of walls and floors.” When that geometry is imported to the energy simulation tools the spaces are separated by air gaps (McCallum 2014). Having gaps, which should not be there, produces inaccurate results in the simulation. Other issues have occurred where window shades were being misinterpreted as roofing elements.

A further visual inspection was made to compare the geometrical representations of the gbXML and DWG files that are exported from the same model. To complete this, it was necessary to simplify the case study model and remove all the non-geometry data. First, a room made up of only walls with no floor or roof was modeled in Revit and then immediately exported into both gbXML and DWG. The DWG was directly imported into Sketch-up. To enable the import of gbXML file, gModeller was installed as an extension to Sketch-up. gModeller enabled the import of the gbXML file on the same project. The two models were then compared and found to be identical.

3.2. Checking the building data for accuracy and completeness (not geometry)

The gbXML file data was compared against the original data input in Revit, and the results are shown for the following divisions: a) location, building, and space elements; b) window and wall elements; and c) space attributes, density, load intensities, and schedules.

A) Location, building, and space elements

Green Building Studio, EnergyPro, and IES Pro generally worked well in importing the location, building, and space elements of the gbXML file. The weather file is not included in the gbXML data, and users are required to input it manually.

- The data was exported correctly from Revit to the gbXML file.
- Upon importing the gbXML file, EnergyPro and IES Pro translated the address of the project. However GBS required manual input of the address before even attempting to import the gbXML. eQuest does not have the capability to import a gbXML file.

B) Window and wall elements

There was sporadic success with transferring the attributes of window and wall elements with Green Building Studio and IES Pro performing much better than EnergyPro (Fig. 3).

	Window					Wall								
	Name	U-Value	SHGC	Window to wall ratio	Transmittance	Name	Layer 1							
							Name	Roughness	Function	Conductivity (W/m-K)	Density (kg/m ³)	Specific Heat (J/kg-K)	Thickness (m)	Thermal, Solar, Visible Absorbance
IDF File Data	Window Non-res Fixed	1.23646	0.25	33%	NO Value	Steel Frame Res Ext Wall	Wood Siding	Medium Smooth	Outside Layer	0.11	544.62	1210	0.01	Value
Revit	Socal Window	1.13	0.21	Inferred from Geometry	0.18 (default type)	Socal Steel Frame Non-res Ext Wall	Socal Wood Siding	NCT Entered	Exterior	0.11	544.62	1210	0.01	No reference
gbXML	Socal Window	1.13	0.21	Inferred from Geometry	0.18 (default type)	Socal Steel Frame Non-res Ext Wall	Socal Wood Siding	Function of the whole wall not layer	no reference	0.11	544.62	1210	0.01	No reference
Green Building Studio	Socal Window	1.13	0.21	Inferred from Geometry	0.18 (default type)	Socal Steel Frame Non-res Ext Wall	Socal Wood Siding	Function of the whole wall not layer	no reference	0.11	544.62	1210	0.01	No reference
EnergyPro	Socal Window	4.83	0.71	Inferred from Geometry	0.8	0.13 Wall	Default Wall with no reference to original wall in layers: Wood framed Construction: 2x4 @ 16"							
IES Pro	Socal Window	1.13	0.21 (factor) + 0.07 (factor) = 0.17	Inferred from Geometry	0.18 (default type)	Socal Steel Frame Non-res Ext Wall	Socal Wood Siding	Function of the whole wall not layer	no reference	0.11 (Btu.in/h.ft.F)	34 lb/cft = 544.62 (kg/m ³)	0.285 (Btu/lb.F) = 1210 (J/kg.K)	0.39" = 0.01 m	No reference
eQuest	Green's report gbXML													

Figure 3: The results of the exchange data of the window element and the wall assembly of the material element.

- The thermal data in Revit was exported correctly into the gbXML file. Roughness and function of layer data however were not exported, as they do not relate to thermal properties. The gbXML file does not attempt to export any data that is not related specifically to geometry or thermal properties.
- GBS and IES imported the building envelope data correctly from gbXML file, but EnergyPro did not. The attributes of the assemblies were changed to the default values of the software as if no data has been input into the building information model.

C) Space attributes, density, load intensities, and schedules

Revit exported the data into the gbXML file, but for the most part, these parameters were not imported into any of the energy simulation programs (Fig. 4).

	Zone (in revit called Space type) Setting						
	area per person	sensible heat gain per person	lighting load intensity	power load intensity	occupancy schedule	lighting schedule	power schedule
Green Building Studio	264 people	undefined	10.76 W/m ²	10.76 W/m ²	Re-enter in GBS	Re-enter in GBS	Re-enter in GBS
EnergyPro	8.22 m ² /person	131.86 W/person	8.5 W/m ²	undefined	undefined	undefined	undefined
IES Pro	undefined	undefined	undefined	undefined	On (permanently)	On (permanently)	On (permanently)
eQuest	Density Import gbXML						

Figure 4: The results of the exchange of data of the space attributes; people density, lighting and power load intensities, and building schedules. Only the imported values are shown.

4.0 DATA TRANSPARENCY TOOL (DTT)

4.1. Discussion

From looking at the results, a few findings are apparent about both the transfer of geometry and energy data. First, DWG is generally not a useful format for geometry transfer, not because it is not accurate, but because several energy programs do not import it. Second, gbXML is an adequate file format for this purpose but occasionally has problems with more complex or confusing geometry (for example, it might not be able to tell the difference between a window shade and a small roof). For data transfer, the results were worse. The gaps are both of inaccurate and incomplete transfer of data. It appears that the BIM authoring software export is functioning correctly to gbXML in most cases. However, the building energy software is not always taking full advantage of the information in the gbXML file to import it correctly. This may partially have to do with how the energy program is handling each specific piece of data as it is input.

To help alleviate some of these interoperability issues, it was decided to develop a tool that clearly showed what values were in a gbXML file. Unlike other gbXML readers, it would not show all the data in gbXML's hierarchy, but instead isolate the parameters that energy simulation software use and group them into the four DOE categories: *program, form, fabric, equipment* -- program (location, total area, internal loads, operating schedules, hot water demand, and ventilation requirements), form (geometry and orientation), fabric (construction types and thermal properties of the building elements), and equipment (the types, specification, and efficiency of the lighting, HVAC, and SWH systems) (Deru et al. 2011).

4.2. Features

The DTT's goal is to allow the user to verify the data in the data models and then correct inaccuracies. This is done by applying a transparency layer upon the IFC and gbXML files so that even the inexperienced user could understand them (Fig. 5). Three steps were needed to create the tool: matching gbXML elements with the selected variable set; creating a new XML schema that matches the variable set; and presenting the data in a Microsoft Excel tool that would automatically populate the data.

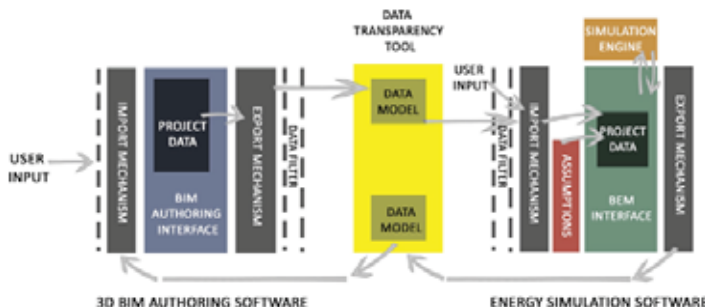

Figure 5: Diagram of the Data Transparency Tool (DTT)

The diagram of the BIM authoring software encompasses the user interface, import, and export mechanisms. The import and export mechanism include data filters that select partial data for export. When exporting from BIM to BEM not all the data in the model is exported because some of it is irrelevant. As an example of the filtering is the exclusion of elements such as furniture and attributes such as costs that are irrelevant for energy analysis, and therefore the software does not attempt to export them. The DTT sits between the BIM and the importing of the energy simulation software. In addition to the filters there are a set of assumption (defaults) that the BEM tool would use to fill out missing data in the data model and in some cases even override existing data in the data model. The tool could in the future also include a graphical comparison of the geometry being imported and exported. There are other tools for gbXML such as FZKViewer, DDS-CAD and plug ins such as gModeller plugin for Google Sketchup, but these are steered towards geometry visualization and not towards non-geometrical data representation.

4.3. Demonstration

A simple prototype of the tool was created. It was developed by creating a new XML schema that follows the hierarchy of variables defined by DOE. Using the new schema, the data is presented to the user in a Microsoft Excel interface. The original XML was accessed by opening a template gbXML file in Excel and accessing the source panel through the developer tab. The new XML schema was then created by dragging the element nodes from the *XML Source* pane to the workspace cells adhering to the defined variable set as basis for hierarchy. *Program, Form, Fabric* and *Equipment* therefore create the top levels of the hierarchy and encompass under them the related variables. This schema was then used to present the data model values. The Excel template contains four main tabs each of which corresponds with the variable set and its underlying elements. The user would simply import the gbXML file or IFCXML file to their corresponding DTT and the tool would automatically populate the values.

The final DTT is envisioned to eventually incorporate the following functions (Fig. 6).

- Import the different data models directly into the tool (gbXML, IFC).
- Present the variables under the hierarchy of building energy categories (Program, Form, Fabric, and Equipment) to quickly inform the user of the contents of the file.
- Provide a graphic representation of the 3D model.
- Create a color-coded visualization corresponding to the defined energy categories.
- Analyse the completeness of data and alert the user of any missing data necessary for BEM.
- Review and validate the data. Confirm the variables are within accepted variable range; for example the value of the Solar Heat Gain Coefficient (SHGC) should be within the range zero to one.
- Generate a score for the imported gbXML file depending on the completeness and validity of data.
- Compare two gbXML files. The intent would be to show the file export from the BIM authoring software versus the same file immediately exported from the BEM software (this can not be done until software companies include an export feature from their energy software)

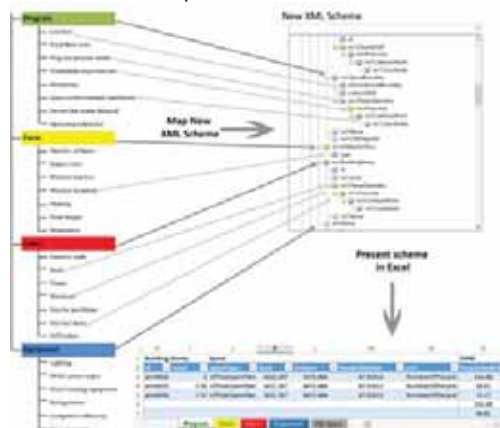

Figure 6: Diagram of methodology: mapping new XML schema based on the defined variable (left and upper right) and presenting the schema in the DTT Excel interface – partial screenshot (lower right corner).

CONCLUSION

BIM software should be able to export necessary information, and energy programs should be able to import it. This improves efficiency and frees up time that could be used for simulations to better the building design. The use of standard, preferably neutral file formats, would also allow the users to choose the appropriate software for their needs. The first step was to understand the current limitations of file transfer while

considering how the transparency of data and “open” structured BIM data can be used to help bridge many of the BIM gaps that exist in the handover of information. This was tested with a base case building and a selection of parameters in one BIM and four BEM software programs. It has been shown that the export features work (although the results are not transparent to the user), and that data is lost in the import to the energy software. The development of a data transparency tool could help solve some of these problems by showing the user in a simple manner exactly what is being exported from the building information modeling software and imported into the energy software; a prototype was created in Excel. Then designers could have more confidence about the values of parameters that are being transferred from BIM to BEM.

ACKNOWLEDGEMENTS

The authors wish to acknowledge SoCalGas, TRC Solutions, and Skanska for partial funding for the BIM to BEM research. Thanks also to Jeff Oullette for his input.

REFERENCES

- AIA. 2012. *An Architect's Guide to Integrating Energy Modeling in the Design Process*, <http://info.aia.org/aia/energymodeling.cfm>, last accessed 29 November 2014.
- Bazjanac, V., “IFC BIM-based methodology for semi-automated building energy performance simulation,” Lawrence Berkeley National Laboratory, <http://escholarsip.org/uc/item/0m8238pj>, 2008.
- Cunningham, P. 2009. “Heating and cooling load calculations and energy model development from an Autodesk® Revit® MEP model utilizing gbXML,” Autodesk University.
- Deru, M., Field, K., Studer, D., Benne, K., Griffith, B., Torcellini, P., Liu, B., Halverson, M., Winiarski, D., Rosenberg, M., Yazdani, M., Huang, J., Crawley, D. (2011). U.S. Department of Energy (DOE) “Commercial reference building models of the national building stock.” 1-118. 2011. NREL Report No. TP-5500-46861, http://digitalscholarship.unlv.edu/renew_pubs/44/?utm_source=digitalscholarship.unlv.edu%2Fnew_pubs%2F44&utm_medium=PDF&utm_campaign=PDFCoverPages, last accessed 16 September 2014.
- DOE, 2015. <http://energy.gov/eere/buildings/new-construction-commercial-reference-buildings>, last accessed 01/15/2015.
- Dong, B.; Lam, K.P.; Huang, Y.C.; and Dobbs, G.M., “A comparative study of the IFC and gbXML informational infrastructures for data exchange in computational design support environments,” *Proceedings: Building Simulation*, 2007.
- Gallaher, Michael P., Alan C. O'Connor, John L. Dettbarn, Jr., and Linda T. Gilday. 2004. Cost Analysis of Inadequate Interoperability in the U.S. Capital Facilities Industry. National Institute of Standards and Technology. http://www.nist.gov/manuscript-publication-search.cfm?pub_id=101287.
- gbXML, 2014. <http://www.gbXML.org/> and <http://www.gbxml.org/history.php>, last accessed 08/11/2014.
- GSA, 2007. “GSA Building Information Modeling Guide Series 01 - Overview DRAFT,” http://www.gsa.gov/graphics/pbs/GSA_BIM_Guide_v0_60_Series01_Overview_05_14_07.pdf, last accessed 16 September 2014.
- Hijazi, M. 2014. Interviewed Stephen McCallum on September 8, 2014.
- Howard, R. and Bjork, B.C. 2007. “Building information models – experts’ views on BIM/IFC developments,” *Proceedings of the 24th CIB-W78 Conference*.
- Jeong, WoonSeong, Jong Bum Kim, Mark J. Clayton, Jeff S. Haberl, and Wei Yan. 2014. “Translating Building Information Modeling to Building Energy Modeling Using Model View Definition.” *The Scientific World Journal* 2014 (September): e638276. doi:10.1155/2014/638276.
- Kensek, K., Becker, G., and Hijazi, M. 2014. “BIM Gaps: major issues that are preventing seamless integration of building information modeling in the AECO industry,” white paper.
- Kumar, S. 2008. *Interoperability between Building Information Models (BIM) and Energy Analysis Programs*, Master of Building Science thesis, University of Southern California. <http://digitallibrary.usc.edu/cdm/ref/collection/p15799coll127/id/64743>, accessed September 4, 2014.
- Sanguinetti, P.; Paasiala, P.; Eastman, C. 2014. “Automated energy performance visualization for BIM,” *Building Information Modeling: BIM in Current and Future Practice* [editors Kensek, Noble], Wiley.
- Srinivasan, R., Kibert, C., Thakur, S., Ahmed, I., Fishwick, P., Ezzell, z., and Lakshmanan, J.. 2012. “Preliminary Research in Dynamic-BIM (D-BIM) Workbench Development.” In *Proceedings of the Winter Simulation Conference*, 53:1–53:12. WSC '12. Berlin, Germany: Winter Simulation Conference. <http://dl.acm.org/citation.cfm?id=2429759.2429828>.
- Yan, W. 2014. “Parametric BIM SIM: integrating parametric modeling, BIM, and simulation for architectural design,” *Building Information Modeling: BIM in Current and Future Practice* [editors Kensek, Noble], Wiley.

Building performance analysis considering climate change

Yiyu Chen¹, Karen Kensek¹, Joon-Ho Choi¹, Marc Schiler¹

¹University of Southern California, Los Angeles, CA

ABSTRACT: Climate change will significantly influence building performance in the future both through differences in energy consumption (perhaps drastically in certain climate zones) and by changing the thermal level of comfort that occupants experience. A building that meets the current energy consumption standard has the potential to become energy inefficient in the future, and well-meaning designers might be applying passive strategies for current conditions without understanding what impact their choices have under different climate change scenarios for their location. By analyzing a case study building's thermal performance, specifically lifecycle energy use, for multiple climate change scenarios and in different climate zones, it is possible to inspect the resilience of passive design strategies over time. Varying the solar heat gain coefficient (SHGC) was the first strategy tested. To estimate the building's future performance, three projected future climate conditions were created (for low, moderate, and severe climate change) in three climate zones for three different time periods (2020s, 2050s, and 2080s). The first step was to create new projected weather files. They were calculated from a world climate change weather file generation tool that was developed at the University of Southampton. Then the weather files were used in EnergyPlus to determine the energy consumption. Aggregated multiple runs provided lifecycle energy use for each of the three locations. Then the SHGC values were varied to determine which initial values provided the best long-term result. Although currently only SHGC was tested, this research provides a methodology for architects and engineers during the early stage of design that they can use to avoid the detrimental consequences that might be caused by climate change over the lifecycle of the building. Another result of the study was a better understanding of the shifting of the ASHRAE climate zones.

KEYWORDS: Climate Change, Climate Zones, Energy Performance, Passive Strategies, Weather Files

INTRODUCTION

Sustainable design requires that architects and engineers fully understand the interaction between climate, as encoded in a weather file, and the predicted building performance. However, it is easy for designers when running computer simulations to overlook that climate is a dynamic system. Research into building lifecycle energy use considering non-static weather conditions can provide designers valuable recommendations that they can use during the conceptual design stage to help the decision making process. This type of integrated design process can better ensure the building performance is not just for code compliance or even for lessening current energy consumption, but takes into account future climate conditions.

1.0 RELATIONSHIP BETWEEN BUILDING PERFORMANCE AND CLIMATE

It is estimated that buildings are responsible for 40% of total energy consumption (SBCI, 2009) and 72% of the total electricity use in the world, which makes structures one of the main causes of world energy depletion (Action Energy, 2003). Building performance relies on two main factors: the building's properties and the weather conditions. Either of these two factors will affect the performance analysis results. Predicting future building performance requires the use of simulated, "future" weather files, and assuming the building stays the same throughout its life, the influence of building's properties alone can be tested, and recommendations to avoid negative effects can be provided.

1.1. Building energy simulation overview

Building energy simulation is used to predict and analyze building energy use before the building is constructed. Energy modeling is based on a virtual description of the geometry and building physics (properties); it relies on a simulation engine (such as DOE 2) and often a second software program that provides a user interface. Building energy simulation is widely used in the architecture industry. It is one of the two paths that help designers evaluate their projects and achieve code requirements or pursue a sustainability certificate. One path is *prescriptive design*, where specific requirements have to be met (e.g. a specific R-value of insulation in the walls) to achieve the code requirements and building energy efficiency. The other path is *whole building energy simulation*, which allows designers to rely on software results to evaluate building energy performance. In the latter method, there is more freedom in the choices, but there

is still an energy allowance that has to be met depending on state and local codes. In either case, the critical point is that for both prescriptive methods and energy simulation, predicted performance is based on current climate conditions (in the weather file) and not future climate conditions. Buildings that appear to meet or exceed base building performance now may not in the future.

1.2. Climate change

Many phenomena have been observed by researchers that support the theory of climate change (<http://www.epa.gov/climatechange/>, <http://climate.nasa.gov/>, <http://www.ipcc.ch/>). Building performance will be influenced by climate change, since buildings are sensitive to their local microclimate. For example, some buildings in Europe has already experienced overheating issue in the last several years due to increasing temperatures (Hulme et al., 2002). Climate should not be considered as a static value when analyzing building performance as buildings are in use over decades, sometimes even centuries. Instead, climate is a critical variable that should be considered for reducing the risk of poor building performance in the future (e.g. high energy consumption) and to make the building more resilient over its lifetime.

1.3. Weather file and its role in energy simulation

A weather file is a record from a weather station that contains very detailed data for a specific location. There are many different types of weather files serving different purposes. A TMY (Typical Meteorological Year) file contains the monthly weather (with hourly values recorded) selected from different years to represent a “typical” weather condition throughout a year; it is not the representation of any one specific year. A TMY3 weather file’s data is not derived to represent the weather extremes and is not suitable for building system design. Other weather file types are more suitable for system design as the extremes have not been “averaged out.” However, a TMY 3 weather file does have diurnal and seasonal variations that represent a typical year’s climate condition for that location. (Wilcox and Marion, 2008). It represents a typical weather condition over a long period of time, such as 30 years (Marion and Urban 1995). There are three different types of TMY weather files: TMY3 = 1976 -2005, TMY2 = 1961-1990, TMY = 1952-1975 (Holmes and Ap 2011).

Based on the future weather variables projection considering the IPCC climate change scenario, the UK Climate Impacts Programme in 2002 (UKCIP02) proposed that the 15 weather variables will be different in the future including maximum, minimum, and mean temperature; specific and relative humidity; 10 mile wind speed; net surface longwave and shortwave flux and total downward surface shortwave flux; soil moisture content; mean sea level pressure; surface latent heat flux; total precipitation and snowfall rate; and total cloud in longwave radiation (Belcher, Hacker, and Powell 2005).

1.4. Life-cycle energy use

Life-cycle energy use will be used as to evaluate the building energy use. It reflects the building energy consumption during its entire life cycle. Energy Use Intensity (EUI) is not applicable in this case since the climate change is going to result in a different EUI year by year, and it is necessary to take the total energy use for a building’s entire life cycle to determine if the building is consuming more or less energy over time (EUI_{LC}).

2.0 FUTURE WEATHER FILES

Current TMY files will be used as the basis for creating the “future” weather files using the HadCM3 climate model and pattern scaling.

2.1. HadCM3 and pattern scaling

Many climate change models have been developed to represent the changed patterns and predict the future possible climate conditions. The HadCM3 model has been used to explore climate change’s impact on different building types (Wang and Chen, 2014). The model was developed at the Hadley Centre in the United Kingdom (Collins, Tett, and Cooper, 2001). Two advantages with this model make it appropriate for building energy use: it has a relatively smaller grid spacing than some others, which means the simulation resolution is higher than other models and results in higher precision, and it has also adopted in IPCC for future global warming trend projection. The model was used by the IPCC to represent recent temperature from a 1961 – 1990 average.(Hulme et al., 2002)

Based on the HadCM3 climate change model, it is possible to project the future climate weather from TMY weather files. The weather data generated from existing tool developed at the University of Southampton is used only for one scenario, which is “medium high emission” (A1) (Hulme et al., 2002). It is important to determine more scenarios (such a low, medium, and high emissions) so that the impact of climate change can be studied more comprehensively. To derive climate data for the other three scenarios, pattern-scaling is used, which uses factors that are associated with the magnitude of each scenario. Uncertainties are

unavoidable, but assessments of the pattern-scaling technique have concluded that it is reasonable to make these assumptions for the present generation of General Circulation Models (GCMs) (Hulme et al., 2002).

2.2. Creating the weather files

The core of climate change building energy simulation is the weather file, since every calculation and the simulation is based on this file. A convenient representation of this data is the spreadsheet. However, the file initially generated from the spreadsheet is not a usable weather file; it is necessary to convert the file to other format which can be read by energy simulation software, the EPW format. The tools that were used for conversion are “CC world weather generator” and the EnergyPlus weather file convertor. After generating the new weather file, the heating degree day (HDD) and cooling degree day (CDD) values were calculated.

The first step was to create a weather file for every emission scenario. According to the IPCC climate change model HadCM3, the future climate condition is simulated based on four different emission scenarios, which are B1-Low Emission, B2-Medium Low Emission, A2-Medium High Emission, and A1F1-High Emission (Barker 2007). However, the “CC world weather generator” developed at the University of Southampton is only able to calculate the future weather condition for scenario A2(Jentsch, Bahaj, & James, 2008). Several projections of future climate for 2020s, 2050s, 2080s can be made (each with low, medium, and high emissions) (Belcher, Hacker, & Powell, 2005). Four additional emission scenarios were calculated using pattern scaling. Pattern scaling is based on a series of factors that provide a magnitude for the change (Table 1). Although derived for the UK, the method is appropriate even if new factors are determined later either due to more accurate predictions or better location sensitive values.

Table 1: Pattern scaling factors (Hulme et al., 2002)

Time-Slice	Low Emission	Medium-Low Emission	Medium-High Emission	High Emission
2020s	0.24	0.27	0.27	0.29
2050s	0.43	0.5	0.57	0.68
2080s	0.61	0.71	1	1.18

By using the pattern scaling factors, it was possible to generate weather files for the other three scenarios for each time-slice in the weather file by calculating the magnitude of change for each weather parameter.

2.3. Climate zone map example

An additional use of the “future” weather files (when completed for thousands of locations) will be to create a new climate zone map of the United States. The climate map is used for building performance analysis, since the determination of some characteristics of the building are selected based on the climate zone that it is located in. For example, the determination of solar heat gain coefficient (SHGC) is based on the climate zone designation.

The most commonly used climate map for United States is ASHRAE (or IECC) climate map, in which the entire U.S is divided into seven climate zones based on the temperature difference, the numeral letters in a climate zone name represent the heating degree day and cooling degree day, which are used to determine the temperature division of a place (Fig. 1). Climate zones are not the best characterization of the variety of climates that exist in the U. S. (for example, there are only 7 zones in the US plus an indicator for marine conditions), but these climate zones are referred to in ASHRAE 90.1 to provide guidance for architects and engineers design decision making and also play a role for projects pursuing LEED certification.

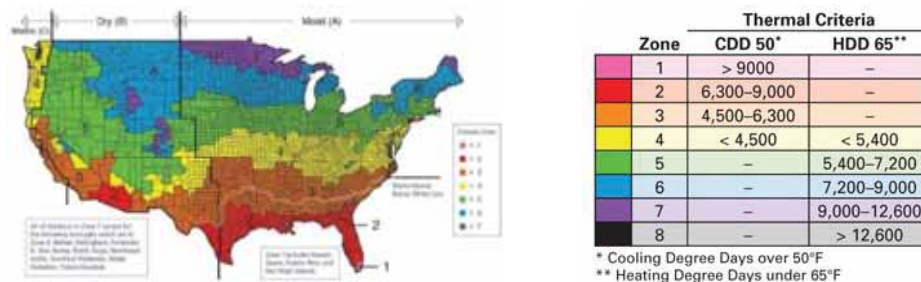

Figure 1: The ASHRAE (or IECC) climate zone map for United States (DOE, 2010)

Since the designation of climate zone is based on the CDD and HDD, it is possible use the “CC world weather generator,” “Emission scenario generator,” EnergyPlus weather file convertor, and the definition of

climate zones 1 – 7 to create a new climate map for a specific future time. A test was done using seven counties in California at different latitudes. Generally, each county shifted from current climate zone to the next level (Fig. 2). Eventually the sequencing will be automated so that a climate zone is determined for each county in the U. S., and a map will be created.

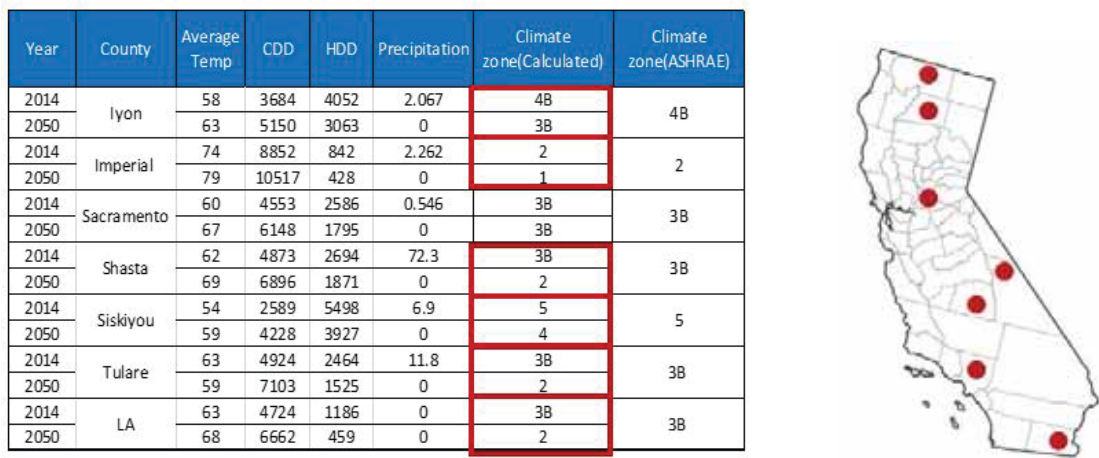

Figure 2: Highlighted counties have new climate zones (left) and their locations in California (right)

3.0 METHODOLOGY DEMONSTRATION

A climate zone map is a useful graphic for envisioning climate change, but was not part of the methodology for testing future climate on the long-term effectiveness of passive strategies. The workflow for the building lifecycle energy use study was as follows: create many new weather files and baseline buildings (one for seven ASHRAE climate zones) and then run simulations for the applicable variables (Fig. 3).

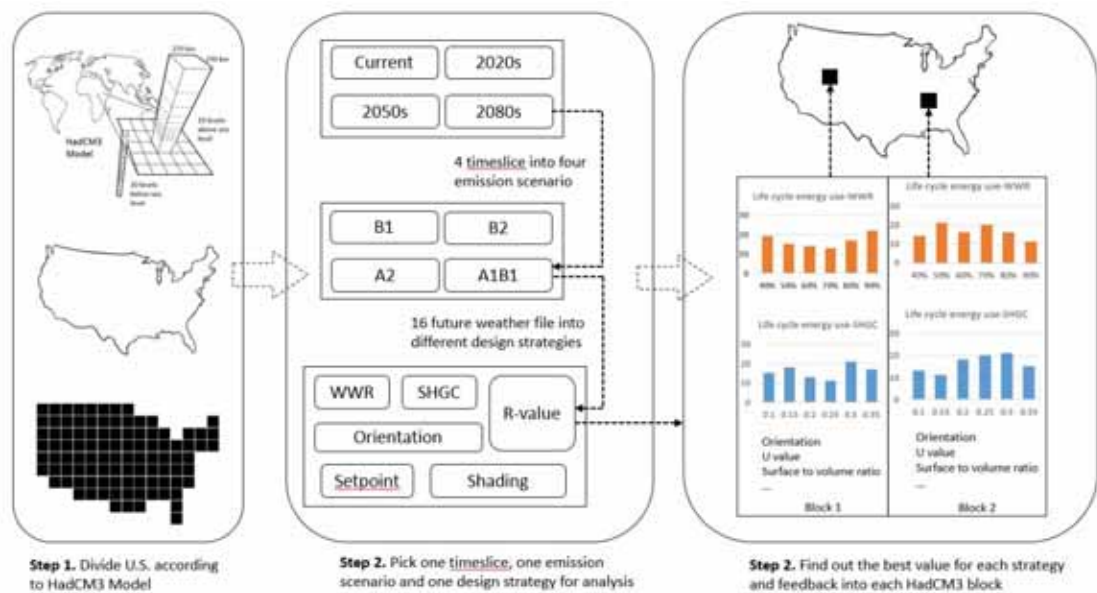

Figure 3: Workflow of building life cycle energy use calculation

3.1. Baseline building

Several baseline buildings were considered. For example, if the study only focused on California, Title 24 should be the best reference since it has prescriptive design requirements that can be used as the default model information. However, since the analysis is across the U.S. and seven climate zones, the reference selected was ASHRAE 90.1 because it includes detailed requirements for each climate zone. ASHRAE 90.1

Appendix G specifically addresses the development of a baseline model, which will be used to compare against the proposed model simulation result (ASHRAE, 2007). A medium office building was chosen (a three storey office building with 33% window-to-wall ratio; the total floor area is 53,600 square feet). It is included in the prototype baseline model package downloaded from the DOE website (<http://www.energycodes.gov/commercial-prototype-building-models>).

This model was used for the initial testing and will be used for the continuing study of different passive strategies for each climate zone and each U. S. county. The geometry will stay the same throughout the entire process. However, the building variables will be different for each climate zone to create another baseline model that meets the AHRAE 90.1 standards and has specific requirements for the building in different climate zones. For example, the wall construction, fenestration, system type, and others will be changed. The demonstration of the methodology used the solar heat gain coefficient (SHGC) as the variable.

3.2. Creating climate change scenarios

“CC world weather generator” is a spreadsheet based software that allow users to generate future weather for a known current weather file. In the interface of the software, users are required to complete three steps in order to generate future weather file:

1. Select a weather file
2. Select a time slice among 2020s, 2050s, and 2080s
3. Generate weather file

This software is only able to generate one emission scenario for each time period, which is A2 (medium high emission scenario). Therefore, with the pattern scaling method provided from IPCC report, it is possible to develop a spreadsheet that can further convert the A2 scenario based weather file to future weather files based on other emission scenarios (B1, B2 and A1F1) (Hulme et al., 2002).

3.3. Sensitivity testing

Before the analysis, it is necessary to find out the sensitivity of the variables to make sure that there will be a noticeable change in the results. The first variable is the weather file, since the weather file plays a key role in studying the future climate condition. For each specific location, 16 sensitivity tests were done to provide a more comprehensive understanding of the climate change’s impact in the future; this ranged from the lowest impact (B1 scenario in 2020s) to the highest impact (A1F1 scenario in 2080s). Since the influence of climate change is different from place to place, the sensitivity of climate change should be different. Therefore, it is necessary to test more locations. Two locations were selected: Los Angeles and Boston. The two cities are representative of two very distinct sets of climate characteristics, which are hot-dry, hot-humid and cold- dry. Each time-slice will have four emission scenarios, and in total, there are three future time-slices plus the current year. Even though only two cities will be address at this moment, the third city will be added to take account of the cities in those hot and humid climate condition.

In addition, the sensitivity for each weather variable will help to decide which variables have more influence, since it is not necessary to analyze the parameters that have no any impact on building energy use when the climate changes. The internal factors can be excluded from the climate change related study since the internal load does not respond to the outdoor environment. For example, there is no need to analyze the occupant schedule’s response to climate change, since the building occupant profile is determined by the building type rather than climate condition.

The building façade features are sensitive variables to climate change because different weather conditions will generate different loads based on the building façade. For the initial demonstration, solar heat gain coefficient (SHGC) were chosen to test the methodology.

3.4. Energy use analysis

3.4.1 Baseline building analysis

The selected baseline building is the ASHRAE office prototype building. The building is three stories tall, the total floor area is 53,600 ft² with 33% window to wall ratio. The default zoning method was to separate the each floor into two parts, the perimeter zone and core.

To generally understand the climate change’s impact on building future energy use, seven California counties, from low to high latitude, were used first to test the methodology for the 2020s, 2050s, and 2080s, so that a general trend of the future building energy use could be seen. For each time slice, the selected emission scenario was A1F1, which was the worse case. Because heating and cooling energy account for a large portion of the building total energy consumption, the results show the change for cooling, heating, and

combined. For the counties at low latitudes, the building energy use will increase, and the 2080s scenario has the highest heating and cooling energy use. The highest increase will happen in Los Angeles at 2080s (40% increase). However, for the counties at high latitude, the heating and cooling energy use is actually decreasing in the future and most significant decrease is 15% for office in Siskiyou in 2080s (Fig. 4).



Figure 4: Future heating and cooling energy for office building in selected counties

3.4.1 Solar heat gain coefficient and future building energy use

The selection of solar heat gain coefficient (SHGC) depends on the location of the building. SHGC is a value that reflect glazing’s capability to transmit solar radiation from the exterior environment to indoor space (Bhandari and Bansal, 1994). The higher the value of SHGC, the better the glass can transmit the solar radiation, and the indoor space will experience a higher cooling load. Generally, a high SGHC is desired in cold locations where the extra heat is needed during the winter, and a lower SHGC is desired in hot areas to block radiation in the summer could increase the cooling load and building energy use. Since the SHGC reflects the glazing’s capability to transmit solar radiation, it is closely related with application of passive strategies. One passive strategy that is highly relevant to this coefficient is passive heating in the winter. By increasing the SHGC value, the glazing’s ability to transmit solar radiation is improved, which will allow

radiation transmitted to the indoor environment, and the heating load during the winter can be reduced. (Bhandari and Bansal, 1994)

The selection of SHGC impacts the building life cycle energy use. The question is for each location, is it a beneficial or detrimental in the long term to have a higher or lower SHGC for the initial condition assuming that it cannot be changed over time?

Unlike the selection of seven counties to understand the climate change's overall impact, the selected two cities were Los Angeles and Boston for testing SHGC. Not only do they have very distinct climate conditions, but the long-term goal is to use this methodology for many cities to test several passive strategies. Los Angeles is hot and dry throughout the year, while Boston is cold and dry during the winter. The selection of SHGC and the lifecycle energy use should be very different for these cities.

The lifecycle energy use is calculated based on the total energy use from the current year to 2080 using the Medium-High Emission scenario. Intermediate values were calculated for 2020 and 2050 with the energy used between each pair of time-slices assumed linear (this will be further refined later). The total energy for a building's life cycle is the shaded area (Fig. 5).

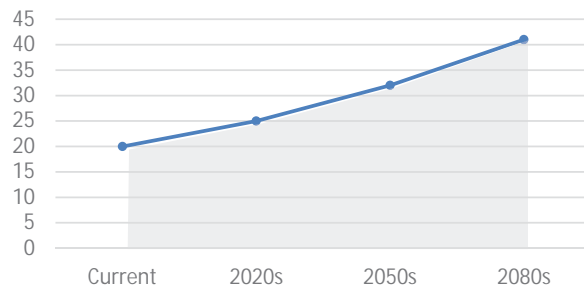

Figure 6: Calculation method for lifecycle energy (shaded area under curve)

For Los Angeles (climate zone 3, hot-dry) and Boston (climate zone 5, cold-dry) the values of SHGC were based on ASHRAE 90.1, which provides the maximum value of SHGC for climate zones 3 and 5. For Boston it is 0.4, and for Los Angeles, the value is 0.25. The study selected different values for comparison and an "optimized" SHGC value was found that had the lowest building life cycle energy use. For Los Angeles, the lower SHGC is always better for building energy efficiency; however, for Boston, the best value 0.7, which will have a 15% decrease of heating and cooling life cycle energy use compared against ASHRAE 90.1 standard (Fig. 6, Fig. 7).

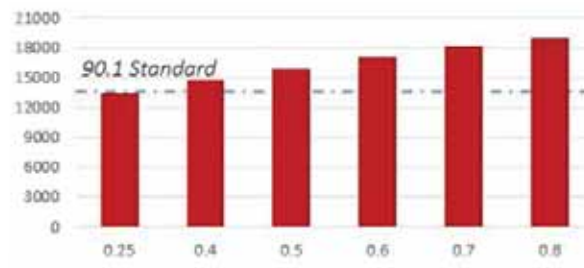

Figure 6: Life cycle heating and cooling energy use for different values of SHGC, Los Angeles

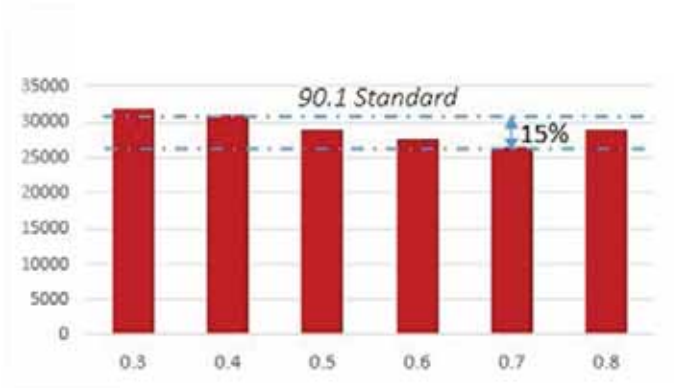

Figure 7: Life cycle heating and cooling energy use for different values of SHGC, Boston

3.4. Conclusion

Two methodologies have been presented. Both use the HadCM3 climate change model. The first was to demonstrate how to create a new climate zone map for the U.S. Several counties in California were used as case studies to show that changing climate will effect climate zone designations, which also effect the building performance predictions. The second was an initial demonstration of determining what passive strategies chosen by the designer now will have the best payoff in the future under different climate change scenarios. SHGC was tested for Los Angeles and Boston; it was determined that the lower SHGC, the better for Los Angeles, and a value of 0.7 for Boston is best for life cycle energy savings (heating and cooling). This methodology will be applied to a half dozen different variables that reflect passive strategies across multiple climate zones. The final analysis will determine which strategies are most suitable for long term benefit (low life-cycle energy use) for different climate zones considering climate change.

ACKNOWLEDGEMENTS

The authors wish to thank Greg Collins for his advice.

REFERENCES

- Action Energy .2003. "Energy Consumption Guide: Energy Use in Offices", 3483–3489.
- ASHRAE 2007. ASHRAE/IESNA 90.1 Standard-2007, "Energy Standard for Buildings Except Low-Rise Residential Buildings." *American Society of Heating Refrigerating and Air-Conditioning* 2007.
- Belcher, S., Hacker, J. and Powell, D. 2005. "Constructing design weather data for future climates." *Building Services Engineering Research and Technology*, 26 (1), 49–61
- Bhandari, M. and Bansal, N. 1994. "Solar heat gain factors and heat loss coefficients for passive heating concepts." *Solar Energy*, 53(2), 199–208.
- Collins, M., Tett, S., and Cooper, C. 2001. "The internal climate variability of HadCM3, a version of the Hadley Centre coupled model without flux adjustments." *Climate Dynamics*, 61-81.
- DOE. 2010. "Guide to Determining Climate Regions by County" Pacific Northwest National Laboratory & Oak Ridge National Laboratory, 2010
- Hulme, M., Jenkins, G.J., Lu, X., Turnpenny, J.R., Mitchell, T.D., Jones, R.G., Lowe, J., Murphy, J.M., Hassell, D. Boorman, P., McDonald, R. and Hill, S. (2002) Climate Change Scenarios for the United Kingdom: The UKCIP02 Scientific Report, Tyndall Centre for Climate Change Research, School of Environmental Sciences, University of East Anglia, Norwich, UK. 120pp
- Jentsch, Bahaj, and James 2008. "Climate change future proofing of buildings—Generation and assessment of building simulation weather files" *Energy and Buildings*, 40(12), 2148-1268
- SBCI, 2009. "Buildings and climate change: a summary for decision-makers " *Programme, Sustainable Buildings and Climate Initiative* Retrieved from
- Wang, H. and Chen, Q. 2014. "Impact of climate change heating and cooling energy use in buildings in the United States." *Energy and Buildings*, 82, 428–436.
- Wilcox, S. and Marion, W. 2008. May. "Users manual for TMY3 data sets users manual for TMY3 data sets."

Climate-responsive evidence-based green-roof design decision support protocol for the U.S. climate

Spurthy Yogananda¹, Joon Ho Choi¹, Douglas Nobles¹

¹University of Southern California, Los Angeles, CA

ABSTRACT: A number of trends have recently emerged in the areas of environmental building designs and high-performance systems. However, in spite of many design and technical efforts to improve building performance by using multiple building enclosure components, especially green roofs, the uncertainty of existing mechanisms, such as pre-defined computational modeling and design guidelines, has frequently resulted in lower performance efficiency than intended by the design. In reality, examination of many actual green roof performance cases revealed an even larger energy usage and/or lower environmental performance of the buildings, where implemented, than those of the adopted base cases. To address this challenge, we established a methodology for Climate-Responsive Evidence-Based Green-Roof Design Decision Support Tool that uses finely tuned performance modeling with calibration by the actual measured data from existing best practices. By utilizing these composite best-practice cases as a source for reference data, this project would be able to provide stakeholders (e.g., architects, facility managers, building / roof engineers, owners, etc.) with readily applicable and reliable green roof design solutions for new / renovation projects. To develop a design solution algorithm, multiple computational data mining methods and performance simulation modeling will be adopted. This project approach can lead to effective green roof design decisions in an early stage of an individualized project in various climates and under different geometric conditions, based on integrated principles of design and building architectural configurations. This will ultimately lead to better Urban Heat Island (UHI) effect mitigation.

KEYWORDS: Calibration, Simulation, High performance system, Urban Heat Island.

INTRODUCTION

A green roof is any roof, which usually, consist of plants growing on them but they perform just like any other roof. The important role of a green roof like any other roof is to provide shelter from heat, cold, snow, rain and wind. A green roof is nothing but a convection roof which consists of soil and plant layers along with the waterproofing membrane. Green roofs as mentioned before depends on various parameters like the composition of a green roof, insulation, vegetation type (extensive or intensive). All these parameters vary and are influenced by the climate zone they are located. Designers, Contractors and Clients although understand the importance of a green roof, they don't have much needed knowledge regarding the variation in green roof construction with respect to the climate to benefit the maximum savings on energy in terms of energy. Having the right knowledge about the variations in the green roof construction based on climate zones they are located in can benefit in terms of energy saving and in turn making it more economic. This can overall increase the growth in the construction of green roofs across the globe. This research is going to be based on various parameters involved in the designing of a green roof to reduce the heating or cooling load on the building in multiple climatic conditions in the U.S. For the climate selection, I have chosen Los Angeles classified as hot and dry (DOE climate zone (CZ #3), Missouri which is humid (CZ #4). Since green roof depends on soil composition, plant type, climatic condition, etc. On-site measured data is going to be collected and simulated performance data. The study will show how the climate influences the composition of a green roof and then will arrive at a basic conclusion on what a green roof composition should consist of based on the climatic zone based on accurately calibrated performance models using the measured raw data. The research will include simulation model calibration to estimate energy and environmental performance of green roofs in a few climates of the U.S.

1.0 OBJECTIVES

Rise in energy cost of a building, gave rise to increase in green roofing system. Although green roof has many advantages, like reducing UHI, improving air quality, storm water runoff etc. My research aims at studying the impact of reducing the load of a building by green roofs in the chosen climate zone.

- 1) Effectively model green roof assemblies for a building, in an energy modeling program, and calibrate those models based upon the use of existing data collected from a selected reference site.
- 2) Identify the role of the different parameters of a green roof assembly and quantify their impact on a building's heating and cooling loads.
- 3) Determine if a green roof (as a roofing option for different climate types) is a better alternative for cooling a roof, in terms of the thermal performance of the building.
- 4) Estimate the environmental performance and water usage/ quality management based on the evaluated energy performance and design configurations.
- 5) Develop the research findings in the form of a web-based decision support tool that is accessible to the public.
- 6) Facilitate and undertake further tool development as a means of opening new avenues of meaningful research with respect to evidence-based high-performance design.

2.0 PROJECT METHOD

As a step towards the research goal and objectives of this proposal, the project design and methods will include four steps: 1) Roof modeling and calibration, 2) Roof parametric data analysis, 3) Thermal and environmental performance, and 4) Development of a design decision tool.

2.1. Roof modeling

Two climate zones from United States were chosen to study the green roofs with respect to climate. The chosen climate zones were climate zone 3, which is hot dry and climate zone 4, which is humid. Two places in the chosen two climate zones were selected, namely California and Missouri. Temperatures at different levels of green roofs in the selected climate zones were collected over a period of 4 to 15 days in both California and Missouri, using various sensors and the data as recorded.



Figure 1: Represents the various climate zones.

2.2. Selecting the site to place sensors

Site in California:

The site chosen in California was, the Burbank Water and Power Building, located in Burbank. Burbank has a Mediterranean climate. The building was two story, constructed in 2012. It is LEED Platinum certified building.



Figure 2: Green roof on Burbank Water and Power Building (California).

Site in Missouri:

The site chosen in Missouri was, Emerson Electric Company Hall at the Missouri University of Science and Technology in Rolla, Missouri. The climate is humid subtropical, with 1227 mm average annual rainfall. As part of the roof renovation, a GAF Gardenscapes green roofing system with an area of 3,245 sq. ft was installed in the year 2013.



Figure 3: Green roof on Emerson Electric Company Hall (Missouri).

2.3. Checking for errors in the sensors

The sensors used in collecting the data in Burbank was the HOBO, It was important to check for the errors in the sensors before placing them to record data. Hence, all the HOBOS used for recording the data was placed together in a place, the data was recorded every 10 minutes over a period of 48 hours and then checked for errors. The graphs of the data showed uniform temperature and humidity reading. The maximum temperature difference between the sensors was .02 degree F, proving that the sensors could be used, since none of them showed no errors and the temperatures recorded by them were almost constant.

The sensors used in collecting data in Missouri were the Thermocouples, The thermocouples were prepared by exposing an inch of wire at one end, wrapping the two metals together, binding them with a blow torch, and then covering the probe tip with plastic dip paint. Due to the large scale of the project and varying locations of the probes, the lengths of thermocouple wire used vary from 25' to 235'. In total, around half a mile of thermocouple wire was used. The wide variety of lengths necessitated that the measurements be calibrated so as to eliminate any inconsistencies in the temperature readings resulting from the differences in wire lengths. To do this, the wires were left overnight while a data logger recorded temperature data at 3-second intervals. A graph of this data showed the thermocouples slowly approach a uniform temperature reading. Once this uniform reading was reached, the small differences among each thermocouple were taken as offset values (Stuart Baur, Investigating and Analyzing the Energy Performance of an Experimental Green Roof System Installed on an Institutional Facility 2013)

2.4. Placing of sensors and a data collection

Placing the sensors in Burbank, California

First, the green roof in the Burbank was divided into two parts the vegetative and the non-vegetative part. The non-vegetative part consisted of the glass decoration which were placed on the roof. The sensors were placed at various levels of both the vegetative and non-vegetative part of the green roofs. In the vegetative part of the roof the HOBOS were placed 2 feet above the green roof surface, to capture ambient air temperature on the surface of the green roof, beneath the soil at a depth of 4 inches and another HOBO was placed below the concrete surface from inside of the building has shown in the *figure* below . Another sensor was placed at the working level inside the building. The HOBOS used on the surface of the soil and green roof were covered with aluminum papers to reduce the impact of solar radiations on the temperature reading. The HOBO under the soil was placed in a plastic bag, with holes for the air to pass.

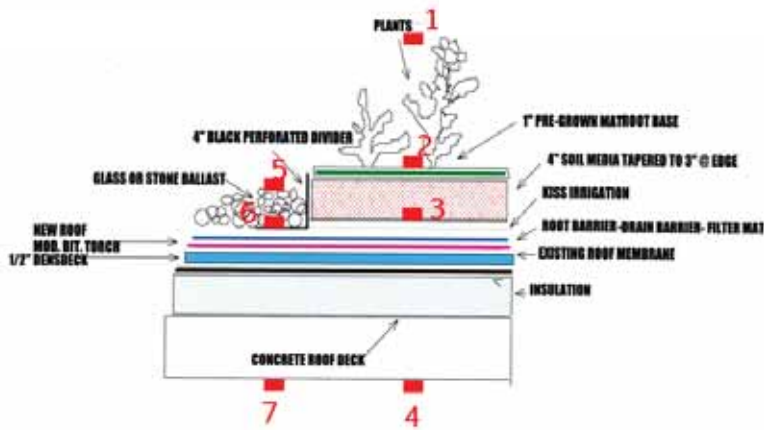

Figure 4: Section of the green roof showing all the placements of sensors.



Figure 5



Figure 6

Figure 5: The sensor placed to measure ambient temperature and humidity.

Figure 6: The sensors placed below the slab to measure the concrete temperature.

In the non-vegetative part of the green roof, HOBO was placed on top of the glass decorations which was again covered with aluminum paper for the same reasons as mentioned above, below the glass decorations again placed in a plastic bag with holes for the air to pass and to the concrete surface beneath the green roof area from inside of the building.



Figure 7: The sensor placed on the glass material wrapped in aluminum paper.

The sensors recorded the Temperature and Humidity over the next 15 days for every 30 minutes.

Placing the sensors in Rolla, Missouri

The experimental setup in Rolla consisted of three primary sources of data collection: The thermocouples for temperature measurement, a heat flux sensor, and a weather station. Two probes were placed at each levels of a green roof, 2' above the black roof, 4" beneath the green roof soil, and 2' above the green roof. One probe was placed at the remaining locations: the surface of the green roof, and on the underside of the concrete slab beneath, the green, roof sections (figure_4).

To capture the ambient air temperature 2' above each roof surface, three identical stands were built out of pressure treated 2x4 and weighed down with either sandbags or concrete blocks (figure_5). To isolate the thermocouples from wind and solar radiation, they were placed inside a double layer of plastic containers.

The inner layer protects the thermocouple from the wind whilst allowing some airflow through small openings. The larger outer layer is spray painted white to so as to reduce the impact of solar radiation on the temperature reading. (Stuart Baur, Investigating and Analyzing the Energy Performance of an Experimental Green Roof System Installed on an Institutional Facility 2013)



Figure 8: The sensors placed at different levels in the green roof.

For the temperature readings on the underside of the concrete roof slab, the thermocouple probes were placed directly on the concrete. A 6" square piece of one inch thick r-board was pressed up against the probe to isolate it from the temperature of the air space below. The blocks and probes are affixed to the concrete with high-strength adhesive tape (figure 8).The probes were placed at semi-central locations on all roof surfaces (figure 9). In the case of the green roof, a location was chosen where the vegetation cover was an average representation of the whole roof. Thermocouple wires from each location were run into a watertight box on the black section of the roof that held the data logging equipment. (Stuart Baur, Investigating and Analyzing the Energy Performance of an Experimental Green Roof System Installed on an Institutional Facility 2013)



Figure 9: Thermocouples affixed to the concrete sub-slab beneath each roof section.

3.0 SIMULATION MODEL

After the collection of data from the green roofs in Burbank and Rolla, the next step is model the green roof on a building with the obtained data from the sensors. Building envelope and the components (HVAC systems) are the two most important factors of a building energy simulation model.

3.1. Simulation engine and graphic user interface

Energy simulation software have what is known as graphic user interface (GUI) and a simulation engine. The GUI is used to input files for simulations and also to display the simulation results. There can be multiple GUI for one simulation engine. For this research, 3D graphical design modeling software called Design builder, with EnergyPlus has its simulation engine is used.

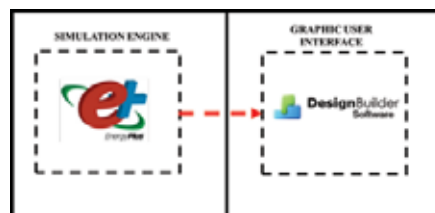

Figure 10: Energy simulation engine and the GUI.

3.2. Modeling a green roof in Design Builder with EnergyPlus engine

Lack of green roof design energy modeling tool, led Dr. David J. Sailor to develop a computational model of green roof which included heat transfer process in them. The green roof model designed by Sailor and his students at the University of Portland, was first used in Energy Plus v2.0. It was based on the FASST (**F**ast All-Season Soil Strength) vegetation models for the US Army Corps of Engineers developed by Frankenstein and Koenig.

In Energy Plus the user can specify the eco roof as the outer layer for the roof construction options. The user must also specify other parameters involving the green roof construction which includes parameters like soil moisture conditions (including irrigation), plant height, growing media depth, plant canopy density, thermal properties and stomatal conductance (ability to transpire moisture).

The green roof model takes into account the following:

- Conduction of heat in the different layers of the soil.
- Evapotranspiration from the plants and soil.
- Convective heat transfer due to the plant canopy.
- Radiative exchange within the plant canopy, due to long and short wave of the sun.

3.3. Limitations of modeling a green in Design Builder

For the Conduction Transfer Function (CTF) algorithm to work, we need to input specific parameters with respect to the soil and plants. The parameters have specific ranges for the data inputs beyond which, we cannot input the data. The ranges for the various parameter are shown in Table 1.

Table 1: Ranges of various parameters input for Ecoroof model (The Encyclopedic Reference to EnergyPlus Input and Output 2011).

Parameter	Data range	Typical values
Height of plants	0.005m - 1.0m	
Leaf Area Index (LAI)	0.001 - 3	
Leaf Reflectivity	0.05 - 0.5	0.18 - 0.25
Leaf Emissivity	0.8 - 1.0	
Minimum Stomatal Resistance	50s/m - 300s/m	
Thickness (of layer)	0.05m - 0.7m	0.15m - 0.3m
Conductivity of Dry Soil	0.2W/(m-K) - 1.3W/(m-K)	0.3W/(m-K) - 0.5W/(m-K)
Density of Dry Soil	300 kg/m ³ - 2000 kg/m ³	400 kg/m ³ - 1000 kg/m ³
Specific Heat of Dry Soil	>0.0 J/(kg-K)	
Thermal Absorptance	0.0 - 1.0	0.9 - 0.98
Solar Absorptance	0.0 - 1.0	0.6 - 0.85
Visible Absorptance	0.5 - 1.0	
Saturation Volumetric Moisture Content of the Soil Layer	0.1 - 0.5	
Residual Volumetric Moisture Content of the Soil Layer	0.01 - 0.1	
Initial Volumetric Moisture Content of the Soil Layer	0.05 - 0.5	

4.0 METHODOLOGY

The research methodology consists of various phases, each phase dependent on the other and followed in the order of green roof model Validation, Simulation and Analysis as shown in the flowchart below.

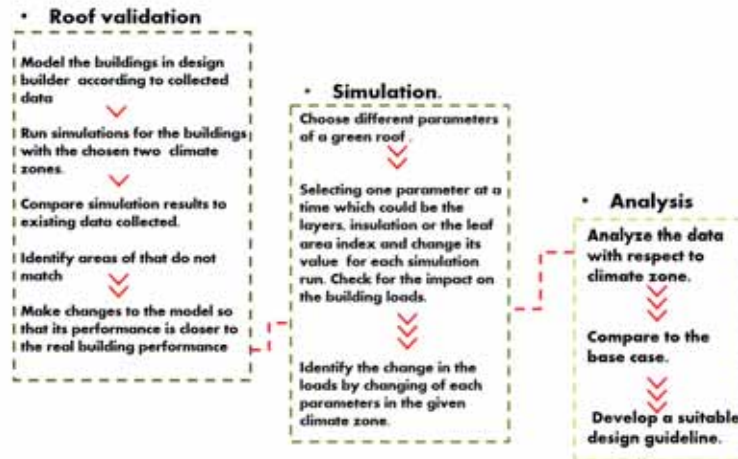

4.1. Green roof model validation

Since, the research focuses on green roof modeling, a DOE2 model of office building is considered. The roof of this building is modeled to be Eco-roof using the design builder software. The Eco roof is modeled accurately enough to match the real case scenario.

This is done by modeling the roof assemblies on the DOE2 model from the data obtained (as mentioned in chapter 3) from the buildings with green roof in both Burbank and Rolla. The simulations are run to determine the performance of the green roof with the respect to climate zones and construction type. The simulation results are then compared to the green roof data that was collected. Changes are made to the model until a benchmark of +/- 20% difference between the actual field data and simulated data is obtained.

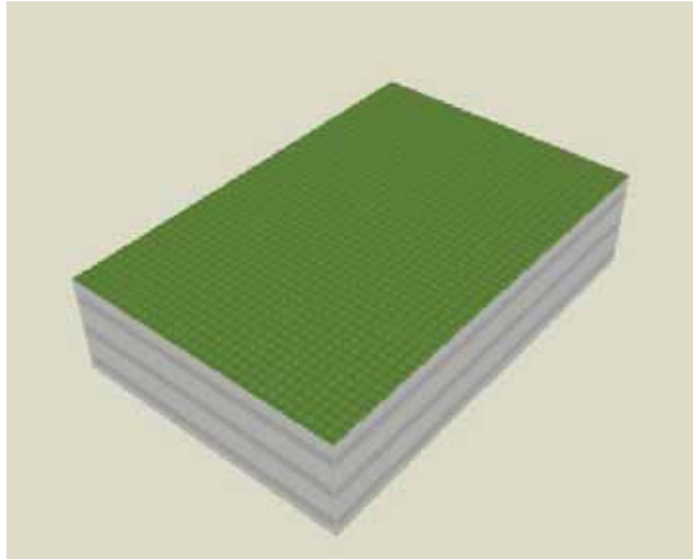

Figure 11: Green roof model for validation using Design Builder.

4.2. Simulation

Simulation phase is that phase in which, once the accuracy of the model against the field data is achieved the model is used for various parametric simulation study. The model is tested with various parameters in the chosen two climate zones. The main purpose of simulation running over various parameters is to study the impact of energy load of a green roof on the building with respect to the climate zones they are located in. Simulations also help us understand the thermal performance of the green roof with varying parameters involved the green roof.

There are various parameters on which the performance the green roof can depend on they are orientation, insulation, climate, height of the building , roof slope , soil depth , vegetation type , Irrigation, building function , drainage system , thickness of drainage system etc.



Figure 12: Various parameters that would be used in this research are shown in the section of green roof

In this research, four parameters that would be tested are Insulation, Soil Depth, Vegetation type and Climate type.

4.3. Parameter 1: Insulation

In any kind of a roof an insulation layer is optional, the same holds true even in the case of green roof. Green roof itself acts like an insulation, due to the soil layer and vegetation. Insulation boards in a green roof provide extra protection as they are placed under the water proofing member. The different subsets under the insulation that would be studied are:

- No Insulation.
- 4" Insulation.
- 6" Insulation.
- 8" Insulation.

4.4. Parameter 2: Soil depth

Soil depth in a green roof varies based on the type of the green roof being constructed. Based on the type of vegetation used for the green roof, they are classified into three categories of green roof with varying soil depth. They are Intensive, Extensive and Semi- Intensive green roof. For the construction of Intensive types of a green roof, the soil depth usually needs to be 12 inches or deeper. Green roofs with soil depth 2 inches to 6 inches, lie under the category of Extensive green roof type. Semi-Intensive green roof is one, where the soil depth lies between 6 inches to 12 inches.

The three sub parameters under soil depth that could be considered for this research are:

- 3" thick soil (extensive)
- 6" thick soil (semi-intensive)
- 12" thick soil (intensive)

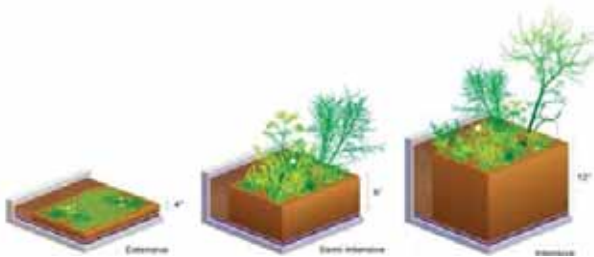

Figure 13: Different soil depths (Groundworks Sheffield)

4.5. Parameter 3: Vegetation type (based on the leaf area index)

Types of plants used on the green roof vary with geographical location. Not all plants can survive in varying climates of United States. Soil depth in the green roof, depends on the type of plants used. Plant type used on the green roof also has an effect on the thermal performance of the roof. Plants have different leaf area Index (LAI), LAI is defined as the amount of leaf area in a vegetation canopy per unit land area (Scurlock et al. 2001). LAI is one of the most important parameter in green roof, since it affects the heat flux between the plants and atmosphere. In other words, LAI provides solar shading on the roof surface.

The sub variables used are:

- LAI = 1
- LAI= 3
- LAI=5



Figure 14: Various LAI in plants.

4.6. Parameter 4: Climate type

Two climate zones are selected to study the thermal performance of the green roof with respect to various parameters. The climate zones chosen are:

- Climate zone 3 – Hot Dry – California – Burbank.
- Climate zone 4 – Humid – Missouri – Rolla.

CONCLUSION

On completion of all the simulation, the energy loads on the building are calculated and analyzed. The hypothesis which is - The impact of the efficiency of energy saving of a green roof depends on various composition parameters and the climate zone they are located in is tested. A part from that, the best combination of green roof parameters, with respect to the climate zone, to obtain a maximum thermal efficiency of the green roof is studied. Once this is completed, guidelines for designing the green roof to obtain the best thermal performance in the chosen two climate zones is developed, which could be possible by studying all the chart in details.

REFERENCES

- Corden, Yancey, 2011. Efficacy of green roof technology in colder climate. *Efficacy of green roof technology in colder climate*, 1, 8.
- Corden, Y. 2011. Efficacy of Green Roof Technology in Colder Climates. *Earth Common Journal*, 1(1).
- D'Orazio, M., Di Perna, C. and Di Giuseppe, E. 2012. Green roof yearly performance: A case study in a highly insulated building under temperate climate. *Energy and Buildings*, 55, pp.439–451.
- www.epa.gov, 2014. *Urban Heat Island Effect*. [Online] Available at: <http://www.epa.gov/heatisld/index.htm> [Accessed 24 May. 2014].
- Garrison, N. and Horowitz, C. (2012). *Looking Up: How Green Roofs and Cool Roofs Can Reduce Energy Use, Address Climate Change, and Protect Water Resources in Southern California*. California, pp.15-16.
- Kwok, Alison, and W. Grondzik. "Roddy/Bale Green Roof Study," Proceedings of 33rd National Passive Solar Conference—Solar 2008, San Diego, California, May 4–8, 2008.
- La Roche P. 2009 *Low Cost Green Roofs for Cooling: Experimental Series in a Hot and Dry Climate*. Passive Low Energy Conference, PLEA 2009, Quebec Canada.
- La Roche, Pablo, Eric Carbonnier, and Christina Halstead. "Smart Green Roofs: Cooling with variable insulation." PLEA2012 - 28th Conference on Passive and Low Energy Architecture, November 7-9. Lima, Peru: PLEA, 2012.
- Mukherjee, S., La Roche P., Konis K.,Choi, Joon Ho 2013. *A Parametric Study of the Thermal Performance of Green Roofs through Energy Modeling* (2012). ASES National Conference, Baltimore.
- Mukherjee, S., La Roche P., Konis K.,Choi, Joon Ho 2013. *Thermal Performance of Green Roofs: A Parametric Study through Energy Modeling in Different Climates*, Passive Low Energy Architecture Conference PLEA 2013, Munich 2013.
- Paul D. Wolfe, Katie Felver, 2010. "Blue and green: a study of urban greenroof performance at the Indigo and cyan buildings in Portland, Oregon, ASES Proceedings, Phoenix, AZ
- Paul D. Wolfe. 2011. "Pacific Northwestern Exposure: A Long-Term Study of Pacific Northwest Climate on Extensive Green Roof Performance in Portland, Oregon, Raleigh, NC
- Permanentroof.com, 2014. *We install many different types of Green and Eco-Friendly Roofing Systems | Permanent Roof - Serving Los Angeles Since 1924*. [Online] Available at: <http://permanentroof.com/green-roofs/> [Accessed 24 May. 2014].
- Rosenzweig, C., S. Gaffin, and L. Parshall, (Eds.) 2006. *Green Roofs in the New York Metropolitan Region; Research Report*. Columbia University Center for Climate Systems Research and NASA Goddard Institute for Space Studies. New York. 59 pages.
- Show Lin, B., Chung Yu, C., Tsen Su,, A. and Jou Lin, Y. 2013. Impact of climatic conditions on the thermal effectiveness of an extensive green roof q. *Building and Environment*, pp.1-3.
- Sun, T., Ni, G., Tang, L., Zhang, S. and Kong, G. 2012. Experimental study of the thermal performance of a green roof. *Journal of Tsinghua University Science and Technology*, 52(2), pp.160--163.

Energy performance and community resilience: A review of housing policy and programs

Lisa D. Iulo¹, Kaitlin O'Brien¹

¹Penn State Architecture, University Park, PA

ABSTRACT: Americans spend more than \$160 billion on heating, lighting and cooling their homes annually and these costs are increasing. Energy costs place a disproportionate burden on low- and moderate-income families. In the U.S. there is an enormous gap (nearly \$50 billion) between the cost of home energy for electricity, heating, and air conditioning and the amount that residents can reasonably afford to pay. This discrepancy leads cost-burdened families to make difficult, sometimes dangerous, choices on where to spend. Moreover, low- and moderate-income residents are more impacted by disaster events. Therefore it is important to recognize how expenses related to energy use in residential buildings can be reduced through effective policy and the role that integrated planning and design plays in realizing more resilient housing and communities.

The objective of this research is to understand how energy is considered in American housing policy in order to determine how successful programs and strategies contribute to improved energy performance in the development of affordable housing. Housing policy was analyzed and successful strategies and case study projects were identified to establish best practices. Outcomes show that energy considerations in housing policy largely follow other patterns of more energy-conscious environmental design. More interesting is that the community-based approach infused in U.S. housing policy by the influence of Catherine Bauer remains central to more energy-conscious housing. Conclusions indicate that today's housing design and development strategies must address the important contemporary issue of resiliency by providing viable community-oriented solutions for integrating energy efficiency and renewable energy into housing society's most vulnerable citizens.

KEYWORDS: Housing, Energy, Energy-efficiency, Resilient Communities

INTRODUCTION

There is a direct link between the production of energy for use in buildings, climate change, and the resiliency of residential environments that must be addressed through responsible policy, planning and design.

Over the past five decades, climate change has had a profound impact on weather patterns. Rising air temperatures allow the atmosphere to absorb more moisture and hold it for longer periods of time, which has resulted in a growing amount of severe weather events. In the Northeastern US this means a rising trend in heavy precipitation, hurricanes and storms of increasing intensity and duration, and a heightened risk of high magnitude flooding. As the percentage of Americans living in the 100-year floodplain continues to grow, riverfront communities become more and more vulnerable due to rising flood insurance costs and damaged or overworked infrastructure. Energy costs are also rising, placing a disproportionate burden on low- and moderate-income families. "Americans spend \$161 billion on heating, lighting and cooling their homes. According to the Energy Information Administration, over the past 5 years the cost of home heating has more than doubled in some parts of the country." (HUD 2006, 2). This burden is exacerbated by an older housing stock, the majority of which are located in the coldest and warmest climate zones in the US (HUD 1999), making them even more susceptible to climate change related disaster events. In the U.S. there is an enormous gap (48.8 billion dollars) between the cost of home energy for electricity, heating and air conditioning and the amount that residents can reasonably afford to pay (Fisher 2012). This discrepancy leads low and medium-income residents to make difficult, sometimes dangerous, choices in where to spend and in worse case scenarios inability to pay for home energy leads to homelessness (Davis 2012).

Fortunately, recent research and experience has shown that expenses related to energy use in housing can be greatly reduced through effective architectural planning, design, and detailing for little if any increase in the cost of construction over conventional building. However, the question remains as to how these successes have or can inform policy to assure enhanced performance of communities and residential environments. This paper explores this question by analyzing US housing policy from the development of the National Housing Act of 1934 through implementation of current HUD directives and programs to

determine how energy performance is considered in the development of affordable housing. Case study projects and successful strategies were identified to establish best practices in attaining more resilient and affordable communities.

1.0 ENERGY CONSIDERATIONS IN US HOUSING POLICY



Figure 1: “Houser” Catherine Bauer advocated for a contextual and community-centered approach to housing celebrating European housing examples that included public amenities, individual gardens and distributed energy. “Heliotropic” housing was oriented for light, ventilation and views. Image: Paris Plessis-Robinson Garden City (Source: *Modern Housing*. Boston, New York, Houghton Mifflin Co., 1934).

1.1. Housers, community development, and housing policy 1934-1950's

Historically natural ventilation and light was integral to housing design, a recognized necessity for health and hygiene. A contextual approach to housing is evident in the design of social housing of the 1920s showcased in the groundbreaking *Modern Housing* (Bauer 1934). “The more recent inspiration for public housing emerged from the modern idea of planning, in the broadest sense, drawn heavily from European experiments in Garden City and municipally owned housing developments” (von Hoffman 2012, 6). Garden City planning and related housing appealed to Bauer in their functional planning, orientation, and utilization of open space, for overcoming the “fundamental deficiencies in light, sun, [and] ventilation...” but also for contributing to community enhancement (Bauer 1934, 149) (Fig. 1). Given the role that Catherine Bauer played in informing U.S. housing policy in the mid-1930s throughout the 1950s (Oberlander 1999), it seems evident that energy/environmental awareness related to social responsibility was implicit in U.S. housing Policy in its inception. Indeed, beginning with the United States Housing Act of 1937 energy costs associated with housing was included in the definition of ‘affordability’, defining maximum housing expenses inclusive of “heat, light, water, and cooking fuel” (United States Housing Act of 1937,1).¹ However, these “carrying costs” associated with the long-term affordability of housing is not the primary focus of US housing policy. Against the desires of Catherine Bauer and other “Housers,” housing policy was linked to slum-clearance projects. “Ultimately, housing policy is subject to politics” (van Hoffman 2012,12). Following the great depression housing policy focused on job creation. The first major revisions to the U.S. housing policy came following World War II in response to the need for more housing and addressing urban areas blighted as a result of suburbanization (HUD Historical Background, National Housing Act of 1949). Although some new housing construction programs continued through the mid-1970s, 1950s marked the beginning of a gradual shift away from new construction. The Housing Act of 1954 amended the 1949 Act to provide funding for the rehabilitation and conservation of deteriorating areas (in addition to limited new construction and demolition). During the 1940s and especially in the early 1950s, code enforcement and rehabilitation became the preferred method of slum control. “The idea of code enforcement was by no means a new idea to housing reformers. It dated from the early twentieth century... although public housers endorsed the standards of inner-city homes that lacked plumbing and other modern necessities, they generally dismissed the idea that code enforcement even in combination with rehabilitation could solve the problems of blight and slums (von Hoffman 2008, 14). However, the influence of Catherine Bauer may be embedded in policy’s attempt at community “renewal”²; A summary of provisions of the National Housing Act of 1954, calls for rehabilitation or redevelopment programs “...for the establishment and preservation of a well-planned

community with well-organized residential neighborhoods and decent homes and suitable living environments for adequate family life” (National Housing Act of 1954, 22).

1.2. Energy in housing policy, programs and competitions from 1960 through 2000

“Legislation in the 1960s expressed the social concerns of providing decent and sanitary housing and ensuring that such housing is made available to all,” related to the Civil Rights Act of 1964 (HUD Historical Background, 1960s). For better or worse, the focus of US housing policy remained (remains) significantly on support for home ownership. The two decades from 1970-1990 saw the emergence of several new housing programs. A new community development Block Grant (CDBG) program, providing “flexible funding for community needs” was introduced in the 1974 Act and “remains one of the longest continuously running programs at HUD” (CDBG 2014). Policy during the decade also favoured “demand side” incentives (Mallach 2009, 18). Rental voucher programs were introduced beginning as early as the 1940s, but were widely condemned by public housers (von Hoffman 2008, 10). They found traction in the Community Development Act of 1974 with the introduction of the Section 8 Leased Housing Assistance Program.³

Not surprisingly US Housing Policy in the 1970s responded to national (and international) attention to energy. Language about the environment, natural resources and solar energy appears in the 1974 Act. A section entitled *Energy Conservation* was added to the 1937 Act during the 1970s and both passive and active solar energy was also directly addressed in US housing policy during that decade. “An authoritative non-profit, nongovernmental “National Institute of Building Science” [was authorized] to develop, promulgate and evaluate criteria for housing and building regulations” (CRS 1974, 69). Now celebrating its 40th year, this Institute continues to develop and disseminate building science information “for the purpose of improving the performance of our nation’s buildings while reducing waste and conserving energy and resources” (<http://www.nibs.org>). During the late 1980s and early 1990s legislation- including the Energy Performance Contracting introduced in 1987, the 1991 DOE Building Energy Codes Program (BECP), and Energy Policy Act of 1992/1992 Model Energy Code- resulted in the incremental improvement of the energy performance of affordable housing.

The Quality Housing and Work Responsibility Act of 1998 (QHWRA), signed into law in 1998 and constituting a substantial overhaul of the United States Housing Act of 1937, was created for the purpose of revitalizing severely distressed public housing projects (Greenbaum 1998, 310). QHWRA concentrated on “de-concentrating poverty and promoting mixed-income communities in public housing” (Gray 1999). In this act all provisions for energy conservation and solar energy were struck from housing policy (QHWRA 1999). The term “energy” was changed to “utility” in accordance with Section 564(1)(b) of the QHWRA amended section 6(j)(1)(d)), but *utility* consumption was one indicator that the HUD Secretary was authorized to use for evaluating the performance of public housing agencies and resident management corporations (QHWRA 1999, 39). Moreover, through the Urban Revitalization Demonstration (URD) program/HOPE VI, “concepts of ‘new urbanism’... closely aligned with the energy-savings concepts embedded in Smart Growth – “have been embraced by HUD as the appropriate approach to revitalization of public housing” (Greenbaum 1998, 332).

Throughout the last century American’s struggled to afford even “a median-priced home in the area where they lived” (Guttman 1993, 131). When HUD budgets were gutted in the 1980s and early ‘90s, not-for-profit development corporations stepped in to fill a detrimental gap in providing low-income solutions. A new era of “housers and other architects” came onto the scene (Gutman 1993), speculating on low-income housing solutions, mostly for urban infill conditions, through architectural competitions. Some competition briefs defined standards for design and project performance, including energy (*Progressive Architecture* 1992). Federal programs, including CDBG and Low Income Housing Tax Credit (LIHTC) and HOME programs introduced in 1986 and 1990 respectively, remain the primary funding source for providing affordable housing. These programs present interesting opportunities for influencing design related to building energy performance. Allocation plans for LIHTCs, administered at the state level, may include both Federal mandates for performance and state-determined criteria. For example, Pennsylvania’s LIHTC allocation plan requires Energy Star performance standards and provides incentives for Enterprise Green Communities and higher (Passive House) performance.

1.3. Recovery, reinvestment and housing resiliency

Pursuit to HUD’s long-term mission *To increase homeownership, support community development and increase access to affordable housing free from discrimination* HUD strategic plans since 2006 have linked sustainability to community primarily through Section 8, LIHTC, HOME and Community Development Block Grant programs (HUD Strategic Plan 2006-2011 and 2010-2015). In fact, in the 2010-2015 HUD Strategic Framework, HUDs mission was revised to *Create strong, sustainable, inclusive communities and quality, affordable homes for all*. The Energy Policy Act of 2005, building off the Energy Action Plan adopted in 2002 to promote energy efficiency in all HUD programs, contained several provisions that resulted in the improved energy performance in public housing, raising energy standards from the 1992 Model Energy Code to meet or exceed 2003 International Energy Conservation Code (HUD 2006). In FY 2007, Section 152 of the

Energy Policy Act of 2005 required (when cost-effective) the purchase of energy-efficient appliances and Energy-Star products (HUD 2006, 21). Most influential in recent years has been the American Recovery and Reinvestment Act of 2009 and related programs. Under the U.S. Department of Energy's (DOE) Weatherization Assistance Program (WAP) local weatherization agencies provide energy conservation services to low-income housing including air sealing, storm windows, replacement windows, attic insulation, water efficient showerheads and faucet aerators, and tune-up of heating equipment. In addition to the Weatherization Assistance Program, the DOE Better Buildings Initiative, instated through investments associated with the Recovery and Reinvestment Act, was introduced in 2011 to reduce energy consumption in commercial and industrial buildings; in 2013, as part of the 2013 climate Action Plan, the DOE and HUD partnered to expand the Better Buildings Challenge to the multifamily residential sector. In addition to strategies to reduce energy demand in affordable housing, President Obama's Climate Action plan includes a goal to produce 100 MW of renewable energy capacity on-site at federally supported housing by 2020 (Solar Progress Report 2014). CDBG Disaster Recovery (CDBG-DR) funds allocated from the Disaster Relief Appropriations Act of 2013 are resulting in precedent-setting designs for responsible, community-oriented, energy-conscious affordable housing development.

2.0 AFFORDABLE HOUSING AND RESILIENCE COMPETITIONS

Between 2011 and 2013 forty-eight states, along with Washington D.C., had disasters declared due to extreme weather events, which according to the National Climate Assessment are going to be occurring more and more frequently due to climate change. HUDs most recent NOFA (notification of funding availability) for the National Disaster Resilience Competition invites eligible communities to compete for nearly \$1 billion CDBG-DR funding. In the wake of past natural disasters, this competition is focused on solving the unmet needs of past disasters as well as enhancing communities' ability to mitigate and adapt to future chronic or acute stressors to address the environmental and economic resilience of communities. In partnership with the Rockefeller Foundation, The National Disaster Resilience Competition builds off previous CDBG-DR efforts including the "Rebuild By Design" competition of 2013.

2.1. Rebuild by design

Rebuild by Design was a competition created by HUD, the Presidential Hurricane Sandy Rebuilding Task Force, and the Rockefeller Foundation in order to assess the preparedness of disaster affected regions, and design innovative solutions to the vulnerabilities communities face as an effect of global climate change. The competition focused on areas devastated by Hurricane Sandy with proposals for coastal communities, particularly in Northern New Jersey and New York City.



Figure 2: Submissions to the 2013 "Rebuild by Design" competition explored critical infrastructure solutions including food security and community-scale distributed energy. Above: overview site plan of Hunts Point Proposal, Source: (courtesy of Rebuild by Design/PennDesign/Olin).

A main goal of this competition was hazard mitigation, including critical infrastructure and resource protection. Rebuild by Design identified five main components necessary for the resilience of all systems:

- Diversity of resources in order to allow for a wide range of responses;
- Redundancy, or having back-up systems;

- Connectivity to provide rapid detection of changes;
- Modularity to allow individual units to retain self-sufficiency if disconnected, and;
- Adaptability, the capability to modify responses to stressors.

HUD allocated 930 million dollars to this project, which was divided between the winning proposals in order for the teams to begin implementation.

One of the winning proposals by PennDesign and OLIN focused on Hunts Point, an extremely poor South Bronx neighborhood that is a food supply hub serving over 20 million people (fig. 2). An important focus of this project is energy resilience, in order to assure continued power to the food distribution center as well as provide affordable energy to the workers, tenants and homeowners that live in the area. Power loss in Hunts Point results in millions of dollars in spoiled food, critically affecting the economy in an already low-income area. A long-term energy resilience goal is to create a micro-grid in order to allow the peninsula to operate independently should the main power grid fail. Along with this, tri-generation energy is proposed, a system that captures and utilizes the waste heat from fossil fuel electricity generation. Using tri-generation would decrease the cost of energy so substantially that the electricity subsidy currently available for residents of Hunts Point could be completely eliminated, while still allowing for a reduction in overall energy costs (fig. 3).

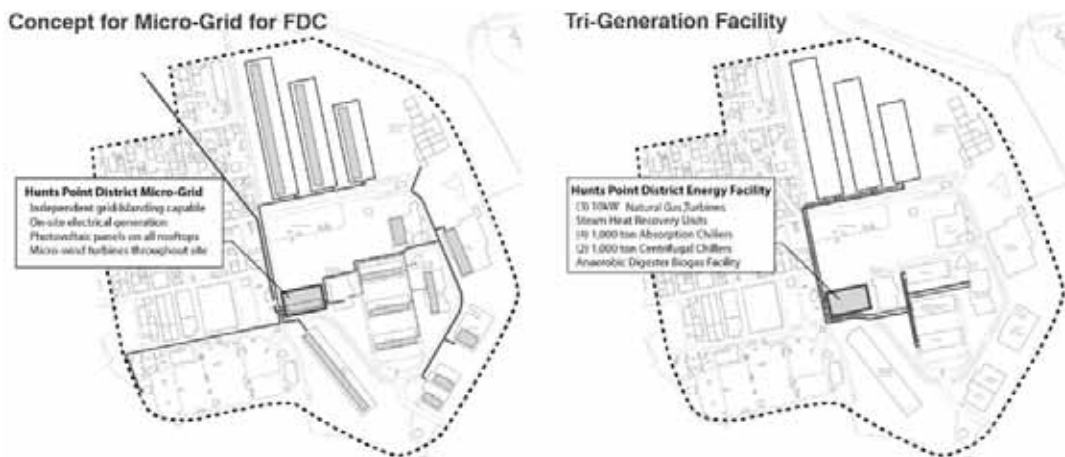

Figure 3: The “Rebuild by Design” proposal for Hunts Point included a community scale micro-grid and tri-generation energy facility. Source: (courtesy of Rebuild by Design/PennDesign/Olin).

2.2. Scaled solutions to housing development and community resilience

A resilient community is tough and has effective defenses along with the ability to fight against hazards and disasters, but these admirable attributes are not the only qualities resilience is centered on. A resilient community is conscientiously focused on the ability to bounce back with minimal effort and waste, while consistently investigating, testing, and implementing smarter ways to adapt. The Rockefeller Center defines resilience as the “capacity of individuals, communities, institutions, businesses, and systems... to survive, adapt and grow, no matter what chronic stresses and acute shocks they experience” (100 Resilient Cities). To achieve this, a multi-scaled approach to housing and community development is necessary.

Three inter-related scales are evident in the policy and programs studied above and must be considered and integrated through holistic design. These are:

- Community-based solutions for resilient, energy-conscious community design thinking:
As increasing numbers of Americans move back into cities, urban densification through infill construction, brownfield site reuse and building renovation or repurposing is necessary. This “Smart Growth” development must happen in a way that enhances ecological and energy infrastructure and reinforces community interaction. By considering the interconnection between buildings, co-generation and “tri-generation” becomes feasible, providing potential for reliable energy and “sheltering in place”. Finally, the “energy-water-food nexus” should be considered (Brownson 2014). Allotment gardens were featured prominently in the projects featured in *Modern Housing* (Bauer 1934) and urban food production, community gardens and aquaponic architecture are currently popular. The “Hunt’s Point Lifelines” project illustrates the important connection



Figure 4: The Hunt's Point "Rebuild by Design" scheme by PennDesign/Olin proposes a new 6-day farmers market to create jobs, increase food security, and improve over-all community well-being. Source: (courtesy of Rebuild by Design/PennDesign/Olin).

- Building-scale solutions that consider form and construction methods and materials: Housing design and renovation must go beyond the insulation and envelope improvements considered in weatherization programs to address building location and orientation. Materials must be highly energy efficient, durable and replaceable or "permeable" (fig. 5; Henrique 2014).

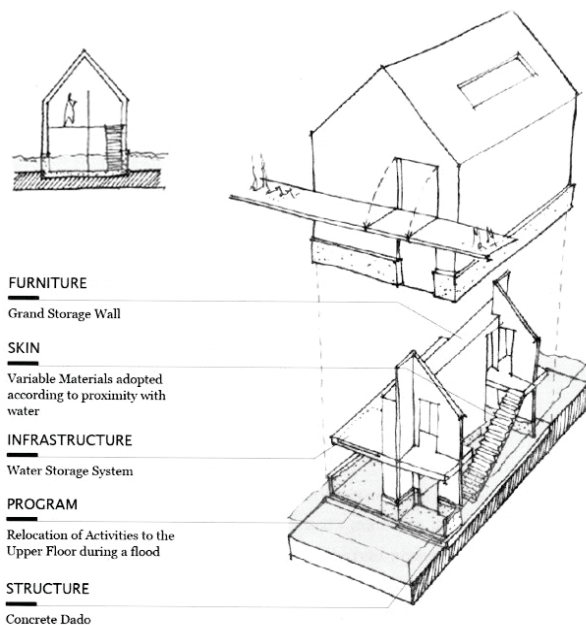

Figure 5: Karen Henrique illustrates permeable, flood-resilient design techniques. Source: (M.Arch thesis, Penn State, 2014).

- "Smart" controllable and integrated building systems
Foremost, active building systems (and community infrastructure) must be out of harm's way in the face of disaster, and easily accessible and replaceable. "Smart" systems are coming to the fore in energy and building research; Ideally these systems should be controllable, interconnected and integrated (fig. 6). Unlike at the building scale where optimizing materials and methods is preferable, redundancy in building systems is beneficial.

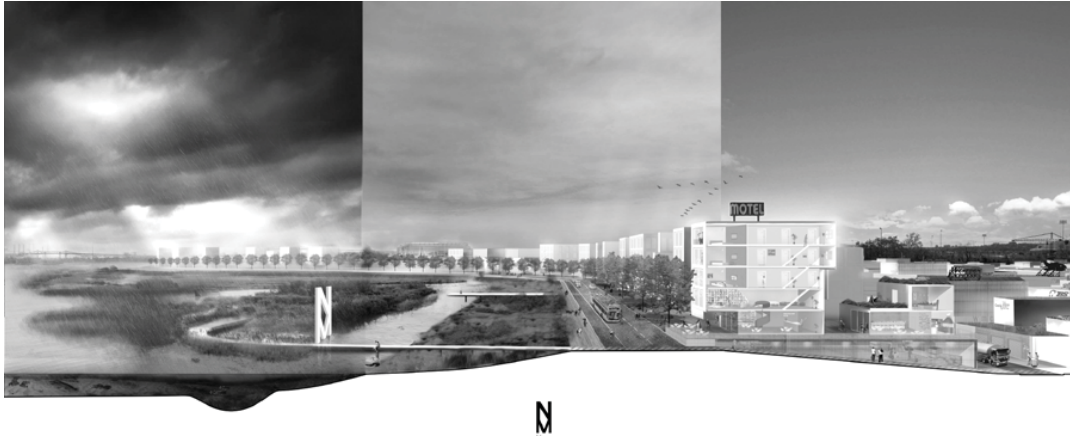

Figure 3: The Rebuild by Design “New Meadowlands: Productive City + Regional Park” proposal envisions integrative ecological, energy, data and waste management infrastructure at multiple scales. Source: (courtesy of Rebuild by Design / MIT CAU/ZUS/ Urbanisten).

CONCLUSION

Much of the existing affordable housing is in disaster-prone areas, and future housing development is likely to occur in increasing density along coastal areas and in floodplains.⁴ Therefore holistic planning at multiple scales is necessary to responsibly retrofit or develop affordable housing in the US. The innovative “Rebuild by Design” projects provide some guidance. However, the competition teams faced multiple obstacles stemming from existing policy and regulatory framework, revealing that many governmental policies are not set up to fully allow resilience in our built environment. As the implementation stage continues, unless policy changes can be realized, many teams will be forced to adjust their responses and communities will suffer in the face of climate-related disaster.

Housing Policy and programs are beginning to address energy-responsible, more sustainable and resilient housing and communities through measures at the community, building envelope (insulation and weatherization) and systems scale (more efficient appliances and equipment). However, for the most part, they have limited impact. Recent presidential and legislative action has directed HUD to implement energy-efficient and green building practices and provides for greater cooperation between DOE, EPA and HUD in the interest of improving energy performance and oversight in public housing (Energy Task Force 2008 & Power 2006). Conditions for capital funding that encourage improvements in energy performance of new housing may hold potential for reducing energy use and associated energy costs. Retrofit programs also contribute to the national effort towards energy efficiency (Sullivan 2012). However, housing subsidies and funding opportunities are very limited. Moreover, “the U.S. stock of publicly-owned housing is negligible; nearly all low-income Americans live in private housing, and only a small minority, between 7% and 15% enjoy any form of rent subsidy” (Power 2006). Furthermore questions are being raised about whether households are equally able to participate and benefit from energy-efficient housing programs and policies (Braubach and Ferrand 2013). Codes may hold potential for greater impact. Energy policy has led to steady improvement in the International Energy Conservation Code (IECC) recommended energy performance standards since 2006. These improvements have also been reflected in the DOE ENERGY STAR certification program. However IECC recommendations are not uniformly adopted by all jurisdictions and ENERGY STAR is a voluntary program. Looking beyond the building the question of energy becomes even more difficult. The energy distribution system in the US lacks a structured means for policy regulation (Powers 2006). Furthermore, the legal status of community-scale distribution of energy through micro-grid deployment is hindered by the lack of a nationally uniform definition (Lulo et al 2011). It is evident that policy is necessary and programs need the teeth of mandates that come down from a federal level. However some have warned against broad-brush national approaches since the climatic considerations of each state must be considered. Therefore the best path forward may be a push for stronger state regulations with federal oversight of minimal energy performance benchmarks (U.S. Senate 2014). Regardless a top-down approach needs to be fueled by inclusive initiative. Designers must maintain the foresight to consider equitable, holistic and inter-related multi-scaled energy solutions in the design of our built environment.

ACKNOWLEDGEMENTS

The authors gratefully acknowledge the generous support of the Penn State Institute for the Arts & Humanities (IAH), Hamer Center for Community Design Assistance, and the Penn State Institutes of Energy and the Environment (PSIEE).

REFERENCES

- 100 Resilient Cities, <http://www.100resilientcities.org/resilience> accessed 10/22/2014.
- Bauer, C., 1934, *Modern Housing* (Boston and New York: Houghton Mifflintown Company).
- Braubach, M. and Ferrand, A., 2013, "Energy Efficiency, housing, equity and health," *Int J Public Health* 58:331-332. DOI 10.1007/s00038-012-0441-2
- Jeffrey Brownson (unpublished manuscript, Penn State, 2014).
- CDBG, Community Block Grant Program, HUD.GOV.
http://portal.hud.gov/hudportal/HUD?src=/program_offices/comm_planning/communitydevelopment/programs (accessed 2 December 2014).
- CRS (Congressional Research Service), "The Housing and Community Development Act of 1974 (Public Law 93-383: Summary and Analysis," Morton J. Schussheim, Frank R. Parente, Warren E. Farb, Barry P. Berlin, Jan w. Katz, Richard L. Wellons (Congressional Research Service Economic Division: Library of Congress, September 16, 1974).
- Davis, F., "Save Energy, Save Money, Fight Homelessness," HUDdle, March 27, 2012.
- Denzer, A., 2013, *The Solar House*, (New York, NY: Rizzoli).
- EIA (U.S. Energy Information Administration) "Residential Energy Consumption Survey (RECS)."
<http://www.eia.gov/consumption/residential/>
- Energy Task Force, 2008, "Implementing HUD's Energy Strategy," submitted pursuant to Section 154 Energy Policy Act of 2005, December 2008.
- Fisher Sheehan Colton, 2012, "On the Brink: 2011 - The home energy affordability gap, Pennsylvania' *Public Finance and General Economics*, Belmont, MA.
- Gray, T. A.C., 1999, "De-Concentrating Poverty and Promoting Mixed-Income Communities in Public Housing: The Quality Housing and Work Responsibility Act of 1998." *Stan. L. & Pol'y Rev.* Volume 11:1, 1999.
- Gutman, M., "Housers and Other Architects: Pragmatism and Aesthetics in Recent Competitions." *Journal of Architectural Education* 46, No. 3 (Feb.1993): 131-146. Stable URL: <http://www.jstor.org/stable/1425156> (accessed 07 August 2014).
- Karen Paiva Henrique, "Transition As Condition" Toward Flood Resilience Through Flexible Architecture" (M.Arch thesis, Penn State, 2014).
- HUD, 1999, U.S. Department of Housing and Urban Development, Energy Expenditures in Public Housing, Report to the Senate Committee on Appropriations, June 1999.
- HUD, 2006, "Promoting Energy Efficiency at HUD in a Time of Change Report to Congress," Submitted under Section 154 Energy Policy Act of 2005 (Washington, DC: Office of Policy Development and Research, August 8, 2006).
- "HUD Strategic Plan FY 2006- FY 2011," U.S. Department of Housing and Urban Development, March 31, 2006. http://www.hud.gov/offices/cfo/reports/hud_strat_plan_2006-2011.pdf (accessed 28 November 2014).
- HUD FY 2010-2015 Strategic Plan, Executive Summary.
http://portal.hud.gov/hudportal/documents/huddoc?id=DOC_4437.pdf (accessed 28 November 2014).
- HUD Historical Background, The 1930s.
<http://www.hud.gov/offices/adm/about/admguides/history.cfm> (Accessed 25 November 2014).
- Iulo, L.D., Haskar, R., Blumsack, S., 2011, "Design Strategies for Community-Scale Renewable Energy Solutions," *Architecture and Sustainable Development*, Vol. 1: 27th Conference on Passive and Low Energy Architecture, Magali Bodart and Arnaud Evrard (eds.). UCL Presses: 621-626.
- Mallach, A., 2009, *A Decent Home: Planning, Building, and Preserving Affordable Housing*, Chicago: APA Press.
- National Housing Act of 1949, "Housing Act of 1949, Summary of Provisions of the National Housing Act of 1949," 81st Congress 1st (Washington, D.C.: Committee on Banking and Currency, United States Senate).
- National Housing Act of 1954, "Summary of Provisions of the National Housing Act of 1954," report by the Committee on Banking and Currency, United States Senate, presented by Mr. Knowland, February 15, 1954 (Washington: Government Printing Office).
- Oberlander, H.P. and Newbrun, E., 1999, *Houser: The Life and Work of Catherine Bauer* (British Columbia: UBC Press).
- Power, M., 2006, "Fuel poverty in the USA: The overview and the outlook," *Energy Outlook*, Issue No. 98, March 2006. <http://www.opportunitystudies.org/repository/File/fuel%20poverty.pdf> (accessed 05 February 2015).
- Progressive Architecture Magazine*, "P/A Affordable Housing Initiative", August, 1992
- QHWRA 1999, "United States Housing Act of 1937 as Amended by the Quality Housing and Work Responsibility Act of 1998 as of 3/2/1999," Report to Congress.
- Rebuild by Design, <http://www.rebuildbydesign.org> (accessed 05 February 2015).
- Solar Progress Report- Advancing Toward a Clean Energy Future, the White House, May 2014; pg. 6-7

- Sullivan, Brian, 2012, "HUD Awards \$23 Million to Test New Energy-Saving Approaches in Older Multi-Family Housing Developments," HUD No. 12-051, March 8, 2012.
http://portal.hud.gov/hudportal/HUD?src=/press/press_releases_media_advisories/2012/HUDNo.12-051 (accessed 05 February 2015).
- United States Housing Act of 1937 [As Ammended] And Provisions of Other Laws and Executive Documents Pertaining to the United States Housing Authority* Definitions, Section 2 (1), September 1939, (Washington, D.C.: Federal Works Agency, United States Housing Authority).
- U.S. Senate, 2014, U.S. Sens. Lisa Murkowski (R-Alaska) and Tim Scott (R-S.C.) "Plenty at Stake: Indicators of American Energy Insecurity," An Energy 20/20 White Paper, U.S. Senate September 18, 2014. http://www.energy.senate.gov/public/index.cfm/files/serve?File_id=075f393e-3789-4ffe-ab76-025976ef4954 (accessed 05 February 2014).
- von Hoffman, A., 2008, "Enter the Housing Industry, Stage Right: A Working Paper on the History of Housing Policy," February 2008 W08-1 (Harvard University: Joint Center for Housing Studies).
- von Hoffman, A., 2012, "A Rambling Edifice: Housing Policy in the Twentieth Century," December 2012, W12-9 (Harvard University: Joint Center for Housing Studies).

ENDNOTES

¹ The 1937 Act set the standard for affordability at one fifth of a household's net income (including the value of the cost of heat, light, water and cooking fuel). Today affordable housing expenses, including utilities, is set at not more than 30% of income; housing expenses exceeding 30% are considered a "cost burden" resulting in the potential for diminished quality of life.

² In the National Housing Act of 1954 the term "urban renewal plan" was substituted for "redevelopment plan" and defined more broadly to indicate the scope of urban renewal projects.

³ Initially the Section 8 program supported both leased and new housing development but the Section 8 new construction program was eliminated with the severe budget constraints that started in the 1980s. Housing Choice Vouchers remain the number one federal subsidy program for providing affordable housing.

³ For example see: Jesse M. Keenan and Vishaan Chakrabarti, 2013, *NYC 2040: Housing the Next One Million New Yorkers* (New York: CURE).

Is naturalness of elementary school sites linked to student's academic performance?

Muntazar Monsur¹, Ozlem Demir¹

¹NC State University, Raleigh, NC

ABSTRACT: A growing body of research has linked the environmental qualities of a school to students' academic performance. Previous studies showed that air quality around school buildings influences standardized test scores and attendance rates of students. One particular study revealed that views with greater quantities of trees and shrubs from classroom windows are positively associated with standardized test scores and graduation rates in high school students. In many other contemporary studies, increased contact with nature was found to be positively correlated with better performances of children. However, very few studies have investigated how the overall naturalness of a school building site may relate to its elementary school students' performance. Studies investigating such relationships with younger children in elementary schools are even rarer. Aim of this study is to address this gap in research and investigate empirically whether overall naturalness of elementary school environment links to children's academic performance.

This study investigates the potentials of available online resources to build a research strategy that can investigate the relationship between school surrounding *naturalness* and children's academic performance. A pilot data consisted of 20 randomly selected elementary schools located in Raleigh, North Carolina is used to demonstrate the proposed methodology.

KEYWORDS: School Building, Naturalness of School Sites, Academic Performance, I-Tree

INTRODUCTION

Although the underlying pathways of the effects of green spaces on health are not fully understood, a number of benefits including improved conditions of physical and mental wellbeing are linked to greenness/naturalness of surrounding environment. These benefits from exposure to green spaces can be expected to translate into a supportive environment for academic achievement in children as well. However, studies investigating the specific effects of school-site *naturalness* on students' academic performance are rare. When it comes to matters of elementary or preschool children, it is difficult to find a single study which has investigated this phenomenon. The objective of this study is to propose a methodological pathway to investigate this under-researched phenomenon of the influences of school-site naturalness on elementary school children's academic performance.

1.0 LITERATURE REVIEW

Child advocacy expert Richard Louv, in his influential work about the divide between children and the nature, discussed the lack of nature in the lives of today's wired generation. He calls it "nature deficit disorder"—and he points to it as a cause of some of the most disturbing childhood trends, such as the rises in obesity, attention disorders, and depression (Louv 2008). Having visual access to nature is known to be beneficial across a wide range of contexts. Two studies have given evidence (Taylor 2002, Wells 2000) that views of nature contribute to self-discipline of adolescent girls and cognitive functioning of children. The first study investigated the role of near-home nature on three forms of self-discipline among children (Taylor 2002). The aim to the research was to provide empirical evidence of the power of nature for *attention restoration*. The sample of the study was composed of 169 inner-city children randomly assigned to 12 architecturally identical high-rise buildings with varying levels of nearby nature. The results showed that the more natural a girl's view from home was, the better her performance scored in the tests of self-discipline. The second study (Wells 2000) showed that children who relocated to homes that improved the most in terms of surrounding naturalness tended to have the highest levels of cognitive functioning. The study had a small sample size (N = 17) and the author admitted that since the study was longitudinal (same group of children), the role of naturalness/greenness on cognitive functioning might have been temporary.

View of nature or surrounding naturalness is found to be associated with adults' physical and mental wellbeing. Kaplan (1993) reported two separate studies on the presence versus absence of natural window views. In the first case, workers with natural views reported fewer common health ailments in the preceding six-month period and higher job satisfaction. In the second study, natural views were related to increased feelings of privacy and satisfaction; natural views were also associated with lower frustration and increased patience and task enthusiasm. In a similar line of research, having a view of forested settings was related to greater job satisfaction and lower stress in a South Korean sample (Sop Shin 2007). Research in the area of healthcare and physical well-being has shown that window views can influence health outcomes (Devlin and

Arneill 2003). Seminal work by Ulrich (1984) showed that patients recovering from gall bladder surgery who had views of trees recovered from surgery significantly faster, had fewer negative interactions with nursing staff, and used fewer analgesic medications when compared with those recovering in rooms with a less scenic brick wall window view. It was also shown that nature views promoted residential satisfaction and overall resident well-being (Kaplan 2001). Most of these studies were conducted in different work environments such as office spaces, residences or hospitals; but findings indicate that similar positive effects of greenness/naturalness are also likely to motivate children’s performances classroom environments. However, research studies linking surrounding naturalness of school sites and children’s academic performances are rare.

Few studies were found which investigated the role of surrounding *naturalness* or *greenness* on the academic performance of students. One recent study (Benfield et al. 2013) examined differences across multiple sections of a college writing course in two types of identically designed classrooms—those with a view of a natural setting and those with a view of a concrete retaining wall (Figure 1). Results showed that students in the natural view classrooms were generally more positive rating the course. Students in the natural view condition also had higher end of semester grades. This particular study provided methodological insight and it is among few studies which adopted natural experimental design.

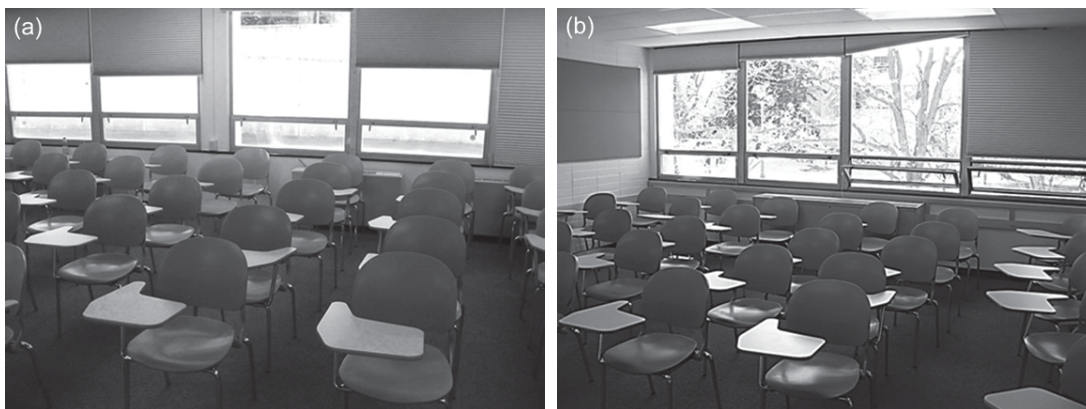

Figure 1: Natural view classrooms had higher end of semester grade (Source: Befield et. al 2013).

Another study showed that in high school students, views with greater quantities of trees and shrubs from classroom windows were associated with positive academic performance outcomes (Matsuoka 2010). This study revealed interesting findings regarding the greenness/naturalness of environment. Greener view and surrounding greenness of campus were found to be positively associated with standardized test scores, graduation rates, percentages of students planning to attend a four-year college, and fewer occurrences of criminal behavior. In addition, large expanses of landscape lacking natural features were found to be negatively related to these same test scores and college plans. On the other hand, the study by Tanner (2009) reported that when a student needed to take a break from learning, it was easier to get back on track after taking a quick look outside at a pleasant view than after doodling on paper. Tanner (2009) also qualified these views and indicated that not all views were beneficial. He differentiated those views indicating that while a view of a wall or parking lot was not desirable, *unrestricted views of nature, wild-life and human activity areas* may provide students and teachers with the much needed *quicker* mental break.

Table 1: Summary of findings of literature review

Finding	Source	Scope
Near home nature contributes to self-discipline and cognitive functioning of children	Taylor, 2002; Wells, 2000	Similar studies are needed for school environment
Classroom windows were positively associated with standardized test scores and graduation rates in high school students and test scores in college students	Matsuoka, 2010, Benfield et. al, 2013	Similar studies are needed for elementary school children
Natural view contributes to health and wellbeing of adults	Devlin and Arneill 2003, Kaplan, 2001, Sop Shin 2007, Ulrich, 1984; Walch et al., 2005,	Similar investigation is needed for health and wellbeing of children

The most important study on the similar topic has only recently been published. This study investigated the association between the “greenness” of the area surrounding a Massachusetts public elementary school and the academic achievement of the schools’ student body based on standardized tests with an ecological setting (Wu et al. 2014). Researchers used the composite school-based performance scores generated by the Massachusetts Comprehensive Assessment System (MCAS) to measure the percentage of 3rd-grade students. Surrounding greenness of each school was measured using satellite images converted into the Normalized Difference Vegetation Index (NDVI) in March, July and October of each year according to a 250-meter, 500-meter, 1,000-meter, and 2000-meter circular buffer around each school. Spatial Generalized Linear Mixed Models (GLMMs) estimated the impacts of surrounding greenness on school-based performance. Overall, the study results supported a relationship between the *greenness* of the school area and the school-wide academic performance. While Normalized Difference Vegetation Index (NDVI) is a useful tool, it could not be differentiated between different *greenness* of surfaces like grassy areas, urban forests or large/small tree covers, etc. Although, the current research also uses online resources for collecting data, it adopts a very different technique for data collection of school-surrounding vegetation data which has more precision in differentiating among different *green* surfaces and has more statistical accuracy.

2.0 METHODOLOGY

The pilot data collected for this project used mainly 2 web-based sources. All dependent variable data related to children’s academic performance was collected from a website called NC School report Cards (<http://www.ncreportcards.org/src/>). This web source was used also for many different other control variable data. Naturalness of a school site is measured by an online urban forest analysis tool called the i-Tree (www.itreetools.org). The i-Tree is a state-of-the-art, peer-reviewed software suite from the USDA Forest Service that provides urban forestry analysis and benefits assessment tools. Data was collected from randomly selected 20 elementary schools located in Raleigh, North Carolina. IBM SPSS software was used to conduct a multiple linear regression analysis on collected data of dependent variables (academic outcomes), independent variable (school-site naturalness) and control variables.

2.1. Data on academic performance

From NC School report Cards (<http://www.ncreportcards.org/src/>), the overall math percentage scores were collected for the 20 selected schools. This data was treated as the outcome variable (academic performance of students) in this pilot research project.

2.2. Data on school-site naturalness

The i-Tree software interface allowed the researchers to quantify the school-surrounding environment in different criteria. The system allowed entering specific land-cover types at the beginning of data collection and then based on the land-cover type entered for randomly selected data points of the selected site area, i-Tree can give an estimated percentage measurement for those different land-covers. The biggest advantage of using i-Tree instead of the NDVI technique used in the Wu et al. study (2014) is that, instead of just measuring the *greenness* parameter, it allowed the researcher to differentiate between different *natural* land-cover types such as grassy surface, urban forest, water surface, large or small tree areas etc. The statistical accuracy of i-Tree depends on the number of random points entered for a given area. For demonstration purposes, only two land-cover classes were created for this project namely *tree* and *non-tree*. As more random points are entered into the system classifying different land covers, the statistical accuracy also increases. For this pilot project a 500 feet buffer area from the school building was considered as the *school-surrounding* site. It is usually recommended to enter at least 500 random data points for a selected site. However, the purpose of this pilot survey was focused in demonstrating the methodology rather than providing empirical findings. Therefore, 100 data points were randomly entered for each of the 20 school’s site buffer area.

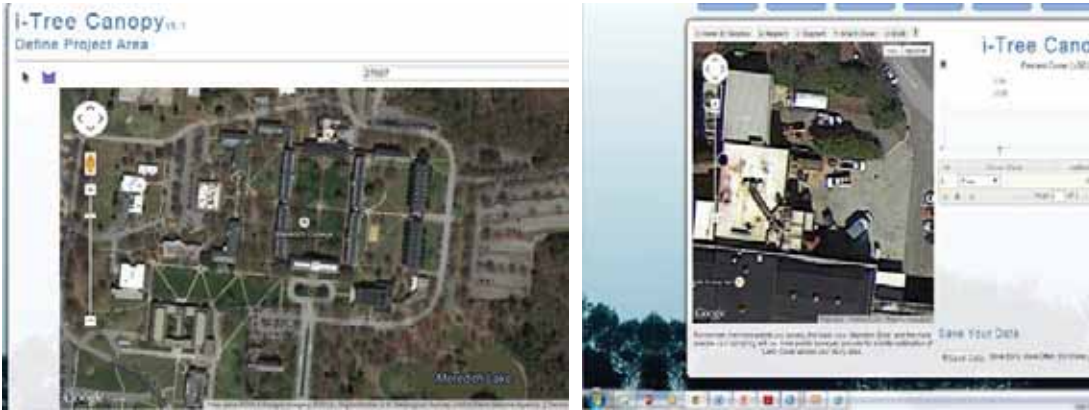

Figure 2: i-Tree interface.

Figure 2 shows screenshots of the i-Tree software interface for entering random data points for a selected site.

2.3. Data on school-site naturalness

Data on several controlling variables were also collected from NC School Report Cards (<http://www.ncreportcards.org/src/>) for the 20 selected schools. The controlling factors included crime per 100 students, school attendance, number of books per student, number of students per digital device, number of teachers, teachers percentage with advanced degree, number of board certified teachers, teacher experience, and total number of tests taken.

3.0 RESULTS

A multiple regression analysis using the *forward* technique in the IBM-SPSS software was employed. No statistically significant association was found between tree land cover (%) and elementary school students overall math score percentage. In the regression model, the only statistically significant predictor was *number of student per digital device* (at $p < .05$ level). The association predicts that when there are more students using a single digital device, it is likely that their overall math score would improve. However, the data presented in the analysis consists only a small sample of 20 schools, and the associated statistical power is very low. The purpose of this analysis is a demonstration of the methodology rather than establishing statistical relationships.

Table 2: Multiple regression analysis.

Excluded Variables ^a						
Model		Beta In	t	Sig.	Partial Correlation	Collinearity Statistics Tolerance
1	school_size	.041 ^b	.182	.857	.044	.863
	crime_per_100_student	.130 ^b	.615	.547	.147	.962
	school_attendance1	.192 ^b	.937	.362	.222	.996
	number_of_books_per_student1	.040 ^b	.162	.873	.039	.709
	number_of_teacher1	-.238 ^b	-1.145	.268	-.268	.950
	teacher_percentage_with_advanced_degree1	.132 ^b	.613	.548	.147	.927
	board_certified_teacher1	.131 ^b	.555	.586	.133	.777
	teacher_experience_0_3	.029 ^b	.133	.896	.032	.940
	teacher_experience_4_10	-.153 ^b	-.739	.470	-.177	.998
	teacher_experience_10_over	.077 ^b	.355	.727	.086	.926
	number_of_test_taken	.050 ^b	.227	.823	.055	.921
	Tree land cover percentage	-.056 ^b	-.260	.798	-.063	.944

- a. Dependent Variable: overall_math_percentage
- b. Predictors in the Model: (Constant), number_of_student_per_digital_device1

CONCLUSION

The aim of this exploratory study is opening a new line of investigation in the field of architecture-human behavior research. The methodology demonstrated in this paper with the small sample of 20 schools has a lot of potentials for investigating the *unknown* associations between school-site characteristics and students performances. It provides an alternative technique for assessing the naturalness of a site area which can be used to validate the results found in previous the previous study (Wu et al. 2014) which used NDVI technique. There are approximately 135,000 public schools in the United States containing more than 53 million of its young citizens. Large scale studies investigating the value of naturalness of school sites may contribute heavily to the design guidelines and design standards of school architecture to improve health and performance of young children. It is expected that findings from this pilot study will be valuable for establishing base findings regarding the argument and provide opportunities for large-scale studies in the related field of research.

REFERENCES

- Benfield, J. a, G. N. Rainbolt, P. a Bell, and G. H. Donovan. 2013. "Classrooms with nature views: Evidence of differing student perceptions and behaviors." *Environment and Behavior*. doi: 10.1177/0013916513499583.
- Devlin, Ann Sloan, and Allison B Arneill. 2003. "Health care environments and patient outcomes a review of the literature." *Environment and behavior* 35 (5):665-694.
- Kaplan, Rachel. 1993. "The role of nature in the context of the workplace." *Landscape and urban planning* 26 (1):193-201.
- Kaplan, Rachel. 2001. "The nature of the view from home psychological benefits." *Environment and Behavior* 33 (4):507-542.
- Louv, Richard. 2008. *Last child in the woods: Saving our children from nature-deficit disorder*. Algonquin Books.
- Matsuoka, Rodney H. 2010. "Student performance and high school landscapes: Examining the links." *Landscape and Urban Planning* 97 (4):273-282. doi: 10.1016/j.landurbplan.2010.06.011.
- Sop Shin, Won. 2007. "The influence of forest view through a window on job satisfaction and job stress." *Scandinavian Journal of Forest Research* 22 (3):248-253.
- Tanner, C Kenneth. 2009. "Effects of school design on student outcomes." *Journal of Educational Administration* 47 (3):381-399.
- Taylor, A. 2002. "Views of nature and self-discipline: Evidence from inner city children." *Journal of Environmental Psychology* 22 (1-2):49-63. doi: 10.1006/jevp.2001.0241.
- Ulrich, Roger. 1984. "View through a window may influence recovery." *Science* 224 (4647):224-225.
- Wells, N. M. 2000. "At home with nature: Effects of "greenness" on children's cognitive functioning." *Environment and Behavior* 32 (6):775-795. doi: 10.1177/00139160021972793.
- Wu, Chih-Da, Eileen McNeely, JG Cedeño-Laurent, Wen-Chi Pan, Gary Adamkiewicz, Francesca Dominici, Shih-Chun Candice Lung, Huey-Jen Su, and John D Spengler. 2014. "Linking student performance in Massachusetts elementary schools with the "greenness" of school surroundings using remote sensing." *PloS one* 9 (10):e108548.

Life cycle assessment of urban vs. suburban residential mobility in Chicago

Peng Du¹, Antony Wood¹, Brent Stephens²

¹Illinois Institute of Technology/Council on Tall Buildings and Urban Habitat, Chicago, IL

²Illinois Institute of Technology, Chicago, IL

ABSTRACT: In the United States, metropolitan area population increased from 69 percent of the total population in 1970 to 80 percent in 2000, but the population has continued to suburbanize within the metropolitan areas. This phenomenon is especially highlighted in Chicago. The population of the City of Chicago peaked at 3.6 million in 1950, containing 70 percent of metropolitan area residents. By 2000, 2.9 million Chicagoans made up only 36 percent of the region's population. Also, vehicle miles traveled (VMT) on U.S. highways has been increasing at a much faster rate than either population or developed land for several decades.

It is widely accepted that dense or compact city should be more "sustainable" due to higher energy efficiency in higher residential density along with greater accessibility to city facilities, and shared infrastructure. A key question of interest is the extent to which developing more compactly would reduce VMT and make alternative modes of travel (i.e., walking, bicycling, public transit, etc.) more feasible. Yet, there are very few studies that conduct a comprehensive energy and environmental life-cycle measure of residential mobility in different urban patterns, in terms of location, travel behavior, accessibility, etc.

The research outlined in the paper conducts a life-cycle assessment (LCA) of residential mobility within three urban scenarios in Chicago: Chicago Loop as a high dense downtown district, Oak Park as a less dense suburb close to the downtown, and Aurora as a much less dense suburb far away from the downtown. In these three cases the research quantifies and compares the life-cycle energy in resident travel through different modes of transport such as automobile, bus, CTA train, and Metra, including such LCA components as vehicle manufacturing & maintenance, vehicle operation, infrastructure construction & operation, etc. The study proves the denser area with shorter commuter distance consumes less life-cycle energy of residential mobility.

Due to the complexity of residential mobility, the metropolitan region could be the best geographic scale for transportation LCA integration, and LCA can and should be used as a valuable guiding framework for novel mitigation strategies. Based on the case studies in Chicago Metropolitan area, the paper provides an alternative perspective for policy and decision makers to incorporate life-cycle thinking into planning.

KEYWORDS: LCA, Sustainability, Transportation, Infrastructure, Embodied Energy

INTRODUCTION

The United Nations forecasts that 70 percent of the world's projected nine billion populations will be urbanized by the year 2050, up from 51% of seven billion urbanized as of 2010¹. The enormity of this total figure of 2.8 billion people moving into cities over the next 40 years is perhaps more clearly appreciated when converted into an annual rate of 70 million people per year, or a daily rate of nearly 200,000 people. That means that the human race needs to build a new or expanded city of more than one million people every week for the next 40 years to cope with this urban growth. The key question is: how are these new millions of urban inhabitants best accommodated – in the horizontal city, or the vertical city?

The U.S. population has continued to urbanize and suburbanize. As a share of total population, metropolitan population increased from 69 percent in 1970 to 80 percent in 2000 (Hobbs and Stoops 2002 in Giuliano et al. 2008, 11). Within metropolitan areas, however, the population has continued to suburbanize. From 1970 to 2000, the suburban population slightly more than doubled, from 52.7 million to 113 million². This phenomenon is especially highlighted in Chicago, where there has been a huge population shift from city to suburbs over the last half of 20th century. The population of the City of Chicago peaked at 3.6 million in 1950, containing 70 percent of metropolitan area residents. By 2000, 2.9 million Chicagoans made up only 36 percent of the region's population³.

Yet, these dispersed, automobile-oriented suburbanized patterns have resulted in consuming vast quantities of undeveloped land, and increasing vehicle miles traveled (VMT), which contribute to increasing energy usage. Specifically, passenger vehicle travel on U.S. highways has been increasing at a much faster rate than either population or developed land for several decades (Transportation Research Board, 2009).

It is widely accepted that the concentration of people in denser cities – sharing space, infrastructure, and facilities – offers much greater energy efficiency than the expanded horizontal city, which requires more land usage as well as higher energy expenditure in infrastructure and mobility. A key question of interest is the extent to which developing more compactly would reduce VMT and make alternative modes of travel (i.e., walking, bicycling, public transit, etc.) more feasible. Yet, there are very few studies that conduct a comprehensive energy and environmental life-cycle measure of residential mobility in different urban patterns, in terms of travel behavior, shared infrastructure, etc. This research project could thus hardly be important, and looks to fill a massive research gap.

1.0 LIFE CYCLE ASSESSMENT

Life cycle assessment (LCA) studies the environmental aspects and potential impacts throughout a product's life (i.e. cradle-to-grave) from raw material acquisition through production, use, and disposal (ISO, 1997). By including the impacts throughout the product life cycle, LCA provides a comprehensive view of the environmental aspects of the product or process and a more accurate picture of the true environmental trade-offs in product and process selection. Figure 1 illustrates the possible life cycle stages that can be considered in an LCA and typical inputs/outputs measured.

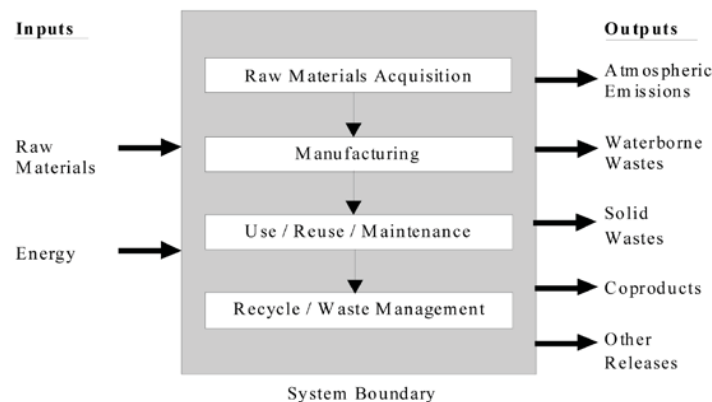

Figure 1: Life cycle stages. Source: (EPA, 1993)

Life cycle energy can also be expressed as a sum of Embodied Energy + Operating Energy. Embodied energy typically consists of three main elements: initial embodied energy, recurring embodied energy and demolition energy. Compared to embodied energy, operating energy is an ongoing and recurrent expenditure of energy that is consumed to satisfy the demand for day-to-day operation process.

In transportation systems, LCA is a framework for assessing the energy use and resulting environmental impacts of mobility from well-to-wheels. Recent studies have developed a comprehensive environmental LCA for automobiles, buses, trains, and airplanes in the US, including vehicles, infrastructure, fuel production and supply chains (Chester 2008, Chester and Horvath 2009). Specifically, the components inventoried in vehicles include manufacturing, operation, maintenance, replacement and insurance, and the components inventoried in infrastructure include construction, operation, maintenance, parking insurance, etc.

Based on the methodological framework and database from Chester et al, the research outlined in the paper conducts a LCA of residential mobility within three urban scenarios in Chicago to specifically quantifies and compares the life-cycle energy in resident travel through different modes of transport such as automobile, bus, CTA train, and Metra, including vehicles manufacturing, maintenance & operation, and infrastructure construction, maintenance & operation, etc.

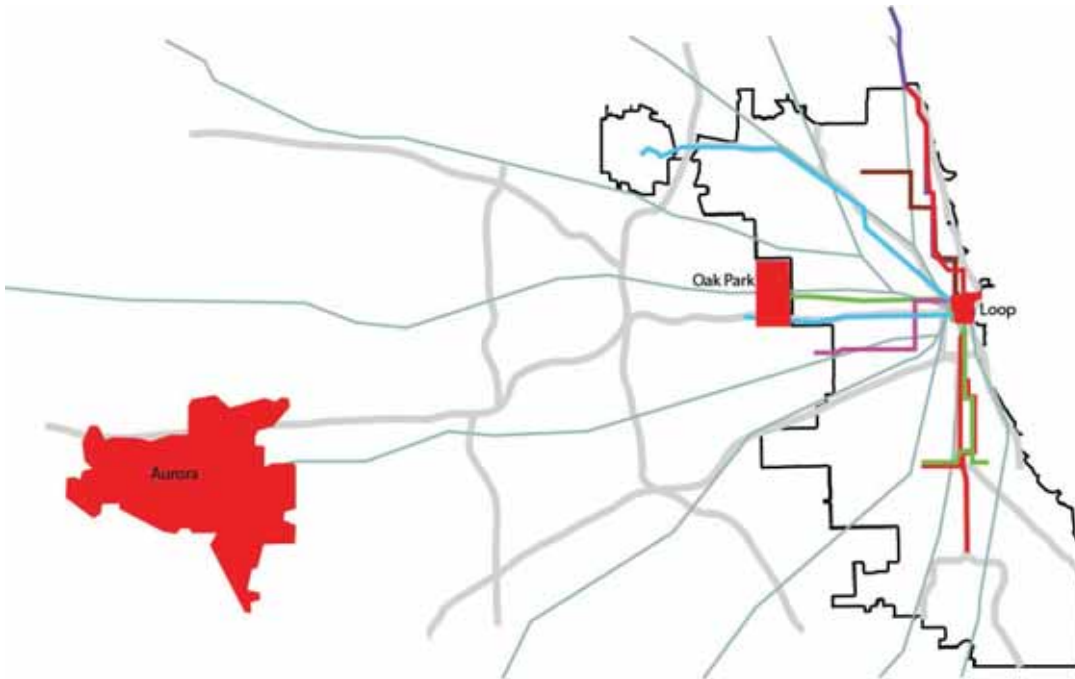

Figure 2: Site location and transportation systems (including CTA train lines, Metra lines and major highways) of the 3 case studies. Source: (Author 2014)

Chicago Loop, as the primary destination of commuter in Chicago metropolitan area, integrates all public transportation train lines and multiple buses. High dense residential community dominates the housing type in the Loop. Oak Park located about 8 miles from Chicago city center has easy access to downtown Chicago (the Chicago Loop) via public transportation, such as the Chicago 'L' Blue and Green lines, CTA buses and Metra commuter rail. Actually, Oak Park is a relatively dense mixed community of single-family homes and apartment blocks. Aurora located about 50 miles from Chicago city center has relatively limited public transportation system. Aurora is the final stop of the Metra BNSF Line connecting to Downtown Chicago, and also operates Pace suburban bus connecting to the surrounding cities. Single-family housing dominates the housing type in Aurora. Figure 3 shows the differences in the urban fabrics of the three study areas.



Figure 3: Urban Fabrics of Chicago Loop (Left), Oak Park (Middle) and Aurora (Right). Source: (Author 2014, images from Bing Maps)

Table 1 outlines the basic characteristics of the three study areas. Generally, it shows that the denser area has lower VMT as we all have already known. However, factors that affect VMT are various, including demographic characteristics, access to jobs, proximity to business and amenities, availability of public transportation, neighborhood walkability, etc. The research quantifies and compares the life-cycle energy in the residential mobility via different modes cross the three urban scenarios.

Table 1: Basic characteristics of the three study areas. Source: (Author 2014, data from 2010 and 2012 Census, 2011 American Community Survey five-year estimates, CMAP calculations of US Census Bureau, and Illinois Secretary of State)

Characteristics/Study Areas	Chicago Loop	Oak Park	Aurora
Urban Pattern	Downtown	Inner commuter suburb	Outer commuter suburb
Population	29,283	51,878	199,932
Density	7,200/km ²	4,262/km ²	1,433/km ²
Distance to Downtown	Walkable	Avg. 8 miles	Avg. 50 miles
Avg. Household Size	1.8	2.4	3.2
Median Number of Rooms	3.7	5.4	5.8
Avg. Vehicle Number per HH	0.67	1.61	1.8
Avg. Annual VMT per HH	6,949 miles	13412 miles	20,931 miles
Avg. Annual VMT per Person	3,860.6 miles	5588.3 miles	6540.9 miles
Public Transportation	All CTA Lines, All Metra Lines & Multiple Bus Lines	Green & Blue CTA lines, Metra UP-West Line & Pace Buses	Metra BNSF Line& Pace Buses

According to the 2008 Household Survey⁴ Share of Total Mileage of Travel by Mode by Residents of each Zone, the total mileage traveled per person by public transportation modes can be calculated as shown in Table 2. Due to the limited open data about the travel behavior via public travel mode and the geographic characteristics, the study assumes that the share of total mileage of travel by mode in Loop is the same as Central Chicago zone, Oak Park is the same as West Cook zone, and Aurora is the same as Eastern Kane zone.

Table 2: Annual mileage traveled per person by different transportation modes in different study areas. Source: (Author 2014)

Study Areas/Mode	Automobile	CTA/Pace Bus	School Bus	CTA Train	Metra
Loop	3860.6	737.4	23.2	552.1	139
Oak Park	5588.3	145.3	117.4	424.7	357.7
Aurora	6540.9	6.5	91.6	0	510.2

2.1. Methodology

The study quantifies the energy inputs of annual mobility per person via different transportation modes, including automobile, CTA/Pace/school bus, CTA train, and Metra, associated with the life cycles of vehicles and infrastructure in Chicago Loop, Oak Park and Aurora.

System boundary selection is a critical first step in LCA to establish a consistent scope for comparing alternatives. Based on the system boundary selected in the study, the embodied energy of vehicle includes the energy consumed in vehicle manufacturing and maintenance process, and the embodied energy of infrastructure includes the energy consumed in the construction and maintenance process for the infrastructure. Table 3 outlines the system boundary of analysis with life cycle groupings and generalized life cycle components for each of the transportation modes.

Table 3: Life cycle assessment of the system boundary. Source: (Author 2014)

Life Cycle Grouping/Mode	Automobile	CTA/Pace/School Bus	CTA Train/Metra
Vehicle			
Manufacturing	Manufacturing	Manufacturing	Manufacturing
Maintenance	Typical Maintenance Tire Replacement	Typical Maintenance Tire Replacement	Routine Maintenance Flooring Replacement
Operation	Propulsion	Propulsion Idling	Propulsion Idling HVAC
Infrastructure			
Construction	Roadway Parking	Roadway	Station Station Parking Track
Maintenance	Parking	Roadway	Station Station Parking Track
Operation	Roadway Lighting	Roadway Lighting	Station Lighting Station Parking Lighting Station Escalators Station Train Control Station miscellaneous

For each component in the transportation mode’s life cycle, environmental performance is calculated and then normalized per Passenger-Mile-Traveled (PMT). The travel modes have different life-cycle energy profiles as shown in Table 4, which outlines the energy per PMT of four different transportation modes including automobile, bus, CTA train and Metra. It shows the vehicle of each mode consumes more operating energy than its embodied energy per PMT, but the infrastructure of each mode requires more embodied energy than operating energy per PMT. It also demonstrates the energy in vehicle operation shares the largest portion in each mode, especially in automobile and bus.

Table 4: Energy data per PMT of multiple transportation modes. Source: (Author 2014, data from: Transportation LCA Database)⁵

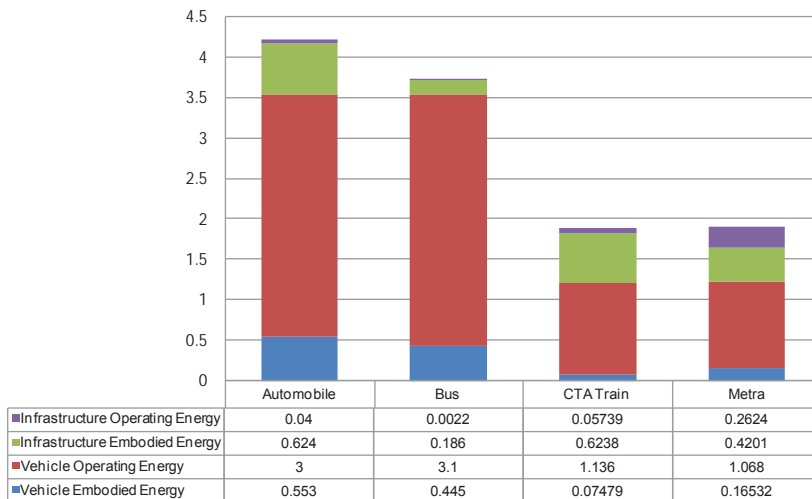

3.0. RESULTS AND COMPONENT COMPARISONS

Based on the data in Table 2 and Table 4, the life-cycle energy associated with annual mileage traveled per person via different transportation modes across different urban patterns can be calculated. All energy inputs showed in the paper are converted to Megajoules (MJ) for an equivalent comparison.

Figure 4 proves that the denser area with shorter commuter distance consumes less life-cycle energy of residential mobility. Specifically, the left diagram shows the operating energy dominates the life-cycle energy (on average, the operating energy counts for almost 99% in total life-cycle energy in the all three cases), which again emphasizes on the importance of reducing the actual VMT, and developing alternative modes of travel without operating energy, e.g., walking and bicycling. The right diagram demonstrates the total energy consumption by vehicle itself is far more than its supporting infrastructure, which means we can either reduce the usage (i.e. less travel) or the amount of vehicles (i.e. carpool). Also, the Chicago Loop has the most complicated and densest transportation system, but the energy consumption of infrastructure is the least at a per-capital basis, which confirms the benefits of the shared transportation infrastructure in the dense areas of the city. On the contrary, Aurora, a typical American suburb with limited public transportation support (one Metra line and a few Pace Bus lines only) consumes the greatest energy of the infrastructure, which demonstrates the highway network is a major contributor to the energy consumption of the infrastructure from a life-cycle perspective.

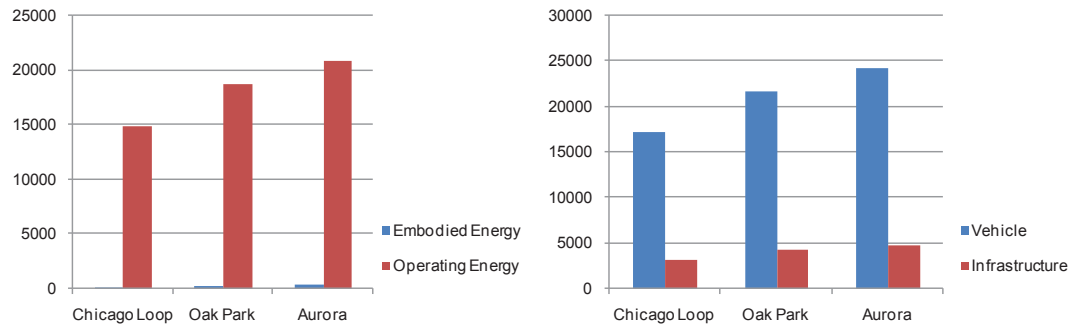

Figure 4: Total embodied energy and operating energy (left), and total energy consumption by vehicle and supporting infrastructure (right) across the three urban scenarios. Source: (Author 2014)

Figure 5 provides more findings about the embodied energy and operating energy by both vehicle and infrastructure for each transportation mode across the three different study areas. It shows the less dense area with longer commuter distance consumes more energy via automobile and Metra, and less energy via bus and CTA trains. Specifically, the embodied energy by vehicle for automobile shares greater percentage in the total energy than any other vehicle types, which further demonstrates the significance to reduce the amount of cars, i.e. the car number per household. Thus, it is critical to provide alternatives to car ownership, including support car-sharing (i.e., Zipcar), facilitate carpooling and build bicycle infrastructure and facilities (i.e., Chicago Divvy Bikes). Also, the embodied energy and operating energy by infrastructure for bus share less portion in the total energy than either CTA train or

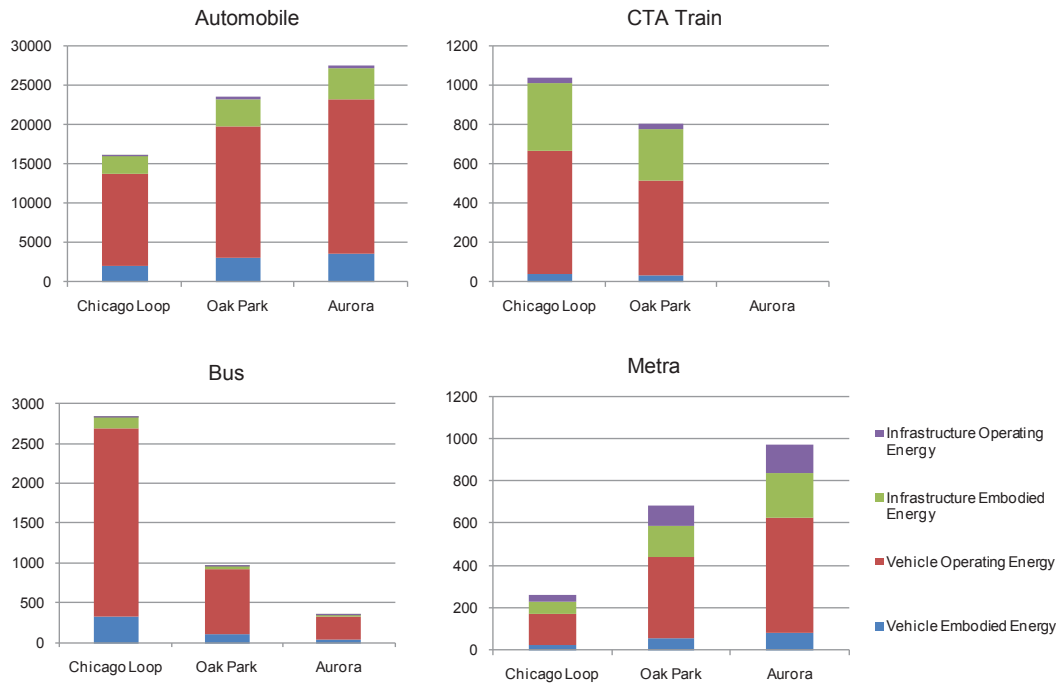

Figure 5: Life-cycle energy analysis in each transportation mode (automobile, bus, CTA train and Metra) cross the three different study areas. Source: (Author 2014)

CONCLUSION

The research shows either the embodied energy or the operating energy shared per person via automobile is far more than the sum of all other public transportation modes in the Chicago Loop, Oak Park and Aurora (see Figure 6). This confirms the benefits of transit-oriented development (TOD), and also demonstrates that reducing automobile usage and new roadway construction is a key point in lowering the energy consumption in the residential mobility. Thus, the policies that support more compact, mixed-use development and reinforce its ability to reduce VMT and energy use should be encouraged.

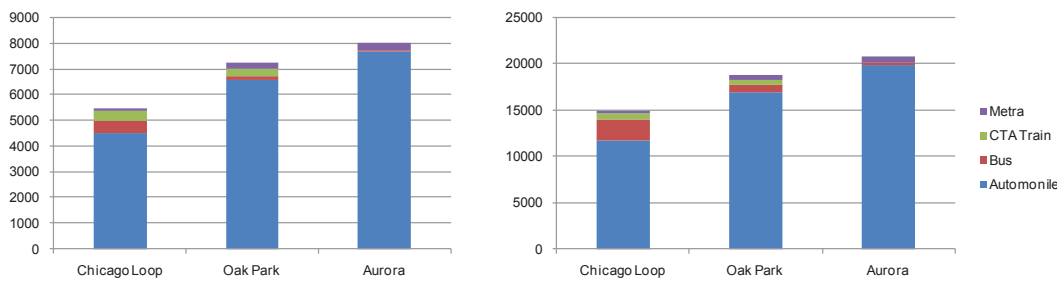

Figure 6: Annual total embodied energy (left) and operating energy (right) per person via different transportation modes cross the three urban scenarios. Source: (Author 2014)

Due to the complexity of residential mobility, the metropolitan region could be the best geographic scale for transportation LCA integration, and LCA can and should be used as a valuable guiding framework for novel mitigation strategies. Based on the case studies in Chicago Metropolitan area, the study incorporates life-cycle thinking into urban planning and transportation planning by conducting a LCA in residential mobility via multiple modes of transport in different urban locations, and analyzes the policy implications of life-cycle energy. Yet, to rely on transit and technology only to achieve sustainability in mobility is not realistic. Further work should also focus on the housing location selection and travel preferences in a more detailed level.

ACKNOWLEDGEMENTS

The authors gratefully acknowledge support from the Council on Tall Buildings and Urban Habitat.

REFERENCES

- Banister, D., Watson, S. and Wood, C. 1996. Sustainable Cities: Transport, Energy, and Urban Form. *Environment and Planning B: Planning and Design.*, Vol. 24, pp.125-143
- Chester, M., et al. 2013. Infrastructure and Automobile Shifts: Positioning Transit to Reduce Life-cycle Environmental Impacts for Urban Sustainability Goals. *Environmental Research Letters*.
- Chester, M., et al. 2013. Integrating Life-cycle Environmental and Economic Assessment with Transportation and Land Use Planning. *Environmental Science & Technology*, 47(21), 12020-12028
- Chester, M. 2008. Life-cycle Environmental Inventory of Passenger Transportation Modes in the United States. Doctoral Dissertation.
- College of Urban Planning and Public Affairs, University of Illinois at Chicago. 2001. Metropolitan Decentralization of Chicago.
- Du, P., Wood A. 2014. CTBUH Research Project on the Sustainability Implications of Urban & Suburban Locations – Initial Report. 2014 CTBUH Shanghai Conference Proceedings. 16th – 19th September, 2014. Shanghai, China. Published by the Council on Tall Buildings and Urban Habitat, Chicago. pp.410-417.
- Naess, P. 2006. *Urban Structure Matters: Residential Location, Car Dependence and Travel Behavior*. Routledge, New York, US
- Naess, P. 2006. Accessibility, Activity Participation and Location of Activities: Exploring the Links between Residential Location and Travel Behavior. *Urban Studies*, Vol. 43, No. 3, pp.627-652, March 2006
- Perkins, A., Hamnett, S., Pullen, S., Zito, R. and Trebilcock, D. 2007. Transport, Housing and Urban Form: The Life Cycle Transport and Housing Impact of City Centre Apartments Compared with Suburban Dwellings. State of Austrian Cities National Conference. Adelaide, South Australia
- Pincetl, S., Chester, M., Circella, G., Fraser, A., Mini, C., Murphy, S., Reyna, J., and Sivaraman, D. 2014. Enabling Future Sustainability Transitions. *Journal of Industrial Ecology*.
- Williams, K., Burton, E. & Jenks, M. 2000. *Achieving Sustainable Urban Form*. E & FN Spon, New York, US
- Wood, A., Johnson, T. & Li, G.Q. (ed.). 2012. *Asia Ascending: Age of the Sustainable Skyscraper City*. Proceedings of the CTBUH 9th World Congress, 19-21 September, 2012. Shanghai, China. Published by the Council on Tall Buildings and Urban Habitat, Chicago. Introduction, pp.14-23.

ENDNOTES

¹ Source: Population Division of the Department of Economic and Social Affairs of the United Nations Secretariat, *World Population Prospects: The 2006 Revision and World Urbanization Prospects: The 2007 Revision*, <http://esa.un.org/unup>

² Source: U.S. Bureau. U.S. Bureau of the Census does not identify a location as “suburban.” Metropolitan areas are divided into two classifications: (a) inside central city and (b) outside central city. Many researchers treat the latter areas as suburban, and they are so treated in this paper (see Giuliano et al. 2008, Appendix B).

³ Source: Metropolitan Decentralization of Chicago. College of Urban Planning and Public Affairs, University of Illinois at Chicago. July 2001.

⁴ The Chicago Regional Household Travel Inventory (CRHTI) did a comprehensive study of the demographic and travel behavior characteristics of residents in the greater Chicago area.

⁵ The transportation LCA database (tLCAdb) is a repository of greenhouse gas environmental results from research developed by Dr. Mikhail Chester, Dr. Arpad Horvath, and colleagues. www.transportationlca.org/. In this Chicago-based study, the automobile was assumed equivalent to a regular sedan, the CTA bus and school bus are equivalent to an average bus, the CTA train is equivalent to San Francisco’s BART, and Metra is equivalent to San Francisco’s Caltrain.

Method for estimating energy use intensity based on building façade

Chao Yang¹, Joon-Ho Choi¹, Douglas Noble¹, Marc Schiler¹

¹University of Southern California, Los Angeles, CA

ABSTRACT: Commercial and residential buildings are tremendous users of energy, accounting for more than 72% of electricity use in the U.S. Among the main building performance factors (i.e., enclosure, system, and control), that influence a building's energy performance, building façade features are one of the major parametric elements. The recorded Energy Use Intensity (EUI) of existing buildings performance come from relevant organizations (such as CBECS and USGBC), which contain aggregated energy performance information (based on the ranges of certain parameters), but it is difficult to identify the specific condition of each building category within a selected climate zone. In addition, the averaged performance data is too general to determine if a specific building is energy efficient or not. On the other hand, it is very time-consuming to develop a simulation model in software to each case, which also needs very detailed information about geometry, system, and operation schedule and control modes. This is because an accurate energy performance prediction mainly depends on a variety of detailed data about indoor thermal conditions, mechanical system performance, occupancy level, etc. In this research, a vision-based performance prediction model was developed to estimate building energy consumption based on simplified façade attribute information and weather conditions. Building façade features, including shading, window-to-wall ratio, orientation, surface-to-volume ratio, etc., were collected along with the energy performance records from New York City building energy benchmarking database. Based on this training dataset, a prediction model was established to estimate annual energy use. The developed estimation model adopted architectural physical attributes and their dynamic ambient environmental conditions as input variables. This prediction approach will provide a more specific baseline and goal especially in the pre-design phase, it also could assess EUI by a minimum amount of data.

KEYWORDS: EUI, Baseline Model, Regression, Façade Features

INTRODUCTION

In 2010, the U.S. consumed 97.8 quads of energy, which represented 19% of global energy consumption (Program and Efficiency 2012). The buildings sector in the United States, including residential and commercial buildings, accounted for about 41% of primary energy consumption in 2010. Space cooling, space heating and lighting are the dominant end uses, which accounted for about 52% of total energy consumed by buildings sector. Façade features, such as exterior wall type, glazing type, shading type, window-to-wall ratio, etc., have a great influence on space heating, cooling and even lighting demand (Shan 2014). A good building façade design will be greatly useful to reduce energy demand by selecting appropriate façade features according to local climate characteristics.

Energy Use Intensity (EUI) represents a building's energy use as a function of its size or other characteristics, which is calculated by dividing annual building energy consumption in one year by the total gross floor area as kBtu/sf. EUI is a very important indicator (Andrews and Krogmann 2009) to evaluate building energy performance and energy saving potential. Annual EUI could also be the baseline for building owners and designers to set a reasonable energy reduction goal for the following years.

Architecture 2030 was established to promote energy reduction by changing buildings into a solution of global energy crisis (Architecture 2030 2011). Architecture 2030 uses the Commercial Buildings Energy Consumption Survey (CBECS) 2003 data, which provides national and regional medians as the baseline. CBECS is a national sample survey ("About Commercial Buildings Energy Consumption Survey" 2012) that collects information on the stock of U.S. commercial buildings, including their energy-related building characteristics and energy usage data. Energy use intensity (EUI) baseline currently relies on a national or local energy usage average based on census division, climate zone, building size or year constructed. These factors can't represent the specific physical condition of each building, since it doesn't consider individual building features and local climate condition. The average EUI value based on certain census

division, climate zone or HDD/CDD (heating degree day/cooling degree day) range, is also too general to categorize weather condition.

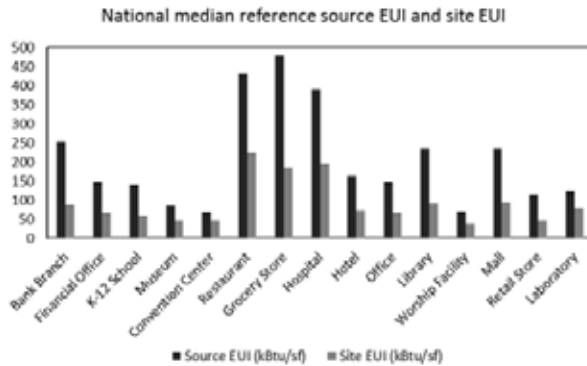

Figure 1: National median reference EUI of selected building types. Source: (Energy Star 2014)

Demands from urban planners and building designers require a new method to predict building energy use through a simple way at the beginning of design stage, which could be based on easily accessible information. Many mathematical methods were used to calculate building energy use other than computer simulation which depends on building detailed information input. Rajesh et al. (Kumar, Aggarwal, and Sharma 2013) used Artificial Neural Network (ANN) to estimate total energy use for heating and carbon emissions. The results presented the total load for a six stories building by using ANN method which collected data representing the past history and performance of the real system. Decision tree method is another approach to predict building energy use in practice. Zhun et al. (Yu et al. 2010) demonstrated that a decision tree method can predict building energy demand by 93% accuracy for training data and 92% accuracy for test data. Case-based reasoning (CBR) was used by Danielle et al. (Monfet et al. 2014) to forecast building energy demand and the model was validated by real monitored data. The advantages of using CBR include easily updating feature, simple understanding of reasoning, ability to deal with missing information and large amounts of predictors. Regression model based on basic visualized building façade features is a feasible alternative to estimate building energy consumption instead of using average data from survey or running simulation in complicated software. The main goal is to develop a customized baseline model considering specific façade features and local climate condition. Due to its simplicity and quick processing time, the model would be applicable to set a reasonable EUI reduction baseline for building performance management and improvement. In addition, the impact of basic façade features on energy performance in different climate zone could be clearly presented by sensitivity analysis in order to provide a guideline of how façade features could influence building energy use based on real energy database. The result could also draw more attention on the significance of building energy use disclosure to public from government benchmarking policy.

1.0 METHODS

Multiple regression models are developed to predict energy performance by entering a minimum number of façade data. Instead of using details of building information, like construction thermal properties, mechanical system, operation schedule, etc., multiple linear regression is adopted with easily accessible façade features, which include building height, orientation, volume, floor area, façade area, site area, window-to-wall ratio, volume-to-façade area ratio, etc.

There are mainly three parts of the methodology: data collection (DC), data processing (DP), and model development (MD) as represented in Figure 2.

1. For data collection, generally 2 types of data should be collected. One is real energy use data, another is corresponding façade feature. Energy use data is presented by Energy Use Intensity (EUI) as the target metric from building energy benchmarking and disclosure data by local government. On the other hand, façade features are collected by using different methods which contain manual estimation (visual reading and physical model rebuilding), existing building model reading (SketchUp etc.) and direct information collection from design drawing or specification.

Other potential factors like built year and HDD/CDD could also be easily obtained from open resources.

2. Data processing section is served as data preparation for the following model development. For annual EUI model development, this step could be skipped since annual EUI data is the basic data provided by different building energy resources.
3. Finally, multiple linear regression is used to develop the EUI estimation model package based on collected façade information and EUI data. In this section, the significance of each predictor and correlation between predictors and response could also be analyzed with the consideration of local code requirements, design strategies and best practices. Other regression methods would be used for comparison, which include stepwise regression. In the end, all regression models should be validated by appropriate method.

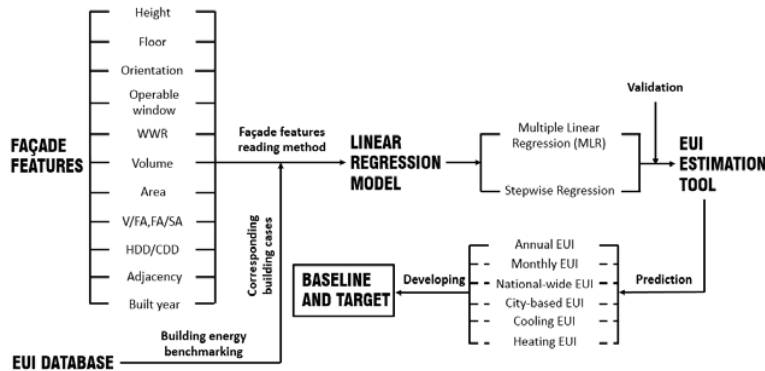

Figure 2: Methodology.

The predicted outcome of this research is a new EUI estimation package, which could provide building EUI baseline at different scale. In this paper, the annual office EUI estimation model in New York City is the expected result.

1.1. EUI data collection

Building energy benchmarking is a method to get building energy data as a baseline to compare to other properties performance. It will give owners a better understanding of how much energy their buildings exactly consume for a time period and how much energy reduction potential they can get when adopting energy efficient measures. To accomplish the task of benchmarking, the energy monitoring and recording are needed, and the data should be submitted by using a common format to be available to put into database. The most commonly used tool is Portfolio Manager developed by EPA (Energy Star 2014), which is normally used to track and evaluate energy use for commercial buildings. The benefits of using benchmarking (Milliken and Jones) to keep track of building energy use are listed in the following figure 3.



Figure 3: U.S. Building benchmarking and transparency policies. Source: (IMT 2014)

In U.S. there are 9 cities (IMT 2014) which committed to implement energy benchmarking and disclosure programs for commercial buildings (Cox, Brown, and Sun 2013), which include Seattle, San Francisco, Austin, Minneapolis, Cambridge, Boston, New York City, Philadelphia, Washington, DC, etc. In New York City, benchmarking policy of Local Law 84 (LL84), part of Greener, Greater Buildings Plan (GGBP) was

adopted in 2009 (GGBP 2013), which requires all non-residential buildings with floor area over 50,000 square feet to submit and disclose their building energy and water data to the city. The results show that the median source EUI for office properties in 2010 and 2011 are 213.3 kBtu/sf and 207.3 kBtu/sf and the median Energy Star score increased from 64 to 67.

In this paper, office building energy benchmarking data in New York City are used to develop an exemplary regression model which could predict annual energy use for office buildings in New York City. 99 office buildings in Manhattan, New York City from the benchmarking database are firstly selected. Then 28 buildings with existed SketchUp model are further sorted out in order to read the façade features easily and accurately. In most selected buildings there are 2 years of reported energy data available (24 of them have both years). In total 50 datasets with full information of both real EUI and façade features are the basis for the further regression analysis.

1.2. Façade feature definition

All building façade features could be easily readable without knowing detailed information. Generally, geometry attributes are the basic predictors. Roof or wall R-value, window U-value and SHGC, etc. are not used since the fabric information are not accessible without the permission from owner or designer. The original 17 predictors are showed in the table below which explains the definition of each parameter.

Table 1: Predictors definition and explanation.

No.	Façade feature	Definition
1	Height	From open air pedestrian entrance to highest occupied floor ¹
2	Floors	Total occupied stories or levels ²
3	Orientation	Positing of a building with respect to the North ³
4	Operable window	Window could be open or close based ventilation need ⁴
5	Volume	Inner space volume enclosed by external envelope
6	WWR	Window-to-wall ratio (total window area/total exterior wall area)
7	Window Area	Total glazing area
8	Façade Area	Total area of all parts of the structure's façade
9	Site Area	Total site area within fixed boundaries
10	Floor Area	Total floor area inside the building envelope
11	V/FA	Ratio of volume to façade area
12	V/SA	Ratio of volume to site area
13	FA/SA	Ratio of façade area to site area
14	HDD	Heating degree day (the demand for energy to heat a building)
15	CDD	Cooling degree day (the demand for energy to cool a building)
16	Adjacent Building	If adjacent building exists to cast shading on objective building ⁵
17	Built Year	Year of construction complete

Note: 1. Height is measure from the level of the lowest, significant, open-air, pedestrian entrance to the finished floor level of the highest occupied floor within the building (Council on Tall Buildings and Urban Habitat).

2. Floors refer to the total levels of a building which could be used by occupants.

3. Long axis along with North-South is quantified as 1, NE-SW is 2, E-W is 3, SE-NW is 4.

4. With operable window is quantified as 1, without operable window is quantified as 0.

5. No adjacent building is quantified as 0, while adjacent building on the north side is 1, others are clockwise defined by 2 to 8.

In this research, a basic assumption is that EUI could be estimated only based on simple façade features as well as a few other factors, like HDD/CDD which represents dynamic local weather condition. Another factor built year is used to take all the requirements by code in each time period into consideration. It assumed that after the first national/local building energy code established a building had to meet the requirements of corresponding codes or standards, including fabric thermal performance, system efficiency, ventilation rate requirements, etc. The built year is easy to obtain as a basic building information. In addition, since in urban context, adjacent building will cast shades on objective buildings which in turn will influence heat gain through the façade especially glazing area, adjacency is another factor which is collected for regression analysis.

1.3. Regression method

To develop regression model, many tools could be considered for analysis, like SPSS Statistics (IBM 2014), MATLAB (MathWorks 2014), etc. In this research, another statistical analysis tool, Minitab® 17 (Minitab 2014) is used for data analysis and regression model development. By using Minitab, a large amount of data can be processed (Minitab 2013) for basic statistical analysis, regression and correlation analysis, hypothesis tests, model validation, prediction, and graphs making, etc. All façade features and EUI data can be input as basic training samples. The correlation between each factor and EUI could be analyzed by calculating Pearson's correlation coefficient. Then different regression models could be compared to determine the most accurate model which is sufficient to predict response values for new observations.

Rather than only using one independent variable as predictor in regression, multiple linear regression (MLR) has multiple independent variables. The same purpose as simple linear regression is to develop the relationship between response and predictors and predict the new response with a new set of predictors at an acceptable confidence level. The multiple linear regression is presented as the following form:

$$EUI = a + b_1x_1 + b_2x_2 + b_3x_3 + \dots + b_kx_k + \varepsilon \quad (1)$$

Where

a is the constant while b_1, \dots, b_k are the regression coefficients, b_1, \dots, b_k are the significant predictors and ε is the random error.

In addition, when there are a large number of predictors to be used in regression, stepwise regression should be used to removing the least significant predictor at each step. The order of removed predictors also indicate the significance which could be analyzed to determine which predictor is the most important one in a certain area. This is also called backward elimination (Support Minitab 2014). This automatic process is useful to identify the most significant predictors. To analyze the results of regression models, multiple indicators could be calculated to evaluate the characteristics of the corresponding models. The main indicators are listed in the table 2.

Table 2: Key indicators in regression model.

No.	Indicator	Explanation	Accepted Range
1	<i>Pearson Correlation</i>	Whether 2 continuous variables are linearly related	(-1,1)/closer to 1
2	<i>P-value</i>	The probability of obtaining a test statistic	(0,1)/closer to 0
3	<i>VIF</i>	Multicollinearity (correlation between predictors)	NA
4	R^2	Pct. of response variable variation can be explained	(0,100%)/closer to 100%
5	R^2 (<i>adj</i>)	R^2 adjusted for the number of predictors in the model	(0,100%)/closer to 100%
6	R^2 (<i>pred</i>)	Models predictive ability	(0,100%)/closer to 100%
7	<i>Durbin-Watson</i>	whether the correlation between adjacent error terms is 0	(1,3)/closer to 2
8	<i>Error rate</i>	discrepancy between the estimated values	NA/closer to 0

2.0 RESULTS AND DISCUSSION

2.1. Basic data analysis

All datasets with façade features were firstly analysed by dividing into different groups. The results represent the correlation between reported site EUI with each predictor through interval plotting. The confidence interval is 95% by default which indicates 95% probability from the future experiment within this interval.

Figure 4 indicates the correlation between site EUI and construction year, which divided data into 2 groups (before and after 1980), since the first New York state energy code was established in 1979 (U.S. DOE 2014). Office buildings that were built before 1980 have higher mean value of 102.06 kBtu/sf than 92.74 kBtu/sf after 1980. Even the confidence intervals are slightly overlapped, but with more strict requirements of building performance from improved energy code, buildings consume lower energy as expected. Tall buildings were grouped into megatall (more than 600 ft), supertall (300 to 600 ft) and tall (165 to 300 ft) for the analysis of height (CTBUH 2013). Figure 5 shows the significant difference of energy use for different height tall buildings. Megatall buildings consumed the highest energy, followed by super tall and tall buildings. National median site EUI of 67.3 kBtu/sf is only in the tall building EUI range. The overall 40% of

WWR for prescriptive fenestration requirement (NYCECC 2011) was used to divide all datasets into 2 groups and the results presented that WWR is a significant factor to influence office building energy use in terms of heating and cooling load by solar heat gain. The mean value of buildings with over 40% WWR was 107.88 kBtu/sf compared to 84.81 kBtu/sf for lower WWR buildings. Buildings with operable windows consumed less energy since the mixed mode of natural ventilation and mechanical ventilation is more energy efficient, which was proved by the fact that the mean value 84.9 kBtu/sf for buildings with operable window is lower than 104.25 kBtu/sf for buildings without operable window.

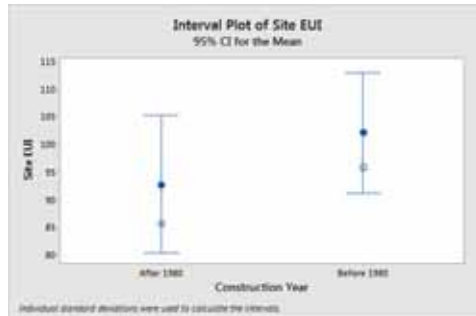

Figure 4: Site EUI (kBTU/sf) and construction year.

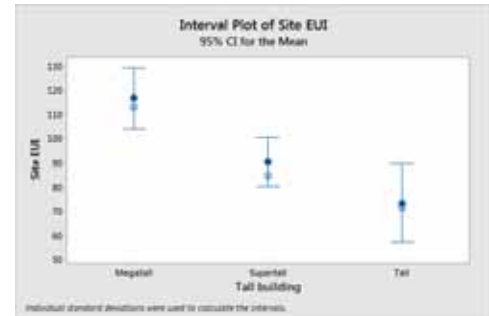

Figure 5: Site EUI (kBTU/sf) and building height.

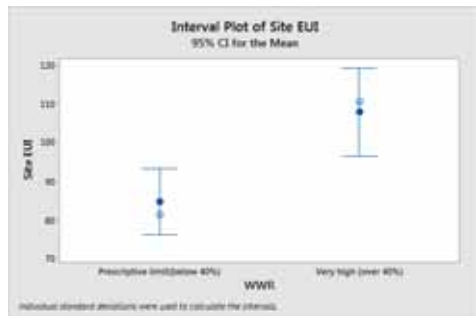

Figure 6: Site EUI (kBTU/sf) and WWR .

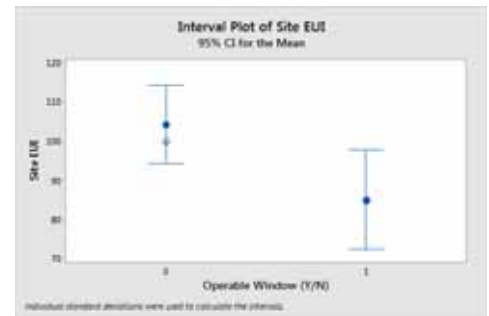

Figure 7: Site EUI (kBTU/sf) and operable window.

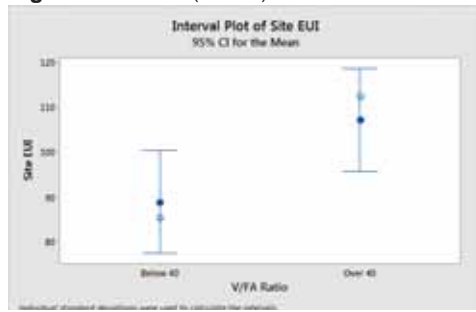

Figure 8: Site EUI (kBTU/sf) and V/FA ratio.

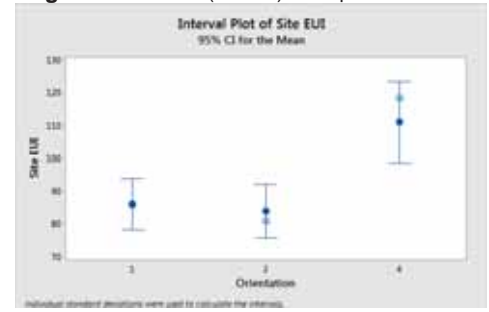

Figure 9: Site EUI (kBTU/sf) and orientation.

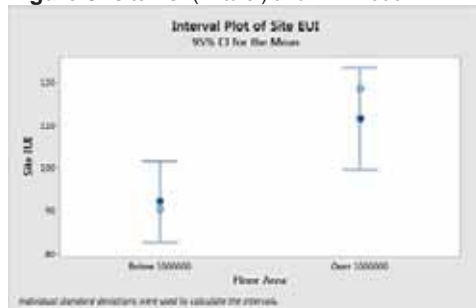

Figure 10: Site EUI (kBTU/sf) and floor area.

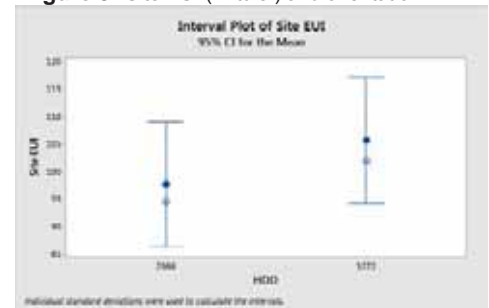

Figure 11: Site EUI (kBTU/sf) and HDD.

V/FA ratio stands for the compactness which has significant impact on heating load. Figure 8 illustrates that buildings with V/FA less than 40 had the lower mean EUI of 89.03 kBtu/sf, which means in this heating dominated area, compact buildings are not necessary consuming less energy than buildings with greater façade area. It also depends on glazing and exterior wall thermal performance and other factors. Figure 9 shows there was no significant difference of EUI between N-S orientation and NE-SW orientation while buildings with NW-SE had the highest mean EUI value of 111.01 kBtu/sf. It is because that the main façade facing south west has more heat gain through direct sun exposure. Figure 10 indicates that buildings floor area over 1000000 had significantly higher energy use than smaller area buildings. Another important predictor is heating-degree day which is extremely important for heating demand of a buildings. In total there are only 2 years energy data used in this regression research but it is clear that most buildings consumed more energy in 2011 than in 2012, which is showed in Figure 11, since the HDD of 3272 in 2011 is higher than 2988 in 2012 while other façade features didn't change within these 2 years.

2.2. MLR and stepwise regression

EUI can be predicted by the façade features through 2 methods: MLR and Stepwise Regression. The results are showed in table 3. Total façade area was replaced by 8 different direction façade area. In MLR, all 25 predictors were included in the every model. The R^2 value indicates that all predictors could explain 77.64% of the variance in EUI while the adjusted R^2 means only 56.18% of EUI variable variation can be explained by its relationship with predictor variables. D-W statistic is closer to 2, which means there is no significant autocorrelation. Only orientation and floor area are significantly related to annual EUI at an α -level of 0.05 since P-values are close to 0. VIF values for coefficients are greater than 10 which means the regression coefficients are poorly estimated due to severe multicollinearity.

By comparison, R^2 from stepwise regression means 88.15 % of the variance in EUI. The adjusted R^2 is also improved when compared to MLR. The predicted R^2 value is 77.72% which indicates the model does not appear to be overfit and has adequate predictive ability since it's close to R^2 and adjusted R^2 . All P-values of corresponding predictors are less than 0.05. The results showed the advantage by using stepwise regression is not only to improve each indicators of accuracy but also to identify a useful subset of predictors. The stepwise process systematically added the most significant variable or removed the least significant variable during each step. As a result, predictors including height, WWR, orientation, operable window, floor area, V/SA ratio, HDD as well as south and west façade area are the most important factors which have greater impact on energy use for office buildings in New York City.

Table 3: MLR and stepwise regression coefficients and indicators.

Determination	Multiple Linear Regression		Stepwise Regression	
R2/ R2 (pre)	77.64%	-	88.15%	77.72
Predictors	Coef	P-value	Coef	P-value
Constant	27302	0.174	-75.3	0.047
Height	0.087	0.593	0.1553	0.000
Floors	0.06	0.979	-	-
Built year	-0.339	0.586	-	-
WWR	0.542	0.507	0.719	0.000
Orientation	26	0.033	18.77	0.000
Operable Window	-29.9	0.15	-19.65	0.000
Volume	0	0.995	-	-
Window Area	0.000149	0.55	-	-
Site Area	0.00035	0.729	-	-
Floor Area	-0.00007	0.031	-0.000054	0.000
V/FA	-0.84	0.809	-	-
V/SA	0.185	0.515	0.1352	0.001
FA/SA	-10.29	0.11	-9.47	0.000
Adjacency	-1.85	0.502	-	-
HDD	5.86	0.178	0.0324	0.006
CDD	-22.7	0.181	-	-
N Façade Area	-0.01101	0.201	-	-
S Façade Area	0.125	0.23	0.001340	0.000
W Façade Area	-0.00249	0.2	-0.000634	0.009
E Façade Area	-0.0889	0.243	-	-
NW Façade Area	-0.000146	0.806	-	-
NE Façade Area	-0.00017	0.892	-	-
SW Façade Area	-0.000118	0.849	-	-
SE Façade Area	0.000571	0.471	-	-

Figure 12 illustrates that the predicted EUI from the developed MLR and Stepwise regression models, and the average error rates are 9.03% and 6.70% respectively. Both of the results are less than 10%, which are

better the static baseline from CBECS and TargetFinder. In addition, the dynamic results calculated by regression model are more meaningful and realistic as energy reduction baselines. Stepwise regression has higher predictive ability to estimate new observations, which could be used as the baseline estimation model.



Figure 12: Estimation results and site EUI.

CONCLUSIONS

To estimate building energy use, both simple multiple linear regression model and stepwise regression model were used and the results showed that stepwise is more reliable and accurate to predict EUI than MLR. Building EUI estimated by basic façade features is more specific since it considers the individual building attributes as well as local climate condition. The result is dynamic according to different features input which is better than one constant and median baseline from CBECS as the baseline. In addition to assist to EUI benchmarking for improving building energy efficiency, the research potential outcomes could be applied for new construction to provide a more accurate baseline and energy reduction target at the predesign stage and to evaluate basic façade design decisions. While for existing buildings, it can help to estimate EUI when there is no detailed building information available for deep simulation and get a reasonably correct energy consumption rate by inputting a minimum amount of data. Customized baseline could be more acceptable for building owners to know building energy saving potential and adopt measures to improve energy efficiency, which in turn will benefit energy conservation for the whole society.

The limitation of the simplified EUI estimation model is the limited range of application and the assumption that other important factors can be incorporated into “built year”. In this paper, EUI estimation model can be only used for office buildings in New York City. More data are needed to generate more regression models for different function of buildings and different climate zones or locations. In addition, other factors also have great influence on building energy use, such as envelope thermal properties, HVAC system efficiency, lighting fixtures, even building use schedules. Regression model based on simple façade features is more useful when no detailed data are available for energy use calculation no matter by simulation or real-time monitoring, so one of the basic precondition of using regression model is assuming when building was built in a certain period it had to meet all fabric and system efficiency requirements for corresponding code or standard. The future work could also consider the extended predictors when more information are available.

ACKNOWLEDGEMENTS

This research is made possible through the support of the Architecture 2030 Program and the support from voluntary participants of the Building Science and Master of Architecture Programs at the University of Southern California for the data collection.

REFERENCES

- "About Commercial Buildings Energy Consumption Survey." 2012. <http://www.eia.gov/consumption/commercial/about.cfm>.
- Andrews, Clinton J., and Uta Krogmann. 2009. "Technology Diffusion and Energy Intensity in US Commercial Buildings." *Energy Policy* 37 (2) (February): 541–553. doi:10.1016/j.enpol.2008.09.085. <http://linkinghub.elsevier.com/retrieve/pii/S0301421508005636>.
- Architecture 2030. 2011. "The 2030 Challenge." http://www.architecture2030.org/2030_challenge/the_2030_challenge.
- Council on Tall Buildings and Urban Habitat. "CTBUH Height Criteria." <http://www.ctbuh.org/TallBuildings/HeightStatistics/Criteria/tabid/446/language/en-US/Default.aspx>.
- Cox, Matt, Marilyn a Brown, and Xiaojing Sun. 2013. "Energy Benchmarking of Commercial Buildings: A Low-Cost Pathway toward Urban Sustainability." *Environmental Research Letters* 8 (3) (September 1): 035018. doi:10.1088/1748-9326/8/3/035018. <http://stacks.iop.org/1748-9326/8/i=3/a=035018?key=crossref.91d32ac6323854cae5b985bf4390e268>.
- CTBUH. 2013. "Criteria for the Defining and Measuring of Tall Buildings."
- Energy Star. 2014a. "Energy Use Intensity (EUI)." *Energy Star*. <http://www.energystar.gov/buildings/facility-owners-and-managers/existing-buildings/use-portfolio-manager/understand-metrics/what-energy>.
- . 2014b. "The New ENERGY STAR Portfolio Manager." <http://www.energystar.gov/buildings/facility-owners-and-managers/existing-buildings/use-portfolio-manager/new-energy-star-portfolio-manager>.
- GGBP. 2013. "2013 NEW YORK CITY LOCAL LAW 84 BENCHMARKING REPORT" (September).
- IBM. 2014. "SPSS Statistics." <http://www-01.ibm.com/software/analytics/spss/products/statistics/>.
- IMT. 2014. "U.S. Benchmarking Policy Landscape." <http://www.buildingrating.org/graphic/us-benchmarking-policy-landscape>.
- Kumar, Rajesh, R K Aggarwal, and J D Sharma. 2013. "Estimation of Total Energy Load of Building Using Artificial Neural Network." *Energy and Environmental Engineering* 1 (2): 25–35. doi:10.13189/eee.2013.010201.
- MATLAB. 2014. "MATLAB." <http://www.mathworks.com/products/matlab/>.
- Milliken, Rebecca, and Betony Jones. "Office Building Benchmarking Guide Engaging the Hard-to-Reach."
- Minitab. 2013. *Getting Started with Minitab 17*.
- . 2014. "Minitab 17." <http://www.minitab.com/en-us/>.
- Monfet, Danielle, Maria Corsi, Daniel Choinière, and Elena Arkhipova. 2014. "Development of an Energy Prediction Tool for Commercial Buildings Using Case-Based Reasoning." *Energy and Buildings* 81 (October): 152–160. doi:10.1016/j.enbuild.2014.06.017. <http://linkinghub.elsevier.com/retrieve/pii/S037877881400499X>.
- NYCECC. 2011. "LOCAL LAWS OF THE CITY OF NEW YORK A LOCAL LAW". Vol. No. 1. Program, Buildings Technologies, and Energy Efficiency. 2012. "2011 Buildings Energy Data Book."
- Shan, Rudai. 2014. "Optimization for Whole Building Energy Simulation Method in Façade Design": 1–9.
- Support Minitab. 2014. "Basics of Stepwise Regression." <http://support.minitab.com/en-us/minitab/17/topic-library/modeling-statistics/regression-and-correlation/basics/basics-of-stepwise-regression/>.
- U.S. DOE. 2014. "Building Energy Codes Program." <https://www.energycodes.gov/adoption/states/new-york>.
- Yu, Zhun, Fariborz Haghghat, Benjamin C.M. Fung, and Hiroshi Yoshino. 2010. "A Decision Tree Method for Building Energy Demand Modeling." *Energy and Buildings* 42 (10) (October): 1637–1646. doi:10.1016/j.enbuild.2010.04.006. <http://linkinghub.elsevier.com/retrieve/pii/S0378778810001350>.

Morphometric method of daylight factor

Kairouan great mosque case

Sonda Kammoun¹, Abdelkader Ben Saci²

¹Equipe M2a, ED SIA, Ecole Nationale d'Architecture et d'Urbanisme, Tunis, Tunisia
²CRESSON, Ecole Nationale Supérieure d'Architecture de Grenoble, Grenoble, France

ABSTRACT: Natural light is a fundamental component of the architectural form. Understanding the interaction of natural light and building's form informs about the architectural knowledge in the field of energy efficiency and improves the building quality and performance. It is often approached either as a physical phenomenon in connection with functional aspects of comfort and needs, or as a sensory phenomenon in connection with the sensory perception of the constructed environment. We propose another way, which is to handle the natural light in architecture as a measurable morphological phenomenon.

This paper proposes a morphometric method for characterizing and measuring the daylight form. The morphometry concerns the digital simulation of the daylight factor in the great mosque of Kairouan. The selected software for daylight factor simulation is Radiance in Ecotect.

The aim of this work is to convert the sensitive into the tangible, with a view to understand how to design buildings' morphology while ensuring mastery of natural light.

Light is a measurable form. Designing with the natural light can be optimized through the analysis of its morphology.

KEYWORDS: Morphometry, Daylight Factor, Mosque's Architecture, Radiance in Ecotect.

INTRODUCTION

"Architects in planning rooms today have forgotten their faith in natural light. Depending on the touch of a finger to a switch, they are satisfied with static light and forget the endlessly changing qualities of natural light, in which a room is a different room every second of the day" (Kahn 1996, 218).

Natural light is the main topic of several architectural research projects that can be classified in three approaches. The first one considers light as a physical phenomenon and studies its performance through the simulation of the light distribution and the testing of software light simulation. In this context, Miguet (2000) offered a numerical model for the simulation of natural light in urban plan, Maamri (2004) and Namburi (2006) outlined *"an approach to compare the various most commonly used daylighting/ lighting design software programs available in the market"* and evaluated their performances *"based upon their capabilities to fulfill the assigned tasks by the users/lighting designers"*.

The second studies the integration of daylighting in design process. Tourre (2007) suggested a method which concretizes lighting ambience intentions, by producing geometrical properties of openings. *"The designer is allowed to express his lighting ambience intentions through physical lighting parameters"* (Tourre 2007, VII). More recent studies propose a design support method that takes into account *"the early design step features and helps designers to integrate their daylight atmosphere intentions in project"* (Gallas 2013).

The third implied that light is considered to be a sensitive phenomenon in relation with the perception of the built environment (Chelkoff 1990, Milone 2007, Michael 2012). Some researchers were interested in the space perception through the evaluation of comfort such as Dubois who shows that the diversity of luminous ambiances, produced by the integration of natural lighting in the internal areas, is capable of creating comfortable areas (2006).

In the current context of sustainable development, this work proposes another way that considers natural light in architecture as a measurable morphological phenomenon. In this paper, we offer to assess the daylight in the great mosque of Kairouan through a morphometric approach in order to characterize the space distribution of natural light in correlation with the built space.

The objective is to develop a method to measure the form of natural light based on the morphometric analysis and the computer simulation of the daylight factor (DF). In a more general way, the aim is to convert the sensitive into tangible, in a perspective to design buildings morphology while ensuring mastery of natural light.

1.0 MATERIAL AND METHOD

1.1. Presentation of the case study

"I am, one more time, in the great Mosque of Kairouan, in the centre of this huge courtyard bathing in natural light. Deep thinking makes me abolish the tiles which regularly cover the ground, the minaret which points up to the sky, the prayer hall which looks out over it and the porticos which attain the horizon" (Sebag 1977).¹

We are proposing to study the case of the great mosque of Kairouan, the oldest and most prestigious place of worship in North Africa (Gabrieli). The mosque of Uqba or great mosque is located in the Nord-East of the fortified surrounding wall of the Medina of Kairouan (Fig. 1).



Figure 1: Aerial view of Kairouan Great Mosque or Mosque of Uqba in Tunisia. Source : (Filkr, Momin Bannani 2014).

Established in 670 by Oqba Ibn Nafeu at the founding of Kairouan, the mosque was destroyed about 690 by the Berbers. It was rebuilt, renovated and expanded by Arab governors Hassan Ben Noman (703) and Bichr Ibn Safouan (724) (Saladin, 1899). It acquired its essential features under the Aghlabides (9th century) with Ziadet Allah 1st who reconstructed the mosque once more (836).

The Kairouan great mosque looks like a fortress with their 2m thick exterior walls. The building is a large irregular quadrilateral. Its dimensions are approximately 135 m by 75 m. It covers a total area of 9000 m².

The hypostyle prayer hall takes a rectangular shape divided into seventeen naves of eight bays (Fig. 2). It counts about 400 columns reused from Roman. The Mihrab is located in the middle of the southern wall and covered by the dome based on an octagonal drum with slightly concave sides, pierced by eight windows based on a square base. The courtyard and the galleries that surround cover an immense area with a length of about 90 meters and 72 meters in width (Fig. 3).



Figure 2: Interior view of the prayer hall of the Kairouan mosque. Source: (Author 2013)



Figure 3: Interior view of the galleries. Source: (Author 2013)

1.2. Method

We chose the Daylight Factor (DF) as an analyzing natural light indicator in the mosque. This notion allows to assess the relationship between internal illumination and the availability of the natural light. It is defined by the International Committee of Lighting (CIE) as a ratio that represents the amount of illumination available indoors, related to the outdoor existing illumination at the same time. Expressed in percentage, the DF should be calculated under the CIE overcast sky condition.

The daylight simulation was performed using Radiance in Ecotect Analysis. According to Marsh, Radiance is:

“Currently the most accurate tool available for both daylighting and artificial lighting analysis. It uses a two-pass, hybrid, backwards-raytracing algorithm that can handle complex geometry and sophisticated material definitions. Moreover, it is one of only a few analysis tools that can calculate illuminance levels”. [Marsh 2007]

We also performed tests using several software (3Ds Max Design, Daysim, Ecotect, solene), we considered a case study, and we compared between the experimental measurements taken on-site with tow luxmeters and the simulation results. The Radiance software in Ecotect gave the closest results to experimental measures that joins Marsh conclusion.

We then proposed to study the form of the natural light distribution through a morphometric approach. The morphometry is a tool that allows to measure form and to clear its invisible structure. It is an *operation of spatial forms conversion into quantitative representations* (Ben Saci, 2000).

The objective of the morphometric analysis is to understand forms, defined in epistemological terms, by an objective understanding of forms and, in pragmatic terms, by a systematic characterisation tool of morphological information allowing to compare and to categorise forms, and to disclose invisible morphological structures from visible forms (Ben saci, 2000).

Morphometric calculation is performed by Morgine software, developed as part of doctoral research projects directed by Ben Saci. It characterises forms by a descriptor representing an information distributing profile of DF in the mosque.

1.3. Application of the method

The first step is the realisation of the Kairouan great mosque numerical model by using surface modelling, designed in 3Ds Max Design (version 2010). This model was accomplished by setting up a methodology to ensure perfection and realism that could guarantee a better quality and accuracy of subsequent calculations. In fact, we collected and rectified drawing plan and facades in situ, and we took photos of each detail to create the 3D model (Fig. 4).

We chose to assimilate openings with holes, it is about the case of maximum penetration of natural light in the mosque (Fig. 5).

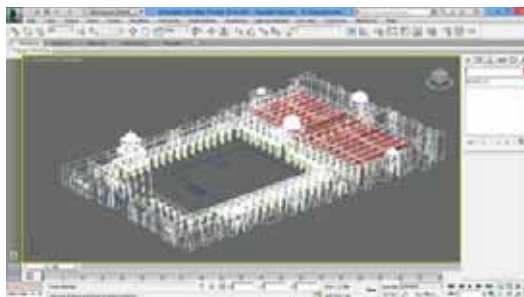

Figure 4: 3D model of the great mosque of Kairouan under 3Ds Max Design 2010. (Auteur, 2014)



Figure 5: 3D view of the great mosque of Kairouan model. Source: (Auteur 2014)

We then imported the 3D model under DXF format in software Ecotect Analysis; we specified the scale of the drawing, the materials of objects and the characteristics of the site (latitude, longitude and North position).

We specified the grid of sensor points for analysis by specifying its size and cell number. We have chosen 3 meter as a distance between points, since the greater the number of cells the greater the accuracy of the grid calculation, but the longer it will take (Table 1).

Table 1: Definition of the analysis grid dimension sunder Ecotect. Source: (Author 2014)

Mosque dimensions			Number of cells	
width	length	height	X axis	Y axis
82m	133m	14m	28	45

We exported the model with the analysis grid to radiance. Simulation was performed in the case of a CIE overcast sky, materials were defined according to the database of Ecotect and an indirect reflections value of 5 (Fig. 6).



Figure 6: Ecotect software interface when exporting to radiance analysis. Source: (Author 2014)

The simulation results are represented by a DF cartography and a table of values exported in CSV format.

Then we performed a morphometric calculation by Morgine software, following these steps:

- Importing the values table in CSV format under Morgine;
- Calculating descriptors (Fig. 7);
- Exporting results in a CSV file, exploitable under Excel.
- Generating curve which translates the analyzed object morphometry.

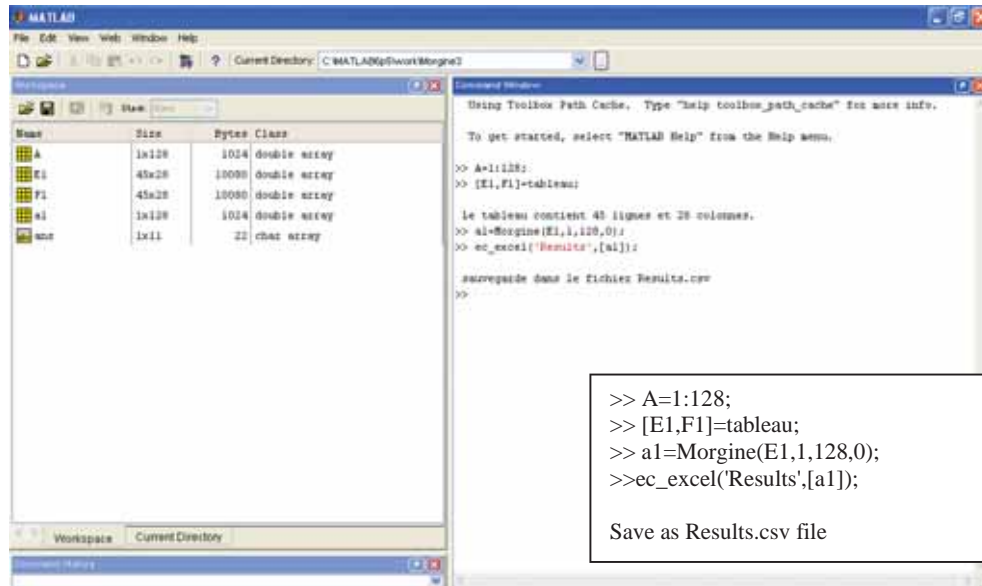

Figure 7: Morgine under the Matlab interface. Source: (Author 2014)

2.0 RESULTS

2.1. DF cartography

The first simulation performed by DF gives us the following results:

- The average daylight factor value of the Kairouan great mosque is 42.54%.
- *For the prayer hall*, we recorded 1.7% as an average daylight factor. The values range from 0 to 6.13%, corresponding to Lux values varying between 0 and 49 Lux. Therefore, middle and low values correspond to the needs of light in a worship place, but we should bear in mind that we chose a case of daylight maximal penetration (all openings are assimilated with holes). The highest values are recorded in the first bay from the gallery side. These values decrease by getting closer to the Qibla wall. The lowest DF value is recorded inside the Mihrab. The distribution of light inside the prayer hall is uniform and corresponds to the division accomplished by naves and bays (Fig. 8 and Fig. 9)
- *For the gallery*, we recorded an average of 13.21%, values vary between 0 and 51%. Light is deeper in the western gallery than the eastern one. This can be explained by the presence of the lateral and transverse arcades in the eastern gallery, formed by a double row of parallel arcades opened into the courtyard.

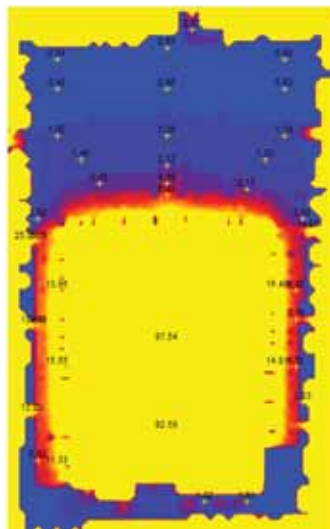

Figure 8: DF Cartography of the Kairouan great mosque. Source: (Author 2014)

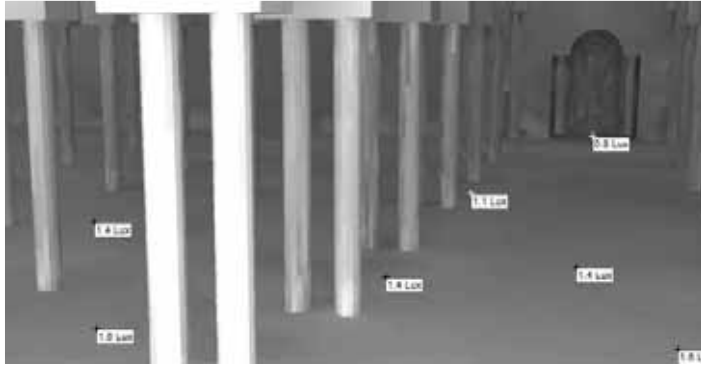

Figure 9: Illuminance radiance simulation. Source: (Author 2014)

2.2. Form of the DF distribution

To study the form of the DF distribution in the Kairouan great mosque, we applied morphometric steps:

- Exporting the analysis grid with DF values in CSV format (figure10), forming a table, which is in this case made by 45 lines and 28 columns ;
- Generating a morphometric transcription picture (Fig. 11) ;
- Creating a frequency curve of the DF distribution form (Fig. 12).

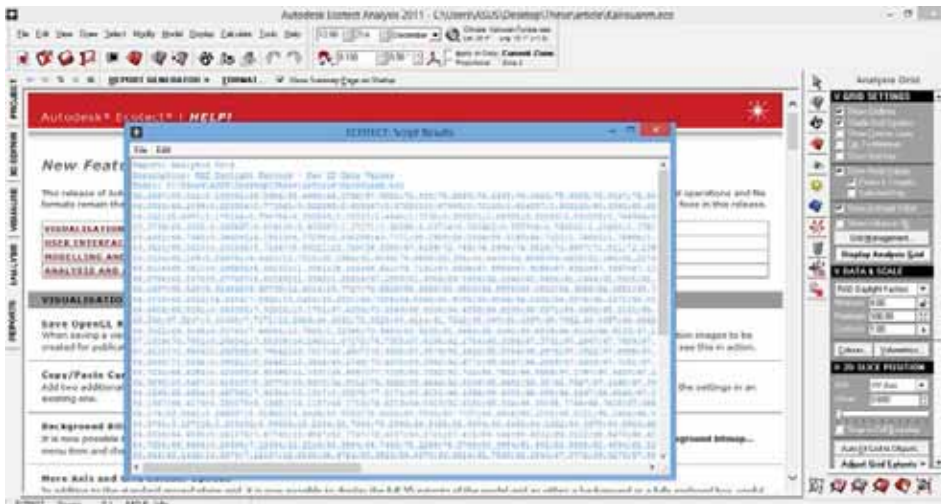

Figure 10: Table of values exportation in CSV format. Source: (Author 2014)

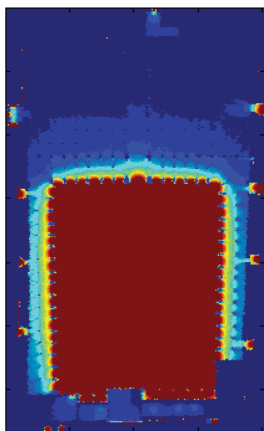

Figure 11: Morphometric transcription picture. Source: (Author 2014)

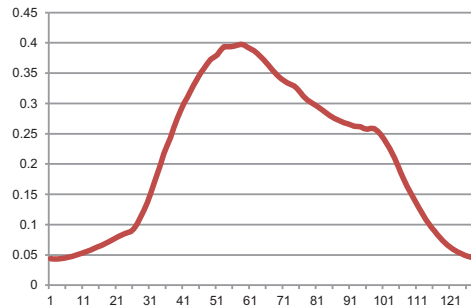

Figure 12: Curve of the DF morphometric distribution. Source: (Author 2014)

The curve has a peak which corresponds to the courtyard. It is the main source of natural light distribution inside the prayer hall and the gallery. The amplitude of the curve is directly linked to the proportions of this courtyard.

CONCLUSION

This paper describes a scientific method for measuring natural light distribution inside constructed buildings. We explained different steps of Morphometric method of the daylight factor through the case of the Kairouan great mosque.

Obtained results confirm that natural light can be considered as a measurable morphological phenomenon. Thus, combining the numerical daylight simulation and the morphometric analyses allows the transformation of sensitive into tangible.

This work shows that the spread of natural light in Kairouan great mosque is directly linked to its form, particularly the form of the courtyard and the galleries that surround it; and that getting closer to the Qibla wall, decreases the amount of natural light. Light is an important element in the conception of mosques.

The results of this simulation inform about the architectural built heritage and contribute to the knowledge of the logic behind the field of morphology correlated with daylight. We plan to apply this approach on a larger corpus formed by Maghreb great mosque with a view to understanding the logic of sustainable development from a built heritage.

REFERENCES

- Saci, Ben A. 2000. Identification des formes, intervention lors du Séminaire : *Concevoir et faire le projet en architecture : analyser, expérimenter et enseigner*, Tunisia.
- Bodart, M. 2002. Création d'un outil d'aide aux choix optimisé du vitrage du bâtiment selon des critères physiques économiques et écologiques pour un meilleur confort visuel et thermique. Thesis UCL.
- Cauwerts, C. 2013. Influence of presentation modes on visual perceptions of daylight spaces. Thesis UCL.
- Dubois, C. 2006. Confort et diversité des ambiances lumineuses en architecture, l'influence de l'éclairage naturel sur les occupants. Thesis GRAP Laval.
- Gabrieli, F., *Maghreb Médiéval, l'apogée de la civilisation islamique dans l'occident arabe*, Edisud.
- Gallas, Ma. 2013. *De l'intention à la solution architecturale, proposition d'une méthode d'assistance à la prise en compte de la lumière naturelle durant les phases amont de conception*. Thesis Loorraine University.
- Marsh J. A. 2007. Radiance and Daylight Factors in Natural Frequency Journal, N°4.
- Saladin H., *La mosquée de Sidi Okba à Kairouan*, Ernest Le Roux, Paris, 1899.
- Sebag P., *La grande mosquée de Kairouan*, collection Nouvel Observateur, Delpire, 1977.
- "Momin Bannani Photos", last modified September, 2014, <http://www.flickr.com/photos/mominbannani>.

ⁱThe original text in french : "Je me trouve, une fois de plus, dans la Grande Mosquée de Kairouan, au centre de cette immense cour inondée de lumière. Par la pensée, j'abolis les dalles qui recouvrent régulièrement le sol, le minaret qui s'élançait vers le ciel, la salle de prières qui lui fait face et les portiques qui achèvent de fermer l'horizon".

Negative life-cycle emissions growth rate through retrofit of existing institutional buildings

Somayah Tabatabaee¹, Benjamin S. Weil¹, Ajla Aksamija¹

¹University of Massachusetts, Amherst, MA

ABSTRACT: Buildings account for about one fifth of the world's total delivered energy use, and thus methods for reducing energy consumption and carbon emission associated with buildings are crucial elements for climate change mitigation and sustainability. Voluntary challenges, mandates, and, particularly, public institutions have articulated these goals in terms of striving for "net-zero energy" buildings, and mandated measurable reductions in greenhouse gas emissions. Typically, the definition of net-zero and other energy consumption reduction goals only consider operational energy. By ignoring embodied energy during the entire life-cycle of the building (manufacture, use and demolition of materials and systems), such goals and mandates may drive suboptimal decisions in terms of cost-effective greenhouse gas emission reductions. Many new buildings will require decades of net-zero operational energy consumption to negate climate change and other environmental impacts during the construction process. Additionally, if a new building is part of a portfolio of institutional buildings, even with net-zero energy consumption, the most optimistic scenario is the eventual reduction of emission growth rate to zero. A more productive approach for reducing the life-cycle energy in a building and associated negative environmental impacts may be to focus on retrofitting existing buildings. However, since large investments in existing building stock can be difficult to justify and approve in an institutional context, fixed portions of life-cycle costs also highlight the importance of maximizing the operational energy impact associated with any renovation. This study uses life-cycle analysis to evaluate efficacy of energy retrofits for an existing institutional building located on the University of Massachusetts Amherst campus. Using data, energy models, and life-cycle analysis tools for an actual energy retrofit on an existing residential building, this study will show how poor controls and failing to address thermal bridges can affect our model expectations. By developing a process for life cycle based evaluating retrofit options this study will explore the implication of producing an institution-wide negative net-energy growth rate.

KEYWORDS: Net-zero, Life-cycle, Retrofit, Institutional, Emissions Growth Rate

INTRODUCTION

Buildings are responsible for about one fifth of total delivered energy of the world, which is required for their operation (U.S. Energy Information Administration 2010). Life-cycle energy of a building includes the construction, operation, and decommissioning phases of a building's existence (Dixit and Fernandez-Solis 2010). Embodied energy (EE) in building materials has sequestered from the whole stages of production, construction, and demolition and disposal, while operating energy (OE) is consumed for maintaining interior environmental, including cooling, heating, operating appliances, and lighting (Ding 2004).

A leading tool for evaluating all sources and types of environmental impact is life-cycle assessment (LCA). This strategy has been determined by the International Organization of Standardization (ISO) 14040-14044 standards (Sodagar 2013). LCA aims to combine total energy inputs for a building into the whole life-cycle energy consumption, and analyzes the energy use of all stages from manufacture, use, and demolition (Sesana and Salvalai 2013). LCA study is a valuable method that should be completed on all projects to consider possible benefits of energy cost savings, carbon emission reductions and other environmental benefits (Buys, Bendewald, and Tupper 2011).

Most nations have instituted regulations to ensure reduced energy use in buildings. For example, all buildings built in the European Union should achieve nearly zero levels in energy use after 2020 under Recast Directive of the energy performance in buildings (EPBD), published by European Union (EU) in 2002 (Sesana and Salvalai 2013). This guidance makes a commitment to a very high level of energy performance in all new buildings in less than one decade, and the energy will predominantly come from renewable energy sources (Sesana and Salvalai 2013).

While directives to achieve net zero energy can significantly reduce energy demands in new buildings, most regulations related to 'net-zero' only consider energy in operation and ignore the embodied energy (Hernandez and Kenny 2010). A summary of 73 buildings in 13 countries in the life-cycle energy analyses that includes office and residential buildings, concluded that 80-90% of energy use is for operation, while 10-20% is the embodied energy (Ramesha and Prakasha 2010). To account for the total energy impact of buildings, life-cycle aspects should be considered in global perspectives. The definition of life-cycle zero

energy buildings (LC-ZEB) proposed by Hernandez and Kenny (2010) provides a useful framework for total building energy use, which includes embodied energy and shows attempt to develop regulations and policies on Life Cycle Zero Energy approaches. Typically, due to the relative energy inefficiency of new buildings, OE has been much larger than EE, even after just a few years of operation. However, as buildings are designed to consume less energy, the relative importance of EE is likely to increase.

Although there are several factors, such as cultural and economic values, that weigh into decision of whether to rehabilitate buildings or demolish and rebuild, environmental factors can be a compelling reason in favor of building conservation. Embodied energy saved in existing building structures is one of the main environmental benefits of building reuse, which aims to reduce greenhouse gas emissions (Preservation Green Lab, 2011). It will take decades for a new net zero energy building to overcome negative environmental impacts resulting from new construction including global warming potential, acidification, fossil fuel consumption and ozone depletion (Radermacher 2011). For most building types (excluding warehouses and multifamily residential buildings), it will take 10 to 80 years for a new construction, with 30% higher efficiency from average performance codes to negate, through efficient operations, the overall impacts of new construction (Preservation Green Lab, 2011). Therefore a potentially more efficacious approach for achieving energy efficiency that offers immediate climate-change reductions is to focus on retrofitting existing buildings (Radermacher 2011). To get the most significant emissions reductions, reuse and retrofitting for energy efficiency must work together. Construction materials selected during retrofit are also critical to minimize environmental impacts of reuse, since the type and quantity of materials selected during this process can reduce or negate the benefits of retrofit (Preservation Green Lab, 2011). Because most existing buildings were not constructed and designed for net-zero-energy performance, they present challenges to retrofits intended to bring operational energy to near zero (Radermacher 2011). Arden et al. (2011) showed that the most significant environmental and energy benefits during retrofit come from improvement in thermal insulation envelope, such as replacing windows, improving insulation, and reducing infiltration. Additional major energy benefits come from renovating HVAC and lighting systems (Arden et al. 2011).

Therefore, this research uses a case study building at the University of Massachusetts Amherst (UMass Amherst) to conduct a detailed analysis of building reuse and retrofit as part of a strategy to reduce overall campus energy consumption.

1.0 BACKGROUND AND OBJECTIVES

In August 2013, University of Massachusetts Amherst completed the second phase renovation of Grayson Hall Dormitory, which was started in March 2012 and was conducted in two summers while resident halls were closed. Grayson Hall, which was built in 1965, is one of the four similar buildings located in Orchard Hill Residential Area. The campus central combined heat and power (CHP) plant uses primarily natural gas to produce steam, which provides heat and hot water in this dormitory. The original Grayson envelope and exterior walls did not have thermal insulation and consisted of brick veneer, back up concrete masonry unit (CMU), and aluminum frame single glazed windows (Mostafavi 2013). UMass Amherst retrofit plan requires that all deteriorated brick facades are removed and single aluminum window panels are replaced with new double pane aluminum windows, which was done for the Grayson Hall. Also, 2 inches of polystyrene rigid insulation were added between the CMU walls and the new brick façade.

Despite this investment, a study of actual energy performance of the building in FY 2014 showed no difference in heating loads and steam consumption after renovation. Indeed, steam consumption actually increased, and Table 1 shows total and weather-normalized data (Table 1).

Table 1: Grayson Hall building actual steam consumption.

Steam lb	Jul	Aug	Sep	Oct	Nov	Dec	Jan
FY10	56,796	-	272,350	492,042	527,979	760,727	716,825
FY11	138,606	166,010	208,215	372,627	512,418	681,235	817,953
FY12	190,229	189,655	195,902	393,423	401,939	573,850	650,362
FY14	182,108	188,301	186,022	300,388	495,793	578,354	622,728

Steam lb	Feb	Mar	Apr	May	Jun	Total	Weather Normalized
FY10	630,876	468,418	366,924	256,897	165,729	4,715,565	3,422,023
FY11	695,724	613,209	409,956	239,494	185,431	5,040,878	3,911,707
FY12	593,219	517,380	378,607	223,143	185,940	4,493,648	3,683,558
FY14	572,577	637,013	390,916	213,572	184,158	4,551,931	4,037,648

Building energy model, which was calibrated to pre-retrofit actual energy usage, predicted heating energy reduction of 26% (Mostafavi 2013). This project uses that calibrated model to explore an alternative retrofit path, so it is important to explain the divergence between the predicted and actual energy use.

2.0 ENERGY ANALYSIS

Based on simple degree-day analysis of building performance we hypothesized that divergence from model predictions were likely explained by changes in building operations and by inaccuracies in the model itself.

2.1. Building Operation

Like many buildings on campus, there are no room thermostats. Instead, the hydronic heating temperature is controlled using outdoor temperature reset. The building operator calculates a heat loss rate at two outdoor temperatures (often a design temperature and the balance point temperature), and determines the water temperature required to offset that heat loss. The line between these two points determines the outdoor reset curve. In the case of Grayson Hall, prior to retrofit work, hot water was set to 180°F at a design outside temperature of 0°F. After insulation was added to the walls and the windows were upgraded, the heat loss rate would have declined, however the outdoor reset curve was never adjusted to the new condition. In fact, interior temperatures recorded by the University’s Energy Engineer show an average interior temperature increase of about 3°, which would be consistent with higher water temperatures and lower heat loss factor. The higher temperatures most likely led to overheating and occupants may have opened their windows more frequently to cool rooms down. The change in window opening behavior is not quantified, but as we can see in Figure 1, which was captured in 25°F outdoor conditions, most of the windows are open.

Table 2: Grayson Hall building average inside temperature.

Start Date	End Date	Average Temperature /Inside
12/1/2011	1/31/2012	69.4 °F
12/1/2013	1/31/2014	72.6 °F



Figure 1: Grayson Hall west façade open windows.



Figure 2: Thermal bridges with exposed concrete.

2.2. eQuest model inputs and energy runs

The baseline model was calibrated with average energy use from FY2010-2012. The model was modified (Mostafavi 2013) to account for the addition of R-6 Polystyrene insulation to the wall assembly and the thermally broken aluminum double pane windows with insulated lower panels. This resulted in predicted savings of 26% in the eQuest model. In reality, however, the building renovation only involved adding insulation to the in-fill panels of the brick façade between windows, leaving the concrete structure exposed and providing significant thermal bridging (Figure 2). This is indicative of a shortcoming in the capabilities of eQuest as a modeling interface, since only one wall assembly can be specified for each story. In this case, it was necessary to perform a simple two dimensional area-weighted parallel path heat loss calculation to find the “effective” whole wall R-value using standard R-values for the relevant materials (ASHRAE 2013). When concrete thermal bridges are accounted for, the effective R value of the renovated façade is just 0.6 ft² °F hr/Btu higher than the pre-retrofit baseline R value of 2.0 (ft² °F hr/Btu) (Table 3).

Table 3: Effective values for thermal performance of exterior walls.

Effective Values	U Factor (BTU/hr/ft ² /°F)	R Value (ft ² °F hr/Btu)
Before Renovation	0.49	2.03
After Renovation	0.38	2.62

Using the effective R value of 2.6 ft² °Fhr/Btu in the existing eQuest Model with the software calculation of balance point temperature and same internal loads resulted in a 9% reduction in thermal energy consumption and 18% reduction in heat loads. When the same model was run with a 3°F increase in temperature set points the result was energy consumption and heat loads nearly the same as the baseline model. This neatly recapitulates what occurred in reality, suggesting the validity of the above R-value calculation and the observation relating to outdoor temperature hydronic reset control settings.

Figure 3 shows the numbers and differences between Baseline Energy Consumption, Real Retrofit considering true R value, and the Actual Performance Run with 3°F increase set points in the eQuest model. We concluded that the difference in the set point temperatures and the effective heat transfer coefficient of the exterior walls are the reasons for discrepancy between the modeled and actual energy usage. Therefore not only the poor control was considerable in this case, also failing to address thermal bridges which was not reflected in the software menu made error in our energy level expectation of the building after renovation.

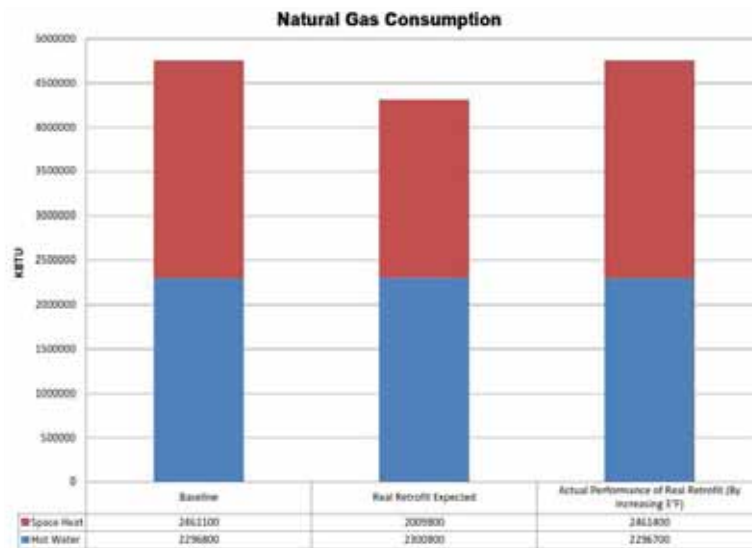

Figure 3: Current retrofit energy runs.

2.3. Alternative Renovation

Given the paltry performance of the actual retrofit, we propose an alternative, which covers the surface of the façade to eliminate thermal bridging and provides for a deliberately constructed continuous air barrier. The proposed method has been demonstrated on low-rise buildings and has proven to be buildable and effective wall insulation retrofit method, which can support the addition of 6 inch continuous insulation with R value of 30 ft²-°F-hr/Btu (Lstiburek 2014). The method, described in Lstiburek (2014) provides for a continuous fluid-applied air and water barrier to coat the existing brick and concrete exterior. Dimensional 2x4 Wood or Metal studs are mechanically attached to the existing surface, spaced such that 1.5 inch rigid insulation can be placed between the studs, then rigid insulation is applied over the entire assembly with joints staggered and offset. We considered a total of 6 inches of rigid insulation. Vertical strapping provides an air gap and drainage plane behind the cladding as well as attachment surface for new cladding, which can be a light material like fibre cement-based composite panel. Figure 4 shows a section of this approach.

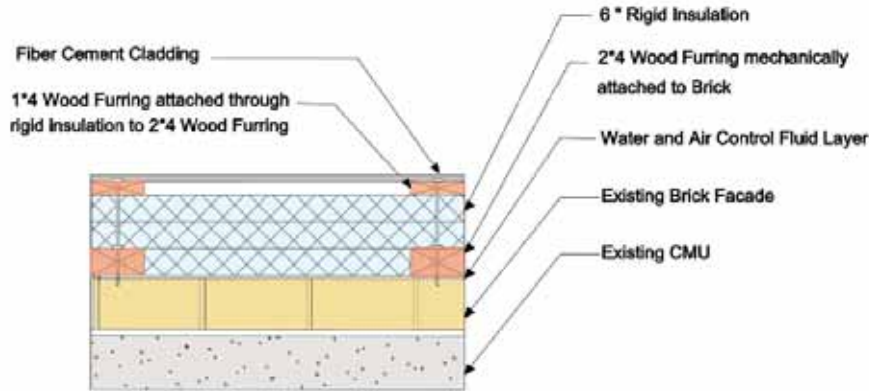

Figure 4: New recommendation for façade.

This total wall assembly with R value of 36 ft²-°F-hr/Btu was specified in the eQuest model. The air leakage rate was modified to 0.038 CFM/sft ACH to reflect the deliberate air barrier fabrication approach. Figures 5 and 6 show the energy performance runs of this new alternative vs. real and baseline runs, and predicts 34% saving in total heating energy consumption compared to the baseline, and 64% savings over the heat loads of baseline before renovation. This new alternative shows considerable saving in energy performance of the building while we have not a very huge difference in cost.

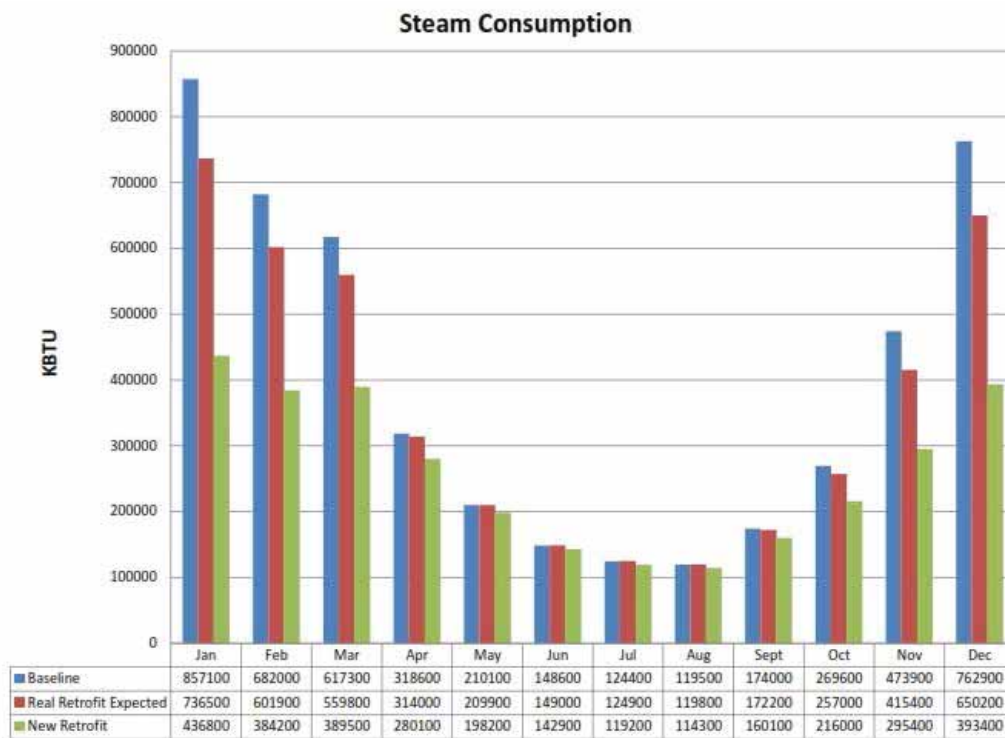

Figure 5: Monthly comparison graph between total heating energy consumption of real retrofit vs. new ideal alternative.

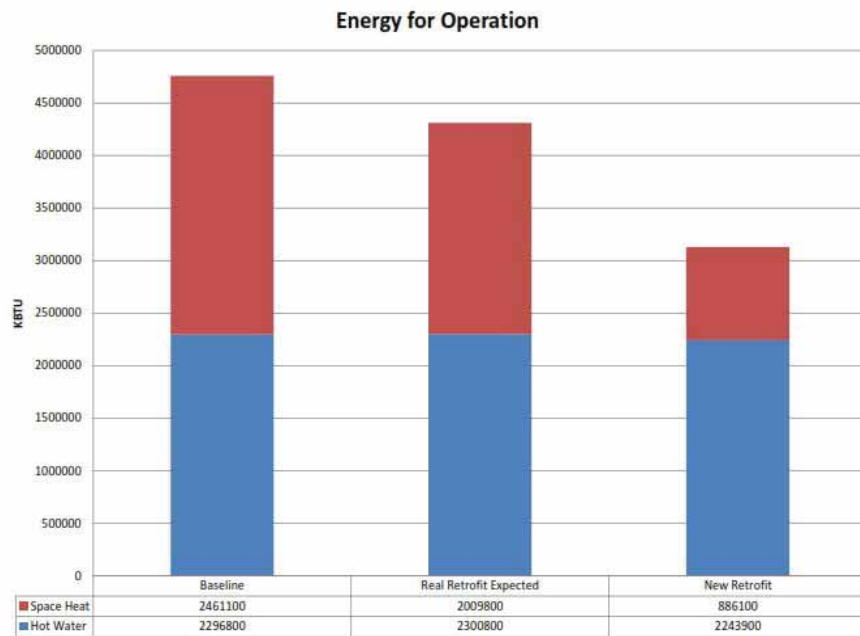

Figure 6: Total heating energy consumption comparison.

3.0 LCA ANALYSIS

3.1. LCA analysis method

This study was conducted using the ATHENA Impact Estimator, which is an environmental life-cycle assessment tool. This tool provides a cradle-to-grave assessment for buildings. The measurements are using US EPA analysis methods for assessment and reduction of environmental impacts. Also, this software uses the standard method for calculating life-cycle assessment, based on International Organization of Standardization (ISO) 21930/31. The outputs measure whole environmental impacts of buildings, including manufacturing, transportation, construction, energy use, building type and lifespan, maintenance, and demolition and disposal. The outputs can be divided into several categories: Global Warming Potential (CO₂ equivalent mass), Human Health Criteria (PM 2.5 equivalent mass), Acidification (Air) Potential (SO₂ equivalent mass), Smog (air) Potential (O₃ equivalent mass), Eutrophication (air & water) Potential (N equivalent mass), Fossil Fuel Consumption (GJ Total fossil fuel energy), and Ozone Depletion (air) Potential (CFC 11 equivalent), seen in Figure 7.

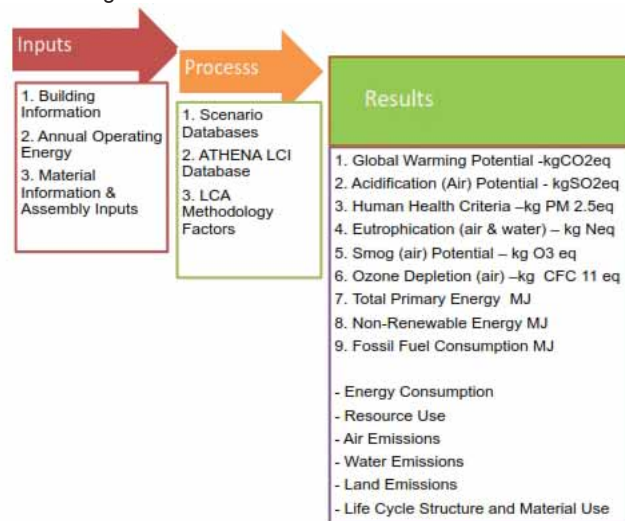

Figure 7: ATHENA Impact Estimator LCA conceptual model.

3.2. Grayson Hall retrofit LCA

In this study, the LCA for real retrofit Grayson Hall Building was conducted to investigate emissions and impacts through the process of renovation over the life expectancy of 50 years. Since this retrofit was done after 50 years of building's life, we are expecting an average of 50 years for building's life performance before next decision. By importing the building information, annual operating energy and renovation materials to ATHENA and adding the impact of demolition materials from deteriorated existing brick façade and windows, the LCA of this renovation was conducted over the life span of 50 years. Table 4 shows building information, energy inputs, and the type and quantity of materials used in ATHENA. Operating energy was considered with 9% savings over the pre-retrofit baseline, as we assume the thermostat set points are adjusted and building is operating as low as model expectation.

Table 4: LCA inputs.

Inputs	Real Retrofit	Ideal Retrofit
Project Location		New York City
Building Type		Multi Unit Residential- Rental
Building Life Expectancy		50 Years
Building Height		61.8 ft
Gross Floor Area		78214 sqft
Operating Description		370123.0 KWh
Custom Wall	117067.7 m3 Natural Gas (4,310.6 MBtu)	84.317.8 m3 Natural Gas (3,104.7 MBtu)
Windows	–	Wood Stud, Non loading, None Sheathing, 24 o.c., Stud 2*4, Kiln-dried
Doors		Number of Windows: 477
Envelope		Frame Type: Aluminum Window Frame Double Pane Total Window Area: 13679.5 sf Glazing Type: Double Glazed Hard Coated Air
Extra Materials	Brick- Modular (metric)	Number of Doors: 17 Door Type: Aluminum Exterior Door, 80% glazing Polystyrene Extruded (6 inch) Air Barrier
Demolition Materials From Existing Façade		Fiber Cement Siding Aluminum 1.2 (ton) Extruded Polystyrene 2,336 sf Concrete 3.9 yd3 Small Dimension Softwood Lumber
		Aluminum Window Frame: 15,274.99 lbs Glazing Panel: 20.67 ton(short)
	Metric Modular Brick: 9,691.428 sf	

The final results and total impacts are shown in *Logarithmic Scale* graph, considering material and energy consumption impact of the whole life cycle of current renovation over next 50 years (Figure 8). In this chart the total energy consumption of the renovated building was taken into account to get the real impact of building over its life.

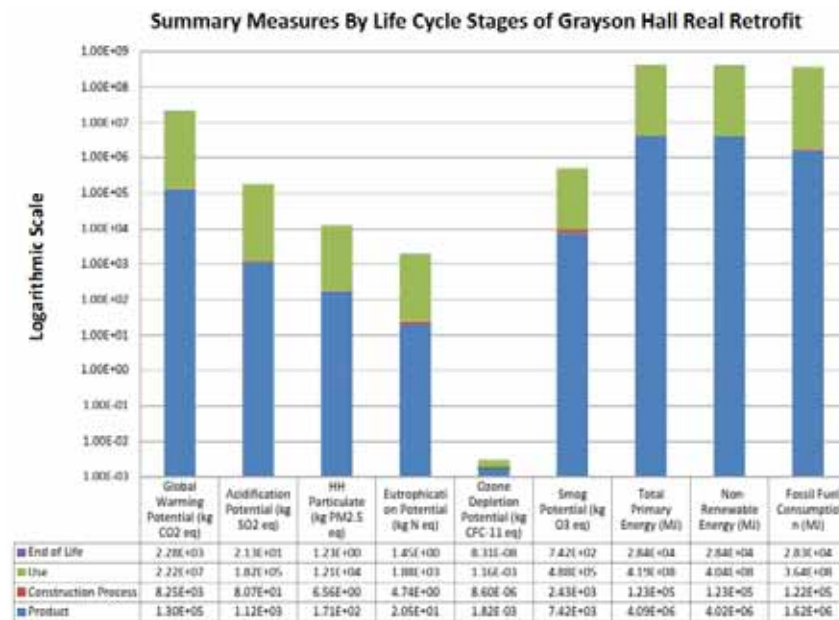

Figure 8: Life-cycle impacts of the Grayson Hall renovation.

The renovation materials from ideal alternative, energy inputs, and demolition elements (Table 4) were also imported to ATHENA Impact Estimator to get the summary of Environmental Impacts. In this case, the wall assembly and extra materials were different, and energy for operation and demolition materials from existing façade was lower. The only element removed and demolished from existing façade was single pane aluminum windows. Table 5 shows the final reports comparing LCA impact of this ideal retrofit with total steam saving of 34% with Real Retrofit of %9 reductions in total heating loads.

Table 5: Life cycle impact of real retrofit vs. ideal renovation.

		Real Renovation	Ideal Renovation
Global Warming Potential	kg CO2 eq	2.23E+07	1.83E+07
Acidification Potential	kg SO2 eq	1.83E+05	1.49E+05
HH Particulate	kg PM2.5 eq	1.23E+04	1.03E+04
Eutrophication Potential	kg N eq	1.91E+03	1.59E+03
Ozone Depletion Potential	kg CFC-11 eq	2.99E-03	2.99E-03
Smog Potential	kg O3 eq	4.98E+05	4.13E+05
Total Primary Energy	MJ	4.23E+08	3.55E+08
Non-Renewable Energy	MJ	4.08E+08	3.40E+08
Fossil Fuel Consumption	MJ	3.66E+08	2.97E+08

Also, another analysis was conducted to compare emissions produced by materials during renovation process and emission reductions related to the energy savings of real retrofit *ideally* when the set points have been adjusted. Figure 9 shows that the emission reductions would be higher than emission produced during the renovation process, indicating that renovation of existing buildings is indeed a preferable method for reducing carbon emissions associated with buildings.

Emission Produced by Renovation Materials Vs. Emission Reduced by Energy Saving

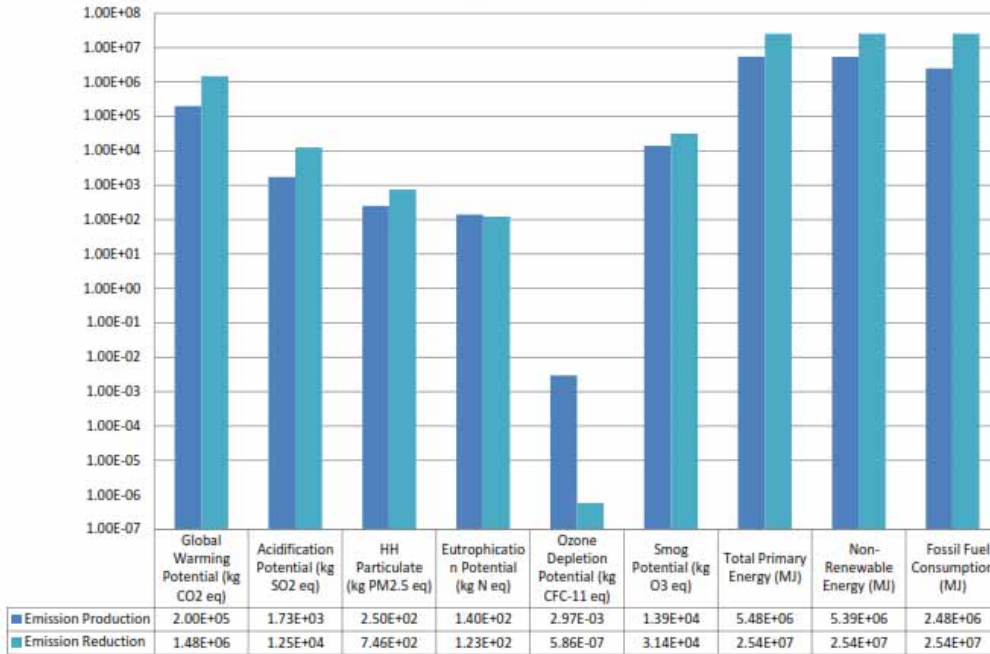

Figure 9: Comparison between produced and reduced emission through the process of Grayson Hall renovation.

CONCLUSION

This project has several outputs. First, it shows how thermal bridges have a significant effect on thermal performance of the building. In this case, thermal bridges in the exterior walls resulted in significant deviations from predicted energy use, while model expectations were based on just software menu and was not reflected this thermal exposure of façade elements. Therefore, we investigated a method for reducing thermal bridges and providing high thermal performance for façade by not a huge difference in cost. With improved building envelope, we showed that it is possible to achieve 34% reduction of gas consumption and 64% savings for heating loads. So this study will show clearly the importance of considering effective R value in thermal performance of the façade in a renovation process.

Next outcome from this study relates to the life-cycle impact of the renovation. We compared the total life-cycle energy of two retrofit approaches over life cycle of 50 years. Also, total environmental impact associated with renovation materials were compared by real reduced impact from energy savings. The results show that for almost all categories of environmental impacts this reduction in operational energy would be higher than emissions produced by renovation through the life-cycle of the building. Also in future study this result will be compared based on per square footage with a new LEED Dormitory of Commonwealth Honors College to know whether reuse of a degraded building have lifetime carbon emissions and other environmental and financial impacts greater than or lower than a new construction. Life cycle cost of the project will be studied in future research.

The advantage of this study can be used in other three dormitories of Orchard Hill Residential Area which have the same geometry and renovation process as Grayson Hall Building. This process and results may also affect future retrofit policies at UMass Amherst and other higher education institutions, and provide clear understanding of environmental benefit for adaptive reuse and retrofit of existing buildings.

REFERENCES

Ardente, F., M. Beccali, M. Cellura, and M. Mistretta. 2011. *Energy and environmental benefits in public buildings as a result of retrofit actions*. Renewable and Sustainable Energy Reviews 15:460-470.

ATHENA Sustainable Materials Institute, 2013. *Life Cycle Assessment Software of Impact Estimator 2013*. <<http://calculatelca.com/software/impact-estimator/>>

Buys, A., M. Bendewald, and K. Tupper. 2011. *Life cycle cost analysis: Is it worth the effort?* Pages 541-548 in Life cycle cost analysis: Is it worth the effort? ASHRAE Winter Conference, January 29, 2011 - February 2. American Society of Heating, Refrigerating, and Air-Conditioning Eng. Inc.

- Ding, G., 2004. *The development of a multi-criteria approach for the measurement of sustainable performance for built projects and facilities*, Ph.D. Thesis, University of technology, Sydney, Australia.
- Dixit, M. K., J. Fernandez-Solis, S. Lavy, and C. H. Culp. 2010. *Identification of parameters for embodied energy measurement: A literature review*. Energy and Buildings 42:1238-1247.
- Hernandez, P., and P. Kenny. 2010. *From net energy to zero energy buildings: Defining life cycle zero energy buildings (LC-ZEB)*. Energy and Buildings 42:815-821.
- Hernandez, P., and P. Kenny. 2011. *Development of a methodology for life cycle building energy ratings*. Energy Policy 39:3779-3788.
- Lstiburek, J.N. 2014, *Building Sciences: Deep-Dish Retrofits* ASHRAE Journal, vol. 56, no. 8: 38-45
- Mostafavi, N., and Farzinmoghadam, M., and Hoque, S. 2013. *Envelope retrofit analysis using eQuest, IESVE Revit Plug-in and Green Building Studio: a university dormitory case study*. International Journal of Sustainable Energy
- NIST Engineering Laboratory, 2013. *BEES Building Environmental and Economic Sustainability Online software 2010*. <<http://www.nist.gov/el/economics/BEESSoftware.cfm>>
- Preservation Green Lab. 2011. *The Greenest Building: Quantifying the Environmental Value of Building Reuse*
- Radermacher, R. 2011. *Net-zero-energy technology for building retrofit*. Hvac&R Research 17:1-1.
- Ramesh, T., R. Prakash, and K. K. Shukla. 2010. *Life cycle energy analysis of buildings: An overview*. Energy and Buildings 42:1592-1600.
- Sesana, M. M., and G. Salvalai. 2013. *Overview on life cycle methodologies and economic feasibility for ZEBs*. Building and Environment 67:211-216.
- Sodagar, B. 2013. *Sustainability Potentials of Housing Refurbishment*. Buildings 3, no. 1: 278-299.
- U.S. Energy information administration, 2010. *International Energy Outlook 2010*. <http://large.stanford.edu/courses/2010/ph240/riley2/docs/EIA-0484-2010.pdf>
- US Environmental Protection Agency, 2013. *Climate Impacts on Energy*. <<http://www.epa.gov/climatechange/impacts-adaptation/energy.html>>

Net-zero energy retrofits for commercial buildings

Yi Wang¹, Ajla Aksamija¹

¹University of Massachusetts Amherst, Amherst, MA

ABSTRACT: This paper explores feasibility for achieving net-zero energy goals in retrofitting commercial buildings. An existing commercial building in Holyoke, Massachusetts was chosen as the research target to study how to integrate passive design strategies and energy-efficient building systems to improve the building performance and reduce energy consumption. Also, the objective was to investigate how to maximize energy savings and reach net zero energy goals by utilizing renewable energy sources for building's energy needs. Based on modeling and simulations, multiple design considerations were investigated, such as material selection, improvements to building envelope, retrofitting of HVAC and lighting systems, occupancy loads, as well as application of renewable energy sources. The comparative analysis of simulation results was used to determine how specific techniques lead to energy saving and cost reductions. The research results show that this commercial building is able to meet net-zero energy use after appropriate design manipulations and use of renewable energy sources. The strategies and methodologies can be applied to other adaptive reuse and retrofit projects, and to improve energy performance of existing buildings.

KEYWORDS: Commercial Retrofits, Net-Zero Energy, Building Performance, Renewable Energy

1.0 INTRODUCTION

1.1. Background

Buildings exert great influence on greenhouse gas emissions, and can significantly impact their reduction and energy-saving goals if energy-efficiency design strategies are employed. In commercial buildings, high demand of energy for lighting, heating, ventilation, and air conditioning leads to significant amount of carbon dioxide emissions. In 2012, the total end-use sector emission of carbon dioxide from the commercial sector in the United States was 897.9 TgCO₂ Eq., which accounts for nearly 18% of the total U.S. carbon dioxide emission (EPA 2014). The energy consumption for commercial buildings is more than 2.3 trillion Btu, and the increasing trend is expected to continue until the energy produced in the buildings themselves is able to make up for their growing energy needs (DOE 2011). To control this escalating reliance upon fossil fuels and tackle future climate change, it is important to apply effective techniques to upgrade the existing commercial buildings, developing energy efficient commercial buildings based on the integration of advanced energy saving concepts and adaptive reuse methods. On one hand, taking Net-Zero Energy Building (NZEB) concept into commercial retrofits will improve the energy efficiency levels in existing commercial buildings, exploring the possibilities of involving renewable energy sources in order to reduce their dependence on external energy infrastructure. On the other hand, since the life of commercial buildings is extended and possible demolition waste is avoided, net-zero energy commercial retrofits also contribute to the development of a sustainable urban regeneration form.

The idea of NZEB has been widely explored and implemented during the last few years as a way to achieve energy efficiency in the building sector and encourage renewable energy incorporation on-site. Department of Energy (DOE) in the United States has been working on creating technologies and design approaches to develop marketable zero-energy commercial buildings by 2025. Considering the significant portion that commercial buildings take in the U.S. building stock and their high energy consumption level, involving NZEB concept into commercial retrofits will benefit both the preservation of embodied energy in original construction and the reduction of operational energy. Through reusing and upgrading existing buildings, performance of the existing commercial buildings can be improved, thus bringing more opportunities to reinvigorate the large stock of existing commercial buildings and benefit local economies in the long run. Typically, achieving net-zero energy goals can be realized through improving building enclosures, implementing passive design strategies, installing high performance HVAC systems to reduce, heating and cooling loads, reducing lighting and other electric loads, thus making it possible to offset the required energy balance with renewable means, such as solar photovoltaics or wind turbines. Achieving net-zero energy goals is a challenging objective, especially when it comes to retrofit projects, because more constraints are typically imposed on existing buildings than new construction. This paper presents the effective ways to address those physical and economic constraints in commercial retrofits and investigates applicable strategies to achieve NZEBs.

1.2. Literature review

In the concept of NZEB, the fundamental idea is to make buildings meet all their energy requirements by using low-cost, locally available, nonpolluting, renewable sources (Torcellini 2006). For those buildings with electric grid connection, when the energy balance between energy sold and energy used turns out to be zero, they can be qualified as NZEBs (Hootman 2012). Net-Zero Site Energy, Net-Zero Source Energy, Net-Zero Energy Costs, and Net-Zero Energy Emissions are four accounting methods that are commonly used (Torcellini 2006). For Net-Zero Site Energy, renewable energy which is accounted for at the site can offset the annual energy consumption of the building. A Net-Zero Source Energy building is able to provide enough renewable energy to support its annual usage. The energy that is utilized to extract, process, generate, and deliver the energy to the site is considered as source energy in the calculation. Net-Zero Energy costs means that the amount that the building owner gets paid by exporting renewable energy from the building should be equal to or more than the amount of the purchase that the owner made with external energy service utilities. And in Net-Zero Emissions building, emissions from its annual energy consumption should be equal to the emissions-free renewable energy that the building produces or purchases. Even though there is a general understanding towards the NZEB idea, a widely agreed definition that can be consistent with the principles behind the practice of designing and constructing NZEBs internationally is still lacking (Sartori 2012). Recent research towards the definition of NZEB extends its concept to include the consideration of the building's embodied energy and components, thus integrating life cycle energy balance into 'net energy' concept (Hernandez 2010). In this way, it is possible to acquire the true environmental influence that the building has exerted based on the evaluation of both its operating energy use and the energy which is embodied in its structure, materials, and technical installations (Marszal 2011). The life cycle energy balance calculation method can be widely applied to preservation and retrofits projects. In the existing research projects, most NZEB cases use annual balance to support their applied methodologies (Voss 2011), so this paper will still use a balanced annual energy budget to study the achievement of net-zero energy use in commercial retrofits. Net-Zero Source Energy definition is applied in this exploration to investigate the effective ways to generate as much renewable energy as the building needs in a year, thus reducing the electricity consumption of the building to zero.

1.3. Research questions and methods

Through investigating the feasible retrofitting techniques for building performance upgrading, this study explores applicable passive design approaches that can be integrated to achieve energy savings, and the ways to combine the renewable energy generation installations in the limited usable space to provide enough on-site renewable energy for the building. Different energy saving methods are studied and applied in this commercial retrofit project to propose a framework which combines passive design techniques and active design techniques, accompanied by energy modeling and energy simulations to evaluate potential energy savings. Several research questions are addressed in this paper:

- How to manipulate building mass/volume and building envelope to maximize the embodied energy preservation and reduce energy consumption?
- How to use advanced facade system to ensure human comfort and save operating energy? How can we control thermal and lighting loads in old constructions?
- What is the appropriate way to improve the HVAC systems in existing buildings and make it possible that the newly added system will be well adapted to the building?
- How to involve renewable energy sources on site to change the fact that commercial buildings have heavy reliance on external energy infrastructure?

In order to evaluate energy saving performance in retrofit projects accurately, research methodologies included data gathering, adaptive redesign of a case study building, energy analysis, and application of renewable energy systems. Information about the original building was obtained and analyzed to develop redesign strategies that would facilitate the achievement of net-zero energy goals. Building energy models in eQuest were used to assess the impact of energy-efficient design strategies and to explore effective energy saving measures. Different parameters within energy models were varied to perform comparison of base case and alternative runs. Based on the calculation of annual energy balance and consideration of local climate, specific types of renewable energy generation installations were selected and integrated in the retrofit design program to ensure that enough energy can be generated on-site to offset the annual energy balance in the building to zero.

2.0 CASE STUDY: ENERGY EFFICIENCY DESIGN STRATEGIES

The building that was chosen as the target for this research is a 200,000 sf old paper mill, located in Holyoke, Massachusetts. As part of the revitalization plan of south Holyoke, retrofits of commercial buildings will contribute to the development of a stable, healthy and desirable neighborhood in Holyoke in the next ten years, bringing more open space, public facilities, and job opportunities to people who reside in this area. Different energy efficiency design strategies were integrated into the redesign of this building, which are discussed in detail in this section (Fig. 1).

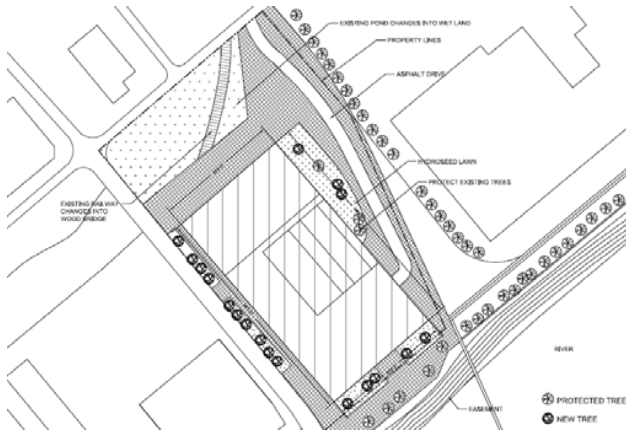

Figure 1: Site plan of the existing building.

2.1. Building envelope

The first step in adaptive redesign was to analyze massing of the existing building, structure, and spatial organization, and to determine how exactly the building form will be changed and improved. It was determined that parts of the building will be demolished (mainly, parts of the second and third floor), and that two additional floors will be added to accommodate new building program, which includes offices, classrooms, museum, retail space, and a restaurant. The middle part of the building was redesigned into a courtyard, which allowed the building to get back to its appearance when it was first built in 1895 (the initial interior courtyard was closed off in 1960's). With this retrieved courtyard, daylighting and natural ventilation are integrated as passive design techniques to reduce the electricity consumption. Extraction of the existing building mass and addition of a new building mass create several roof gardens, which offer public space for occupants, provide an area for placement of photovoltaics panels, and bring potential building energy reduction benefits (Fig. 2). Adding green roofs to different levels of the building also improves the thermal performance of the roof, hence leading to decreased heat gain during the summer and heat loss during the winter. Also, annual internal temperature becomes more stabilized because green roof add thermal mass to the building (Castleton 2010).

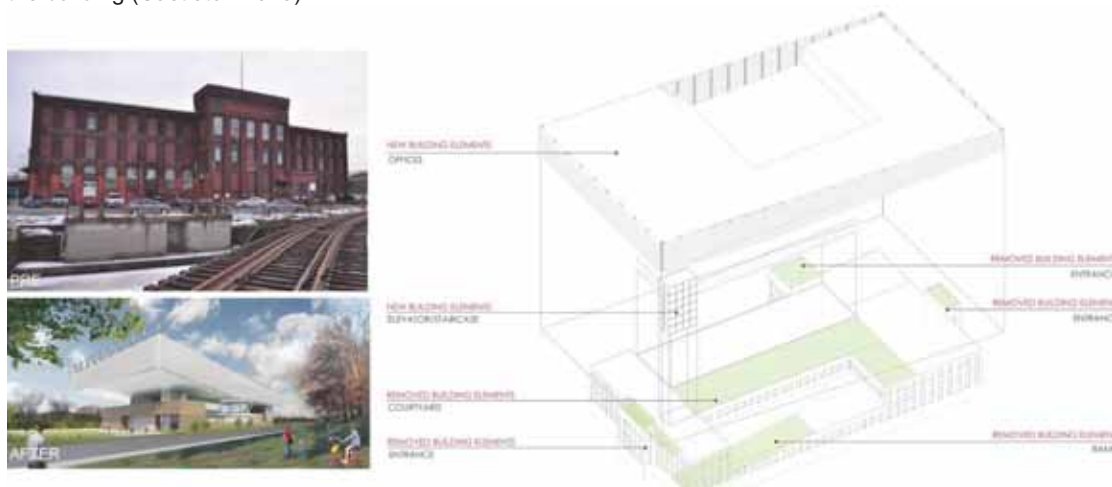

Figure 2: Pre and post retrofit views of the building.

Building envelope upgrade was also achieved by improving the exterior wall insulation to control the heat, air, and moisture transfer between the wall assemblies and the exterior environment. Newly added thermal insulation, air barrier, and vapor retarder help the building acquire improved insulating and air sealing performance, and at the same time, ensure that the moisture problem can be addressed adequately. Expanded polystyrene (EPS) rigid insulation panels and fiberglass batt insulation within the framing cavity were added to resist the heat flow and increase the R-value of the wall assemblies. Based on both energy efficiency and moisture control considerations, this facade retrofit design improves the thermal envelope of the existing building, providing an effective way to improve energy efficiency and maintain the moisture

For the top two floors, a new facade system was designed to provide appropriate visual environment for the office areas and make full use of daylight to reduce energy consumption for lighting. Curtain wall system and exterior horizontal sunshades system are combined together to achieve environmental optimization and energy efficiency. The sunshades system is made of 12" wide aerofoil-shaped blades connected to the framing system with mounting arms and mounting brackets (Fig.4). This shading system controls the direct solar exposure and glare, making interior daylighting environment ambient and comfortable.

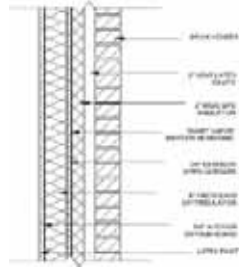

Figure 3: Facade system.



Figure 4: Curtain wall and shading system.

2.2. Passive design strategies

Involvement of passive design strategies plays an important role in achieving energy savings in this commercial retrofit design. Passive design strategies improve energy consumption by designing the building form that responds to the environment, thus making it possible that to achieve high interior environmental quality and low-energy demand at the same time (Hootman 2012). One of the most important applications of passive design strategies that was applied to this building is to make full use of daylight. Since most activities occurring in this building are during the daytime, using natural light can greatly reduce the reliance upon artificial lighting. Also, cooling loads can be reduced if daylight is widely used in the building, because even energy-efficient lighting fixtures can bring significant amount of heat during use (Aksamija 2013). Approaches developed for maximizing exposure to natural light and controlling incoming daylight are based on the comprehensive thinking towards the redesign of the building's programs, layout, mass, and facade. Daylighting design is developed based on the function of the space, requirement towards lighting quality, and aesthetic value of the building facade. To better daylighting performance and improve the interior lighting quality, manipulation towards the building mass was combined with integrated shading devices to minimize direct daylight and encourage reflective daylight in order to achieve diffusive lighting performance. Plus, building mass's redesign also facilitated passive wind driven ventilation to reduce cooling loads in the building. These design strategies are portrayed in Figure 5.



Figure 5: Passive design strategies.

2.3. HVAC systems

Efficient HVAC systems can improve human comfort and air quality in the building with application of advanced heating, ventilation, and air conditioning technologies. Integrated HVAC systems in this retrofit project were used to reduce the energy demand of the primary equipment and ensure low-energy distribution. Biomass heating system is integrated into the building's HVAC system by combusting biomass fuels, which add to significant cost-saving, environmental, and social benefits. Since wood, agriculture residues, and crops are the most common fuels for biomass energy systems, easy accessibility to these organic matters in western Massachusetts area leads to reduced delivery and storage cost (Salameh 2014). Compared to emissions related to combusting of coal or oil, pollutants linked to biofuel combustion, such as nitrogen oxide and sulphur dioxide, are within lower amount (Fabrizio 2014).

Delivery of heating, cooling, and ventilation services to each part of the building effectively and energy-efficiently is critical in low-energy HVAC system design. Smart control systems for temperatures management in HVAC system can successfully save energy during the operation. By using modest temperatures instead of extreme temperatures in the working fluids, it is possible to make better use of natural resources for heating and cooling, protect the primary equipment, and minimize reheat energy. Commercial HVAC smart control system is taken into the HVAC system retrofit to facilitate intelligent

integration and optimization of HVAC system components in the building. Wireless temperature monitoring system was considered as a strategy to improve HVAC control in the building, allowing that temperatures in rooms with different functions can be adjusted intelligently according to their occupancy, human activities, and specific requirements. Advanced wireless sensor technology allows required real-time data in the building to be collected efficiently by the sensors. After the data is recognized by the main computer monitoring system, signals can be sent based on the analysis of the collected data to control the supply air temperatures and speed of the fan coil units. Reliable wireless monitoring system can effectively reduce energy consumption during the operation of HVAC system and keep room temperature appropriately to ensure human comfort. Also, compared to conventional wire solution, wireless installation is cost-effective for retrofit application with significantly reduced labor cost. This type of system was considered for this project.

3.0 MODELING AND SIMULATIONS

3.1. Energy modelling

Using simulation software eQuest to build and analyze energy model of this commercial complex allowed us to understand the energy consumption quantities, explore the energy saving potentials, evaluate different sustainable design alternatives, and assist decision making process for choosing feasible and reliable approaches (Fig. 6).

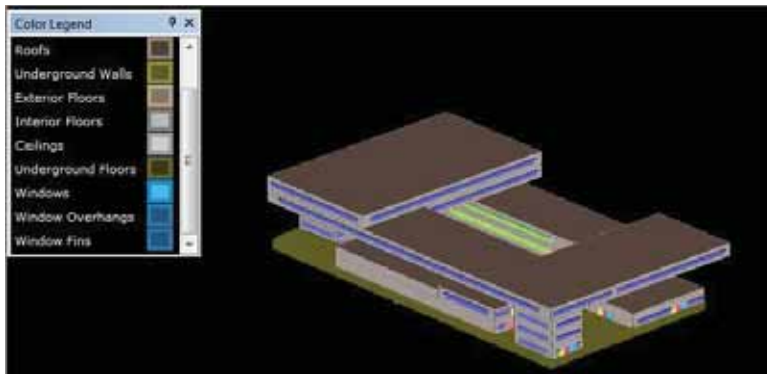

Figure 6: Energy model in eQuest.

Building energy performance assessment was developed based on the creation of a virtual environment of the building within its geometric configuration. Input data about building materials allows building envelope system to be simulated accurately, and by varying the layers in the assemblies and parameters, it is possible to understand the energy consumption fluctuations and determine solutions to maximize energy saving potentials. Since this building has a complex form and different functions, the whole building energy model was developed by building four shells and organizing them together in one model. Input data for every shell was determined according to its size and program, building envelope treatment and system loads (Table 1). By manipulating building materials, lighting power density, occupancy schedules, cooling, heating, and lighting loads in the building were lowered significantly to acquire maximized energy savings.

The baseline simulation showed high annual energy consumption, with Energy Use Intensity (EUI) of 120 kBtu/ft². Deep retrofit measures designed to address this problem incorporated control of internal loads and operating schedules, lighting, and improvement in the building envelope. For museum, classrooms, stores, and offices, different demand for interior lighting environment and occupancy schedules were taken into consideration in energy modeling improvement process. Lighting power density (LPD), which is an important value associated with energy efficient lighting design was reduced for all spaces in the building. In addition, planning and rescheduling work time for every functional room made it possible that significant lighting energy can be saved according to real occupancy situation, and accompanied occupancy sensors design ensured that waste lighting electricity for unoccupied rooms is minimized. After applying all the possible energy saving strategies, an alternative simulation run in eQuest was conducted to acquire a comparison analysis, lowering the EUI value to 52 kBtu/ft². By comparing baseline run and alternative run, it was evident energy performance improvement can be acquired after implementation of available and effective approaches (Fig. 7).

Table 1: Input for shells.

Building Type	Office Building, Two Story	Retail, Department Store
Jurisdiction	ASHRAE 90.1	ASHRAE 90.1
Building Area	75,000sf	11,200sf
Cooling & Heating	Cooling Equipment: DX Coils Heating Equipment: Hot Water Coils	Cooling Equipment: DX Coils Heating Equipment: Hot Water Coils
Interior Construction	Ceilings: Int Finish / Lay in Acoustic Tile Vertical Walls: Wall Type / frame Floors: Int. finish / Vinyl Tile Construction / 4 in. Concrete Concrete Cap / 1.25 in. LW Concrete	Ceilings: Int Finish / Lay in Acoustic Tile Vertical Walls: Wall Type / frame Floors: Int. finish / Vinyl Tile Construction / 4 in. Concrete Concrete Cap / 1.25 in. LW Concrete
Glass Type	Double Clr/Tint (2006 Version) Versalux Grey/Air/ Clear 6 mm	Double Clr/Tint (2006 Version) Versalux Grey/Air/ Clear 3 mm
Daylighting	Ground Floor and Top Floor Daylit from / Side Lighting Light Control method (by photosensors): Dimming 30% Light (30% pwr)	Ground Floor and Top Floor Daylit from / Side Lighting Light Control method (by photosensors): Dimming 30% Light (30% pwr)
Lighting Power Density	Office-Enclosed: 1.10 watts/sf Office-Open Plan: 1.10 watts/sf Conference/Meeting: 1.30 watts/sf Lounge: 0.80 watts/sf Restroom: 0.80 watts/sf Corridor: 0.90 watts/sf	Retail: 1.25 watts/sf Storage: 0.60 watts/sf Restroom: 0.80 watts/sf Corridor: 0.90 watts/sf
Main Schedule Information	First (& Last) Season Day 1: M,T,W,Th,F, CD,HD Day 2: Sa Day 3: Su, Hol Day 1: Opens at: 8AM; Closes at 5 PM; Occup % /90%; Lites Ld %/90, Equip Ld %/90 Day 2: Opens at: 8AM; Closes at 5 PM; Occup % /10%; Lites Ld %/10, Equip Ld %/10 Day 3: Unocc Second Season(Sat, Aug 04 thru Sun, August 31) Day 1: M,T,W,Th,F, CD,HD Day 2: Su, Hol Day 1: Opens at: 8AM; Closes at 5 PM; Occup % /10%; Lites Ld %/10, Equip Ld %/10 Day 2: Unocc	Day 1: M,T,W,Th,F, CD,HD Day 2: Sa, Su, Hol Day 1: Opens at: 9AM; Closes at 7 PM; Occup % /90%; Lites Ld %/90, Equip Ld %/90 Day 2: Opens at: 9AM; Closes at 10 PM, Occup % /90%; Lites Ld %/90, Equip Ld %/90
Building Type	Museum	Community Center
Jurisdiction	ASHRAE 90.1	ASHRAE 90.1
Building Area	10,700sf	47,6vv00sf
Cooling & Heating	Cooling Equipment: DX Coils Heating Equipment: Hot Water Coils	Cooling Equipment: DX Coils Heating Equipment: Hot Water Coils
Interior Construction	Ceilings: Int Finish / Lay in Acoustic Tile Vertical Walls: Wall Type / frame Floors: Int. finish / Vinyl Tile Construction / 4 in. Concrete Concrete Cap / 1.25 in. LW Concrete	Ceilings: Int Finish / Lay in Acoustic Tile Vertical Walls: Wall Type / frame Floors: Int. finish / Vinyl Tile Construction / 4 in. Concrete Concrete Cap / 1.25 in. LW Concrete
Glass Type	Double Clr/Tint (2006 Version) Versalux Grey/Air/ Clear 3 mm	Double Clr/Tint (2006 Version) Versalux Grey/Air/ Clear 6 mm
Daylighting	Ground Floor and Top Floor Daylit from / Side Lighting Light Control method (by photosensors): Dimming 30% Light (30% pwr)	Ground Floor and Top Floor Daylit from / Side Lighting Light Control method (by photosensors): Dimming 30% Light (30% pwr)
Lighting Power Density	Museum: 1.06 watts/sf Corridor: 0.90 watts/sf	Workshop: 1.20 watts/sf Dining/Cafeteria: 1.30 watts/sf Lounge: 0.80 watts/sf Library: 1.18 watts/sf Gym: 1.00 watts/sf Office-Enclosed: 1.10 watts/sf Restroom: 0.80 watts/sf Corridor: 0.90 watts/sf
Main Schedule Information	First (& Last) Season Day 1: M,T,W,Th,F, CD,HD Day 2: Sa Day 3: Su, Hol Day 1: Opens at: 9AM; Closes at 5 PM; Occup % /90%; Lites Ld %/90, Equip Ld %/90 Day 2: Opens at: 10AM; Closes at 4 PM; Occup % /10%; Lites Ld %/10, Equip Ld %/10 Day 3: Unocc Second Season(Sat, Aug 04 thru Sun, August 31) Day 1: M,T,W,Th,F, CD,HD Day 2: Su, Hol Day 1: Opens at: 10AM; Closes at 4 PM; Occup % /10%; Lites Ld %/10, Equip Ld %/10 Day 2: Unocc	First (& Last) Season Day 1: M,T,W,Th,F, CD,HD Day 2: Sa Day 3: Su, Hol Day 1: Opens at: 11AM; Closes at 7 PM; Occup % /90%; Lites Ld %/90, Equip Ld %/90 Day 2: Opens at: 10AM; Closes at 8 PM; Occup % /90%; Lites Ld %/90, Equip Ld %/10 Day 3: Opens at: 10AM; Closes at 10 PM; Occup % /90%; Lites Ld %/90, Equip Ld %/10 Second Season(Sat, Aug 04 thru Sun, August 31) Day 1: M,T,W,Th,F, CD,HD Day 2: Su, Hol Day 1: Opens at: 8AM; Closes at 8 PM; Occup % /90%; Lites Ld %/90, Equip Ld %/90 Day 2: Opens at: 8AM; Closes at 10 PM; Occup % /90%; Lites Ld %/90, Equip Ld %/90

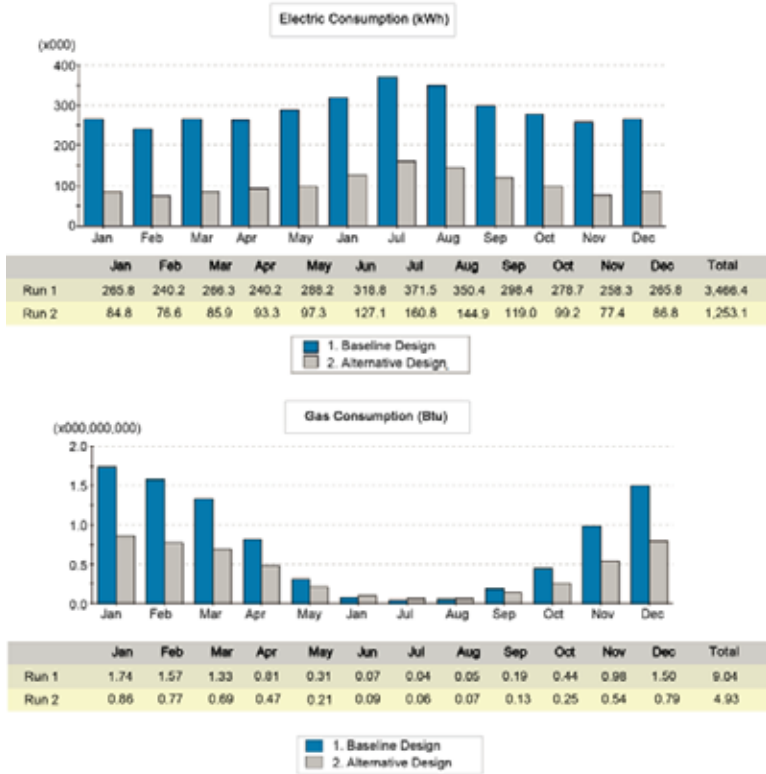

Figure 7: Results of energy modeling (annual electricity and gas consumption) simulations.

Other energy efficiency approaches involved in the improvement of energy model included using materials that have high thermal mass and durability, such as stone, as well as applying better insulated glazing. Since windows account for most energy loss in the building and glazing is so crucial to window energy efficiency, improving glazing is an effective way to reduce energy transfer through the windows. Double glazing with low-e coating and argon gas fill was selected to substitute glazing for windows, thus significantly reducing heat transfer through the building envelope significantly. And the three critical properties in evaluating the glazing’s energy performance – visible light transmittance, solar heat gain coefficient, and insulating performance – were also taken into consideration during the decision making process.

3.2. Renewable energy systems

According to the simulation results for monthly energy usage, it was evident that renewable energy sources are necessary to achieve net-zero energy goals. Comprehensive thinking towards energy conversion ratio, feasibility, accessibility, and cost contributed to the decision of selecting four types of renewable energy systems to work together, generating enough energy to support the operation of the building system (Fig. 8).



Figure 8: Integrated renewable energy system.

High efficiency commercial photovoltaics were considered to be placed on the roofs. Since the applied photovoltaics are integrated in a grid-connected system, direct current power which is generated by the PV arrays is converted into alternating current by the power conditioning unit to satisfy the building’s energy demand (Masters 2014). Applying this grid-connected PV system in commercial retrofit project has a number of benefits. With relatively simple configuration, it is easy to install and maintain the devices. Also, considering the limited site around the existing building, high efficiency PV panels with desirable power

demand. In addition, the working schedule for most spaces in the building are during the daytime, so PV system can deliver power during the peak time when utility rates are relatively high. The design of PV arrays involved a series of 240 PV panels, covering 50,000 sf roof areas to provide approximately 4,000,000 kBtu energy annually. In addition, wind turbines were considered to be installed on top of the building to capture wind energy on site. Medium vertical axis wind turbines which are 4ft wide and 8ft high with 2KW generator were selected to be installed on the roof to generate about 1,800,000 kBtu energy per year. The reasons for choosing this type of wind turbines included their high efficiency, possibility to catch wind from all directions and simplicity in mechanical configuration. Since vertical axis wind turbines are without downwind coning, rudders, and yaw mechanisms and their electrical generators are positioned close to the base, they are easy to install and maintain.

Biomass and hydropower were also used in the design of renewable energy systems based on the consideration of the accessibility towards the resources. Holyoke is located in western Massachusetts area, which has rich agricultural resources, so it is cost-efficient to collect and deliver biomass materials. The last renewable energy source that was considered for the retrofit design of the building's energy system is hydropower. The location of this building was the primary reason for including hydropower. Right beside an important canal of Holyoke, this building can integrate the hydropower system in it with easiness. Although site-based hydropower is not widely used in commercial buildings due to specific site requirements and access to water, this particular building has a great potential due to its proximity to canal and existing hydropower turbines in the City of Holyoke. Different from solar power, which only works during the daytime with enough solar radiation, hydropower's availability is very flexible, so it is possible to get a long-term, stable, and dependable payback with one-time investment. For this building scale, a micro hydro system is suitable for placement, and a turbine can be applied to transform potential energy from the water flow into mechanical energy first, and this mechanical energy can be transformed into electric power later for building usage. Incentives for micro system applications are widespread, which can offset a significant part of the cost for equipment purchase and instalment (Jenkins 2013).

The renewable energy systems that incorporate solar energy, wind energy, biomass, and hydroenergy made it possible to achieve net-zero energy goals, thus meeting the energy demand of the building with renewable energy sources on site. The breakdown of the supplied energy by renewable sources is shown in Figure 9, where solar energy accounts for 45% of the total renewable energy support, satisfying the energy needs of the building as the major renewable energy source (Fig. 10). Hydroenergy, biomass, and wind energy systems work together to make up for the rest energy need, generating more than 5 million kBtu energy annually.

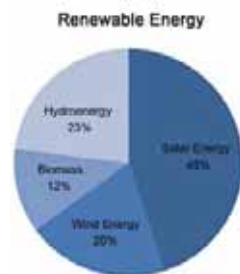

Figure 9: Renewable energy sources.

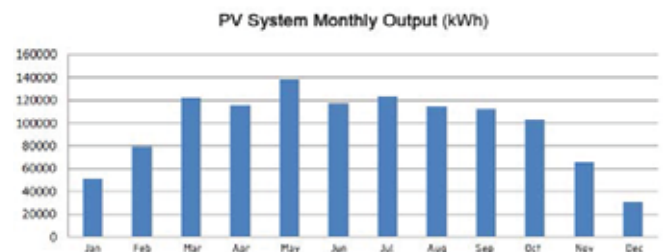

Figure 10: PV system energy output.

4.0 CONCLUSION

In exploring the applicable net-zero energy design approaches for commercial retrofits, rethinking towards the NZEB concept and all the possible strategies that can be integrated into an existing building must be taken into account. It is necessary to consider comprehensive methods for sustainable design, adaptive reuse, and new energy systems. Achieving net-zero energy goals in commercial retrofits with available technologies is challenging. However, with careful attention to adaptive design strategies, building envelope treatment, passive design approaches, appropriate HVAC systems and utilization of renewable energy sources it is possible to achieve that goal. Energy modelling and simulations, which uncover the energy saving potentials in every energy-saving measure, are beneficial tools in retrofit design and should be widely applied. Local resources, environment, and human activity should be considered during the decision making process, contributing to develop an integrated building system that enables new opportunities for energy saving and building performance improvements.

REFERENCES

- Anna Joanna Marszal, Per Heiselberg, Julien S. Bourrelle, Eike Musall, K. Voss, Igor Sartori, A. Napolitano. "Zero Energy Building - A Review of Definitions and Calculation Methodologies." *Energy and Buildings* 43 (2011) 971-979.
- Ajla Aksamija. *Sustainable Facades: Design Methods for High-Performance Building Envelopes*. Hoboken, NJ: John Wiley & Sons, Inc., 2013.
- Dilwyn Jenkins. *Renewable Energy Systems: The Earthscan Expert Guide to Renewable Energy Technologies for Home and Business*. New York: Routledge, 2013.
- Enrico Fabrizio, Federico Seguro, Marco Filippi. "Integrated HVAC and DHW Production Systems for Zero Energy Buildings." *Renewable and Sustainable Energy Reviews* 40 (2014) 515-541.
- Gilbert Masters. *Renewable and Efficient Electric Power Systems*. Hoboken, NJ: John Wiley & Sons, 2004.
- Holly Castleton, V. Stovin, S.B.M. Beck, J.B. Davison. "Green Roofs; Building Energy Savings and The Potential for Retrofit." *Energy and Buildings* 42 (2010) 1582-1591.
- Igor Sartori, Assunta Napolitano, Karsten Voss. "Net Zero Energy Buildings: A Consistent Definition Framework." *Energy and Buildings* 48 (2012) 220-232.
- Karsten Voss, Eike Musall, and Markus Lichtmes. "From Low-Energy to Net Zero-Energy Buildings: Status and Perspectives." *Journal of Green Building*, 6 (2011): 46-57.
- Karsten Voss, Eike Musall, J Roderick O'Donovan. *Net Zero Energy Buildings: International Projects of Carbon Neutrality on Buildings*. Munich: Detail green Books, 2013.
- Patxi Hernandez, Paul Kenny. "From Net Energy to Zero Energy Buildings: Defining Life Cycle Zero Energy Buildings (LC-ZEB)." *Energy and Buildings* 42 (2010) 815-821.
- Paul Torcellini, Shanti Pless, and Michael Deru. *Zero Energy Buildings: A Critical Look at the Definition*. Conference Paper NREL/CP-550-39833. June, 2006
- Thomas Hootman. *Net Zero Energy Design: A Guide for Commercial Architecture*. Hoboken, NJ: John Wiley & Sons, 2012.
- United States Department of Energy (US DOE): Building Technologies Program. *Planned Program Activities for 2008-2012*. Washington 2008. <http://www1.eere.energy.gov/buildings/vision.html>.
- United States Environmental Protection Agency (EPA). *Inventory of U.S. Greenhouse Gas Emission and Sinks: 1990 – 2012*. Washington, DC: U.S. Environmental Protection Agency, 2014.
- Ziyad Salameh. *Renewable Energy System Design*. Waltham, Massachusetts: Academic Press, 2014.

Towards net-zero energy: Lessons for architectural design education

Mary Guzowski¹

¹University of Minnesota, Minneapolis, Minnesota, USA

ABSTRACT: This paper explores the goals, methods, and lessons from six years of teaching a required graduate course focusing on the integration of luminous and thermal design for net-zero energy architecture. An integrated approach to passive heating, natural ventilation, and daylighting were at the core of this design curriculum, into which innovative systems and renewable energy were integrated. Design excellence, comfort, and human experience were of equal importance as energy and ecological performance. The goal of the course was to foster student awareness, intuition, and design skills to support qualitative and quantitative decision making in the early phases of low- and net-zero energy architectural design. The objective of this paper is to share the teaching and learning goals, net-zero energy design protocols, and assessment methodologies. Concluding lessons for design educators will address pedagogical consideration for developing a net-zero energy architecture curriculum.

KEYWORDS: Net-zero Energy, Architectural Education, Energy Modeling, Passive Solar Design

INTRODUCTION

The aspiration for net-zero (and increasingly net-positive) energy architecture is generating an evolution in the design professions and a transformation in architectural education. To prepare students for the energy and ecological challenges of our day, net-zero energy is now a foundational topic for design studio and related topical courses. To meet these pressing professional needs, the School of Architecture at the University of Minnesota has explored and tested three distinct models for teaching a required net-zero design curriculum for the first year graduate students in the professional M.Arch program. The paper will discuss educational goals, metrics, design protocols, and student outcomes. Concluding lessons will address pedagogical consideration for developing courses for net-zero design education. (In the following sections the term “net-zero energy” will be used; however the author acknowledges the critical shift to “net-positive energy” architecture which produces on an annual basis more energy than it consumes.)

Research by the US Green Building Council (USGBC) confirms this trend: “*While ZNE [zero-net energy] buildings currently make up a very small fraction of the overall green building market today, it’s clear that this new frontier in sustainability is gaining traction*” (Dorn, USGBC). The New Building Institute’s (NBI’s) 2014 *Getting to Zero Status Update* studied 160 buildings constructed since 2012 and concludes:

Zero net energy (ZNE) buildings have captivated the minds of leading design firms, companies, schools, foundations and governments that are showing the way to a lower-carbon future. In just a few years ZNE has transitioned from an impossible concept to a quite probable future. ZNE buildings have now moved beyond a handful of small demonstration projects by universities or nonprofits to more widely mainstream building types and sizes. (NBI, 1, 10).

To meet every higher levels of energy performance, both the USGBC and the NBI underscore the need to explore new approaches to programming, architectural design, technology, systems, and operations (USGBC, NBI). To reach these new levels of energy performance, architects are integrating ancient lessons of passive and climate-responsive design with state-of-the art technologies and new, innovative approaches to high-performance and responsive building envelopes.

1.0 NET-ZERO DESIGN EDUCATION

The ability to define fundamental energy-consumption and sustainable performance metrics, strategies, and assessment methods is often lacking in both the academy and practice, at the same time as the shifting aspiration from net-zero to net-positive energy design continues to raise the bar. The need for clearly articulated performance criteria, metrics, and assessment protocols to measure design outcomes is identified as the first of four research priorities and trends in the *AIA Sustainability Leadership Opportunity Scan*:

#1: Drive for measured performance: The global design and construction industry is transitioning from loose, aspirational sustainable goals to measured performance expectations and requirements. Optional rating systems (such as LEED) helped set the stage for this approach, but requirements are expanding to include actual performance and measured design outcomes (AIA 2013, 7).

While the profession and the academy are grappling with the complexity of defining metrics, there is also the challenge of defining effective teaching methods and protocols. In 2006, the *Architecture 2030 Challenge* made the call to the profession and educational institutions for incremental shifts to “carbon-neutral design by the year 2030” and launched the 2010 *Imperative* “Global Teach-in” in 2007. For accredited programs of architecture, the first reference to “carbon-neutral design” (and indirectly net-zero energy) appeared in the

2009 Conditions for Accreditation by the National Architectural Accreditation Board (NAAB). Yet despite the 2009 trajectory to integrate net-zero and carbon-neutral design into architectural education, NAAB's 2014 Conditions for Accreditation have recently removed the criterion for "Sustainability" and replaced it with "Integrative Design." The new criterion eliminates "carbon-neutral design" (and indirectly net-zero energy) to be replaced by the less energy-specific description "environmental stewardship" (NAAB, 2014, 18-19). Please see Table 1 for related criteria from the 2009 and 2014 Conditions for Accreditation.

Table 1: NAAB Conditions for Accreditation 2009 and 2014 (NAAB 2009, 24-25 and NAAB 2013, 18-19).

NAAB 2009 Conditions for Accreditation July 2009:	NAAB 2014 Conditions for Accreditation, First Draft August 2013
B. 3. Sustainability: Ability to design projects that optimize, conserve, or reuse natural and built resources, provide healthful environments for occupants/users, and reduce the environmental impacts of building construction and operations on future generations through means such as carbon-neutral design, bioclimatic design, and energy efficiency.	Integrative Design: Ability to produce an architectural solution that demonstrates the ability to make design decisions about a single project while demonstrating broad integration and consideration of environmental stewardship, technical documentation, accessibility, site conditions, life safety, environmental systems, structural systems, and building envelope systems and assemblies.
B. 8 Environmental Systems: Understanding the principles of environmental systems' design such as embodied energy, active and passive heating and cooling, indoor air quality, solar orientation, daylighting and artificial illumination, and acoustics; including the use of appropriate performance assessment tools.	B.6 Environmental Systems: Understanding the principles of environmental systems' design, which must include active and passive heating and cooling, indoor air quality, solar orientation, daylighting and artificial illumination, and acoustics; and an understanding of performance assessment tools.

While there is a great desire to teach net-zero design, practical teaching methods and tools are still in the nascent stage. There are no clear pedagogical directives or organized approaches by the Associate Collegiate Schools of Architecture (ACSA), the National Council of Architectural Registration Boards (NCARB), or the National Architectural Accrediting Board (NAAB). For educators trying to develop a curriculum using emerging definitions and protocols, institutional support from ACSA and NAAB are essential in leveraging from administrators the necessary time and funding to develop teaching resources.

2.0. A CURRICULUM RESPONSE FOR NET-ZERO DESIGN

The School of Architecture at the University of Minnesota has explored three approaches since 2008 to integrating net-zero design education into the professional M.Arch program. The required graduate-level course focused on the integration of luminous and thermal design strategies and technologies to eliminate fossil fuel energy consumption in building operations for heating, lighting, and cooling. An integrated approach to passive heating, natural ventilation, and daylighting were at the core of this design curriculum, into which innovative systems and renewable energy were integrated. Design excellence, comfort, and human experience were given importance equal to energy and ecological performance. The desired outcome of the course was to foster student awareness, design skills, and intuition to support qualitative and quantitative decision making in the early phases of programming and schematic design of low- and net-zero energy architectural design. The following discussion outlines the curriculum development process over the past six years.

2.1. Assemble a net-zero teaching cohort

Given the complexity and emerging nature of the topic, the School has reached out to energy experts and sustainable design researchers to help develop and teach net-zero design strategies and methods. It was essential to assemble a faculty cohort with expertise in both net-zero design in professional practice as well as curriculum development and teaching. The faculty cohort was structured to include either a full-time faculty member or a full-time research practitioner responsible for curriculum oversight and coordination and two part-time adjunct faculty from practice with expertise in energy and/or digital assessment methods and tools. Despite innovative regional guidelines and design resources for the *Minnesota Sustainable Design Guide* as well as the *State of Minnesota Energy Design Assistance Program*, there are few local and regional professionals who have expertise in net-zero design in the early design phases. One of several goals of the net-zero curriculum is to enable students to enter the profession with viable and transferrable early net-zero energy design knowledge and skills.

2.2. Clarify net-zero educational goals

Although the course has been taught in various formats, the goals have remained consistent: 1) Promote ecological and holistic systems thinking, 2) Explore formal, aesthetic and experiential design opportunities, 3) Integrate appropriate design and technology applications, and 4) Develop methods of design and performance assessment and testing. As a required course for the graduate cohort designated to meet the level of "ability" specified in the *NAAB Criterion: B3: Sustainability*, it was essential that tangible design strategies, assessment methods and tools be introduced and actively applied to design by the students ("...ability' to design projects that optimize, conserve, or reuse natural and built resources ...through means such as carbon-neutral design, bioclimatic design, and energy efficiency," NAAB, 2009). Passive design and its role in reducing energy consumption in cold-climate architecture were at the heart of the curriculum.

2.3. Define net-zero design curriculum format

A significant structural challenge was how to include in an already dense curriculum the additional time and expertise essential to develop, test, and implement a net-positive energy curriculum. During the past six years, the net-zero energy course has been taught in three formats: 1) two 3-credit, 15-week parallel technology lecture courses, 2) a 6-credit, 7-week hybrid lecture course and technology studio, and 3) and a 9-credit, 15-week ecological comprehensive design studio. In all of the course formats, the students moved through a series of exercises taking net-zero thermal and luminous energy design from the site to building, envelope, and systems scales. The net-zero design and assessment protocol for the course includes four steps and a sequence of related assignments: 1) set project goals, 2) minimize loads, 3) meet energy loads, and 4) use renewable sources (a detailed discussion is provided below in *Section 3.0: A Net-Zero Design Protocol*).

2.4. Assess net-zero teaching resources

Evaluating and building upon existing teaching resources and tools is essential given the emerging nature of net-zero design. Useful resources include the *Carbon Neutral Design Project* and the *2030 Palette*. To provide support for design educators, the *Society of Building Science Educators and AIA* have created the *Carbon-Neutral Design Project* to share teaching resources across schools of architecture in North America (SBSE, 2010). With twenty-six faculty from schools of architecture participating in the project by sharing syllabi, course assignments, toolkits, and assessment methods, the website includes an excellent cross-section of curricular approaches. Additional funding is needed to keep the effort updated with the most current teaching methods and outcomes. An alternate resource is provided by *Architecture 2030*, which launched the *2030 Palette* to provide design strategies and case-studies. Although not a design or assessment tool, the *2030 Palette* provides “*The principles and actions needed to create low-carbon and resilient built environments worldwide*,” including excellent case studies, strategy guidelines, rules-of-thumb, and resources across scales, topical areas, and climate (Architecture 2030).

While these and related resources are extremely useful for design education, there is an urgent need for user-friendly design protocols and tools in the early schematic design phase to enable students (and practitioners) to easily and quickly compare design strategies and trade-offs. Learning, evaluating, and integrating the most effective assessment tools requires time and expertise, given the diversity of early design tools such as *Sefaira Concept* and more robust assessment tools such as *Integrated Environmental Solutions Virtual Environment* (IES VE Pro). Several assessment tools were used in the first six years in the course, including *Ecotect*, *Diva*, *IES VE*, and *Sefaira Concept*. While the most effective program for design integration for thermal, luminous, and systems was found to be *IES VE*. Since tools are under continuous development, students are taught to master design protocols and assessment methods rather than a specific tool.

Total Building Gross Square Feet (SF)	COMPOSITE SB 2010-15 Energy Standard kBtu/SF/yr	COMPOSITE SB 2010-15 Carbon Footprint lbs/SF/yr
0	-	-

New Construction: Sustainable Building 2030 Energy Standards for Years 2010-16			
Building Type	Enter Gross Square Feet of each Building Type	SB 2010-15 Energy Standard kBtu/SF/yr	SB 2010-15 Carbon Footprint lbs/SF/yr
1 Administration		46.6	19.8
2 Animal Shelter		109.5	50.3
3 Auditorium		48.4	21.3
4 City Hall		52.4	20.3
5 Coliseum/Stadium		32.7	12.2
6 College Classroom		79.4	26.6
7 College Laboratory		199.9	55.3
8 Community Center		46.6	15.0
9 Computer Center		79.4	26.6
10 Courthouse		46.6	19.8
11 Data Center		321.9	190.9
12 Detached Kitchen		77.9	26.6
13 Dental Lab		199.9	55.3
14 Detonatory		46.6	17.9
15 Elementary School		57.1	16.1
16 Field House/Gym		60.2	17.8
17 Fire Station		60.2	21.3
18 Greenhouse		132.6	37.3
19 High School		53.1	16.4
20 Hospital		94.5	30.9
21 Ice Arena		90.1	34.0
22 Kitchen/Dining		52.7	21.7
23 Library		58.9	20.6
24 Machine Shop		70.4	30.5
25 Maintenance Repair		40.8	12.5
26 Mechanical		20.2	8.9
27 Middle School		53.9	15.9
28 Multi-Family Housing		49.8	13.3
29 Museum		95.4	37.6
30 Nursing Home		45.3	22.3
31 Office		49.8	19.8
32 Park/Recreation		38.8	11.3
33 Parking Garage		20.2	7.2
34 Parking Lot		2.2	1.2
35 Pairs Assembly		65.8	27.9
36 Police Facility		61.5	22.1
37 Prison/Jail		46.6	16.0
38 Prison Housing		85.1	22.8
39 Retail/Store		55.4	25.9
40 Retirement Home		35.7	12.8

Figure 1: SB2030 Energy Worksheet is used to define the 2030 Baseline for the given year. Source: (SB2030, 2014).

2.5. Develop, test and revise curriculum

Over the past six years, the faculty cohort has worked with Dr. Ilene Alexander from the Center for Teaching and Learning Services (CTLs) to develop the course, conduct mid-course evaluations, and to critique the course effectiveness. The partnership with CTLs has been essential in having an objective assessment of the strengths and weakness of the curriculum and in focusing efforts to improve the course.

3.0. A NET-ZERO DESIGN PROTOCOL FOR ARCHITECTURAL EDUCATION

3.1. Set project energy goals: define baseline and programming opportunities

The *Architecture 2030 Challenge* goal of incremental steps toward “carbon-neutrality” is used as the “energy and carbon baseline” from which students develop design strategies to reduce energy toward “net-zero and beyond.” The *State of Minnesota Sustainable Building Guideline’s SB2030 Energy Standard Worksheet for New Construction* (SB2030) is used to define

the baseline energy and carbon benchmark for the *Architecture 2030* incremental carbon-reduction target for the given year, building type, program activities, and square footage. The *SB2030 Worksheet* has the advantage of being tailored to regional building energy codes and a cold-climate building energy database. This baseline provides the current-day energy requirements to meet the *Architecture 2030* incremental target, for example in 2014, buildings have to meet 60% energy and carbon reductions from an average building for a given program, locale and climate. The baseline metrics are used to compare design strategies over the development of the project, using the *Energy Standard in kbu/SF/Yr* and the related *Carbon Footprint in lbs/SF/Yr* (*SB2030 Worksheet*: <http://sb2030.twgidemo.com/SB2030Calculator/>). In addition to quantitative benchmarks, students are asked to develop a “luminous and thermal program” exploring the qualitative and experiential dimensions of net-zero design and programming opportunities for energy and carbon reduction. The “luminous and thermal program” provides an opportunity for students to weigh the balance of energy targets with thermal and luminous comfort as well as the desired seasonal qualities and atmosphere of the architectural spaces (Figure 2).

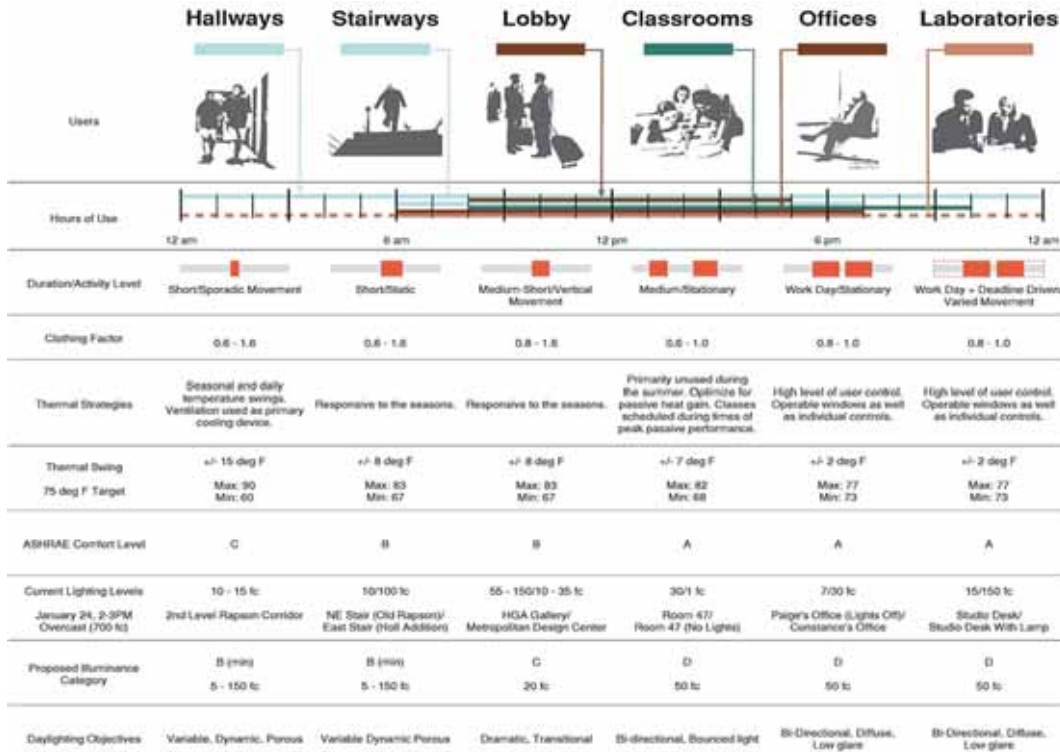

Figure 2: Example Daylight and Thermal Program (Anton, Bussey, Green, Ennon). Source: (Abraham/Weber, 2013).

3.2. Minimize loads: passive priority

Using the *Architecture 2030* energy and carbon performance metrics as a baseline, students are then asked to investigate, through design testing and parametric analyses of daylighting, thermal, and energy, how much they can reduce energy consumption from “today’s *Architecture 2030* target” while maintaining visual and thermal comfort and design excellence. Students begin by minimizing loads through the use of “architectural strategies” such as passive solar heating, natural ventilation, and daylighting, space use, and programming. Working in teams, they use a sequence of exercises that investigate site and bioclimatic forces to develop three architectural proposals shaped by daylight, passive heating, and natural ventilation.

The design projects have varied from a 20,000 square-foot “Zero Energy Lab” to a 40,000 square foot “Student Health Center” on the University campus. The initial design and performance goal is not necessarily to achieve “net-zero or beyond,” but to understand how architectural design, passive strategies, comfort, and energy decisions are interrelated. Students are introduced right away to design assessment methods and tools that evaluate the total annual energy use and carbon emissions for each of the three design proposals. In addition to daylighting and thermal analyses using *IES VE*, teams develop design proposals using physical models, traditional drawings, and diagrams. Based on the three architectural proposals, students are asked to critique the designs in comparison to the “SB2030 baseline” for energy and carbon performance as well as daylighting and thermal comfort, considering: 1) Were they able to reduce energy consumption and carbon emissions through passive strategies, architectural design interventions, and systems interventions, 2) What trade-offs and poetic, practical, and programmatic priorities influenced

design decisions, 3) What level of energy and carbon performance were met and how did they determine “how low they could go”, and 4) What strategies made the greatest impact on energy and emission while supporting overall design excellence (Figure 3).



Figure 3: Baseline and Passive Design Comparison (Abin-Fluentes, Raznik, Triggs). Source: (Abraham/Weber, 2013).

3.3. Meet energy loads: optimizing envelope and whole building design

After assessing the “passive potential” for reducing energy loads, students explore a series of exercises that help them meet the remaining energy loads using high performance envelope design integrated with heating, cooling, lighting systems. Parametric energy studies are used to explore how the design of the building envelope can be used to optimize energy performance by changing design variables such as wall construction, glazing type, insulation, window size and configuration, orientation, and shading and solar control. Each student on the team defines a “thermal hypothesis” to test through parametric analysis; for example, “Hypothesis 1: The orientation of the window does not affect energy performance in a building over 20,000 square feet in this local cold climate;” “Hypothesis 2: Roof insulation is the most important construction factor for energy performance and thermal comfort;” “Hypothesis 3: Daylighting can be integrated with passive solar to meet seasonal lighting and cooling loads without compromising visual and thermal comfort.” Students then conduct parametric analyses to incrementally reduce energy and optimize performance and comfort (Figure 4). Physical models and annotated drawings complement the quantitative assessment to illustrate broader aesthetic and experiential design concepts.

A series of “whole building design revisions” are then developed to assess how the envelope and construction details influence annual energy loads and carbon emissions. Thermal and visual comfort studies illustrate the percentage of satisfied occupants while annual monthly heating and cooling loads for

each “whole building design revision” are compared to the *SB2030 Baseline* for energy loads and carbon emissions (Figure 5). In addition to energy and comfort studies, students use more traditional drawings, physical models, and diagramming to explore overall architectural design concepts. At this mid-way point in the design exploration, students have gained confidence in working with IES VE as a “design tool” for daylighting, thermal, and comfort analyses. The “whole building assessment” is followed by studies of “one important room” using a sequence of physical models to assess the quality of daylighting and thermal comfort through the seasons. Time-sequence photographs of physical day-lighting models are used to investigate the relationship between the luminous quality and visual and thermal comfort. Parallel seasonal illuminance studies, daylight autonomy, and thermal comfort analyses complement the qualitative physical model studies. These experiential studies are a springboard to the final renewable and mechanical systems integration and design synthesis (Figure 6).

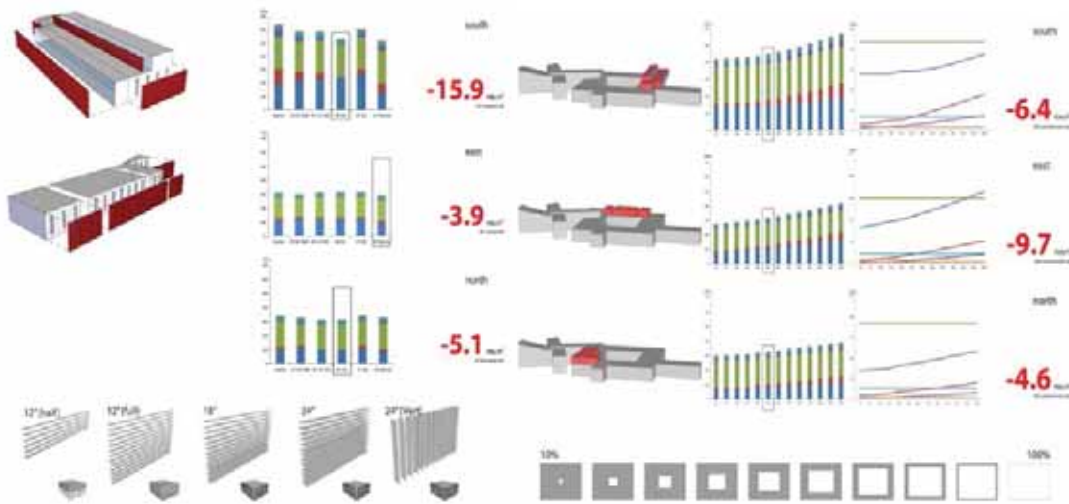

Figure 4: Envelope Optimization (Deveau, Koslovski, Partridge, Salehashafa). Source: (Abraham/Guzowski 2014).

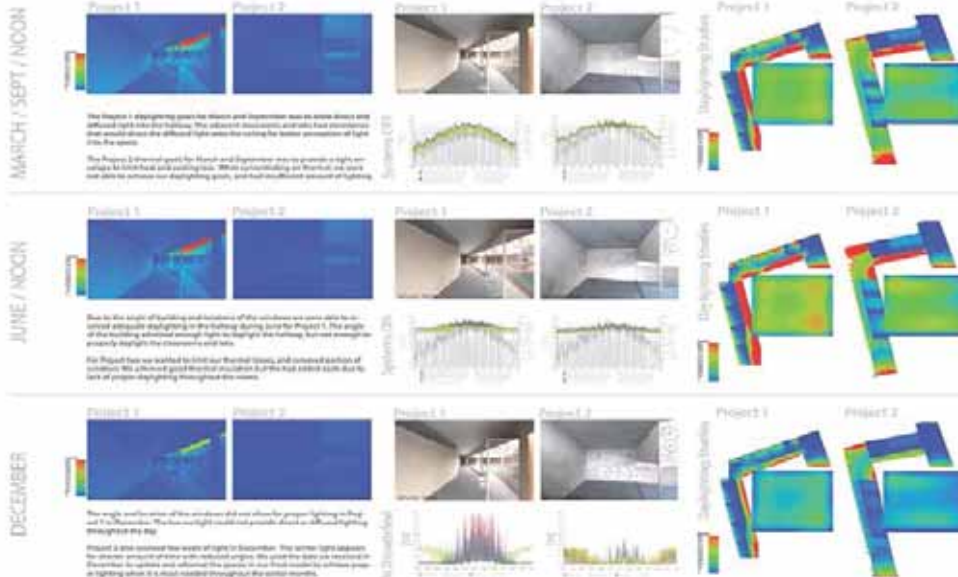

Figure 5: Daylighting and Thermal Comfort Optimization (Kopp, Hourey, Daley, Ghanbari). Source: (Abraham/Guzowski 2014).

3.4. Use renewable energy and non-fossil fuel sources: systems integration and synthesis

The final phase of the design exploration considers the integration of appropriate renewable energy and fuel sources, including solar thermal, photovoltaic, geothermal, and wind. Students are asked to use the qualitative and quantitative design methods and tools to develop a final net-zero design proposal integrating daylighting, thermal comfort, energy, and carbon emissions. In order to estimate and compare the total energy consumption and carbon emissions, students are provided with a carbon calculator. During the past several years the course has used the *Zero+ Calculator* tailored to the climate, building program, and square footage (developed with research funding from the University of Minnesota). The *Zero+ Calculator* is an

Excel-based spreadsheet that allows for the aggregation and integration of simulation results from IES VE into a set of graphs to illustrate the integrated energy performance and carbon footprint.

Final projects are presented using physical massing and detail models, traditional design drawings (plans, sections, elevations), diagrams, experiential images (renderings and renderings and daylight model photographs), and final quantitative analysis of the energy performance and carbon emissions (*Energy Consumption in kbu/SF/Yr* and *Carbon Footprint in lbs/SF/Yr*). Teams are asked to critique the final proposal using the following questions: 1) *Design Intentions, Concepts, and Strategies*: Summarize the critical design intentions, concepts, and strategies related to daylight, thermal, and zero-energy design, 2) *Net-zero Energy Performance*: State clearly how well your final design meets your net-zero energy performance goal using written and graphic means, 3) *Carbon Emissions*: State clearly how well your final design performs in terms of annual carbon emissions using written and graphic means, 4) *Ecological Impacts/Benefits*: Summarize the ecological benefits of your final design to the community and surrounding eco-systems; and 5) *Strengths, Trade-offs, and Lessons*: Critique the final design decisions, priorities, and trade-offs (Figure 6). For detailed syllabi, exercises, and information on the design outcomes of the student projects, please see the *Zero+ Campus Design Project*: <http://zeropluscampus.umn.edu/courses/thermalandluminous.php>.

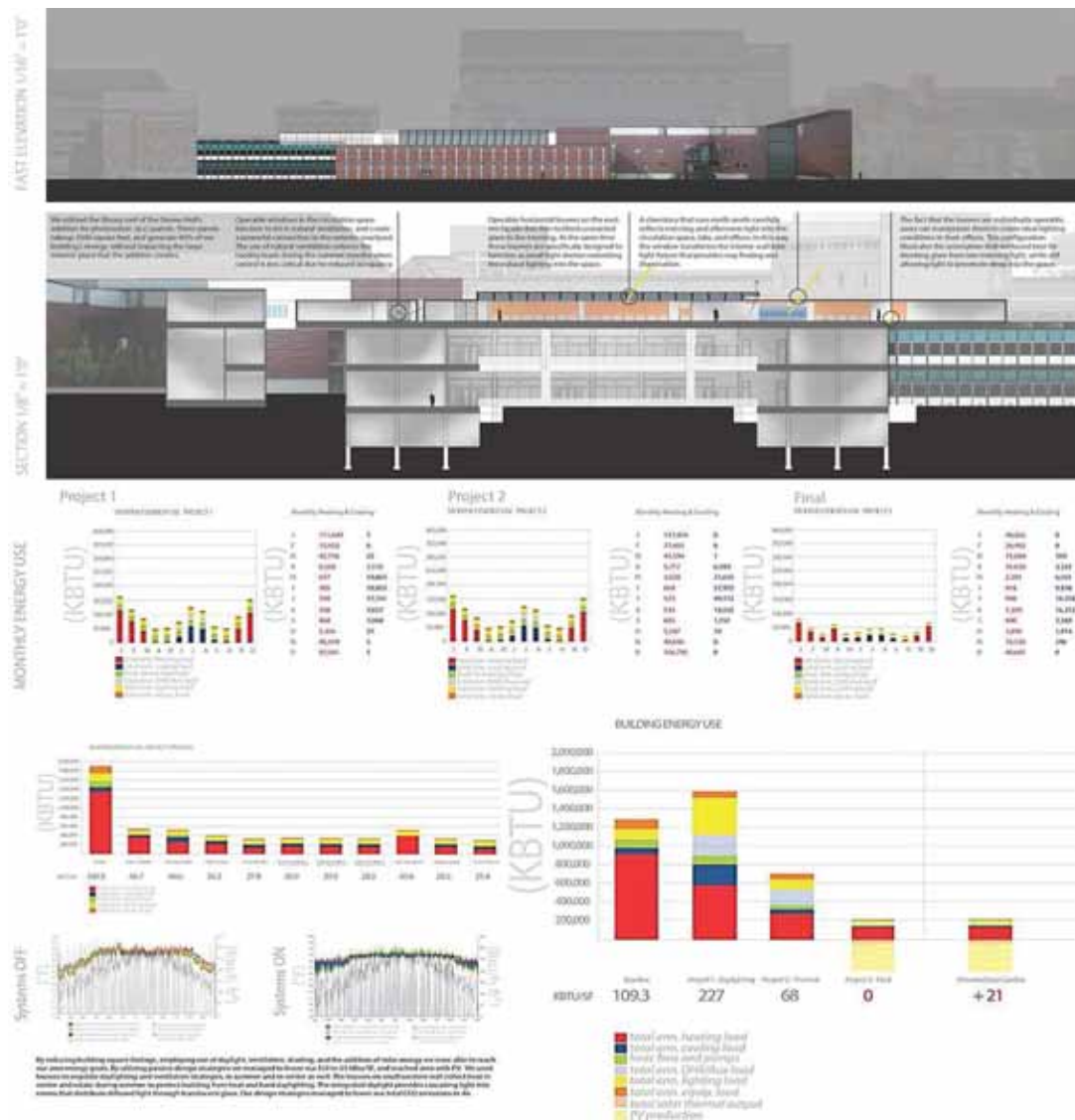

Figure 6: Whole building analysis compared to baseline (Kopp, Hour, Daley, Ghanbari). Source: (Abraham/Guzowski 2014).

CONCLUSION

This net-zero architecture course asks students to explore the relationships between luminous and thermal design and to consider a fresh perspective on the roles of “passive design” and “solar architecture” in reaching net-zero energy in cold-climate architecture. Net-zero design protocols integrate essential solar

principles and precepts (such as attention to building orientation, appropriate room depth and height, methods of solar control, effective material characteristics and colors, and responses to seasonal change); state-of-the art technologies, and innovative approaches to building programming and use. The integration of poetic and pragmatic considerations is a distinguishing feature of the most innovative and elegant design approaches to net-zero energy and carbon-neutral architecture; revealing that it is possible (and necessary) to respond to urgent ecological challenges with beautiful and meaningful architectural experiences. Students are encouraged to consider how net-zero architectural expressions are diverse and open to creative interpretation. As Architect and sustainable design expert Mario Cucinella argues, energy and carbon are at the heart of good design: “*There is an aesthetic in carbon-neutral design, in beautiful buildings. The future of sustainable design is not about more photovoltaics. In the future of building, we need more work on the quality of space and integration of solar and carbon-neutral design so that it is part of the process—so that the shape of the building solves the problem*” (Guzowski, 191).

Nearly a decade after the *Architecture 2030 Challenge* was launched, high-performance design strategies and mechanical systems have enable practitioners to meet today’s targeted fossil-fuel reductions of 60%. Achieving the remaining 70-100% reductions will require new ways of approaching architectural design, passive and bioclimatic strategies, programming, and occupancy that go beyond our current models of energy efficiency and systems integration. The following suggestions distilled from the course should be helpful for those considering development of a net-zero design curriculum:

1. *Establish partnerships between practice, research, and the academy:* Diverse expertise is needed to design a net-zero curriculum, including energy and technical expertise as well as experience in curriculum development. Given the complexity of the issues and design methods, it is essential to establish a faculty cohort with complementary strengths in practice, research, and teaching.
2. *Foster administrative awareness and support:* A demonstrable and sustained commitment is needed to develop, test, and refine a net-zero curriculum. Take time to educate administrators about the challenges and opportunities of creating a curriculum in this emerging area. Dedicated resources and time will be needed to assess existing resources, master new tools, and develop resources and tutorials for students. Given their evolving nature, sustained support is particularly needed for computer tutorials and digital resources.
3. *Relax with creating the path as you go:* Acknowledge that there is a lack of clarity in the design education community regarding common net-zero goals, metrics, and protocols. Invite students into the dialogue and foster an atmosphere of curiosity and exploration, while acknowledging the emerging nature of the topic.
4. *Teaching and learning a process:* Emphasize the value of learning iterative and parametric design processes and methods that enable designers to balance quantitative performance goals with qualitative and experiential design intentions. Students weigh their individual design priorities and ecological values as they reconcile the project goals and energy performance with potential design strategies and trade-offs.

ACKNOWLEDGEMENTS

The author gratefully acknowledges the support of the School of Architecture and the University of Minnesota in providing resources to develop teaching models, methods, and tools. Many colleagues and students were involved in the development of course materials, resources, and tutorials, including teaching colleagues Loren Abraham, Jim Lutz, Ian McLellan, Jeff Niemasz, and William Weber; Dr. Ilene Alexander from the Center for Teaching and Learning; and graduate students in the M.Arch program.

REFERENCES

- Architecture 2030, January 2006, *The Architecture 2030 Challenge and 2010 Imperative*, Santa Fe, New Mexico: Architecture 2030, <http://www.architecture2030.org/>.
- Dorn, Whitney. “The Net-Zero Energy Challenge: Who Will be Next,” US Green Building Council (USGBC), <http://www.usgbc.org/articles/net-zero-energy-building-challenge-who-will-be-next>.
- International Living Futures Institute, 2014, *Living Building Challenge*, Seattle, WA, <http://living-future.org/lbc>.
- Guzowski, Mary. *Towards Zero-Energy Architecture: New Solar Design*, London: Laurence King Ltd., 2010.
- Lazarus, Mary Ann, October 2013, *Sustainability Leadership Opportunity Scan*, Washington DC: American Institute of Architects, <http://www.aia.org/practicing/AIAB100307>.
- State of Minnesota, 2014, *Sustainable Building Guidelines and SB230 Energy Calculator*, <http://www.b3mn.org/guidelines/>.
- National Architectural Accreditation Board (NAAB), July 2009 and August 2013, *2009 and 2014 Conditions for Accreditation*, Washington, DC: NAAB, http://www.naab.org/accreditation/2009_Conditions.
- Society of Building Science Educators, <http://www.sbse.org/>.
- Wasley, Jim and Terri Meyer Boake, Mary Guzowski, and John Quale, 2010, *Carbon Neutral Design Project*, Society of Building Science Educators, <http://www.tboake.com/carbon-aia/>.
- Zero+ Campus Design Project*, 2014, University of Minnesota, <http://zeropluscampus.umn.edu/>.

Passive House informed: The next level of energy efficiency in affordable housing

Amanda Donofrio¹, Mike Magee¹, Julie Romig¹

¹Bergsund DeLaney Architecture & Planning, Eugene, Oregon

ABSTRACT: In 2012, Bergsund DeLaney Architecture and Planning (BDA) designed an affordable housing community for St. Vincent DePaul Society of Lane County (SVdP) that included two six-unit buildings with identical floor plans and orientation, each constructed to a different sustainability standard: Passive House and Earth Advantage. Research groups from the University of Oregon School of Architecture (UO) conducted two studies, one that analyzed life cycle decisions made in the early design process and another that monitored and analyzed energy use post-occupancy. All of the research conducted by the UO was made available to the project team for review and use. The research has proved valuable not only to validate and support the decisions made during the design and construction of the Passive House, but also to inform future building design. This paper presents a framework to review the strategies used in the two case study buildings and determine recommendations for Passive House informed construction.

KEYWORDS: Passive House, Affordable Housing, Energy Efficient Design, Research Collaboration

INTRODUCTION

Affordable housing programs exist to subsidize tenant rent and assist low-income individuals and families from becoming house poor, but tenants are typically responsible for the cost of their utilities. As energy costs continue to increase, energy efficient design in affordable housing has become a high priority for owners looking to pass utility saving onto tenants. Over the past decade, funding for affordable housing has required participation in green building certification programs as a way to confirm a commitment to energy efficient design. As funding for affordable housing becomes more competitive, developers are willing to commit to higher levels of energy efficiency in order to stand out in applications for funding. In the Oregon, the most commonly used certification program is Earth Advantage.

In 2012, during the design process for a multi-unit affordable housing project Bergsund DeLaney Architecture and Planning (BDA) and St. Vincent DePaul Society of Lane County (SVdP) were approached to consider certifying one building in a multi-building project to Passive House standards. Due to a higher than expected return on awarded tax credits, the team was able to conduct a pilot project comparing two six-unit buildings with identical floor plans and orientation constructed to two different sustainability standards: Passive House and Earth Advantage. The Owner, Architect and General Contractor (Meili Construction) worked closely with a team of Passive House consultants to determine what strategies would be utilized for the Passive House building. The strategies proposed by the Passive House consultants and the Architect were weighed against constructability concerns brought forth by the General Contractor and operations and maintenance concerns represented by the Owner. The intent with the construction methods for the Passive House was to be as similar as possible, to typical multi-family affordable housing construction practices utilized in the Pacific Northwest.

1.0 RESEARCH RELATIONSHIP

Multiple research groups from the University of Oregon School of Architecture (UO) approached the project team about conducting studies to analyze life cycle decisions made in the early design process as well as monitor and analyze energy use once construction was complete. All of the research conducted by the UO teams has been made available to the project team for review and use. The research has proved valuable not only to validate and support the design and construction of the Passive House, but also to inform future building design.

This unique relationship between the University, a small architecture firm and a non-profit client results in a mutually beneficial research feedback loop. The UO research groups benefit from the ability to collect and analyze data from a tangible project while the architecture firm and the client benefit from research the team would not be able to otherwise afford to conduct or commission. The research collected and shared has increased the rigor with which the owner-architect team questions energy efficiency strategies and provides a basis to compare potential strategies against for Passive House Informed construction.

The first research study was a Life Cycle Assessment (LCA) commissioned by the City of Eugene with Eugene Water and Electric Board (EWEB), the local utility provider, in an advisory role. Both the City and EWEB financially supported the Passive House case study in various ways, including a financial contribution to the energy monitoring equipment installed in both case study buildings. The LCA was conducted shortly after the schematic design phase. The intent was to determine the environmental life cycle impact of the additional materials added to the building to meet the Passive House standard and

to ensure that improved construction (such as increased insulation) can be 'paid back' in increased building efficiency instead of inadvertently shifting the environmental burden from the use phase to the construction phase with no overall lifecycle environmental savings (Moore 2011, 2).

The results of the study showed that,

even though there are significant environmental impacts associated with the additional construction materials for a Passive House upgrade, these impacts would be offset by the increased building efficiency (Moore 2011, 1).

The second study conducted is in progress and is a two-year data collection and analysis comparing the energy usage between the constructed Earth Advantage and the Passive House buildings. A report of the energy lessons from the first year has been recently prepared and issued to the Owner. In the first year, the data collected has shown that the

Passive House units used 59% less *heating* energy than the Earth Advantage units; we assume that this translates into approximately 63% better than (the Oregon Energy Efficiency Specialty) code (Kwok 2014, 6).

An interesting result from the first year lessons is that the Passive House uses 36% less *total* energy than the Earth Advantage building. The target savings anticipated for the Passive House is 60% better than Earth Advantage. The conductors of the study feel that "occupant behavior is a strong factor in the energy usage" (Kwok 2014, 13). During the second year of the study they hope to ascertain if "occupant knowledge and awareness of how Passive House and Earth Advantage buildings function and their specific goals may help to further lower energy consumption of the high performance buildings" (Kwok 2014, 13).

2.0 LESSONS LEARNED

The Owner, General Contractor, Architect and Passive House consultants met for a debriefing session six months after project completion. The purpose of the meeting was to determine if the Passive House standard was appropriate for affordable housing. While acknowledging the utility cost savings to the tenants, the team also discussed the 30% difference in initial construction cost between the Passive House case study building and the Earth Advantage case study building. When faced with the choice of developing more units of housing to a level of efficiency still exceeding code or building fewer units of housing that are Passive House certified, the Owner decided that they cannot justify the added construction cost of Passive House. This reality, that meeting Passive House standards is not financially feasible on future projects, has inspired the establishment of a framework to review the strategies most applicable for Passive House *informed* construction.

The data collection and analysis has shown that the energy savings for Passive House construction is real and that it is significant. The project team recognized increased affordability for tenants via lower utility bills was a primary reason for participating in the Passive House case study. With this information at hand, the Owner plans to commit to many Passive House design and building techniques going forward. For example, the team benefitted from the opportunity to learn how to work with continuous exterior insulation, anticipating that it will eventually be a code requirement (as of the release of the 2014 Oregon Energy Efficiency Specialty Code (OEESC), it is still not required) and will include this insulation in future projects. The team also agreed to continue pursuing enhanced air sealing on future projects. While the General Contractor admitted that the enhanced air sealing measures, especially around the windows, was one of the biggest challenges with a steep learning curve, they feel that they could anticipate a significant labor savings if the process was repeated in the future because of what was learned on the case study project. The General Contractor identified HVAC as the biggest cost challenge to the project. The ERV system used came with increased complexity to meet the Passive House certification requirements, which was a disincentive to the Owner and the General Contractor for using an ERV system in the future.

3.0 PASSIVE HOUSE INFORMED FRAMEWORK

The analysis of the strategies used in the Passive House case study building (PH) and Earth Advantage case study building (EA) case study building (Fig. 1) guided the Passive House Informed Framework (PHIF). The case study experience impressed upon the team that the passive elements of high performance building are the most beneficial in multi-unit affordable housing and this principle influenced the creation of the Passive House Informed Framework. It is organized in a manner similar to the Passive House Institute's

principles. The categories include: insulation and reduced thermal bridging; air sealing; air exchange; high performance windows and solar gain.



Figure 1: Passive House case study building (left), Earth Advantage case study building (right).

3.1. Insulation and thermal bridging

The insulation specified at the Earth Advantage (EA) case study building (Table 1) included blown-in blanket insulation in 2x6 stud walls at 24" (60.96 cm) on center (R-23), 16" (40.64 cm) of glass fiber loose fill insulation in the ceiling (R-49) and the 11-7/8" (30.48 cm) truss joists at 24" (60.96 cm) on center filled with batt insulation (R-38). Rim joists and headers were insulated with 2-1/2" (6.35 cm) of EPS - Expanded Polystyrene insulation (R-11).

At the Passive House (PH) case study building (Table 1), the same blown-in blanket insulation was used in the 2x6 stud walls at 24" (60.96 cm) on center (R-23) and the rim joists and headers were insulated with 2-1/2" (6.35 cm) of EPS (R-11). These were the only areas with the same insulation levels at the case study buildings. The ceiling was insulated with 27" (68.58 cm) of glass fiber loose fill insulation (R-84), the 11-7/8" (30.48 cm) truss joists at 24" (60.96 cm) on center were filled with glass fiber loose fill insulation (R-50) and the entire building was covered with 4" (10.16 cm) of Exterior Rigid Polyisocyanurate continuous insulation (R-27) (Fig. 2). Additionally, the concrete stem wall foundation was insulated from the exterior with 4" (10.16 cm) of EPS (R-18) and from the interior with 3" (7.62 cm) of EPS (R-13.5).



Figure 2: Continuous insulation over WRB on PH (left), siding directly over WRB on EA (right).

The value of super insulating buildings is clear from the energy monitoring information collected from the case study buildings. The Passive House Informed (PHIF) buildings currently under construction have

increased insulation. The insulation values are scaled back from the Passive House standards in some areas and in some areas remain the same as in the Earth Advantage case study building (i.e. the crawl space).

Blown-in blanket insulation is used in the PHIF 2x6 stud walls at 24" (60.96cm) on center (R-23). Continuous insulation has been added to the exterior of the building to reduce thermal bridging (Fig. 3). An advanced framing strategy takes advantage of the rim joists at the edge of the floor framing for window and door headers; this allows the full wall thickness of insulation above windows and doors. Smegal and Straube provide further justification for this assembly.

The use of 1" thick insulation at the exterior side... does not significantly alter the constructability of the wall. The use of thicker layers of exterior insulation... (i.e. thickness > 1") tends to increase the complexity of detailing around windows, doors and other penetrations through the wall (Smegal and Straube 2010, 35.)

During the preparation of construction documents, the team determined 1" (2.54 cm) of rock wool continuous insulation would work without modification to the firm's standard window detail. Rock wool insulation was recommended by Walsh Construction Co., a Pacific Northwest based general contractor with significant green building experience in the region, because 1" (2.54 cm) thickness the is still breathable in the event that moisture gets into the wall. While on site for the PHIF window mock-up, the window and door detail was modified in such a way that it could grow to accommodate additional inches of continuous insulation for future projects.



Figure 3: Continuous insulation over WRB on PHIF.

The PHIF roof/ceiling assembly is composed of roof trusses at 24" (60.96 cm) on center with 5/8" (1.58 cm) Type X gypsum board attached to the bottom of the roof trusses. In the Passive House (PH) case study building, a layer of 1/2" (1.27 cm) plywood was added between the roof trusses and the gypsum board to support the additional weight of the R-80 glass fiber loose fill insulation. The project Structural Engineer determined that 19-1/2" (49.53 cm) of loose fill insulation (R-60) can be supported by the gypsum board ceiling without adding an additional layer of plywood, creating a PHIF assembly that is sufficiently insulative without adding extraneous material (Table 1).

Table 1: Insulation R-values.

	<i>PH</i>	<i>EA</i>	<i>PHIF</i>	<i>OEESC</i>
<i>Attic (Flat Ceiling)</i>	R-84	R-49	R-60	R-38
<i>Walls (Cavity)</i>	-	R-23	-	R-21
<i>Walls (Continuous)</i>	R-23+R-27ci	-	R-23+R-4ci	R-13+R-3.8ci
<i>Raised Floor</i>	R-50	R-38	R-38	R-30
<i>Exterior Stem Wall</i>	R-18	-	-	-
<i>Interior Stem Wall</i>	R-13.5	-	-	-

3.2. Air sealing

At the Earth Advantage (EA) case study building, a weather resistive barrier system was used over the plywood and an air sealing checklist was developed in house to meet the requirements of the Energy Star Thermal Bypass checklist required for Earth Advantage certification. The blower door test was conducted for

the whole EA building and resulted in 3.5 air changes per hour (ACH) when tested at 50 pascals, exceeding the required 6 ACH. Foam and caulk were the most frequently used materials to fill any gaps around penetrations in the EA building shell. The Passive House (PH) case study building functioned as a six-sided box with plywood at the walls, ceiling and crawl space taped at the seams to serve as the air barrier (Fig. 4). The PH building exceeded the required 0.6 ACH and tested at 0.5 ACH @ 50 pascals for the whole building. Tape was used most frequently to address any penetrations in the PH building shell.



Figure 4: Taped plywood seams throughout PH.

The General Contractor self performed all of the air sealing at the Passive House and the Earth Advantage case study buildings. Air sealing has been handled in various ways on different sites throughout the years. The article *Air-Sealing Tips and Tricks* states “you can’t count on crew members or subs to do their own air-sealing as the job moves along. There has to be someone on the job who oversees all of the trades to make sure the air-sealing gets done, and who is willing to give this role the focus and attention to detail it requires” (Nordbye 2012, 25). At the case study building, the effectiveness of air sealing was related to the control the GC took over the measures. Since this is a means and methods item, the most beneficial thing an Architect can do is devote a pre-construction meeting to the importance of air sealing.

In the Passive House Informed Framework (PHIF) buildings currently under construction, an air barrier house wrap system is used as the WRB. The seams of the house wrap are taped to serve as an air barrier at the exterior walls with a tape from the air barrier manufacturer (Fig. 5). The plywood seams could be taped to meet the same goal. At the Passive House (PH) case study building, the tape recommended by the Passive House consultants was a high quality imported tape. It was very expensive for the quantity used and therefore is not being used on the buildings currently under construction.



Figure 5: Air barrier house wrap with taped seams at PHIF.

In the Passive House (PH) case study building all penetrations through the roof/ceiling assembly were eliminated and all light fixtures, fire sprinklers and smoke detectors were moved onto the interior walls. This presented multiple challenges related to conventional construction methods and trade experience with typical roof/ceiling penetrations. The next big challenge anticipated is to address treating the ceiling as an air barrier.

During the debrief after the case study was complete, the General Contractor informed the team that conducting the blower door test for the whole building after drywall was installed was very difficult with the extremely low target for air changes. The General Contractor felt that air sealing at the party walls and testing unit by unit would've made the process easier. To meet the Passive House certification standard, a larger box is a more efficient box and therefore the party walls received no additional air sealing. At a project concurrent with the case study buildings by the same architects, the seams at the plywood sheathing were taped on the exterior walls and foam and caulk was used at each party wall in a multi-unit building to treat each unit as a small box. Though the project had no continuous insulation, the resulting blower door test results ranged from 2.9-3.5 ACH50. The team anticipates even better test results from the PHIF buildings currently under construction.

3.3. Air exchange

The result of building tighter buildings is that fresh air needs to be introduced and stale air exhausted. At the Earth Advantage case study building, trickle vents in windows were used to introduce fresh air paired with a continuous running exhaust fan in the bathroom to exhaust stale air. At the Passive House case study building, an energy recovery ventilator (ERV) was used to bring in fresh, filtered air and exhaust stale air with 96% heat recovery efficiency (Fig. 6). For the Passive House case study building, there were only two approved ventilation units available in the country. To use anything else would have incurred a 15% devaluation from the manufacturer's claimed efficiency and put certification out of reach. Once installed, balancing the ERV proved complicated because factory pre-sets needed to be overridden so that the equipment ran at lower rates than the lowest available setting.



Figure 6: ERV at PH (left), examples of passive air inlets (center), trickle vent at window head at EA (left: Kwok 2014, center and right: Author 2013).

In the past, the problem seen with trickle vents at windows is that tenants will tape over the vents to prohibit the 'draft' at the window and therefore override the fresh air coming into the unit. Given the cost and complexity that came with balancing the particular ERV to meet the Passive House standard, the Owner is prejudiced against using this additional piece of mechanical equipment in the immediate future. The Passive House Informed Framework (PHIF) buildings are using two passive air inlets (Fig 6) per dwelling unit paired with trickle vents in bedroom windows to supply fresh air and rely on the continuous running bathroom fan for exhaust.

It is important to note that in the Oregon climate heat recovery ventilators (HRV) could effectively be used but that for the Passive House (PH) case study building an ERV was required based on model inputs and trade-offs. The Architect is investigating the use of HRVs and ERVs at upcoming projects.

3.4. High performance windows and solar gain

At the Earth Advantage case study building, a double glazed vinyl window was used throughout. The windows were either single hung or fixed and had an average u-value of 0.29 and a solar heat gain coefficient (SHGC) of 0.29. At the Passive House building, a triple glazed fiberglass window was used throughout. The windows were either casement or fixed and had an average u-value of 0.21 and a SHGC of

0.50. Sunshades over the windows on the south and east facades provide shade in the summer and allow for passive solar to enter the building in the colder winter months. The windows in both of the case study buildings were from Pacific Northwest based manufacturers.

As part of the debriefing session with the General Contractor, the team learned that the windows were one of the top three areas for increased cost and difficulty in the Passive House building. The first year results at the Passive House (PH) case study building show that the Earth Advantage case study apartments are kept approximately 2°F warmer than the Passive House units. The study speculates that less thermal stratification in the Passive House units and less air leakage resulting in less draft are factors in the difference (Kwok 2014). The triple-glazed casement windows would likely contribute to the improvement in both cases. The Architect feels that money spent on better windows is in line with the concept of focusing on the passive elements of high performance buildings but our owners and contractors are not ready to make the change to triple glazed windows. The Passive House informed buildings currently under construction will have single hung, double-glazed, vinyl windows and a u-value of 0.25.

Joe Lstubrick advises against passive solar, instead “you should do very, very low SHGC’s, around 0.2, in your glazing” (Lstubrick 2014, 2). The SHGC’s in the windows used at the Passive House Informed Framework buildings are 0.29, even with the improved u-value. As this region is not a cooling climate, there is not a great benefit from super low solar heat gain coefficient glazing.

CONCLUSION

In 2014, Stellar Passive House Apartment Building in Eugene, Oregon became the first multi-unit affordable housing project to be certified by Passive House Institute US and the entire project team was excited to learn from this unique opportunity. The experience has changed the way that all of the parties look at energy efficiency in affordable housing. In response to the question of whether it makes financial sense to build to the Passive House standard for affordable housing, the team has concluded that it does not. The team agrees that it is important to continue building increasing energy efficiency in a cost and material efficient manner.

One of the most important aspects of this experience is that data is being collected from the case study buildings, analyzed by a third party and shared with the project team so that all parties benefit from the application of research and applied knowledge. The first Passive House Informed Framework project is under construction by Meili Construction for St. Vincent de Paul in Eugene, Oregon and includes a building type with a similar design to the Stellar Apartments case study buildings. It is the hope of the Architect that the same energy monitoring equipment will be installed in the first PHIF buildings so that the impacts these measures have on energy savings can be compared across like projects and further inform future strategies.

ACKNOWLEDGEMENTS

Bergsund DeLaney Architecture & Planning, P.C. owes a great deal to St. Vincent de Paul Society of Lane County and Meili Construction for their willingness to continue to build better buildings. We are grateful to our Passive House consultants: Jan Fillinger, Win Swafford and Peter Reppe; Alison Kwok of the NetZED Laboratory at the Department of Architecture, University of Oregon; and Erin Moore at the Department of Architecture, University of Oregon for sharing research and knowledge. We appreciate the support of the City of Eugene and EWEB in commissioning research studies and providing support for energy monitoring equipment.

REFERENCES

- Kwok, Alison. 2014. *Annual Report: Stellar Apartments for St. Vincent de Paul Society of Lane County September 2013 – August 2014.* Report, University of Oregon NetZED Laboratory.
- Lstubrick, Joseph. 2014. *Zeroing In: Net Zero Houses.* Building Science Insight-081, <http://www.buildingscience.com/doctypes/insights>
- Moore, Erin. (2011). *Passive House LCA Report.* Report, University of Oregon.
- Nordbye, Terry. (2012). *Air-Sealing Tips and Tricks.* *Journal of Light Construction.*
- Smegal, Jonathan and Straube, John. (2012). *High-R Walls for the Pacific Northwest – A Hygrothermal Analysis of Various Exterior Wall Systems.* Report, Building Science Corporation.

Quantifying the impact of passive design on high rise buildings

Mohamed A. M. Krem¹, Simi T. Hoque², Sanjay R. Arwade³

¹Department of Civil Engineering, Al-Mergeb University, Al-Khoms, Libya

²Department of Environmental Conservation, UMass-Amherst, MA

³Department of Civil and Environmental Engineering, UMass-Amherst, MA

ABSTRACT: Buildings account for over 40% of all U.S. energy use (DOE 2012). This has an impact on national energy security, the economy, and the global environment. Provisions for local, state, and national building energy standards/codes exist to promote energy efficiency, making such codes a central part of the green building movement. These efforts are augmented by the architecture, engineering, and construction (AEC) industry through passive design strategies, advanced construction techniques, and the application of renewable energy technologies. This paper analyzes the sensitivity of operational energy use to variations in footprint aspect ratio and building orientation, both of which are critical design strategies for passive heating and cooling. Four identical high-rise office buildings are simulated in each of the four major climate zones (cool, temperate, arid, and tropical). All buildings are 200 meters in height, 50 stories that are 4.0 m floor-to-floor height, with a total conditioned floor area of 135,000 square meters. Preliminary energy analysis is performed using Autodesk *Ecotect Analysis* 2011, and the results are validated using the Department of Energy's *eQuest* version 3.65 building simulation software. The buildings were modeled to comply with the International Energy Conservation Code 2009. The results suggest that design strategies to maximize passive thermal conditioning and daylighting do little to reduce the load profiles of high-rise office buildings built to current energy codes.

KEYWORDS: Site Layout Planning, Orientation, Passive Solar Design, High Rise Buildings, Sustainable

INTRODUCTION

Global warming and climate change are major challenges facing the nation and the world. More than two thirds of the electricity energy and one third of the total energy in the US are used to heat, cool, and operate buildings (DOE 2012). The combustion of fossil fuels to supply energy to commercial buildings resulted in the emission of 1,075 million metric tons of carbon dioxide (CO₂) in 2008. This represented roughly 17% of all U.S. CO₂ emissions in that year (EPA/OAP 2009). A reduction in building energy consumption may help to mitigate these critical issues.

Building energy codes are intended to promote energy efficiency (DOE 2012). The reduction in energy use may translate to a financial savings that can be achieved through the development of new technologies (for the building's envelope, mechanical, and lighting systems) that save energy and reduce CO₂ emissions (Crawley, Pless et al. 2009; Hoque 2010). The benefit to the building owner is lower monthly utility expenses, and smaller less expensive HVAC equipment (Harvey 2009). An alternative approach is the use of passive systems that employ renewable energy sources. Passive systems avoid the need for heating or cooling through better design, construction, and operation. They utilize solar or wind energy to heat, cool, or light buildings. While passive systems are relatively uncommon for large commercial buildings, hybrid mixed mode approaches may be effective in reducing the overall energy loads of conventional office buildings (Brager, Ring et al. 2000). High rise office buildings, which are the focus of this study, are well known to be "internally load dominated" buildings, which means that the operational loads (heating, ventilation, cooling, lighting, and space equipment) within these building types drive their energy profiles (Al-Homoud 1997). A building's size, use, vintage, and geographic region are among the key determinants that influence its energy use. Almost all US office buildings are conditioned with mechanical heating, ventilating, and air-conditioning (HVAC) systems and overall energy use is dominated by electric lighting loads (Pérez-Lombard, Ortiz et al. 2008). In fact, mechanical cooling and lighting energy use account for approximately 35% of commercial building electrical consumption in the United States (Figure 1), which has drawn attention to the concept of integrating passive heating, ventilation and natural daylighting in conventional office buildings (Li and Lam 2001).

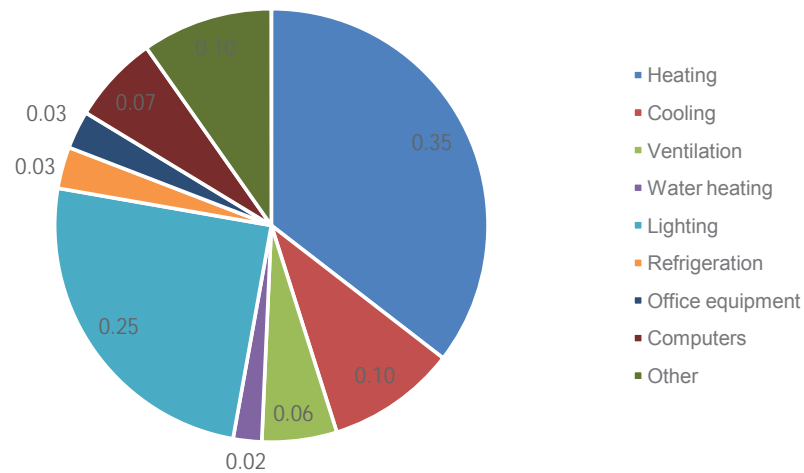

Figure 1: End Use Energy Consumption of Office Buildings in the US. Source: (EIA 2008)

Recent developments in high performance building are beginning to transform the way commercial office buildings are conceived and designed. For instance, the first Passive House Standard certified office building in the world has been constructed in Vienna, Austria. The Raiffeisenhaus Wein.2, or RHW.2 office tower, completed in December 2012, is 73 meters high and contains 18,600 square meters of office space (Meyer 2013). The design meets PHS in three critical ways: the thermal efficiency of a super-insulated double facade, the use of daylight to reduce electrical lighting requirements, and the advanced mechanical systems. Heating is primarily passive using solar gain, equipment loads, and occupants, supplemented by a geothermal heat pump. Cooling, which is only 8% of the energy loads, is a mixed mode system, using a combination of natural ventilation and mechanical cooling from the heat pump.

In the present study, we analyze the sensitivity of energy demand to two parameters of passive design related to building layout and site orientation. The key parameters we investigate are building footprint aspect ratio and the building orientation and are considered important factors in passive design (Yeang 1999; Yeang 2002). Four conventional (glazed curtain wall) high-rise office buildings with four different aspect ratios are simulated in four major Koppen climate zones: cool, temperate, arid, and tropical (Rubel and Kottek 2010). Energy demand is calculated for each model with respect to two opposing orientations. The four high-rise buildings are modeled to meet International Energy Conservation Code 2009 requirements, which references several ASHRAE standards, including Standard 90.1 for commercial building construction (IECC 2009).

Previous studies have shown potential for building site layout planning to play a positive role in influencing energy demand. For example, in *The Green Skyscraper* (1999), Kenneth Yeang suggests that in different climate zones the shape of the building footprint and the building orientation should be modified based on the climate zone in which the building is to be constructed. In the following sections we describe the analytical method and the primary variables that will be measured against energy use in the four modeled buildings. We then summarize the results for each of the thirty-two scenarios and present our conclusions.

2.0 STUDY AREA

Four models of high-rise office buildings are considered in this study to evaluate the sensitivity of energy demands to variations in: (1) footprint aspect ratio (1:1, 1:2, 1:3, and 1:4) (Figure 2), and (2) building orientation (NS and EW) (Figure 3). Since our goal is to isolate the influence of building site layout planning on energy demand, all other buildings descriptors such as the square footage, number of stories, building height, and occupancy for the four buildings are held constant across all four buildings. The four buildings are 200 meters in height, 50 stories that are 4.0 m floor-to-floor height, with a total conditioned floor area of 135,000 square meters. We also treated the thermostat range, internal design conditions, occupancy,

infiltration rate, and hours of operation as fixed control variables (Table 1). Personal factors such as activity (metabolic rate) and clothing (insulation of clothing) are treated as constant for all building occupants.

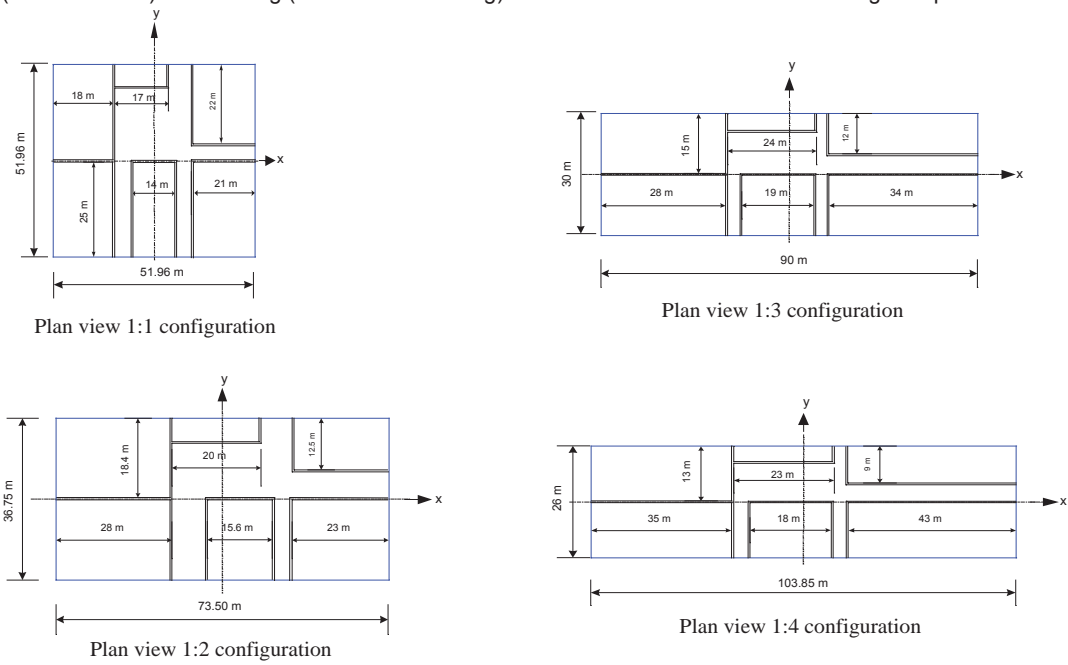

Figure 2: Footprint aspect ratios for modeled buildings in plan view.

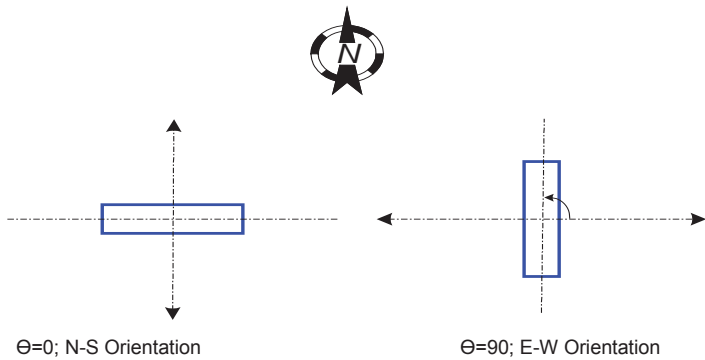

Figure 3: Building orientations considered in this study.

Table 1: Thermal analysis conditions.

Parameters		Values
Active system		Full air conditioning
Thermostat range		18 – 26 °C
Occupancy	People	12 m ² /person
	Activity	70 W/person
Internal design conditions	clothing	1 CLO/person
	Relative humidity	60%
	Air speed	0.5 m/s
	lighting level	300 lux
Infiltration	Air change rate	0.5 /hr
Internal heat gain		10 W/m ²
Hours of operation		Schedule (8:00 – 18:00)

The primary material for the envelope is a glazed curtain wall, which is comprised of two layers of standard glass with 10% metal framing. The floors are assembled layers of 10mm ceramic tiles, 5mm screed, 100 mm normal concrete, insulation (to meet the R-value specified for the climate according to IECC 2009), 50 mm air gap, and 10 mm plaster. To simplify the thermal analysis, we have ignored the effect of adjacent buildings, in essence assuming that the buildings are erected on flat open ground and are aligned with the cardinal directions.

The four buildings are simulated in each of the four major climate zones (cool, temperate, arid, and tropical) and we selected specific US cities to represent each climate zone: Boston, Massachusetts for the cool zone, Sacramento, California for the temperate zone, Las Vegas, Nevada for the arid zone, and Honolulu, Hawaii for the tropical zone. Building envelope materials are selected for all four models to meet the requirements of thermal properties of IECC 2009, corresponding to each climate zone (Table 2).

Table 2: Building envelope properties

		Envelope Properties			
		Cool	Temperate	Arid	Tropical
Element	Climate				
Curtain Wall (Glazing wall with 10% metal framing)		U=2.5	U=3.4	U=5.4	
		SHGC=0.4	SHGC=0.25		
Roof		R=3.7		R=2.7	

U-factor (W/m²K); R-value (m²K/W)
SHGC Solar Heat Gain Coefficient

3.0 ANALYTICAL APPROACH

Autodesk’s Ecotect energy simulation package was used for the preliminary thermal analysis. Ecotect 2011 is a comprehensive concept-to-detail sustainable building design program; it is a popular program used by architects, as its modeling procedure is simple, easy to manipulate, and it consumes a reasonably short run time for large models. For this study, the building geometry was prepared in Autodesk Revit 2010 and then imported as surfaces and rooms to Ecotect 2011. In Ecotect, thermal properties are assigned to the envelope. The basic material of an element (floor, roof, glazing wall, etc.) is assigned first, the thermal properties of element and the insulation is then applied according to specifications of IECC code. The next step is to assign a weather file that corresponds to the climatic zones selected for this study and to provide occupancy and scheduled usage data. Ecotect calculates the overall heat gain/loss, and based on Flat Comfort Bands Method (FCBM), the heating & cooling loads are calculated. FCBM sets upper and lower limits for comfort temperatures (Mourshed 2006). If the internal zone temperature is either above or below the temperature limits for the prescribed comfort zone, then thermal environmental conditions are unacceptable to a majority of the occupants within that space. Factors that determine thermal environmental conditions are temperature, thermal radiation, humidity, air speed, and personal factors such as activity and clothing. Environmental factors are influenced by: 1) Radiant flow through transparent surfaces; 2) Internal (sensible and latent) heat gain from lights, people, and equipment; 3) Conductive heat flow through opaque (envelope) elements; 4) Radiant flow through opaque (envelope) elements; 5) Ventilation and infiltration heat flow through cracks and openings; 6) Inter-zonal heat flow between adjacent zones. Conductive and radiant flows through opaque elements are treated together under the “Fabric” category in Ecotect.

Following the Ecotect analysis, we modeled the same buildings using the Department of Energy’s (DOE) eQuest version 3.65 building simulation tool. eQuest analysis is supported by the DOE-2 simulation engine that uses a description of the building geometry, construction materials, schedule, environmental systems (lighting, HVAC, etc.), along with weather data, to perform an hourly simulation of the building. It has been validated by the Dept. of Energy (Neymark, Judkoff et al. 2002). eQuest is a user-friendly interactive Windows implementation of the DOE-2 program with added wizards and graphic displays to create a model and view simulation results. Because eQuest is prone to translation errors when porting a building model from another drawing program, we prepared the building geometry and assigned IECC envelope thermal properties and control schedules directly in eQuest using the Building wizard. Like Ecotect, locational and weather data was input according to each of the four climate zones selected for the study. eQuest produces summary as well as hourly report data based on contributions from walls, windows, people, plug loads, and

ventilation air. End use energy consumption for lighting, general space equipment, heating, cooling, ventilation, and pumps are tabulated (DOE-2 2009). Our results for both Ecotect and eQuest runs were compatible thus validating our preliminary results. The following sections provide detailed explanations and the results of our analysis. The numbers provided are drawn from the Ecotect simulation runs.

4.0 THERMAL ANALYSIS

The thermal analysis involves examining each of the four models (1:1, 1:2, 1:3, and 1:4) in each of the four climatic zones (cool, temperate, arid, and tropical). For each climate zone, four models are tested under equivalent interior thermal and schedule conditions. That is, the only differences among the four runs in the same climate zone are the building width to length ratio (aspect ratio) for one orientation at a time. In this study there are two main stages of the thermal analysis. The first stage is to find the sensitivity of the energy demand (heating and cooling loads) to the change of the surface area ratio (SAR), which relates to floor plan aspect ratio:

$$SAR = \frac{(floor\ perimeter \times floor\ height)}{floor\ plan\ area}$$

This analysis consists of thirty-two different simulation runs (matrix of four models and four climate zones), where cooling and heating loads are calculated for each model in two orientations (N-S and E-W). The results corresponding to N-S orientation are provided in Table 3, and the difference in the total energy use intensity between the two orientations is not significant, as shown in Figure 4.

Table 3: Energy demand verses SAR (N-S orientation)

Width to length ratio - increase in SAR												
Type Climate	1:1			1:2			1:3			1:4		
	Heating	Cooling	EUI	Heating	Cooling	EUI	Heating	Cooling	EUI	Heating	Cooling	EUI
	kwh/m ²			kwh/m ²			kwh/m ²			kwh/m ²		
Cool	49.8	9.4	59.2	51.9	9	60.9	53.6	8.7	62.3	55.9	8.4	64.3
Temperate	7.9	30.7	38.55	8.4	30.7	39.1	8.9	30.8	39.8	9.7	31	40.6
Arid	5.8	57	62.8	6.1	57.9	64.0	6.5	59	65.5	7	60.4	67.4
Tropical	0.0	62.5	62.5	0.0	62.75	62.75	0.0	63.4	63.4	0.0	64.1	64.1

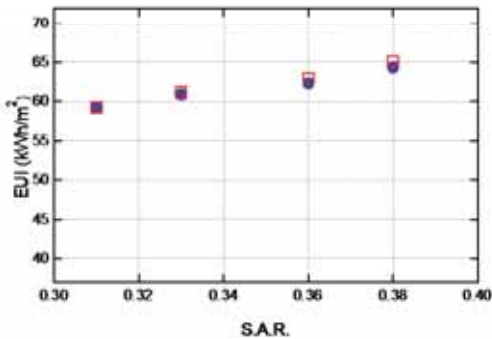

Figure 4A: Cool climate

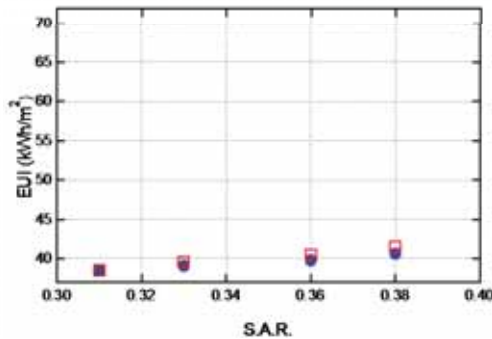

Figure 4B: Temperate climate

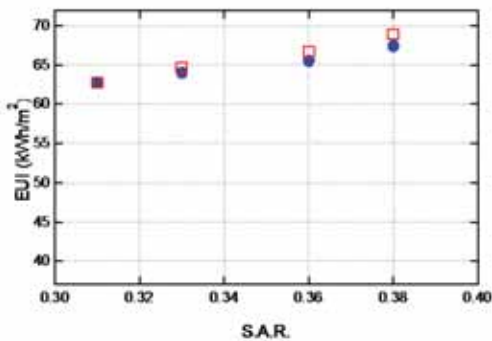

Figure 4C: Arid climate

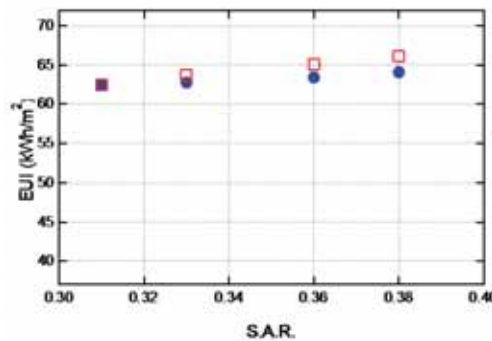

Figure 4D: Tropical climate

Figure 4: Sensitivity of EUI to the change in surface area ratio and orientation

Using the model of 1:4 aspect ratio as an example, the monthly and yearly energy demand ratios (EDR) are shown in Table 4.

$$EDR = \frac{\text{energy demand of East – West orientation}}{\text{energy demand of North – South orientation}}$$

Table 4: Energy demand ratio (model of 1:4 aspect ratio).

Months	Energy demand ratio (EDR)			
	Cool	Template	Arid	Tropical
Jan	1.01	1.01	1.03	0.96
Feb	1.01	1.02	0.97	0.99
Mar	1.01	0.99	0.99	1.05
Apr	0.99	1.02	1.04	1.07
May	0.97	1.04	1.05	1.06
Jun	0.99	1.04	1.03	1.05
Jul	1.011	1.034	1.026	1.055
Aug	1.02	1.02	1.02	1.05
Sep	1.00	0.99	1.01	1.03
Oct	1.01	0.98	0.99	1.01
Nov	1.02	1.00	0.99	0.99
Dec	1.02	1.02	1.03	0.97
yearly	1.01	1.02	1.02	1.03

In Figure 5, the passive solar heat gain ratio (PSHGR) of the 1:4 aspect ratio model is displayed.

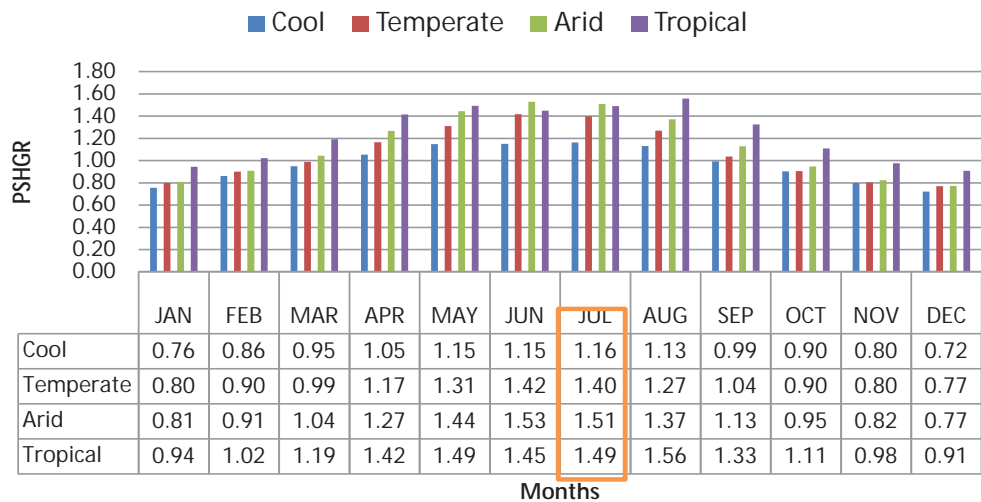

Figure 5: Monthly passive solar heat gain ratio.

In Table 5, the total heat gain and heat gain ratio (HGR) of the month of July are further tabulated by individual contributions of direct loads, internal loads, envelope and ventilation loads. We did this to analyze the impact of each of these heat sources, and also to determine how changes in building orientation affect passive solar heat.

Table 5: Breakdown heat gain (Wh) in July.

Climate	Cool					Temperate				
orientation	Θ=0		Θ=90		July HGR	Θ=0		Θ=90		July HGR
Direct	1.1E+08	17%	1.3E+08	20%	1.16	1.1E+08	8%	1.5E+08	11%	1.40
Internal	5.1E+08	78%	5.1E+08	75%	1.00	5.1E+08	40%	5.1E+08	38%	1.00
Fabric	2.1E+07	3%	2.3E+07	3%	1.11	2.8E+08	22%	2.9E+08	22%	1.02
Ventilation	1.3E+07	2%	1.3E+07	2%	1.00	3.8E+08	30%	3.8E+08	29%	1.00
Total	6.573E+08		6.783E+08		1.032	1.277E+09		1.325E+09		1.038
Climate	Arid					Tropical				
orientation	Θ=0		Θ=90		July HGR	Θ=0		Θ=90		July HGR
Direct	1.1E+08	5%	1.6E+08	8%	1.51	9.9E+07	10%	1.5E+08	14%	1.49
Internal	5.1E+08	25%	5.1E+08	24%	1.00	5.1E+08	50%	5.1E+08	47%	1.00
Fabric	6.1E+08	30%	6.2E+08	29%	1.01	2.2E+08	21%	2.3E+08	21%	1.05
Ventilation	8.3E+08	40%	8.3E+08	39%	1.00	2.0E+08	19%	2.0E+08	18%	1.00
Total	2.068E+09		2.129E+09		1.03	1.029E+09		1.087E+09		1.057

In this first stage of the thermal analysis, our purpose was to find out the sensitivity of energy demand to the variation of SAR. These results are presented in Table 3 where heating and cooling loads are provided for each aspect ratio corresponding with the four climate zones. In the Cool, Temperate, and Arid climate zones, the energy demand is increasing by an average percent increment of 1.7-2.7 % while the total is increasing 5.1-7.9% with respect to increase in SAR. This increasing energy demand may be considered slightly significant, where increasing the surface area by 20% leads to demand increased by 5.1-7.9% depending on the climate zone. However, in the tropical climate the energy demand is insensitive to variations of SAR, where the average increment percent is 0.4% and the total increase is 0.84%.

Figure 4 illustrates the differences in the energy demand which results from two building orientations (N-S & E-W) in each climate zone. The horizontal axis represents the SAR corresponding to the four building aspect ratios (1:1, 1:2, 1:3, and 1:4), while the vertical axis represents EUI. The differences in the EUI (demand/m²) are not significant, and the largest difference (of 3.1%) in energy demand for the opposing orientations occurs in the Tropical zone.

In Figure 5, we focused on the month of July, and find that direct heat gain (passive solar gain) resulting from a building oriented E-W is much higher than in the case of a building oriented N-S. This in itself might be not unexpected, yet upon closer examination, we note that the demand in this month and overall yearly cooling loads are nearly identical for both orientations as shown in Table 4. In order to know why, the heat gain broken down to its respective components and presented in Table 5. A significant difference in July's heat gain ratio (July HGR) is due to direct heat gain, which naturally varies depending on the climate zone. However, because the amount of heat gain through this source represents only 5- 20% of the total heat gain, consistent for both orientations, the effect of direct solar radiation does not significantly impact total heat gain. The total heat gains shown in Table 5 for the month of July, are slightly higher than the corresponding demand as shown Table 4. The reason is because even with some heat gain, the interior temperature is still within the comfort range and there is no need for cooling.

4.1. Demand sensitivity -- glazing walls built to code

The second stage of the thermal analysis is to find out why there are small differences in the energy demand, even though the buildings were faced to maximum passive solar heat gain in case of E-W orientation. This indicates that the reason maybe because the usage of high quality envelope. For this analysis, we modeled the glazing walls with regular glazing, which has less optimal thermal properties ($U=6.0 \text{ W/m}^2\cdot\text{K}$ & $\text{SHGC}=0.94$). The analysis is performed to evaluate energy demand for both orientations. Accordingly, the results showed that buildings oriented E-W demand 12% more energy whether it oriented N-S, and also the passive solar heat gain in July is significantly increased.

In other words, we investigate the difference between built to energy code envelopes and regular glazed envelopes on passive solar heat gain. The outcomes demonstrated that due to code requirements, direct heat gain is reduced by 20-30% in the N-S and E-W orientations (Table 6 for arid climate). This also helps to explain why there is that small effect result from the variation of building orientation on monthly and yearly energy demand.

Table 6: Breakdown heat gain (Wh) in July in Arid climate – regular glass envelope.

	Heat gain (Wh)				July HGR
	$\Theta=0$		$\Theta=90$		
Direct	7.4E+08	24%	1.2E+09	34%	1.62
Internal	5.1E+08	16%	5.1E+08	14%	1.00
Fabric	1.0E+09	33%	1.0E+09	29%	1.01
Ventilation	8.3E+08	27%	8.3E+08	23%	1.00
Total	3.099E+09		3.564E+09		1.15

CONCLUSION

This paper examined four different buildings' footprint aspect ratios and two orientations in order to investigate the sensitivity of site layout planning characteristics on the energy consumption of high-rise office buildings in four different climate regions. By simulating each building configuration, we were able to draw two major conclusions regarding building energy consumption.

(1) For the buildings in Cool, Arid, and Temperate climates, the energy demand may be considered slightly sensitive to changes in SAR. Our models suggest that increasing the surface area of the building envelope by 20% leads to increased energy demand by 5.1-7.9% depending on the climate zone. On the other hand, the energy demand of buildings in a Tropical climate zone appear to be insensitive to variations in SAR. For the three other climate zones, it is important to note that an increase in the surface area may lead to an increase in the materials used, may lead to an increase in the cost and embodied energy. Also, increases in the surface area may results in an increase in the area exposed to wind pressure, which might lead to the need of a larger size of structural element, which impacts the cost and embodied energy of these buildings.

(2) Our models demonstrate that the energy performance of high-rise office buildings is not sensitive to passive solar gain as evidenced by changes in orientation insofar as the buildings' envelopes are built to code. We found the greatest difference in energy demand (by 3.1%) for buildings in a Tropical climate zone. This small to negligible difference in EUI for opposing orientations can be explained by the fact that commercial buildings are typically internally load dominated, and as such, site layout planning is not as important as ensuring efficient and load reducing internal operations. For office buildings whose envelopes are not built to IECC energy standards, however, passive design strategies such as solar heating and natural cooling may have promise (Lam and Li 1999).

High quality insulated envelope provides greater flexibility to manipulate with the building site plan (geometry) without resulting in significant changes in energy demand. On the other hand, this constrains a designer's ability to take advantage of passive design strategies. Because IECC code buildings are not particularly sensitive to solar gain, this leaves little room for solar strategies to play a role in reducing energy demand.

ACKNOWLEDGEMENTS

The authors wish to acknowledge The Libyan Ministry of Education for providing financial support for this project.

REFERENCES

- Al-Homoud, M. S. 1997. "Optimum thermal design of office buildings." *International Journal of Energy Research* 21(10): 941-957.
- Brager, G. S., E. Ring, et al. 2000. "Mixed-mode ventilation: HVAC meets Mother Nature." *Engineered Systems*.
- Crawley, D., S. Pless, et al. 2009. "Getting to net zero." *ASHRAE Journal* 51(9): 18-25.
- DOE-2, 2009. eQuest. J. J. H. A. (JJH).
- DOE. 2012. "Buildings Energy Data Book." *Buildings Sector Energy Consumption* Retrieved November 2014, from <http://buildingsdatabook.eren.doe.gov>.
- EIA. 2008. "Major Fuel Consumption By End Use of all Buildings." *Commercial Buildings Energy Consumption Survey: Energy End-Use Consumption Tables*, November 2014.
- EPA/OAP, U. 2009. *Inventory of US Greenhouse Gas Emissions and Sinks: 1990-2007*. Washington, US Environmental Protection Agency Office of Atmospheric Programs.
- Harvey, D. L. D. 2009. "Reducing energy use in the buildings sector: measures, costs, and examples." *Energy Efficiency* 2(2): 139-163.
- Hoque, S. 2010. "Zero Energy Homes in New England." *Journal of Green Building* 5(2): 79-90.
- IECC 2009. 2009 International Energy Conservation Code. Country Club Hills, Illinois, International Code Council, Inc.
- Lam, J. C. and D. H. W. Li 1999. "An analysis of daylighting and solar heat for cooling-dominated office buildings." *Solar Energy* 65(4): 251-262.
- Li, D. H. W. and J. C. Lam 2001. "Evaluation of lighting performance in office buildings with daylighting controls." *Energy and Buildings* 33(8): 793-803.
- Meyer, U. 2013. *Reaching New Heights: The world's first Passive House office tower rises over the Danube*. GreenSource: A Magazine of Sustainable Design. http://greensource.construction.com/green_building_projects/2013/1309-rhw2-office-tower.asp, McGraw Hill Construction.

Representing complexity: Understanding performance in integrated design

Clifton Fordham¹

¹Temple University, Philadelphia, PA

ABSTRACT: A discourse of sustainability in architecture promises to be an immutable fixture of research, a shift that can be attributed to climate change and natural resource depletion. Sustainable buildings can be achieved through numerous avenues including material selection, HVAC and lighting system selections, and enclosure detailing. The effectiveness of these strategies depends on an understating of climate, site, building activities, form implications, construction methods, regulatory and social context.

The term “integrated design” best describes the synthesis of multiple design factors so that they resulting solution is meshed as opposed to layered. Central to the practice of integrated design is a necessity for knowledge, particularly technical knowledge grounded in science; knowledge that has to coexist with other types of design knowledge. This shift challenges limits of current architectural theory and pedagogy. It also represents a move toward increased complexity in design, especially at the beginning of the design process when decisions offer the best probability of high performance buildings.

The notion of complexity challenges current limits of design thinking. In his essay *Embracing Complexity in Building Design* Leonard Bachman compares complexity in building design to dynamic systems thinking as opposed to an understanding of buildings as static objects. The apparent static nature of buildings encourages a reductionist understanding of buildings typified by photographic images, and renderings. Since complexity in high performance buildings is not only evident in the material of building, how can it be better understood by stakeholders in the design process, as well as non-participants, seeking a better understand of building performance?

Legibility challenges exist since a complex design does not necessarily appear complex. If complexity to woven into buildings, historical means of representing and evaluating buildings become inadequate. Diagrams have become a part of academic analysis in high performance buildings since they are particularly helpful in illustrating abstract principals and non-geometric activity in buildings including movement and relationships. However, there are limits to the effectiveness of diagrams, particularly those that use arrows to represent air flow and heat transfer.

Data in design research has been relatively scarce despite the fact that buildings are material objects that lend themselves to quantification. When data is used, is usually limited to areas counts, and metrics are buried in performance benchmarks such as energy and load criteria. Research on building performance by architects must incorporate increased use of data if it to illuminate the complex factors that underpin high performance buildings including energy flows, space effectiveness, efficiencies, materiality, and user satisfaction. This paper provides cases on how data can be utilized alongside traditional graphics to better understand integrated design

KEYWORDS: Integrated Design, Complexity, Knowledge, Data, Representation.

INTRODUCTION

Designers of buildings are required to address a multiplicity of program and regulatory requirements. The additional objective of achieving high-performance building results in additional complexity since it is necessary to understand complex natural systems in which buildings are situated as well as suitable building technologies. (Moe 2008, 6-7) In close relation to need for suitable knowledge is the availability of tools to process information and assist in the evaluation of design proposals. Currently most of the tools for evaluating energy performance and other performance factors are utilized late in the design process, or after a building has been constructed. As a result, architects rely heavily on experience based intuition early in the design process. (Lawson & Dorst 2009, 84, 96-100)

This paper addresses two primary challenges to integrated design, understanding how buildings perform, and the problem of measuring performance of buildings early in the design process. Understanding is closely related to our ability to recognize information and situations. This paper focuses on the designer's ability to see, and make more sense out of what is perceived. More specifically, it focuses on tools available to measure building performance which are tied to quantitative factors as well as methods under-development for measuring qualitative components of the built environment. Hurdles to developing

measurement systems include the prototypical nature of buildings which makes comparison difficult. This study utilizes an evaluative analysis to explore different measurement tools, and explain how these tools relate to questions of building performance. (Walliman 2011,11-12)

1.0 DIFFERENCES OF PERSCRIPTIVE AND PERFORMANCE OBJECTIVES

Building outcomes are difficult to measure because designs are shaped by forces emanating from different locations, including goals that are not comprehended at the time of project initiation. They are also difficult to measure because the source of measurements for prescriptive and performance objectives can be applied to the same project. Owner goals for a project are typically codified in a project brief supplemented by input during the design process. Because forces impact the design process deriving from outside the owner's demands, it is difficult to measure project success against owner established goals whether prescriptive or performance based. These external forces include regulations, design team input, and builder input. Rule based conventions are easier to implement than performance criteria. (Lawson 2009, 68)

Examples of rule base conventions that shape buildings include building codes, for which compliance is relatively easy to measure. Similarly, rating systems such as LEED are prescriptive in nature as opposed to performance based, and offer a baseline for clearly identifying success or failure within the system. However, closed rule based systems such as LEED do not adequately address performance objectives that do not fit within the rules established by the system. Rule based systems often miss alternate paths to high-performance buildings available earlier in the design process limiting the overall performance potential of buildings. An example would be the opportunity to shape building form to respond to local daylighting conditions prior to designing an optimal HVAC system. (Schwitter 2005, 113)

Although design objectives need to be identified early in the design process, if goals are too prescriptive or detailed, they prevent architects from identifying additional problems to solve; something that is pivotal to the ability of designers to make meaningful contributions to specific projects. This is because architects make intuitive creative leaps by producing solutions before all of the facts of a design have been solved for. Inherent in this process is the application of knowledge to identify problems beyond those specifically identified in the brief. By making creative leaps, the architect can understand and evaluate proposals by critiquing proposals, and generate more appropriate solutions. This results in an iterative process where more knowledge gained about the problem. When performance based criteria allows for more architectural thinking, complexity can be better integrated into building design. (Lawson 2009, 34-42)

Integrated design emerges from a process that recognizes that high-performance buildings are not autonomous objects, but rather perform in a manner that encompasses ecological, sociological, psychological, economic, political, climatic and technological and natural systems. (Kolarevic 2005, 195) By necessity, high-performance buildings account for time after commissioning. It also raises the need for designers to have more knowledge on how individuals use facilities, how they are serviced, and maintained. This necessitates better communication between designers and owners about how a facility will be used, as well as common ground for understanding and measuring building performance. Clearer communication and measurement tools are needed to assist designers and owners in locating a common understanding of how designs match owner expectations. It also calls into question the notion that architecture falls outside the boundaries of quantification and measurement, an argument that has been supported by many architects and architectural critics. (Augenbroe 2005, 99)

There are legitimate reasons why many architects disagree with the notion that building performance should be measured and quantified. Operational aspects of buildings have traditionally been associated with accommodation of specific activities, structural and mechanical systems. Rational understanding of building in this light is reductionist in nature, and has led to uninspired and banal buildings, omitting benefits of architecture independent of function. Architecture of the post-war years provides a plethora of examples of impoverished buildings that represent the sum of functional components, and neglect the representative side of architecture. This perspective illuminates the dichotomy between art and function, and the murky area where they overlap. It also presumes that buildings are not machines like automobiles, which are designed for limited applications. (Leatherbarrow 2005, 8-9)

2.0 SOURCES OF BUILDING INFORMATION

It is no surprise that attempts to measure building performance emanating from outside of the architectural profession have been the most successful. The most common source for building information comes from the construction of the buildings. Data derived from cost indexes can be used to anticipate and compare the initial costs of components, assemblies, and entire structures. While aggregate data collected by organizations such as RSMeans, do not reveal specifics of survey samples, cost data can be useful in establishing project cost discipline, prior and during construction. This data does not speak to the myriad buildings objectives; and loosely addresses building quality. Architects are correct to be wary of the weight given to this information because of large quality deviations in buildings. Cost is only one means of measuring buildings, and must be combined with other factors to gain a true idea of building value. (Ashworth & Hogg, 1-9)

Individual components and products within buildings can be measured more easily than composite structures. They are subject to universal testing, and contain data that contributes to greater understanding of design and built structures. Quantifying building materials has benefits other than supporting cost estimating prior to construction, namely measuring the environmental impact of materials prior to installation, including embodied energy of materials. Utilizing BIM software and updating design documents to reflect construction changes, and builder design input, is not perfect reflection of future as-built conditions, but accurate enough to derive and understanding of the material reality of buildings. BIM Software has been developed by Autodesk and its partners to link databases of information on the embodied energy of building materials and products.¹

Anticipating and evaluating systems performance is easier if a product is lab tested as opposed to assembled on-site. Systems such as conveyance systems can be tested after installation against manufacturer's product data based on laboratory testing. Similarly curtain wall and lighting can be modeled, commissioned, and tested after installation against performance criteria available from codes, or factory testing scenarios. However, some systems such as lighting react more dynamically when situated within actual site conditions, many of which are not anticipated at the point of design and specification. This can lead to design solutions that underperform because decisions are based on typical industry assumptions instead of specific site conditions that can be anticipated through better communication and modeling.

3.0 OVERCOMING HURDLES FOR MEASURING BUILDING PERFORMANCE

In their book *The Integrative Design Guide to Green* the 7group and Bill Reed provide an example of lighting designers using design standards provided by industry trade organizations such as ASHRE, instead of utilizing information available that would change their design assumptions. By utilizing high reflective paint, they discover that lighting levels could be reduced by 25% in a new school building. The architect on the project was unaware that such an option was available and that if the right paint color was selected the mechanical engineers could reduce the size and capacity of the HVAC system saving money and resulting in a more energy efficient building. By not sharing data such as paint specifications early in the design process, decisions are made that diminish building performance for decades in the future. The authors found that some vital communication between consultants early in the design process, almost never happens. (7group and Reed 2009, 19-22)

Some engineers are moving past utilizing prescriptive criteria, to work with architects to develop solution better suited to specific problems where solutions evolve during the design process. Practices such as Bruno Hapold have utilized advanced software programs including TENSYL to analyze cable structures which emerge from performance-based designs. The same program has been adapted to assist with the design of amorphous shapes, including long-span structures out of non-typical materials such as cardboard. CFD (computational fluid dynamics) modeling (fig. 1) has been applied by some mechanical engineers to model air flow in non-conventional design proposals, and to support advanced technological design proposals. CFD has also been used to modeling light pollution on a complex urban site. Similarly, CAM tools are being used to model and test prototypical building components early in the design process. (Schwitter 2005, 115-117, 119-12)



Figure 1: CFD Model of Performing Arts Center. Source: *Performative Architecture: Beyond Instrumentality*.

Parametric modeling is being used to correlate area requirements with structure so that form and structural components can be adjusted to respond to subtleties in program and site. An example is the TGV train station in Avignon, France that balances where software was used to adjust a repeating section to respond to nuances in anticipated program use and site conditions. Variety was instilled in the enclosure material treatment, and the changes in cladding shape derived from their specific location on the building, resulting in shifting glass treatment across the entire building surface. Thermal criteria for the project derived, not from standard codes, but from the anticipated use of the structure. RFR an engineering practice in France found similar benefits in early project modeling with the railway extension in Strasbourg, France, where structure, glass, enclosure, and HVAC considerations were meshed with formal objectives. (Blassel 2005, 126, 131-132)

4.0 MEASURING SPACE AND FUNCTION

Numerous factors make it difficult to measure the performance of building spaces, and their relationship to each other; particularly before a building is commissioned. Among the factors are the social and psychological nature of architecture space; as well as the variety of space configurations brought about by uniqueness of location and program nuance. Additionally, the formal nature of architecture creates challenges to measurements as a means to valuing aesthetics and space; something theorist David Leatherbarrow notes, is difficult to when future contingencies about how space will be used and interpreted is almost impossible to predict. To avoid bland and overly efficient buildings such as many building constructed after World-War II, he advocates that contingency be factored into buildings to allow for a loose fit between program and design. (Leatherbarrow 2005, 8-9)

When program requirements are stringent, as in the case of health care facility design, case study databases have been created to assist in the evaluation of designs, an approach known as EBD (evidence based design). EBD utilized information gained from designers, and surveys of occupants regarding how they perceive buildings to serve their needs. Data gleaned from post-evaluation studies (fig. 2) can be used to make cases during the design process as an alternative to relying of testimony from experience. The user centric nature of this evidence runs counter to current ideas of expert evaluation and control of design. Another challenge of EBD is that for it to work effectively, information derived from design, construction, and surveys, must be widely accessible; something that is contrary to the way that building participants handle information about projects. (Hamilton & Watkins, 2009, 22-23)

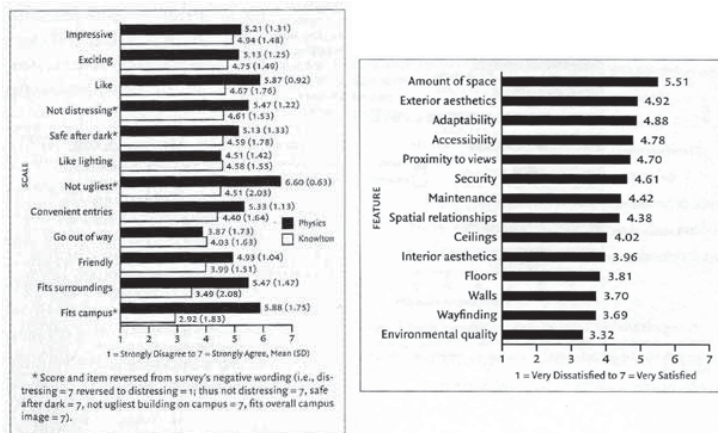

Figure 2: EBD study tables. Source: *Designing For Designers, Lessons Learned From Schools of Architecture.*

Efforts to develop databases of precedent in architecture parallel processes that have been implemented across the board in medicine and law as a means for providing common sources for learning and evaluation. In the case of law, precedence plays a key role in the advancement of working standards that includes knowledge from outside of law such as from economics and sociology. The legal system is not a closed system, but rather an organic system that evolves in reaction to external influences which are then codified in new law. Similarly, the medical profession relies on knowledge gained from scientific studies that are recorded and disseminated to practitioners as a common basis for practice. (Bachman 2012, 55)

Systems have emanated from outside the architecture community that can measure performance of individual building systems against quantitative benchmarks, building codes, or manufacturer's data. A

building performance rating systems called *Standards for Whole Building Functionality and Serviceability* has been developed by ASTM (American Society for Testing and Materials). The system has partitioned building performance factors into thirty-two categories including floor measurements, energy management, air quality, and disaster risk. Hypothesized methods of evaluating building performance have been developed such as the *General AEC Reference Model* utilizing performance indicators (PI's) where building functions and systems are divided into manageable chunks. The system has yet to be adopted in practice, with advanced variations of this PI system currently under development. (Augenbroe 2005, 99-104)

5.0 COMPLEXITY AND PERFORMANCE

There are architects who are using computer algorithms to generate forms with program algorithms derived from program databases. Examples include Nox Architects who test out new forms of utilizing software to study new ways of organizing program areas based on data including usage rates to bring down the size of an office that would normally allocate space without considering activity intensities. The result was a building approximately thirty percent smaller. The process utilized by Nox is significant because it incorporates information deriving from specifics on the project, and not from outside the project, resulting in a complex appearing form. (Spuybroek 2005, 164-166)

More often attempts by architects to introduce the notion of complexity into buildings have confused the aesthetics of complexity, which often result from complex appearing computer generated forms, with performance-based complexity. Actual complexity in buildings can exist within simple forms and understated articulation. Complementary elements produce results that are greater than the sum of parts, an important characteristic of complexity. Integrated or meshed complexity operates below, or within, visible surfaces challenging observers to comprehend complexity and necessitating techniques for recognizing complexity beyond form. This is important because the benefits of high-performance buildings derive from their complexity. (Kolarevic 2005, 195)

The amount of knowledge and expertise necessary to design buildings generally lie beyond the capabilities of a single organization. With high-performance buildings this is more acute as there is greater scope of performance considerations, and a larger set of questions to respond to. Part of the role of architects is to identify and assemble experts who work with the architect and owner to develop a building that incorporates the collective contribution of talents. Architects must be able to recognize, identify, and understand broad issues inherent in the design problem and evaluate feedback. Despite high levels of knowledge which are required, skilled architects can filter knowledge that would prevent them from moving beyond pragmatic questions. (Lawson & Dorst 2009, 38, 126-132)

6.0 ADDRESSING TRADITIONAL PROJECT DELIVERY CHALLENGES

One of the keys to designing and constructing higher performing buildings is making decisions earlier in the design process that factor in criteria that are difficult to address later. In the traditional project delivery process, broad decisions including site placement, form, and program organization, and are made early in the process by the architect. Consulting engineers, particularly mechanical engineers, provide their greatest contribution after the schematic stage, adapting mechanical systems to the initial design. This leaves little opportunity for the mechanical engineers expertise to influence design decisions already made earlier in the process. Construction knowledge brought by builders related to constructability and cost also enters the process late in the traditional project delivery process, often leading to decisions that compromise building performance under the guise of value-engineering.

Attempts to rectify these liabilities have included bringing builders into the design process earlier, in some part prompted by a lack of confidence in architects. Often costs become the paramount topic in these relationships, as the builder take the role of providing downward cost pressure, crowding out a view of longer-term operating costs and value. This is problematic considering that it is estimated that construction costs represent a small fraction of overall ownership costs over the lifetime of a facility; estimates that are understated since they do not address productivity losses due to cost reductions made during the design process. Part of the challenge for designers to preventing decisions being made that lead to under-performance over time is including key issues in initial design and programming exercise, including strategies for making cost reductions.

Currently there isn't a common method of categorizing design objectives, against which results can be measured. As a result it is difficult to compare projects and projects across time and space. The possible beginning of universal system can be found in the post-occupancy study of Wolfgang Preiser and Jack Nasar who identified the follows categories of evaluation: health safety, security, functionality, workflow, efficiency, social performance, psychological performance, and cultural performance. Notable from their list

is adaptability of structure for future uses, embodied energy, operating energy use, assembly durability, and space-efficiency; performance factors that have a better track record being measured objectively. (Naser, Prieser & Fisher 2007, 63-64)

7.0 REPRESENTATION WITH TRADITIONAL DESIGN DOCUMENTS

Because effective integrated requires greater input and cooperation across participant specialties, communicating information effectively becomes imperative. Some of the hurdles to more effective communication can be found in the way drawings have been produced, and the objectives addressed by different media. The primary means of representing design information had been two-dimensional plans, elevations, and sections; supplemented with perspective images and/or a physical models early in the design process. Information embedded in design proposals is dispersed throughout drawings and specifications.

As drawings accommodate technical information, including notes and hatches; they lose become more difficult to read by lay individuals. It is also necessary to construct a mental picture of the design because portions of the design are located on different drawing sheets and in narrative specifications. Often very few project participants ever construct a complete picture.² Computer models allow for the continual development of three-dimensional images throughout the design process, but presentation quality images are rarely are produced after schematic design, although mock-ups are produced late in the design process, or during construction. Alternatives to traditional line drawings and three-dimensional representations include diagrams which are especially usefully in conveying concept ideas including form progressions, program and site relationship diagrams, structure, and program area diagrams.

Diagrams are helpful for distilling fundamental concepts and can be scaled and graduated to represent hierarchy. Structure, circulation, massing, and zoning strategies are examples of characteristics that are conveyed. More often than not diagrams have are used to communicate fundamental design decisions after they have been solidified in a proposal. Available data includes building volume, relationship statistics such as volume to user population, estimated seasonal BTU use, embodied energy, estimated replacement times and costs, opportunity costs, and functional efficacy metrics. Data is critical to the functioning of most disciplines, including those rooted in the social-sciences. Statistics are used to identify patterns, and pose solutions in professions such as law and medicine. Although information is packed into buildings, architects are reluctant to utilize data to better understand and communicate value of their services. (Bachman 2002, 9-10)

8.0 CHALLENGES TO VISUALIZING INFORMATION

There are limited visualization techniques available for illustrating sustainability performance of designs. Much of this has to do with the static nature of buildings, versus the dynamic reality of light movement, energy flows, and interactions of buildings within ecological systems. A common answer is to use diagram section drawings to illustrate air flows through naturally ventilated buildings has led to the use of diagramed sections (fig. 3). Another is to use light studies depicting scenarios at different times of the year. More often dynamic activity is conveyed verbally with standard drawings. Some of this can be explained by the tradition of presenting buildings as static objects independent to larger systems that interact with them. Systems based relationships rely in objective principles, and can be quantified, something seen as subservient to larger architecture goals.³

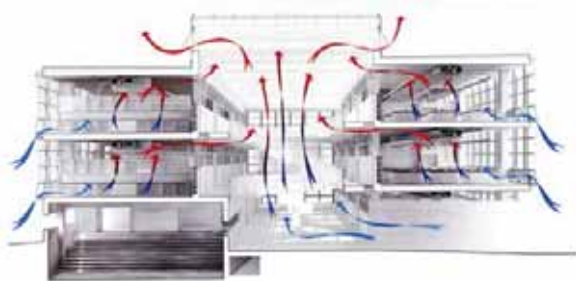

Figure 3: Section with Air Flow. Source: *Integrated Design in Contemporary Architecture*.

9.0 COMPUTER SIMULATIONS

Another challenge is the fragmented nature of design computation tools. Some of this is due to use of programs including Rhino and Sketch-up early in the design process, as opposed to BIM. Computational tools offer great potential to aid in the generation and analysis of designs, particularly early in the design process where intuitive hypothesis can benefit for immediate feedback and adjustment. This belies the tendency for most performance based computation tools to be use later in the design process to verify solutions that already have significant amounts of detail and are difficult to change. (Schwitter 2005, 115) Programs have been developed that are based on graphic engines that are suited for building design. Chief among these are programs that work Autodesk including REM and Ecotect, Greenbuid, Talley, and CFM modeling that build on BIM platforms. Chief disadvantages to using BIM models for analysis is the amount of detailed information that BIM models general hold, and the fact that early level schematic design is difficult with BIM relative to other modeling programs such as Sketch-up and Rhino which were not developed for building professionals. Another liability of analysis tools has been the specialized nature of programs necessitating working across different platforms. (Yi 2012, 164)

Sefaira which is plug-in and web-based program compatible with Sketch-up and Revit address some of the liabilities of other energy analysis software. Aimed a use in the beginning of the design process, when decisions have the largest opportunity to be integrated with site conditions, the program permits real-time feedback of design changes. Its user friendly interface also allows for easy comparison of design options by filtering key measures such as building area and volume, glazing areas and type, shading types, insulation factors, and BTU use over time of day. Sefaira is designed for architects and does not include advanced mechanical and ventilation analysis tools. Like most visualization tools, there is not yet capability to integrate quantitative information derived from systems performance with cost information, durability statistics, and qualitative functions derived from post-occupancy evaluations. Adaptable interfaces that are streamlined like the Sefaira's allow for progressions in design to be understood, conveyed, and measured by experts and lay individuals who are stakeholders in project decisions.

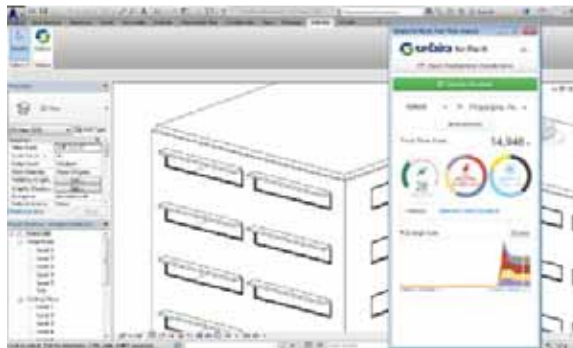

Figure 4: Interface from Sefaira Modeling Program. Source: www.sefairia.com

CONCLUSION

Increasing performance objectives necessitate development of better tools for understanding building properties early in the design process, through construction and commissioning, to operation. Right now most of the tools are effective later in the design process when it is too late to implement many design strategies. This study addresses some of the factors that have retarded development of better tools and measures of building performance. It also identifies examples of where data is used to shape evaluate building projects. Because availability of this data is limited, the building industry misses common grounds for problem solving. Also, because architects have been slower than other building professionals to use data as a means of evaluating building performance, there is reason to consider what the ramifications will be if they do not develop more objective methods for assessing performance.

REFERENCES

- Ashworth, Allen and Hogg, Keith. 2000. *Added Value in Design and Construction*, Pearsons Education, Edinburgh Gate, England.
- Augenbroe, Godfried. 2005. "A Framework for Rational Building Performance Dialogues" in *Performative Architecture: Beyond Instrumentality*, Spoon Press, New York.
- Bachman Leonard. 2012. *Two Spheres: Physical and Strategic Strategies in Architecture*, Routledge, Abingdon, England.

- Blassel, Jean-Francois. 2005. "Engineering in a Performative Environment", in *Performative Architecture: Beyond Instrumentality*, Spoon Press, New York.
- Hamilton, Kirk and Watkins, David 200., *Evidence Based Design for Multiple Building Types*, Wiley, Hoboken.
- Kolarevic, Branco. 2005. "Computing the Performative", in *Performative Architecture: Beyond Instrumentality*, Spoon Press, New York, NY.
- Lawson, Brian and Dorst, Kees. 2009. *Design Expertise*, Architectural Press, Oxford, England.
- Leatherbarrow, David. 2005. "Architecture's Unscripted Performance", in *Performative Architecture: Beyond Instrumentality*, Spoon Press, New York.
- Moe, Kiel. 2008. *Integrated Design in Contemporary Architecture*, Princeton Architectural Press, New York.
- Naser, Jack, Prieser, Wolfgang & Fisher, Thomas. 2007. *Designing For Designers, Lessons Learned From Schools of Architecture*, Fairchild Books, New York.
- Schwitzer, Craig. 2005. "Engineering Complexity: Performance Based Design in Use", in *Performative Architecture: Beyond Instrumentality*, Spoon Press, New York.
- Spuybroek, Lars. 2005. "The Structure of Vagueness", in *Performative Architecture: Beyond Instrumentality*, Spoon Press, New York.
- Walliman, Nicholas. 2011. *Research Methods: The Basics*, Routledge, New York.
- Yi, Yun Kyu. 2012. "Building Performance and Computational Simulation", in *Design and Construction of High-Performance Homes: Building Envelopes, Renewable Energies and Integrated Practice*, Routledge Abingdon, England.

ENDNOTES

¹ KieranTimberlake partnered with Autodesk and PE International to develop a software program called *Tally* which is used with Revit to provide life cycle assessments.

² General contractors rely significantly on subcontractors from specific trades to decode documents.

³ The larger part of Leonard Bachman's Leonard book, *Two Spheres: Physical and Strategic Strategies in Architecture* address the chasm between what he identifies as physical design and strategic design.

The potential of predictive modeling and automated building facade elements to attain thermal comfort

Troy Peters¹

¹Wentworth Institute of Technology, Boston, Massachusetts

¹University of Massachusetts, Amherst, Massachusetts

ABSTRACT: Buildings are the largest contributor to climate change. Energy use and the release of carbon green house gasses by buildings are driving climate change while at the same time weather extremes are driving more energy use in buildings. Designing buildings that use less energy and possibly no energy for heating and cooling can break this feedback loop.

Passive solar design utilizing energy directly from climate and weather patterns and high mass for heating and cooling has been studied extensively. However, the problems with passive solar heating and night ventilation of mass is that human thermal comfort is not always achieved due to over heating in both heating and cooling modes, large indoor diurnal temperature swings, and the unpredictable nature of the weather from day to day and year to year. Climate change will only exacerbate the problem because the climate that a passive building was designed for might change and the anticipated weather extremes may fluctuate in ways the designer could not expect.

Predictive modeling is a method used to predict future performance and foresee the significances of change. It can be used in a building to modify the present characteristics of the building to increase the future performance of thermal comfort. The characteristics in a passive solar building that can most easily be changed are the use of operable night insulation on windows, ventilation rate and solar gain by use of operable shading. Weather forecasting and solar radiation forecasting has been modeled but is it accurate enough for building simulation modeling?

This paper explores the potential of using predictive modeling and the automation of facade elements to achieve thermal comfort in buildings, and in particular the use of weather forecasts to help a passive solar building use the usual high thermal lag time to its advantage. These are investigated through a review of the literature on predictive modeling and an energy simulation on a simple single zone room that is heated by direct gain passive solar. The simulation results show that predictive modeling has potential to keep a passive solar building in the thermal comfort zone on consecutive days of low solar radiation.

KEYWORDS: Predictive Modeling, Thermal Comfort, Passive Survivability, Passive Solar Building

1.0 INTRODUCTION AND BACKGROUND

Climate change along with corresponding weather extremes are creating new and pressing problems for the built environment. Buildings are the largest contributor to climate change using 39 percent of U.S. primary energy consumption (21 percent residential and 18 percent commercial in 2006). Heating and cooling of buildings accounted for 39 percent of residential total energy end use and commercial buildings 32 percent. It can be calculated that heating and cooling of buildings accounted for 14 percent of the total U.S. primary energy consumption. Energy use and the release of carbon green house gasses by buildings are driving climate change while at the same time weather extremes are driving more energy use in buildings. Designing buildings that use less energy and possibly no energy for heating and cooling can break this feedback loop. Net zero energy buildings that produce the same amount of energy as they use, still have a net gain in released green house gasses as they can supply and draw energy from the grid that may use energy produced by fossil fuels.

1.1. Passive solar design

Passive solar design utilizing energy directly from climate and weather patterns and high mass for heating and cooling has been studied extensively peaking in the late 1970's. Heating and cooling energy use in passive buildings has been reduced by the manipulating of: window orientation, size, type and the use of operable night insulation; insulation level of walls, roof and floor; mass type, area and thickness or the use of phase change materials; ventilation rate, natural, mechanical and heat recovery; and horizontal and vertical shading device both fixed and operable.

The problems with passive solar heating and night ventilation of mass is human thermal comfort is not always achieved due to over heating in both heating and cooling modes, large indoor diurnal temperature swings, and the unpredictable nature of the weather from day to day and year to year. Climate change will only exacerbate the problem because the climate that a passive building was designed, might change and the anticipated weather extremes may fluctuate in ways the designer could not expect.

Over heating and temperature swings are minimized in passive solar buildings by the use of thermal mass whose characteristics, material, exposed area and thickness, are tied as a ratio to the characteristics of the equator facing window, area and type. As a rule, the larger the area of equator facing glazing, the greater the area of thermal mass. Large window areas lead to large areas of mass, usually a ratio between three and nine mass area to window area. Thermal mass will temper and phase-shift the effects of solar radiation, indoor and outdoor temperature and ventilation in a building. The time-shifting effect of thermal mass may also contribute to thermal discomfort if the mass is too warm when cooling is desired or too cold when heating is desired.

1.2. Predictive modeling

Predictive modeling is a method used to predict future performance and foresee the significances of change. It can be used in a building to modify the present characteristics of the building to increase the future performance of thermal comfort. The characteristics in a passive solar building that can most easily be changed are the use of operable night insulation on windows, ventilation rate and solar gain by use of operable shading.

Some of the questions that this paper addresses are:

- Can predictive control improve the energy performance and thermal comfort in a passively heated and cooled building using only façade elements?
- Which building elements are the most effective in providing thermal comfort in a predictive control system?
- Is weather forecasting and solar radiation forecasting accurate enough for building simulation modeling?

These questions are investigated through a review of the literature on predictive modeling and an energy simulation on a simple single zone building that is heated by direct gain passive solar. The simulation first optimizes the zone through iterative parametric changes. The simulation then looks at keeping the operative temperature of the zone in the PMV comfort range for a two-day period of low direct solar radiation using predictive modeling.

1.3. Literature Review of Predictive Modeling

Predictive control and predictive modeling studies have mostly been done on buildings that rely on mechanical heating and cooling systems but the studies contain lessons for passive system design. The studies have used stimulation, test rooms and real buildings. Predictive control showed good results in the high mass building with radiant heating in a full scale outdoor test room. The floor heating system control by generalized predictive model was then evaluated through computer simulations (Chen 2002).

Model predictive control generally provides superior performance to conventional HVAC controllers. The accuracy of the model and weather forecasting affect the performance of MPC. Weather forecasts should be updated frequently to improve controller performance. Simple MPC systems outperformed the conventional control systems that do not use any predictive algorithms. Thermal storage can be used for peak shifting and MPC with thermal storage will outperform systems without thermal storage. Buildings with little thermal mass can use water storage to improve the performance of the building. (Afram, 2014)

Another study looked at the control of the heavyweight radiant slab system in a typical office building during the summer season in a dry and hot climate. (Feng, 2015) The chiller was eliminated and the only cooling source is a cooling tower. The MPC controller was able to maintain zone operative temperatures at the thermal comfort level more than 95 percent of the occupied hours for all zones. Compared to a typical HVAC controller, MPC reduced the cooling tower energy consumption by 55 percent and pumping power consumption by 25 percent.

A study looked at the value of forecasting weather variable inputs and energy optimization algorithms for commercial building energy systems. It was found that weather variables are a significant component of building energy systems and minimizing the uncertainty in weather predict can lead to energy reductions of 15–30 percent compared to a deterministic and non-weather sensitive controls. (Lazos, 2014) Another study

also shows that the quality of the predicted weather data is important to guarantee reliable results (Oldewurtel, 2012)

Another paper (Petersen, 2014) looked at the effects of weather forecast uncertainty on energy use and indoor climate of a building that uses a model predictive control. The effects are quantified by comparing the simulation with differences in forecasted and actual weather data. The effects were identified through a differential sensitivity analysis of four building design parameters: orientation, thermal mass, solar shading and window area. The analysis was performed using Danish weather data from two different years. The results from the simulation study showed a potential for energy savings and improvements in thermal indoor environment despite the uncertainty in the weather forecasts. Buildings with heavy thermal mass were less dependent on the accuracy of the weather forecasts compared to buildings with very light thermal mass. The performances of the light thermal mass buildings were especially sensitive to the precision of solar irradiance forecasts.

A simple summary of the literature review is that high mass buildings perform better than low mass buildings in modeled predictive control and accurate weather forecasts make the predictions more accurate but high mass buildings are less sensitive to forecast inaccuracies than low mass buildings.

2.0 SIMULATION

2.1. Simulation procedure

A simple direct gain passive solar building (Fig. 1) with two occupants was modeled in Energyplus 8.2 for one full year in Boston, Massachusetts. The zone had dimensions of 4 meters by 7 meters by 3 meters high. The only window was on the south façade and the size of the window was held constant at 70 percent of window to wall ratio. A south facing shading device can be varied in size. The floor was an insulated concrete slab of variable thickness and the interior walls and ceiling was covered with gypsum. The insulation level of the walls, ceiling and slab were varied. Ventilation was achieved by an air to air heat exchanger.

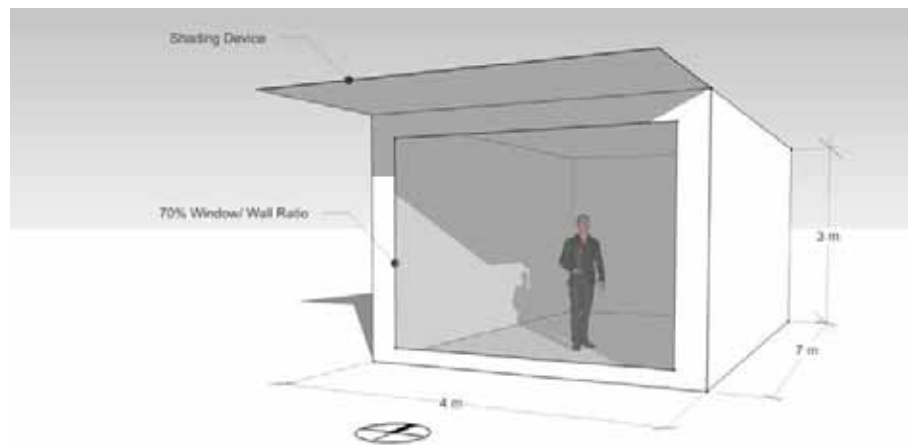

Figure 1: Simple direct gain model simulated.

Five building parameters were changed (Table 1) to see their effect on the indoor comfort level. First, the building insulation level of the walls, ceilings and floor was changed from a conductance of (0.5, 0.25, 0.17, 0.13, 0.10, 0.08) W/m^2 . The zone operative temperature for each conductance was plotted and compared. Holding the conductance at 0.08 w/m^2 , the south facing window type was changed from double clear argon to triple clear argon to quadruple clear argon. The zone operative temperature from each window type was plotted and compared. Next the concrete floor thickness was increased from 0.05 m to .25 m in 0.05 m increments. The zone operative temperature was compared and the floor thickness was then held at 0.15 m thick. Two formulations of a phase change material were placed in the ceiling of the building. Both have a heat capacity of 575 $W \times hr/m^2$ and a melting point of 27° C and 21° C. These results were plotted. The floor thickness was then held at 0.15 m thick and the phase change material was removed. The shading device was added and increased in length from 0.5 to 2.5 m in 0.5 m increments. The zone operative temperature

was plotted and the shading device was held at 1.5 m length and then the ventilation was changed from (0.6, 1.25, 1.75, 2.50, 3.0) air changes per hour. Ventilation was achieved using an air-to-air heat exchanger with 80 percent efficiency. These results were plotted.

Table 1: Simulation parameters

Boston, MA EPW-TMY3 Latitude 42.37 Longitude -71.02 NS length (m) 7 EW length (m) 4 Height (m) 3 South Window/Wall 70% Occupants 2		SIMULATION NUMBER																											
		1	2	3	4	5	6	7	8	9	10	10a	10b	11	12	13	14	15	16	17	18	19	20	21	22	23	24	25	26
Insulation Level																													
	0.50 W/m2-k	x																											
	0.25 W/m2-k	x																											
	0.17 W/m2-k		x																										
	0.13 W/m2-k			x																									
	0.10 W/m2-k				x																								
	0.08 W/m2-k					x	x	x	x	x	x	x	x	x	x	x	x	x	x	x	x	x	x	x	x	x	x	x	x
Window Type (SHGC, U)																													
	Double Clear Argon (0.76, 2.56)	x	x	x	x	x	x																						
	Triple Clear Argon (0.69, 1.62)						x																						
	Quadruple Clear Argon (0.62, 1.20)							x	x	x	x	x	x	x	x	x	x	x	x	x	x	x	x	x	x	x	x	x	x
Concrete Floor Thickness																													
	0.05 m	x	x	x	x	x	x	x	x																				
	0.10 m								x																				
	0.15 m									x	x	x				x	x	x	x	x	x	x	x	x	x	x	x	x	x
	0.20 m															x													
	0.25 m																x												
Ceiling PCM																													
	Melting 27, Capacity 182										x																		
	Melting 21, Capacity 182											x																	
Shading Device Length																													
	None	x	x	x	x	x	x	x	x	x	x	x	x	x	x														
	0.50 m																x												
	1.00 m																	x											
	1.50 m																		x										
	2.00 m																				x								
	2.50 m																					x							
Ventilation Rate (ACH)*																													
	Constant=0.60																												
	Constant=1.25																												
	Constant=1.75	x	x	x	x	x	x	x	x	x	x	x	x	x	x	x	x	x	x	x									
	Constant=2.50																												
	Constant=3.00																												
Predicted Ventilation Rate (ACH)*																													
	Before Prediction=1.75																												
	After Prediction=0.60																												
	After Prediction=1.25																												
	After Prediction=1.75																												
	After Prediction=2.50																												
	After Prediction=3.00																												

* With 80% efficient Heat Exchanger

2.2. Simulation results

The results of the simulation were plotted (Fig. 2) showing the zone operative temperature for a four-day period from February 18th to February 21st. These four days were chosen because the direct solar radiation was high on the 18th, followed by two days of very low direct solar radiation and then the 21st has high direct solar radiation in the EPW weather file that was used for the simulation. The comfort zone is plotted using ASHRAE 55, PMV method for operative temperature and a maximum predicted mean vote of 10 percent. The low comfort limit of 18.5 °C uses a CLO value of 1.49 and a MET of 1.0. The high limit of 27.4 °C uses a CLO value of 0.5. The results show that all of the simulations were within the comfort zone for some time period during the four-day span. The simulations with high mass were in the comfort zone for the most amount of time during the four-day time period. The single plot was broken up into four individual plots to clarify the effect of changing each of the parameters.

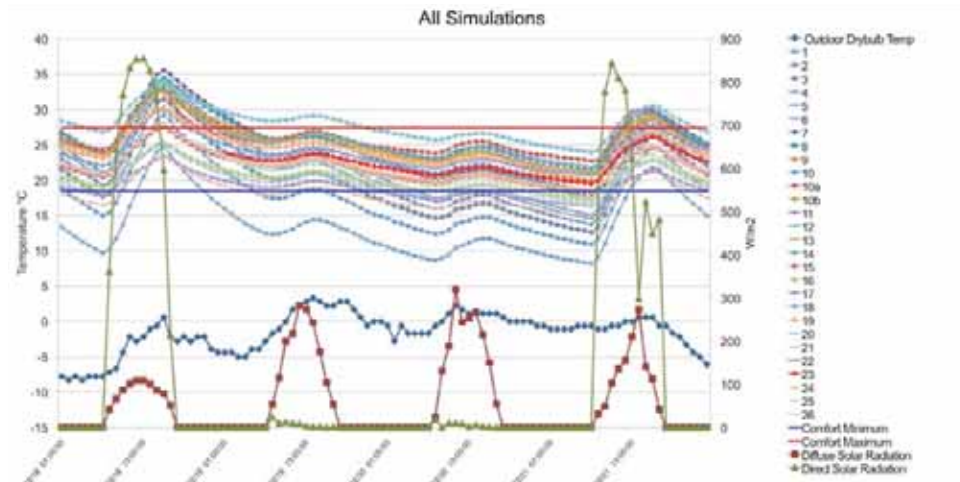

Figure 2: Zone operative temperature, outdoor temperature and radiation for all simulation runs over four day period.

Changing the insulation level and glazing type (Fig. 3) did not produce remarkable results, lower conduction at the envelope had higher zone operative temperatures, except for the change from triple clear argon glazing to quadruple clear argon glazing. This change had nearly the same zone operative temperature however the quadruple clear argon glazing had a lower maximum zone operative temperature and a higher minimum zone operative temperature than the triple clear argon glazing.

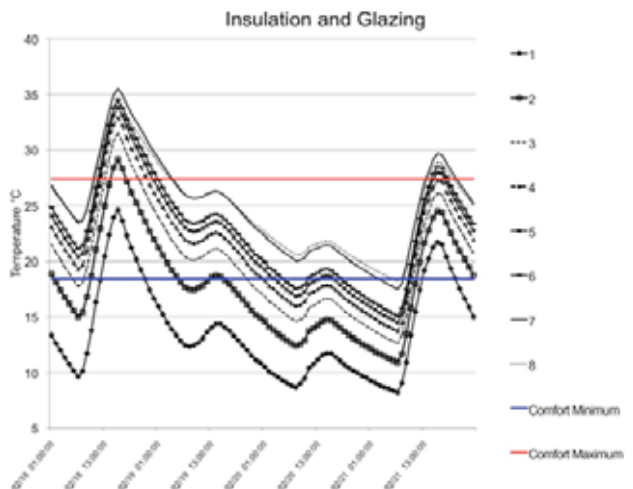

Figure 3: Zone operative temperature for changes in insulation and glazing over four-day period.

The mass and phase change materials results (Fig. 4) show the zone operative temperature swing, both daily and weekly, decreased as the thickness of the slab increased, as expected. When phase change material is added to the ceiling the formula with a melting point of 27° C has the best result since the phase change material with a melting point of 23° C would remain liquid over the four day period so it has little effect on the zone operative temperature. Shading (Fig. 5) and ventilation changes also performed as expected.

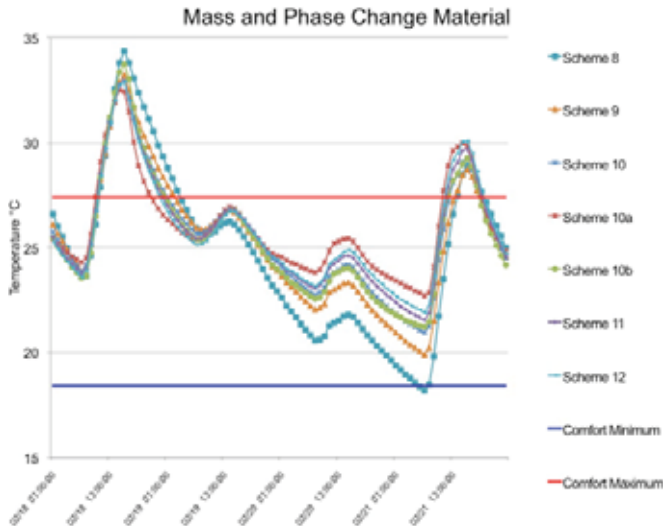

Figure 4: Zone operative temperature for changes in mass and phase change material over four-day period.

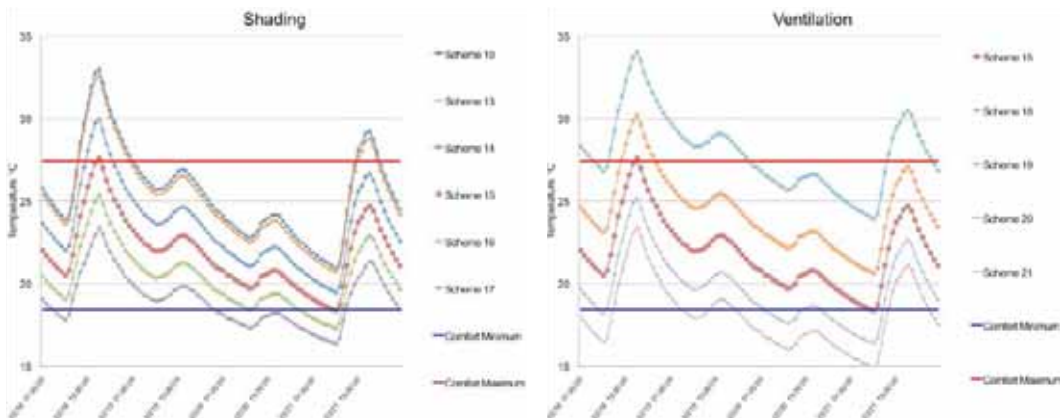

Figure 5: Zone operative temperature for changes in shading and ventilation over four-day period.

2.3. Predictive modeling simulation test

The simulation results show that changing the parameters will change the zone operative temperature in scale and in profile. The parameters that are the easiest to change are shading and ventilation. A simple test for predictive modeling is performed by changing the ventilation rate for the direct gain passive solar building for a period of two consecutive days of low solar radiation during the heating season. A weather file in the EPW format was analyzed and two consecutive days of low direct solar radiation were found on February 19th and February 20th. The advantage of a weather file compared to real weather is the fact that the proceeding days weather is known in a weather file while real weather forecasts must be predicted. Knowing that the direct solar radiation would be low for two consecutive days, the ventilation rate was changed in the simulation by five different rates (Fig. 6) to observe possible zone operative temperatures. Scheme 22 gave the best results for comfort. In a building controlled by predictive modeling, the ventilation rate could be changed at midnight on the evening before the start of the two consecutive days of low direct solar radiation and the building would remain comfortable. In a building controlled by a thermostat, the ventilation would probably not be changed, scheme 24 has a constant ventilation rate, until it fell to the lower end of the comfort zone and might need supplemental heating to bring the zone back into the comfort zone.

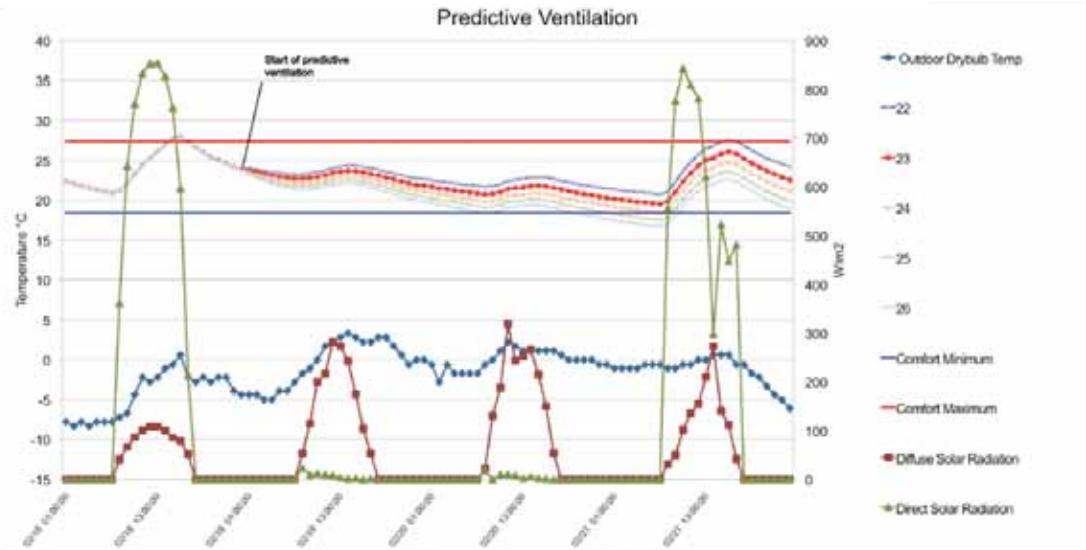

Figure 6: Zone operative temperature for predictive ventilation over four-day period.

CONCLUSION

The results of the initial simulation are encouraging but more study is needed. The next steps will be to simulate predictive control over a whole year for thermal comfort and to develop rules for controlling ventilation and shading based upon predicted weather. The potential of predictive modeling and automated building facade elements to attain thermal comfort does look promising.

REFERENCES

- Afram, Abdul, and Farrokh Janabi-Sharifi. 2014. "Theory and Applications of HVAC Control Systems – A Review of Model Predictive Control (MPC)." *Building and Environment* 72 (February): 343–55.
- Chen, T. Y. 2002. "Application of Adaptive Predictive Control to a Floor Heating System with a Large Thermal Lag." *Energy and Buildings* 34: 45–51.
- Feng, Jingjuan (Dove), Frank Chuang, Francesco Borrelli, and Fred Bauman. 2015. "Model Predictive Control of Radiant Slab Systems with Evaporative Cooling Sources." *Energy and Buildings* 87 (January). Elsevier B.V. 199–210.
- Lazos, Dimitris, Alistair B. Sproul, and Merlinde Kay. 2014. "Optimisation of Energy Management in Commercial Buildings with Weather Forecasting Inputs: A Review." *Renewable and Sustainable Energy Reviews* 39 (November): 587–603.
- Oldewurtel, Frauke, Alessandra Parisio, Colin N. Jones, Dimitrios Gyalistras, Markus Gwerder, Vanessa Stauch, Beat Lehmann, and Manfred Morari. 2012. "Use of Model Predictive Control and Weather Forecasts for Energy Efficient Building Climate Control." *Energy and Buildings* 45 (February): 15–27.
- Petersen, Steffen, and Katrine Wieck Bundgaard. 2014. "The Effect of Weather Forecast Uncertainty on a Predictive Control Concept for Building Systems Operation." *Applied Energy* 116 (March): 311–21.

Urban climate change impacts on building heating and cooling energy demand

Pravin Bhiwapurkar¹

¹Kent State University, Kent, OH

ABSTRACT: The challenges of warming urban climate on building energy needs for space conditioning are discussed by assessing the impact of intra-urban microclimatic changes, also called as urban heat island (UHI). This paper presents the results of a simulation study on the energy consumption for heating and cooling of a small-office building within intra-urban microclimatic conditions of the Chicago metropolitan area. The urban development influences: land-use land-cover and anthropogenic heat by buildings, industry, and transportation and the lake effect that modify climatic conditions are reflected in the weather files selected from five locations in the study area. The study simulated a small-office building per ASHRAE Standard 90.1-2013 with typical construction, heat gains and operational patterns with a whole building energy simulation program eQuest 3.65 for selected locations. The results confirm that heating load decreases, and cooling load and overheating hours increase as the office location moves from rural (less developed) to urban (developed) sites however, these changes are influenced by the distance from the downtown and the Lake Michigan. It is shown that prominent intra-urban climatic variations are an important factor affecting energy performance. The paper presents detailed results of the typical small-office placed within intra-urban climatic zones of the metropolitan area, arguing the necessity to consider using weather files based on UHI for the design of current buildings to safeguard their efficiency in the future.

KEYWORDS: Urban Climate, Heat Island Effect, Building Energy

INTRODUCTION

Urban areas modify their climate (Arnfield 2003) due to high rates of urbanization that resulted in drastic demographic, economic and land use changes. These modifications include increasing temperature, changing wind speeds, precipitation patterns, cloud cover, and solar irradiance. The most significant modification is the creation of Urban Heat Islands (UHI) which refers to elevated temperature over urban (developed) areas compared to rural (less developed) areas. UHI is more prominent during nighttime when wind speed is relatively lower than daytime wind speeds. The paved urban surfaces like streets, sidewalks, parking lots and building and its configurations are crucial in the formation of UHI because it reduces evapotranspiration due to loss of vegetation. When studied using satellite thermal infrared images (Lo, Quattrochi, and Luvall 1997) surface heat island is more prominent where the albedo and emissivity properties of paved urban surfaces is often intensified and vertical surfaces is often ignored. The role vertical urban surfaces like building facades plays within dense urban environment is brought forward by Sky View Factor (SVF) (Oke 1988, Erell, Pearlmutter, and Williamson 2011) of the urban canyon. In addition, geography, topography, large bodies of water, land use, population density and physical layout of the urban area influence UHI (Oke 1987). The rapidly expanding urban boundaries constantly modify rural landscape and the nature of constantly evolving urban landscape varies per land-use land cover changes. The increasing anthropogenic heat contribution of the urban environment is significant (Stone, Hess, and Frumkin 2010, Sailor 2011) and it includes waste heat from buildings, industries, and transportation (Sailor 2011). Therefore this paper focuses on and emphasizes the need to recognize intra-urban climatic conditions to inform building heating and cooling energy needs.

UHI modify microclimatic conditions, increase air pollution (Hankey, Marshall, and Brauer 2012) and exacerbate heat waves in urban areas (Stone, Hess, and Frumkin 2010). Heat related mortalities are observed globally (McMichael, Woodruff, and Hales 2006) and in particular, 1995-96 Chicago heat wave and 2003 European heat wave is most reported in the literature. As the frequency of heat waves is increasing, the mortality rates are decreasing where use of air conditioners is prevalent (Bobb et al. 2014, O'Neill 2005, Davis et al. 2003). The increased use of air conditioners to counterbalance warming effect subsequently increase building waste heat contribution from buildings and such practices adds warmth to the urban environment. Although, warm urban condition reduces building heating energy needs, it increases cooling energy needs and internal heat load dominated buildings operated during day time, like office buildings, are significantly affected. Therefore, the major contribution of UHI is the increased summertime peak electric demand (Akbari and Konopacki 2005) that adds burden on the existing power infrastructure and increases GHG emissions.

Further, most UHI studies linking building energy needs presents air temperature as the climatic variable for its energy impact and suggest increased vegetation and increased albedo of pavements and roof for energy savings (Akbari and Konopacki 2005). Studies have also reported air temperature and relative humidity for its impact on heating and cooling energy needs (Kapsomenakis et al. 2013). The prevalence of nighttime

UHI is often associated with lower nighttime wind speed that prevents transportation of urban heat absorbed during the daytime by urban thermal mass allowing it to rise above the city. While urban and building material properties are important, its organization within urban form (Bhuiwapurkar 2007) is critical for nighttime urban cooling and night flushing is a commonly suggested energy saving strategy for warming climate (2012). However, variation in day and nighttime UHI, especially in the case of Chicago metropolitan area, is not well established with promising evidences (Coseo and Larsen 2014). Also, UHI studies are often reported during clear sky conditions with low wind speed and both these conditions are constantly changing through the year. To account for combined influences of the urban environment and climatic influences, on building space conditioning energy use especially in view of synoptic weather conditions of the great lakes region by seeking answers to questions such as:

- Do intra-urban or microclimatic variations exist in the study area and how does it vary seasonally?
- How do intra-urban microclimatic changes influence peak building energy use and peak demand?

2.0 METHODS AND MATERIAL

2.1. Context

As reported by Coseo and Larsen (2014), Chicago metropolitan area lies on the flat Lake Michigan plain (41°52' North and 87°37' West with minimal elevation changes of 176.5 m (579 ft.) to 205.1 m (673 ft.) above sea level (USGS, 2012). Chicago, Illinois, has a moderate continental climate with an average mean air temperature from May to September of 25.9°C (1961–1990) (Hayhoe, Sheridan, Kalkstein, & Greene, 2010). In July and August, prevailing west-southwest (240°) winds average 13.2 km/h (8.2 mph) (1981–2010) transporting in warm humid air from the central and southern plains (Angel 2014).. Tree cover plays an important role in moderating air temperatures in the region. McPherson and colleagues (1997) found that the city of Chicago had an average tree canopy of 11%. Street trees comprised 10% of the total canopy in the city. According to Imhoff and colleagues (2010), Chicago falls within a grassland bioclimatic region. Another important contextual factor is Chicago's location on the west side of Lake Michigan. While the 2010 population of the Chicago-Joliet-Naperville metropolitan statistical area was 9,461,105, the city of Chicago's population was 2,695,598 residents (US Census, 2012). In 2010, Chicago had an average population density of 45.7 persons per ha (18.1 persons per acre) within the city limits. Researchers suggest that Chicago's current UHI patterns are likely to intensify with a warming climate and further urbanization in the region (Hayhoe et al., 2010; Vavrus & Van Dorn, 2010). This will significantly alter Chicago's micro-climate and increase its vulnerability to ecological and financial risks (Weinstein and Turner 2012).

The typical UHI effect is often studied under calm wind conditions on clear sunny days (Figure 1) in which urban heat rises above the built environment and raises air temperature of the downtown area. In contrast, the Chicago heat island often appears in the western suburbs, not in the Downtown Area (Gray and Finster 2004). The lake wind influences transport of urban heat over the west side development (Figure 2 (a)). Gray and Finster (2004) reported an average about 3-5°F temperature gradient between Lisle (located between 2 and 5 in Figure 2) and Downtown Chicago in the summer months (June-August) during 1992-1996.

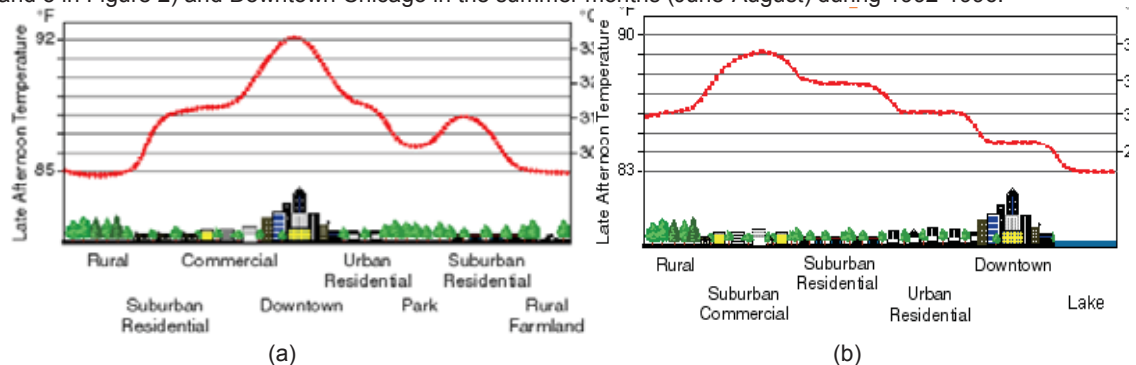

Figure 1: (a) Typical urban heat island profile under calm wind conditions (b) Chicago's heat island profile (Gray and Finster 2004)

2.2. Climatic data: sources and suitability

The National Climatic Data Center (NCDC) monitored weather stations are selected for investigating climatic variations in the Chicago metropolitan area for quality purposes (Figure 2). These stations are located at varying distances from the Lake Michigan: Waukegan (3.37 miles), Midway (9 miles), O'Hare (13.5 miles), DuPage (31.5 miles) and Aurora (45 miles). The hourly climatic data obtained from these five weather stations in TMY-3 format (Wilcox and Marion 2008) are suitable for this study as it reflects combined influences of land-use/land cover changes, related anthropogenic heat from buildings, transportation, and

automobiles, and the lake effect. In this way, the interaction of climatic variables and urban landscape is well accounted for predicting energy needs.

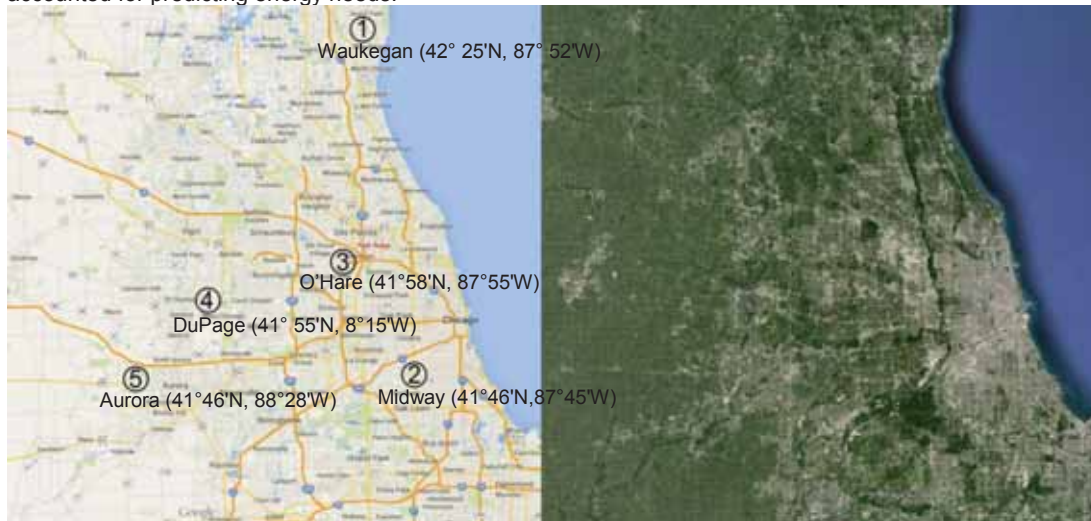

Figure 2: Climatic data collection locations (Google Maps) and LandSAT Image of the Chicago metropolitan area showing urbanized to rural landscape pattern (Google Earth).

2.3. Physical model characteristic

A representative 3-storied, small-sized office building (CBECS 2012) of 1366 m² (14,700 ft²) is modelled per ASHRAE Standard 90.1-2013, Climatic Zone:5A (ASHRAE 2013) and Appendix G requirements to estimate energy needs. The building footprint of 21.30m x 21.3m (70' x 70') is chosen for orientation neutrality (Thornton et al. 2010) in which 40% of the area is allotted for open office, 30% for enclosed/private office, 10% for corridor, 5% for conference room and remaining areas include printing/photocopying room, stairwell, and electric/mechanical rooms. The perimeter and core zoning pattern is adopted for energy modeling purposes and perimeter zone depth is 3.65m (12'). The floor to floor height is 3.96m (13') and clear floor to ceiling space is 2.74m (9'). The floor to floor glazing of 40% (27% for floor to ceiling) is equally distributed on all sides and includes internal blinds that are 20% closed during occupied hours and 80% closed when unoccupied. Building opaque constructions in the small- and medium-sized office prototype include mass walls, flat roof with insulation above the deck and slab-on-grade floors. Windows are defined as manufactured windows in punch style openings. These envelope constructions represent common practice for small-office buildings in the U.S. (CBECS 2012, Richman et al. 2008) and are followed in the study. The building operating hours are from 8am-5pm, Monday-Friday, and are closed on Standard Holidays in the US. Following (Table 1) building characteristics are used for energy estimation purposes.

Table 1: Spec office building characteristics.

Envelope		Lighting (w/ft ²)	
Roof	R-30ci (albedo 0.4, light)	Office (open/enclosed)	0.98 /1.11
Walls	R13+R10ci	Conference Room	1.23
Slab on grade	R-15 for 24in	Restroom	0.98
Door	U-0.5	Corridor	0.66
Fenestration	U-0.42,	Mechanical	0.42
	SHGC-0.4	Copying Room	0.72
	VT-1	Plug loads	0.75 (Mercier 2011)(p3)

The baseline HVAC system for this building type and size, and climatic zone (5A) adopts ASHRAE 90.1-2013 Appendix G suggestion on use of (System3: PSZ-AC) constant volume packaged rooftop air conditioner. The space is conditioned by a packaged single zone DX system with furnace. The efficiency of packaged unit, EER, is 10 and furnace minimum efficiency is 80%. Also, the natural gas non-residential domestic hot water system is modeled at 80% efficiency. The HVAC system maintains a 23.8°C (75°F) cooling set point and 21.11°C (70°F) heating set point during occupied hours. During off hours, thermostat set point is 27.77°C (82°F) for cooling and 17.77°C (64°F) for heating. The economizer is set to maximum DB temperature 70F.

2.4. Comparison method

The distance from the Lake Michigan and distance from the Downtown are significant factors for intra-urban microclimatic variation. Among selected locations, Waukegan is less urbanized, less populated location and it is closer to the lake. It is far north of the Downtown and it is not influenced by the UHI. The west side

developments where summertime UHI influences are significant hosts other study locations. The variations in UHI and related building heating and cooling energy needs on the west side locations are compared with Waukegan location.

Climatic changes: The temperature influences of UHI among selected locations are compared seasonally and particularly during the extremely hot week identified per NCDC. The summer months are particularly crucial due to increase in cooling related peak electric demand and energy. The summer months considered in this study are July-September whereas winter months are January-March. The autumn and spring months are represented by October-December and April-Jun respectively. The extremely hot week is from July 15-21 and the extreme winter week is from February 12-18. The average temperature of seasonal months is used to compare seasonal UHI. The average hourly temperature data is used to compare day and nighttime UHI. The day and nighttime hours are decided based on available global horizontal solar radiation which is the sum of direct normal irradiance, diffuse horizontal irradiance, and ground-reflected radiation.

Annual energy use: A whole energy simulation program, eQUEST 3.65 (DOE, 2013) has been previously validated for its algorithm and published elsewhere, and is considered suitable for this study (see Bhiwapurkar and Moschandreas, 2010) to estimate energy performance of the small-office building which is kept constant through the study. This allowed for focused investigation on shifting heating and cooling energy due to changing climate by keeping lighting, plug loads, and other energy needs constant through the study. The weather files collected from the five stations in the Chicago metropolitan area are used to estimate intra-urban variations in Energy Use Intensity (EUI), peak electric demand, annual electric and heating energy use. The variations in intra-urban HDD and CDD are also included in the study.

3.0 RESULTS AND ANALYSIS

3.1. Intra-urban climatic changes

There is a significant variation in average seasonal temperatures among all locations in Chicago metropolitan area. The average seasonal temperature includes hourly day and nighttime temperature for three months. The highest average temperature of 23.52°C is observed during summer months at Midway and the lowest temperature of 20.6°C is observed at Waukegan (Table 2). The temperature trends are opposite during winter months; DuPage (1.01°C) and Midway (-0.85°C) are warmer compared to Waukegan (-2.18°C). During spring months, DuPage (15.95°C) is reporting highest temperature and Waukegan (13.42°C) being the lowest in the group. Although, the average temperatures are lower at all location in autumn, Midway reported highest temperature at 7.13°C and Aurora is showing lowest among the group at -1.41°C. In general, average seasonal temperatures at Waukegan are lowest, thus it is a reasonable assumption for baseline case when comparing intra-urban UHI.

The highest seasonal intra-urban UHI variation among four locations is observed during autumn months (October-December) and the lowest temperature variations are observed during spring months ranging from 1.42°C at Aurora to 2.53°C at DuPage. When average temperatures are compared with Waukegan, the variation ranges from 3.76°C at Midway to -1.41°C at Aurora. The negative temperature difference is representing a cool island effect. This variation is consistent with the distance from the Lake Michigan as well as the Downtown area. Thus, average wind direction and speed was analyzed at these locations. The average wind direction at Midway, O'Hare, DuPage and Aurora is from Southwest to Northwest direction. The combined influence of wind direction and speed seem to minimize temperature gradient across the east-west axis although industrial land use and high percentage of paved areas exists on west side developments (Konopacki and Akbari 2002, Gray and Finster 2004). Based on this observation, it is expected that the Downtown area remains warmer during autumn months although Downtown specific measurements will provide insights on such a claim.

Table 2: Seasonal UHI variation within Chicago metropolitan area (°C).

	Waukegan	Midway	O'Hare	DuPage	Aurora
T (avg. summer)	20.60	23.52	21.34	20.54	21.44
ΔT (summer)		2.92	0.75	-0.05	0.85
T (avg. winter)	-2.18	-0.85	-1.11	1.01	-1.37
ΔT (winter)		1.33	1.07	3.19	0.81
T (avg. spring)	13.42	15.48	15.46	15.95	14.84
ΔT (spring)		2.06	2.04	2.53	1.42
T (avg. autumn)	3.37	7.13	4.00	3.89	1.96
ΔT (autumn)		3.76	0.63	0.52	-1.41

The summertime UHI intensity of 2.92°C is highest at Midway and the west side locations, DuPage and Aurora, are showing marginal difference of -0.05°C and 0.85°C when compared with Waukegan location (Table 2). When compared with Midway locations, the temperatures at O'Hare, DuPage, and Aurora are

cooler by 2.18°C, 2.98°C, and 2.08°C. The lowest average summer temperature at DuPage is the most surprising result as this location is on the west side and it is closest to the center of heat island reported by Gray and Finster (2004). This summertime temperature trends, like autumn observations, are not following previously published trends of warmer climate on west side development. One of the significant influences is the prevailing west-southwest wind that averages 13.2 km/h transporting in warm and humid air from the central and southern plains (Angel 2014) does not support the UHI phenomenon presented in Figure 1(b). In addition, while the major water body can provide summertime cooling the location of the lake downwind from the prominent southwest wind may lessen its effect. The lake's cooling influence also wanes in late summer when water temperature can reach as high as 26.7°C

The UHI effect is reported during day as well as night time. Table 3 summarizes day and night time averaged temperatures. The maximum seasonal day and night temperature difference (1.95°C) is observed at Aurora during summer, followed by spring (1.14°C), autumn (1.48°C), and winter (0.61°C) months. Similar pattern is followed by DuPage, O'Hare, and Midway showing lowest changes. Waukegan shows minimal change during winter and autumn month (1.91-2.1°C) while spring and summer months show temperature differences in the range of 3.44°C-3.76°C respectively. Table 2 and Table 3 provided averaged temperature differences of the season. In order to investigate non-averaged temperature differences, this study delves into extremely hot week.

Table 3: Average Day and Night time UHI variation.

	Waukegan	Midway	O'Hare	DuPage	Aurora
T (summer day-night)	3.76	3.02	4.20	4.54	5.71
ΔT (summer day-night)		-0.74	0.44	0.78	1.95
T (winter day-night)	2.10	1.64	2.16	2.45	2.71
ΔT (winter day-night)		-0.47	0.06	0.35	0.61
T (spring day-night)	3.44	2.70	4.41	4.30	4.58
ΔT (summer day-night)		-0.74	0.44	0.78	1.95
T (autumn day-night)	1.91	2.06	2.47	3.38	3.39
ΔT (autumn day-night)		0.15	0.56	1.47	1.48

The extreme summer week varies per location so an overlapping period of two weeks from July 13-26 is considered for this analysis. During this time, the maximum daytime temperature (40.0°C) is recorded at Midway on July 24 (with standard deviation of 12.81°C). This record temperature is reflected in the overlapping peak demand for the building on the same day for Midway location. Similarly, high daytime temperature is increasing peak electric demand, although dates vary among selected location. The highest day and night temperature difference is observed at Aurora (19.00°C) followed by Waukegan (15.20°C), Midway (14.00°C), O'Hare (13.30°C) and DuPage (13.00°C). The weekly average day and night temperature difference is highest at Aurora (13.00°C) followed by O'Hare (10.64°C), DuPage (10.31°C), Midway (9.21°C) and Waukegan (9.06°C). The higher night time temperature that minimizes day and night time differences is an indication of night time UHI. When compared with Waukegan, Midway is showing high nighttime UHI and Aurora is showing minimum nighttime UHI. (Kolokotroni et al. 2012) suggests warm nighttime temperature can improve nighttime ventilation opportunities in office building for warming climate. The warm nighttime urban temperature may potentially increase use of air conditioners during evening hours, especially in residential buildings. However, spring and autumn month might benefit most from natural ventilation as an energy saving strategy. Since currently studied small-office building is operating during daytime (8am-5pm), this discussion focuses on daytime hours and following section explores the UHI influences on predicted energy needs.

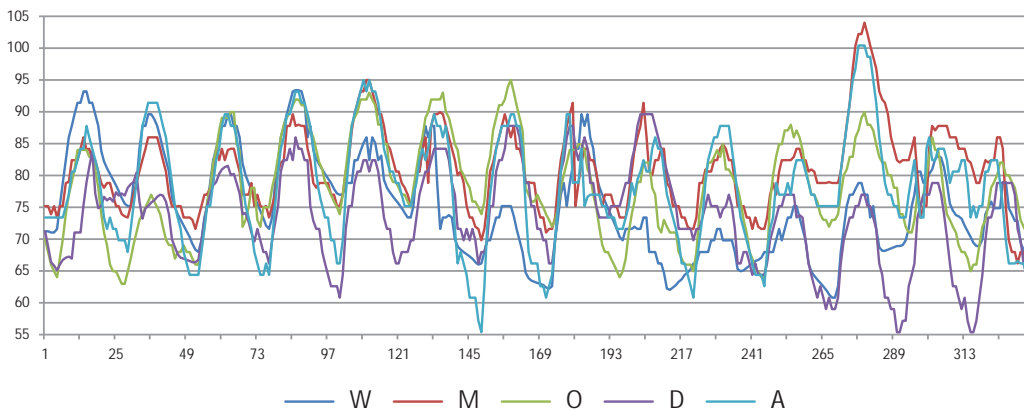

Figure 3: Extreme summer week, July 13-26 (change temperature scale from °F to °C).

The variation in intra-urban climatic conditions is changing annual heating and cooling degree days for each location as shown in Table 4. Midway location represents the most modified urban climate and it is observed in highest CDD (691) and lowest HDD (3106) among other locations. In comparison to Waukegan, Midway has 70% higher CDD and 17% lower HDD. While CDD and HDD are representative of climatic zone and does not account for specific building condition that may have unique indoor climatic conditions, the building cooling and heating hours vary significantly. The small-office building investigated in this study, shows 21% increase in building cooling hours and 22% decrease in building heating hours for Midway location. These changes are mainly due to external and internal gains. It is important to note that improved energy efficiency criteria of ASHARE 90.1-2013 allows for less building cooling hours (21%) however, it needs further study.

Table 4: Annual heating and cooling degree days.

	Waukegan	Midway	O'Hare	DuPage	Aurora
CDD (18°C baseline)	407	691	506	523	444
Increase in CDD*		284 (70%)	99 (24%)	116 (29%)	37 (9%)
Building Cooling Hours	877	1065	1098	1097	1072
Increase in Building Cooling Hours		188(21%)	221(25%)	220(25%)	195(22%)
HDD (18°C baseline)	3747	3106	3430	3300	3629
Decrease in HDD*		-641(-17%)	-317(-8%)	-447(-12%)	-118(-3%)
Building Heating Hours	1329	1042	1188	1137	1133
Decrease in Building Heating Hours		-287(-22%)	-141(-11%)	-192(-14%)	-196(-15%)

* Changes in CDD and HDD in relation to Waukegan location

3.2. Building heating and cooling energy use

The annual building energy needs (gas, electric, and peak demand) of a 3-storied office building for selected locations in Chicago metropolitan area are discussed. For quality checks, the EUI at O'Hare location was compared with CBECS (2013) data for small buildings and then with EUI published by Pacific Northwest National Laboratory (PNNL) study on a small-office building (Thornton et al. 2010) (Table 5.5) that utilized similar weather file. The EUI estimated at O'Hare location in this study (26.75 KBtu/ft²) is lower than published PNNL study (27.40 KBtu/ft²) that applied advanced energy saving strategies. This change is in fair agreement for small-office buildings because PNNL study adopted ASHRAE 90.1-2004 and applied Advanced Energy Design Guide for Small Office Buildings available that time.

The highest EUI (6.863 kWh/ft²-yr) is observed for Midway location whereas the lowest EUI (6.559 kWh/ft²-yr) is reported at Waukegan location. The simulation results for EUI at OHare (6.781 kWh/ft²-yr) and Aurora (6.796 kWh/ft²-yr) locations are very similar whereas EUI (6.825 kWh/ft²-yr) at DuPage location it is slightly higher which is similar to Midway location. The annual electric energy needs shown in Figure 4(a) follows the similar trend. The energy consumption categories are lights, miscellaneous equipment (plug loads), space cooling, pumps and auxiliary, and ventilation fans in the building. The building energy consumption at Midway location is highest at 100,879kWh compared to the Waukegan at 96,424kWh. O'Hare and Aurora locations are showing similar results at 99,682kWh and 99,899kWh respectively.

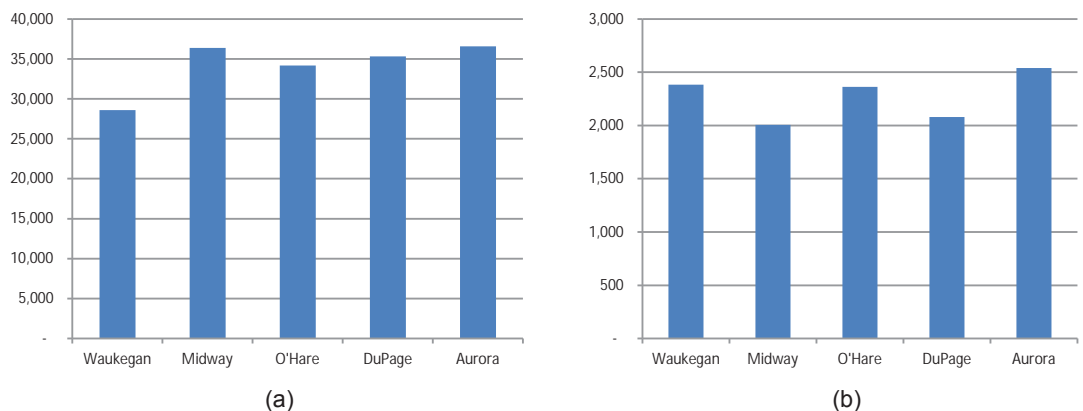

Figure 4: (a) Annual cooling energy (kWh) (b) Annual heating energy (Therms).

The cooling energy (kWh) needs are 34%-37% of the total electric needs of the building. When annual cooling energy needs among these locations are compared with Waukegan (Figure 4(a)), the energy needs are higher and cooling energy needs is emerged as the most fluctuating energy category. In this category, the small-office building at Aurora (28%) is consuming highest energy, and it is followed by Midway (27%),

DuPage (24%), and O'Hare (19%). These variations are significant and affecting overall EUI. Also, it is surprising to note that Aurora location is consuming higher cooling energy than Midway location. Main reason for such fluctuations is location is warm daytime starting conditions due to nighttime UHI as well as daytime UHI that is influenced by wind speed and directions in the metropolitan area. Further, cloud cover plays an important role in the amount of global solar radiation received at these locations. Figure 5(a) shows average hourly global horizontal solar radiation received at selected locations through the year. Aurora receives highest solar radiation (386 w/m²) whereas Midway (200 w/m²) receives almost half the radiation because of high cloud cover. This is affecting external heat gain at Midway location compared to Aurora while internal heat gain remains constant for all locations.

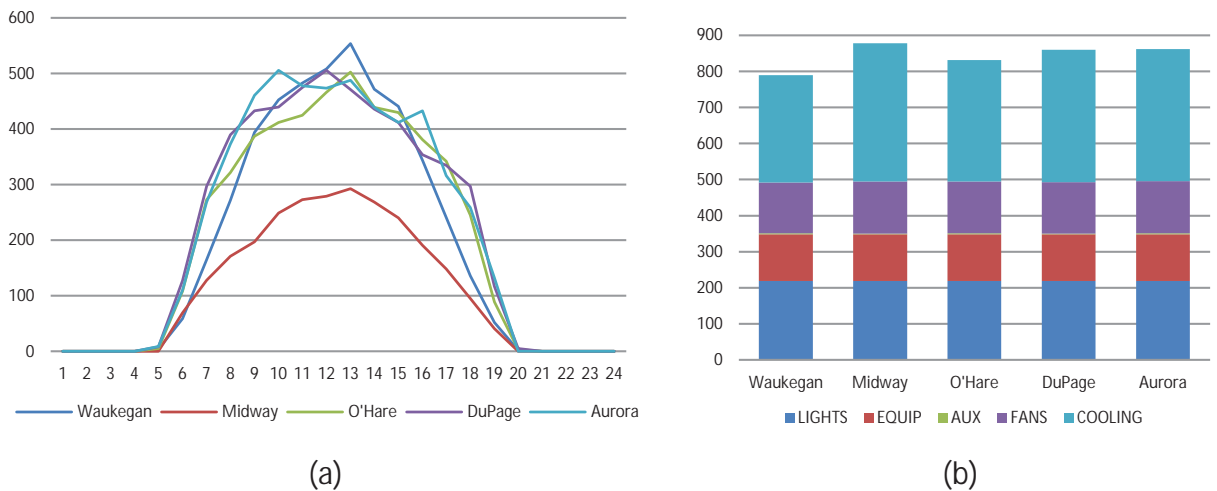

Figure 5: (a) Average hourly global solar radiation (w/m²) (b) Annual peak demand (kW) distribution by major categories.

The cooling related peak electric demand is significant. Annually, it constitutes 41-44% of the total electric demand except for Waukegan (38%). This contribution increases to 52%-56% during summer months and 46%-51% and 39%-44% during spring and autumn months respectively. Midway location required 56% of the peak energy for cooling during summer, which is not very different than Aurora (55%), DuPage (54%) and even O'Hare (52%). One of the major influences of climate change is increased extremes hot and cold weather events. This is observed during spring and autumn months as early heat waves are reported in April and the late heat waves are observed in October (reference). Early warming trends in spring are showing significant cooling related peak demand where Aurora and O'Hare locations need 51% peak demand for cooling and Midway and DuPage are at 49% and 46% respectively. During autumn months, Midway location shows highest cooling energy contribution towards peak demand.

High heating energy needs at Waukegan location (2382 Therms) is not surprising because of its proximity to the Lake Michigan. The lake tends to increase cloudiness in the area and suppress summer precipitation. Winter precipitation is enhanced by lake-effect snow that occurs when winds blow from the north or northeast. These winds allow air to pass over the relatively warm lake, boosting storm system energy and water content, and leading to increased snowfall. Similarly, far west side location of Aurora is showing high (2539 Therms) heating energy needs as north or northeast winds does not seem to be influenced by urban heat: combination of land-use land-cover, and anthropogenic heat sources, that are decreasing heating energy needs at Midway and DuPage locations.

The lake effect is significantly influencing building energy needs; especially at Waukegan which is closest and Aurora is the farthest from the Lake Michigan. Also, it is observed that the variations in energy needs are not consistent among studied locations. There is no direct relationship of cooling energy needs and UHI in the study area because UHI can change wind speed and wind direction and lake effect transport air mass with high moisture content. These in fact influences received solar energy by the urban surfaces and its interaction with boundary layer climate. While the lake can provide some summertime cooling, the prominent southwest wind may lessen its effect. The Lake's cooling influence also wanes in late summer when water temperatures can reach as high as 26.7°C (80°F).

These intra-urban climatic changes modified CDD and HDD. In comparison to Waukegan, Midway, DuPage, and Aurora showed increase in CDD by 70%, 24%, 29%, and 9% respectively while decreased by 22%, 11%, 14%, and 15% at Midway, O'Hare, DuPage and Aurora respectively.

The changes in CDD and HDD modified building energy use. The annual cooling energy needs increased by 27%, 19%, 24%, and 28% at Midway, O'Hare, DuPage, and Aurora respectively in relation to the cooling related peak energy demand increased by 20.62%, 1.69%, 5.12%, and 14.24% at O'Hare, DuPage, and Aurora. In contrast, heating energy needs decreased by 16%, 1%, 13% at Midway, O'Hare, DuPage, and Aurora locations respectively. The cooling energy needs is most affected by the microclimatic variation and it is reported to reach up to 52-56% of the total building

This study provides evidences on existing intra-urban climatic changes and its influences on energy needs. This study for a great lake city is applicable for other lake cities and it is useful for climate resilient strategies that will safeguard energy efficiency of future buildings.

REFERENCES

- Akbari, H., and S. Konopacki. 2005. "Calculating energy-saving potentials of heat-island reduction strategies." *Energy Policy* 33 (6):721-756. doi: 10.1016/j.enpol.2003.10.001.
- Angel, Jim. 2014. "Climate of Chicago - Description and Normals." Accessed <http://www.isws.illinois.edu/atmos/statecli/general/chicago-climate-narrative.htm>.
- Arnfield, A. John. 2003. "Two decades of urban climate research: a review of turbulence, energy and water, and the urban heat island." *International Journal of Climatology* 23 (10):1002/joc.859.
- ASHRAE. 2013. *ANSI/ASHRAE/IES Standard 90.1-2013 -- Energy Standard for Buildings Except Residential Buildings*. 2013: ASHRAE.
- Bhiwapurkar, Pravin. 2007. "Urban Heat Island Phenomenon, Urban Morphology, and Building Form: The Case of Chicago." Ph.D., Architecture, Illinois Institute of Technology.
- Bobb, Jennifer F., Roger D. Peng, Michelle L. Bell, and Francesca Dominici. 2014. "Heat-Related Mortality and Adaptation to Heat in the United States." *Environmental Health Perspectives* 122 (10):1289/ehp.1307392.
- CBECs. 2012. "Commercial Buildings Energy Consumption Survey 2012." Energy Administration of the United States Department of Energy Accessed <http://www.eia.gov/consumption/commercial/reports/2012/preliminary/index.cfm>.
- Coseo, Paul, and Larissa Larsen. 2014. "How factors of land use/land cover, building configuration, and adjacent heat sources and sinks explain Urban Heat Islands in Chicago." *Landscaping Planning*:117.
- Davis, Robert E., Paul C. Knappenberger, Patrick J. Michaels, and Wendy M. Novicoff. 2003. "Heat-Related Mortality in the United States." *Environmental Health Perspectives* 111 (10):1718.
- Erell, Eviatar, David Pearlmutter, and T. J. Williamson. 2011. *Urban microclimate : designing between buildings*: London ; Washington, DC : Earthscan, 2011.
- Gray, K., and M. E. Finster. 2004. The Urban Heat Island, Photochemical Smog, and Other Features of the Problem and Solutions.
- Hankey, Steve, Julian D. Marshall, and Michael Brauer. 2012. "Health Impacts of the Built Environment: Within-Urban Variability in Physical Inactivity, Air Pollution, and Ischemic Heart Disease." *Environmental Health Perspectives* 120 (2):247-253.
- Kapsomenakis, J., D. Kolokotsa, T. Nikolaou, M. Santamouris, and S. C. Zerefos. 2013. "Increase of the air ambient temperature in Greece: The impact on buildings." *Energy and Management* 74:353-365.
- Kolokotroni, M., X. Ren, M. Davies, and A. Mavrogianni. 2012. "London's urban heat island: current and future energy consumption in office buildings." *Energy and Buildings* 47:30-40.
- Konopacki, S., and H. Akbari. 2002. *Energy Savings of Heat-Island Reduction Strategies in Houston*. Berkeley, CA: Environmental Energy Technologies Division, LBNL, Uni. of California.
- Lo, C. P., D. A. Quattrochi, and J. C. Luvall. 1997. "Application of high-resolution thermal infrared sensing and GIS to assess the urban heat island effect." *International Journal of Remote Sensing* 18 (2):287-304.
- McMichael, A. J., R. E. Woodruff, and S. Hales. 2006. "Climate change and human health: future risks." *Lancet* 367 (9513):859-869.

- Richman, Eric E., Emily M. Rauch, Jaclyn N. Phillips, Kimberly A. Petty, Jessica Knappek, and Priscilla L. Lopez-Rangel. 2008. National Commercial Construction Characteristics and Compliance with Building Energy Codes: 1999-2007. Pacific Northwest National Laboratory (PNNL), Richland, WA.
- Sailor, D. J. 2011. "A review of methods for estimating anthropogenic heat and moisture emissions in the urban environment." *International journal of climatology* 31 (2):189.
- Stone, Brian, Jeremy J. Hess, and Howard Frumkin. 2010. "Urban Form and Extreme Heat Events: Are Sprawling Cities More Vulnerable to Climate Change Than Compact Cities?" *Environmental Health Perspectives* 118 (10):1425-1428.
- Thornton, BA., W Wang, Y. Huang, MD. Lane, and B. Liu. 2010. Technical Support Document: 50% Energy Savings for Small Office Buildings. Pacific Northwest National Laboratory.
- Weinstein, Michael P., and R. E. Turner. 2012. *Sustainability science [electronic resource] : the emerging paradigm and the urban environment / Michael P. Weinstein, R. Eugene Turner, editors*: New York : Springer, c2012.
- Wilcox, Stephen, and William Marion. 2008. *Users manual for TMY3 data sets*: National Renewable Energy Laboratory Golden, CO.

COMPUTATIONAL
D E S I G N

Practical energy and cost optimization methods for selecting massing, materials, and technologies

Sandeep Ahuja¹, Patrick Chopson¹, John Haymaker¹, Godfried Augenbroe¹

¹Georgia Institute of Technology, Atlanta, GA

ABSTRACT: Available energy analysis and optimization methods do not produce fast and accurate enough results to provide guidance to professional design teams making massing and technology decisions. This paper proposes two methods using the reduced-order Energy Performance Calculation (EPC) toolkit with parametric building models and optimizers in Rhinoceros, Grasshopper and MATLAB to provide rapid feedback that gives architects more confidence in their decision between alternatives on energy and cost performance. The first method helps architects to understand and optimize the performance of a set of building massing parameters through an energy demand analysis. The second method seeks to optimize for lowest life cycle cost combinations of material and technology parameters that meet or exceed operational energy efficiency targets. The methods are compared with existing prescriptive methodologies, and tested as part of a professional office building design process to demonstrate how they can quickly and accurately lead an architectural design team to improvements in energy performance and construction cost.

KEYWORDS: Optimization, Energy, Cost, Practice, Parametric

INTRODUCTION

Design objectives such as program, construction cost, environmental performance and aesthetics are key factors in an architectural design. Conceptual design decisions, about a building's orientation, massing, materials, components, and systems largely determine lifecycle performance with respect to these objectives. Currently, these decisions are made based on a limited set of tested alternatives (Ellis et al. 2008). Research shows that successful designs require an early understanding of such objectives and the ability to explore and analyze a large number of alternatives (Kelly 2006; Suh 1995). However, with multiple objectives and constraints, the design space quickly becomes unmanageable (Simon 1969). Therefore, in many cases, limited time and budget constrains the set of design options that can be tested during conceptual design. These process deficiencies can often lead to design solutions with poor initial and lifecycle performance (Clevenger et al, 2013). Figure 1 illustrates the "MacLeamy Curve" (MacLeamy, 2004), where curve 1 shows that the ability to vary functionality and cost is high at the beginning of the design process, and gradually decreases towards the detailed design stage. An inverse relationship can be observed with curve 2, denoting the high cost of change in later stages of design. Curve 4, models the methodology that the authors are proposing, to focus on the early stages of design where there is the highest impact, and lowest additional cost incurred for changes in the design. In traditional practice, curve 3, slow communication between architect and engineer delays decisions, making it difficult and expensive to incorporate the engineer's suggestions to the design. However, to achieve high performance targets such as the 2030 Challenge (architecture2030.org), design teams are finding it important to pursue rigorous integration at the early design stage.

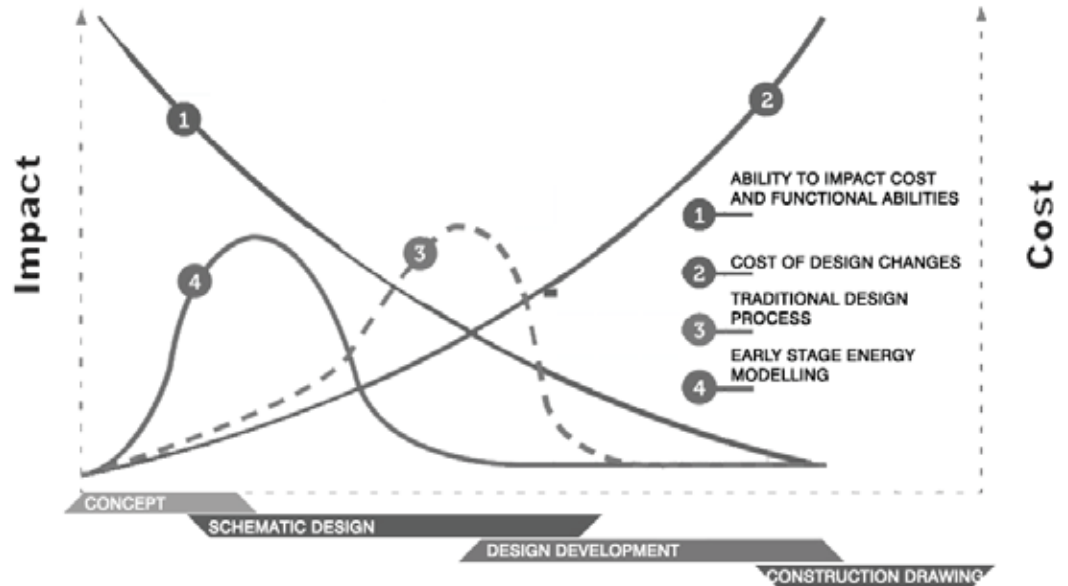

Figure 1: Macleamy's curve describes the high cost of decisions made late in the design process.

A	CONCEPT DESIGN	SCHEMATIC DESIGN	DESIGN DEVELOPMENT	CONSTRUCTION DOCUMENT
DESIGN TEAM	Client and site research initial programming and massing Concept generation	Revised massing Envelope, structure and systems options	Revised design with Envelope, structure and HVAC systems	Final design with Envelope, structure and HVAC systems
ENGINEER			MEP + structure alternatives Materials alternatives study Detailed dynamic simulation	Final MEP + structure design Code compliant dynamic simulation
INTERIOR DESIGNER			Interior layout and design	Interior layout and design
CONTRACTOR		Initial Cost Estimate	Detailed Cost Estimate	Final cost estimate

B	CONCEPT DESIGN	SCHEMATIC DESIGN	DESIGN DEVELOPMENT	CONSTRUCTION DOCUMENT
ENERGY ANALYST	Massing alternatives study	Massing alternatives study Materials alternatives study Cost Vs Energy optimization	Materials alternatives study Cost Vs Energy optimization Detailed dynamic simulation	Engineer co-ordination for code compliant dynamic simulation
DESIGN TEAM	Client and site research initial programming and massing Concept generation	Revised massing Envelope, structure and systems options	Revised design with Envelope, structure and HVAC systems	Final design with Envelope, structure and HVAC systems
ENGINEER			MEP + structure alternatives Materials alternatives study Detailed dynamic simulation	Final MEP + structure design Code compliant dynamic simulation
INTERIOR DESIGNER			Interior layout and design	Interior layout and design
CONTRACTOR		Initial Cost Estimate	Detailed Cost Estimate	Final cost estimate

Figure 2: A: the authors' representation actors and processes and inter-relationships over time in 'typical' commercial building design process. B: Suggested variation to the current practice to achieve higher energy and cost performance.

Figure 2A depicts our observations of a somewhat typical design process for commercial buildings in the Atlanta office of our firm. During interviews with architects in our offices, we found that, consistent with recent observations (Gane & Haymaker 2010), key factors that lead to decision making in conceptual and

schematic design are experience, budget, client preferences, and aesthetics with limited attention given to energy demand. To meet increasingly stringent energy codes and soaring client aspirations, designers need to integrate energy performance into their conceptual decision making processes. This requires tools that are fast and accurate enough to provide useful guidance while also keeping pace with fluid design spaces and limited budgets.

Once a design team has moved forward from the initial massing stage and after considering various alternatives and selecting a smaller list of options, they proceed to the next stage of the design where they make material and technology choices. The manufacturers of building materials, systems and technologies continue to create larger palettes of products with varying performance and cost. This variety allows for a vast array of alternatives available for buildings resulting in a very large number of technology combinations. For example, given 16 technology types, each with 3 possible options for performance and cost choice, would yield to 4.3 million unique combinations. When a contractor and architect collectively select from these options, they are unable to perceive all of choices and their impacts collectively. This leads to making inefficient selections in terms of either energy or cost or both. (Simmons et al, 2013)

Figure 2B adds a swim lane showing how parametric energy analysis can be integrated into the various steps and stages of design process. This allows feedback to the designer where it has the highest chance of being incorporated due to a low cost of design change. Dealing with the issue at the conceptual design stage, this paper offers a method to parametrically generate and test variable design options using optimization to select energy and cost efficient massing, materials, and technologies.

Our method delivers speed with accurate enough results by allowing the comparison of alternatives against each other with the confidence that we are evaluating on a level playing field. It should be noted that accuracy is not in regards to the energy consumption of the built project, but rather the relationship between alternatives is accurate (Kim, 2013). We define fast as a method that easily delivers relative rankings with low computation time along with the least possible amount of uncertainty (Kim, 2013).

We first discuss the parametric design approaches applied to enable the systematic generation of a space of design alternatives. Next, we describe analysis and optimization processes for optimizing the building massing, and then the material and system selections. We conclude by describing the application of these processes on an industry case study, and discussing how these processes can impact the efficiency and effectiveness of conceptual design processes.

1.0 PARAMETRIC DESIGN SPACE

The first step of the overall process utilizes parametric modeling to represent geometric entities with editable attributes, and associative relationships. Attributes can be expressed by independent values, which act as input to the model, or be dependent on other attributes in the model. Variations of these inputs generate different solutions of the model.

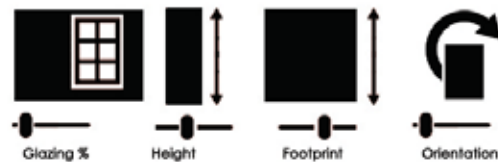

Figure 3: Common geometrical parameter for commercial office building.

Parametric models consist of variables and constraints. Variables are the primary drivers of geometric variations. We distinguish between two types of variables: *independent* and *dependent*. An independent variable is a user defined numeric input whose value can actively be controlled and changed while the dependent variable is the output whose value changes as a result. Constraints help delineate the range of variations that a parametric model can sustain. The extent of the range and the exact outcome of each geometric variation will be determined by the type of constraints used in the geometry definition process (Barrios, 2005). Figure 3 demonstrates the definition and variation of a typical parametric design space for a commercial office building.

2.0 MASS OPTIMIZATION

Reducing energy demand is a key early design consideration in architecture today. In this paper, the energy demand analysis of the building design is calculated using an energy performance calculation (EPC) toolkit developed by the Building Technology group at Georgia Institute of Technology. The EPC is a quasi-steady state model that approximates energy flows in a building at the macro level. It is based on a simplified description of a building and ignores detailed dynamic effects (Augenbroe et al, 2013). This simplified tool

can quickly generate a comparison between the design options and the ASHRAE 90.1 baseline buildings. The use of this normative calculation is chosen instead of a dynamic simulation tool on two counts:

1. A set of normative modeling assumptions makes the method transparent thereby greatly reducing the potential for possible modeler's bias.
2. By using normative usage scenarios, the calculation only focuses on how the building behaves under assumed conditions (Lee et al, 2012), allowing EPC to be a strong comparative tool to study the impacts of varying geometrical parameters in the building.

The authors created a component in the Honeybee/Ladybug (Roudsari, 2015) plug-in that allows the geometry component in the EPC calculator to be directly linked in the parametric design space of Grasshopper. The definition allows the designer to set varying building parameters outputting different window to wall ratios, ceiling heights, length vs width, orientation, overhangs, internal shading, and photovoltaics panels to interpret their impact on the building energy performance. The plug-in separates the geometries by walls, surface, and roof. The walls are further segmented into opaque or glazed areas based on their properties. The surface area of each of these building geometries contribute to the heat flowing in and out of the building and hence the energy demand. These surface geometries are then separated into 8 possible directions (North, Northeast, East, Southeast, South, Southwest, West, and Northwest). These surface directions yield differences in the energy demand with the change in orientation. Since the EPC calculator requires the building geometry to be collapsed in these 8 directional categories, even the most complex design case can be simplified into an 8 sided box, greatly simplifying the modeling and analysis inputs.

Most of the geometrical inputs into the EPC are controlled by variables dependent on each other. For example, the parameter connected to the building height directly enters the EPC calculator to represent any change in building height. In simple geometries, the height parameter is also used in conjunction with the area of the floor plate to enter the volume input. The change in overhang depth is modelled by capturing the angle formed between the center of the window and the top of the overhang. The changing depth can be classified into four overhang angle ranges less than 30, 30 - 44, 45 - 59 and more than 60. See Figure 4 for illustration of the inputs for overhangs, fins, and horizon angle.

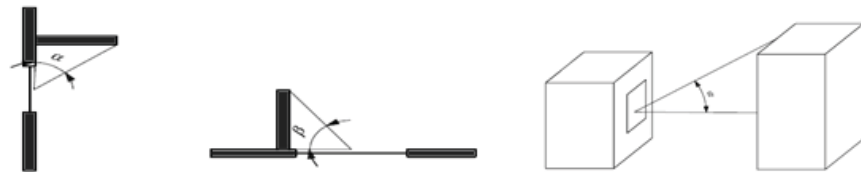

Figure 4: Showing the external shading factor calculation.

When a new design is constructed, these parameters are constrained to meet the site conditions and any other restrictions based on the client and design intent. They are then prioritized with respect to each other to determine which parameter should be the major driver of the design. Once, the priorities have been set, the various parameters are sent to "Galapagos", an optimization script (Simmons 2012) in grasshopper. It uses the energy analysis from EPC calculator to determine the combination of values yielding to the lowest energy demand. This allows us to test a wide range of building massing options and selecting a range that can be further explored to meet other design objectives. Along with the geometric option that can be varied in the grasshopper interface, other parameters that can be adjusted inside of EPC can be seen in figure 5.



Figure 5: Author graphical representation of editable parameters in the EPC excel interface.

3.0. MASS OPTIMIZATION CASE STUDY

A practical application of the process currently under discussion is a new office building near Columbia, SC. This project is led by a progressive design principal and typifies a type of practice where small agile teams work in an iterative fashion to realize the collective design goal.

The project began with discussions with the client about their goals as an organization and understanding their current needs. This tied directly into choices about concept, site, and massing. Incorporating energy

early into this process, Figure 6 demonstrates how the design team iterated over multiple massing ideas looking for the driving factors in the design. The lead two authors, acting as energy analyst on the team, provided feedback regarding the impact of various building footprints, orientation and glazing percentages (option 1-8) that the design team generated. Since energy impacts of design decisions are often counterintuitive, the design team found they could enhance the design by rotating the building by 17 degrees off the true North/South orientation to reduce the energy demand by 7%. In contrast to a detailed energy model, the team was able to test multiple glazing percentages by orientation in a single day, 8 working hours.

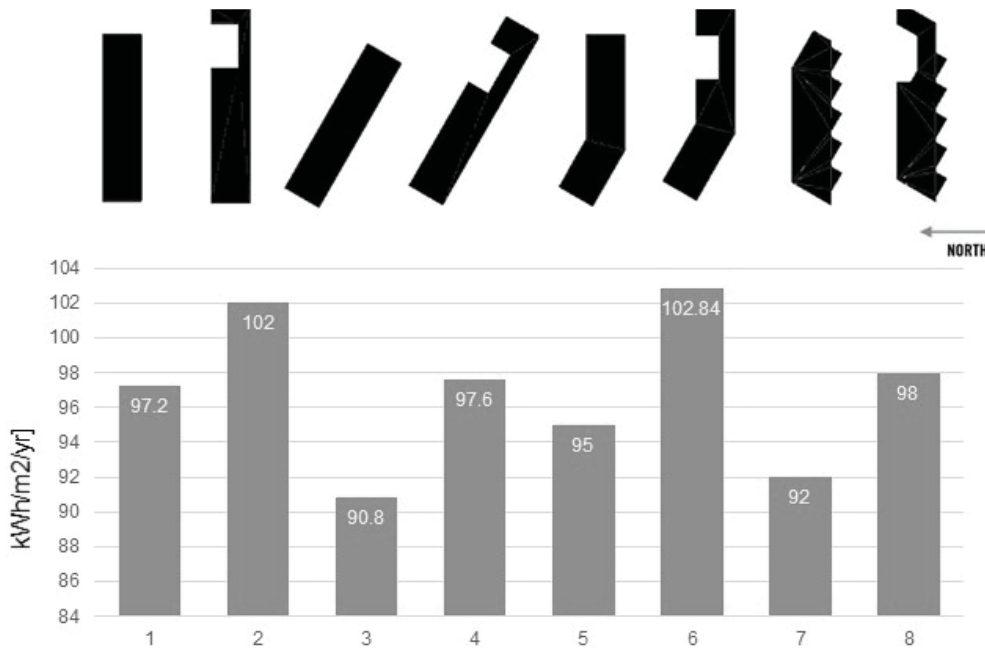

Figure 6: Representation of varying energy demand with varying massing.

The team went back to the client with the strategies generated giving them the confidence that the team possessed firsthand knowledge. This energy feedback proved vital to defining and tracking the client's energy goals for the project. As the design continued to progress, the energy model kept pace, allowing the tracking of performance across design decisions. The parametric energy analysis process and embedded energy modeling experts in the project team supported the fluid nature of the process by providing feedback on designs with fluctuating levels of detail.

4.0 MATERIAL AND TECHNOLOGY OPTIMIZATION

The material and technology optimization method, developed by the Building Technology group at Georgia Institute of Technology, searches the discrete combinatory space by maximizing the objective function: calculated energy savings divided by premium cost. The algorithm is codified into a custom MATLAB script and when compared to prescriptive methodologies is shown to be much more cost effective and can be applied given a range of building technology alternatives and their corresponding cost data (Simmons 2012).

This method also utilizes the EPC as the underlying energy engine for finding the optimal mix of technologies. The resulting EPC calculation tool is used by the optimization algorithm to evaluate the combinatorial space of technology parameters. It should be stressed that the optimization problem is only well posed at the whole building level. As a consequence, optimality can only be defined at the whole building energy outcome level (Augenbroe, 2011).

Optimization requires a metric to rank the effectiveness of each combination. Simmons et al, 2013) developed a method to rank designs for energy using a cost versus percent energy savings metric. The challenge in the past is that analysing the thousands of combinations of options for a typical building required days of calculations using EnergyPlus. By using the EPC and a custom MATLAB script developed at Georgia Tech, one can harness the computationally light EPC to run thousands of combinations in as little as an hour. Thus, we have both a metric and a methodology that can be used in the fast paced world of architecture.

In this methodology, all of the inputs in the EPC are available for optimization by considering each technology option with its performance and associated cost above a baseline case. The baseline case here is considered to be the case which meets the ASHRAE 90.1 baseline. While performance values are easy data to get from manufacturers, cost data is more difficult to find. Construction cost varies from region to region and often from city to city due to transportation and labour costs. Close coordination with the contractor is the most effective means of finding true cost data. However, RS Means or other construction cost database can also be used. Typical inputs to optimize include: Daylight controls; Occupancy sensors; Constant illumination controls; HVAC system type; Heat recovery methods; Exhaust air recirculation methods; Envelope tightness; Hot water fuel type; Building energy management systems; Photovoltaic type and amount; Lighting fixture type ; Appliance efficiency; Roof type; Wall type; Glazing type; and Solar hot water collector.

Within each category the design team can include as many options as they like. A design space of 16 parameters has 170 million possible combination. The optimization routine solves for these combinations by using a combined ascent and descent method (Simmons 2012). The algorithm increases the cost and percent energy savings until it reaches the target percentage. Once there, it backtracks minimizing cost while maintaining the percentage reduction. Close coordination between the architect, contractor, and mechanical engineer ensures that the options under consideration have accurate energy vs cost information.

5.0 MATERIAL AND TECHNOLOGY OPTIMIZATION CASE STUDY

To illustrate the use of this method, we collaborated with a senior project designer and his team to analyze a 156,000 square foot, 8-story office building in Charleston, SC as a case study. As communicated by the design team, this project near the river had employed the rule of thumb approach to come up with a design. All selections were highly typical of office building construction in the Southeast to maximize the functionality of the design. The building is a typical cast in place concrete structure with a continuous glass facade on all sides. As designed, the office building performed just slightly better than the ASHRAE 90.1 2013 baseline. Running the material and technology optimization process on this building yielded to an additional cost of \$883,065 for a 60% energy performance improvements as compared to the ASHRAE 90.1 2013. Since the overall estimate for the building was \$27 million, a 60% (4.03 Kwh/sqft) reduction in energy was achieved for 3.3% increase in the estimated cost. With the current price of electricity approximated at 9 cents/kwh, this meant a payback time of 10.4 years. The estimated payback time is likely to decrease with the rise in electricity costs in the upcoming years demonstrating the achievable impact of this process from an energy and business perspective.

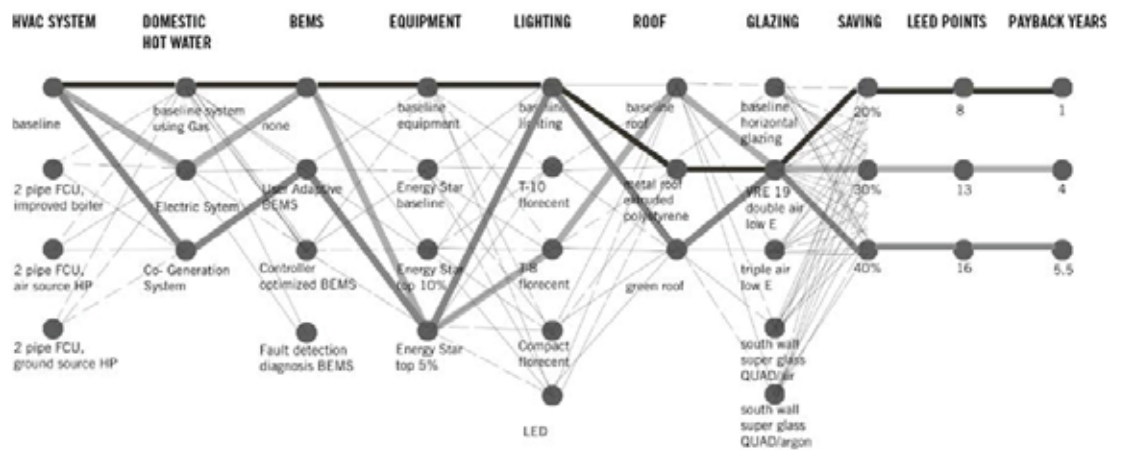

Figure 7: Possible energy savings for cost and energy optimized material and technology options. Three possible options out of the total 50,000 options are presented by the darker lines.

CONCLUSION

Emerging tools like Rhinoceros and Grasshopper are enabling integrated modules and scripting environments that are narrowing the gap between architects, engineers and computer programmers. This paper looks at emerging design tools and the current process and begins to test where parametric enabled energy analysis processes might be efficient enough to provide effective design guidance.

The rapid feedback method can use optimization to create a design space to select materials and technology options while balancing cost versus percent energy savings. Building upon this first step, the mass optimization process enabled the generation and analysis of orders of magnitude more design

alternatives. Thus allowing the exploration of designs that were substantially more energy efficient than those typically evaluated using current methods at negligible additional process cost.

The material and technology optimization allowed the design team to analyze 186 more material and technology combinations than the typical 3 to 4, for a 60% energy savings and 8 years payback time at minor additional process cost. This can yield highly accurate and useful results with an accurate and diverse cost estimate. Since contractors often offer only one material and technology pricing option, the material and cost optimization is approximated using industry standard cost estimating tools like RS Means. Future suggestions include proposing the creation of an integrated contractor and mechanical engineering team to allow for more accurate inputs to increase the accuracy of the optimization process and reduce any duplication of work.

Contemporary parametric design, analysis, and optimization tools give us the possibility to enhance multidisciplinary communication and design exploration. However, to date, these methods have resided in domain specific tools and required computational and engineering design experts to formulate the models, meaning these models have taken too long and been too expensive to be effectively applied in the early stages of design. The methods in this paper match the design iteration speed of architects providing high performance building decisions to be integrated with design from the very beginning of a project.

ACKNOWLEDGEMENTS

We would like to thank Architect Bruce McEvoy, Senior Project Designer & Principal, and Andrew Blocha, Senior Project Designer & Associate Principal for their collaboration on this study.

REFERENCES

- "Architecture 2030: The 2030 Challenge." Architecture 2030. Web. 05 Feb. 2015.
- Augenbroe G. 2011, "The Role of Simulation in Performance Based Building." in *Building Performance Simulation for Design and Operation*, Abingdon, Oxon: Spon Press.
- Barrios C. 2005. "Transformations on Parametric Design Models", *Computer Aided Architectural Design Futures*, Vienna: Springer: 393–400.
- Clevenger, C.M., Haymaker, J.R., and Ehrich, A. 2013. "Design exploration assessment methodology: testing the guidance of design processes," *Journal of Engineering Design*, Vol. 24, No. 3: 165–184.
- P.G. Ellis, P. A Torcellini, and D. B. Crawley. 2008, "Energy design plugin: An EnergyPlus plugin for SketchUp." Rep. No. NREL/CP-550- 43569, National Renewable Energy Laboratory, Washington, DC.
- Gane V, Haymaker J, Fischer M, and Bazjanac V. 2013. "Application of Design Scenarios Methodology to Evaluate the Effectiveness of Transparent Parametric Design Spaces," American Society of Civil Engineers: accessed October 26, 2014, [http://dx.doi.org/10.1061/\(ASCE\)AE.1943-5568.0000116](http://dx.doi.org/10.1061/(ASCE)AE.1943-5568.0000116)
- Gane V and Haymaker J. 2013. "Conceptual design of high-rises with parametric methods," *Predicting the Future*, 25th eCAADe Conference Proceedings, 293-301. (2013): accessed October 26, 2014.
- Gane, V. and Haymaker J. 2010. "Benchmarking Conceptual High-Rise Design Processes." *Journal of Architectural Engineering*, 16(3), 100-111.
- Kelley, D. 2006. "Design Thinking," accessed November 26, 2014,
- Kim J., Augenbroe G., and Suh H. 2013. "Comparative Study of the LEED and ISO-CEN Building Energy Performance Rating Methods." Proceedings of BS2013: 13th Conference of International Building Performance Simulation Association, Chambéry, France, August 26-28: accessed October 26, 2014.
- Lee S. 2012. "Management of Building Energy Consumption and Energy Supply Network on Campus Scale", PhD diss., Georgia Institute of Technology, College of Architecture.
- MacLeamy P. 2014. "Project Effort and Impact", accessed November 21st, <http://www.buildingsmartsd.org/>
- Turrin M, Stouffs R and Sariyildiz S. 2013. "Finding The Cost-Optimal Mix of Building Energy Technologies That Satisfies a Set Operational Energy Reduction Target," Proceedings of BS2013: 13th Conference of International Building Performance Simulation Association, Chambéry, France, August 26-28: accessed October 26, 2014.
- Turrin M, Stouffs R, and Sariyildiz S. 2013. "Performance-based Parameterization Strategies: A theoretic framework and case studies," Open Systems: Proceedings of the 18th International Conference on Computer-Aided Architectural Design Research in Asia (CAADRIA 2013), 519–528: accessed October 26, 2014.
- Roudsari, M. "Ladybug + Honeybee." Grasshopper. N.p., n.d. Web. 05 Feb. 2015. <http://www.grasshopper3d.com/group/ladybug>
- Simmons B. 2012. "Lowest Cost Building Technology Selection for Energy Efficient Design", Master's Thesis, Georgia Institute of Technology, College of Architecture.

- Simmons B, Tan M, Wu J, Yu Y, Augenbroe G. 2013. "Finding The Cost-optimal Mix of Building Energy Technologies That Satisfies A Set Operational Energy Reduction Target", paper presented at the 13th International Building Performance Simulation Association Conference. Chambéry, France.
- Simon H. 1969. *The Sciences of the Artificial*, Cambridge, MA: Massachusetts Institute of Technology
- Suh N. 1995. "Axionmatic Design of Mechanical Systems", *Journal of Vibration and Acoustics*, ASME 17:1-10, 1995
- Welle B, Haymaker J, Fischer M, and Bazjanac V. 2011. "CAD-Centric Attribution Methodology for Multidisciplinary Optimization Environments: Enabling Parametric Attribution for Efficient Design Space Formulation and Evaluation," *American Society of Civil Engineers*, 2011: accessed October 26, 2014, [http://dx.doi.org/10.1061/\(ASCE\)CP.1943-5487.0000322](http://dx.doi.org/10.1061/(ASCE)CP.1943-5487.0000322)
- Wetter M. 2012. "Simulation-Based Building Energy Optimization", PhD diss., University of California, Berkeley.

Another approach to space

Dennis Lagemann¹

¹ETHZ / D-ARCH / ITA / CAAD, Zurich Switzerland

ABSTRACT: What if computation could do more than just deliver increasingly intriguing geometries? What if computation could offer us a look at the spaces that are conceivable but not yet imaginable: computed as pure information topologies. Metrical space, especially geometrical space could then be rendered into this relational framework.

Life-Design of urban society has changed during the last decades. New media have entered our perception to a degree never imagined by future sciences of the past. So the question if space-time can still be considered as a single layer in reality arises in philosophy, physics... and Architecture? And for urban society? Individualization takes command. Being special becomes normality. Programs inhabit spatialities, people work and dwell and make company in short, due to increasing nomadism and fluctuation.

Three protagonists are sent in for discussion. Alberti, who is deemed to have created the modern image of 'the Architect', Ledoux, who might best be described as a cultural engineer, preceded shape and transformation grammars and Habraken who reminds us that the ordinary may create spaces far more appropriated than any Architect will ever be able to invent.

But in urban areas, where the life plans of many intersect but should not collide, where comfort should be provided on limited and affordable space, the question arises if these appropriations are still appropriate, whether stacking and adding single use areas in uniform grammars can still be the answer. Maybe the everyday use of space already does find answers Architecture did not yet take into account.

KEYWORDS: Computation, Active Space, Quantum Paradigm

INTRODUCTION

In his text "Questions That Will Not Go Away" Habraken quotes Alberti to point out that the Albertian Turn in his sense was the secession of the intellectual planner dealing with the proportionate 'Lineamenta' from the medieval master-builder dealing with the shaping of material.¹ He furthermore argues that the urban fabrics we perceive as beautiful were mainly done without Architects, but appeared as continuous fields in a specific socio-cultural environment and in a regional tradition of craftsmanship. The appearance of Architecture in the 'common urban or rural fabric' has been a phenomenon since modernism, when new materials were developed that were in demand for a skilled planner. Before this, the application of Architecture was reserved to extraordinary tasks, such as religious or communal buildings or the residences of the Maecenas. But if we take a look at the following citations from Alberti's Ten Books, we may at least ask ourselves if this was really intended by the 'Architect':

If Beauty therefore is necessary in any Thing, it is so particularly in Building, which can never be without it, without giving Offence both to the Skillful and the Ignorant. How are we moved by a huge shapeless ill-contrived Pile of Stones? The greater it is, the more we blame the Folly of the Expense, and condemn the Builder's inconsiderate Lust of heaping up Stone upon Stone without Contrivance.²
How many Towns, which when we were Children, were built of nothing but Wood, are now lately started up all of Marble?³

The application of valuable materials undoubtedly raises the necessity for a skilled planner and so does the organization of complexity. But maybe it was never an intention of the Architect to exclude the ordinary, as Alberti explicitly states that beauty was necessary in anything. Another protagonist, less well-known but no less exemplary in the course of his vast theoretical work, Claude-Nicolas Ledoux, offers a more radical statement: "Destroy the thatched roofs and you will restore the confidence and the dignity of the people."⁴ So he was even less convinced that the ordinary does not need Architecture.

Both of these two statements apply to the use of material, but also address a certain practice in their contemporary environment. Alberti addressed the medieval craftsmen who knew how to work with their physical materials but did not have any idea of how their piece of work would fit into a greater whole, while Ledoux addressed the social disparity towards the end of the Ancien Regime. They were both on the edge of a shift in social organization. Alberti witnessed the shift from medieval absolute space to relative space of mercantilism and Ledoux experienced the early beginnings of industrialization and the change from feudalism to civil society. They both declared the traditional ways of building of their time and locations as being inappropriate for a newly emerging age.

But still the continuous field seems to be intriguing in terms of spatial and social cohesiveness compared to the city of modernity, oscillating between inappropriate extravagance and tedious boredom. Although Alberti might not agree that this 'beauty of the field' is really a sign of the absence of Architecture. He might answer that most buildings representing wealth, from the Venice City Dwelling over the Amsterdam Canal House to the nicely clad but cheaply made pre-modern worker's tenement of the period of promoterism were certainly designed by people who called themselves Architects⁵. And also Ledoux might answer that the continuity of the field only displays the cultural and social coherence of the people accommodated. Not only the well-functioning picturesque downtown quarter appears as a continuous field, but also the Ghetto, the Slum and the shabby shacks of peasant villages. Habraken agrees that when societies change from agricultural to industrialized, from oral to literate, environmental conditions have to adapt as well:

In Modern times, all this changed. Traditional ways of building became obsolete as new materials and new techniques emerged. Age old building technologies could no longer serve the needs of a rapidly changing society. New ways of transportation and communication disturbed familiar processes.⁶

Additionally since Modernism we face the fact that the market for Architects has switched from a seller's to a buyer's market. By rationalizing building strategies, the development of industrial production has grown from producing materials to the production of the buildings themselves. Today everyone can go to prefab house exhibitions and just shop a house of a desired type in any favored variation. Even worse: these types have been produced and improved Thousands of times by the industry. No Architect will ever be able to compete with this, as long as we try to imitate existing themes or types or act in obedience to the field. Architects get employed if no standard solution is required, but rather when creativity is desired. For this reason in architectural research, it appears to be necessary to find answers to questions the field does not ask, as long as we conceive it as an unconscious, self-reproductive mechanism. Taking a sly glance on Christopher Alexander, Alberti might state that we have been given the great gift of consciousness that enables us to reclaim mastership and to find newly appropriated solutions for the multi-ethnic yet multi-ethnic societies of the future.

1.0 THE APPROACHES

Not just since the Deleuzian distinction between roman and gothic ages, or the conflict between constructivism and structuralism, or the gap between relativity and quantum mechanics, or the imperative versus the declarative programming paradigm, or the Cartesian versus the Riemannian Spaces, has there been a notion of two sometimes opposed, sometimes complementary approaches to the way objects in space and their relations towards each other can be conceived. The above mentioned protagonists also were chosen, because they exemplify these approaches in the field of spatial organization.

1.1. The atomistic approach

The great achievement of Alberti was precisely to open up space, by clearing the field. With a huge effort he studied the field and literally 'pointed' out the remarkable and swept away the in-between. Figure 1 is a self-programmed adaption of the famous Albertian 'Map of Rome', using the parameters as published by Mario Carpo and Francesco Furlan⁷ in their favorable explanatory book "The Delineation Of The City Of Rome". The tables Alberti provides are classified in categories, such as 'Walls', 'River', 'Sites', characters, such as 'corner', 'apex', 'icon' and a context in which they appear. The buttons marked by rectangles trigger self-organizing maps to draw the lines in the way Alberti advised us to⁸. For the present paper it is important to note that with Alberti we are in space. His 'Six Elements'⁹ and his proportionate 'Lineamenta' establish parametric relations in space. By reducing the continuous field to discrete objects, Alberti delivers the ground on which the new Rome of the Renaissance could be built.

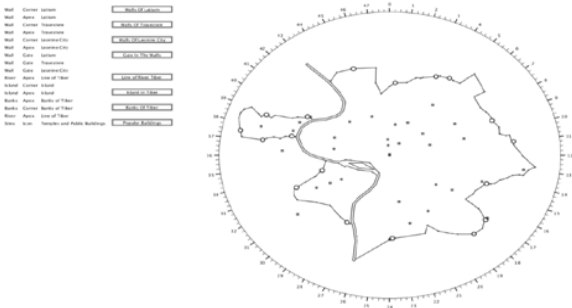

Figure 1: Parametric map of Rome as described by Alberti.

Alberti exemplifies the ‘Atomistic Approach’: There are discrete Elements, whatever they are, and we can relate them. His stance towards the field was not to improve by continuation, but rather to not contradict the forces beyond control.

1.2. The axiomatic approach

Taking a leap from early Renaissance to late Enlightenment, Alberti’s counterpart was Claude-Nicolas Ledoux, who will be considered to exemplify the ‘Axiomatic Approach’: Everything is related, but subjected to a unifying grammar, which continuously transforms one instance into another. So with Ledoux and the grammar we are in time: Out of the atomistic structures in space comes a continuous stream of algebraic information processing. And with time the grammar introduces the system.

1.3. Making instances of types

If we wish to explore the possibilities of a system, transformation is being introduced, and so are the rules of transformation. These will be arbitrary in the beginning and then appropriated through the course of the possible transformations. This can be exemplified by the rough implementation derived from the transformation grammar of Ledoux for his ‘Propylées de Paris’ as shown in Figure 2. Although this is completely liberated from any content and only based on geometrical bodies it gives an idea, how continuous transformation can also work on discrete objects: There is a certain spatial structure of hierarchical order, axiomatically reaching down from a dominant spatial element to others being constrained to it. By shifting the dominance from one type to another, the elements out of which these are built will change in size and nature. The constrained parts do not automatically flip along with the superior part they are attached to, as long as their own appearance does not contradict the appearance of the superior element.

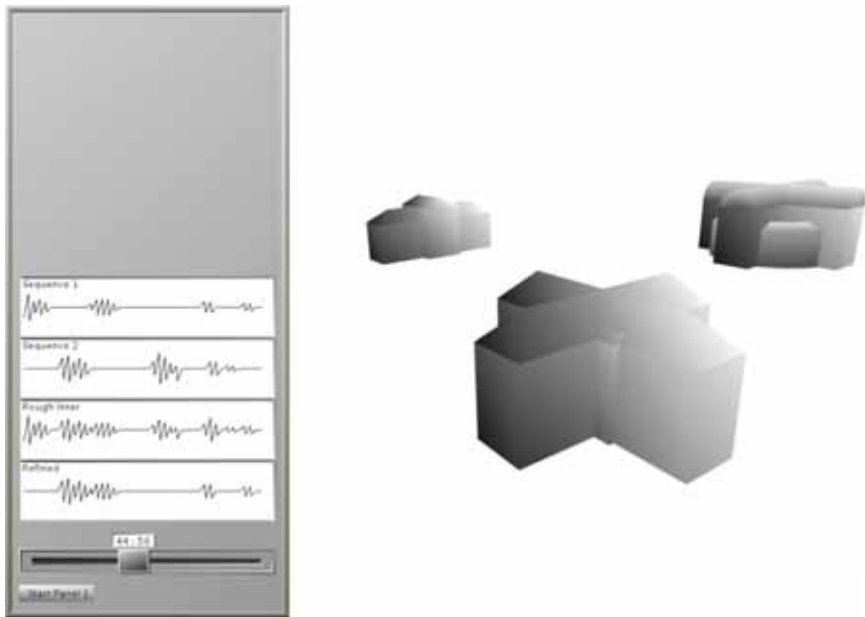

Figure 2

language¹⁰. By this, a huge number of in-betweeners can easily be created from only a few distinct types: The Grammar fills the space of possibilities.

And this can be laden with complexity, until the program would be able to create the Renaissance Palace or a Chicago-Style High-Rise and everything in between and no Architect will be needed anymore, hence this is an active code in the sense of Bruno Latour as he states it in “On Recalling ANT”. There is no creativity in designing in-betweeners or even in re-creating types, as long as they are subjected to a system. This is just mechanistic agency. So, an act of creativity would be to break the rules and to challenge the system. Computation can provide the opportunity to do this experimentally without doing harm to an actual environment.

2.0 THE PRE-SPECIFIC

2.1. About program

A “hotel”, a “shopping mall”, or a “school” give us specific ‘programs’. That does not necessarily mean that they need specific forms to inhabit. The idea that program makes form is a vestige of the functionalist approach of Modernism. The designers who could creatively fit the program for a hotel in the block formed by historic houses might equally well have done a school, a shopping mall, or the headquarters of a corporation, using the same buildings. Human activities make human beings inhabit human size spaces. The space behind two windows of a canal house can accommodate ten or twelve persons meeting, four or five persons working, a spacious private office; a hotel room for two.¹¹

In this quote N. John Habraken gives us an idea of how a whole range of requirements can be accommodated by a single appropriate form. The difference between programs is not settled in the spaces themselves, but in the way these spaces are linked towards each other: Does a private space allow slipping in and out unseen? Does an office connect to other offices occupied by working groups concerned about similar issues? Is a reception room accessible without disturbance of everyday business? So ‘program’ is more of a question of accessibility than of form. According to this Habraken states on page eight of the same article: “Programs do not make such order, they inhabit it.” And this also shows the inappropriateness of the functionalist approach. As he points out in “Type As A Social Agreement” the Qa’a houses of the Arabian medina have a very specific spatial organization according to the traditional socio-cultural organization of the people inhabiting these places. This specific configuration serves a specific functional approach that has been appropriated over centuries. But this function will collapse if social circumstances change. On the other hand, by exemplifying the Amsterdam Canal Houses or the Parisian Hotel, it becomes obvious that the functionality of spaces can change along with demands. So what does this tell us? Every utilization of a spatial configuration imposes a system, but this system is not a spatial one, it is a system derived from the activities taking place. And so, far too often, place and space are being mistaken. In this perspective a place is an appropriated space, bound by constraints to other places within a spatial structure and by this ‘placed’ or located relationally.

The term ‘structure’ is here used on purpose: Among the aforementioned examples, the structure remains similar: the public space outside enters into a larger place, which is the ‘Diwan’ in the Qa’a, the ‘Hall’ in the Canal House or the ‘Grande Sallon’ in the Hotel, which then distributes into smaller, increasingly private places. But is this a system? As pointed out, a system involves time and alters a given input information into a processed data output. This does not apply to space: The Diwan is an everyday common room, accessible only to the men of a patriarchic social system. The Hall of the Canal House is a transitional space for receiving guests and immediately taking them somewhere else, but representing the wealth of the owner in a mercantilist society, while the Grande Sallon of the Hotel, certainly has the same representational purposes, but has been the location of extravagant gala evenings in feudalist society. So a spatial structure can host very different processes of different socio-cultural systems.

If speaking of grammars, the idea of meaning in a language will quickly arise. Ledoux for example tried to establish a semiotics of space, by implementing spatial figures. The cube, he argued, was the sign for justice:

[...] the shape of the cube is the symbol of justice, it is to be placed on a square base, from where it will punish the tort and reward the virtues.¹²

He applied the cube for his designing of courts and at least from the point of view of the Third Estate towards the end of the Ancien Regime this was a ridiculous misconception. And at the latest when he built the 'Propylées' his effort in supporting and improving the social system by manifesting it in a 'spatial system' ended up contradicting his own intentions.

So even in grammar it seems possible to go beyond the axiomatic hierarchical notion of the Chomsky-Grammar, by referring to the Danish linguist Louis Hjelmslev¹³ who stated that form and content are in arbitrary but appropriate relation. We can provide spatial structures, where the activities of the people who make up the inhabiting systems can take place and yet avoid the conflicts we produce if we try to impose our own reductive understanding of a particular system.

2.2. In the field

The examples given by Habraken are well chosen, as they show the genericness behind the given specific types. So it appears to be appropriate to create spatial organization¹⁴ as generic as possible and yet render it into the typicality the people we wish to accommodate are familiar with: preserve the richness of possibilities by simultaneously seeing that socio-cultural systems are changing, utilization is changing, demands are changing through the challenges of high fluctuation, multi-ethnic environments and the changing life-plans in modern, yet contemporary, society.

All systems, even the very high-tech one's, develop, change, and bloom through use. To learn about them we should connect to the group that applies them. Books will only tell us what is no longer in discussion. The fully documented system is a dead system. [...]

Partly to cope with this dynamic variety we have learned to use systemic abstractions speaking more generally, for instance, of building morphology or spatial orders, translating them later into specific materials and products¹⁵.

Another way to put this is: if we speak of systems in space, we speak of pre-specific systems, which will be specified by their particular utilization, typified by particular application of materials and construction methods. Sometimes a stylistic application of geometrical forms is just glued on the structure's skin which is unfortunately mistaken for 'Architecture'.

But this also raises the question whether a particular spatial structure that can be inhabited by different programs might not also represent several fields at the same time. This is the moment where the approach of 'active space' comes into play. Which means: a spatial structure allows for patterns of activities, without determining what these activities will be, unless a program is formulated. So the program becomes an individual within the generic.

2.3. On the economy of systems

According to the three aforementioned protagonists there are also three approaches towards dealing with the process of building. Alberti's atomistic approach does not actually involve a system:

But herein, I repeat my Advice, let your Moderator be the Prudence and Counsel of the most experienced Judges, whose Approbation is founded upon Knowledge and Sincerity: Because by their Skill and Directions you will be much more likely, than by your own private Will and Opinion, to attain to Perfection or Something very near it.¹⁶

For him the Architect is one among many skilled professionals, although responsible for the coordination of the building process. For Ledoux and his axiomatic view, the Architect is the one and only responsible central person in charge:

It is the architect who must keep an overview; he can exhaust the possibilities of the industry, he can economize the products, he can avoid costly repairs, he can propagate the funds his art makes available for him in abundance.¹⁷

Habraken again has a rather technical perspective where the systematics of building itself is put into the centre

Today's pluriform environment does not allow a single product like a brick to support all communication in the field. The building is now a composition of systems, each with their own modular principles. Different buildings may contain different systems and materials.¹⁸

With the help of grids, traffic of parts in space can be organized. In fact, for a single project, more than one grid may be used. Starting from a basic grid, other grids, serving their own systems, may have modules derived from the base grid module by multiplication or subdivision. Interrelated grids may operate on different levels of intervention.¹⁹

This is due to the increased complexity of contemporary building projects. Nowadays many Architects are usually involved in a single project. But this also raises the necessity for a new way of organization. Like Alberti Habraken centers his approach towards organization of objects in space.

Taking this one step ahead would mean an inversion of this notion, like Ledoux²⁰ did compared to Alberti: not to organize objects in space but the spaces themselves. But unlike the baroque conception of adding, subtracting and crosscutting units of space, we are now, as with Habraken, operating on different levels of space; on superimposed programmatic fields. The relations between these fields have to determine how these different layers 'deal' with each other. This is why a conception of active space might rather be called an economy than a system. Several systems, or axioms, of equal value deal with each other, instead of ordering them into grids, which will be determined by a unified common denominator.

This is why Riemannian spaces are so interesting. There is not one function governing one specific figure, subsuming it under the smallest common denominator, but local curvatures of space itself that rule over one part of it, contracting it to all the other parts. The link between them is the Cipher, the 'nothing', which contains the code of computing how the systems cope with each other. Coding opposed to formulation is what makes computation different from calculation. Coding is a creative process and not an act of agency. Another, not too literal, analogy to the Riemannian approach to geometry would be this: instead of defining a non-Euclidean form through $n+1$ Dimensions, which means nothing but to define a non-Euclidean form yet by means of Euclidean space, we operate with $n-1$ modes of variability and we do not include a single form into a Newtonian Container Space of reference, but the spaces are made up out of themselves by their locales. The so derived structures could then be rendered into a contextual space of a given environment.

The same should hold true for the territories of human groups. Although we are able to sense each other the shopper at daytime will not be disturbed by the party-people of the night. Instead of thinking positively: this is a zone for working, this is a zone for residential purposes, this is a zone for etc. it could be possible to avoid contradiction between differentiated utilizations.

One approach to render connectivity and non-connectivity into space could be the following one: Stating there should not be a single function governing a spatial figure, but rather an equational approach of local operations. Space is used as an active element of computation. Quantized bits of space then have to cope with each other by a grammar, contracting the ways how they impact on each other.

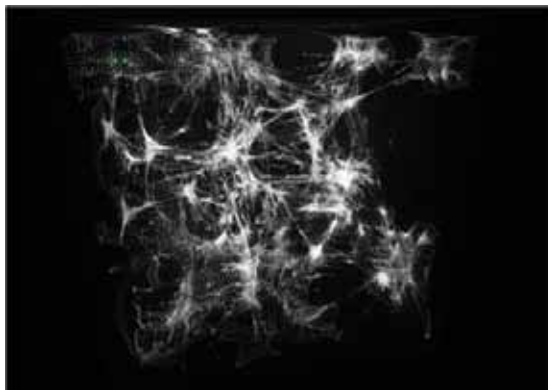

Figure 3

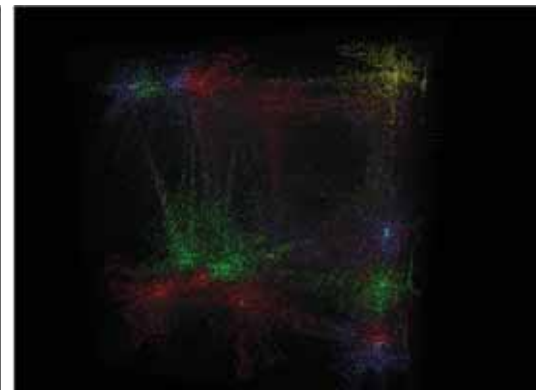

Figure 4

By this, space becomes a morphogenetic topology, as it would be called in geometry optimization²¹. Only in this case we are not talking about material objects in space but about how systems included in space inhabit and transform its structure. Figure 3 shows how agents induce their properties on such spatial quants. These were named 'Spaxels', as they like Voxels, have got spatial dimensions, but they can take attributes and values of the agents embedded and through this bridge the connections between them. As shown in the figure, these connections make up joints, where no object (agent) has been before, widen up to shady volumetric figures and shape the spaces in between. Taking it a step further, it can also be shown how different fields can be promoted simultaneously. In Figure 4 it can be seen how some fields do connect and others do not, e.g. the ones represented as red and green. This tool can now be equipped with the data from an actual environment or even better with a continuous stream of data taken from the movements and gatherings of actual groups of people. The volumetric figures represent the localizations of as yet undetermined activities, but may exemplify those solutions already incorporated in the 'ordinary', the everyday life of the people we build for.

CONCLUSION

To summarize the above mentioned strategies, there are four major issues to rely on:

1 - The Atomistic Approach. There are computational tools such as the self-organizing map, which do not represent a hierarchy. They just order Elements of equal value, reduced to numerical data and liberated from all possible content.

2 - The Axiomatic Approach: The field, as N.J. Habraken defines it, is constituted by grammar. A grammar consists of infinite vocabulary, finite alphabet and a specific set of rules. The grammar fills the space. It is implicitly contained in any field and needs to be explicated.

3 - Rather than finding the positive rules for the few things allowed, Christopher Alexander gives us a great approach to figure out the negative rules, for the things to avoid. No matter how extensive a set of these negative rules will be, the possibilities remaining are still vast compared to the few possibilities offered by a finite set of positive laws.

4 - Computational programs can only be disparate and reductive, because anything else would mean they become tyrannical: All we do in scripting is to define selective modes, chosen from everything there is, for a specific reason: we may never mistake the tool with the ruler.

The Spaxels as a species of quantized active space opens up the potentiality to embed objects in space, which are distinct and unconnected but yet able to react on each other by analyzing the potential drop of properties in their locale.

Ongoing experiments with this tool could help to represent more in space than just geometries, but to render back information topologies into geometrical figures. Ending this paper, there is one more term to introduce: Modernism and Functionalism have been about reason and mechanisms. Like the last great axiom trying to explain the universe "E=mc²", this involves judgment on cause and effect. But Architecture has arrived in the digital age, which is not about judgment but it is about appropriation and making sense out of information. In a quantized environment axioms become elements themselves, dealing with each on equal ground. Each one is special and that is normality. Philippe Morel recently brought about the term 'Quantum Architecture'²². Not comparing this adjacent approach to the sophistication of his work, but quoting him by permission as a source of inspiration. This is why the Spaxels introduced in this paper are considered to be a new approach to space: what they do is negotiate information bit by bit, not imposing an axiomatic function, but superimposing fields for activities.

ACKNOWLEDGMENTS

Kind regards and many thanks to all the people at the chair CAAD of ETH Zürich for admitting me, Especially to Prof. Dr. Ludger Hovestadt, for his influences, as well as Dr. Vera Bühlmann and to Mathias Bernhard for providing parts of the code for the 'Map Of Rome'.

Kind regards to my supervisor Prof. Dr. Karl Schwalbenhofer at BU Wuppertal and to Franz Heiner Verhaeg for giving me advice in programming.

And not to forget: thanks a lot to Dan MacGregor for doing some significant revisions.

REFERENCES

- Leon Battista Alberti, 1755. *Ten Books On Architecture*, trans. Edward Owen, London, accessed Dec. 2014:
http://archimedes.mpiwgberlin.mpg.de/docuserver/images/archimedes/alber_archi_003_en_1785/downloads/alber_archi_003_en_1785.text.pdf
- Mario Carpo and Francesco Furlan, 2007. *The Delineation Of The City Of Rome* Tempe, Arizona, ACMRS.
- N. John Habraken, *Type As A Social Agreement*, 1 (Seoul, 1988), accessed Dec. 2014,
http://www.habraken.org/html/downloads/type_as_a_social_agreement.pdf
- N. John Habraken, *Tools Of The Trade; Thematic Aspects of Designing*, (1996), accessed Dec. 2014,
http://www.habraken.org/html/downloads/tools_of_the_trade_final.pdf
- N. John Habraken, *Questions That Will Not Go Away: Some Remarks on Long-Term Trends in Architecture and their Impact on Architectural Education*, (2006), accessed Dec.2014,
http://www.habraken.org/html/downloads/questions_that_wont_go_away.pdf
- Louis Hjelmslev, 1953. *Prolegomena to a Theory of Language*, (Baltimore, Waverly Press)
- Bruno Latour, 2006. "Über den Rückruf der ANT," In *ANThology: Ein einführendes Handbuch zur Akteur-Netzwerk-Theorie*, edited by, Andrea Belliger and David J. Krieger, Bielefeld, Transcript
- Claude-Nicholas Ledoux, 1981. *L'Architecture considérée sous le rapport de l'art, des moeurs et de la législation*, Nördlingen, Uhl.
- George Stiny, *Shape: Talking about Seeing and Doing*, (2006), accessed Feb. 2015,
<http://shapetalkingaboutseeinganddoing.org/Shape.pdf>

ENDNOTES

¹ A/N: Reading the books of Alberti one will quickly realize, that there is only one passage in over 700 pages, where Alberti states, the Architect should accept advice from the skilled craftsman, as he best knows the materials he is working with. But there are vast parts in the Ten Books, in which Alberti very precisely describes, how the different materials were produced, how they should be applied, what granulation of sand for which purpose of what kind of mortar. Or: how the abutments should be placed on the bearings to prevent flashover. His Ten Books are not a manifesto to distinguish the Architect from the craftsman, but rather a tutorial on how a good building should be planned *and* crafted.

² Leon Battista Alberti, 1755, 357

³ Leon Battista Alberti, 1755, 562

⁴ C.-N. Ledoux, 1981, 103

⁵ An analogy to this would be the development in China during the recent years. My fellow Wu Jiaji, who was working in Philip Johnson ° Alan Ritchie's office in Shanghai the time I visited in 2006, could not understand my pity in tearing down 'these shabby old Hutongs' and replacing them with comfortable high-rise residential buildings. Our own view on our past in Europe is also quite romanticizing since we forgot about the terrible conditions in these 'wonderful' traditional housings in Europe, which are nowadays equipped with toilets and bathrooms and still seem full if they are inhabited by around one-fifth of the people they were actually built for.

⁶ N. J. Habraken, 2006, 2

⁷ Mario Carpo, Francesco Furlan, 2007

⁸ In fact the "Apexes" are drawn as "Corners" – for the sake of brevity.

⁹ regio, area, partes, partibus, tectum, apertio

¹⁰ 'Language' in the sense of George Stiny, which defines language as system.

¹¹ N. J. Habraken, 1996, 7

¹² C.-N. Ledoux, 1981, 115

¹³ Louis Hjelmslev, Prolegomena to a Theory of Language, 1961,

¹⁴ I do hesitate to use the term "spatial order" as 'the order' is necessarily top-down commandment, while 'organization' is unfortunately connoted by a functionalist point of view, but at least neutral in the sense of how it is achieved.

¹⁵ N.J. Habraken, 1996, 12

¹⁶ Leon Battista Alberti, 1755, 94

¹⁷ C.-N. Ledoux, L'Architecture, 1981, 122

¹⁸ N.J. Habraken, 1996, 34

¹⁹ N.J. Habraken, 1996, 35

²⁰ Although it has to be added that the baroque void certainly appeared long before Ledoux.

²¹ With kind regards to Asbjorn Sondergaard and his remarkable work topology in digital fabrication.

²² With kind regards to Phillipe Morel and his inspiring talk he gave at our chair during the time this paper was written.

Building without nails: Enabling flexibility and structural integrity through digital prototyping

Basem EID Mohamed¹, Frederic Gemme², Aaron Sprecher³

¹McGill University School of Architecture, Montreal, Quebec

²BONE Structure® | Simple Concept, Laval, Quebec

³McGill University School of Architecture, Montreal, Quebec

ABSTRACT: The convergence of digital tools, materials, and production processes has offered designers the opportunity to respond to diverse forms of users' demands for design variations, in an efficient and precise model. Different methodologies have been proposed with the aim of efficiently accommodating flexibility in the building realm, based on technological applications. This paper demonstrates recent developments in combining advanced structural design with computational modeling, towards realizing a construction system that allows for significant flexibility and adaptability in housing design within the Canadian context. Based on advanced Digital Prototyping strategies, the system enables high accuracy in the design phase leading to subsequent precision in production and assembly. Such an application allows delivering high levels of detailing in production of structural components, thus supporting the intention of pre-defined assembly on jobsites and reducing waste. The paper represents a phase from an ongoing research endeavor that aims at enabling customization in housing realm, based on digitization of the design and production processes.

KEYWORDS: Flexibility, Adaptability, Customization, Prefabrication, Digital Prototyping.

INTRODUCTION

Recent developments in digital design tools and techniques have offered the Architecture, Engineering, and Construction (AEC) industry the means to allow for higher control over the design, manufacturing, and construction processes. Through the use of advanced design and modeling software, designers and engineers are developing abilities to simulate structural performance, components production and assembly, towards a more efficient, and precise model for construction. While these technologies allow for cost and time control throughout various processes, one of the key factors is supporting the notion of flexibility. The term flexibility comprises multiple principles within the domain of architecture, including modularity, adaptability, and renovation (Till and Schneider 2005, 287). These concepts have been an interesting area of research and exploration, with the aim of developing strategies to design building components that would adapt or modify itself to changes. Commonly, buildings are aimed to change in response to social, economic, or environmental aspects. However, one of the main limitations of implementing flexibility is high cost, and complexity associated with linking design to construction components.

Pertaining to housing, Till and Schneider (2005) defined flexible housing as buildings that can adapt to the changing needs of occupants, comprising different possibilities of pre-construction layout selection, as well as the ability to change one's housing over time. Additionally, it includes the capability of integrating technology throughout occupation in response to change in demographics, or adaptive re-use. As a result of wide modes of applicability, there are numerous approaches for achieving flexibility.

Within the context of this research, flexibility is explored on two levels. The first level examines flexibility at initial design stages, with the notion of enabling participatory design in the form of pre-construction choices to homebuyers. The second level is denoted with post-occupancy adaptability, with the aim of responding to prospective changes in socio-demographic characteristics of occupants. The framework for this approach stems from the structural system and its design model, coupled with Digital Prototyping strategies. On the one hand, the physical characteristics of the system's components and their configuration establish the basis to analyze the capacity of housing designs to accommodate variations requested by homebuyers. On the other hand, Digital Prototyping empowers high precision in visualization, fabrication, and assembly of building components, thus enabling implementation of design variations efficiently. The aim of such a framework is to respond more effectively to wider sector of customers and market demands, given the variation in socio-demographic patterns, thus expand market shares.

1.0 DESIGN FOR FLEXIBILITY

Design for flexibility involves a certain logic of technological applications with regard to the provision of services that allow for various configuration of components. Such a logic is based on a clear differentiation between elements that are fixed, and others that are open to change and variation. Perhaps one of the

leading constructional principles to facilitate flexibility in housing is “supports”, developed by Habraken in the 1960s, for the Dutch housing sector. This theory presented a vision of housing wherein a dwelling would utilize a process that supports and adapts to user decisions within a larger framework of communal services and infrastructure. The theory distinguished between two fundamental components: “supports” and “in-fills”. While “supports” are regarded as the physical entity, or the rigid part of the building, “in-fills” represent the flexible part that could be adjusted on different levels: social, industrial, economic and organizational. The system was designed to facilitate variations of floor layouts over time, while also accommodating the design of dwellings to meet the diverse standards of normally accepted housing in any particular society (Habraken 1972). This foundation further developed and promoted Habraken’s open building method, and thus marked the first attempt towards personalization on a mass scale in the Netherlands (Habraken et al. 1976, 81).

Following these efforts, Kendell and Teicher (2000) have subsequently explored various trends towards open buildings. They have also proposed flexible and economical methods for implementing these systems in levels, based on analysis of realized projects around the globe. Both Habraken, and Open Building approach focus on the application of technology, modern construction techniques, and prefabricated components as viable strategy to enable flexibility.

The system described in this paper combines innovative structural design, with digital capabilities in order to achieve design flexibility on two levels: macro and micro. Whilst macro flexibility is denoted with volume and exterior perimeter of the building, micro flexibility describes variations that can be implemented within interior blocks, without affecting building envelope. Such an approach to flexibility bases its logic on the concept of modularity, and standardization of components, leading to multiple configuration possibilities. Modularization of design supports multiple product configuration by simultaneously taking advantage of the economies of scale and scope. This enables accommodating design variations on various levels. Additionally, the application of digital design strategies, considered as a vital technological enablers of the model, allows for high precision in fabrication and assembly through data management, as well as comprehensive documentation of building information.

1.1. Enabling customization through flexibility in design

As mentioned earlier, one of the main concepts of flexibility in design relates to allowing user participation at early design stages. Such a concept has become a viable approach in response to sharp increase in demand for personalized goods and products, thus defying standard mass production paradigm; one introduced by Ford in 1920s. Later on, in the 1960s, the integration of information technologies, and digitization of design and production processes lead to a new paradigm. Toffler’s 1970 book “Future Shock” anticipated these changes as technological capacities, and he further described them as a “third wave” in a subsequent study (Toffler 1980, 72). Also referred to as mass customization by Stanley Davis in his 1987 book “Future Perfect”, this process was formally systematized by Joseph Pine in 1993.

Many segments of diverse and variable industries are currently moving towards greater customization in reaction to consumers and markets demand. Within the building industry, components could be mass customized, allowing for optimal variances with regards to differing contextual characteristics, therefore enabling the production of uniquely shaped and sized buildings. Ever a vital sector in the building industry, housing has witnessed a renewed surge of interest in the last two decades, especially following these new approaches to modes of design and production. Although this interest has taken many forms and constituencies, digital design and manufacturing strategies have inspired the most diverse research and pragmatic solutions to contemporary industry challenges, resulting in advanced customization solutions.

Flexibility in design can be regarded as a core component in achieving customization, whereas the level of customization relies primarily on the degree of flexibility and its relevance to the building system’s technological capabilities. In that sense, the question of this research becomes what are the dimensions of achieving flexibility. Friedman (2011) proposed a project-based decision-making model that would assist designers and builders to define the degree of flexibility in housing design with regard to project type. This is aimed at providing guidelines for the selection and implementation of resilient design strategies, so as to fit their users’ needs and maintain their market approach. Accordingly, the type of flexibility selected is based on the definition of the socio-economic backgrounds of users, in addition to cost, regulations, and execution time.

The focus of this research goes beyond traditional flexibility models, to one that stems solely from a progressive technological approach, leading to efficiently enabling customization in the housing realm. The proposed integrates the structural logic, with Digital Prototyping strategies as a vital element within the flexibility model. Nevertheless, the criteria to identify levels of flexibility and design alternatives to be offered, includes the notion of establishing a comprehensive process for making choices from a range of flexible alternatives.

2.0 THE STRUCTURAL SYSTEM: BONE Structure®

The BONE Structure® is a proprietary construction system that combines cold-formed steel components and insulating materials in an integrated manner. The steel components are all designed to be assembled using solely screws and bolts, eliminating the need for cutting, piercing and welding on jobsite. As a consequence, the amount of residual matter resulting from the construction process is reduced significantly. The system differentiates itself from traditional steel construction system by combining the advantages of a post-and-beam structure; larger spans, size of openings, the integration of the structural system with the thermal envelope, and the precision of assembly provided by pre-manufactured components.

Pertaining to form, The BONE Structure is an orthogonal system that has been designed using a 5 feet incremental module in the X-Y plane and 6 inches module in the Z direction, leading high level of standardization of components. Given that the system is always undergoing research and development, the latest version of the system (10.0) includes the half-grid feature, providing more flexibility to the architectural design.

The various structural components are fabricated using typical sheet metal processes and equipment, including Computer Numerical Control (CNC) punch presses, laser cutting, bending and stamping. Additionally, robotized welding is used for some assemblies. All components have an overall length of maximum ten feet in order to facilitate procurement. Structural columns have a composite square profile, 4 inches x 4 inches, assembled in plant employing self-tapping screws. An additional H-shaped profile can be added on the exterior side of columns to enhance their resistance to lateral loads. Stronger members are designed using a thickness of 0.1875 inch whenever required. Figure 1 represents a holistic view of the structural system components.



Figure 1: An overview of the structural system, and a close-up for the connection. Source: (Author 2014)

Floor and roof structure main components are variable lengths of a seventeen inches deep profile manufactured using eleven gauge galvanized steel, the maximum standard span being 25 feet. These profiles are characterized by large openings that are performed to remove some weight to the components and to allow for better efficiency for trades such as electricity, HVAC and plumbing. Stronger members are designed using a thickness of 0.1875 inch when required. Secondary joists are put in the transverse direction between the joists with a typical spacing of 20 inches.

Once land preparation is completed, and the foundation is poured and cured, steel components and fasteners are delivered. The prefabricated structural components are anchored to the foundation by using cast-in anchors available in three standardized dimensions. The anchors are positioned using spacing templates, eliminating the use of a measuring tape. Assembly instructions are obtained from digital models, thus capitalizing on the efficiency of building processes.

Floor structure is completed by adding a 0.75 in thick thirteen plies plywood panel over the steel components. These panels are pre-pierced and pre-cut using CNC machining centres. The assembly is performed using self-tapping screws as holes in plywood panels are aligned with holes in the steel structure underneath. The plywood panels are supported on all edges and define a structural diaphragm. On the roof, the diaphragm is achieved by a Structural Insulated Panel (SIP) fastened to the structure by screws installed from the interior side. These SIPs are composed of two layers of Oriented Strand Board (OSB) with an Expanded Polystyrene (EPS) layer in between. The typical thickness of EPS is 10.5 inches, giving an insulating rating of R-40. In some cases, additional structural components such as structural lintels above sliding doors and garage doors, overhangs, balconies, terrace structures and canopies are then added. Openings for doors and windows are pre-framed using pre-cut plywood parts with machined holes and grooves.

The subsequent steps are denoted with covering the complete wall area with 3 inches thick EPS panels. These panels are cut in three configurations to fit exactly in between the structural components. They are held in place by z shaped profiles. The whole wall is finally covered with a 2.5 inches thick layer of polyurethane sprayed foam. The depth of the z profiles is calibrated to exceed the polyurethane and receive the exterior finish. A nylon thermal break positioned between the z shaped profile and the structural columns prevents metallic continuity through the thermal shell. On the interior, wall and ceilings are covered with galvanized steel furring profiles that are clipped to the structure, making it ready for drywall installation. Exposed components such as architectural stair structure, exposed cross bracings, terrace structure and sunshades are typically installed when spray foam application is completed. The shell is then completed by installing doors and windows and sealing the perimeters of these components.

The presented structural system achieves flexibility in building design through three Dimensional modularity, in addition to specific physical characteristics of its components. This allows for numerous configuration possibilities, with the aim of responding to users' demand for internal and external design variations.

3.0. DIGITAL PROTOTYPING IN DESIGN

Within the engineering and design realm, Digital Prototyping is defined as the mean by which engineers, and designers can explore products virtually before being built. It allows for designers to validate, simulate, optimize, and visualize products data throughout the product development process within an advanced digital environment. Such a process is structured on different levels of automation, depending on the nature of the product, and operations involved in the process (Bullinger et al. 2000, 100).

Digital Prototyping combines Computer Aided Design (CAD) technologies with Virtual Reality (VR) to allow producing prototypes more efficiently, thus optimizing the product development process. One of the strategic advantages of Digital Prototyping is real-time decision making at early stages of product development. This enhances the process and makes it more efficient, leading to allowing for earlier modifications, and optimization of the prototype. Furthermore, virtual prototypes enable qualitative evaluation of product qualities, thus eliminating errors that might occur within the fabrication process.

Bullinger, Warschat, & Fischer (2000) defined a crucial component of Digital Prototyping that is the Digital Mock-Up (DMU); a purely digital test model of a technical product. Such a model enables for a current and consistent availability of multiple view of the product shape, function, and technological coherences. This constitutes the basis on which modeling and simulation performed and communicated for an improved configuration of the product. Commonly, virtual products are employed as a reference for testing the design regarding its feasibility, functionality, and efficiency prior to production of physical prototypes. This is done by building a comprehensive model that brings 3D data into a single 3D model. This is done either for exclusive products, or ones integrated within a system. In such a virtual environment, possible defects can be detected and corrected in design before building physical products. The model also enables unprecedented precision in establishing the link between design and manufacturing, thus improving productivity.

Digital Prototyping as an approach has been successfully implemented in various domains, such as aircraft construction, shipbuilding, and the automotive industry. Also, various software platforms have been employed, including for instance, *Autodesk Inventor*, *Solidworks*, and *CATIA* by *Dessault*. Nevertheless, the selection criteria of the platform relates to the capability of devising a workflow that is compatible with the nature of the product, level of technology involved, and users participating in the product development process. We present in this research a workflow model that complements the nature of the structural system, as well as the targeted flexibility model.

3.1. Achieving structural integrity through Digital Prototyping

The application of Digital Prototyping throughout BONE Structure system design process aims at implementing effective data sharing and management platform, to allow for collaboration between different team members. There is a series of operations that take place prior to aggregating information on the employed platform, *Autodesk Inventor*. These operations function either simultaneously, or consecutively, depending on the nature of data input/output.

The process is initiated on a Building Information Modeling (BIM) platform, *Autodesk Revit*, allowing for visualization, and validation of data at the conceptual design stage, as well as effective communication between design team members. The model is used also for referencing purposes, in relation to contextual data. The following step is denoted with integrated structural modelling and analysis, using a conventional structural analysis software, with focus on verifying, and optimizing structural members, connections, and assembly. This step is fed from a database of families comprising various structural system components; columns, beams, bracing, anchors, bolts, in addition to other connections, organized in a hierarchical manner.

Once realized, the BIM file is then imported to *Autodesk Inventor* for precise allocation and assembly of structural members within the design. Taking advantage of computational design capabilities of the design team, a special algorithm was designed and coded to automate this operation. Basically, the algorithm acts as placement agent that assigns structural components following a specific pattern, then generate connections. In that sense, the process is optimized with regard to time, and precision. Additionally, the algorithm performs, and simulates a number of the assembly tasks, in real-time, thus overcoming possible complexities associated with the building process. The implementation of this algorithm takes the 3D BIM model into a level of 4-Dimensional, and 5-Dimensional operations, whereas accurate quantities can be extracted from the model. Figure 2 demonstrates a completed model on *Inventor* and the level of detail obtained.

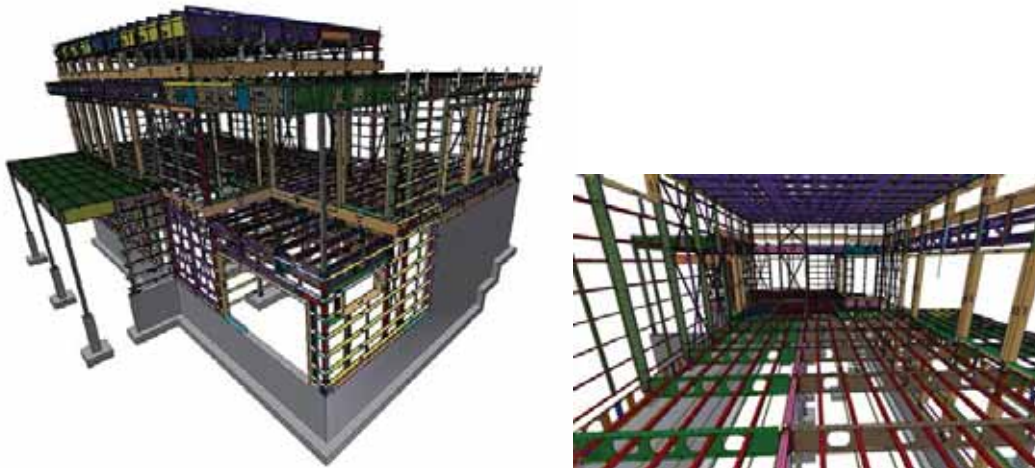

Figure 2: A screen-shot from *Autodesk Inventor* of a 3D model demonstrating levels of details in components and connections in project employing fully standardized parts. Source: (Author 2014)

In addition to just-in-time virtual tracking of components during design, the application of Digital Prototyping informs the fabrication of parts. Data extracted from the 3D model is used to feed different CNC machinery with precise fabrication instruction. Since many of the projects involves design and production of special parts, Digital Prototypes becomes a vital player in this situation. Special parts are designed, tested, optimized, simulated, and fabricated in relationship with the standardized parts. This would also lead to simplifying workflow from design to manufacturing, as collaboration occurs dynamically, thus maintaining information accuracy.

4.0. DIGITAL PROTOTYPING TOWARDS DESIGN FLEXIBILITY

The BONE Structure system is designed to enable the previously mentioned flexibility approach: macro and micro level. The key factor behind achieving these levels relies on technological enablers. While micro flexibility is intended to enable user participation in the design phase, macro flexibility explores the notion of variation in volume, and post-occupancy adaptability. Other than the innovation in the design of the structural system, Digital Prototyping is considered as a significant sub-system within the comprehensive flexibility approach. Its implementation strategy relies on two procedures: data management, and product documentation, supporting micro and macro flexibility consecutively.

Pertaining to micro flexibility, Digital Prototyping is implemented through an integrated workflow that supports editing and changing parts and components without the need to change parametric data. It allows for real-time modification in building spatial layout, while preserving the use of standard structural components. Additionally, employed to surpass conventional capabilities of the software platform, the placement algorithm and supplementary plugins operate to enhance the level of flexibility to accommodate potential design variation. In other words, flexibility in design is enabled through flexibility in the data workflow strategy. Figure 3 demonstrates possibilities for micro flexibility to support user participation.

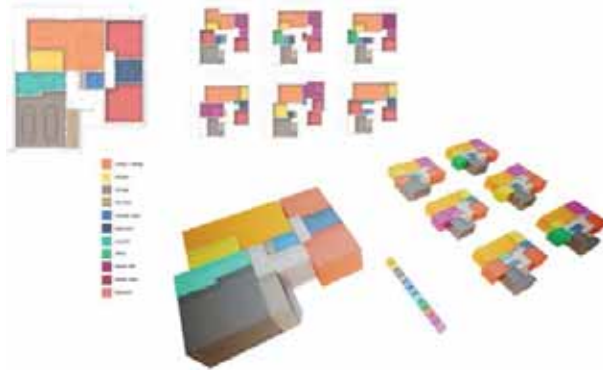

Figure 3: Micro flexibility achieved through various configuration of spatial layout functions, within a predefined volume. Source: (Author 2014)

On the other hand, macro flexibility explores variations in building volume and envelope, either at early design stages, or in the form of potential post-occupancy adaptability in response to future changes in socio-demographic characteristics of occupants. Both ideas are made possible by the structural system framework, in addition to product documentation of the Digital Prototyping strategy. Given that parts and components of the structure are assembled using bolts and fasteners, and all of these connections are documented digitally, variation in building envelope can be achieved effectually. In the case of pre-construction design, the placement algorithm tolerates configuration of special parts and components, by replacing standard ones. Yet, in other case of post-occupancy adaptability, components can be disassembled easily, then reassembled following other configuration in response to building occupants requirements. Figure 4 demonstrates a project that dictated the design and fabrication of specific parts to suite the custom design, while keeping the principles; materials, process, and standardized connection details of the BONE Structure system. Such flexibility in design, and optimization in production were only made possible through the application of Digital Prototyping, including particularly coded algorithms.

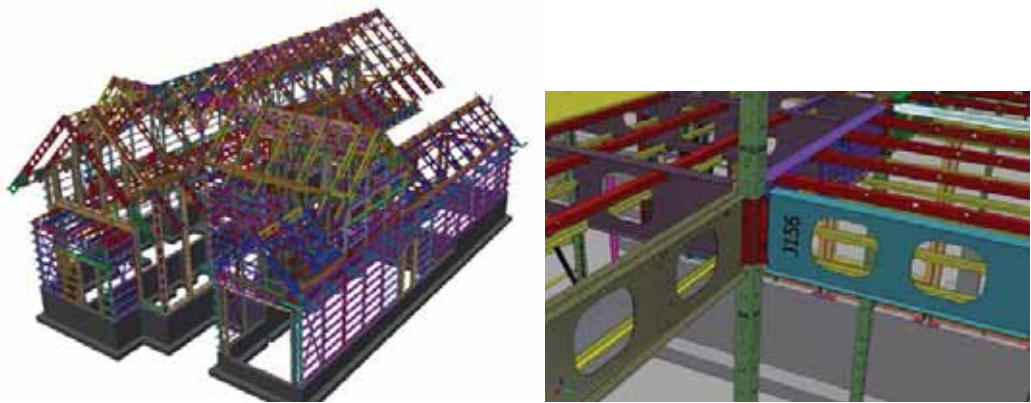

Figure 4: Screen-shot from *Autodesk Inventor* of a 3D model for a special design project. The images demonstrate level of details attained while using special components. Source: (Author 2014)

CONCLUSION

Advancements in design and fabrication technologies have changed the way buildings are being designed and conceived. Various approaches have been proposed in order to devise methodologies to model data throughout the design and production of buildings. Many of these approaches explored flexibility enabled through digital processes, referring to other engineering disciplines. The aim has been always to develop models that can consequently respond to either pre-construction variations, or adaptability denoted with changing needs over the time. These approaches have taken different forms and constituencies, with special focus on the notion of digitization of data workflows, and management.

This paper represents a technological approach to enable flexibility in the design and production of buildings, specifically housing, through combining a state-of-the-art structural system, and a digital modeling strategy; Digital Prototyping. Whereas Digital Prototyping has been applied in many engineering and design domains, yet in architecture, such an approach is still in an exploratory phase. The described Digital Prototyping platform in this paper tends to complement the tactility of the structural system, towards greater

flexibility in design. This relates directly to the concept of data management and collaborative qualities, leading to effective communication between design team members, as well as fabricators, through establishing a coherent workflow to handle design flexibility. Furthermore, to surpass conventional capabilities of the platform, a computational design logic in the form of a placement algorithm has been coded, and implemented specifically to enhance digital processes. These computational tactics capitalize on the structural integrity of the design system, through automating a set of instruction within the modeling process, thus advancing the flexibility approach.

The work described in this paper represents a phase from an ongoing endeavor towards implementing a comprehensive system for mass customization in architecture. The proposed flexibility approach, in the form of combining a structural system, and a technological strategy, is seen as a crucial element to realize the paradigm of mass customization, specifically in the housing realm. Future exploration will focus on the concept of interoperability, a more advanced form of data management.

REFERENCES

- Bullinger, H.-J., J Warschat, and D Fischer. 2000. "Rapid product development — an overview." *Computers in Industry* 42 (2-3):99-108.
- Chandra, Charu, and Ali K Kamrani. 2004. *Mass customization : a supply chain approach*. New York: Kluwer Academic/Plenum Publishers.
- Eastman, Charles M, Wiley InterScience, Rafael Sacks, and Kathleen Liston. 2008. "BIM handbook : a guide to building information modeling for owners, managers, designers, engineers, and contractors." In. Hoboken, N.J. : Wiley.
- Friedman, Avi. 2011. *Decision Making for Flexibility in Housing* Gateshead, United Kingdom: Urban international Press.
- Habraken, N. John, J. Th. Boekholt, P. J. M. Dinjens, and A. P. Thijssen. 1976. *Variations: The Systematic Design of Supports*. Cambridge, MA: Laboratory of Architecture and Planning at MIT.
- Habraken, N.John. 1972. *Supports: an alternative to mass housing* New York: Praeger Publishers.
- Kalay, Yehuda. 2004. *Architecture's New Media: Principles, Theories, and Methods of Computer-Aided Design*. Cambridge: MIT Press.
- Kanai, Satoshi, Taiga Higuchi, and Yukiaki Kikuta. 2009. "3D digital prototyping and usability enhancement of information appliances based on UsiXML." *International Journal on Interactive Design and Manufacturing (IJIDeM)* 3 (3):201-222.
- Kendall, Stephen, and Jonathan Teicher. 2000. *Residential Open Building*. London: Spon Press
- Kolarevic, Branko. 2003. *Architecture in the digital age : design and manufacturing*. New York, NY Spon Press.
- Petric, Jelena, and Tom Maver. 2003. "Digital prototyping in the architectural design studio." SIGRADI, Rosario.
- Pine, B Joseph. 1993. *Mass customization : the new frontier in business competition*. Boston, Mass. : Harvard Business School Press.
- Schneider, Tatjana, and Jeremy Till. 2005. "Flexible housing: opportunities and limits." *arq:Architectural Research Quarterly* 9 (5):157-166.
- Schodek, Daniel, Martin Bechthold, James Kimo Griggs, Kenneth Kao, and Marco Steinberg. 2005. *Digital Design and Manufacturing: CAD/CAM Applications in Architecture and Design* Hoboken, New Jersey: John Wiley & Sons.
- Till, Jeremy, and Tatjana Schneider. 2005. "Flexible housing: the means to the end." *Arq:Architectural Research Quarterly* 9 (3/4):287-296.
- Toffler, Alvin. 1970. *Future Shock*. New York: Random House.
- Toffler, Alvin. 1980. *The third wave*. New York :Morrow.
- Tseng, Mitchell M., and Frank T Piller. 2003. *The customer centric enterprise : advances in mass customization and personalization*. New York: Springer.

Computational landscape: Data driven urban modeling with agent-based system

Ming Tang¹

¹University of Cincinnati, Cincinnati, Ohio

ABSTRACT: Michael Batty described the property of “Autonomy” and “the embedding of the agent into the environment” as the two key properties of agents in an agent-based system. This paper presents the ongoing research of integrating agent-based methods with bottom-up urban modeling. The paper discusses several research projects and examines approaches where agents are set and interact with a defined environment. The research extends to the agents’ interactions driven by a set of rules and external forces. From the perspective of evaluation and optimization, a hybrid method is investigated by combining movement network, space syntax, and Geographic Information System (GIS).

The paper describes the process of bottom-up design and simulation to generate emergent urban patterns and adaptive urban forms. Starting with movement simulation, agent-based modeling tools are used to decode and recode the spatial complexity within the parametric equation. Computational tools for architects and urban designers such as a minimum path algorithm, spatial accessibility analysis, GIS, and procedural modeling are integrated to build a platform that allows parametric control of the generative outcome. The authors focus on how agent-driven emergent patterns can evolve during the simulation in response to the “hidden hand” of globalized goals. The multi-phase method starts with defining the self-organizing network, which is created by optimizing movement networks with agent-based modeling. Then, an “attraction map” is generated based on spatial accessibility and GIS data. The map is then used to control various urban morphologies and drive the construction of an adaptive urban model.

KEYWORDS: Self-Organizing, Agent-Based System, Space Syntax, Bottom-Up, Emergent

1.0 INTRODUCTION

1.1 Agent-Based System

An agent-based system (ABS) consists of numerous agents, which follow simple localized rules to interact within an environment, thereby formulating a complex system. The concept of the agent-based system has been widely used in computer science, biology and social science, such as swarm intelligence, decentralized social networks simulation, and economic growth modeling. ABS consist of interacting rule-based agents which can create real-world-like complexity. In terms of spatial modeling, agents can be defined as autonomous “physical or social” entities or objects that act independently of one another¹ (Batty 2007). Our research only discusses the agent as the physical entity within the field of architecture and urban design. It focuses on the agent’s properties and processes used to respond to external changes, specifically how the agents can “sense” and “act” to form a bottom-up system.

1.2 Agent & Environment

As the basic element in a self-organizing system, the most popular behavior of an agent is movement. The autonomous agent can represent humans, animals, robots, plants or artificial lives. “The agent-based system with motion behavior mechanisms can be influenced by the other steering behaviors, at any moment; this is, to change the agent’s location and orientation” (Baharlou, Menges 2013). The autonomous, bottom-up approach is most effective for movement-related computation. For instance, ABS has been widely used to simulate the behavior of crowds, where the agents’ movements are computed based on the interactions among themselves, as well as the interactions with the environment. Because designers are able to analyze the relationship between the environment and the agents’ movement, design decisions can therefore be made by evaluating the result generated from ABS. There were many computational methods applied to simulate agents involving movement, including “the simple statistical regression, spatial interaction theory, accessibility approach, space syntax approach and fluid-flow analysis” (Batty, 2007). Many research projects have been done to examine how agents “sense” the landscape and “walk” through it, such as the study on shopping malls and pedestrian flows by Sehnaz Genai (Genai 2008), as well as the migration pattern by Batty in the Sugarscape exploitation².

1.3 Architectural & Urban Design Application

In recent years, ABS has become an integrated analysis and evaluative process. In architecture, this process is defined as “an interaction between internal components and external” (Kwinter, 2008). Some of the emerging aspects in the practice involve utilizing ABS to generate complex self-organizing systems and geometries that respond to the interactions of elements and external forces. ABS becomes “a computational framework that incorporates its own elements, rules and interactions” (Baharlou, Menges 2013). An agent can represent various architectural entities ranging from panels, volumetric massing, egress, and even abstract building program. ABS allows complex architectural systems to emerge from simple interaction among agents. Each agent can “sense” its neighbors and “react” to them by modifying its location, shape or other attributes. For instance, Ehsan Baharlou and Achim Menges used ABS to compute the topology of a tessellation pattern across a complex surface. Li Biao used ABS to optimize the location of skyscrapers to maximize their views and solar exposure. The ABS approach can also be found in large urban design projects, such as the context-aware multi-agent system for urban infrastructure by David Gerber (Gerber 2014), and path optimization system in the Kartal Pendik urban design project by Zaha Hadid Architects.

1.4 Preliminary Research

We studied ABS through swarm intelligence, circulation movement, and network optimization. Similar as Batty’s “global attraction surface” in his study on the agent’s movement, we created an agent system to introduce “external force rules” to influence the agents’ movement behavior. (Figure 1) Similar rules were created in the layout planning researched by Hao Hua in the “floating bubbles” project (Hua, Jia. 2010). The external rules also were used to evaluate the purposive movement of agents in Clayton and Yan’s panic evacuation simulation (Clayton, Yan, 2013).

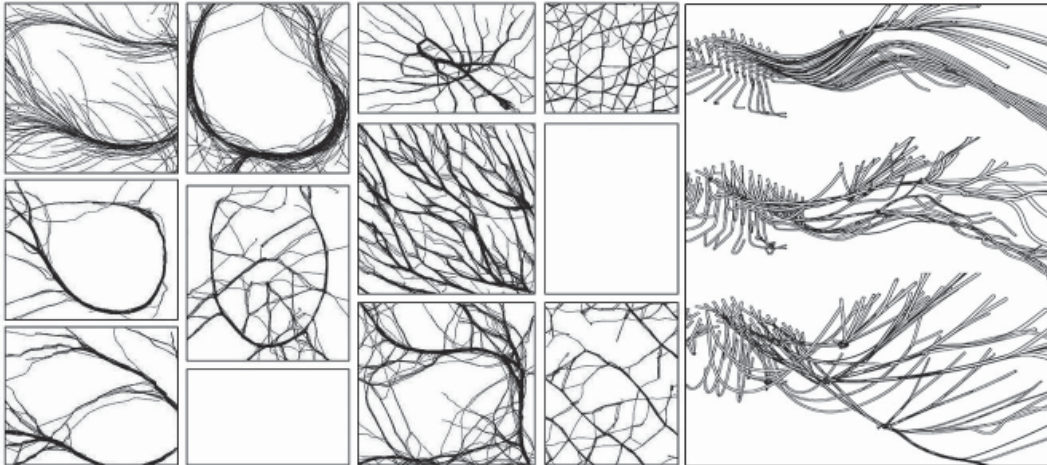

Figure 1: ABS movement network by Processing (2D space) and MEL script (3D space).

2.0 METHODOLOGY: SELF-ORGANIZING URBAN MODELING

Inspired by the parametric urbanism of Patrick Schumacher, shape grammar based procedural modeling by Pascal Mueller, self-organizing behavior research from Kokkugia, agent and cells method by Batty, as well as the wet grid by Frei Otto, we launched several preliminary research projects in 2014. The investigation focused on the movement based urban network, which is simulated through ABS, evaluated by space syntax method. (Figure 2)

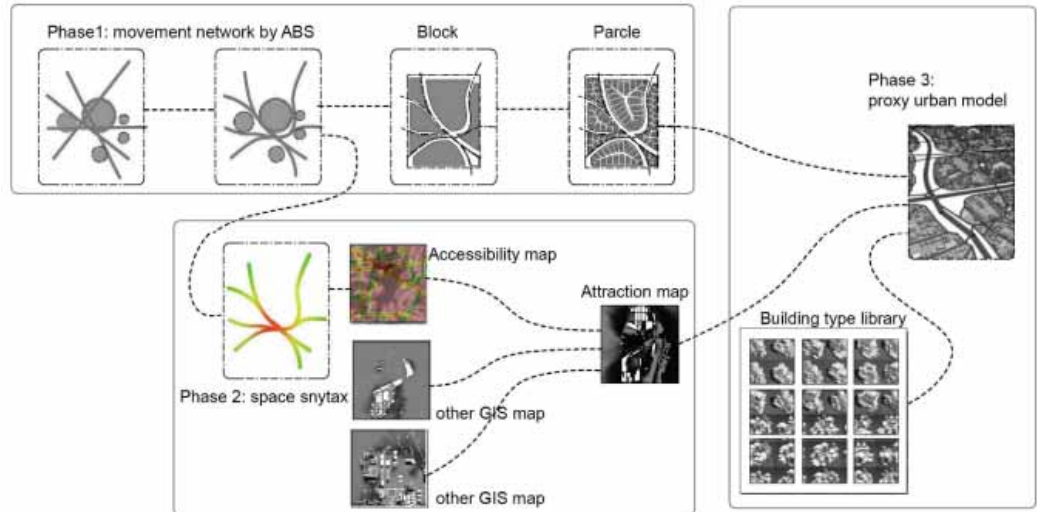

Figure 2: Three-phase process including movement network, attraction map and proxy urban model.

2.1 Phase I: Movement Network

The research began with an abstract city form by creating a movement network across a complex landscape. The goal was to form optimized paths. This approach uses a few simple behaviors of individual agents to interact with environment and other agents, which ultimately increases the complexity of the system as a whole. First, a group of agent-based spatial nodes was woven into an initial, rigid network (Figure 2). Once the two respective nodes are set to represent the start point and destination, a straight line is used to connect two nodes to represent the initial trajectory. A network optimization script is developed to generate the minimum paths using Otto's wool simulation method. Instead of a simple "dumb" static network, each agent along a path becomes an active, moving element and interacts with the neighboring agents and their trails based on rules such as proximity, attraction, alignment, and collision. The external landscape is formed by a series of contextual elements, including existing buildings, land obstacles, and non-destructive topographic boundaries. As reactive agents seek equilibrium between external forces and other agents and their trails, every agent's movement is continually modified within the micro environment by various operations such as attracting, following, repulsing, or keeping distance. The initial, rigid network thus evolves into a complex, self-organizing pattern.

With the external forces and interaction among agents, the autonomous "action" of each agent lies within modifying its own movement based on the repulsion or attraction to neighboring agents in addition to the environment itself. A complex movement organization is automatically formed over time. Visually, the agents' trails appear to be bended, deformed, and merged into one another based on their contextual relationships. Different behaviors can be assigned to form alternate emerging patterns. Designers can even set several conflicting behaviors in the ABS to allow one behavior to compete with other behaviors. (Figure 3).

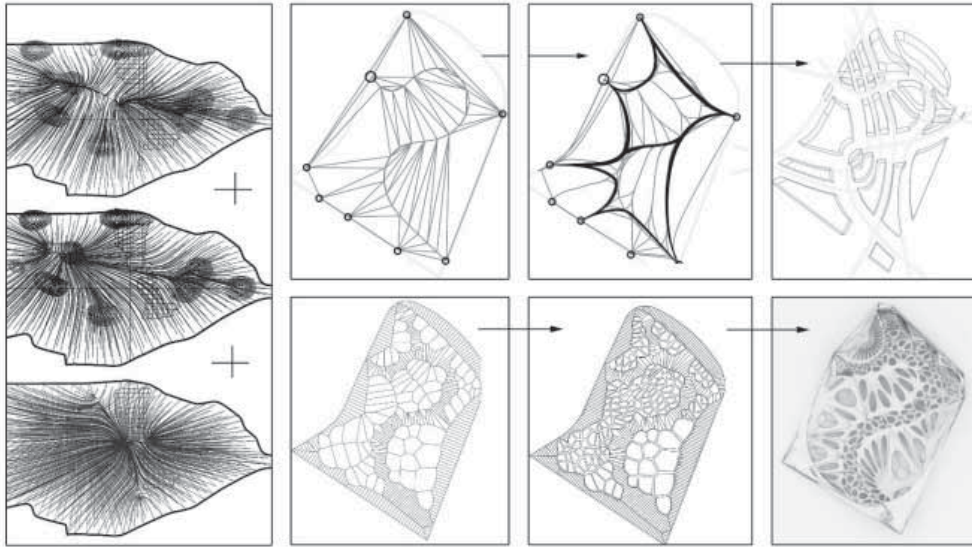

Figure 3: Phase I. A system of agents with unique values and behaviors are calculated and manipulated. The initial grid is optimized similar to Frei Otto's wet grid network³, which is a physics-based analog method. A movement network is optimized by the computer simulation based on the proximity and interaction among agents and their trails. Projects by Dallas Puckett, Derek Morphew, James DiMeolo, Yiren Weng. University of Cincinnati.

2.2 Phase II: "Attraction map" by Space Syntax

Space syntax is a powerful method to study movement patterns and accessibility of streets based on nodes and network. A street is computed as a line and open environment is computed as a cluster of "cells" in space syntax. By utilizing various spatial analysis tools, the accessibility of cells and lines can be measured. These simulated results were generated to measure spatial integration, accessibility and other circulation related values. The new data associated with the geometry can be extracted and represented as color map and data sheet. In spite of including "agent analysis" tools, space syntax does not examine the interactions between agents. However, space syntax provides a fast analysis for spatial integration and accessibility. These qualitative values extracted from space syntax analysis are then combined with other data for further computation.

Although space syntax only evaluate the relationship between "passive agents" and the environment and does not allow adding agent's behavior, we used it as a quick evaluation method to the self-organizing pattern generated in the first phase. In order to convert the space syntax data into various geometric representations, we created several data processing methods using Geography Information System (GIS) and Grasshopper scripts. The goal of this hybrid approach is to allow geometries (point, lines and shapes) to carry new data representing their spatial accessibility and spatial integration values. The values are translated into a raster image, named "attraction map"⁴ representing the overall spatial accessibility. The raster image is combined with other maps and used later in phase III to drive the urban form generation. (Figure 4)

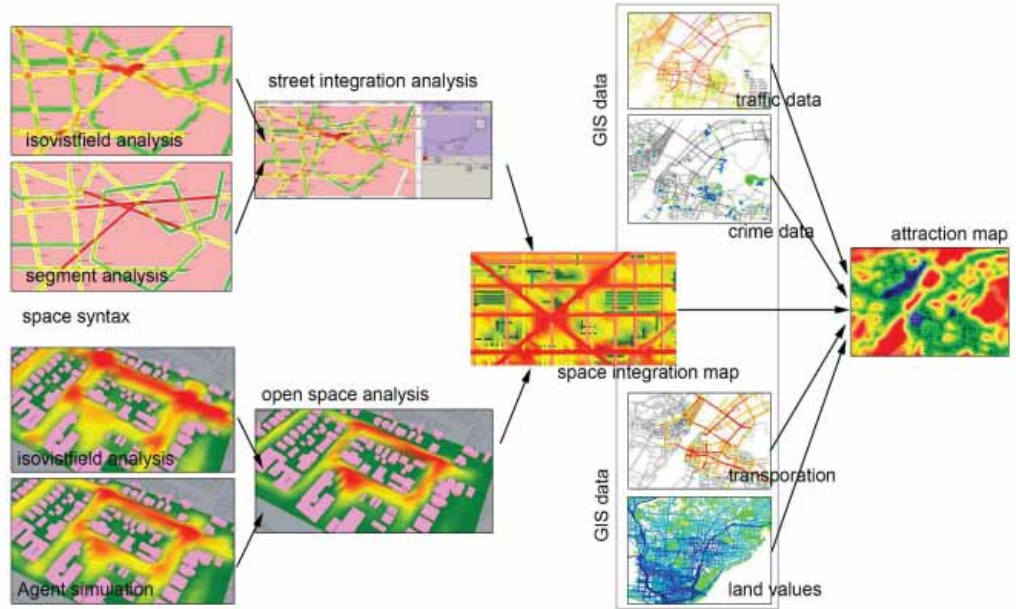

Figure 4: Phase II. The space syntax analysis is primarily used for evaluating the existing movement pattern. Then, it is combined with other GIS map to form the final “attraction map”.

2.3. Phase III, Proxy urban model

In this phase, the urban blocks are defined by the self-organizing movement pattern from Phase I. Procedural modeling techniques are used to divide blocks into parcels based on various spatial subdivision algorithm such as voronoi and shape grammar. A parcel is defined as a “place holder” with an index value projected back to the “attraction map, the “hidden hand”. Script is used to extract the “attraction” value based on the index of each parcel and populate it with appropriate buildings selected from a large building library. (Figure 5)

Besides the accessibility values from space syntax, extra GIS data were added to the “attraction map” to represent development intensity, Floor Area Ratio (FAR), zoning and other planning related quantitative attributes. These data is mixed together with appropriate weight values. Each parcel can “read” its corresponding data from the “attraction map” and then select the best-fitted building from a building library. For example, a view-shed map was created in GIS to control the building orientation. A family income map was used to control the placement of public housing. An above-60-year-old population density map was used to control the placement of senior housing. A digital elevation model (DEM) was used to highlight the unbuildable zones around steep slopes. The resulting “attraction map” guided the placement of proxy buildings, green space, parks and automatically filled parcels with 3D models. If needed, each proxy building mass can also be substituted by a highly detailed architectural unit from the building library.

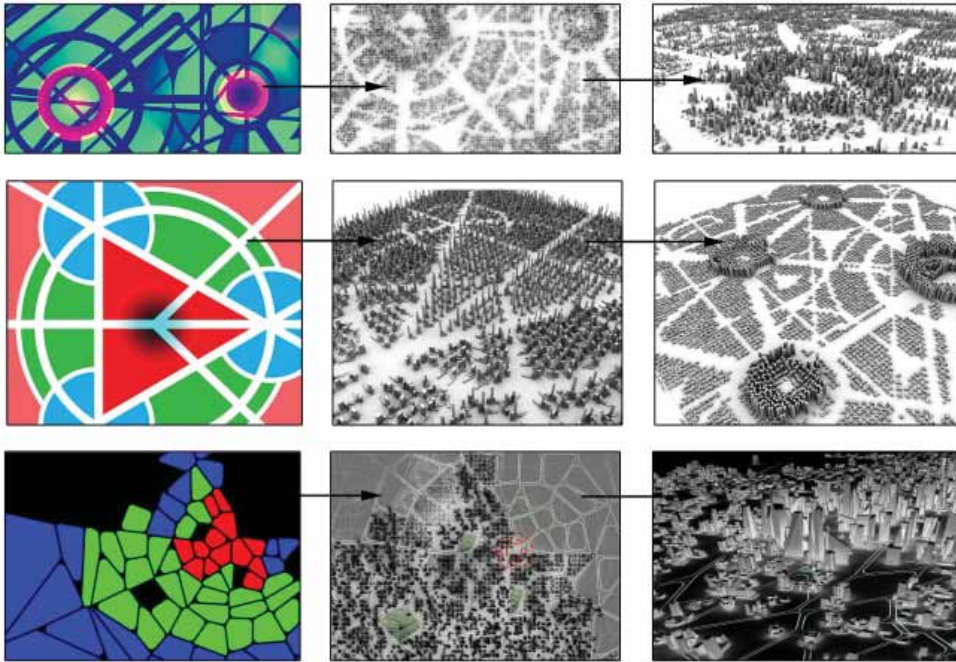

Figure 5. Phase III. Adaptive urban model constructed from “attraction map”, using script to populate various building types into the “best-fitted” parcels. Projects by Trey Meyer, Boer Deng, Guande Wu, University of Cincinnati.

3.0 PROJECTS APPLICATION

In order to test this new bottom-up approach, we applied the three-phase method to two urban design projects, sponsored by a Chinese real estate organization and a local municipal planning institute in Dalian, China. The two projects present many challenging problems for our self-organizing approach with ABS.

3.1. Silicon Valley of China

The first commissioned project is called “Silicon Valley of China”, a large urban design project in the TJW valley near Zhuhai. The project goal is to create a 6,000,000 square meter sustainable and ecological valley, which includes residential, commercial, cultural and institutional spaces. A new water system is required to improve the existing hydraulic network. We applied the movement optimization in the conceptual design stage. Space syntax was used to create an “attraction map” and combined with other GIS maps in the schematic design stage. Then, we used proxy modeling method to construct a fully detailed 3D urban model at the end. Self-organizing pattern of movement network emerged based on the external rules including the proximity to the existing urban infrastructure, slope of the topography and distance to the water body. The “soft grid” automatically adopted a set of forces that drive movement pattern with various magnitudes. A highly efficient circulation and transportation system for pedestrian, vehicle and bike was achieved by agent based simulation. As the result, neighborhoods, blocks, and parcels were automatically constructed based on the self-organizing pattern to promote the most efficient pedestrian flow and vehicular streamline.

Phase I: The self-organizing pattern was accomplished through an ABS bottom-up approach. Then, the movement network was optimized.

Phase II: space syntax was used to analyse movement network and generated an “attraction map”. Two historic villages and the proposed public space are evaluated based on the spatial integration and accessibility values.

Phase III: Proxy urban modelling based on “attraction map”. Green corridor, central park, and riverside park system were added into the 2D parcel system. 3D buildings were automatically loaded from a building library and adapted to each parcel based on the “attraction map”. The map combined various data such as the proximity to the urban infrastructure, proposed zoning and development intensity. After the automatic modelling process was completed, the skyline along the river and east-west axis were evaluated and modified by designers. (Figure 6)

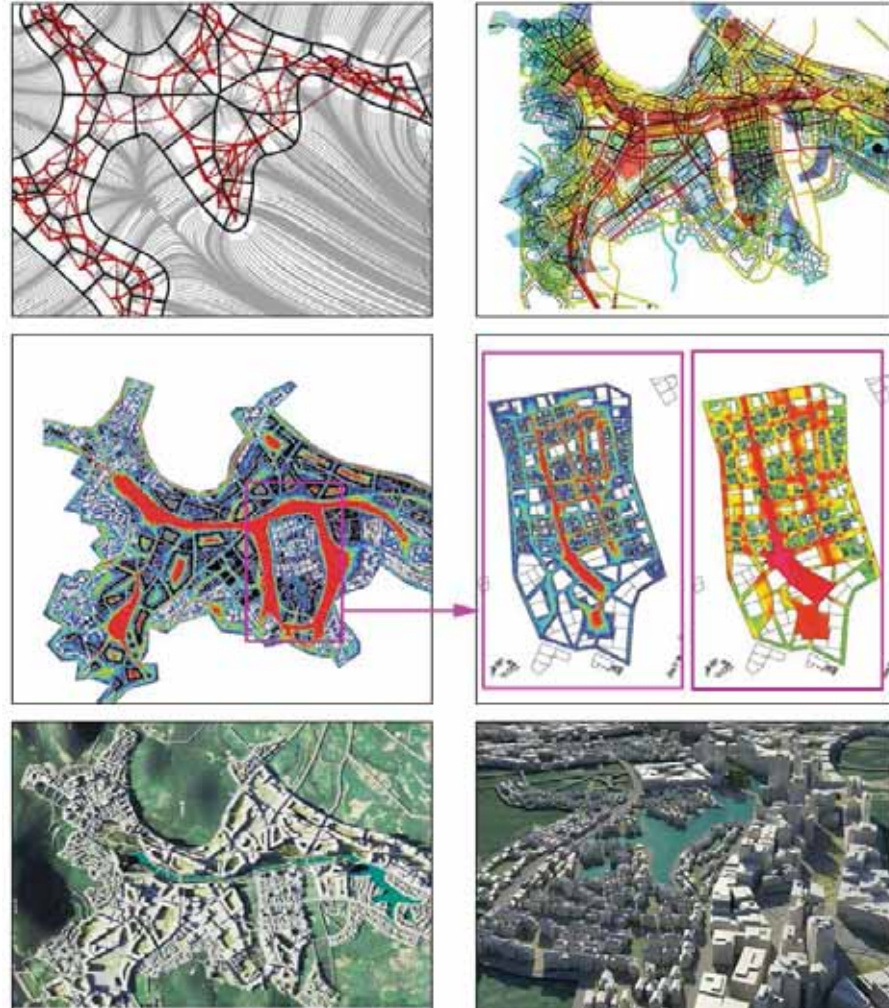

Figure 6. Adaptive urban model, Zhuhai, China.

3.2. Dalian, HYK district

In the second project, we were commissioned to design a 2,000,000 square meter district as a central hub and public space in the HYK economic zone, Dalian, China. Together with the multi-purpose buildings surrounded, the project required a mix use CBD blended with residential, commercial, business, tourism and education programs as a whole. In our proposal, the idea of “slow life” and “slow movement” were realized by introducing bottom-up self-organizing pedestrian network based on the existing attractions such as natural landscape, landmarks and commercial centers. The three-phase ABS method was executed and produced organic movement pattern on top of the existing recliner infrastructure. This new superimposed movement network serves as the stimuli to rebuild vacant lots and re-links

various green corridors back to the natural landscape. The self-organizing pattern and conceptual model were further developed by architects, urban designers and planners to fit to the local context and program needs. (Figure 7)



Figure 7: HYK district. To investigate the pedestrian movement in a complex spatial configuration, we evaluated and optimized the self-organizing pattern developed in the first phase. Project team: Dalia Dushifazhan Design Institute, Ming Tang, Xinhao Wang, Arefi Mahyar, University of Cincinnati

4.0 CONCLUSION

Both projects demonstrated the bottom-up ABS are capable in generating characteristic movement networks. The generated paths were then analyzed based on the accessibility in space syntax. The result was coded in “attraction map” and drove the construction of a proxy urban model. Additional research interests center around the marriage between the “hidden hand” human supervision and computer-controlled automation. As Li and Xue argued in their multi-agent system “all agents are under controlled by human supervision.” (Li, 2008) There is an apparent need of a solution that integrates the wide variety of agent-based tools available today. It allows designers to generate and evaluate design iterations in a computational way. In conclusion, combining the traditional method of evaluation with ABS, a new relationship of designer and design agent has been forged. Within the bottom-up process of creation, design is now understood as a result of the interaction of agents and their environment, and the modulation of agents’ behaviors to react both physical and social patterns.

However, we do discovered several constraints of our linear three-phase method. First, the ABS movement network was generated as a driving force for the entire urban modeling without consider the proposed building settlements. The movement pattern was isolated from the influence of the later evolved building cluster. In an ideal situation, the building blocks and settlement structure should be able to affect the ABS movement pattern and serve as a feedback loop. Most likely, a minor influence from the building block can impact agent’s behavior and produce a totally different movement pattern.

The second constraint of this method is the creation of “attraction map” using space syntax and other GIS data. How to combine a large number of data generated from various data source and merge them into one single “attraction map”? The map needs encode a large quantity of abstract analytical data, including the accessibility map of space syntax. However, each of the data set only responds to one specific design aspect. How to judge the confliction between these data is a big challenge during the evaluation. When we have many abstract data responding to various geographical, social, political and economic features simultaneously, it is difficult for a designer to find an appropriate middle ground and create one single “abstract map”.

The future development is also focusing on the integration of space syntax into the bottom-up process. To create meaningful urban forms in an ideal ABS environment, designers should be able to continuously feed the analytical result of space syntax into the optimization loop, and guide the self-organizing process with constant modifications. Once this is achieved, the ABS can be used as a truly synthetic assistant.

ACKNOWLEDGEMENTS

Thanks for the contribution from Dallas Puckett, Derek Morpew, James DiMeolo, Yiren Weng, Trey Meyer, Boer Deng, Guande Wu, Ladan Zarabadi, Xinhao Wang, Arefi Mahyar at University of Cincinnati, and design team from Dalian Dushifazhan Institute in China.

REFERENCES

- Batty, Michael. *Cities and Complexity, Understanding Cities with Cellular Automata, Agent-Based Models, and Fractals*. MIT Press. 2007
- David Gerber. Rorigo Shiordia Lopex. Context-aware multi-agent systems. ACADIA conference proceeding. 2014.
- Tom Verebes. Masterplaning the adaptive city. Computational urbanism in the Twenty-First Century. Routledge. London. 2014.
- Batty, Michael. c1983, *Environment and planning B: planning and Design*, London: Pion Ltd
- Ehsan Baharlou¹, Achim Menges² *Generative Agent-Based Design Computation , Integrating material formation and construction constraints*. Ecaade 2013, 2013.
- Anandan Karunakaran, *Organization of Pedestrian Movements: An Agent-based Approach*. Eccadria 2005
- Sehnaz Cenani, Gülen Çağdaş *Agent-Based System for Modeling User Behavior in Shopping Mall*. Ecaade2008 proceeding. 2008
- Gideon Aschwanden, *Agent-Based Social Pedestrian Simulation for the Validation of Urban Planning Recommendations*, sigradi 2012.
- Li Biao, Li Rong, Xue Kai, Liu Chang, and Gao Qin, *A generative Tool Based on Multi-agent system: Algorithm of "HighFAR" and Its Computer Programming*. CAADRIA 2008.
- Peter Buš , *Emergence as a Design Strategy in Urban Development Using agent-oriented modeling in simulation of reconfiguration of the urban structure* ecaade 2012
- Sehnaz Cenani ¹, Gülen Çağdaş, *Agent-Based System for Modeling User Behavior in Shopping Malls*, MallSim. Ecaade 2008
- Hao Hua and Ting-Li Jia, *Floating Bubbles, An agent-based system for layout planning*, CAADRIA 2010
- Ben Coorey, *Scalability, Parametric studies from exoskeletons to the city*. New Frontiers: Proceedings of the 15th CAADRIA 2010.
- Saied Zarrinmehr, Mohammad Rahmani Asl, Wei Yan, Mark J. Clayton. *Optimizing Building Layout to Minimize the Level of Danger in Panic Evacuation Using Genetic Algorithm and Agent-based Crowd Simulation*. 2014.

ENDNOTES

¹ Batty defined the environment as a cell-based landscape and agents as "objects or events that are located with respect to cells but can move between cells" (Batty 2007). Agents are objects that do not have fixed locations but act and interact with one another as well as the environment in which they exist according to some purpose.

² Batty researched on how the simple movement and resource exploitation actions on heterogeneous landscape can produce various settlement distributions. (Batty 2007)

³ Frei Otto's wool-thread machine is a form of an analog computer. Analog computers use a continuously changing aspect of a physical phenomenon to model a problem being solved. Otto's wool-thread machines change the degree of freedom that water (a physical phenomenon) can act on the wool threads. By changing the degree water acts on the wool threads, Otto solves the problem of path optimization. The end geometry is a result of material interaction, elasticity, and variability.

⁴The name of "attraction map" is from Batty's "attraction surface" in his urban growth ABS.

Evolutionary parametric analysis for optimizing spatial adjacencies

Christopher Boon¹, Corey T. Griffin¹, Nicholas Papaefthimiou², Jonah Ross², Kip Storey²

¹Portland State University, Portland, OR

²ZGF Architects, Portland, OR

ABSTRACT: This research utilizes parametric and evolutionary software in order to create an analytical system intended to enhance efficiency within groups of complexly interconnected architectural program elements. The authors have developed a parametric definition that can diagrammatically arrange spatial volumes. These volumes represent the various building functions or 'programs' in terms of square footage. The driving parameter for these experiments is adjacency; if two functions in a building need to be connected, they should be adjacent to one another. The degree of adjacency is here viewed as the distance between the centers of programmatic masses. The distance between programs is scored as a numerical value, the lower the value, the closer the programs, and the better the score. The resulting model contains a complete set of programs all arranged within a larger volumetric container. This container represents the building shell. Each arrangement represents an individual iteration. The script automatically creates individuals and store their information in groups referred to as 'generations'. The evolutionary process improves the proximity score over the course of many generations. The resulting spatial diagrams produced autonomously by the computer are sorted, and the computer determines fitness by minimizing the numerical value of the total distance of all interconnected programmatic elements. This type of approach offers a unique system of analysis that can create an incredibly extensive range of unique and otherwise unexplored solutions when faced with problems in developing complex order for spatial relationships. This script is a significant leap forward over existing research in this area with the ability for users to define an irregular shaped site boundary, input multiple stories, relate program elements to external adjacencies (views, parking, etc.) and handle an unlimited number of program elements. This paper uses a three-story hospital on a sloping site with fifty program elements to demonstrate the efficacy of this approach.

KEYWORDS: Programming, Evolution, Parametric, Spatial Adjacency

INTRODUCTION

Emerging parametric technologies are opening new opportunities in architecture. Generally it is seen primarily as an engine to drive formal explorations and renderings. Its implications however are larger and it is possible to employ it at many stages in the design process. During the initial design stage, much of what is explored involves theoretical concepts. The work is expressed diagrammatically. If the concept can be distilled to its parameters, then it is possible to begin including parametric analysis. This type of analysis will allow designers to develop a much wider range of options in a much shorter timeframe. This study intends to explore the ability of evolutionary parametric modeling as a diagram-building tool. For a building to be efficient it must meet the needs of its occupants. The needs of the occupants are determined during the design process by a complex relationship of programmatic and physical situations. These situations can be measured and used as metric data; which can be translated into parameters.

1.0 PARAMETRIC AND EVOLUTIONARY DESIGN

1.1. Parametric design

Roller (1991) discusses the way specific information storage (parametric information) in combination with construction process has the potential to capture an extremely true version of design intent, while the benefits of iterative variation in the design process are examined. Motta (1999) focuses on computer aided, intelligent modelling systems, illustrating their widespread application and value as tools that have the potential for reuse. Precedents in parametric design highlight the importance of establishing a workflow that produces successful results in this field.

1.2. Evolutionary design

Lenski, et al. (1999) explores the ability of digital models to evolve like organisms in nature. Through experimentation, they attempt to find the best possible way to create a digital genome, and how influences that are inherent in nature, such as mutation, can affect the population. The authors use diagrams to help explain the methods that can achieve the fittest results.

1.3. Previous parametric tools for programming

Scrawford (2010) makes use of a detailed set of spreadsheets to create architectural geometry based on programmatic relationships. The tool arranges based on relationships marked within the information on the spreadsheets, and translated into individual spaces that organize themselves according to hierarchy. Definition is displayed to observe logic. The architecture firm NBBJ created a video of their parametric conceptual design tool for architectural practice that allows designers to quickly organize and understand complex architectural programs in three dimensions (Syp, 2010). The project uses spring physics to create gravity between the various elements, which are represented by spherical volumes.

1.4. Goals for a new optimization tool

This paper explores the utilization of Grasshopper (a Rhino Plugin) as an analytical and planning tool to graphically represent a 3-dimensional analysis of adjacency requirements in program and spaces. The purpose of this paper and research project is to explore and innovate new ways of further utilizing the technology in evolutionary algorithms or physics modelers to reduce inefficiencies in the design process as well as optimize floor-plan layouts. The tool developed in this research uses digital, generative tools to create spatial diagrams using adjacency requirements. The resulting tool can be used as an aid in the massing of buildings that have inherently complex programmatic relationships.

The ideal outcome will have the ability to reduce inefficiencies in the design process and optimize floor plan layouts in a single motion. The rapid iterative process takes ideas further in less time by letting the computer tirelessly work away at a problem that has a defined set of parameters created by the designer. This type of approach offers a unique system of analysis that can create an incredibly extensive range of unique and otherwise unexplored solutions when faced with problems in developing complex order for spatial relationships.

2.0 Methodology

2.1. Design directive

Programming for a building like a health care facility is an especially difficult job. This is due to the high level of complexity in spatial relationships and high number of programmatic elements. This is an ideal building program to test the tool on. A hospital also requires a high level of efficiency due to the nature of its function in society.

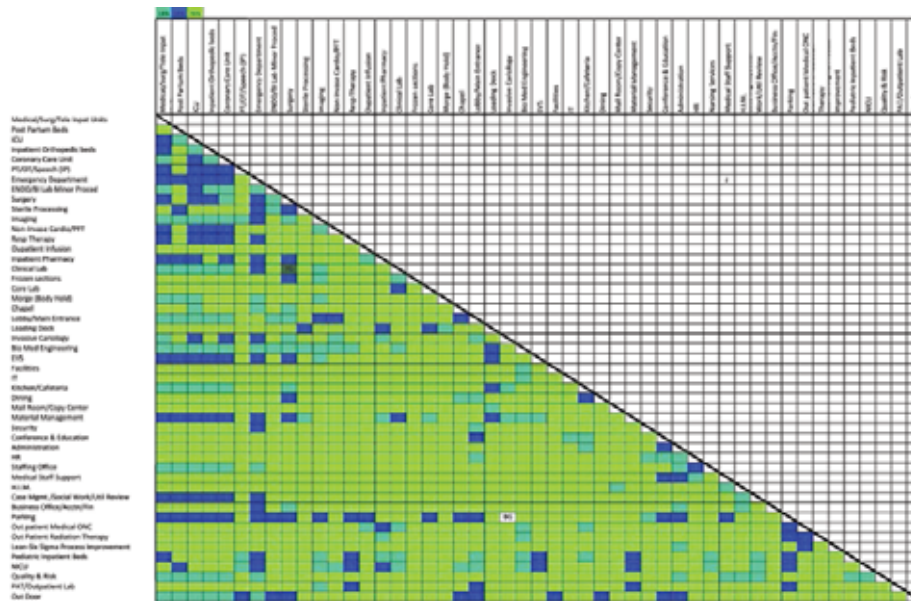

Figure 1: This matrix shows the various programmatic elements for a hospital and the relationship with others. There are three different levels of importance indicated by tones. Source: ZGF Architecture

ZGF has a great amount of experience designing hospitals. With expertise, one can rely on research and intuition to achieve efficiency in spatial relationships. At the beginning of this research, ZGF was in process of designing a hospital, and there were program adjacency charts generated at client meetings and these resources were made available as sample test figures. The numbers on the charts represent the various needs of the client. At meetings, the design team and clients develop a matrix of all the discrete programmatic elements. The matrix forms a hierarchy of space in terms of priority and ranks the adjacency requirement of each element in relation to all other elements in the chart. A space like the emergency room would take priority over the gift shop for example, and the two have no adjacency need.

2.2. Tool development

The definition begins by input of some simple geometric parameters, thereby establishing the programmatic volumes that will be used in the iterative process. These first steps are the customizable portions of the tool. Each unique architectural situation requires some unique combination of factors that this research attempts to address to some extent in terms of spatial proxemics. The potential floor plan space is all that is actually drawn by the user. The ground floor of the building or site outline is first drawn and then additional floors can be added of any shape. Floor to ceiling height is adjustable. Any number of floors is allowed and there can be multiple sites separated from one another. Any shape can be used to describe the boundary conditions. The tool will automatically fill in the shapes with a three dimensional, rectilinear grid that can also be adjusted as desired.

The geometry all occurs within a three dimensional grid. This begins to describe a structural system. All of the cells in the grid are marked with a single point. These points are all contained in a cloud. Each programmatic element is also built around a single point. The programmatic central points are here referred to as 'origins'. Within the list of programs itself there exists an explicit hierarchy. That is to say, the first program on the list dominates the second, which dominates the third and so on. The first program is placed in the grid by selecting one of the points in the cloud. The selected point becomes the center of the mass, which forms as a pixelated sphere around that point. Once a program occupies a space, all points within it are subtracted from the cloud. The next program repeats the process until all the programs are massed out. The proximity is determined by measuring the distance between origin points. The relationships are weighted in terms of their needs by multiplying the distances by various factors, the higher priority the adjacency need, the higher the multiplication factor. The tool calculates the total value of all relationships by performing mass addition. This figure is the fitness score. The evolutionary process tries to minimize this number as much as possible. The idea is that a lower score creates a closer proximity and a more effectively adjacent situation.

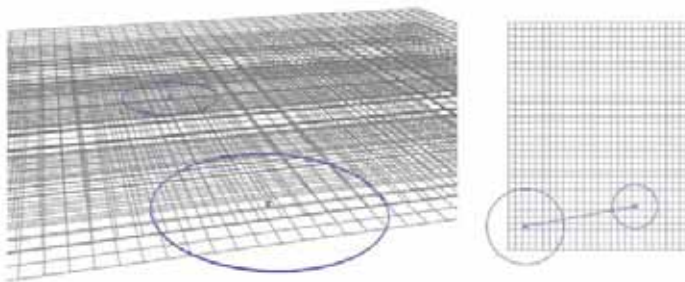

Figure 2: Screenshots showing the origin points selected in the grid and the relative floor area of each. Source: Author

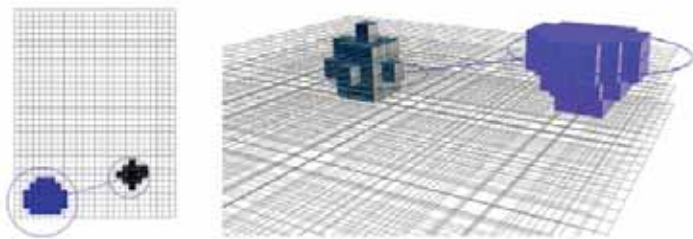

Figure 3: Areas are translated into "pixelated spheres". Source: Author

To create the evolutionary element in the process, the computer is allowed to manipulate all the origin points to create iterations. The point cloud within the shell is a list, and Galapagos can iterate using the sliders connected to that list.

2.3. Tool demonstration and steps

A series of generic tests help to demonstrate how the system works and where it needs refinement. This test was run with nine programmatic elements. Those are broken into three groups represented by three differently colored groups. Each group member wants to be adjacent to the others in the same group. The site outline for this experiment is for square blocks. There are four floors to be occupied. The Grasshopper definition (Figure 4) is implemented using the steps outlined in Figure 5 and described in more detail below.

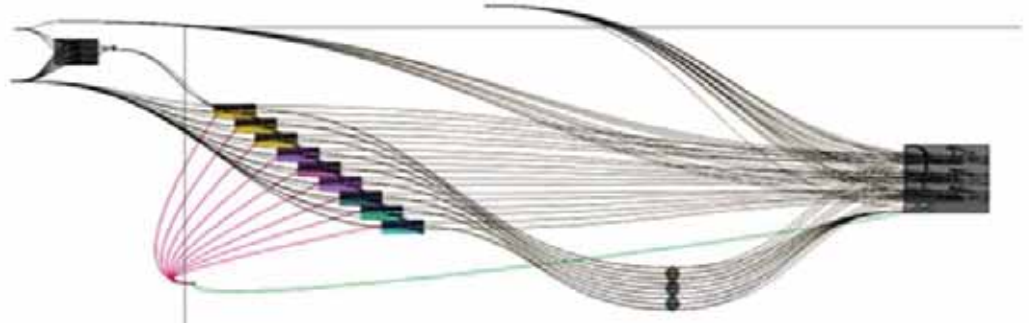

Figure 4: Grasshopper definition, screenshot colors represent program groupings. Source: Author



Figure 5: Diagram outlining the software programs and steps used to generate adjacency diagrams. Source: Author

Step 1 – Establish site-specific initial geometry and offset levels

The starting parameters are customizable. The user sets up a grid that the spaces are built within. The number of cells and size of cells can be set to a specific coarseness. The program can also build the grid inside of a two-dimensional site outline to accommodate non-rectilinear sites. To account for multiple levels the grid can be offset vertically any number of times and the floor-to-floor height is adjustable (Figure 6).

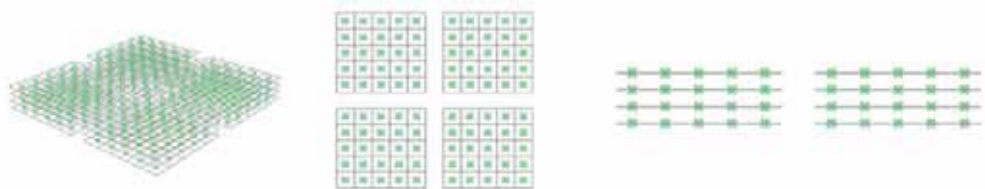

Figure 6: Point cloud formation, derived from initial geometry: site outlines and offset floors. Source: Author

Step 2 – Assign hierarchy of spaces with list order

When the program activates, the order of the list of program elements is the order of importance. The first element in the list is ranked as the most important. This hierarchy is applied when spaces are divided and reassigned giving priority to the most important program elements.

Step 3 – Input square footage and set initial locations for each program element

The square footage for each space is set using a slider in the Grasshopper definition. The various program elements are assigned an initial origin point in the grid for a starting location. This point is center of the pixelated sphere, which represents a program element in the definition.

Step 4 – Generate adjacency lines between program elements

The definition creates a line connecting the origin points for every adjacency requirement. A lower value indicates a closer proximity and more optimized adjacency. The definition adds up the total distance of all adjacency lines, which can be weighted to create greater attraction or repulsion in order to prioritize certain adjacencies over others or ensure two program elements are isolated from one another. The Galapagos evolutionary solver will try to minimize this total distance to improve fitness.

Step 5 – Run Galapagos and record visualizations of every iteration

The Galapagos “genome” is solely made of the origin location sliders, which allows it to rearrange the location of the program elements within the grid in order to improve fitness by creating the lowest total

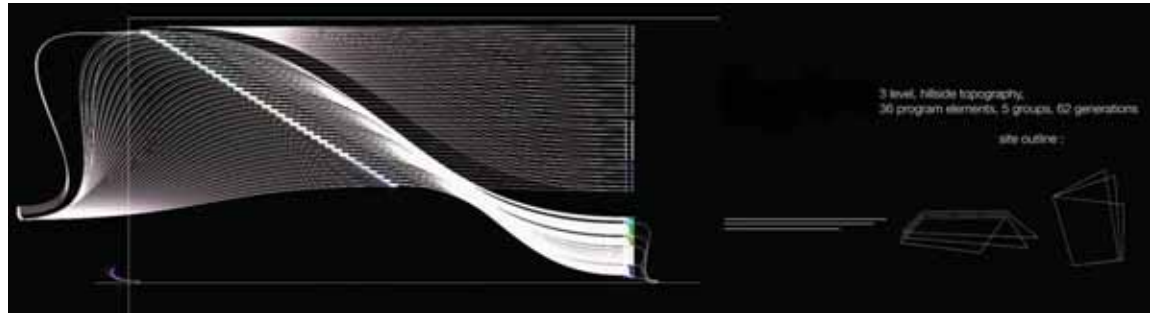

Figure 10: Grasshopper definition (left) and site constraints (right). Source: Author

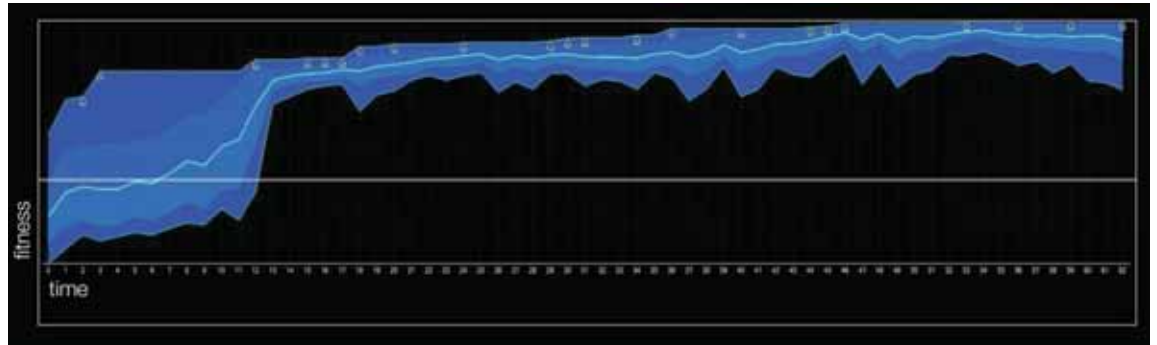

Figure 11: Graph depicts fitness variation(y) over generation number (x). 62 generations took 8 hours. Source: Author

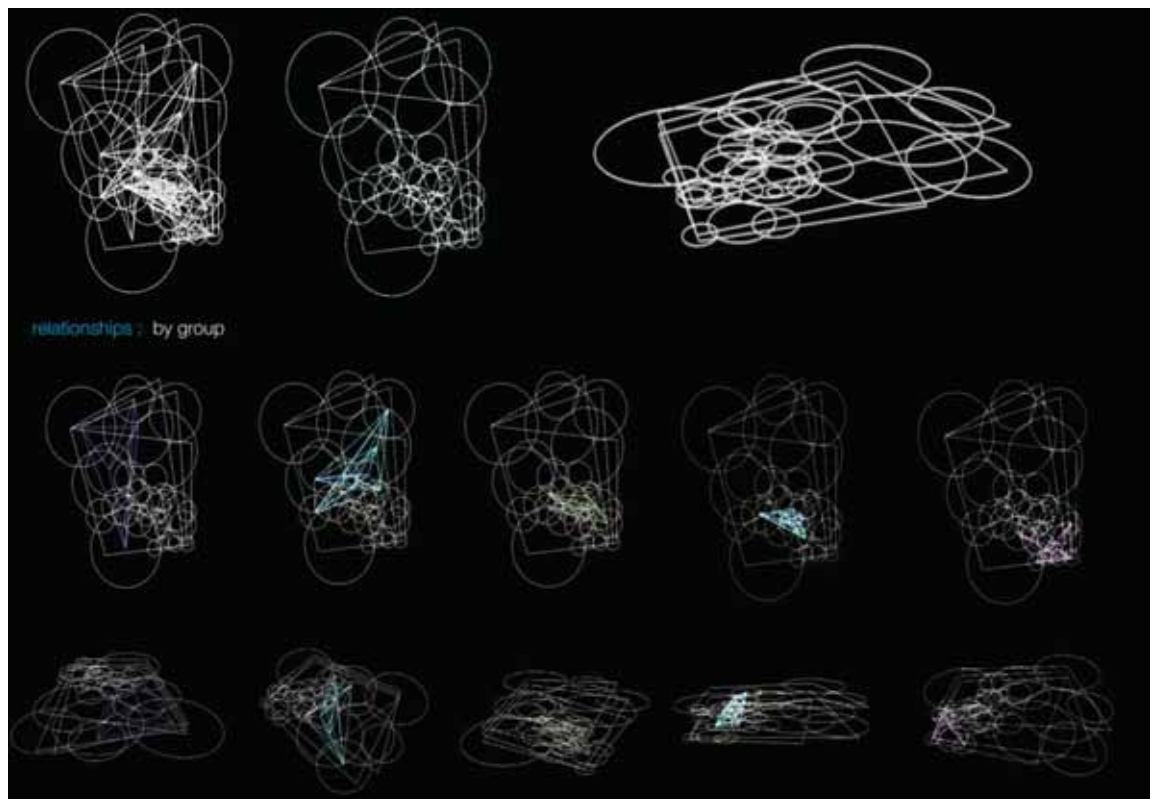

Figure 12: Generations, highlighting the geometries and distances used to optimize adjacencies and relationships by program type ("group"). Source: Author

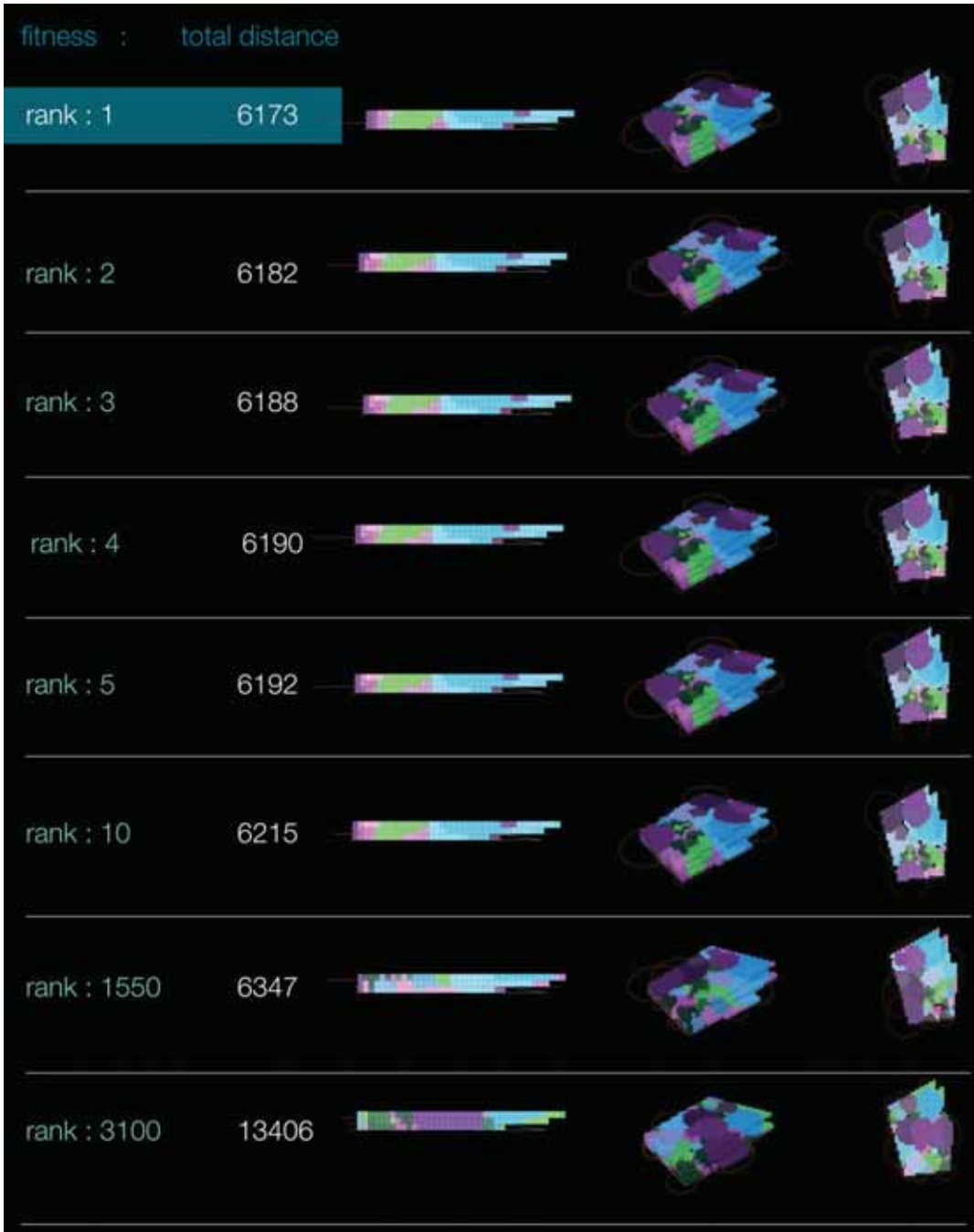

Figure 13: Least fit result (bottom) and most fit result (top) in section, isometric and plan. Source: Author

CONCLUSION

The tool can be applied in a wide variety of situations in the early design phases. It can give designers metric data to inform their process and justify their decisions. The adaptability of the tool is critical to its usefulness. It has been simplified in terms of the scripting to a large degree but could perhaps still be refined to produce faster results. One observation from the experiments however is that the best way to save time is by sacrificing certain amounts flexibility. The more customizable the tool becomes, the more complex the calculation.

The tool can run indefinitely though it reaches a point where the results show no serious improvement. At these points it is best to either stop the process and take best result, or continue by restarting the process,

and hope for a different type of mutation to take hold of the evolutionary direction. There are clearly many ways to achieve similar results within the structure of the parametric tools, so this is just one solution to a problem that can be answered in many ways. Better definitions are ones that can accomplish complex moves within a few commands, this makes the load on the computer exponentially lighter and therefore it produces more results and is easier to use.

The introduction of the evolutionary process is extremely useful in creating iterative tools. Evolutionary algorithms are the way in which computer can independently handle time consuming iterative work. The ideal situation for the tool involves a combination of parametric operations with evolutionary solving. Then the tool is actually thinking and becomes more like a partner or double.

Creating the range for the results is the task of the designer, and the narrower the range, the more meaningful results are. In other words, narrowing the field where variables can occur creates more pertinent results. The end results of this definition are diagrammatic, so they serve as a source of information that can be observed as a metric then incorporated into design. It could be expanded into a more literal space, with doors and windows etc., and the results could become more directly applicable to building design in the later stages.

In general, the evolutionary modeling methods could be utilized on a much wider range of situations. Here research explored adjacency but any parameter or combination of parameters could be driving the model process. The evolutionary process enhances this practice. As a diagramming tool, parametric engines allow designers to start their process from an informed standpoint. The authors believe these methods are sound, but it will take further tests that lead to actual buildings that would later have to be evaluated to find out if the methods yield actual results that are effective.

ACKNOWLEDGEMENTS

The authors would like to thank the Oregon Community Foundation for funding the seminars in which this research was conducted. The authors would also like to thank ZGF Architects for their collaboration on this research.

REFERENCES

- Lenski, R.E., Ofira, C., Collier T.C., Adami, C. 1999. "Genome Complexity, Robustness and Genetic Interaction in Digital Organisms" in *Nature*, Vol 400. (Macmillan Magazines Ltd.) 661-664
- Motta, E. 1999. *Reusable Components for Knowledge Modeling: Case Studies in Parametric Design Problem Solving*. Amsterdam, IOS Press.
- Roller, D. 1991. "An approach to computer aided-parametric design" in *Computer-Aided Design* Vol.23, Issue 5. Böblingen, Hewlett Packard.
- Samuel, Flora. 2010. *Le Corbusier and the Architectural Promenade*. Basel: Birkhauser.
- Scrawford. 2010 "Grasshopper Space Planner." last modified 18 Jan.
<http://lmnts.lmnarchitects.com/parametrics/grasshopper-space-planner/>
- Syp, Marc. 2010. "Architecture: Realtime Physics for Space Planning." Vimeo. N.p., last modified 3 Mar.
<http://vimeo.com/15563685>

Leveraging data in academia and practice: Geometry, human- and building-performance

Randall Deutsch ¹

¹University of Illinois at Urbana-Champaign, Urbana, IL

ABSTRACT: Data plays an increasingly critical role in every facet of the building lifecycle, from design and construction to building operations. Data is used in design and planning to not only generate designs and create interesting geometry, but to help designers acquire insights and answers out of the information they are already working with to validate their outcomes. The acquisition and leveraging of data will become a critical practice approach with implications for defining the future course of architectural research. Specifically, data helps increase energy and building performance and improves productivity, enhancing human and operational performance, as it predicts a facility's future performance; eliminates emotion from the decision-making process, allows teams to make decisions with more confidence by proving that initial concepts were right; and provides objective evaluations of all aspects of the built environment.

Based on qualitative research involving interviews and observation of the work of 40 practitioners (30 professionals and 10 academics) across the globe, and sharing their recommendations, insights and strategies, this approach to research addresses a gap in our professional learning, by researching how architects, engineers, contractors and owners – and educators in these fields – acquire and use data to make more informed decisions. Data informed design is a trend in architecture/ engineering/ construction/ operations (AECO) that is just starting to gain notice, and is the new frontier of the convergence between building information modeling (BIM) and architectural computational analyses, associated processes and technologies. There's a need for research that shows not only why design and construction professionals need to understand where data and analysis fits into their practices, but also how they can use data and analysis to meet and exceed their client's expectations.

Keywords: Data, Building Performance, Analysis, Analytics, Computational Design

INTRODUCTION

This paper focuses on the opportunities and challenges of capturing, analyzing and applying building data. It asks, and seeks to answer; important questions that design and construction professionals, owners and their teams, need to clarify in order to proceed with their design agendas. The research methodology looks inside practices of all sizes to observe how people in the architecture/ engineering/ construction/ operations (AECO) industry today are leveraging data in their day-to-day work. Accordingly, individuals and organizations in the profession and industry are already leveraging data, and for some firms have been doing so for some time to considerable effect and results. Based on research involving interviews and observations of the work of 40 professionals (30 practitioners and 10 academics) across the globe, and sharing their recommendations, insights and strategies, this approach addresses a gap in our professional learning, by researching how architects, engineers, contractors and owners – and educators in these fields – acquire and use data to make more informed decisions.

There is a need for research that explains not only why design and construction professionals need to understand where data and analysis fits into their practices, but also how they can go about using data and analysis to meet and exceed their clients' expectations. Based on the aforementioned interviews and on-site observations, the acquisition, leveraging and application of data is becoming a critical practice and research approach for many current practices, with implications for defining the future course of architectural research. Design and construction professionals need to increase productivity [Teicholz, 2013.] Based on this research, data helps increase energy and building performance and improves productivity, enhancing human and operational performance, as it predicts a facility's future performance. Data also eliminates emotion from the decision-making process, allows teams to make decisions with more confidence by proving that their initial concepts were right, and provides objective evaluations of all aspects of our built environment.

Data is changing the way we work in the AECO industry, and has the potential to change how we learn. Practitioners and educators have already dealt with successive disruptive technologies – computer aided design (CAD), building information modeling (BIM), digital-, parametric-, and computational-design tools, to name a few – and aren't certain if they're prepared for another. As though to say, aren't architecture, engineering and construction already complex and complicated enough? These are all ways of saying the same thing: that data is *one more thing*. As the research bears out, looking at, capturing, engaging with, analyzing, and applying data is not "one more thing." As this paper attempts to make clear, data is not

something *added* on to what design professionals, educators and researchers are currently doing, but rather something that is *integral* to what they do and have been doing, even if not historically always accomplished computationally.

In the interviews, design and AECO industry professionals indicate that they realize that data is the answer to their most perplexing professional and business problems – but suspect that many others are still unfamiliar with the steps necessary to acquire and use the data that will enable them to do their jobs better, remain competitive and achieve a higher return on their technology and training investment. Even more than the acquisition of new skillsets and technological capabilities, to reclaim their role as leaders, those interviewed believe that architects in particular need to simultaneously account for data and information derived from their digital models, and also be able to gather, navigate and communicate this information while working collaboratively through the project cycle. As the research indicates, all activities that we undertake today can be transformed into data – one only needs to know where to look to find it. The data, in other words, already exists – in abundance – and represents an opportunity that the profession cannot afford to ignore. This paper attempts to help state this more clearly and readily.

1.0 DESIGN COMPUTATION IN PRACTICE

One challenge in working with design computation in the AECO industry can be attributed to how firms perceive themselves in relation to data. Terminology needs to be defined before we can consider if there is as an ideal firm approach to data. Another challenge is the recognition that all forms of analysis ought to be considered when working with computational tools for integrating building-, human- and firm-performance. Learning to work more effectively with data will take not only newly acquired skills, such as the use of computational tools, but also the development of appropriate mindsets.

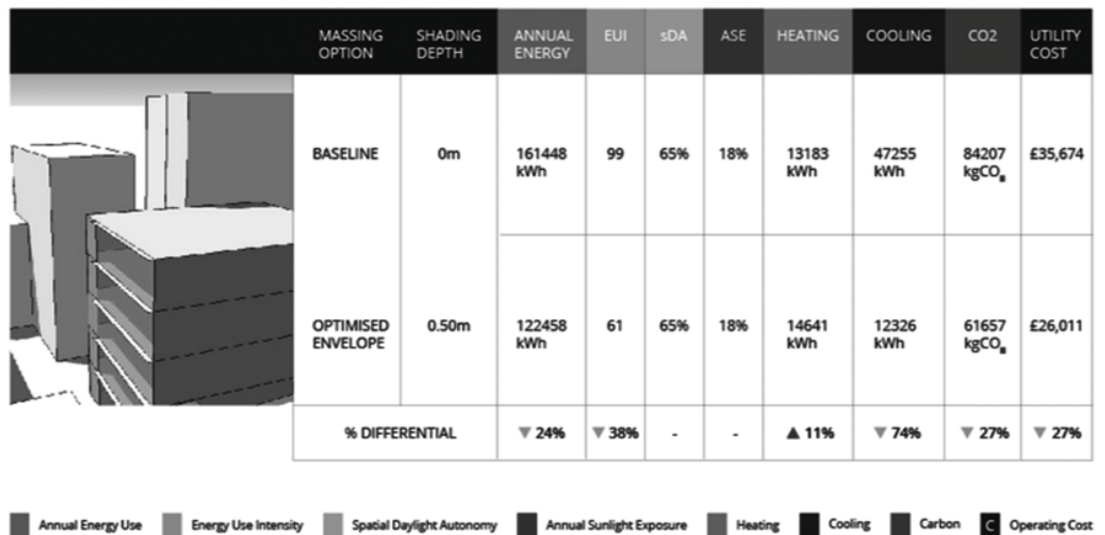

Figure 1: Baseline vs. Optimized Building Comparison: A representation of analysis results from Sefaira, showing the savings offered by an optimized envelope. (Sefaira Inc., 2014)

1.1. Tools and process

Firms are currently exploiting and innovating with computational design tools to make decisions in real- or near real-time. Design computation, software programs that use algorithms to link geometry with data to address specific problems, are utilized primarily to create geometry, for better building performance, or for both. According to Ryan Mullenix, Design Partner at NBBJ,

It's all intertwined. The evolution of design computation has had moments of focus. Computation really started with building geometry. Part of it was as a cool tool with intriguing results. Part of it was, hey, this could lead to new means of fabrication; it could lead to efficiencies in the field. Then we got into building performance and the analyses we could perform to understand how a building was going to work within an environment. (Mullenix, 2014)

The goal ought to be where it is all put together – where geometry, human and building performance are inseparable – integrating building, human and firm performance.

Whether for geometry, human, or building performance – energy, sustainability, commissioning, lifecycle – it is important for design professionals to be able to test assumptions quickly in the early design phases.

Analysis will tell teams how well they are doing – how close to targeted goals they are. While the emphasis can overwhelmingly be on analysis for building geometry or energy, data can also be made available to the designer for analyzing the flow of people through space using software for simulating pedestrians and analyzing crowds. All forms of analysis ought to be considered when working with computational tools.

According to Robert Yori, Senior Digital Design Manager at SOM,

In the broad sense, dealing with massive amounts of data is something architects have always done, although much of it hasn't historically been computational. The core question is this - how can we utilize the myriad types of data in a way to better our projects? (Yori, 2014)

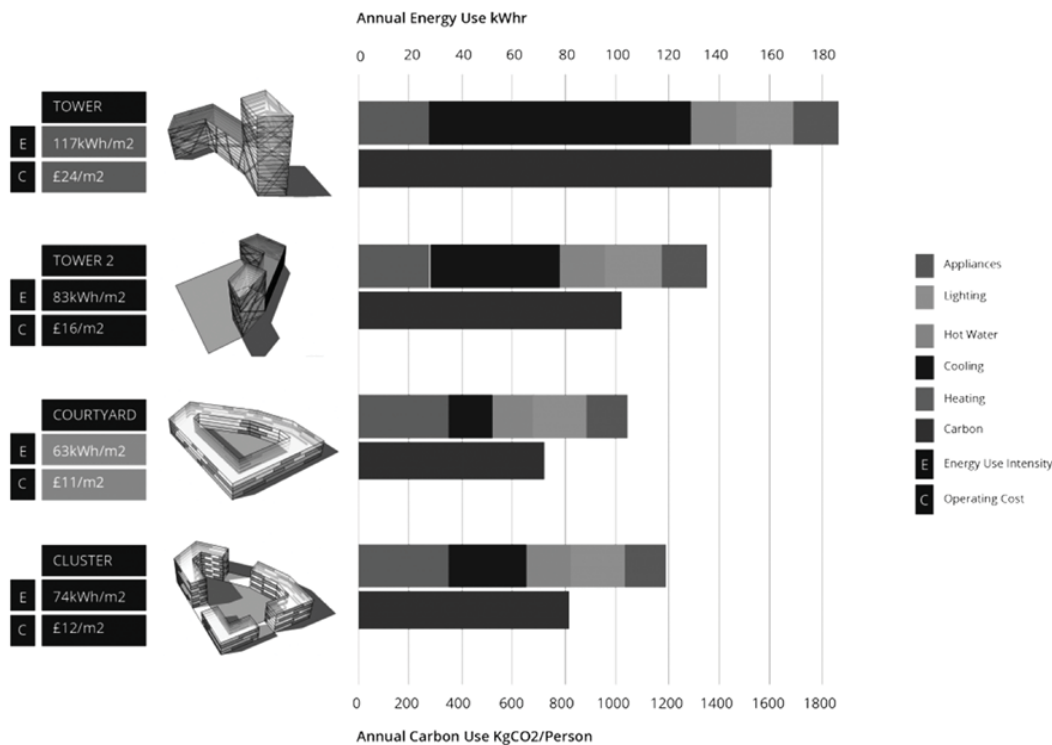

Figure 2: Building comparisons: Sefaira allows architects compare design options and measure their performance using chosen parameters. (Sefaira Inc., 2014)

1.2. Data informed: the middle ground

Before we can consider if there is an ideal firm approach to data – whether one should strive to be a data-enabled, data-informed, data-driven practice – we need to define the terms. Data-driven: where data is the primary priority, involving up to 80% machine/algorithm input to 20% human intervention or override. At the other extreme, Data-enabled: where one is aware of the data but not leveraging it. A Data informed approach represents the middle ground: using data as a factor in the decision-making process.

Data informed design is a trend in AECO that is just starting to gain notice, and is the new frontier of the convergence between BIM and architectural computational analyses and its associated technologies. Does a firm like SOM – a firm that helped launch AEC-APPs and regularly queries their BIM models for pertinent data – consider itself data driven? “I can’t characterize the whole firm one way, but certainly aspects of what we do at SOM are data-driven,” says Yori, but adds, “and some are data-informed.” As with the data-enabled approach, the choice is situational:

There is some information that is better suited to being data-driven and some that is less so. So holistically, when we are approaching design, I would have to go with data-informed. Because there are some things that we do that are data-intensive. Some things that we do aren’t so much. (Yori, 2014)

1.3. Capitalizing on data

How can we capitalize on data to drive innovation in architecture and construction? Learning to work more effectively with data will take some newly acquired skills. But even more important, especially at the beginning of this effort, is the development of appropriate mindsets. BIM is a case in point. While recognizing the value of BIM, most still use BIM tools today for document creation, at a time when design and construction professionals need to recognize BIM’s real value: as a database, and start treating it like

one. How we use and interact with the data generated in BIM enabled projects is the next step in BIM adoption. Learning to capture, analyze and apply data is how many of us will take BIM, beyond visualization, clash detection and coordination, to the next level. One challenge to working with data in the AECO industry can be attributed to firms and how they perceive themselves in terms of data.

2.0 FIRM CULTURE, DEMOGRAPHICS, AND GENERATIONS

Will architects and other design and construction professionals need to adapt to working with, even alongside, data scientists and analytics experts? Some firms already have architects working alongside data scientists and analytics experts. Whether they do so comes down to firm size, their strategy, but as importantly, firm culture. Firm culture, the demographics and generations that make up the workforce, all make working with data challenging. “Data is different – it’s new and it’s scary,” explains Evelyn Lee, Strategist at MKThink, acknowledging that data’s challenges begin in school:

With the current architecture curriculums, I don’t think any of the students graduating right now have an issue with working with data. A lot of these programs have a cross-over with geographic information system (GIS) and energy modeling, which requires data. If you asked any of these graduates, they would tell you they would love to find a firm where I could put all of this into action. (Lee, 2014)

Yet, the same cannot be said for practitioners who are out of school:

You ask a majority of firm leaders, though, in the architecture profession – and we all know that the architecture profession suffers from a generation gap – and they don’t know what to make of it – data – and specifically how to apply it in a meaningful way. Individuals who have been around 10-20 years tend to be averse to it. In many instances, they are scared of finding out that the post-occupancy evaluation results tells them that their design was horribly designed. (Lee, 2014)

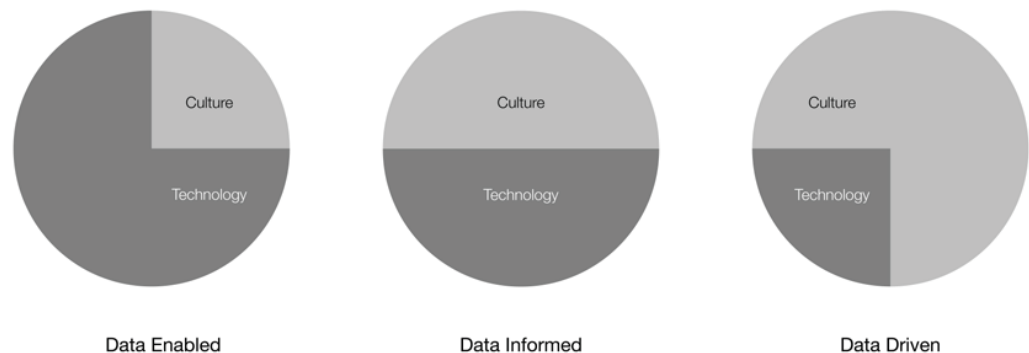

Figure 3: To become data-centric, the core of efforts ought to be focused on firm culture, not technology. (Deutsch, 2014)

3.0 LEVERAGING DATA IN EDUCATION

Should working with data be introduced into the college curriculum? Or will there be better results and increased impact if those in the profession and industry address data use in practice? There are many questions concerning when it is best to become exposed to integrating data analysis in the design process. But are there answers?

3.1. Addressing data from the start

Data is changing the way we work in the AECO industry – but is it having a similar impact on the way we learn? Just as data may be challenging to older generations, younger generations have the opposite problem. They may get so used to working with data they miss opportunities for developing or exercising critical thinking, or learning what the data is based on. Says Brian Ringley, educator at City Tech (CUNY) and Pratt Institute’s GAUD:

In the early stages of data-as-justification – we think of data-as-design-generator but also as justification of something to a client, public or team – there’s justification of stuff we already know. We see this so often with students: the sun is always in the same spot this time of year. OK, we got that. (Ringley, 2014)

Ringley provides an example of how schools are exploiting and innovating with computational design tools to make decisions in real time:

At one point, when teaching DIVA, I realized we needed to build a physical model, and that I needed to give them a crayon and have them color in where the insulation is occurring. Because it is as if once the data is there, common sense just falls to the wayside. We need to understand where the sun is relative to the building – go to the planetarium – before we get into this. A danger of introducing software at too early

a stage in their education is that they were doing all the steps right – the workflow, the Grasshopper noodles were plugged in where they were supposed to go – but they had inverted the logic. So that the building was shading where there was no sun, windows were opening up where there was way too much sun. But they did all the steps right. That is a huge danger of data – I’m speaking here beyond the students and to the firm as a whole – there is trust in data that removes our critical thinking. We need to be careful about that and have ways to validate rules of thumb we already know. (Ringley, 2014)

Bringing attention to the topic of data ought to incentivize university programs to begin to address this topic in school, which does not happen often enough today. Students today are surprisingly unaware of issues related to leveraging data within architecture and construction management schools. This understanding and advanced use of data comes down to not only how, but when, one becomes prepared to do so.

3.2. Learning from data

Questions concerning learning to work with data are legion: How does one learn to work with data? When is it best to learn to work with data? Is it better to be exposed to it in school? Or wait until working in a practice? Who will teach architects to leverage data to further their designs? Who will assure contractors are up to speed on the multiple ways data informs on the jobsite? The experts I spoke with are all comfortable working with data. How did they get this way? Is it something they were born with? Or something they were exposed to when growing up? Was there something in particular in their education/training/background that prepared them for working in a data-led practice? What, if anything, in their education prepared them for a career working in data and taking an algorithmic approach to the work they do? When did they first realize that they were comfortable working in data? And realize the importance – or potential impact – of working with data? Was one parent an engineer who brought home a computer for you to take apart? What in their education prepared these design professionals for a career in the AECO industry where they are working in data alongside buildings and taking an algorithmic approach to the work that they do?

It is less about learning any one tool than having the confidence and wherewithal to pick up new tools for the task at hand. Where being proficient is no longer sufficient. “The tools are going to change every year,” says David Fano, Managing Director of CASE Inc.

They’re not worried about having to learn a new interface. At my age – I’m in my mid-thirties – I don’t want to get an Android because I don’t want to learn a new interface. The younger kids aren’t like that. They’re not scared they’re going to break it. My generation and up feels like they’re going to break it. The younger generation feels like if they break it they’ll get a new one or they’ll fix it. I’m really excited about that. (Fano, 2014)

Should it be up to schools to implement data – to expose future design and construction professionals to working with data? Is school the right place for this to happen? Or would something be lost? Ringley again:

When I was in school, Michael McInturf, working with Peter Eisenman for a while, then with his own office, was teaching this Maya course. It was insane how popular it was. People would sign-in after the course was capped. You’d have a computer lab full of students, then you’d have two rows of students holding laptops in the back. Because this knowledge was so precious, rare and exciting. Now, I get the sense that people will have this kind of CV checklist. I know 3D printing; I know CNC. I know Grasshopper. It’s not about how amazing those softwares are. It’s, I better fill my CV so I’m eligible for the jobs I want to have. (Ringley, 2014)

3.3. The human component

Our job as educators is not only to transfer information, but to inspire, spur curiosity, talk about possibilities. Working with data does not preclude the latter from happening, whether it is learning to work in robotics, energy modeling, or virtual and augmented reality. Working with data is as much a mindset as it is about the technology. Explains Fano:

We’ve built technology that makes it easier. But it’s really just a mindset. You’ll go to some firms and see some guy tucked away in the corner who keeps a spreadsheet with metrics of every project they’ve ever done. It’s really just a way of thinking. Excel is fine. A notepad would be fine. It’s more thinking of information as this resource that you can go back and reference. Our mindset is very much like, next project, next project, and next project. (Fano, 2014)

What is it about education that leads to this behavior? Fano continues:

School encourages that. How often in design studio do you see a critic tell a student after the first week, you nailed it. Done. That’s counter to the whole idea. I’ve got to tell this kid to do something different. It’s engrained in our thinking. Always do better, always challenge what you’ve done. Our thinking has to shift to what we’ve done is a resource to do better. How many studios in architecture school build on a previous studio? Almost none. You start from scratch. It’s really just a shift in thinking. The tools or technology are whatever. Some will help you do it better than others. (Fano, 2014)

CONCLUSION

Design professionals need to increase their competency at leveraging data to remain competitive, to satisfy their client’s need for evidence, and help make their claims credible. They need to learn how to work with data to verify their intuition and instinctive hunches, and to remain relevant in a business-oriented, STEM-centric world. Educators need to teach buildings as databases, not just as buildings or documents, and discontinue one-off projects: instead, have studios build on previous studios. Additional research on

successfully integrating data-relevant content into the curricula will be needed to help bring this about.

The alternative to learning to work with data in school is to rely on doing so in practice. Here, the onus is either on the firm to assure proper training or hiring staff to address computational design tools from a performance perspective. Alternatively, it is up to the employee to self-train outside of office hours. Again, familiarity with digital tools and technologies serves as a segue to a career where one predominantly works with data. This is becoming increasingly easier for the design professional explains Sean D. Burke of NBBJ:

When I graduated from college, the economy was pretty bad. There weren't a lot of jobs. Eventually, I got a call – someone had recalled I was good at AutoCAD. Soon after getting the job, I put on the hat of CAD manager, tinkering, and writing AutoLISP. Today, with Dynamo, and more modern programming languages like Python, it's making it a lot easier for people to start to adopt new ways of working off of their existing tools without having to recreate everything from scratch. (Burke, 2014)

We as a profession and industry need to start thinking of buildings, and our work as building professionals, in terms of data, and to tell better data stories to our clients and stakeholders. We need educators who recognize the value of data and share this knowledge with their students, the future of the profession and industry. To move forward, we need research focused on defining and identifying problems that can be addressed with data, and a way of thinking about those problems to render them amenable to computational analysis. So is it up to those in higher education to assure that students graduate with the ability to work effectively with data in their building projects? Tyler Goss, Director of Construction Solutions at Case Inc., believes it is. "There is not enough emphasis on the data-centric design approach in education." (Goss, 2014) Architects and educators are encouraged to use adaptable strategies organizations and universities can apply today to make the most of the data they have at their fingertips – much of which many may not be aware of. But it also calls attention to the trend toward a real-time convergence of technologies and processes that aren't reflected in linear first-this-now-this checklists. Forward-thinking research would do well to acknowledge and embrace this trend.

ACKNOWLEDGEMENTS

The quotations in this paper were adopted from interviews that originally took place with the author in 2014. The contributions of these design professionals and educators are gratefully acknowledged.

REFERENCES

- Paul Teicholz, Labor-Productivity Declines in the Construction Industry: Causes and Remedies (Another Look), March 14, 2013. http://www.aecbytes.com/viewpoint/2013/issue_67.html
- Ryan Mullenix, April 30, 2014. *Interview with the author.*
- Robert Yori, July 7, 2014. *Interview with the author.*
- Evelyn Lee, May 1, 2014. *Interview with the author.*
- Brian Ringley, April 6, 2014. *Interview with the author.*
- David Fano, March 10, 2014. *Interview with the author.*
- Sean D Burke, April 25, 2014. *Interview with the author.*
- Tyler Goss, July 28, 2014. *Interview with the author.*

Toward optimization and performance: Assessing architectural design through microcontrollers

Pasquale De Paola¹

¹Louisiana Tech University, Ruston, LA

ABSTRACT: This paper addresses responsiveness and the integration of microprocessors as a real-time assessment tool by investigating the work completed in Responsive Prototyping [RP], a design/craft studio, which was oriented toward the interface of simple interactive prototypes developed to test and assess data relative to the designs produced. Accordingly, and in order to define its pedagogical framework, students were asked to address two focal research/design questions: how do we define the concepts of “responsiveness and optimization” in architecture? And, how do we apply them in specific design studio subsets characterized by a craft component? Within this pedagogical outline, and through the use of parametric interfaces, real-time data was collected, parsed, filtered and used to provide feedback to the project delivery system via the production of responsive architectural prototypes.

KEYWORDS: Responsiveness, Optimization, Microcontrollers, Parametric.

INTRODUCTION

“From the eye to the skin: such is the architectural itinerary proposed here. We tend to think of buildings as forms frozen in the retina or on photographic paper; but architecture appeals as much to touch as to sight. The incursion of energy into that still, crystalline picture defrosts architecture, blurring its hermetic profile and giving it a place in the world of processes and life.” – Luis Fernandez-Galiano (Fernandez-Galliano, 2000; vi)

One of the essential roles of architecture is to create and build structures that holistically and systemically interact with the physical environment. Recent developments and experimentations with microprocessor technologies seem to support a type of architectural production closer to concepts such as adaptability, intelligence, and responsiveness. Yet, while those ideas have been associated to speculative parametric scenarios typically characterized by the excessive use of digi-bio-techno ornamental models, they have hardly been implemented in pedagogical subsets described by the actual physical and prototypical integration of both human and environmental agents (Fox, 2009).

While addressing basic issues of design agency, this paper primarily investigates strategies aimed to build simple interactive prototypes that can provide a preliminary environmental assessment of the design processes via the responsive analysis of the quantitative and qualitative data collected. As another integrative system that assimilates the idea of computing as a design method, interactive prototyping has the potential of becoming one of the main strategies in design research that can be effectively used as a critical and analytical design tool. In fact, the use of microcontrollers can sense the environment by receiving inputs from a variety of sensors, and consequently interact with its surroundings by controlling specific actuators. Certainly, their pedagogical use in architecture can provide to both faculty and students an opportunity to construct and test interactive prototypes in continuous feedback with the designed (Fox, 2009).

Yet, the idea of responsiveness in architectural design is not new territory. In fact, Le Corbusier and Iannis Xenakis' Philips Electronic Company Pavilion at the Brussels Expo of 1958 had been designed as a multimedia interactive architectural installation that integrated visual imagery with sound in order to create a physical and sensorial interaction with its visitors. Corbusier's intention was to “...make an Electronic Poem and a vessel containing light, color, image, rhythm and sound joined together in an organic synthesis” (Lopez, 2011). The Philips Pavilion certainly represented a valid proposal that addressed issues of architectural interaction via responsiveness, and interestingly enough this methodological and ideological framework was successively consolidated by the rise of cybernetic thinking as well as the assimilation of computational strategies applied to architecture both explored by Nicholas Negroponte at MIT. Indeed, those moments represented a true point of departure for what is now a well-established architectural methodology of applied digital technologies (Hensel, 2010).

1.0 TOWARD A PERFORMANCE ORIENTED ARCHITECTURE

“The altered environmental conditions of today can no longer be mastered with the architectural resources of the past...Though architecture today does not fulfill its task, it is nevertheless the only decidedly peaceful profession in which synthetic thinking can be exercised on a large project without hindrance... The relationship between biology and building is now in need of clarification due to real and practical exigencies. The problem of environment has never before been such a threat to existence. In effect, it is a biological problem.” – Frei Otto (Otto, 1971; 7)

Certainly, computational and synthetic design thinking has allowed us to investigate and address some of the issues originally recognized by Frei Otto in 1971, creating a new sense of interdisciplinary, which seems to be finalized toward the creation of responsive interfaces. In fact, rather than generating a process dictated by its mere technological and technical delivery (mostly software based), computational approaches put the emphasis on the systemic and dynamic relationship between parts (Hensel, 2013). They also address research and experimentation by generating creative explorations that operate within a virtual environment controlled by algorithmic definitions. As a highly systemic methodology, computation is a technique that is symbiotically integrated with design; it is not about form, but it focuses on data driven processes that can lead to a particular mathematically controlled form. This brings up the idea of “context-derived data” that has to be understood both quantitatively and qualitatively. Yet, as in any algorithmic process, the data collected has to be filtered through specific rules open only to one specific interpretation (if...then). It is a machinic process that uses quantitative data to generate a framework characterized by elements in constant feedback to one another as well as with external stimuli (Hensel, 2010). This seemingly intelligent/responsive framework is certainly defined by spatial conditions, which use algorithms to enhance and control its overall performance revealing what criteria are met and how buildings function. Yet, before addressing the idiosyncrasies of such a methodology and its intrinsic pedagogical subsets, I believe that it is appropriate to delineate and understand the concept of performance, and the role of active agents, human and non-human.

“The environment must be organized so that its own regeneration and reconstruction does not constantly disrupt its performance.” – Christopher Alexander (Alexander, 1964; 3)

While Alexander’s proposition is relevant toward an understanding of the dynamic relationships existing between morpho-tectonic conditions and performance, it does not quantify nor qualify parameters and benchmarks that may define the level of disruption within the system. Those elements have to be quantified numerically and mathematically so that a specific value can be assigned in order to define performance-based standards. However, while the idea of performance can be addressed both formally and analytically via the integration of particular software-based interfaces such as Rhino 3D, what becomes crucial is the recognition of those “active external” agents that have the potential to disrupt or facilitate particular performative outcomes. Andrew Pickering, a sociologist, philosopher and historian of science stated that:

“One can start from the idea that the world is filled not, in the first instance with facts and observations, but with agency. The world, I want to say, is continually doing things, things that bear upon us not as observation statements upon disembodied intellects but as forces upon material beings. Think of the weather. Winds, storms, droughts, floods, heat and cold – all of these engage with our bodies as well as our minds ... Much of everyday life, I would say, has this character of coping with material agency, agency that comes at us from outside the human realm and that cannot be reduced to anything within that realm.” – Andrew Pickering (Pickering 1995, 6-7)

It is clear that architecture in its physical representation needs to be understood as a systemic, spatial and material organization in constant interaction with external agents where its morphological condition is always controlled by contextual forces, which can be characterized by incredible heterogeneity. Thus, performance-oriented strategies have to address the uncertainty and variability of active external agents, which can only be controlled via complex parametric techniques so that form, or the idea of it, follows the data contextually collected. Within this framework, it is important to orient our discipline toward a new methodological and pedagogical model that more accurately takes into consideration shifts in computational production, especially as they relate to issues of interconnection and intelligent adaptation (Tedeschi, 2014). This can only happen if our understating of performance and optimization is not statically defined by checklists or tables, but it is derived by evolving external environmental parameters that can only be collected by using real-time feedback technologies. Architectural production in an age defined by computational design thinking must arrive at approaches that address transforming systems and bio-systemic interaction.

2.0 PEDAGOGICAL SUBSET: RESPONSIVE PROTOTYPING

“It becomes possible to coordinate the operation of different systems to achieve significant efficiencies and sustainability benefits. In designing smart products, buildings, and urban systems we simultaneously consider both their synchronic and diachronic aspects.” – Bill Mitchell (Kemp, 2000; 5)

In order to address and investigate both concepts of prototyping/fabrication and design agency, the pedagogical module Responsive Prototyping [RP] proposed a mediated pedagogical praxis based on the integration and use of 3D softwares such as Rhino/Grasshopper with microcontrollers, sensors, and actuators to provide students an understanding and ability to design, develop and test interactive architectural ideas in an environment characterized by heterogeneity. The course was organized around two major research questions: how do we define the concepts of “responsiveness and optimization” in architecture? And, how do we materially and tectonically apply the same conceptual frameworks in specific design studios characterized by a craft component?

Therefore, and to frame the domain and content defined by of the first question, students were asked to research specific case studies that addressed issues of architectural fabrication, responsiveness and optimization via the use of microcontroller devices capable of collecting real time data to outline specific external benchmarks. Students were also introduced, via weekly seminars, to basic concepts of electronics as well as to specific technological tools used to understand issues related to the use of microcontrollers,

physical computing, scripting, and debugging to collect, monitor, and control the data recorded in Rhino/Grasshopper via Firefly. Firefly is "a set of comprehensive software tools dedicated to bridging the gap between Grasshopper - a free plug-in for Rhino - microcontrollers and other input/output devices like web cams, mobile phones, game controllers and more. It allows near real-time data flow between the digital and physical worlds – enabling the possibility to explore virtual and physical prototypes with unprecedented fluidity." Essentially, it enables users to graphically manipulate the data recorded by a microcontroller device so that the same data can be used to generate 3D interactive objects or devices.

Microcontrollers (Figure 1) are essentially small computers that contains processors and pin connections with input/output functions and various sensors that can interact with the physical world so that the objects designed can sense and respond to touch, position, sound, heat, and light. Because of its relative affordability and open-source nature, Responsive Prototyping studio used the Arduino Uno, a microcontroller system based on the ATmega series of chips, which allows it to be programmed via a serial connection such as a USB (Margolis, 2011). While they are designed to be relatively easy to use for people that have little to no electronic experience, its interface is primarily controlled via codes and scripts that require a basic understanding of Processing and C or C++ language.

The first step required the students to identify what they wanted to measure (light, sound, movements, humidity, etc.). Consequently, they had to get the specific sensor connected to the Arduino, upload the Processing code relative to the sensor used to make the measurements automatically. With this setup, the microcontroller provided real-time data measurements every 100 milliseconds printing the values onto the screen. Data was then copied and pasted in the row of values into Excel eventually creating line graphs needed to assess optimal benchmarks based on specific regional data sets analysis. In order to bridge the gap between the digital and the physical, Grasshopper and Firefly were used to create interactive digital environments by connecting set of components such as light sensor, LED or servos motors (servos have integrated gears and a shaft that can be precisely controlled by the microprocessor).



Figure 1: Arduino Uno Microprocessor with Sensors Kit. Source: Arduino.com

Based on the generative application of parametric design and various scripting techniques, Responsive Prototyping [RP] also explored the integrative use of parametric modeling to generate differentiated geometrical and formal solutions derived from external agents and other heterogeneous parameters (Tedeschi, 2014). This methodology allowed for a better understanding of incremental values related to both environmental and morphological relationships in a way that the students could eventually craft and activate the interdependencies between new forms in an iterative, indeterminate, complex, continuously evolving process. Indeed, computational models promoted complex interrelations between form, material, structure, space and their systems' behavior and performance (Hensel, 2010). The scripted and parametrically defined surface structures were constituted of material and aesthetic performativity and were all controlled in Rhino 3D. Most importantly, this pedagogical framework ended up generating work that questioned, via the interpolation of large subsets of data, the relationship between form and space, and between the envelope and the content.

3.0 RESPONSIVE INTERFACES

In order to explore and investigate different strategies characterized by the use of interactive and responsive prototypes applied to particular design frameworks, students had to individually explore both fabrication and computational issues. While the two projects analyzed in this paper looked at recording and collecting traditional data values relative to motion and light intensity, their conceptual design articulation ended up

being primarily based on experiential elements of human interaction (not necessary quantifiable qualitatively speaking), creating prototypical architectural installations that would respond to the interior environment while also creating a unique “phenomenological” experience for its occupants.

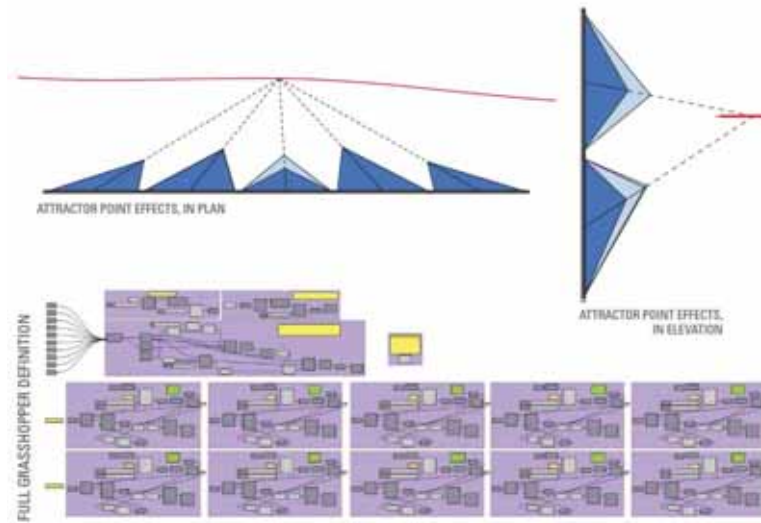

Figure 2: Reactive Architecture by Chis McLean. Source: (De Paola 2013)

Reactive Architecture (Figure 2) aimed to challenge the idea that buildings are, once built, entirely immobile and unchangeable entities in our environment that provide little to no interaction with their users. Though primarily a consequence of technology and economy (that is, the capability to change and the ability to afford it), the project analyzed the lack of meaningful alteration in our environments, which tends to produce an experience that, over time, becomes increasingly jaded. Installations and buildings that address the issue of immobility are normally unable to produce a meaningful change in the interactions they provide. They typically rely upon entirely passive methods (e.g. solar activity at Jean Nouvel’s Arab Institute), counting upon the (unreliable) actions of people to drive their actions. Even if successful, passive experiences still become jaded over time. Particularly, Reactive Architecture proposed the design of an architectural component, a wall panel, that is active and sourced specifically to the individual that uses it and that must be adaptable, such that alterations in its environment, and in the persons experiencing it in visible and variable ways.

In order to sense and measure movement, two motion sensors that detect distance were connected with the Arduino: an infrared proximity sensor and an ultrasonic range finder. Those two output components essentially sense any sort of movements and communicate numerical data back to the microcontrollers; the same data can be evaluated in Firefly via particular data components that analyze its hierarchical nature by using tree-chart components. Additionally, an infrared proximity sensor was also used to indicate the distance of interaction with the reactive surface. In fact, the sensor has both a light source (visual indicator) and a sensor; the light source bounces infrared light off objects and back to the sensor, and the time it takes the light to return is measured to indicate how far away an object is. An ultrasonic range finder fires out high frequency sound waves and listens for an echo when they hit a solid surface. By measuring the time that it takes a signal to bounce back, the ultrasonic range finder can determine the distance travelled and communicate that to the architectural prototype designed, which in return responds to the users (Margolis, 2011; 65). Rather than rely upon the initiative and curiosity of random passers-by, Reactive Architecture reaches out and engage its surroundings actively and aggressively. The design created a flexible architectural skin that stretched around areas that recorded a high presence of social gathering/motion. Additionally, low voltage LED lighting was also used to map movement in order to provide a “graphic and visual” representation of the levels of active interaction. Designed after Studio Luz’s Diva Lounge, Reactive Architecture essentially emphasized the idea that architecture could and should create opportunities for social interactions while also recording and possibly promoting a desired mood.

The Wave Wall (Figure 3) is a responsive façade that functions to provide an optimal set amount of daylight into a building located in very harsh sunlight conditions. In order to define the initial architectural and technological domain, the student analyzed the responsive facade system of Al Bahar Towers in Abu Dhabi where temperatures are steadily above 100 degrees Fahrenheit. These towers, while conventionally and programmatically organized, are shaded by a secondary lattice device that opens and closes in response to sun exposure. Thus, in order to similarly sense light and measure its intensity, the student developed a

closed circuit system in which an Arduino microprocessor was connected to a photocell and a light dependent resistor called LDR (Light Dependent Resistor). This output component essentially acts just like a resistor while its resistance changes in response to how much light is collected by the photocell. In order to convert the values collected in Grasshopper via Firefly, a fixed resistor was also connected to the Arduino board to translate the analog numbers into a voltage. Thus, to design the mechanical apparatus that measured and translated the same data into a responsive device, the student had to put together a microcontroller unit based also on a 10K resistor, a breadboard, 3-4 wires used to connect the breadboard to the Arduino Uno, and a USB cable to upload a code for serial communication of external data. One of the major issues with this setup was based on the complexity of the script needed. In fact, the student had to measure both minimum and maximum range of light intensity from the photosensor and consequently map values that were either too high or too low. In order to keep the range consistent, Processing scripting was used to determine the true numerical range (average value), allowing the sensor and the Arduino to discard values not included in the same range.

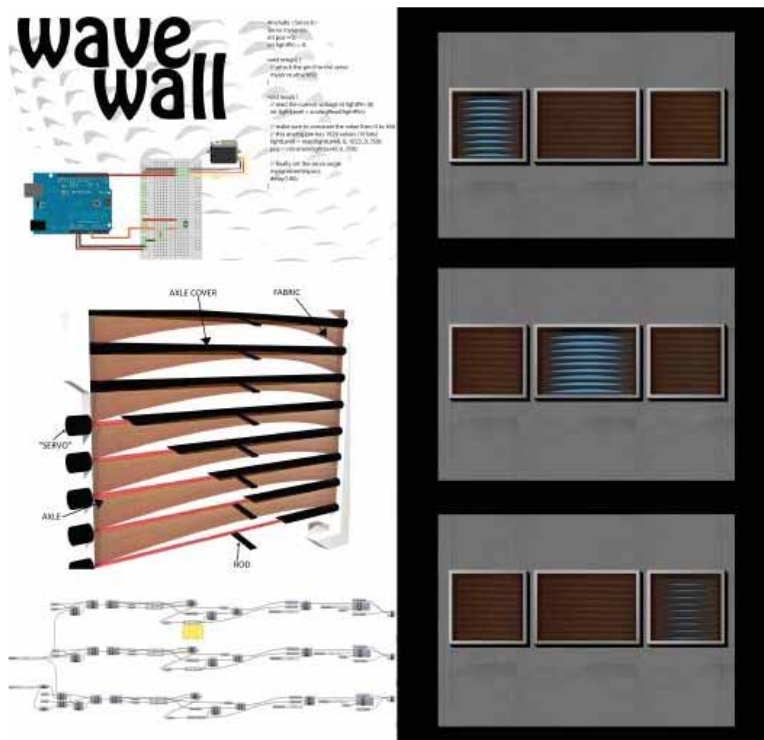

Figure 3: Wave-Wall by Will Doss. Source: (De Paola, 2013)

Again, the Arduino board uses a USB cable to send serial communication to and from a computer. When data from the Arduino is printed to the serial port via a Generic Serial Read component, Grasshopper and Firefly open the connection and read the data into a buffer and communicate it back to Grasshopper and Rhino. The Generic Serial Read component essentially returns any data being sent over the serial port. As explained before, Arduino components are specifically tailored for using Firefly Firmata outputs, which are basically sets of instructions loaded onto the board that tell all of the pins how to exchange data with Grasshopper. The data collected was then used to develop a different script that would communicate inputs and outputs to a servo motor, which basically handled the high torque rotation of the device designed to respond to light intensity. Servos are essentially small voltage motors that have an integrated gear system and shaft that can be controlled via scripting on a variance of 0 to 180 degrees. Thus, based on user-defined variables typical of particular regional comfort levels (North Louisiana in this case), the responsive prototype would open and close individual flaps to permit or deny light or potentially respond to the ambient temperature inside the building. This responsive façade was designed via integration of both microprocessors and light sensors in order to track sunlight, shading the interior spaces and also preserve views of the outdoors. Again, sensor data was collected and stored via Arduino and Firefly, and it was then processed and interpreted according to the various modes of behavior explored in Rhino/Grasshopper.

CONCLUSION

“This makes it clear that a synergetic understanding and approach is required to unlock these complex interactions for the purpose of an instrumental approach to architectural design. It is evident that the articulation of architectures and the built environment can absorb and satisfy multi-functional and aesthetic criteria and preferences and that partitioning of space and modulation of environment are both consequences of material practice.” – Michael Hensel (Hensel, 2010; 55)

In his book *Performance-Oriented Architecture*, Michael Hensel states that architecture, environment and inhabitants all perform and interact in relation to a particular active agency, which can consequently define certain morphogenetic qualities of the architectural artifacts itself (Hensel, 2013). Thus, this paper investigated strategies aimed to build simple interactive prototypes through the use of small microcontrollers to verify and test the idea of external agency and its effects on the design of small architectural prototypes. In order to effectively investigate issues of design agency, students had to develop additional technical skills like scripting and parametric modeling via plug-ins like Grasshopper and Firefly to generate viable digital and physical solution that showed different levels of adaptability and responsiveness. Conceptually speaking, computational design strategies, understood as systemic and methodological paradigms, provided a framework of complexity that linked form, function and structure and that also allowed for all of them to morphologically respond to external stimuli. Interestingly enough, the vast majority of those algorithmic models look at the self-referential organizational complexity of bio-analogues systems, whose form adaptation appears to be in constant feedback with external agents.

Yet, when we look at current pedagogical models based on computational strategies, formal analysis seems to be more important than optimization and performance. Thanks to current advancements in digital and microcontroller technologies, we have now the ability to design and create interactive environments responsive to active agents. The projects undertaken in Responsive Prototyping [RP], while characterized by a perhaps simplistic and repetitive tectonic and performative agenda are particularly important because they represent a step toward a pedagogy more open to responsiveness while addressing heterogeneity and external instabilities. Thanks to technology, architecture's ideological and conceptual playground has noticeably changed; it is now time to investigate systemic heterogeneity and performance-oriented approaches where buildings are actually “doing something” rather than merely representing it.

REFERENCES

- Alexander, Christopher. 1964. *Notes on the Synthesis of Form*. Cambridge, MA: Harvard University Press.
- Burry, Mark. 2011. *Scripting Cultures*. Chichester, UK: John Wiley & Sons.
- Fernandez-Galiano, Luis. 2000. *Fire and Memory: On Architecture and Energy*. Cambridge, MA: The MIT Press.
- Fox, Michael. 2009. *Interactive Architecture*. New York, NY: Princeton Architectural Press.
- Hensel, Michael. 2010. *Emergent Technologies and Design*. New York, NY: Routledge.
- Hensel, Michael. 2013. *Performance Oriented Architecture*. Chichester, UK: John Wiley & Sons.
- Johnson, Greg. 2010. “Architectronics: Toward a Responsive Environment,” *IJAC, issue 1, volume 09*.
- Lopez, Oscar. “AD Classics: Expo '58 + Phillips Pavilion / Le Corbusier and Iannis Xenakis” 25 Aug 2011. *Arch Daily*. Accessed 04 Dec 2014. <<http://www.archdaily.com/?p=157658>>
- Margolis, Michael. 2011. *Arduino Cookbook*. Cambridge, UK: O'Reilly.
- Menges, Achim. 2011. *Computational Design Thinking*. Chichester, UK: John Wiley & Sons.
- Otto, Frei. 1971. *Biology and Building Part 1*. Stuttgart: University of Stuttgart.
- Peters, Brady | Peters, Terri. 2013. *Inside Smartgeometry*. Chichester, UK: John Wiley & Son.
- Pickering, Andrew. 1995. *The Mangle of Practice: Time, Agency and Science*. Chicago: University of Chicago Press.
- Tedeschi, Arturo. 2014. *AAD_Algorithms-Aided Design*. Potenza, Italy: Le Penseur Publisher.

Wicked tactics - UX/XD: World-building in post-virtual space

Heather Renee Barker¹

¹California State University, Long Beach, California

ABSTRACT: Wicked Tactics – UX/XD explores and describes strategies for design in a post-virtual world. Wicked - as in wicked complexity, tactics as actions that cross strategic fields to create stunning solutions and User eXperience / eXperience Design (UX/XD) as a user-driven design methodology assuming humans interface everywhere. As the semantic web parses meaning from the big data of the internet of everything, designers explore affinities between social/philosophical and mathematical/programming expressions to move beyond stylistic parametric expressions to meaningful parametric expressions.

“Every age has its own ideas; it must have also words adapted to those ideas.” –Victor Hugo

We have a disconnect. New technologies have created a new age with its own ideas. Contemporary design terminology must be adapted to those ideas (semantic shift). Ultimately, the goal is to develop a common language - shared by makers of objects, spaces, and means of communication: a language of our contemporary condition. This work takes up the cause to reframe the language and processes of design in order to develop new strategies and to generate novel solutions.

In the post-virtual world, we reside in seamless space where the tactics and strategies for designing human-computer interface are based on *human experience*. You are likely interfacing with the digital realm right now; thus, a part of your body-based consciousness is concurrently residing in the shared space of the internet. This phenomenon is creating a new human: the Internet of Me (IoMe). Designers of space are expected to provide solutions for the distributed experiences of new humans in post-virtual space. These solutions require building worlds before designing buildings. Architectures must become epigenetic/control spaces satisfying the spatial, functional and experiential needs of a post-virtual society.

KEYWORDS: Parametric Modeling, Design Strategy, Social Media, UX/XD, World-Building

INTRODUCTION

This is a theory addressing design processes adapting to a new context. This work will:

1. define and describe the changed context,
2. search for language and procedural affinities across the spatial divide and
3. derive processes and methods from that context to generate novel solutions conditioned to our time.

Why is it relevant? *This work intends to redefine architecture in form and scope, in material and purpose.*

This theory assumes human perception is augmented through technology and human presence resides in a seamless physical/virtual space of experience. Creating new design processes will continue to challenge the makers of space to recognize architecture as a complex adaptive system. Beyond designing a physical space to support technology for virtual communication and experience, we must design architectures as interactive solution spaces of human, physical and virtual agents – to serve the needs of new humans in post-virtual space.

1.0 WICKEDNESS

1.1. Wicked complexity in social space

The rules have changed. Architectural practice is experiencing a radical shift. The building types of architecture (as a functional definition) no longer exist. We now learn in hospitals, heal in hotels, vacation while doing scientific research, teach while on vacation, socialize while working and work just about everywhere. Designing spaces is designing for massive unknown variables. The technologies that have enabled an *Internet of Everything (IoE)*, including buildings, objects and humans, have also caused a fundamental rupture in the system of designing and constructing environments. New systems, tools and languages suited to IoE are developing at a rapid pace and introducing new levels of complexity heretofore unheard of. *In the Internet of Everything, those same systems, tools and languages inevitably become part*

of architecture. Now and in the future, beyond creating buildings that satisfy firmness, commodity, and delight, architects (and others) will engage in *world-building*. Once a term of sci-fi, fantasy or game space; the boundaries between virtual and real space have dissolved and we operate in a seamless, post-virtual space for which world-building is well suited. Architectures are now expected to create a context to develop a narrative, to embrace complexity and interactivity and to be co-authored and revised during the process of construction. Post-virtual architectures are conceived and constructed to offer spaces of experience, communication, collaboration, entertainment, learning and commerce.

The complexities inherent to designing/planning for social spaces have been defined as 'wicked' (Rittel, Webber). The fundamental difficulties in designing solutions for such complexity are well-described in their *Dilemmas in General Theory of Planning*. In that work, the authors clearly delineate the need for new methods to approach wicked complex issues. Wicked problems demonstrate both causalities and objectives that are ill-defined and interrelated. Wicked problems are a complex field of open and interactive systems where *no definitive statement of the problem is possible* and the process of collecting information to define it depends on the approach one intends to take to solve the problem. "Wicked problems have no stopping rule" (Rittel, Webber) and therefore any solution is assumed to be iterative: re-defined and re-applied until the context changes to the point when a new wicked problem emerges. Simply asking a question acts as an agitator in a field of noise that will then demonstrate emergent properties. Therefore, approaches to wicked problems must also be non-teleological, interconnected and aware that every intervention is absorbed by, leaves a mark on, and becomes part of the wickedness. Fortunately, there are models for reconciling such complexity and emergence.

1.2. Wicked complexity in post-virtual social space

In the post-virtual world we have crossed the threshold into seamless space. New humans spend the majority of the day with part of their body-based consciousness concurrently residing the shared space of the internet (Wolf) (Pew). This phenomenon is creating a new human: the Internet of Me *IoMe* (Barker). As humans, we define ourselves through our experiences and our knowledge. Experiences can be customized; therefore, designing the experience is designing the person. In 'world-building', we not only design places, we design behaviors. In a successful 'world', systems, forms, rules and rewards are all accounted for: allowing the agents to become the objects and the known to become the knowing. It is a living system.

1.3. Managing wickedness

There are structures and models for managing vast amounts of complex, undefined data with multiple unknown variables; examples can be found in linguistics, programming and mathematics. In order to discover analogous models that may be applied to the design process, we look for similarities in intent and method.

It is essential to engage in deep and detailed research in order to establish a rich and nuanced field of relevant information for any design project. The first challenge is to model all relevant information into a data field. An important assumption is that all information considered relevant to populate a given system-model is somehow related. The degree to which the information is related will define the density of the model and the complexity of the structure of that model. That field of information must be modelled as a *declarative representation* - where the model is initially independent of the tactics and analysis to be applied to it.

The wickedness of the information suggests representing a new type of space beyond 3, 4(time), or even 5(virtual) dimensions. The notion of a space containing more points than 'normal' space begs the question, could new wicked spaces be discovered? *Projective space* and *Riemann surfaces* provide mathematical models that may provide strategies for representing such an information model.

Once the field of wicked information is established, *discovery algorithms* (used to parse the vast amounts of unstructured information in order to identify patterns in Big Data) could be applied. Applying the same algorithms, to a declarative representation of all the information pertaining to a given design project, could reveal patterns to inform novel design strategies for spaces of massive unknown variables.

2.0 IoME HUMANS

2.1. Internet of me and augmented cognitive processes

The terms *digital self* and *quantified self* are frequently used to describe the contemporary phenomenon of individuals, augmented through technology, evaluating and sharing personal and biometric data to achieve desired outcomes. Tools to monitor bodily conditions such as heart rate, sleep patterns, physical activity, and stress levels are synthesized with the tools to monitor social conditions such as popularity, perceptions, opinions, and mood. The monitoring is physically untethered, yet constantly connected to the internet of things and social media. *We have developed into an Internet of Me*. The immediacy and availability of the data collected about the self has changed basic human behaviors and the fundamental awareness of the self as it relates to society.

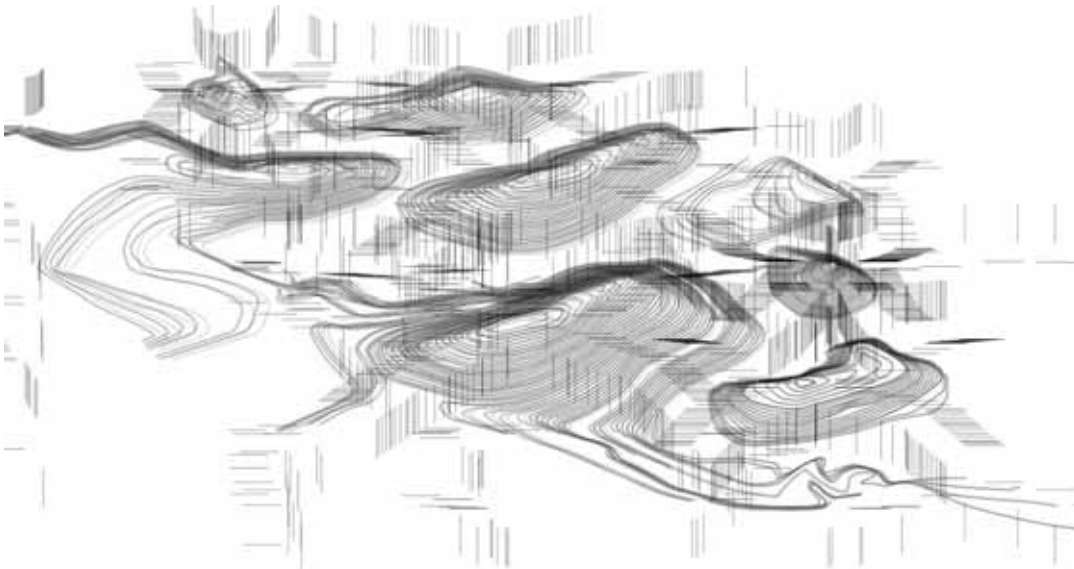

Figure 1: Wicked Data-Space Modelling. Source: (Author 2015)

2.2. At home in post-virtual superspaces

In the post-virtual world we have crossed the threshold into seamless space. Within this space, tactics, technologies and strategies have developed to optimize the human-computer interface. The success of those interfaces is measured on a scale of *user experience* – perceptions and behaviors.

The data of our quantified selves and our interactions in post-virtual superspaces can be interconnected and cross-referenced. As technology is grafted to our bodies, it is also grafted into our offices, hospitals, schools and homes. Advances in technology have allowed for the dematerialization of the interface device; integral and indistinguishable from body and space. Therefore, at home in our virtual superspaces, the data from our bodies, behaviors and environments is a dynamic part of the internet of everything. Where then, do our architectures begin and where do they end; and how do you define the scope of a project?

2.3. New humans and new behaviors

New technologies of monitoring, communication, data-gathering and analysis effectively allow humans to 'outsource' a large portion of their cognitive, behavioral and functional activities. Various applications maintain personal contacts, organize meetings and events, quickly share information with a group, analyze finances, monitor activity, communicate with clients and provide remote access to our colleagues, tools and data. This outsourcing is also known as *agency* and many apps have become agents – acting on our behalf in efforts to improve productivity or increase time for leisure (Pieper). Many of these activities previously took place and were facilitated through buildings. As the boundary between the data space and the physical space becomes imperceptible, architecture must be redesigned to act on behalf of loMe humans. Can we create an architecture of agency?

Another behavioral change in the loMe humans is *community building*. Communities are created according to elective affinities, especially when there is no hurdle to direct communication. The nature of 'place' has completely changed and our experience of space is radically altered. Our senses and awareness exist simultaneously in various places – literally. We have a sense of expanded perception and we engage in behaviors at one location that have been instigated in another. New architectures will need to be developed to house communities and accommodate remotely solicited behaviors. The role of architecture is no longer just to house, but also to facilitate distributed behaviors: a post-virtual space to pass through in order to support the creation of communities.

3.0 UNRECONCILED LANGUAGE AND INFINITE SEMIOSIS

3.1. Language in programming, languages of meaning

Computer science is deeply engaged with parsing the unprecedented amount of information generated as big data in the *internet of everything*. Designers, searching for a design methodology in this new era, explore affinities between social/philosophical and mathematical/programming expressions in order to discover appropriate strategies and generate new meanings. The shared tools of programming and parametric modelling afford opportunities to visualize and distinguish patterns that were previously undiscoverable. Through a re-alignment of vocabularies, a parity of meaning can be achieved. This enables architecture to

move beyond stylistic, parametric expressions of form, to meaningful parametric expressions of interactions and behaviors. Opportunities are revealed *through the process* of resolving the language disparity as the synchronization of technological semantics and social semantics transpires. Ultimately, the goal is to develop a common language - shared by makers of objects, spaces, and means of communication: a linguistic/mathematical language of our contemporary condition. To create seamless spaces that elicit experiences and facilitate behaviors, design must resolve philosophical concepts with affinities in mathematical expressions. An example of such would be Barthes' *structural analysis of narratives* and the meaning parsing algorithms of *latent semantic indexing*. Although these two thought models come from the apparently disparate areas of philosophy and computer programming, they share clear thought affinities and could, if integrated to inform structure and meaning, become the basis for new methods and tactics of design. There are numerous other cross-disciplinary affinities, the descriptions of which exceed the scope of this document.

4.0 UX/XD - METHODOLOGY AND TACTICS

4.1. User eXperience / eXperience Design

As terminology that has evolved from human-computer interaction (HCI), UX/XD is the human-centered focus of design to improve the interactive experience. The growing field of experience design includes computer programming, event design, interaction design, marketing and architecture. UX/XD is a *scenario-based process* that includes human perception, psychology, behavior and involves higher-level information assimilation skills. Anthropocentric approaches to design are a phenomenon of the Enlightenment and the view of man and man's reason as dominant in a constant and unfeeling natural world. Now, it is widely recognized that design for the body, based on ergonomics, must expand to include and recognize the primacy of the psychological experience of self - which includes bodily as well as other perceptions.

A UX/XD process is grounded in research and looks to identify unmet needs through a deep and detailed analysis of a user group. A scenario, usually developed as a visually enhanced narrative, develops a comprehensive data field for the user context – rich in sensory and empirical information, interdependent in space and time. The process is an empathetic analytical process and asks *why* as often as it asks *how*. For example, *why/how* does a user enter a building, *why/how* can a user feel comfortable in a space, *why/how* can the function of a development be determined to be efficient. The “whys” ask questions of culture, psychology, economics and perception. The “whys” are where to find meaning, opportunity – and value.



Figure 2: Tactics across fields to create new strategic space. Source: (Author 2015)

4.2. Wicked tactics and strategic spaces

Once a wicked and plastic information space is established, clear methods for navigating that space to achieve desirable ends must be established. Tactics are behaviors conceived to achieve goals in an unknown future and place. UX/XD methods address behaviors, needs and interfaces of new humans living in a post-virtual world with the intent of developing a strategic space.

A tactic is a calculated action determined by the absence of a proper locus [and] the space of a tactic is the space of the other. [A tactic is deployed] on and with a terrain imposed on it and organized by the law of a foreign power. [One who deploys a tactic] must vigilantly make use of the cracks that particular conjunctions open in the surveillance of the proprietary powers. It poaches them. It creates surprises in them (de Certeau 36-37).

Strategies and Tactics differ in key aspects: Strategies create their own space but tactics are conceived outside of an established space with the intent to find opportunities in the un-resolved areas of any system (deCerteau).

Employing tactics is consistent with the initial distinction between the declarative representation of the information field and the methods for interpreting and navigating that field. Tactics are disruptors that can cross strategic fields to generate novel solutions. New tactical models generate new strategic spaces and new worlds. Resulting strategic fields and narrative spaces are bound in a 'world'. Architecture is now called upon to build such complex worlds.

Wicked tactics look for opportunities in the vast complexities of a strategic field, and may act deliberately outside the strategic space, relying on the *butterfly effect* and interrelatedness of the system to achieve desired behaviors. These tactics build strategies that are agile enough to *design for adaptive agency* in an *interactivist, multi-agent system*.

5.0 ARCHITECTURES – BIGGER THAN BUILDINGS

5.1. Experience field and epigenetic spaces

Architectural solutions should be conceived to include the entire experience field of the user: redefined in form, scope, material and purpose. Instead of 'creating' or 'constructing' space; the process of *creating* architectures has taken a performative and semantic shift. Architects should now focus on *conditioning space to achieve behaviors*. Conditioning assumes non-teleological strategies, a gentle and responsive engagement with the environment and the user to design for emergence (Berger).

Designing for emergence includes anticipating change in the range of bodily and non-bodily perceptions within post-virtual space. Architectures are now expected to create an interactive, adaptive context to facilitate behaviors and experiences. In the mathematical field of topology, models have been developed to define continuous relationships between topological spaces that maintain all the topological properties of a given space. We can begin here to develop models of continuous spaces of experience. This is architecture without boundaries. Designing buildings is only part of the task. Architects must design environments: epigenetic control spaces of artifacts and agents for IoMe humans.

5.2. Tools of design

Design assumes purpose. New tools and new materials can create purpose. Architecture has always valued *material knowing*: a belief that a material should be "what it wants to be" depending on its inherent properties, the tools available to manipulate it and the cognitive capabilities to challenge expectations and cultural norms. Post-virtual design embraces materiality and precision enhanced by include human haptic, psychological and environmental perceptions.

When synthesized, parametric and BIM tools along with new fabrication processes and UX/XD methods provide a comprehensive tool-set for designing architectures of seamless space. We have developed proficiency with our digital tools; but what about the tools of meaning? What is the role of material and the body and how does proprioception work in plastic space? Does that sense of the body (presence) in space affect meaning? It is time to revisit and adapt human-centric design processes based on perceptions and experiences of new humans, augmented by the digital and material precision of new technologies.

6.0 PARAMETRICS OF MEANING

6.1. Meaning through narrative and form

A thing is meaningful to you if you have a stake in it – and meaning is closely tied to value. Meaningful architectures are valuable architectures. Meaning is created through experiences, relationships and behaviors. The communication of meaning is done through narratives: oral, written, visual and kinesic. Therefore, narrative and meaning are inter-related. Narratives have structures or formalisms that facilitate

communication and meaning. *Finding the right formalism to communicate a desired meaning is essential to create meaningful architectures.* In order to design for meaning, the design process must also integrate epistemological and ontological questions into the research and scenario building process. The study of the nature of meaning and knowledge as well as fundamental questions of being and reality take on new relevance in the act of creating meaningful and valuable space.

Much architectural discourse has been centered around form and meaning with a range of perspectives on the primacy of one over the other. The forms of the artifacts of our environment (architecture) get built in to our experiences and narratives, and are assigned meaning; regardless of the intent (or lack of intent) of the creator. Many designers willingly ascribe the task of the creation of meaning to context and chance. As ever more architecture is conceived through parametric design tools, the chasm between the human needs and digital space must be bridged to create meaning and valuable architectures. The result of disregarding meaning in the design process is that parametrically generated forms become purely stylistic and will not retain value or become relevant artifacts of culture.

6.2. Chasm between digital tools and the creation of meaningful architectures

Fundamental to creating an artificial intelligence (AI), is creating a language of *knowledge representation*. Such languages are structured according to human reasoning and allow for the structuring of vast amounts of data. As creators of architectures, developing parametric processes to generate form is also a kind of knowledge representation. Bits of code are created to direct the behavior of forms according to predetermined properties and processes. Models of code and mathematics based on processes associated with the creation of meaning can be built into the parametric process of architectural design. Often though, parametric design occurs without narrative intent or a world-building objective. This had led us to the current state of *parametric as a style* and form for form's sake. There is a beauty of novelty and precision but these architectures often leave a deep void of emptiness of meaning. In the best cases, these buildings may demonstrate a mastery of the tools and materials of design. A demonstration of a virtuosity of parametric architecture remains unachieved. Virtuosity assumes proficiency of skill, yet also requires the ability to elicit complex emotional responses. Virtuosity assumes a design for interaction and affect.

In post-virtual space, it is necessary to design within the feedback/feed-forward loop of *interaction theory* (Gallahger). Human experiences and behaviors can now be reciprocally modelled based on mathematical processes. The intent is to bring those more meaningful processes into parametric design. Again we look to mathematics and programming for models to deal with the complexities of design the post-virtual space. We see promising examples in algorithm design, such as *semantic evaluation* (translating intuition to computer language), *stochastic processes* (sets of random variables that behave indeterminately over time) and *soft-systems methodology* (a framework to deal with wickedly complex problems). Additionally, *forward compatibility architectures* that design for future input and change like multi-paradigm *extensible semantic languages* (that enable elegant expansion to allow for changes in the problem question) and *fuzzy sets* (that define variable relations amongst individuals) analogous to Gallagher's interaction theory.

WORLD-BUILDING WITH SOFT-SYSTEMS METHODOLOGY

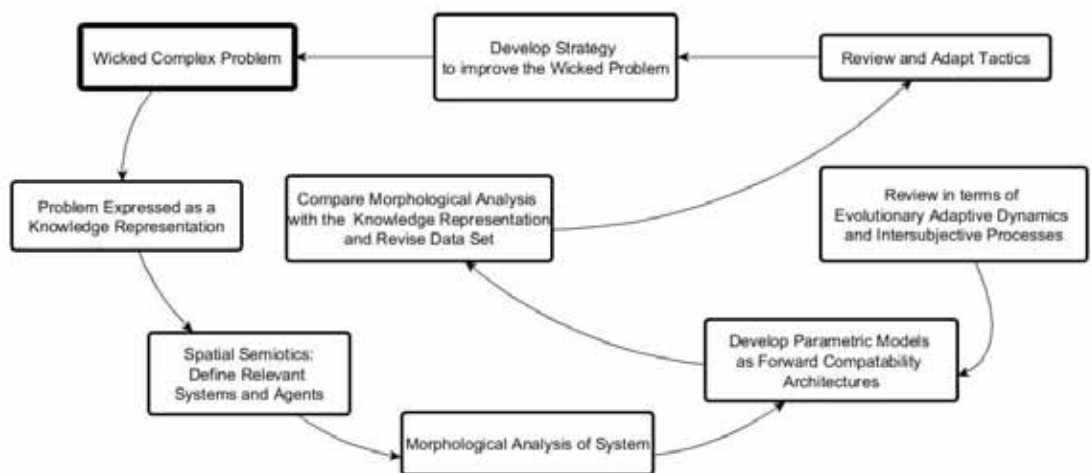

Figure 3 : Process for designing a complex adaptive system. Source: (Author 2015)

7.0 RESULTS/APPLICATIONS

7.1. New methods and tactics

This work has identified a selection of non-teleological, new methods and tactics for design of post-virtual architectures. Selecting and combining the appropriate tactics will depend on the nature and wickedness of the field to which they are to be applied. Linking *situational semantics* (Barwise, Seligman) (Kratzer) structuring possibilities, *spatial semiotics* (Osgood) establishing the symbolic meanings of and in space and *Kansai engineering* (bringing emotion to objects and technology) could be an example of setting a tactical field to develop a strategic space. This tactical approach will generate a strategic space to create an architecture in terms of meaning, personal and social context, aesthetics, haptics, performance, human perception, value, technology and performance.

7.2. Redefining architecture(s)

As material and immaterial architectures are synthesized and built, the digital precision of computer science and parametric modelling and the hyper-biological perceptive sensory apparatus are acting concurrently - creating meaningful spaces in time. A new direction in *architecture* is taken. Spaces are designed to interact and adapt in time and for a variety of uses while sharing information with and creating information for the data space. Within these superspaces, meaning is constantly created based on the experiences of the users and becoming part of the collective data consciousness. The design of these spaces is non-teleological and it requires great skill to deliver a performative solution. Post-Virtual Spaces and architectures are *adaptive environmental interfaces – superspaces*; shaped through parametric tools based on human experience.

REFERENCES

- Asur, A., Huberman, B. A., Szabo, G., Wang, C., & Hewlett Packard. (2011, February 8). *Trends in social media : Persistence and decay* [Scholarly project]. In *Twitter Trends*. Retrieved June 15, 2013, from http://www.hpl.hp.com/research/scl/papers/trends/trends_web.pdf
- Atkin, Albert, "Peirce's Theory of Signs", *The Stanford Encyclopedia of Philosophy* (Summer 2013 Edition), Edward N. Zalta (ed.), URL = <http://plato.stanford.edu/archives/sum2013/entries/peirce-semiotics/>.
- Barthes, R., & Heath, S. (1977). *Image, music, text*. New York, NY: Hill and Wang.
- Barwise, Jon, and Jerry Seligman. *Information Flow: The Logic of Distributed Systems*. Cambridge: Cambridge UP, 1997. Print.
- Berger, Warren. *Glimmer: How Design Can Transform Your Life, and Maybe Even the World*. New York: Penguin, 2009. Print.
- Bohm, D., & Peat, F. D. (2000). *Science, order, and creativity*. London u.a.: Routledge. Print.
- Bohnacker, Hartmut, Benedikt Gross, Julia Laub, and Claudius Lazzaroni. *Generative Design: Visualize, Program, and Create with Processing*. New York: Princeton Architectural, 2012. Print.
- Brennan, K., Resnick, M., & MIT Media Lab. (2012). *New frameworks for studying and assessing the development of computational thinking* [Scholarly project]. Retrieved June 15, 2013, from http://web.media.mit.edu/~kbrennan/files/Brennan_Resnick_AERA2012_CT.pdf
Paper presented at annual American Educational Research Association meeting, Vancouver, BC Canada
- Cetina, K. K. (2009). The synthetic situation: Interactionism for a global world. *Symbolic Interaction*, 32(1), 61-87. doi: 10.1525/si.2009.32.1.61
- Congdon, Christine, Donna Flynn, and Melanie Redman. "Balancing "We" and "Me" - The Best Collaborative Spaces Also Support Solitude." *Harvard Business Review* Oct. 2014: 50-57. Web.
- Cukier, K., & Mayer-Schoenberger, V. (2013, May/June). The rise of big data. *Foreign Affairs*, 92(3), 28-40.
- Davidow, B. (n.d.). Skinner marketing: We're the rats, and facebook likes are the reward: Our internet handlers are using operant conditioning to modify our behavior. *The Atlantic*. Retrieved June 10, 2013, from <http://www.theatlantic.com/technology/archive/2013/06/skinner-marketing-were-the-rats-and-facebook-likes-are-the-reward/276613/>
- Dean, J., Corrado, G., Monga, R., Chen, K., Devin, M., Le, Q., ... Ng, A. Y. (2012). *Large scale distributed deep networks*. [Scholarly project]. Retrieved June 15, 2013, from http://static.googleusercontent.com/external_content/untrusted_dlcp/research.google.com/en/us/archive/large_deep_networks_nips2012.pdf
- Debord, Guy-Ernest. "Introduction to a Critique of Urban Geography." *Nothingness.org*. N.p., n.d. Web. 17 Jan. 2012. <http://nothingness.org>.
- De Certeau, Michel. *The Practice of Everyday Life*. Berkeley, Calif.: U of California, 2008. Print.
- Duggan, M., Brenner, J., & Pew Internet. (2013, February 14). The Demographics of Social Media Users. *Pew Research Center's Internet & American Life Project*. Retrieved from <http://www.pewinternet.org/Reports/2013/Social-media-users.aspx>
- Eco, U. (1994). *The limits of interpretation*. Bloomington, IN: Indiana University Press.

- Florida, R. (2002). Rise of the Creative Class. *Washington Monthly*. Retrieved June 22, 2013, from <http://www.washingtonmonthly.com/features/2001/0205.florida.html>
- Gallagher, Shaun. *How the Body Shapes the Mind*. Oxford: Clarendon, 2005. Print.
- Goffman, E. (1959). *The presentation of self in everyday life*. Garden City, NY: Doubleday.
- Goffman, E. (1971). *Relations in public; microstudies of the public order*. New York, NY: Basic Books.
- Goldstein, J. (1999). Emergence as a construct: History and issues. *Emergence*, 1(1), 49-72. doi: 10.1207/s15327000em0101_4
- Google. (2013). Flu Trends. *Google Technologoy for Social Impact*. Retrieved June 15, 2013, from <http://www.google.org/flutrends/>
- IBM Industries & Solutions. (n.d.). Apply new analytics tools to reveal new opportunities. *IBM Analytics – IT Business Intelligence*. Retrieved June 15, 2013, from http://www.ibm.com/smarterplanet/us/en/business_analytics/article/it_business_intelligence.html
- Joas, Hans. *G.H. Mead: A Contemporary Re-examination of His Thought*. Cambridge, MA: MIT, 1997. Print.
- Knorr-Cetina, K. (1999). *Epistemic cultures: How the sciences make knowledge*. Cambridge, MA: Harvard University Press.
- Koller, Daphne, and Nir Friedman. *Probabilistic Graphical Models: Principles and Techniques*. Cambridge, MA: MIT, 2009. Print.
- Lefebvre, H. (1991). *The production of space*. Oxford, OX, UK: Blackwell.
- Massey, D. B. (1984). *Spatial divisions of labor: Social structures and the geography of production*. New York, NY: Methuen.
- Mead, George Herbert., and Arthur E. Murphy. *The Philosophy of the Present: Lectures upon the Paul Carus Foundation, Third Series*. Chicago, IL: Open Court, 1932. Print.
- Monroy-Hernandez, A., & Resnick, M. (n.d.). Making projects, making friends: Online community as catalyst for interactive media creation. In K. Brennan (Author). doi: 10.1002/yd.377 NEW DIRECTIONS FOR YOUTH DEVELOPMENT; NO: 128; WINTER 2010 copyright WILEY PERIODICALS; INC: Published online in Wiley Online Library (wileyonlinelibrary.com)
- Osgood, C. E., Suci, G. J., & Tannenbaum, P. H. (1975). *The measurement of meaning*. Urbana-chicago-london, IL: University of Illinois press.
- Pine, B. J., & Gilmore, J. H. (1999). *The experience economy: Work is theatre & every business a stage*. Boston, MA: Harvard Business School Press.
- Princeton Survey Research Associates International. (2012, August 12). Pew Research Center's Internet & American Life Project. *iPoll Results*. Retrieved from http://pewinternet.org/iPoll_results.aspx
- Raison, Timothy, and Paul Barker. *The Founding Fathers of Social Science: A Series from New Society*. London: Scolar, 1979. Print.
- Rifkin, J. (2000). *The age of access: The new culture of hypercapitalism, where all of life is a paid-for experience*. New York, NY: J.P. Tarcher/Putnam.
- Rittel, H.W.J and M. M. Webber, Dilemmas in General Theory of Planning. *Policy Sciences* 4 (1973), 155-169. Amsterdam, Elsevier Scientific Publishing Company
- Ryall, M. D. (2013, June). The new dynamics of competition: An emerging science for modeling strategic moves. *Harvard Business Review*, 91(6), 80-87.
- Saussure, F. D., Baskin, W., Meisel, P., & Saussy, H. (2011). *Course in general linguistics*. New York, NY: Columbia University Press.
- Sha, X. (2011, August 02). *Recherche-Creation*. Lecture presented at University of California Humanities Research Institute (UChRI) Seminar in Experimental Critical Theory, Section VII, ReWired: [Asian+TechnoScience+Area] studies in University of Hawaii, Manoa.
- Shannon, C. (1948). A mathematical theory of communication. In *The bell system technical journal* (July,October ed., Vol. 27, Pp.379-423,623-656). Retrieved June 15, 2013, from <http://cm.bell-labs.com/cm/ms/what/shannonday/shannon1948.pdf>
- Shiffman, Daniel, Shannon Fry, and Zannah Marsh. *The Nature of Code*. San Bernardino: Shiffman, 2012. Print.
- Simonite, Tom. "Software That Augments Human Abilities." *MIT Technology Review* Mar.-Apr. 2014: 65-66. Print.
- Skinner, B. (1948). *Verbal Behavior*. Lecture presented at William James Lectures in Harvard University, Cambridge. Retrieved from http://www.bfskinner.org/bfskinner/PDFBooks_files/William%20James%20Lectures.pdf
- Soja, E. W. (1989). *Postmodern geographies: The reassertion of space in critical social theory*. London: Verso.
- Thompson, J. B. (1995). *The media and modernity: A social theory of the media*. Stanford, CA: Stanford University Press.
- Tschumi, Bernard. *Questions of Space: Lectures on Architecture*. London: Bernard Tschumi and the Architectural Association, 1995. Print.
- Tuan, Y. (1977). *Space and place: The perspective of experience*. Minneapolis, MN: University of Minnesota Press.
- Vygotskiĭ, L. S., & Cole, M. (1978). *Mind in society: The development of higher psychological processes*. Cambridge, MA: Harvard University Press.

- Waber, Ben, Jennifer Magnolfi, and Greg Lindsay. "Workspaces That Move People." *Harvard Business Review* Oct. 2014: 69-77. Print.
- Wilson, E. O. (1998). *Consilience: The unity of knowledge*. New York, NY: Knopf.
- Wolf, G. (2009, June 22). Know Thyself: Tracking every facet of life, from sleep to mood to pain, 24/7/365. *Wired.com*. Retrieved June 15, 2013, from http://www.wired.com/medtech/health/magazine/17-07/lbnp_knowthyself?currentPage=all
- Woodbury, Robert. *Elements of Parametric Design*. London: Routledge, 2010. Print.

**SOCIAL AND
BEHAVIORAL
RESEARCH**

Analysis of low-energy envelope and lighting measures for single-family dwellings in the West Indies

Cynthia Wilson¹, Hyojin Kim¹

¹School of Architecture and Planning, The Catholic University of America, Washington, D.C.

ABSTRACT: Most island nations of the West Indies rely predominantly on imported petroleum oil to meet their energy needs despite their strategic location to an abundance of renewable energy resources, which has contributed to significantly high electricity tariff in the islands. Meanwhile, buildings in the West Indies consume over 70% of the electricity generated in the islands. However, sparse information is available for architects, engineers, and homeowners about the efficient design and use of energy in buildings. Appropriate environmental design and construction such as passive and low energy design strategies which can be employed in the region are often neglected. Therefore, this paper presents the preliminary results from an analysis of the energy savings potential in single-family residential buildings in the islands by adopting several low-energy measures. The analysis was performed using eQuest 3.65 building energy simulation software. The ASHRAE Standard 55-2013 thermal comfort adaptive standard (ASHRAE 2013a) was used for the analysis of modeled thermal environments.

This study first developed baseline energy models that represent typical single-family residential buildings in the islands. To develop representative baseline residential models in the region, this study collected single-family housing data from home developers of the areas and performed interviews. The representative occupancy and operation scenarios in the islands were developed based on population statistics available in the island nations. The modeled energy consumption of base-case buildings are also compared against a previous study on residential building energy use in the region. Several energy conservation measures were then applied to the base-case models. These include measures for building orientation, envelope and fenestration, lighting, and equipment. Finally, this study developed recommendations for architects, engineers and homeowners in this region who wish to construct low energy residential buildings so as to avoid the needs for detailed analyses on every occasion when planning single-family residential buildings.

KEYWORDS: Low Energy Measures, Building Energy Simulation, West Indies, Energy Conservation Measures

INTRODUCTION

Most island nations of the West Indies rely predominantly on imported petroleum oil to meet their energy needs despite their strategic location to an abundance of renewable energy resources, which has contributed to significantly high electricity tariff in the islands. A report prepared for Caribbean Renewable Energy Capacity Support Project (CRECS) project stated that the cost for electricity for domestic use in Caribbean Community (CARICOM) states is among the highest in the world (Gardner 2011; Yopez-Garcia et al 2010).

Buildings in the West Indies consume over 70% of the electricity generated in the islands. The impact from climate change and increasing energy costs on small islands are now forcing building owners and operators to make changes and pursue sustainable development methods (Mimura et al 2007; UNEP 2010). Many of these owners are already aware that adaptation of more passive design techniques and low energy technologies will generate valuable co-benefits important to them, namely, short-term energy savings and long-term lifecycle cost reductions (Stern 2007). However, sparse information is available for architects, engineers, and homeowners about the efficient design and use of energy in buildings.

In recent years many single family dwellings that are constructed in the West Indies, have moved away from the traditional housing techniques, such as ventilated hipped or gabled roof, long roof overhang, high vaulted ceilings and open-design walls and have adopted a home design which require the use of mechanical equipment such as air-conditioning units. Hence it is now common to find many current single-family homes relying on the use of these costly systems for thermal comfort. However, these active systems demand high energy consumption. Meanwhile, appropriate environmental design and construction such as low energy envelope and lighting measures which can be employed in the region are often neglected.

Therefore, the purpose of this study is to identify and examine the potential energy performance benefits by applying low-energy principles appropriate for the average residential owner in this region. To accomplish this, the following objectives were considered:

1. Develop a base case that represents a typical single-family dwelling characteristics in West Indies.
2. Simulate and analyze the energy performance of the developed base-case single-family residential models.
3. Simulate and analyze the potential energy savings from the selected low energy envelope and lighting measures by applying them to the base-case models.

1.0 METHODOLOGY

The procedures used to determine the low energy envelope and lighting measures appropriate for the island states of this region is outlined in the following three phases. *Phase I Research* involved the collection of background materials needed to develop a base-case single-family residential model for the islands. To develop representative baseline residential models in the region, this study collected single-family housing data from home developers of the areas and performed interviews. Housing construction materials on these islands which consist of concrete, masonry and metal are preferred because of their durability in this climate. Roofing material of standing seam or concrete roof tiles, aluminum and metal windows and door frames are all materials resistant to the weather and termites. The ASHRAE Handbook Fundamental 2013 (ASHRAE 2013b) was referenced to assign appropriate thermal characteristics of the materials. Manufacturers' specifications of the typical household equipment and appliances used in this region provided information of energy and plug loads for the base-case models (TTEC 2014).

For the occupancy, lighting, and DHW schedules, the National Renewable Energy Laboratory (NREL) Building America House Simulation Protocols (NREL 2010) was used as reference. Several modifications were applied to the daily occupancy and equipment usage profiles. These modifications were based on the CARICOM Census report (CARICOM 2009) that defined the predominant average West Indian household size as the five persons' household. The report also provided information about the structure of the five persons' household which may consist of young children, teenagers, elderly and working adults with weekday normal working hours of 7AM to 4PM. The cooling set-point temperatures were selected to comply with the acceptability limits of ASHRAE Standard 55-2013 adaptive thermal comfort provision (ASHRAE 2013a) for this hot-humid tropical region.

Phase II Research performed the energy modeling and simulation of the base-case residential models developed using the information collected during the Phase I research. This included a determination of the annual energy consumption and thermal comfort. The base-case models have similar configuration and area, however one is designed with on-grade slab and the other with elevated slab. The International Weather for Energy Calculations (IWEC) hourly weather data for the island of Martinique was selected to perform the energy modeling calculations for this group of islands. The modeled energy consumption of base-case buildings were also compared against a previous study performed for similar residences in a neighboring region (Holmes and Kao (2010)).

Phase III Research explored and selected eight individual energy conservation measures (ECM) to optimize the energy performance of base-case single-family residential models. To select energy conservation measures (ECMs) appropriate for the region, this study reviewed recommendations of low energy envelope and lighting measures taken from analyses and case studies and guidebooks produced by the NREL technical information program (NREL 1994), Building America Best Practices Series (PNNL 2011) a technical handbook on Passive and Low Energy design published by the Commonwealth Secretariat (Baker 1987), the International Energy Conservation Code (IECC) 2012 (IRC 2012). Finally, this study combined and re-simulated the proposed individual measures as a group to maximize potential savings.

1.1. Geography and climate information of the West Indies

The Islands of the West Indies are located between latitudes 23° and 10° north of the equator. This chain of islands extends south from the Florida peninsula, curving 4,020 kilometers (2,498 miles) to the northeast coastline of South America. The West Indies archipelago separates the Caribbean Sea from the Atlantic Ocean. The archipelago is geographically divided into three groups. The focus of this study included all of the islands of the group known as the Lesser Antilles and the island of Jamaica, as shown in Figure 1. The Lesser Antilles is made up of a large arch of twenty one smaller islands, and is located in the south and southeast between latitude 10°N and 18°N of the equator.

The seasonal climate of the West Indies varies slightly from island to island. The different topography, size and orientation help to create local micro-climates for each island. In general however, there is a high rate of sunshine with very little daily or yearly variation throughout the entire West Indies. The trade winds blow throughout the year from the northeast, and are warm and moist (Taylor 2005). Generally, the temperature ranges from 23°C to 25°C (73.4°F to 77.0°F) in January and from 25°C to 31°C (77.0°F to 88.0°F) in July with small difference between islands (Wilson 2014).



Figure 1: Study area and the location of Martinique Island of which hourly weather file was selected for the analysis. (Source: Map from <http://city-data.com>)

2.0 BASE-CASE BUILDING DESCRIPTION

The base-case residential simulation models developed in this study are simple rectangular or square shaped plans with a 123.9 m² (1,334 ft²) of floor area. Table 1 summarizes the characteristics of the base-case single-family residential model used in the eQuest simulation tool in this study. Figure 2 shows the shape and geometry of the base-case model as well as a photo of a typical contemporary single-family residential building in the West Indies. The single story structures are constructed of either slab on grade or with slab elevated on concrete piers construction. The layout consists of three bedrooms, dining room, living room, kitchen and two bathrooms. The selected construction materials consist of 152.4 mm (0.5 ft.) concrete masonry blocks, 28 ga galvanized standing-seam metal roof with 609.6 mm (2 ft.) overhang, single pane casement aluminum windows. Household equipment and appliances included domestic water heater (DHW), kitchen and living room appliances. Wilson (2014) presents occupancy, lighting, and DHW schedules used in this study for the two separate zones: Living Room zone and Bedroom Zone.

Table 1: Base-case building description.

BUILDING CHARACTERISTICS	BASE CASE BUILDING DESCRIPTIONS	BASE CASE SIMULATION INPUT	INFORMATION SOURCE
ARCHITECTURAL			
Building Type	Single Family, detached dwelling-Slab on Grade		
Climate Zone	Zone 1A (IECC 2009)		
Gross Area	1,334 s.f.		
Floor Plan	3 Bedrooms Dwelling, Total 2 Zones	Living Area: 506.9 s.f.; Bedrm.: 707.2 s.f.	
Floor to floor Height (ft)	10 ft.		
Orientation	South facing		
CONSTRUCTION			
Wall Construction	Enclosure walls: 6" CMU with cement plaster finish both sides	Assembly U: 0.513	ASHRAE 2013b
Floor construction	4" concrete slab, tile paver finish	Assembly U: 5.56	ASHRAE 2013b
Roofing/Attic Construction	28 ga. Aluminum sheeting over radiant barrier sheets, vented attic	Assembly U: 0.73	ASHRAE 2013b
Window Construction	Single-pane glazing, aluminum frame no thermal break	U-factor: 1.30 SHGC :0.66	ASHRAE 2013b
Window Area		Living Area: 10% WWR Bedrm.: 12% WWR	
Infiltration	Estimated infiltration for small buildings	0.48	ASHRAE 2001
MECHANICAL SYSTEM			
HVAC System	Direct Expansion- Unitary Split System per zone	36,000 Btu unit, SEER = 16	
DHW	30 gallon Water Heater Electrical powered	Capacity= 30 gals. EF: 0.93	
SPACE CONDITIONS			
Space Cooling Setpoint	ASHRAE 55-2013 for Naturally Ventilated Buildings	80F (Occupied)	ASHRAE 2013a
Lighting	Incandescent lights	Living Area.: 1.2 W/s.f.c Bedrm.: 1.0 W/s.f.	Wilson 2014
Electrical Equipment	Home appliances and plug loads	Living Area: 1.0 W/sf Bedrm.: 0.2 W/sf	Wilson 2014



Figure 2: Typical contemporary single-family residential building in the West Indies (Left); and shape and geometry of the base-case model with a slab-on-grade configuration (Right).

The mechanical system which provides only cooling, consists of two split system air-conditioning (AC) units, located one each in the Living Room and Bedroom zones. The AC units were scheduled to be available only when the zones were occupied. The cooling set-points selected for the initial base-case analysis is 80 °F which is within the acceptable thermal comfort range of ASHRAE Standard 55-2013 for natural ventilated (NV) buildings in hot-humid climates. The zones was modeled to be naturally ventilated when natural ventilation can provide enough cooling to keep the zone temperature below 80 °F, and the zone was occupied. The DWH system selected was a 30 gallon, electrically-powered equipment, with an efficiency determined from the manufacture specifications. The average daily hot water consumption of 162.8 L/day (43 gallons /day) was determined by the 2012 IECC hot water equation (IRC 2012).

3.0 ENERGY CONSERVATION MEASURES (ECMS)

The main strategy for low energy building design for these islands is to reduce solar radiation throughout the year. The selection of low energy components for the building enclosure that aid in reducing solar heat gain made up the majority of the eight individual energy conservation measures that were selected. Seven of the measures involved building components directly affecting the enclosure. The other two measures consisted

of interior lighting and landscape shading. The simulation for preliminary analysis of each energy conservation measure was conducted using the eQUEST 3.65 program tool. The description of each measure is provided in the following sections.

- *ECM 1 Increased roof insulation:* This measure added rigid polystyrene insulation to accomplish a cumulative value of R-30 to comply with the requirements of the 2012 IECC for roofing assembly. In this case, the rigid insulation was applied above the ceiling to seal from the vented attic area.
- *ECM 2 Radiant barrier at ceiling:* This measure added radiant barrier at ceiling surface or the attic floor to re-radiate heat energy in the roof attic back towards the roof. The radiative heat which is also transmitted by the roof surface across the attic cavity can be minimized by reducing the emissivity of the underside of the roof covering or by increasing the reflectance of the cool inner surface of the ceiling.
- *ECM 3 Exterior wall insulation:* This measure added insulation to exterior wall enclosure adequate to achieve the R-value of 4. This is in compliance with 2012 IECC guide for homes in climate zone 1. This can be a combination of granular perlite poured in or blown through a nozzle into the masonry block cavity. Also, rigid insulation board may be applied over interior wall surface and furred with gypsum wallboard, U value 0.25 for the finish material.
- *ECM 4 Improved glazing:* This measure added efficient windows with double pane, low-e glazing. To comply with 2012 IECC guide for homes in Climate Zone 1, efficient windows should include low emissivity with solar heat gain coefficient (SHGC) value of 0.25.
- *ECM 5 Improved window frame:* To improve the efficiency of aluminum frames to control heat conduction, this measure changed the frame material to steel frame with thermal break for a U-factor (heat loss rate) of $2.856\text{W/m}^2\text{-}^\circ\text{C}$ ($0.503\text{Btu/h-ft}^2\text{-}^\circ\text{F}$).
- *ECM 6 Window overhang:* Window design guide by the Efficient Windows Collaborative (EWC) in association with the University of Minnesota provided information on window shading strategy (EWC 2014). Exterior overhangs have the advantage of reducing solar heat gain without diminishing the view. The guide sun angle calculator computed 304.8 mm (1 ft.) or greater overhang on all windows to provide shade for window glazing in this region where the sun's angle remains high in the sky throughout the year. This measure tested both one foot 304.8 mm (1 ft.) and 457.2 mm (1.5 ft.) window overhangs, and applied the 457.2 mm (1.5 ft.) to windows in the west and east facades.
- *ECM 7 Compact Fluorescent Lighting Power:* This measure replaced existing incandescent lamps with compact fluorescent lights (CFL). CFL use less energy with comparable brightness and color rendition.
- *ECM 8 Landscape Shading of Building Façade:* The east and west facades of buildings in tropical zones experience the greatest exposure to solar energy that is absorbed into the façade walls. This action contributes much heat during the day to interior rooms that are adjacent to these walls. The broad leaf deciduous trees of the tropics that remain green year round can provide cooling shade from the rays of the high angled sun. Trees are especially effective on the façade receiving the most solar exposure. Hence this measure is used to add trees (7.62 m (25 ft.) tall) to the building east and west facades.

4.0 SIMULATION RESULTS AND ANALYSIS

4.1. Base-case energy use and thermal comfort

Figure 3 presents the annual total site energy consumption for the base-case models. The annual site energy use of base-case models are: 7,561 kWh/year with on-grade construction and 7,312 kWh/year with elevated slab. By end-use category, the base-case consumption includes: 28.2% to 30.6% for cooling and fans, 26.0% to 26.9% for lighting, 24.6% to 25.4% for equipment, and 18.8% to 19.5% for water heater.

The modeled energy consumption of base-case buildings were also compared against a previous study performed for similar residences in a neighboring region (Holmes and Kao (2010)). Holmes and Kao (2010) developed and analyzed an energy performance of an 83.6 m^2 (900 ft^2), single-family residential building using simulation for the U.S. Virgin Islands. The annual energy use index (EUI) reported in this analysis was $48.2\text{ kWh/m}^2\text{-yr}$ for a NV building with no AC systems; and $85.9\text{ kWh/m}^2\text{-yr}$ for an AC building. Meanwhile, the base-case models of this study with mixed-mode buildings involving both NV and conventional AC systems reported: $61.0\text{ kWh/m}^2\text{-yr}$ for on-grade construction; and $59.0\text{ kWh/m}^2\text{-yr}$ for elevated slab construction, which are between the two numbers reported in the U.S. Virgin Islands study.

Figure 4 presents the simulated indoor thermal conditions of the base-case models on the ASHRAE Standard 55 NV chart and psychrometric chart when the zones are occupied. The simulated hourly indoor temperatures varied between 21.4°C (70.6°F) and 27.2°C (81.0°F) for the Living Room zone; and between

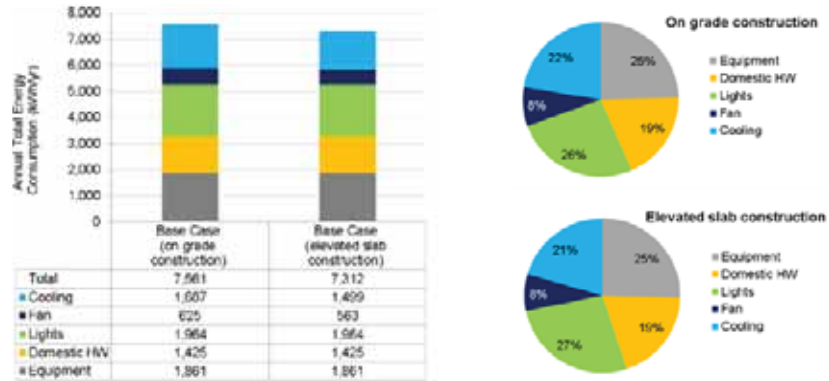

Figure 3: Annual total site energy consumption of base-case single-family residential models in the West Indies.

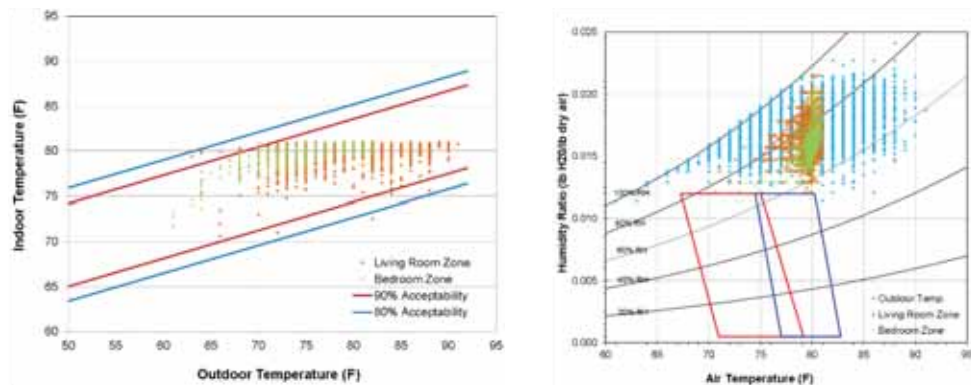

Figure 4: Simulated indoor thermal conditions of a base-case model (on grade construction) during occupied hours plotted on the ASHRAE 55-NV chart (Left) and the psychrometric chart (Right).

22.0°C (71.7°F) and 27.2°C (81.0°F) for the Bedroom zone, which fell within the ASHRAE Standard 55 NV's 90% thermal acceptability limits with negligible number of occupied hours within the 80% acceptability limits. However, when plotting the data on the psychrometric chart, it was found that the simulated indoor humidity levels were very high of which relative humidity ranged from 60% to 95% approximately.

4.2 Energy use reduction from various ECMs

Figure 5 shows the annual site energy savings (%) above the base case achieved by each ECM. Compact Fluorescent Lighting options yielded the largest annual total energy reduction by reducing lighting, cooling, and fan energy uses: 19.9% to 20.1%. The measure yielding the second largest energy savings is energy efficient windows (2.1% to 2.8%). The landscape shading of the building (i.e., deliberated placement of vegetation around the base-case models) was also found to be effective in preventing radiant heat build-up within the dwelling (1.4% to 2.5%). Increased wall insulation measures also yielded a relatively good amount of savings: 2.4%. The savings from other measures were small, less than 2%.

4.3 Combined ECMs

All eight Energy Conservation Measures (ECMs) were combined and re-simulated as a group. Because the measures are interdependent in many cases, the resultant savings of grouped measures are not always the same as the sum of the savings of the individual measures. In a similar fashion as the analysis of the individual measures, the group measures were simulated by modifying all the parameters of combined individual measures. Figure 6 presents the annual total site energy savings (%) above the base case achieved by combined ECMs: 29.4% with on-grade construction and 28.1% with elevated slab construction. Although this study combined all ECM measures as an example, it is recommended a future study to be performed to select the best combination measures which should be based on payback period analyses.

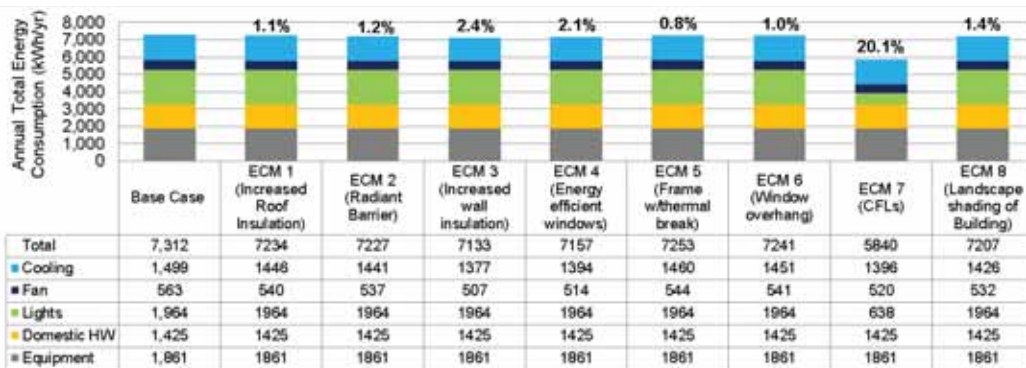
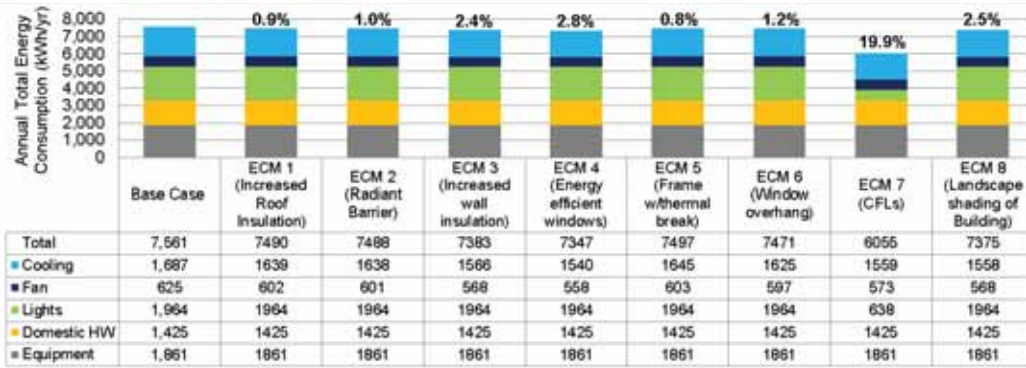

Figure 5: Annual total site energy consumption of individual ECMs: on-grade construction (Upper) and elevated slab construction (Below).

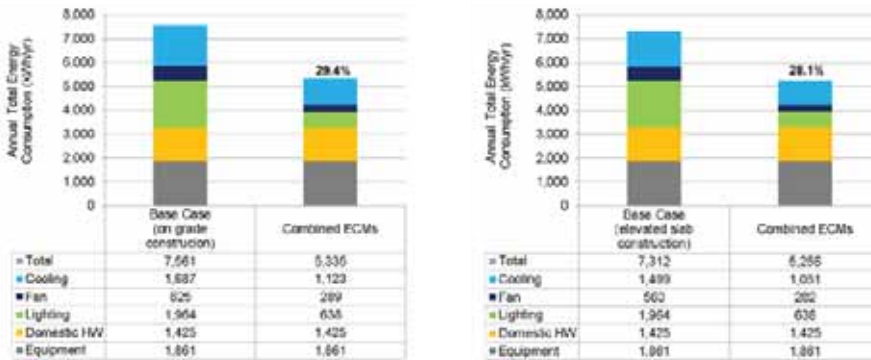

Figure 6: Annual total site energy consumption of combined ECMs: On-grade construction (Left) and (b) Elevated slab construction (Right).

5.0 CONCLUSION

This study developed base-case single-family residential models for the tropical humid islands of the West Indies and analyzed eight low energy conservation measures using the developed base-case models to determine potential energy savings from each individual measure as well as the combined group measures. The effects of the low energy measures on indoor thermal comfort were also studied. It was found that the simulated indoor thermal conditions generally fell within the ASHRAE Standard 55 NV's 90% thermal acceptability limits, but the simulated indoor humidity levels were very high of which relative humidity ranged from 60% to 95% approximately.

Although this study combined all ECM measures as an example, it is recommended a future study to be performed to select the best combination measures which should be based on payback period analyses. It is also recommended a study to be performed to analyze additional savings potential in other areas, including architectural design based on passive strategies, domestic hot water and equipment as well as renewables.

5.1. Recommendations for low energy residential buildings in the West Indies

Based on the results of the analysis, the following recommendations were developed for architects, engineers and homeowners in this region who wish to construct low energy residential buildings so as to avoid the needs for detailed analyses on every occasion when planning single-family residential buildings.

- Dwellings should be elongated on an east-west axis.
- Use double low-e glazing windows for all facades. Employing window shading when no other shading devices are employed. After these improvement are made to the windows, the window-to-wall ratio could be increased.
- Add insulation at the building enclosure, both at the roof/ceiling and exterior walls, to prevent solar heat gain on indoor occupied zones.
- Use compact fluorescent lights instead of incandescent lamps. This measure requires no additional construction activity, yet offered the greatest energy consumption reduction. This measure can be easily incorporated in existing dwellings.
- Consider planting trees around the site that would provide shade to the entire building. Broad leaf deciduous trees will provide shade throughout the year in tropical regions.

The proposed recommendations are expected to be widely used through consumer education programs that may also encourage the use of existing international *Building Energy Standards* and *Building Codes* in the residential building sector.

REFERENCES

- ASHRAE. 2013a. ANSI/ASHRAE Standard 55-2013, *Thermal Environmental Conditions for Human Occupancy*. Atlanta, GA: American Society of Heating, Refrigerating and Air-Conditioning Engineers, Inc.
- ASHRAE. 2013b. ASHRAE Handbook Fundamentals, *Chapter 26. Heat, Air, and Moisture Control in Building Assemblies—Material Properties*, Atlanta, GA: American Society of Heating, Refrigerating and Air-Conditioning Engineers, Inc.
- Baker, N.V. 1987. *Passive and Low Energy building Design for Tropical Island Climates*. Printed by The Commonwealth Secretariat, Pall Mall, London: Chapter 2 & 3.
- CARICOM. 2009. The CARICOM Environment in Figures, prepared by the CARICOM Secretariat, Regional Statistics Programme. 2009 report, Chapter 1. Population, Households and Families, : 59-63.
- EWC. 2014. Design Guidance for New Windows in a Hot Climate. Efficient Windows Collaborative. (<http://www.efficientwindows.org/downloads/HotDesignGuide.pdf>)
- Gardner, D. 2011. *Development and Implementation of a strategy for the promotion of Solar Water heating in CARICOM Countries*. The Caribbean Renewable Energy Capacity Support Project. 31-46.
- Holmes, S.H. and K. Kao. 2010. USVI Architectural Design Parameters for Naturally Ventilated and Low-Energy homes. EDIN Workshop 15– Architectural Residential Design Parameters.
- IRC. 2012. International Energy Conservation Code. International Code Council, INC.
- LBNL. 2000. Lawrence Berkeley National Laboratory, Environmental Energy Technologies Division. 01/04/2000. (<http://energy.lbl.gov/coolroof/>).
- McIntyre, D.A. 1978. Preferred air speeds for comfort in warm conditions. *ASHRAE Transactions*: 264-277.
- Mimura, N., L. Nurse, R.F. McLean, J. Agard, L. Briguglio, P. Lefale, R. Payet and G. Seminar. *Small Islands In: Climate Change 2007:Impacts, Adaptation and Vulnerability*. Contribution of Working Group II to the Fourth Assessment Report of intergovernmental Panel on Climate Change, Cambridge, United Kingdom: Cambridge University Press: 687-715.
- NREL. 1994. The Energy Efficiency and Renewable Energy Clearinghouse FS 186. Prepared for U.S. Department of Energy. National Renewable Energy Laboratory.
- NREL. 2010. Building America House Simulation Protocols. Prepared for U.S. Department of Energy Building Technologies Program. National Renewable Energy Laboratory.
- PNNL. 2011. *Building America Best Practices Series Volume 15: 40% Whole-House Energy Savings in the Hot-Humid Climate*. Prepared for U.S. Department of Energy. Pacific Northwest National Laboratory and Oak Ridge National Laboratory.
- Rohles, F.H., Konz, S.A., and Jones, B.W. 1983. Ceiling fans as extenders of the summer comfort envelope, *ASHRAE Transactions* 89 (1A):pp. 245-263.
- Stern, N. 2007. *The economic of Climate Change: The Stern Review*. Cambridge University Press Cambridge: 692.

- Taylor, M.A. 2005. Climate of Central America and the Caribbean. *Earth and Environmental Science. Encyclopedia of World Climate, Department of Physics, University of the West Indies.*
- TTEC. 2014. Trinidad West Indies. 2014 - Appliance Usage and its Impact on your Bill. Trinidad and Tobago Electricity Commission (www.ttec.co.tt).
- UNEP. 2010. Vital Climate Change Graphics for Latin America and the Caribbean. 3. Emissions and mitigation processes. Pg 23-32. Regional Office for Latin America and the Caribbean, United Nations Environment Programme. ISBN: 978-92-807-3120-0.
- Wilson, C. 2014. Passive and Low-Energy Technologies for Single Family Residential Buildings in the West Indies. M.S. thesis, School of Architecture and Planning, The Catholic University of America.
- Yepez-Garcia, Rigoberto Ariel, Johnson, Todd M., Andres, Luis Aberto. 2010. Meeting the Electricity Supply/Demand Balance in Latin America and the Caribbean. The World Bank Energy Unit: 21-28, 70-74.

Changing the agent of change: POEs for greater aesthetic and scientific data collection

Glenn Nowak¹, Talah Pejooch¹

¹University of Nevada Las Vegas, Las Vegas, NV

ABSTRACT: This paper presents a brief history of post occupancy evaluation methods. Analysis of evaluation techniques is brought into focus to illustrate both benefits and barriers within existing methods. Special attention is given to efficacy of methods in relation to pragmatics of information gathering: by whom, at what frequency, duration, etc. While functional and technical elements of building performance can be accurately measured through objective means such as energy audits, workflow analysis, acoustic and lighting measurements and other techniques, behavioral characteristics routinely rely on limited survey techniques, interviews, or focus groups susceptible to high levels of subjectivity or worse; specialization of questions/issues that are not equally accessible to building occupants.

With evidence of most POEs being conducted over the course of a day or perhaps a couple weeks, and typically only once about a year after construction, a new paradigm emerges to design methods of post occupancy evaluation that acquire building user information and deliver feedback to architects, building managers, or others in real time throughout the entire life cycle of the building. As POEs are most beneficial when information is made available to the widest potential audiences, the methods explored, here, attempt to translate high-level design principles into intuitive, graphical language for all to understand.

The presentation chronicles the process of integrating simulated three-dimensional environments, digital interfaces, and social media in a strategic shift in the discipline of conducting post occupancy evaluations. On-site installations, interactive software, and mobile applications are developed and simulated to test alternative advancements in POE orchestration. Conclusions address changes in a paradigm that seeks to fundamentally improve potential feedback quality and quantity through emerging technologies. Speculative simulations focus on buildings in the hospitality market but projections are applicable across multiple building types.

KEYWORDS: Post-Occupancy, Installation, Evaluation, Intuitive, Interactive

INTRODUCTION

In the digital and information age, many tools and techniques have been developed for the design, presentation, and fabrication stages of architecture. Here, the authors seek to apply some of these pre-occupancy means to post-occupancy evaluations. Emphasis is placed on the integration of intuitive technologies in hopes of fostering greater feedback from building users. Automation of translating user feedback into useful data sets for design team members and building owners is also sought through digital measures, which allow for long term analysis; tracking building performance over time.

An example of fixed-installation information gathering at a basic level has been implemented at the Changi International Airport in Singapore through a rating system displayed on iPads located throughout the building. These devices are placed in areas such as restrooms and immigration checkpoints and allow passengers to quickly input their feedback regarding both experience and efficiency with a quick tap of a finger to a correlating emoji that represents their level of satisfaction. This paper furthers the complexities of the information feedback loop by combining installations' camera capabilities with their interactive screens to invite critiques on the architectural context. We can now harness the power of data analytics combined with crowd sourced feedback to better understand how people interact with their physical environment.

1.0 CURRENT MEANS AND METHODS

POEs focus on building occupants and their needs. They provide insights into the consequences of past design decisions and the resulting building performance. This knowledge forms a sound basis for creating better buildings in the future. The performance of a building is evaluated regularly, although not necessarily in a self-conscious and explicit way. Post-occupancy evaluations are vital in our society because of the fundamental idea, which they are based on: better living space can be designed by asking users about their needs. Architecture, construction, building systems, environmental impact and programming are just a few examples of the thousands of factors that are involved in POE. The concept of building performance is at the core of post occupancy evaluations. POE is essentially a *statement of building performance*. POE can help organizations test new building ideas and operate more efficiently within their facilities.

There are three main elements of building performance to be evaluated in POE: functional, technical, and behavioral. Functional evaluations focus on the operational efficiencies and deal with the productive workflow between the building and its occupants activities. Technical evaluations deal with life, safety, and welfare issues such as the performance of building systems like structures, sanitation, fire safety, lighting, etc. Behavioral evaluations address occupant perceptions and psychological needs pertaining to building use and social interactions within spaces.

There are various obvious benefits to the conducting of POE. Facility managers gain insights on what needs attention in existing building stock. Organizations benefit from focused analysis on operational efficiencies. Professional/human benefits are among the most important outcomes of POE as a goal of the process is to positively influence the (re)creation of safe, comfortable, and productive environments for people. Among the current available methods of POE, common evaluation techniques for addressing people and their perceptions of the built environment include: walk through and observations, interviews, focus groups, workshops, questionnaires, and measurements.

According to a series of POE case studies documented by Bordass et al.,

Relatively modest exercises can have large effects. User Group members found that they could learn a lot from asking occupants what they thought: often their perspectives were very different. 'Designers are not users, though they often think they are' (Nielsen, 1993, 13). For example, occupant comments on the internal environment can be a more useful and cost effective starting point than instrumented monitoring, as each occupant experiences their own specific environment; and perceptions of real buildings – particularly ones that make use of natural light and ventilation and incorporate good user control – can be very different from predictions based on work in climate chambers in which the subject tends to be a passive participant (Bordass et al. 2005).

However, these modest inquiries typically fall short of inviting occupants to put forth their own proposals to solve a particular problem in a particular place. Instead, most traditional surveys collect information about the occupants' perceptions. Then, the task of trying to match the feelings expressed on a survey to the architectural modifications available in the real world falls on a third-party to hypothesize.

1.1. Where to apply new means

While the current techniques offer a range of data collection opportunities, there are a number of barriers inherent in each that can keep valuable information from being attained by the evaluators. There is often a lack of user feedback in survey methods. Without significant participation, achieving statistically viable results is difficult. Often there is not enough incentive for participation or a clear understanding of how the feedback from users can be used to inform building improvements or adjust best-practices for future development. Wasted time and frustration in formulating guidelines for future design and construction can be the effect of reacting to non-critical building assessments and not ascertaining more informative insights. Technical language requires surveyors with a background in the architectural industry, yet translating technical information into concepts approachable to all occupants can be challenging and is occasionally the source of another impedance to the POE process.

Not only is it important for respondents to POE surveys, interviews, focus groups, etc. to understand graphical language and architectural representations, it is equally important for evaluators to understand and disseminate their feedback. The greatest benefits from POE come from closing the loop by connecting feedback to the industry at large (and not just the building being evaluated).

For reasons of greater participation and dissemination with POE, a process of developing an intuitive virtual 3D environment interface is proposed. The idea is to expand on existing methods of information gathering for the improvement of structures and community spaces through,

wearable or handheld technologies that attempt to facilitate interactions between people, between people and computers or between people and artifact... and the use of large displays in shared contexts (McDonald et al. 2008)

As smart phones, tablets, and screens have become commonplace and social media connects people and ideas across great expanses of time and space, harnessing these opportunities for the tightening of data collection on the built environment represents the continued trend of better understanding design performance. These virtual world interfaces would integrate design features of the real world and allow users to interact with intuitive tools designed to accommodate respondents' instinctual desires to change aspects of their environment. The tool would be implemented in various parts of the built environment using Building Information Models of existing facilities and near limitless surveyor-developed design intervention opportunities.

1.2. The POE digital interface

Gamification has become an increasingly popular way to improve user engagement and motivation in real-world market research (Cechanowicz et.al. 2013, 58). The (next) trend in POE is the gamification of questionnaires, surveys, walkthroughs, and other evaluation techniques. As intuitively as phone apps have non-architect users designing virtual worlds and envisioning themselves in those spaces (ex. MineCraft, SimCity), the POE Digital Interface seeks to be the omnipresent application or integrated installation for building occupants to respond to and re-envision their real surroundings. It aspires to be the approachable alternative to the pen and paper text-based survey, and in the process, translate user feedback into more immediate architectural data. And as meaningful architectural analysis can be difficult to gather from static surveys, gamification has been shown to “increase creativity and participant interest” (Adamou 2012).

The methods of acquiring occupant feedback expand from a traditionally set timeframe (ranging from several minutes to a couple days about year after building completion) to a continuous period spanning the life of a building. The means of delivering information back to stakeholders happens in real time instead of requiring additional resources to collect and interpret data. Moreover, information does not have to stop at traditional stakeholders but can be shared beyond the institution whose building is being evaluated or beyond the architects and consultants involved. The information could be made easily available in educational settings, governmental agencies, or open source databases for the betterment of the industry.

1.3. Sample scenario

POE Design Interface is launched on location by opening a software application, which is accessed via smartphone or on site control panel. A three-dimensional scene of the immediate urban, building, or interior environment is rendered and the user is then prompted to select an area to address. From the menu screen, the user is immersed in the selected area with even greater detail. Details enable users to request different types of augmented visualizations to the virtual world. Input is visually expressed in three dimensions with the ability to alter form and function through manipulation of color, texture, scale, and object type.



Figure 1: POE Digital Interface Flowchart - Source: (Pejoooh 2013)

Alternative scenarios generated by POE Design Interface users are archived as overlays corresponding to original (as-built) models in order to measure degree of variation and trends over time. Augmentations can include alternative circulation patterns (created by users vs. intended/existing), program planning, lighting, ventilation, landscape features, interior/exterior building materials/color/texture, etc. Suggested changes that critically impact the building could be instantly identified and assessed according to current industry standards, codes, cost analysis, and environmental impact among others. The ability of occupants to choose what to address about their building and where, when, and how to address it invites more feedback (and arguably more meaningful feedback) than a survey conducted at a prescribed place and time.

For more public engagement with individuals' POE Design Interface feedback, temporary or semi-permanent installations for design visualizations can be integrated into the building. Video-mapped surfaces can display user input, or design suggestions can be translated into various scaled models to elicit more comments. This can be especially useful when other aspects of the POE have helped to identify specific areas of a project that require additional analysis.

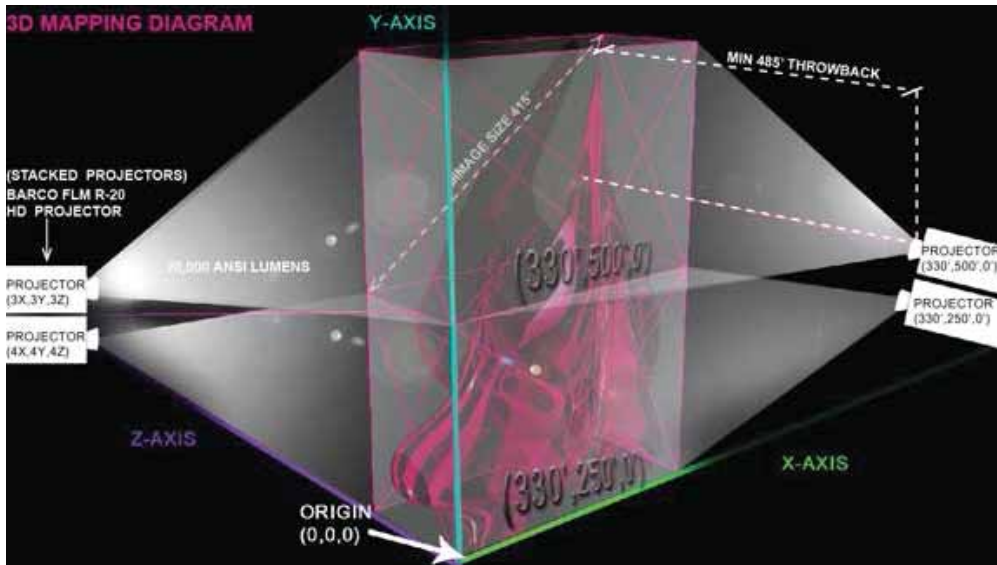

Figure 2: POE Digital Interface Optional Video mapping/installation - Source: (Pejoo 2013)

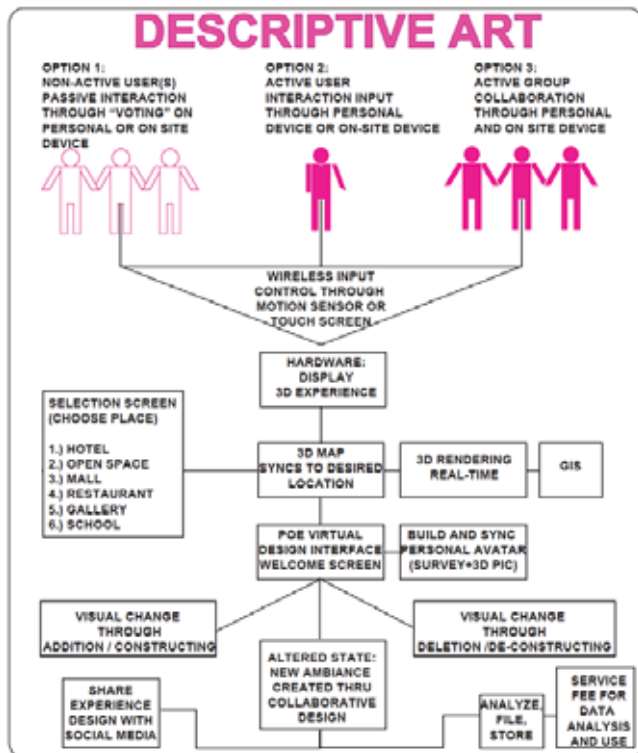

Figure 3: POE Digital Interface Flowchart - Source: (Pejoo 2013)

Integrated opportunities abound in establishing user-driven feedback loops that engage the spaces people spend most of their lives. End goals include three main items for consideration. The first is a post occupancy report card which visually and numerically evaluates data from individual user input in order to determine architectural performance against expectations and/or industry standards. The second is a digital copy of user input will be sent to the user when provided with an email address and/or social media tag. Users have the option of "sharing" their experience online on social media sites in real time and can collect

experiences and stitch them together in a portfolio format. And third, the goal of fosters social collaboration to inform design thinking is paramount to process of designing for people.

1.4. Example market/users

Public and private entities that can benefit from a POE Digital Interface include architects, urban planners, various building consultants, owners, developers, managers, franchises, governmental agencies, research groups, and individuals. While valuable data could be culled from implementing these practices in the most modest of dwellings, location based markets would likely produce the most cost-effective and insightful evaluations. Areas or building types that attract a diverse population ready to immerse themselves in their surroundings (and have fun reimagining those surroundings) are ideal candidates to test the application. Theme parks, boardwalks, the Las Vegas Strip, hotels, parks, high density areas, and large scale work places stand to benefit most.

At the time of this writing, fee structures have not be established for the POE Digital Interface. Important ethical considerations are being weighed between long-term service and information fees on one side and one-time installation costs on the other. Charges for data requested over time could include increasing premiums for type of feedback; moving from written summaries still requiring interpretation, to statistical analysis, graphical overlays, and video footage (user/crowd reaction) which would require less and less interpretation. However, with the core tenet of learning from all evaluations of our built environment, the POE Digital Interface may only seek compensation for initial download of the application software and/or installation of public presence video projections, on-site kiosks, and similar integration of smart screens into evaluation areas.

CONCLUSION

Information from POE can provide insights into problem resolution and provide useful benchmarks to which other projects can be compared. The POE Digital Interface provides opportunities for improving the effectiveness of building engagement, and it has the ability to more easily share post occupancy analysis with people outside any particular project being evaluated. The active participation not only creates a more dynamic environment but also fosters a sense of community within destinations. The technology has the potential as a powerful social tool to enable the public to educate themselves about design (through a participatory process of evaluation). It further educates architects and owners on what the general public may prefer in buildings in terms of design, program, and functionality. And, a more intuitive, user-friendly, real-time (all the time) feedback loop has the ability to collect more meaningful information about design effectiveness and the evolving character of a building throughout its life-cycle. Next steps to test the effectiveness of this tool would include an experiment, which compares the data retrieved from the interactive digital interface with the data retrieved by traditional survey methods. Integration of the technology is being explored for future use in hotel guest experience surveys.

REFERENCES

- Adamou, B. 2012. *Giving Research the NOS Effect*. Proc Net Gain 6.0 MRIA Conference.
- Bordass, B., and Leaman, A. 2005. *Making feedback and post-occupancy evaluation routine: 3 Case studies of the use of techniques in the feedback portfolio*. Building Research & Information, DOI:10.1080/09613210500162032. London: Routledge.
- Chechanowicz, J., Gutwin, C., Brownell, B., and Goodfellow, L. 2013. *Effects of Gamification on Participation and Data Quality in a Real-World Market Research Domain*. Gamification '13 Proceedings of the First International Conference on Gameful Design, Research, and Applications.
- McDonald, D. W., McCarthy, J. F., Soroczak, S., Nguyen, D. H., Rashid, A. M. 2008. *Proactive displays: Supporting awareness in fluid social environments*. ACM Trans. Comput.-Hum. Interact. DOI = 10.1145/1314683.1314684
- Preiser, Wolfgang F.E. 2002. *Learning from Our Buildings: A State-of-the-practice Summery of Post-Occupancy Evaluation*. Washington DC: The National Academies Press.

Constructing productivity: Investigating the types of spaces preferred for a range of work tasks

Giancarlo Mangone¹, Henk Staats², P.G. Luscueri³

¹ Carleton University, Ottawa, Ontario

² Leiden University, Leiden, The Netherlands

³ Delft University of Technology, Delft, The Netherlands

ABSTRACT: The type and range of tasks that knowledge workers conduct has received considerable attention by a myriad of research domains over the last century. However, the relative value of various typical workspace types for performing a variety of typical work tasks has received relatively scant research attention. In addition, existing research indicates that natural environments may be beneficial spaces for conducting a diverse range of work tasks, yet the relative value of conducting work tasks in natural environments compared to typical work environments is still not well understood.

To this end, this paper reviews the results of a survey of knowledge workers that was conducted in Delft, The Netherlands in 2012. The primary goal of the survey was to identify the types of work environments that promote the performance of knowledge workers, in regards to a diverse range of work tasks.

Participants were presented with images of different physical environments, including typical work environments, such as an open floor workspace, cellular office, and lounge, as well as several different natural environments. The participants then ranked the different physical environments in descending order, from best to worst, in terms of their perception of how well the workspaces promoted their performance on the work tasks.

The results of the survey indicated that knowledge workers prefer a much broader and diverse range of work environments than are currently provided in office buildings. Notably, natural environments were found to be considerably more preferred than traditional work spaces for conducting a number of work tasks, particularly creative work tasks, such as brainstorming. In addition, at least one type of natural environment was ranked as at least the third best work environment for every work task evaluated.

KEYWORDS: Worker Performance, Creativity, Plants, Office Design

INTRODUCTION

Physical work environments influence worker performance and well-being in a myriad of ways. For instance, existing research indicates that the level of influence of physical work environments on the performance of knowledge workers varies based on the type of work task (Meusbürger, 2009). Moreover, the effects of specific types of physical work spaces on worker performance have been found to vary by work task. For instance, Forster (2009) found that certain physical workspace types can prime occupants to be creative, while Amabile (1999) found that work projects that were rated high in creativity had significantly different physical work environments from those rated low in creativity. Moreover, Leung et al. (2012) found that knowledge workers were more creative when they conducted brainstorming activities in open spaces, compared to brainstorming in an enclosed, narrow work space, such as a cellular office. In contrast, a review of existing literature by Davis, Leach, and Clegg (2011) indicated that conducting complex tasks in isolation increases task performance, and allows creative workers to avoid overstimulation and other environmental stressors associated with non-private workspaces. Thus, it is apparent that various workspace types are more and less suitable for conducting different work tasks, and thereby affect worker performance.

Interactions with natural environments and biota, particularly forests and vegetation, have been found to benefit worker performance, as well as individual well-being and comfort, in research conducted by a variety of scientific disciplines in diverse cultures throughout the world. For instance, the presence of vegetation has been found to improve occupants' overall comfort as well as thermal comfort, space use rates, and their perceptions of the quality of their environments, including greater air quality, acoustics, and visual comfort and light levels (Bergs, 2002; Fjeld, 2002; Hellinga & de Bruin-Hordijk, 2010; John Hesselink et al., 2008; Mangone, Kurvers, & Luscueri, 2014; Stiles, 1995; Vink, Groenesteijn, Blok, & de Korte, 2008).

Moreover, researchers have found that plants can improve worker productivity between 10-15%, and increase creativity by 11-30% (Atchley, Strayer, & Atchley, 2012; John Hesselink et al., 2008; Knight & Haslam, 2010; Lohr, Pearson-Mims, & Goodwin, 1996; Marchant, 1982; Nieuwenhuis, Knight, Postmes, & Haslam, 2014; Shibata, 2004). Specifically, worker performance on tasks requiring substantial concentration, such as focus related work tasks, has been found to improve when participants interact with natural environments and plants (Berman, Jonides, & Kaplan, 2008). In addition, a study by Vink et al. (2008) found that knowledge workers occupied a garden lounge space 16.9% more than a typical office lounge space, even though the garden space did not provide seating. Moreover, occupants of the garden space conversed 20.6% less than occupants of the typical lounge space, yet the percentage of conversations that were work related were greater in the garden

space. Hence, gardens were found to be preferred by occupants, as well as increase occupant use rates of informal meetings spaces, even when more comfortable lounge spaces were available. These findings suggest that natural environments can be beneficial informal meeting and work break environments. Moreover, the occupation of natural environments can promote occupants to focus on work related topics in informal meeting conversations. Taken together, the results of these studies also indicate that vegetation may not function as a distraction stimulus, but rather as a positive stimulus, even during cognitively demanding tasks. Therefore, natural environments may be beneficial environments to conduct a diverse range of tasks.

However, the suitability of natural environments for a range of work tasks has not yet been thoroughly evaluated. Moreover, the comparative effectiveness of the various workspace types commonly present in work environments on improving the performance of occupants, with regard to a diverse range of work tasks, has yet to be evaluated. Thus, the focus of the study presented in this paper was to evaluate the effect of a diverse range of commonly used office workspace types, as well as natural environments, on worker performance, with regard to a diverse range of work tasks that have been identified in existing literature.

1.0 METHODS

1.1. General overview of survey

The goal of this research project was to evaluate the relative value of various existing and innovative workspaces, in terms of promoting the performance of knowledge workers when conducting various work tasks. This research question was evaluated through the development and administration of a semi-structured, questionnaire based survey to 54 knowledge workers. The survey included both brief and extended responses.

1.2. Participant work environment context

The survey was conducted at the Delft University of Technology Faculty of Architecture and the Built Environment building (BK City) in Delft, The Netherlands, in the fall of 2012. The Faculty of Architecture was located in a separate building until May 2008, when the building burned down. An existing building on campus, whose construction began in 1917, but due to numerous issues did not have an official occupant until 1948, was subsequently renovated and renamed 'BK City'. In September 2008, the Faculty of Architecture moved into BK City. The new work environment was designed to provide a variety of workspace types for the faculty, including cellular offices, open floor work spaces, public and private informal meeting spaces, lab rooms, lounges, cafes, and public and private lecture spaces. Thus, the participants had experience working in a range of work types.

1.3. Participants

The faculty members at BK City are comprised of educators and researchers, and are organized into four departments : Architecture, Architectural Engineering + Technology, Real Estate + Housing, and Urbanism. Since the target job type for this survey was knowledge workers, the research faculty within BK City were categorized as the survey population. In the fall of 2012, there were 126 staff members who were actively involved in research projects and were physically working at BK City, 81 males (64.3%) and 45 females (35.7%). The mean age of the researcher population was 42.1 years (SD=10.72).

For the pilot study, 10 volunteer researchers were interviewed. These volunteers were randomly selected from the researcher population at BK City. There were 7 male participants (70%) and 3 female participants (30%), with a mean age of 37.1 years (SD=11.51).

For the second phase of the survey, a stratified sampling approach was employed to enlist participants, in order to ensure that the knowledge workers from the four departments were proportionately represented, as well as to ensure that the participants represented the broad range of perspectives present within BK City (Foster, 1995). 54 volunteer researchers were interviewed. There were 31 male participants (57.4%) and 23 female participants (42.6%), and their mean age was 41.4 years (SD=10.31). The distribution of the participants among the four departments was similar to the distribution of the BK City researcher population distribution among the four departments.



Figure 1: Open workspace.



Figure 2: Lounge.



Figure 3: Informal public meeting.



Figure 4: Lab.



Figure 5: Informal private meeting.



Figure 6: Cellular Office.



Figure 7: Forest Amphitheatre.



Figure 8: Meadow.



Figure 9: Dense Forest.



Figure 10: Park.



Figure 11: Formal Meeting.



Figure 12: Lecture Hall.



Figure 13: Cave.



Figure 14: Gym.



Figure 15: Café.

1.4. Work task selection process

Existing literature has identified a range of work tasks that knowledge workers typically conduct. The range of work tasks that were identified and evaluated in this research project, as defined in Table 2, were identified based on evidence from an extended literature review. Special attention was given to identifying work tasks that extant research indicates may have different physical work environment requirements. The results of this review included a broad range of creative and non-creative work tasks, including work tasks identified by Olgay's stage based creative process model, as well as Treffinger's integrated model, among others (Davis et al., 2011; Funke, 2009; Robinson, 2012; Treffinger, 1995).

1.5. Workspace type + image selection process

Based on the results of a literature review, ten different workspace types were identified as being representative of currently available work space types that office environments provide for knowledge workers to conduct various work tasks. Five different types of nature space types were included, in order to evaluate the influence of different types of natural environments on occupants' work performance, in regards to a range of diverse work tasks. Since the goal of the survey was to evaluate the performance of knowledge workers in existing workspace types and nature space types, the initial images that were selected to represent each space typology were selected based on their representativeness of typical work spaces for each typology. Extraordinary workspaces and natural spaces were avoided, such as spaces with excessive colors, flowers, and expensive furniture, in order to reduce the potential of participants to respond to unique qualities of these extraordinary images, instead of to the qualities of the typology. The perception of the qualities of the selected images, and their representativeness of the intended space types, were then evaluated by the participants during the pilot phase of the experiment, and were revised, and in some cases replaced, accordingly. A follow up survey of 33 participants was conducted, which evaluated the participants' perception of ten different spatial qualities in the images through a 7-point Likert scale self-report based survey. The measured spatial qualities included the perceived level of noise, light, privacy,

fascination stimuli, and naturalness. The results of this survey indicated the final image set was perceived by the participants as intended. The final image set is illustrated in Figures 1-15.

1.6. Survey method

The participants were first given pictures of the fifteen workspace typologies and asked to arrange them from the space they would most prefer to occupy in general, to the least. The participants were advised to spend one to two minutes on the task. The purpose of this exercise was for participants to familiarize themselves with the image set, since it was observed in the first round of the pilot study that participants didn't notice influencing spatial qualities of some of the images until the second question. Based on the participants' feedback, the addition of this exercise in the second pilot study corrected this issue.

Following the image orientation exercise, the participants were given some instructions before conducting the next part of the survey. For each work task, the participants were asked to consider the nature and typical work spaces as being equally accessible from their current location. In addition, the participants were instructed to consider the nature spaces to be comfortable to occupy, similar to a warm, spring day, without glare issues, temperature issues, or excessive winds. The nature spaces were to be considered as providing access to all the necessary facilities, including access to internet, electricity, secretary services, bathrooms, etc., and to be able to be furnished with any furniture desired for the specific work task. However, the participants were asked to identify any change in furniture that they desired. These instructions were developed based on the feedback of the participants of the first pilot study in order to ensure participants considered the nature spaces as equally comfortable and accessible as typical workspaces. This was because the goal of the survey was to evaluate the performance potential of forest typologies within office buildings, so occupants within these space typologies would not be subject to adverse weather conditions or lack of availability of resources.

Following these instructions, the participants were then asked to arrange the pictures of the workspace typologies, from the space they believed they would best be able to conduct the given work task to the space where they would least be able to conduct the work task. This process was repeated for the sixteen work tasks identified in Table 2. During the first pilot study, it was observed that most participants had difficulty ordering spaces after they identified the four or five best and worst performing spaces, with several participants reporting the spaces outside the four or five best and worst spaces were very similar in performance, and for some of the participants, these less important spaces were sometimes interchangeable. This finding is illustrated by the fact that several participants selected two and sometimes three spaces for fifth and sixth best and worst spaces for various work tasks. In addition, these participants took the most time to complete the interview. These findings indicate that the degree of accuracy of participant responses after identifying the four best and worst typologies was relatively less reliable. Thus, the spaces that were not selected for the four best and worst performing were not assigned a value in the analysis of the results presented in this paper. This method is believed to be the most accurate accounting of the research findings by the authors, based on participant feedback and responses. In addition, participants that were asked to order every workspace for each worktask, on average, took more than twice as long to answer each question (1 to 2 hours, compared to 30 to 60 minutes). However, one participant was able to order all workspaces for each work task without much difficulty or time. Thus, in the second pilot study, participants were asked to identify the four best and four worst workspace typologies for each work task. In general, this resulted in significant time savings, and the participants reported clear distinctions in performance between spaces.

1.7. Participant performance measurement method

This survey evaluated knowledge workers' perceptions of how well various workspace types promoted their performance on the evaluated work tasks. Knowledge workers have a unique perspective of their subtle interactions with their physical and social work environment that affect their personal work performance. Supervisor evaluations could provide another level of validation, in terms of assessing the effect of different physical workspaces on the participant's performance. However, without direct access to the workers' cognitive processes and behaviors, supervisors, facility managers, and co-workers are not able to comprehensively perceive the positive and negative effects of the social and physical work environment on their work task performance and creativity (Shalley, Zhou, & Oldham, 2004). Furthermore, self-reported creativity has been previously correlated to supervisor-reported creativity (Axtell et al., 2000). Nevertheless, future research should evaluate the performance of knowledge workers in the various workspace types evaluated in this survey. However, this type of evaluation was outside the scope of this research project.

This self-report method has several inherent weaknesses. For example, the experiment can be susceptible to common method bias and social desirability bias (Dul, Ceylan, & Jaspers, 2011; Robinson, 2012). However, the potential for these biases was reduced by informing the participants that there were no right or wrong answers, and that their responses were anonymous. They were also told that the goal of the survey was not to prove a hypotheses, but rather to learn what kind of environments improve and reduce their work performance for different work tasks. Furthermore, by allowing respondents to expand upon their responses, the authors were able to further assess if the participants' responses were being influenced by other biases. (Robinson, 2012).

2.0 RESULTS AND DISCUSSION

Overall, the forest workspace types, *n1-n4*, were preferred considerably more than traditional office workspaces, as described in Tables 1 and 2. For instance, in Table 1, the dense forest space, *n1*, was preferred more than the other tested spaces for four work tasks, and second most for six tasks, as shown in row 1 of Table 1.

Table 1: Participants' quantitative preference of workspace types.

		Type of Worktask (1-17)															
		1	2	3	4	5	6	7	8	9	10	11	12	13	14	15	16
Participant Workspace Type Preference (from most preferred to least preferred, per worktask type)	n1	4	6	3	2	0	0	0	0	0	0	0	0	0	0	0	0
	n2	4	5	1	1	1	1	1	1	0	0	0	0	0	0	0	0
	n3	0	0	3	7	3	0	1	1	0	0	0	0	0	0	0	0
	n4	2	1	3	3	0	2	1	0	1	0	1	0	1	0	0	0
	o1	0	0	2	0	5	0	4	1	1	0	0	1	0	0	1	0
	o2	0	0	0	1	1	5	2	4	1	1	0	0	0	0	0	0
	o3	2	1	0	0	2	0	1	1	0	1	1	2	1	3	0	0
	o4	0	0	0	1	0	3	0	1	3	3	1	2	0	1	0	0
	n5	0	0	0	0	1	3	1	1	0	3	2	3	1	0	0	0
	o5	2	1	0	0	1	0	1	1	0	0	3	0	2	3	1	0
	o6	1	1	1	0	0	0	0	0	1	2	2	4	3	0	0	0
o7	0	0	2	0	1	0	0	0	1	1	3	2	2	3	0	0	
o8	0	0	0	0	0	1	2	0	0	1	1	1	4	5	0	0	
o9	0	0	0	0	0	0	0	0	0	0	0	1	0	0	0	8	
o10	0	0	0	0	0	0	0	0	0	0	0	0	1	0	5	9	

Note : Workspace type definitions : n1=dense forest; n2=meadow ; n3=park ; n4=forest amphitheater; n5=cave; o1=lounge; o2=informal public; o3=cellular office; o4=informal private; o5=conference room; o6=open floor workspace; o7=lab; o8=café; o9=lecture; o10=gym

Table 2: Participants' workspace type preference, per work task.

Sum of Participants' Order of Preference of Workspace Types for all Activities
(from most preferred (1) to least preferred (16))

		1	2	3	4	5	6	7	8	9	10	11	12	13	14	15	16	17
Workspace Type	n1	Green	Green	Green	Green	Green	Green	Green	Green	Green	Green	Green	Green	Green	Green	Green	Green	Green
	n2	Green	Green	Green	Green	Green	Green	Green	Green	Green	Green	Green	Green	Green	Green	Green	Green	Green
	n3	Green	Green	Green	Green	Green	Green	Green	Green	Green	Green	Green	Green	Green	Green	Green	Green	Green
	n4	Green	Green	Green	Green	Green	Green	Green	Green	Green	Green	Green	Green	Green	Green	Green	Green	Green
	o1	Green	Green	Green	Green	Green	Green	Green	Green	Green	Green	Green	Green	Green	Green	Green	Green	Green
	o2	Green	Green	Green	Green	Green	Green	Green	Green	Green	Green	Green	Green	Green	Green	Green	Green	Green
	o3	Green	Green	Green	Green	Green	Green	Green	Green	Green	Green	Green	Green	Green	Green	Green	Green	Green
	o4	Green	Green	Green	Green	Green	Green	Green	Green	Green	Green	Green	Green	Green	Green	Green	Green	Green
	o5	Green	Green	Green	Green	Green	Green	Green	Green	Green	Green	Green	Green	Green	Green	Green	Green	Green
	o6	Green	Green	Green	Green	Green	Green	Green	Green	Green	Green	Green	Green	Green	Green	Green	Green	Green
	o7	Green	Green	Green	Green	Green	Green	Green	Green	Green	Green	Green	Green	Green	Green	Green	Green	Green
	o8	Green	Green	Green	Green	Green	Green	Green	Green	Green	Green	Green	Green	Green	Green	Green	Green	Green
	o9	Green	Green	Green	Green	Green	Green	Green	Green	Green	Green	Green	Green	Green	Green	Green	Green	Green
	o10	Green	Green	Green	Green	Green	Green	Green	Green	Green	Green	Green	Green	Green	Green	Green	Green	Green
	o11	Green	Green	Green	Green	Green	Green	Green	Green	Green	Green	Green	Green	Green	Green	Green	Green	Green
	o12	Green	Green	Green	Green	Green	Green	Green	Green	Green	Green	Green	Green	Green	Green	Green	Green	Green
	o13	Green	Green	Green	Green	Green	Green	Green	Green	Green	Green	Green	Green	Green	Green	Green	Green	Green
o14	Green	Green	Green	Green	Green	Green	Green	Green	Green	Green	Green	Green	Green	Green	Green	Green	Green	
o15	Green	Green	Green	Green	Green	Green	Green	Green	Green	Green	Green	Green	Green	Green	Green	Green	Green	
o16	Green	Green	Green	Green	Green	Green	Green	Green	Green	Green	Green	Green	Green	Green	Green	Green	Green	
o17	Green	Green	Green	Green	Green	Green	Green	Green	Green	Green	Green	Green	Green	Green	Green	Green	Green	

Note : Worktask definitions : (I) = individual task (G) = 2-6 person group task; (1)Administrative/non-technical work: email, calendar ,etc.; Take a break I(2) G(3): temporary break from work; Brainstorm I (4) G(5) idea generation; Focus/technical work I(6) G(7) complex work tasks, such as technical engineering and design tasks; Reflect I(8) G(9) think about decisions and ideas, but not making decision or judgment; Evaluate I(10) G(11) evaluate ideas + decisions; Informal meeting (12) casual meeting of 2-6 people; Formal meeting (13) : official meeting of 2-6 persons; Lunch I(14) G(15) self-explanatory; Listen to Lecture(16) 20-50 persons ; Gym (17) any exercise activities that can be performed in gym

Note : Work tasks defined and adapted from Robinson (2012), Funke (2009), and Treffinger (1995), among others

Note : Blue cell = typical workspace type; Green cell = forest workspace type; Grey cell = cave workspace type

In terms of individual work tasks, forest space types were perceived as the most beneficial work typology for 70% of the evaluated work tasks, and at least one forest typology was within the four most preferred space types for every work task. In addition, all of the forest workspace types were preferred more than typical workspace types

for a range of work-tasks, as shown in Table 2. For instance, with regard to group brainstorm tasks, the participants' preferred the four forest spaces more than the office workspaces, as shown in column 5 of Table 2. However, none of the forest types were the highest rated typology for individual and group focus work, administrative work, formal meetings, and for conducting group evaluations, as illustrated in Table 2. Nevertheless, the forest space types, particularly the dense forest typology, were among the most preferred workspaces for these tasks as well.

Interestingly, the cave, *n5*, was not highly rated for any work task, as shown in Table 1. However, as shown in Table 2, the cave environment was still more preferred than at least three to four typical work spaces for every work-task that was evaluated. Moreover, in a number of cases, the cave was more preferred than most workspaces, such as taking a break, going to lunch, group evaluation, and individual brainstorming tasks. It is important to note that the cave image used in the survey, as shown in Figure 15, was a spatially open, public cave environment. A more private cave typology may have generated different results. Nevertheless, this result indicates that the selection of nature types was based on more than the fact that they were a form of natural environment and made occupants feel they were away from their workspace. Furthermore, these results suggest that the type, and spatial qualities, of natural environments can substantially affect occupant preference.

In regards to typical office work space types, the cellular office, open floor workspace, and conference room were the only typical work space types to be rated as the best typology for some work tasks by the participants. Furthermore, these types were also within the four most preferred space types for several work tasks, although not to the extent of the forest types. The lounge, lab, and informal open workspace were also among the four highest rated space types for several work tasks. However, it is important to note that unlike the forest workspace types, every office workspace typology, other than the lounge and private informal space typology, were consistently also among the worst rated spaces for at least several work tasks.

This may be partly due to the fact that some types were perceived by the participants to be more appropriate for either individual or group work. Indeed, the comments of the participants corroborate this possibility. For example, participants noted that they considered the conference room primarily suitable for group work. However, it should be noted that this observed perception was based on the spatial qualities of the workspace types, and the forest types provided similar scale spaces, as shown in Figures 1-15. For example, a number of participants noted that the dense forest was much like a natural version of a conference room, including the same spatial constraints and privacy levels. Nevertheless, the forest spaces were perceived as providing more useful and accommodating workspace for a broader range of individual and group tasks. Thus, these results indicate that the development and integration of natural environments into office buildings can reduce project construction and operation costs, as well as increase building space use and efficiency rates, by reducing the quantity of different spaces that need to be constructed and maintained. In other words, by providing workspaces that promote the performance of multiple work tasks, the quantity of individual workspaces for individual worktasks can be reduced for a given project.

If the nature types aren't considered in the analysis, the highest rated spaces for every work task are the cellular office, lounge, open floor, conference. In addition, the café typology was the highest rated space typology for group lunches. In this analysis, these spaces also make up the majority of the four highest rated types for conducting every work task, excluding listening to a lecture and exercising. These results suggest that the other typical workspace types are less necessary. For example, the results indicate that lounge spaces, as well as informal meeting spaces, could be substituted for a dedicated café space. However, existing research indicates that the diversity and quantity of available spatial types may also impact worker performance. (Duffy & Powell, 1997; Gruys, Munshi, & Dewett, 2011; Meusburger, 2009; Vink et al., 2008) Indeed, informal public and private meeting spaces, as well as lab space, are consistently among the second and third highest rated types for several work tasks, and may therefore provide support spaces that have an adverse effect on worker performance when absent. Hence, further research is necessary to determine the effects of various work space typology combinations and quantities on worker performance.

CONCLUSION

In general, the results suggest that knowledge workers benefit from access to a diverse array of physical workspace types. Furthermore, the results indicate that existing workspace types are not the best physical workspaces for knowledge workers to conduct a variety of key work tasks, in terms of optimizing worker performance and creativity. Indeed, forest space types were found to be more preferred than typical office workspace types for the majority of work tasks conducted by knowledge workers. Therefore, forest workspace types can be developed as adaptable work environments for a range of work tasks, which will improve worker performance and the space efficiency of office environments. By providing workspace for multiple tasks, office construction and maintenance costs can also be reduced. However, it is important to note that the perception of occupying an interior, constructed forest environment as being similar to occupying a natural environment depends on the design of the space. To this end, the results of the presented survey suggest that further research into determining effective design strategies of incorporating natural environments into office buildings could generate workspace typologies that substantially improve worker performance. Thus, the results of this survey demonstrate that the development and evaluation of innovative physical workspace types for various work tasks has considerable potential to improve worker performance, as well as office building costs.

ACKNOWLEDGEMENTS

The authors would like to thank the staff at BK City for their participation in the survey, TVVL and Van Dorp Installaties for funding this research project, as well as Matthew Davis of the University of Leeds' Socio-Technical Centre and Regina Bokel of TU Delft's Faculty of Architecture and the Built Environment, for their consultation throughout the research process

REFERENCES

- Amabile, T. M. C. R. 1999. Changes in the Work Environment for Creativity during Downsizing. *The Academy of Management Journal*, 42(6), 630-640.
- Atchley, R., Strayer, D. L., & Atchley, P. 2012. Creativity in the wild: Improving creative reasoning through immersion in natural settings. *PloS one*, 7(12).
- Axtell, C. M., Holman, D. J., Unsworth, K. L., Wall, T. D., Waterson, P. E., & Harrington, E. 2000. Shopfloor innovation: Facilitating the suggestion and implementation of ideas. *Journal of Occupational and Organizational Psychology*, 73(3), 265-285.
- Bergs, J. 2002. *Effect of healthy workplaces on well-being and productivity of office workers*. Paper presented at the International Plants for People Symposium, Floriade, Amsterdam, NL.
- Berman, M. G., Jonides, J., & Kaplan, S. 2008. The Cognitive Benefits of Interacting With Nature. *Psychological Science*, 19(12), 1207-1212.
- Davis, M. C., Leach, D. J., & Clegg, C. W. 2011. The Physical Environment of the Office: Contemporary and Emerging Issues. *INTERNATIONAL REVIEW OF INDUSTRIAL AND ORGANIZATIONAL PSYCHOLOGY*, 26, 193-238.
- Duffy, F., & Powell, K. 1997. *The new office*. London: Conran Octopus.
- Dul, J., Ceylan, C., & Jaspers, F. 2011. Knowledge workers' creativity and the role of the physical work environment. *Human Resource Management*, 50(6), 715-734.
- Fjeld, T., Bonnevie, C. 2002. *The effect of plants and artificial daylight on the well-being and health of office workers, school children, and health care personnel*. Paper presented at the International Horticultural Exhibition Floriade 2002.
- Forster, J. 2009. The Unconscious City : How Expectancies About Creative Milieus Influence Creative Performance. In Peter Meusburger, J. Funke & E. Wunder (Eds.), *Milieus of creativity : An interdisciplinary approach to spatiality of creativity* (Vol. 2). Dordrecht: Springer.
- Foster, J. J. P. I. 1995. *Carrying out investigations in psychology : methods and statistics*. Leicester, UK: BPS Books.
- Funke, J. 2009. On the Psychology of Creativity. In Peter Meusburger, J. Funke & E. Wunder (Eds.), *Milieus of creativity : An interdisciplinary approach to spatiality of creativity* (Vol. 2). Dordrecht: Springer.
- Gruys, M. L., Munshi, N. V., & Dewett, T. C. 2011. When antecedents diverge: Exploring novelty and value as dimensions of creativity. *Thinking Skills and Creativity*, 6(2), 132-137.
- Hellinga, H. I., & de Bruin-Hordijk, G. J. 2010. *Assessment of Daylight and View Quality : A Field Study in Office Buildings*. Paper presented at the International Commission on Illumination, Vienna, Austria.
- John Hesselink, Sandra van Bergen, Eric Cornelissen, Bert van Duijn, Madelon van Hooff, & Geuskens, G. 2008. *Onderzoek Met planten aan het werk*. Hoofddorp: TNO.
- Knight, C., & Haslam, S. A. 2010. The relative merits of lean, enriched, and empowered offices: an experimental examination of the impact of workspace management strategies on well-being and productivity. *Journal of Experimental psychology*, 16(2), 158-172.
- Leung, A. K., Kim, S., Polman, E., Ong, L. S., Qiu, L., Goncalo, J. A., & Sanchez-Burks, J. 2012. Embodied Metaphors and Creative "Acts". *Psychological Science*, 23(5), 502-509.
- Lohr, V. I., Pearson-Mims, C. H., & Goodwin, G. K. 1996. Interior Plants May Improve Worker Productivity and Reduce Stress in a Windowless Environment. *Journal of Environmental Horticulture*, 14(2), 97.
- Mangone, G., Kurvers, S. R., & Luscuere, P. G. 2014. Constructing thermal comfort: Investigating the effect of vegetation on indoor thermal comfort through a four season thermal comfort quasi-experiment. *Building and Environment*, 81(0), 410-426.
- Marchant, B. 1982. A look at the industry-dimensions and prospects. *American Nurseryman*, 156(10), 30-49.
- Meusburger, P. 2009. Milieus of Creativity : The Role of Place, Environments, and Spatial Contexts. In Peter Meusburger, J. Funke & E. Wunder (Eds.), *Milieus of creativity : An interdisciplinary approach to spatiality of creativity* (Vol. 2). Dordrecht: Springer.
- Nieuwenhuis, M., Knight, C., Postmes, T., & Haslam, S. A. 2014. The relative benefits of green versus lean office space: Three field experiments. *Journal of Experimental Psychology: Applied Journal of Experimental Psychology: Applied*, 20(3), 199-214.
- Robinson, M. A. 2012. How design engineers spend their time: Job content and task satisfaction. *Design Studies*(0). doi: 10.1016/j.destud.2012.03.002
- Shalley, C. E., Zhou, J., & Oldham, G. R. 2004. The Effects of Personal and Contextual Characteristics on Creativity: Where Should We Go from Here? *JOURNAL OF MANAGEMENT*, 30(6), 933-958.
- Shibata, S. S. N. 2004. Effects of an indoor plant on creative task performance and mood. *Scandinavian Journal of Psychology*, 45(5), 373-381.
- Stiles, J. V. 1995. *Human responses to interior planting*: Oxford Brookes University.
- Treffinger, D. J. 1995. Creative Problem Solving: Overview and Educational Implications. *Educational psychology review.*, 7(3), 301.
- Vink, P., Groenesteijn, L., Blok, M., & de Korte, E. 2008. *Office interior design effects on meetings*. Paper presented at the 9th International Congress of Physiological Anthropology, Delft, The Netherlands.

Core-housing and collaborative architecture: Learning from Dandora

Glen Wash Ivanovic¹, Junko Tamura²

¹Xi'an Jiaotong-Liverpool University, Suzhou, China

²National University of Singapore, Singapore

ABSTRACT: This paper introduces a case study which aims to record and reevaluate the current state of the emblematic sites-and-services project of Dandora, located in Nairobi, Kenya. Sites-and-services schemes are a well-known set of principles and steps aimed to provide housing to low-income people in developing countries. These projects were crucial in pioneering the inclusion of concepts like self-help and core-housing as an alternative to traditional social housing projects. Today, many of these projects are considered unsuccessful. They were actively revisited and reevaluated soon after their execution in the 70s and early 80s, and it is generally agreed that, because of many and complex reasons, sites-and-services projects had a number of shortcomings during their implementation. However, most of these reevaluations were done soon after the projects were implemented, and their consolidation process over the years has received little attention. For this case study, we revisited a specific area of Dandora which is regarded as the one with the best environmental quality by both local authorities and residents. We surveyed and recorded the actual state of the self-built houses and the resulted typologies, while also interviewing the current tenants. The analysis shows that the involvement of the tenants in the shaping of the Dandora project has reached unforeseen extents on both architectural and communal levels. Finally, the paper discusses the implications of these typologies and their possible applications in social housing and collaborative design.

KEYWORDS: Core-housing, Collaborative Design, Informal Settlements, Sites-and-services.

INTRODUCTION

The quality of human settlements is a prerequisite for the full satisfaction of the most basic human needs and rights. The scale of the problem caused by the world population growth requires joint efforts and cooperation in finding solutions consistent enough to be applied in several developing countries, while also being flexible enough for adapting to the particular social, economic, environmental and cultural reality of those countries. One of the first responses to this problem were the sites-and-services projects, widely implemented by governments and agencies during 1970s and 1980s, when the approach became a paradigm for tackling the slums and squatters problem. Sites-and-services projects were also significantly funded and promoted by the World Bank, providing financial and technical assistance to local governments for its implementation. Some of these projects incorporated the idea of the core-house; a minimum house unit providing basic services which the tenants were supposed to improve and expand over time, promoting self-help and shared responsibilities between governments and tenants.

Theoretically, the sites-and-services approach was very promising, yet for a number of complex reasons, often including low investment recovery and the production of low quality urban environments, today many of these projects are considered unsuccessful. However, there is also agreement that most of the evaluations of these projects were done shortly after their implementation, without taking into account their consolidation and evolution over the years. So how these projects have changed and consolidated over time? In order to explore this question, we decided to visit the sites-and-services project of Dandora Phase one, surveying some of the resulted houses and interviewing the tenants in order to understand the current state of the project.

1.0 SITES AND SERVICES

Attempts for dealing with the housing problem on a global scale notably increased since the end of the Second World War (Basset and Harvey, 1997). At the beginning the problem was almost entirely confronted by local governmental agencies in developing countries. Although some of these agencies were occasionally assisted and supported by international institutions most of their efforts were independent from each other in their implementation, focalized in particular problems at a local scale. Conceptually, however, they shared a common origin: the sites-and-services projects. The sites-and-services scheme is generally understood as a subdivision and preparation of urban land for residential buildings and the provision of public utilities and community facilities (Soni, 1982). Besides this core idea, there is little agreement in what the sites-and-services concept actually means. The World Bank (1974) noticed that defining design standards for the projects to follow is an extremely difficult task, since they are hard to rationalize without considering a number of specific local variables like income level, local political system, transportation, and so on. Despite this, there is consensus that a building plot providing basic infrastructure is the most essential requirement for a sites-and-services project. From this initial idea, projects may evolve into one of two different approaches to the scheme. The first one emphasizes the participation of the households in the

process of construction of the house, yet not in its design, which is prepared and provided by a housing agency. The second one is focused on the freedom to build, where the householder is in control of the construction and design process of the house, being able to modify the scheme according to his/her needs, resources and abilities (Yap, 1998). In both cases, the affordability and flexibility of the basic building plot are essential for the rest of the process to progress successfully.

The first recorded sites-and-services schemes were executed during the 1940s and 1950s in developing countries like Chile and Kenya without significant external assistance (Mayo and Gross, 1987). This situation changed during the late 1960s and early 1970s, when international agencies became more and more involved in the development of site-and-services projects, reaching a significant global implementation of these schemes. A survey by the World Bank (1972) revealed that from the mid-1950s until 1972, around 770.000 service plots were implemented for occupation in more than 20 countries. A significant number of these plots were financed by the International Bank for Reconstruction and Development (IBDR). After the Vancouver Declaration these numbers increased drastically. In 1984 alone, the World Bank initiated around sixty-eight sites-and-services projects for the benefit of more than 25.000 households (Mayo and Gross, 1987).

1.1. Core-housing and sites-and-services

The idea of self-building generally implies a territorial claim within an urban area, where the settlers secure land which they do not own by gradually improving and expanding their houses to the point that they cannot longer be considered temporary shelters. These expansions take place as the families are able to save money for their execution, which often results in varied lapses of time between periods of construction. Abrams (1964) was the first in turning this spontaneous way of building into a framework for self-aided housing. He introduced the idea of an initial "core" provided with basic services in which the tenants could live while they expanded their houses. In theory, the introduction of the core-house promised great adaptability and affordability: depending on the income of the country the original core could include one or more rooms and allow both horizontal and vertical expansions. Also, the quality of the resultant houses could potentially be comparable to that of the fully built ones but being considerably cheaper and easier to implement. Local governments rapidly adopted this approach because offered several advantages in comparison to providing fully-built social houses, like low initial investment and involvement just to the point where they could still keep control of services, land tenure and location of the schemes (Napier 2002). During the 1970s the World Bank supported the core-house approach in many of its sponsored sites-and-services projects, with examples in Colombia, El Salvador, Mexico, Tanzania, Kenya and many others. However, the results of the implemented projects were not the expected ones, and since the mid-1980s both sites-and-services projects and the use of the core-house have received wide criticism, arguing difficulties in its implementation, bureaucratic procedures and political instability, a lack of proper design, poor construction standards and, above all, very low recovery of the initial investment and failure in securing land ownership for the initial tenures. The basic assumption was that the promise of land ownership will be the main incentive for the beneficiary to pay back the initial subsidies. This was not the case, with most of the sites-and-services projects registering low cost recovery. There are no single reasons for explaining this and they vary from project to project. High cost of the land trespassed to the tenants, inconvenient location of the schemes, uncertain security of land tenure and new expenses for the residents (transport, electricity and water) resulted in many of the beneficiaries preferring to sell or rent the houses in order to pay back loans, proving that the assumption of ownership as the main motivation for the tenants to commit and produce quality houses was not fulfilled in most of the cases (Napier, 2002).

Sites-and-services schemes were subject of many evaluation reports shortly after their implementation during the 1970s and 1980s, usually pointing out the already mentioned shortcomings. The same applies to the concept of the core-house. However, the criteria for evaluating these projects were mostly focused in its initial implementation, and not on the consolidation of the houses over time. These projects were among the first attempts of self-help policies and core housing; the learning by doing stage of the concept. Long-term evaluations of these projects are scarce and there are still many lessons to be learned from them, especially from an architectural perspective. There are a number of sites-and-services neighborhoods today, often indistinguishable from regular neighborhoods, and the basic concept of the core-house can be found in modern approaches which are considered successful, like the Elemental projects (Aravena and Iacobelli, 2012).

2.0. CASE STUDY IN THE DANDORA COMMUNITY

The city of Nairobi has been struggling with informal settlements since the independence of Kenya in 1963. Most of the slums in Nairobi today have their origins in the early 1960s. The resiliency of the slums is explained by the tremendous population growth that Nairobi keeps experiencing. From the 1906 to 2009 the population of Nairobi has grown from 11.500 to 3.1 million people. More than half of the city's population lives in informal settlements which altogether occupy only a 5% of Nairobi's residential area (Mitullah, 2003). Between 1970 and 1978 the Kenyan government started a program which provided more than 40.000 units

of social houses. More than 50% of the built houses came from sites-and-services schemes, and more than half of those were, either partly or fully, financially supported by the World Bank (UNCHS, 1987). The Dandora sites-and-services project was started in 1975. Located about 10km to the east of Nairobi's city centre, it was the first project of this kind in Nairobi sponsored by the World Bank, which specified guidelines to follow in exchange for the loan; the preparation and servicing of 6.000 plots plus supporting infrastructure. It is estimated that the Dandora project accommodated around 12.000 households, roughly a 13% of the housing needs at that period, becoming a distinguishable and emblematic project within the urban fabric of Nairobi.

2.1. Identifying the community

There is precedent research which recorded the resultant typologies of the Dandora project shortly after it was first implemented, yet the surveyed typologies were sparse all over the totality of the project, aiming to obtain an average evaluation of it (Soni, 1982). For this particular case study we decided that it was more appropriate to record houses which were contiguous to each other, so we could understand the relationship between that resulted schemes and its community. Also, we needed to make sure that the residents were open to having us intruding in their private lives. This is not difficult to achieve when looking for individual plots in the whole of Dandora. However, when looking for several plots contiguous to each other, with more than one family living in each plot, this was a rather complex task. Finally, the majority of the residents of the selected plots welcomed us to their houses, and we were able to undertake the research with relative ease.

2.2. Case study: execution

During three days we visited and measured fifteen plots (Fig.1), recording the current typologies. The main aim when doing this was to understand how closely the tenants have been following the suggested design guidelines proposed by the local authorities, the quality of construction achieved in the self-built houses, the number of people living in them and finally, progression rate of the different expansions done over time. Also, we carried out interviews to tenants in each plot, aiming to register information about gender, ownership, years working in the city and their general opinion about the schemes.

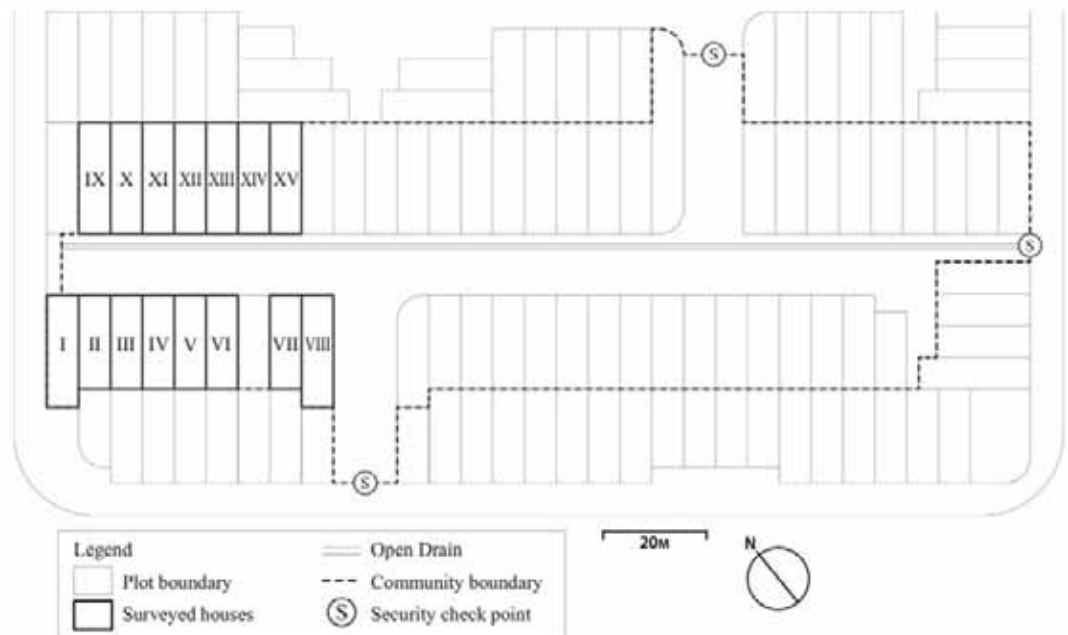

Figure 1: Plan showing the surveyed street and houses in the Dandora community.

2.3. Case study: results

One of the first noticeable characteristic of the surveyed area was that neighbors organized themselves for turning their streets into a gated community. During the day, access to the community is public, yet during the night gates are closed and kept by paid guards. The closing of the street was organized and financed by the residents so they could keep the community safe at night (Fig.1). The second observable fact was that all the rooms within a given plot are occupied by different tenants, and in many cases each room sheltered one full family. While this situation was up to some degree accepted in the initial project, understood as an extra source of income for the original owners, the extents of the overpopulation in each plot is beyond what

was expected (Fig.3) resulting in unavoidable tensions among the tenants. This situation, however, is observable in the whole of Nairobi and it is not unique to Dandora. Because of this, each plot can be understood as a micro-neighborhood, where the relationships and level of agreements between neighbors had a direct correlation with the quality and maintenance of the common public spaces (yards) inside each plot. The second characteristic is that each of the plots still keeps the core-room (Fig. 2), yet none of them uses it as common kitchen, as initially planned. Instead, they have become rooms for renting. The tenants usually cook either in the yards or inside their rooms in especial areas which they have prepared as kitchens (using liquefied gas stoves). It is difficult to conclude if this is because the original common kitchens have been rented as rooms or if the residents prefer to do their cooking separately and in private.

Also, the original common wet-core (W.C and shower) has been kept in all the typologies. This area is clearly a main encounter point for the tenants. Again, the quality and maintenance of the wet-core varies greatly from plot to plot, becoming a sign of the level of organization between neighbors. It was also interesting to see that, when expanding the houses, most the schemes on the north side of the street closely followed the design guidelines of the “upgraded state” suggested by the local government, although a few of them showed patterns of further expansions in the front and middle of the plot, generating a narrow corridor which created a separation between yards, resulting in one “public yard” (occasionally opened to the street) and an interior, more private yard (Fig. 2: houses IX, X, XI and XV). In the south side of the street the situation was different, where some of the plot’s boundaries have been modified, taking portions from other plots (houses I and VIII). Some of these plots have reached a point in which more horizontal expansions are no longer possible (houses VI and VIII). It was also noticeable that of the tenants have rented two rooms for themselves and combined them into one. Many expansions were executed solely for this purpose (houses I, III, IV, IX, X, IX).

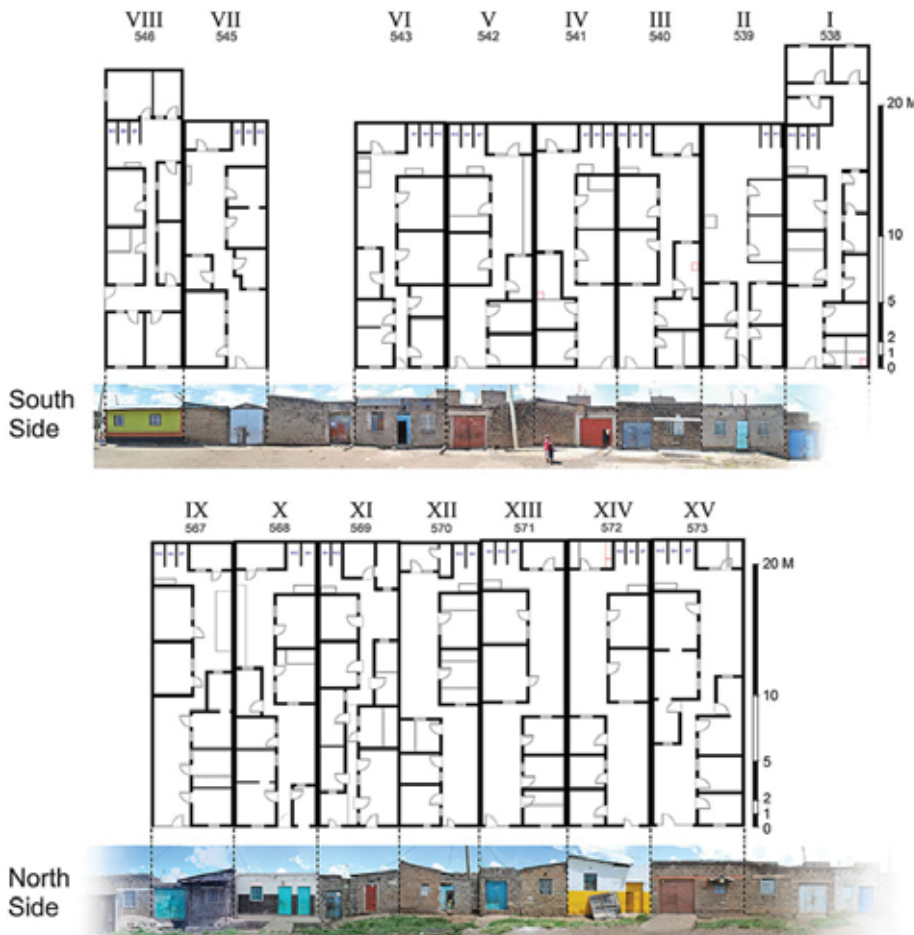

Figure 2: Resultant typologies of the surveyed street.

Most of the tenants also created soft partitions to their room, using curtains, light walls or vertical maximization of space. There was a clear difference between the qualities of construction in some of the schemes. These changes in quality had no correlation with the date of construction since some of the later

expansions are of lower quality than the initial ones. This contradicts the assumption that as the tenants become more experienced the quality of the schemes would improve. The changes of quality could be attributed to the level of investment, but in many cases this was explained solely on the skills and level of commitment of the tenants.



Figure 3: Sample typology showing density of occupation and the current conditions of the plot.

We also interviewed 34 tenants from different plots with the aim of understanding their evaluation of the project and how this one compares with surveys done soon after Dandora was first populated. In previous surveys a significant number of the tenants were originally from the country side, coming to the city for economic reasons, expressing their desire of going back to their villages after retirement. For those tenants, migration to the cities was more of a need rather than a choice, and this translated into an absence of long-lasting commitment with their houses in the city. Interestingly, this situation has changed. Around 70% of the current residents also have rural origins, yet most of them expressed their desire to stay in the city (their ages range from 20 to 60 years old). Almost 90% of the residents have a very positive evaluation of the houses and the community. From those, 60% stated that they have no intentions of moving elsewhere and they would like to stay in Dandora. From the 34 residents, only four of them are the original owners. The other 30 residents are renting their rooms.

CONCLUSIONS

The shortcomings of the Dandora project are evident when it is evaluated from a housing policy perspective, mostly due to its low recovery of initial investment. While this is indeed a strong argument against the project, there are positive outcomes regarding the core-housing approach and the quality of the environment which it has produced. At first sight the resultant neighborhoods and living conditions may indicate that these projects were unsuccessful, yet this may be because unrealistic expectations for the project rather than mistakes in its conception. Many of these shortcomings (like overpopulation of the plots) are observable in several areas of Nairobi, and Dandora offers significant pros (like adaptability and flexibility) when compared with projects which were fully built by the government, proving that core-housing can be a viable alternative. The residents were positive in their evaluation of the scheme. Their reasons are strongly linked to a sense of community and safety developed in the surveyed street, but also with a new ease with urban life. It is difficult to draw a clear correlation between the design of the scheme and the origin and evolution of these community ties, but it is safe to say that the scheme is not acting against them. There is also something to say about the assumption of land ownership as the main motivation for the residents to improve their houses. Most of the interviewed residents are not owners, but renters and yet they are actively involved in permanent improvements to both their rooms and the open spaces of the plot. This is a reminder that “to own” is not the same as “to belong”. These are of course not easy concepts to incorporate in future guidelines for housing policies, but revisions to successful sites-and-services schemes can provide insights in this process. More methodologies for analyzing the correlation between the schemes and the generation of communities are needed, and that will be one of the focuses for future developments of this research. For now, it is worth noticing that sometimes, in order to open and fully create a sense of neighborhood it is necessary the creation of clear boundaries. This is a very architectural thing to do: the definition of boundaries as a mean to open possibilities and choices, rather than for creating restrictions and limitations. This is what the people of the studied community have done: defining boundaries for their community so they could open it to a new level, suggesting that what this project needs is not necessarily a budget increment or the definition of standards, but better architecture.

REFERENCES

- Abrams, Charles. 1964. *Housing in the Modern World*. London: Faber and Faber.
- Aravena, Alejandro. Iacobelli, Andres. 2012. *Elemental: Incremental Housing and Participatory Design Manual*. Hatje Cantz Verlag GmbH & Co. KG, München, Germany.
- Bassett, Ellen M. Jacobs, Harvey M. 1997. *Community-based tenure reform in urban Africa: the community land trust experiment in Voi, Kenya*. Land Use Policy Vol. 14, No. 3: 215-229
- Mayo, Stephen K. Gross, David J. 1987. *Sites and Services—and Subsidies: The Economics of Low-Cost Housing in Developing Countries*. The World Bank Economic Review Vol. 1 No. 2: 301-335.
- Mitullah, Winnie. 2003. *Understanding Slums: Case Studies for the Global Report on Human Settlements, 2003 – The Case of Nairobi, Kenya*. UN-Habitat.
- Mutisya, Emmanuel. Yarime, Masaru. 2011. *Understanding the Grassroots Dynamics of Slums in Nairobi: The Dilemma of Kibera Informal Settlements*. International Transaction Journal of Engineering, Management, & Applied Sciences & Technologies Vol.2, No. 2: 197-213
- Napier, Mark. 2002. *Core housing, enablement and urban poverty: the consolidation paths of households living in two South African settlements*. Thesis (Ph.D.) Newcastle University <http://hdl.handle.net/10443/2052>
- Soni, Praful N. 1982. *On Self-Help in a Site and Services Project in Kenya*. Thesis (M.Arch.As) Massachusetts Institute of Technology, <http://hdl.handle.net/1721.1/78833>
- United Nations General Assembly (UNGA). *Habitat: United Nations Conference on Human Settlements*, 16 December 1976. A/RES/31/109
- United Nations Centre for Human Settlements (UNCHS), Habitat. 1984. *Sites and Service Schemes: The Scope for Community Participation - Training Module*.
- United Nations Centre for Human Settlements (UNCHS). Habitat. 1987. *Case study of sites and services schemes in Kenya: Lessons from Dandora and Thika*.
- World Bank. 1972. *Urbanization: sector working paper*. World Bank, Washington, D.C
- World Bank. 1974. *Sites and Services Projects*. World Bank, Washington, D.C
- World Bank. 1975. *Kenya Site and Service Project*. World Bank, Washington, D.C
- Yap, Kioe S. 1998. *Sites-and-Services Scheme*. The Encyclopedia of Housing, 540-542. Sage Publications, Thousand Oaks, CA.

A semi-immersive virtual environment preference study of four interior architectural geometries

Hannah Hobbs¹, Kurt Hunker¹, Vuslat Demircay¹, Tiffany Rodriguez¹, Rajaa Issa¹

¹NewSchool of Architecture + Design, San Diego, CA

ABSTRACT: As technology advances, architectural design methodology changes in response. Today's use of advanced computers and digital fabrication often gives rise to non-rectilinear buildings. This pilot study addresses the appropriateness of the resultant architectural forms, and provides a novel process for examining how new forms affect inhabitants' wellbeing.

The present study tested preference levels of four different architectural geometries in an innovative semi-immersive virtual environment ("CAVEtte"), designed and built by the author and a collaborator. All digitally modeled designs were of four built Maggie's Centres: (curved) Southwest Wales by the late Kisho Kurokawa; {mixed} Aberdeen by Snohetta; [rectilinear] Cheltenham by MJP Architects; and <angled> Fife by Zaha Hadid. Rendered walk-through videos of the models were created in Rhinoceros from available plans, sections, elevations, and photographs. Models were generated without textures, and furniture and walls were given the same neutral color throughout.

65 participants (19 females, 46 males) at NewSchool of Architecture + Design participated in Experiment 1, watching four walk-through videos, one of each building, in a randomly selected order. Participants filled out a subjective survey, which helped define "preference" using six pairs of bipolar adjectives of semantic differentials with an added "neutral" between each pair. The word sets were: 1) pleasant, unpleasant; 2) exciting, depressing; 3) relaxing, stressful; 4) friendly, unfriendly; 5) like, dislike; 6) beautiful, ugly. The first word of each set indicated positive preference, while the last word indicated negative preference.

While findings are consistent with previous contour-focused studies, there were some intriguing novel results when the data were parsed demographically by age, gender, education level, designers versus non-designers, and years in the profession, demonstrating that preference was modulated by these factors. Further, the study demonstrates the great potential for architects that a virtual environment can have for judging how designs are perceived by clients and the public.

KEYWORDS: Preference Study, Immersive Virtual Environment

1.0 INTRODUCTION

1.1. Relevance of the Study

In our modern society, studies show we spend a majority of our lives indoors (Juster, Ono, and Stafford, 2004; Klepeis, et al., 2001; Ott, 1989) giving impetus to examine how the built environment affects us. Additionally, architects have been designing buildings to evoke a physiological, spiritual and emotional response without the exacting study of the effect buildings have on the nervous system. As "humans often respond to architectural settings with emotions that are subconscious and sometimes expressed as feelings [they] also may respond to certain settings by changes in behavior" (Eberhard, 2007, p. 68). Neuroscientist Dr. Fred Gage, explained:

...while the brain controls our behavior and genes control the blueprint for design and structure of the brain, the environment can modulate the function of genes and, ultimately, the structure of our brain. Changes in the environment change the brain, and therefore they change our behavior. In planning the environments in which we live, architectural design changes our brain and our behavior. (Gage, 2003)

Furthermore, brains change due to the enrichment and stimulation of the environment (Van Praag, Kempermann, and Gage, 2000; Rosenzweig, 1979; Renner and Rosenzweig, 1987). Enriched environments are "a combination of complex inanimate and social stimulation" (Rosenzweig, et al, 1978 p.191), and have "been shown to enhance memory function in various learning tasks" (Renner and Rosenzweig, 1987). Currently neuroscientists "...are trying to separate the role of visual interactions with an environment from the role of physical interactions" (Tuma, 2006).

Critical and theoretical debate within the architectural and neuroscientific fields show the importance of architectural form as it relates to physical and mental health. "People constantly make snap judgments about objects encountered in the environment. Such rapid judgments must be based on the physical properties of the targets, but the nature of these properties is yet unknown" (Bar and Neta, 2006). Bar and Neta's 2006 study found higher preference for emotionally neutral objects with curved contours over their sharp-angled counterpart. In 2007, Bar and Neta's functional magnetic resonance imaging (fMRI) study showed more activation in the amygdala (known to be associated with fear and general arousal) when subjects viewed sharp-angled contour objects over their curved counterpart. While the 2006 and 2007 studies tested emotionally neutral objects, Leder, Tinio and Bar (2011) tested objects with both positive (e.g. cake, chocolate) and negative (e.g. snake, bomb) emotional value. The authors "found that people indeed preferred the curved version of the object to the sharp version of the same object, but only if the objects were neutral or positive in emotional valence." Their study suggested little preference between emotionally negative curved objects to their angled pairs.

Vartanian et al. (2013) tested three architectural variables (curved versus rectilinear contours, openness, and ceiling height) in an fMRI scanner in two runs (beauty-judgment and approach-avoidance); the results suggested "participants were more likely to judge curvilinear than rectilinear spaces as beautiful" and that "judgment of beauty for curvilinear spaces is underpinned by emotion and reward." The authors inferred their results to "suggest that in architecture, sharp contour might not serve as an early warning signal for potential danger as it might elsewhere." Perhaps we are used to angles in architecture, and therefore we do not see them as threatening. In support, "people living in a highly industrialized environments perceive angles and straight edges differently from people who live in environments without square, manufactured structures" (Jansen-Osmann and Heil, 2007; Allport and Pettigrew, 1957). Lastly, Madani Nejad's 2007 study ranked two modified interior residential views where the "architectural forms gradually changed from fully rectilinear to fully curvilinear" in a card-sorting task. The results "indicate that curvilinear form tends to make observers feel safer and perceive the space as more private," and "less stressful."

1.2. Introduction to the Study

Technological advances in architecture impact the design and building process, from computer technology to building materials and digital fabrication, which promote the design of non-rectilinear buildings. It is important that neuroscientists and architects collaborate to understand how both rectilinear and non-rectilinear architectural forms affect us at all levels.

This study tests four different interior architectural contours at a near one-to-one scale in a semi-immersive virtual environment. The architectures studied are of four built "Maggie's Centres" located around the United Kingdom designed by internationally acclaimed architects who were all given the same architectural brief. The four buildings selected for this study differed in architectural form ranging from curves to a mix of curves and angles to all angles.

Based on previous architectonic and neuroscientific studies showing a statistical significance of preference for, and less amygdala activation of, curved contour objects versus sharp-angled contour objects, this study postulates preference to be higher for curved architectural interior environments over the other geometric architectural interior environments.

2.0. METHODS

2.1. Subject Selection

Studio instructors encouraged at least two of their students to participate voluntarily (with no compensation) in this study. In addition to architecture students, students and faculty from the Construction Management and Interior Design schools participated to assure a range of disciplines to determine if academic training affected preference. All participants signed a release form to participate and filled out a background questionnaire used in data analysis for demographics analysis.

The Primary Investigator (PI) sought out an additional 20 participants for a one-day retest (Experiment 2). The additional participants had not been exposed to the first experiment and consisted of a mix of faculty, staff and students from all departments of the school.

2.2. “CAVEtte” and the testing environment

The semi-immersive virtual environment was designed and built on a limited budget with help from an outside colleague, Kevin Sullivan, M.Arch, based on previous immersive setups found on YouTube (Fig. 1). Testing was conducted at NewSchool of Architecture and Design (NSAD) (Fig. 2).

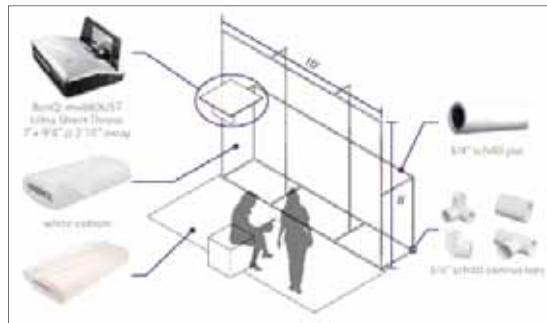

Figure 1: Semi-Immersive virtual environment.

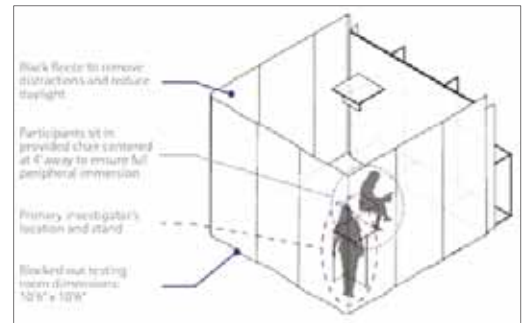

Figure 2: CAVEtte.

2.3. Maggie's Centres

At the time of the study there were fifteen Maggie's Centres located around the United Kingdom. Each of the Centre's architects applied their own individual approach, resulting in design variations between the centers.

All fifteen centers were analyzed by looking at available drawings, renderings and photographs. The Centres were vetted with author members in a three-stage process to determine contour majority. As four categories emerged (curved, mix of curves and right angles, fully rectilinear, and sharp angled) the selected buildings were decided: (curved) Southwest Wales by the late Kisho Kurokawa; {mixed} Aberdeen by Snohetta; [rectilinear] Cheltenham by MJP Architects; and <angled> Fife by Zaha Hadid.

Referencing both the neuroscientific and architectonic studies discussed above, potential irrelevant distractions were eliminated by: 1) removing all extraneous furniture; 2) removing color and materiality from the models, thus creating a similar neutral tone across all modeled buildings; and 3) making slight adjustments to each design to enhance the experience of being in each contour category (Fig. 3).



Figure 3: Selected Maggie's Centres (actual | testing environment).

2.4. Variables

The independent variables in this study were the predesigned rendered walk-through videos of each of the four selected built Maggie's Centres shown in random order and documented. The difference between the first and second immersive experiment was the velocity of the walk-through and thus the duration of each video and session.

The dependent variable was the measure of preference of each interior environment. Preference was defined by using seven sets of bipolar adjectives of semantic differentials with an added “neutral” between each bipolar word. The words chosen for each set were adopted from Hesselgren (1987) as referenced in Madani Nejad’s 2007 Ph.D. study. The word sets were: 1) pleasant, unpleasant; 2) exciting, depressing; 3) relaxing, stressful; 4) friendly, unfriendly; 5) like, dislike; 6) beautiful, ugly; and 7) unique, typical. For sets one through six, positive preference is noted as the first set of words, while negative preference is the last word. Due to time constraints, responses to the seventh set were not used in data analysis.

2.5. Testing methodology

One participant at a time entered the testing room and sat facing the screen in the provided chair. The PI informed each participant of the testing protocol before beginning the experiment. To ensure the order of video sequencing of contours did not bias results, a list of the 24 possible variations was created and subjects were given a random number associated with video sequence file. Video sequence was noted on each subjective survey for data analysis.

3.0 DATA ANALYSIS

3.1. Overview

For Immersive Experiments 1 and 2, the data represents totals calculated from the six word choice preference sets. The words were given a rank of 1 for negative preference, 2 for neutral preference, and 3 for positive preference; the higher the mean, the higher the preference, and vice-versa.

80 students, faculty and staff from NSAD participated in a multi-week testing of Immersive Experiment 1. The data was reviewed, and concerns regarding validity and limitations of the study led to a second test – Experiment 2 – where an additional 20 students, faculty and staff participated in a one-day retrieval. After conducting an Analysis of Variance (ANOVA) there was no statistical difference of preference rating between the first and second experiment for curved, mixed and angled. And while there was a statistical difference between the two immersive experiments for the rectilinear building, overall Immersive Experiment 2 supports data collected from Immersive Experiment 1 and suggests neither speed nor video duration seemed to play a factor in altering data (Table 1). Therefore, the following results are based on Immersive Experiment 1.

15 subject responses were removed from the data analysis from Immersive Experiment 1 due to full or partial knowledge of the study; the following results from Immersive Experiment 1 were based on 65 out of the 80 subjects tested (also reflected in the ANOVA) (Fig. 4).

Anova: Single Factor					
SUMMARY					
Groups	Count	Sum	Average	Variance	P-value
CurvedPref-Exp1	65	162.5	2.5	0.19618056	0.13349769
CurvedPref-Exp2	20	53.1666667	2.658333333	0.06864035	
SUMMARY					
Groups	Count	Sum	Average	Variance	P-value
MixedPref-Exp1	65	142.5	2.19230769	0.29707532	0.63650088
MixedPref-Exp2	20	45.1666667	2.258333333	0.29378655	
SUMMARY					
Groups	Count	Sum	Average	Variance	P-value
RectilinearPref-Exp1	65	137.6	2.11692308	0.27212233	0.0363237
RectilinearPref-Exp2	20	47.83333333	2.39166667	0.18501462	
SUMMARY					
Groups	Count	Sum	Average	Variance	P-value
AngledPref-Exp1	65	135.466667	2.08410256	0.25472598	0.17427121
AngledPref-Exp2	20	38.1666667	1.908333333	0.24115497	

Table 1: ANOVA Single Factor - Immersive Experiments 1 and 2

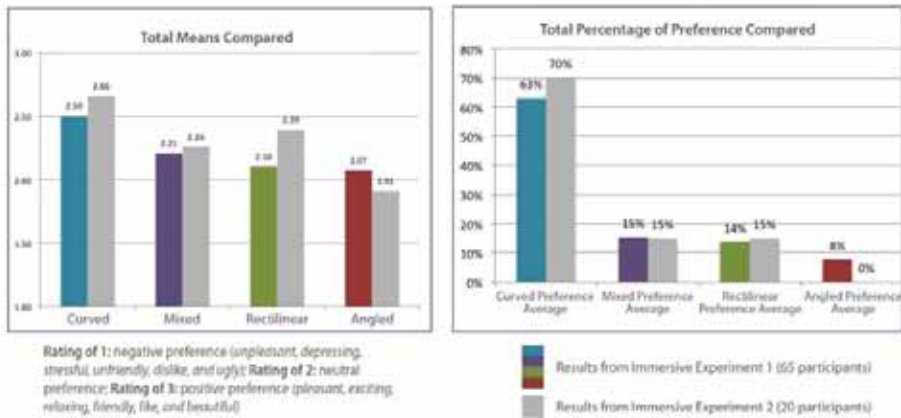

Figure 4: Immersive experiment 1 vs. 2.

3.2. Immersive Experiment 1 by demographics

Gender: While preference ratings differed by gender in this study, with females showing a stronger preference than males for curved geometries, the sample size was too small to draw definitive conclusions, pointing to an area for further study.

Designers vs. Non-Designers. Data shows a similarity between those who have studied (or are currently studying) design, versus those who have not. This information was extracted from the background questionnaire when looking at degree studied (whether previously, or currently). “Designer” was selected when a participant mentioned architecture, interior design, digital media art, art or marketing. “Non-designer” was selected when construction management, counseling, LGBT studies, library science, or education was listed. Additionally, this was matched against years noted of participant’s “studying design.” The thought is to see if design-minded people are more sensitive to the different environments. Note, however, that non-designers in this study work around designers, possibly skewing the results, a potential limitation of the study. Further research is warranted.

The results show higher preference for curved and rectilinear buildings by designers versus non-designers, and a slight negative preference for the mixed and angled building. It is likely that designers are not only more sensitive to buildings (as mentioned above), but they might have been more sensitive to the overall process (and limitations) of the study, thus affecting their experiential results.

Graduates vs. Undergraduates. Participants were placed into two categories, student or faculty/staff; this demographic paring looks at 54 of the 65 participants, current NSAD students who did not know about the study. It shows undergraduate students prefer the more “unconventional” building designs over the rectilinear building the graduate students prefer. This could be due to education level, or excitability level among younger students, responding to novel designs that differ from the norm.

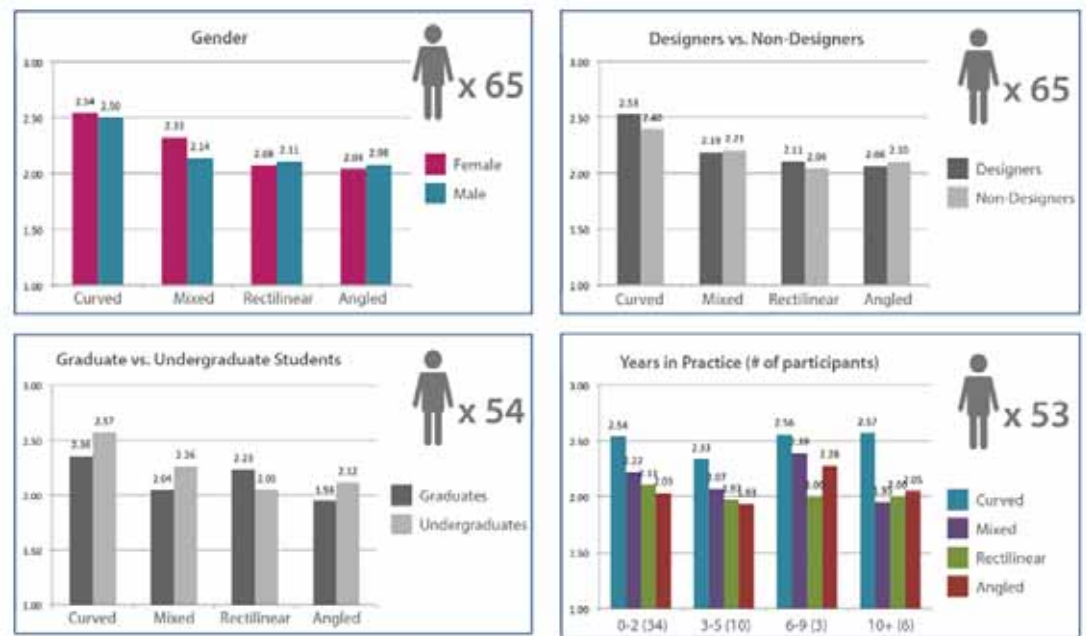

Figure 5: Results by selective demographics

Years in Practice. The term “practice” was intended to imply architecture or the related field (design, interior design, and construction management). Those who marked their years in practice, and practice was not inferred as architecture or the related fields, were given a 0-2 category. 12 subjects did not fill in this information, and were therefore taken out of the analysis.

Preference for the curved building was significantly higher among most participants regardless of years in practice. However, those who marked 6-9 years show a higher preference for the mixed and angled building compared with others. Participants with 10+ years in practice preferred the angled building slightly more than the rectilinear or the mixed.

3.3. Word choice across all shapes

Data analysis compared totals from each word choice per building design to see the overall differences in preference based on the six bipolar adjectives. It is important to see how participants viewed the curved building over the other three buildings. With the exception of “exciting-depressing” and “beautiful-ugly” most ratings were significantly higher, with the latter still showing a higher preference.

In all but the rectilinear building results, a strong positive or negative pull towards “exciting-depressing” is matched by an opposite pull towards “relaxing-stressful.” A potential limitation could be the order of the word choices, for choosing either relaxing, neutral or stressful, each participant could have been biased towards one word or another based on what they chose for the previous word set: “exciting-depressing.”

Curved. The final data, parsed by demographics, showed an overall higher preference for the curved building. Most participants felt the curved building was pleasant, relaxing and friendly. Interestingly, when deciding whether the curved building was either exciting or depressing, overall participants viewed it more closely as neutral – lacking strong positive or negative opinion. Additionally, the “beautiful-ugly” word set tended toward an overall neutral opinion. **Mixed.** While the preference ratings for the mixed design are not as high as the curved buildings, the mixed building preference is still slightly higher than neutral. Note: looking at the word set “relaxing-stressful,” overall participants viewed this building as more stressful – though just below the neutral line. A potential reason could be the limitations in the walk-through video of the unnatural feel of moving up and down the stairs; additionally no other video used stairs. **Rectilinear.** While there is an overall neutral preference towards the rectilinear building, participants rated the rectilinear building slightly more pleasant than unpleasant. Note that none of the word choices drop below a “neutral” rating of 2. **Angled.** Participants viewed the angled building with less preference. While both the overall “pleasant-unpleasant” and “friendly-unfriendly” ratings are slightly below “neutral,” the rating was slightly higher than neutral towards “like” and “beautiful.” Furthermore, the higher response of “exciting” the stronger the response towards “stressful.” Similarly to the mixed building response, the increase in excitability is not always synonymous with pleasant or relaxing.

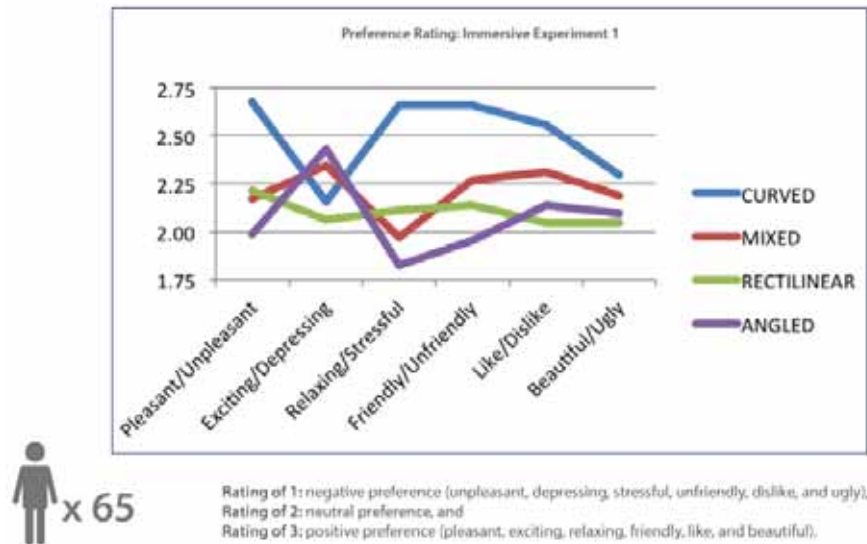

Figure 6: Preference rating: Immersive experiment 1.

4.0 DISCUSSION

4.1. Observations

As findings from this study are consistent with aforementioned studies, key observations and limitations include the following. 1) Preference could have been made on having a shorter path through the building and not experiencing a majority of the building; also alleviating potential inconsistencies across the study. 2) The data presented above shows a neutral preference rating for the rectilinear building across the bipolar word choices. Assuming that in our modern society we are accustomed to rectilinear forms within

architecture, we therefore have no strong positive or negative preference towards them, and that right-angled architecture is not always a bad first choice, or default form. 3) Evidence in this study suggests that adding curves into the design might elicit for a more preferred experience, and should be strongly considered by architects within their design.

4.2. Limitations and future studies

Limitations of the study include: conducting an architectural scientific study as a nine-month Master of Architecture thesis; employing the CAVEtte versus a fully immersive environment; velocity of walk-through videos for Immersive Experiment 1; inconsistent lengths of the walk-through paths; and traversing vertically via stairs in only the {mixed} building.

Areas for future studies include: increasing the sample size in a fully immersive environment; controlling for velocity of walk-through videos; and standardizing the length and consistency of the walk-through paths.

4.3. Summary

The findings presented in this study show the overall preference rating was higher for the curved environment in the immersive experiments. Furthermore, as curvature decreased and angles increased, preference drops.

This study was not only about testing preference for curves, mix of curves and 90-degree angles, only 90-degree angles, or acute angles within architecture, but also about testing the validity of utilizing immersive technology in the architectural design process. When comparing the results from this study to the previous neuroscientific and architectonic studies, this study exhibits success and impetus to incorporate immersive technology not only into the architectural design process, but also when researching the effects of architecture. The use of immersive studies have proven to be a powerful means of obtaining feedback on designs and could be used productively by architects before committing their designs to physical construction.

ACKNOWLEDGEMENTS

I would like to thank and acknowledge many advisors and professionals in the architectural and neuroscience disciplines who supported this study. Dr. Bradley Walters who responded positively when first approached and who helped narrow the topic into a manageable focused study. Dr. Upali Nanda provided insight and additional relevant publications to this topic along with encouragement of its relevancy to architecture today. Jorge Ozorno for his creative ideas and support. Will Hobbs for editing and technical support. NewSchool of Architecture + Design for the approval to pursue this as a thesis project, use of the facilities, and overall institutional support. I would like to thank the Academy of Neuroscience for Architecture (ANFA) for their constant support and encouragement of this cross-disciplinary field.

This study was conducted by the Primary Investigator, Hannah Hobbs, as part of her Master of Architecture Thesis completed over the course of one school year. The additional authors were Thesis Committee members participating and guiding throughout the year.

REFERENCES

- Allport, G., & Pettigrew, T. 1957. Cultural Influence on the Perception of Movement: The Trapezoidal Illusion Among the Zulus. *Journal of Abnormal and Social Psychology*, 55, 104-113.
- Amir, O., Biederman, I., & Hayworth, K. J. 2011. The neural basis for shape preferences. *Vision Research*, 51(20), 2198-2206.
- Bar, M. (n.d). *Visual Stimuli Resources*. Retrieved from <http://barlab.mgh.harvard.edu/resources.htm>
- Bar, M., & Neta, M. 2006. Humans Prefer Curved Visual Objects. *Psychological Sciences*, 103, 449-454.
- Bar, M., & Neta, M. 2007. Visual Elements of Subjective Preference Modulate Amygdala Activation. *Neuropsychologia*, 45, 2191-2200.
- Bar, M., Neta, M., & Linz, H. 2006. Very First Impressions. *Emotion*, 6, 269-278.
- Eberhard, J. P. 2007. *Architecture and the Brain: A New Knowledge Base from Neuroscience*. Atlanta, GA: Greenway Communications, LLC.
- Gage, Fred H. "Neuroscience and Architecture." AIA 2003 National Convention & Expo. San Diego, CA. May 2003. Theme Presentation. Retrieved from: <http://www.anfarch.org>
- Gage, F. 2012. *Do Changes in the Environment Affect the Brain?* [Video file]. Retrieved from <http://www.anfarch.org>
- Gordon K. 1909. *Esthetics*. New York: Henry Holt
- Hebb, D. O. 1949. *The Organization of Behavior*. New York: Wiley.
- Hesselgren, S. 1987. *On architecture: An Architectural Theory Based on Psychological Research*. Bromley, UK: Chartwell-Bratt.

- Jansen-Osmann, P. & Heil, M. 2007. The Process of Spatial Knowledge Acquisition in a Square and a Circular Virtual Environment. *Advances In Cognitive Psychology*. V 3 (No 3). Retrieved from: <http://www.ac-psych.org/>
- Jencks, C., & Heathcote, E. 2010. *The Architecture of Hope: Maggie's Cancer Caring Centres*. Frances Lincoln.
- Juster, F.T., Ono, H., Stafford, F.P. 2004. Changing Time of American Youth: 1981-2003. *Institute for Social Research*. Retrieved from http://ns.umich.edu/Releases/2004/Nov04/teen_time_report.pdf
- Klepeis, N. E., et al. 2001. The National Human Activity Pattern Survey (NHAPS): A resource for assessing exposure to environmental pollutants. *Journal of Exposure Analysis and Environmental Epidemiology* 11(3): 231-252.
- Kurokawa, K. (n.d.). Maggie's South West Wales. *Kisho Kurokawa*. Retrieved from <http://www.kisho.co.jp/page.php/467>
- Labarre, S. 2012. Oh Hell No: 12 Iconic Logos Redrawn Using Comic Sans. *Fast Company*. Retrieved from <http://www.fastcodesign.com/1665774/oh-hell-no-12-iconic-logos-redrawn-using-comic-sans>
- Leder, H., Tinio, P.P.L., Bar, M. 2011. Emotional Valence Modulates the Preference for Curved Objects. *Perception*, 40, 649-655. doi: 10.1068/p6845
- Madani Nejad, K. 2007. *Curvilinearity in Architecture: Emotional Effect of Curvilinear Forms in Interior Design* (Doctoral Dissertation). Retrieved from <http://repository.tamu.edu/handle/1969.1/5750>
- "Maggie's." (n.d.). *Maggie's Centres*. Retrieved from <https://www.maggiescentres.org/>
- MJP Architects. (n.d.). Maggie's Cancer Care Centre Cheltenham. *MJP Architects*. Retrieved from <http://www.mjparchitects.co.uk/projects/maggies-cancer-care-centre/>
- Nanda, U., et al. 2013. Lessons from Neuroscience: Form Follows Function, Emotions Follow Form. *Intelligent Buildings International*. 5(s1): 61-78.
- Nanda, U., Pati, D., & McCurry, K. 2009. Neuroesthetics and Healthcare Design. *Health Environments Research & Design Journal*. Retrieved from <http://www.herdjournal.com/article/neuroesthetics-and-healthcare-design>
- Ott, W.R. 1989. Human Activity Patterns: A review of the literature for estimating time spent indoors, outdoors, and in transit. *Proceedings of the Research Planning Conference on Human Activity Patterns*, EPA National Exposure Research Laboratory. EPA/600/4-89/004: Las Vegas, NV.
- Read, M.A., Sugawara, A.I., & Brandt, J.A. 1999. Impact of Space and Color in the Physical Environment on Preschool Children's Cooperative Behavior. *Environment and Behavior*, 31(3), 413-428.
- Renner, M.J., & Rosenzweig, M.R. 1987. *Enriched and Impoverished Environments: Effects on Brain and Behavior*. New York: Springer-Verlag. 12-38.
- Rosenzweig, M. R. 1979. *Development and Evolution of Brain Size*. *Academic Press*. 263-293.
- Rosenzweig, M.R., Bennett, E.L., Hebert, M. & Morimoto, H. 1978. Social Grouping Cannot Account for Cerebral Effects of Enriched Environments. *Brain Research*. 153, 563-576.
- Snohetta. (n.d.). Maggie's Cancer Caring Centre. *Snohetta*. Retrieved from <http://snohetta.com/project/23-maggies-cancer-caring-centre>
- Tsang, A. M., Klepeis, N. E. 1996. Descriptive Statistics Tables from a Detailed Analysis of the National Human Activity Pattern Survey (NHAPS) Data. *U.S. Environmental Protection Agency*. Washington, D.C.
- Tuma, R.S. 2006. Architecture, Neuroscience Intersect. *BrainWork*, November/December 2006. Retrieved from <http://dana.org/news/brainwork/archives.aspx>
- Ulrich, R. 1984. View Through A Window May Influence Recovery From Surgery. *Science*. New Series, V 224, Issue 4647. Retrieved from <http://www.jstor.org>
- Ulrich, R. 2013. Designing For Calm. *The New York Times*. Retrieved from: <http://www.nytimes.com/2013/01/13>
- Ulrich, R., Bogren, L. & Lundin, S. 2012. Toward A Design Theory For Reducing Aggression In Psychiatric Facilities. *Arch12:Architecture/Research/Care/Health*. Chalmers Gothenburg.
- van Praag, H., Dempermann, G., Gage, F. 2000. Neural Consequences of Environmental Enrichment. *Nature Reviews Neuroscience*, 191-198.
- Vartanian, O. et al. 2013. Impact of Contour on Aesthetic Judgments and Approach-Avoidance decisions in Architecture. *PNAS*, 110(2).

Sound design intervention in an open studio: Linking behavior, spatial, and acoustic analysis

Aaron Michelle Baker¹

¹Southern Polytechnic State University, Marietta, Georgia

ABSTRACT: Design studio spaces in Architecture schools are unique classroom settings because two different types of teaching occur simultaneously. Desk critiques and presentations are conducted side by side by multiple professors/students for multiple courses of varying subject matter and skill level in an open-plan setting. The empirical evidence demonstrates that noise pollution effects speech intelligibility, speech privacy, productivity, and satisfaction. This study aims to understand the impact of noise generated by the various instructions occurring concurrently on the learning effectiveness in Architecture schools and to offer design solutions to mitigate noise pollution.

This study combines spatial and acoustic analysis of the architecture design studio at Southern Polytechnic State University and behavioral studies of the inhabitants of the space. These findings can be used to inform design solutions in similar open-plan studio spaces in architecture and design schools.

INTRODUCTION

Architecture studio is the primary space in architecture schools in addition to standard educational spaces of classrooms, individual offices and administrative support. They support the design activities that are central to the curriculum of the architecture school, often including hands-on and collaborative exercises. Unlike the studio layouts used in other parts of the world, the studio space in architecture schools in the US often consists of an open-plan space including student workspaces divided with low partitions. The partitions create visual privacy for the student while they are seated, but once standing they have visual contact with the entire space. While an open-plan benefits visibility, access to daylighting, views of the outdoors, and an ease of communication for group collaboration, the partitions do not offer acoustic privacy. The structure of the courses held within the studio space is also varied, as the professors conduct lecture, desk critiques, informal group lessons, and pin-ups (project presentations). It is common for neighboring studio sections to perform different activities concurrently according to flexible work processes, i.e. while a studio section is involved in quiet individual work; the neighboring section is carrying out a design review that often involves loud conversations and exchanges; oftentimes causing noise distractions for student and faculty. This causes students to have difficulty understanding their professor as instructions or lessons are given and create a situation of lowered academic performance for students.

The requirements of an architecture studio are seemingly opposing, as students and professors need visibility and easy access to other students for group partnership and communication, while there is also a need for auditory privacy and clarity for students learning. A balance through design is needed to create an atmosphere that can nurture the interaction needs of the education process while also preserving the auditory needs for optimal learning.

To date, several studies that discuss collaboration and acoustic properties of education spaces have focused on traditional classroom settings in primary and secondary schools without addressing the unique setting and requirements of architecture studios. This paper aims to bridge this knowledge gap by means of analyzing behavioral, spatial and acoustic conditions in an architecture studio in the context of similar studies carried out in workplace settings. The argument is developed in four parts. First, the paper discusses the analogy between open-plan office settings and architecture studios due to the similarity of collaboration. Second, we discuss the effect of acoustic climate on learning by studying the research conducted in traditional classrooms. The knowledge about the effect of acoustic conditions gained from these studies can be applied to architecture studios since students share the same characteristics in learning. Third, the paper reviews the properties of sound and materials that can be incorporated inside studio settings for the purpose of mitigating the acoustic climate. This information is invaluable to understanding the needs of architecture studios and how to better design for them. Finally, the paper offers a few design solutions aimed at improving the spatial and acoustic properties of open-plan architecture studios.

1.1. Commonalities in layout, work processes and acoustics between architecture studio and den office

Parallels and analogies exist between architecture studio and office layouts as they both support varied and changing activities. Architecture studios have not been thoroughly investigated, unlike open-plan offices that have been extensively analyzed due to the need of corporations to enhance the productivity and satisfaction of their employees. Office settings have been the focus of continued investigation, speculation, and research. The following argument is developed on the knowledge generated in the office design field, given similar work processes of open-plan offices and architecture studios.

Based on Duffy's classification of office settings (Duffy, 1997), we propose to categorize architecture studio as a den given the low degree of autonomy and high interaction. According to Duffy (1997), den spaces are "arranged in an open-plan office or group room and are associated with group work". Though the noise distractions of an open studio are known to those who use them, not much research has been done on these spaces. Architecture studios are similar in construct to open-plan offices. Accepting the strong similarities, one can adopt the lessons learned in the design and research of open-plan offices to better understand architecture studios. Recognition of the correlation between studio spaces and open-plan offices allows one to utilize the vast research conducted on open-plan offices.

According to Duffy (1997), offices were created to house and process large amounts of information created by manufacturing and distribution. In the 1960's the work force began to specialize, this transformation informed the evolution of the office. With the elimination of corridors and partitions, it was believed that the open-plan layout would increase communication and allow more efficient supervision from management. (Bradley, 2003; Navai and Veitch, 2003). Open-plan offices are preferred by many companies because they are cost effective and promote communication. These offices have connected spaces with low or no partitions in addition to large corridors that encourage unscheduled encounters. This creates an environment where communication is easier, but results in noise pollution.

Since the birth of open-plan offices, scholars have sought to determine the desired benefits of enhanced communication of open-plan are a reality. Many studies have shown the benefits of connectivity in open-plan offices (Duffy, 1997; Hillier and Penn, 1991; Peponis and Wineman, 2002). Meanwhile, other studies have determined that the noise generation and lack of privacy are problematic (Bradley, 2003; Cangelosi and Lemoine, 1988; Evans, 2003). Studies conducted in the 1970's and 1980's observed background noise of open-plan offices of 79 dB(A). The drop in background noise in current studies can be attributed to modern machinery producing less noise; though improved, the ambient noise levels of open-plan offices remains unsatisfactory. Current surveys document noise levels ranging from 46-58 dB(A) which coincide with reports of lowered acoustic satisfaction from workers (Navai and Veitch, 2003). Employee feedback express frustrations of overhearing coworkers conduct business via telephone in adjacent cubicles. Discomfort with auditory stimulus has been shown to correlate directly with absenteeism, high turnover rate, illness, and an overall dissatisfaction in staff. In contrast, an environment that does not experience distraction from auditory stimulus is an important factor in increased productivity.

1.2. Acoustic levels and learning performance in educational facilities

While there are not studies that have specifically addressed architecture studios, we are discussing how an environment with higher levels of noise affects learning. The type of work conducted in traditional classrooms differs from architecture studios in that only one lecture is conducted at a time whereas in architecture studios many courses are conducted simultaneously with varying activities. Regardless of this difference, the importance of lecture and students understanding is the same.

Research has been conducted on the acoustics of classrooms (Crandell and Smaldino, 2000; Dockrell and Shield, 2006; Klatte et al., 2010; Mikulski and Radosz, 2011; Nelson and Soli, 2000) with the focus on primary and secondary schools. There has been limited research on how acoustic conditions influence learning in higher education settings. Though the information gathered is from primary and secondary schools, the data resulting from the studies can be applied to a broad range of student age levels.

Research suggests that classrooms with poor acoustics may generate "a negative learning environment for many students" (Dockrell and Shield, 2004). Prolonged contact with acoustic distractions in a classroom can negatively affect a student's academic performance and information processing (Dockrell and Shield, 2004; Persson et al., 2013). Teaching in a classroom is performed orally from a professor while in return the student learns aurally. This exchange is dependent on the acoustics of the room allowing for the student to hear the professor clearly. This is known as the signal to noise ratio (SNR). Interior room surfaces reflect, transmit, and absorb part of sound energy. If the surface is dense, smooth and reflectivemost of the sound energy will be reflected. If the surface is thin most of the sound energy will transmit through. If the surface

has a thin porous layer on top of a hard, dense layer, such as carpet on concrete, most of the sound energy will be absorbed.

Decreasing reverberation time will increase the SNR and speech intelligibility. Within an enclosed space sound energy will reflect off many times before it decreases by 60 dB or more. The time (in seconds) it takes for this to occur results in the reverberation time. An increase in sound absorption will decrease the reverberation time. ANSI/ASA S12.60 standard limits the maximum reverberation time to 0.6 seconds for core learning spaces less than 283 m³ though others suggest the reverberation time not surpass 0.5 s (Person et al, 2013; Treasure, 2007). A potential solution to decrease the reverberation time of the space would be to install materials that are more acoustically absorptive.

Installing absorptive materials to mitigate noise transmission throughout the space is particularly useful in situations such as architecture studios where the need to preserve visual connectivity and communication is imperative to its daily use. The reduction of noise in open-plan becomes difficult, due to sound energy passing over the partition, or diffracting around these partial walls. Acoustic ratings of materials assist in selecting materials that benefit the acoustic climate of a space. The NRC (noise reduction coefficient) is a measurement of the reduction coefficient and the absorption quality of a material, with a rating (evaluated from several frequency bands) ranging between 0 and 1. A rating of 0 indicates none of the sound energy is absorbed, whereas a rating of 1 indicates the material is 100% absorptive. Table 1 documents typical materials in architecture studios and their corresponding NRC rating.

Table 1: NRC ratings of typical materials used in education facilities and architecture studios.

Material	NRC Rating
Concrete block (unpainted)	.05-.35
Concrete smooth (unpainted)	.00-.20
Glass	.05-.10
Gypsum	.05
Wood	.05-.15

1.3. Case study: architecture studio at Southern Polytechnic State University

The architecture studio of Southern Polytechnic State University is located on the second floor of a building constructed in 2000, and is used by third and fourth year students. Each student is given a permanent workstation for the duration of the semester. Workstations have a drawer stack, work surface, and low partitions for pin-up space that also provides electrical outlets. The partitions are composed of metal studs and painted homasote (figure 2). Tasks conducted at workstations vary depending on requirements of the studio, including drafting, sketching, and model building. The structure of a studio changes on a daily basis as professors require desk critiques, pin-up presentations, and group instruction. The effect of alternating activities in adjacent courses often results in one section of students engaging in quiet drawing while the neighboring sections may be involved in loud group projects or instruction. The result of differing activities is a distraction to surrounding students. In addition to the typical noise generated from course activities, many students listen to music, streaming television, or movies as they work.

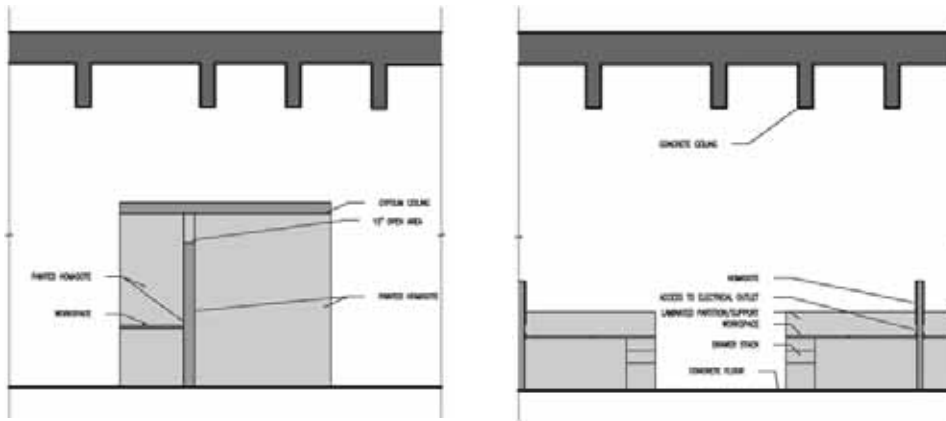

Figure 1: a) Section demonstrating the current conditions of pin-up area. b) Section demonstrating the current conditions of the workspace area.

The current design and configuration of the architecture studio does not mitigate sound generated by the courses it contains, but it does offer several benefits that need to be preserved. The low partitions provide visual access to the entire studio. In addition, they allow natural daylight to permeate the space. Open workspaces create an environment that accommodates group activities and unscheduled individual collaboration between students and professors.

In addition to workstations, the studio also incorporates five pin-up presentation spaces. These spaces have three eight foot high walls constructed of metal studs clad in seven foot high panels of painted homasote and a gypsum board ceiling. (figure2) Students present their work to their peers and professor in these spaces. The presentations are scheduled and unscheduled.

The floor and ceiling are concrete; the ceiling is coated in fire retardant spray foam (figure 2). The north and south exterior walls contain large glazing which allow natural light and outside views. The east and west walls are cinderblock interior walls.

1.4. Acoustic definitions

Sound pressure level (SPL) is a measurement (dB) intended to correlate the intensity of a sound and that effect on the human ear. The scale of decibels is logarithmic, therefore a doubling of sound energy is occurs every 3 dB. However, for the human ear to perceive the doubling of loudness, the sound would have to increase 10 dB (Navai & Veitch, 2003; Treasure, 2011), which is a ten-fold increase in sound energy. SPL ratings are weighted to account for the human ears detection of varying frequencies. The physical properties of a space can either enhance sound by offering ample space for vibration, or retard the sound based on the materials chosen. Sound waves are transmitted, reflected, or absorbed into a material. The utilization of sound absorbing materials drastically reduces sound reflected back into the room. Sound absorbers are composed of porous material with interconnected pores, an imperative property to dampening sound. In addition, the thicker the material is, the more effective it will be at absorbing sound. The absorption coefficient indicates the effectiveness of a sound-absorbing material (Egan 1988). These absorption coefficients vary with frequency. The weighted combination of sound absorption coefficients at several frequency ranges lead to the NRC rating discussed earlier.

1.5. Sound measurements and experiments within architecture studio

We analyzed the studio space at SPSU using a Larson Davis Model 831, a type 1 sound level meter, following ANSI/ASA S1.13 standard. Calibration of the instrument was performed at the start and end of each daily experiment. Two types of sound experiments were conducted. The first was *in situ* and measured the hourly equivalent A-weighted level (L_{Aeq}) at different locations within the Design Studio. This was done to get an overview of the sound levels throughout a typical day. The second type of experiments was a semi-controlled measurement of a white-noise and pink-noise source at different locations.

For the in situ experiment, sound levels were gathered over the course of two days to ensure most conditions were measured (desk critiques, presentations, and group working sessions). During this time, students' locations as well as students moving through the space were recorded. This information was gathered in order to determine where the most traffic noise is generated in the studio, which can create distraction to other students working. In addition, another session of measurements were gathered during the late evening hours as a control using machine generated white and pink noise to create base levels. Due to cost and availability, a calibrated, standard noise generator and speaker were not available. Instead a phone app was used to generate white or pink noise, and a single small speaker was used to produce the noise. So approximated acoustical white and pink noise signals were not generated. But this is sufficient to determine how noise can affect the students working in a different area. The date, location, and times that the levels were registered are shown in figure 3.

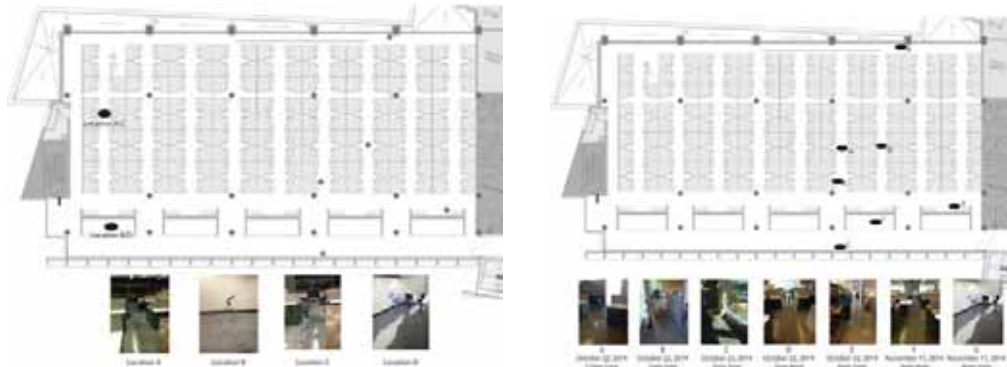

Figure 2: a) The location of audio speaker and sound level meter during the controlled experiment; b) In situ experiment's, indicated the location of sound measuring device during studio and associated date and time interval.

Students and professors were not given prior knowledge to the sound level meter being utilized in the space so no change in behavior would occur. The L_{Aeq} levels generated within the studio range between 49.4 dB and 59.6 dB, as shown in figure 4. L_{Aeq} is utilized to measure the sound generated in the space due to the nature of noise fluctuating over time due to spikes in sound levels. The L_{Aeq} is an A-weighted equivalent continuous sound level. Figure 4 presents the baseline L_{Aeq} readings of the controlled measurements. The use of white and pink noise generated a higher L_{Aeq} measurement than was registered with no acoustic stimulus. A spike in the L_{Aeq} is shown at the second location of the experiment where no acoustic stimulus was generated due to a group of students 15 feet from the sound measurement device engaging in a burst of laughter.

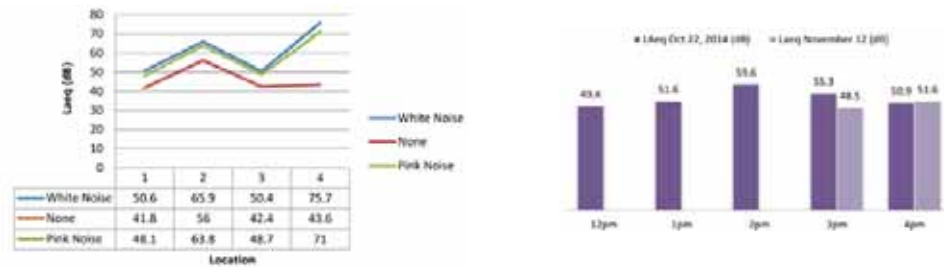

Figure 3: a) Line graph and chart showing the L_{Aeq} levels for each type of controlled noise generated. 1 is when the noise source was located B and the sound meter at A (ref Figure 1). 2 is when the noise source was located at B and sound meter at B. 3 is when the noise source is moved to C and the sound meter was at D, while 4 is when both noise source and meter were at C. b) Bar graph showing the L_{Aeq} levels for each hour of sound measurements taken. Note that the location changed for each hour measured, as shown in Figure 1b.

Students and professors participated in an anonymous questionnaire regarding their perceptions of the acoustic quality of the space. The questionnaire included of questions regarding the speech intelligibility of professors, level of noise distractions, and preferences of when to work in the studio. All students that have classes in the studio space were asked to participate in the study. The results showed that 81% of

participating students desk location were in the 2-3 desks near the pin-up space or the 2-3 desks in the center of their studio space, while 66.7% of participants indicated dissatisfaction with the noise level in studio. The main sources of noise referenced were individuals talking with neighbors, music played on a stereo or computer, and people traveling through the space. In addition, 52.4% of students responded they prefer to work in the studio in the morning or late at night, which correlates to responses that these are periods with the least amount of distractions. The Majority of participants (76.2%) responded they would be more productive if the acoustics were controlled more effectively.

1.6. Design intervention

In order to preserve the benefits of the open-plan architecture studio space, we recommend an efficient use of materials to mitigate the noise. To improve the absorption of the partitions of pin-up spaces, the painted homesote will be replaced with unpainted cork (figure 4). This will preserve the pin-up benefits of the wall material while improving the sound absorption for the overall space. In addition, acoustic clouds will be ceiling mounted. This will absorb the noise currently traveling toward the exposed ceiling and reflecting into the space. The floor is to be covered with carpet tile. The carpet will absorb sound within the space while allowing for easy repair, if necessary. These material adjustments will positively affect noise control in architecture studio because they are porous materials that absorb noise transmitted and reflected within the space. By absorbing more noise, the speech/noise ratio is improved as well as decreasing the distractions within the space.

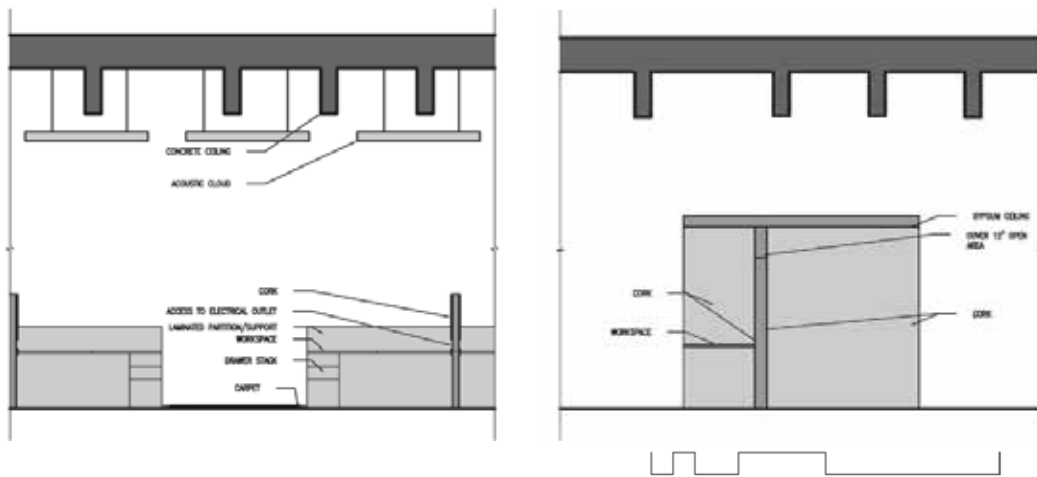

Figure 4: a) Section demonstrating the proposed conditions of pin-up area. b) Section demonstrating the proposed conditions of the workspace area.

CONCLUSION

Architecture studio is at the core of architecture education. For this area of the education to be integral and simultaneously under studied is an interesting problem. Open-plan studio encompasses various benefits, such as ease of communication, collaboration, and a high visibility. Though these benefits need to be retained, open-plan studio also has a large disadvantage; the acoustic properties of the space are less than desirable. The aim of this study was to determine the depths of consequences to working in an environment with poor acoustic properties. In order to achieve this, studies of open-plan offices and traditional education spaces were drawn upon.

Through the physical study of the architecture studio at Southern Polytechnic State University, sound measurements determined sound absorption was undesirable at best. Surveys conducted supported that

the noise levels of the studio created an environment of distraction for students. Many students indicated an increase in productivity if the noise were controlled within the space to decrease distractions.

Though further study is needed, the problem has been clearly identified. Creating a collaborative space that incorporates aural privacy is ideal for productivity and satisfaction in architecture studio. A design intervention based on adjusting construction materials is a solution that preserves the visual and collaborative benefits of the open-plan layout while mitigating the negative noise produced within the space. Experimentation with adjusting materials and material placement is the next step imperative to creating a substantial solution. The final results of this study will not only affect the architectural education community, but the design community of any open-plan space as the loss of productivity is documented in other open-plan spaces, such as offices; as the results will have the ability to be replicated in any space with similar parameters. Attention to sound in the design process is undervalued and long overdue.

ACKNOWLEDGEMENTS

The author thanks the Department of Architecture at SPSU for the support, the students who participated in the survey, and Ermal Shpuza and Richard Ruhala who provided valuable suggestions and insights that helped develop the research presented in the paper.

REFERENCES

- Alimohammadi, I., Sandrock, S., & Gohari, M. R. 2013. The effects of low frequency noise on mental performance and annoyance. *Environmental monitoring and assessment*, 185(8), 7043-7051.
- ANSI/ASA S12.60-2010/Part 1, Acoustical Performance Criteria, Design Requirements, and Guidelines for Schools, Part 1: Permanent Schools.
- Bradley, J. S. 2003. The acoustical design of conventional open plan offices. *Canadian Acoustics*, 31(2), 23-34.
- Cangelosi, V. E., & Lemoine, L. F. 1988. Effects of open versus closed physical environment on employee perception and attitude. *Social Behavior and Personality: an international journal*, 16(1), 71-77.
- Crandell, C. C., & Smaldino, J. J. 2000. Classroom acoustics for children with normal hearing and with hearing impairment. *Language, speech, and hearing services in schools*, 31(4), 362-370.
- Dockrell, J. E., & Shield, B. M. 2006. Acoustical barriers in classrooms: the impact of noise on performance in the classroom. *British Educational Research Journal*, 32(3), 509-525.
- Duffy, Francis, and Ken Powell. *The New Office*. London: Conrad Octopus, 1997.
- Egan, M. David. *Architectural Acoustics*. New York: McGraw-Hill, 1988.
- Everest, F. Alton, and Ken C. Pohlmann. *The Master Handbook of Acoustics*. New York: McGraw-Hill, 2001.
- Evans, G. W. 2003. The built environment and mental health. *Journal of Urban Health*, 80(4), 536-555.
- Hillier, Bill. "Chapter 7 Visible Colleges." *Space Is the Machine A Configurational Theory of Architecture*. New York: Cambridge UP, 1996. 190-214.
- Hongisto, V., & Haapakangas, A. 2008, June. Effect of sound masking on workers in an open office. In *Proceedings of Acoustics* (Vol. 8, pp. 537-542).
- Kaarlela-Tuomaala, A., R. Helenius, E. Keskinen, and V. Hongisto. "Effects of Acoustic Environment on Work in Private Office Rooms and Open-plan Offices - Longitudinal Study during Relocation." *Ergonomics* 52.11 (2009): 1423-444.
- Klatte, M., Hellbrück, J., Seidel, J., & Leistner, P. 2010. Effects of classroom acoustics on performance and well-being in elementary school children: A field study. *Environment and Behavior*, 42(5), 659-692.
- Mikulski, W., & Radosz, J. 2011. Acoustics of classrooms in primary schools-results of the reverberation time and the speech transmission index assessments in selected buildings. *Archives of Acoustics*, 36(4), 777-793.
- Navai, M., & Veitch, J. A. 2003. *Acoustic satisfaction in open-plan offices: review and recommendations*. Institute for Research in Construction.
- Nelson, P. B., & Soli, S. 2000. Acoustical Barriers to Learning Children at Risk in Every Classroom. *Language, Speech, and Hearing Services in Schools*, 31(4), 356-361.
- Persson, R., Kristiansen, J., Lund, S. P., Shibuya, H., & Nielsen, P. M. 2013. Classroom acoustics and hearing ability as determinants for perceived social climate and intentions to stay at work. *Noise and Health*, 15(67), 446.
- Rashid, M., Zimring, C., Wineman, J., Flaningam, T., Nubani, L., & Hammash, R. 2005, June. The effects of spatial behaviors and layout attributes on individuals' perception of psychosocial constructs in offices. In *Proceedings of the Fifth International Space Syntax Conference* (pp. 71-87).
- Rettinger, M. 1988. *Handbook of Architectural Acoustics and Noise Control: A Manual for Architects and Engineers*. TAB Professional and Reference Books.
- Schick, A., Klatte, M., & Meis, M. 2000. Noise stress in classrooms. In *Contributions to Psychological Acoustics—Results of the eight Oldenburg Symposium on Psychological Acoustics*. Bibliotheks-und Informationssystem der Universität Oldenburg.

- Spiliopoulou, G., & Penn, A. 1999. Organizations as multi-layered networks. In *Proceedings, 2nd Intl. Space Syntax Symposium* (pp. 1-24).
- Stringer, A., Dunne, J., & Boussabaine, H. 2012. Schools design quality: A user perspective. *Architectural Engineering and Design Management*, 8(4), 257-272.
- Treasure, J. 2011. *Sound business*. Management Books 2000 Limited.
- Wenmaekers, R. H., Hout, N. V., Luxemburg, R. V., & Hak, C. C. J. M. 2009, August. The effect of room acoustics on the measured speech privacy in two typical European open plan offices. In *proceedings Internoise* (pp. 23-26).
- Woodford, C., Prichard, C., & Jones, R. 1998. Listening conditions in higher education classrooms: One method of improving them. *Education*, 129.

BUILDING
TYPES AND
DESIGN
METHODS

A holistic approach to urban and architectural design with housing sustainability paramount

Sara Alinaghi Pour¹, Brian R. Sinclair²

¹University of Calgary, Calgary, Alberta, Canada

²University of Calgary + sinclairstudio inc., Calgary, Alberta, Canada

ABSTRACT: The field of sustainable development began to draw public attention in the mid-1970s – over ensuing years the pursuit of sustainable design has sought to benefit residents through positive influence on rate, type, location, and the cost of growth. Ideally, sustainable urban design should support the provision of high quality spaces and healthy places. Our roles as Architects and Environmental Designers remain, fundamentally, to improve the quality of life for people living and working in our projects. We strive to attain this goal despite growing obstacles, including depleting resources, increasing pollution, tightening budgets, escalating regulations and a milieu increasingly known for its isolation, indifference and even hostility.

Sustainable communities and greener projects are often correlated with overall higher costs of housing, whether through purchase or rental. This paper argues that truly sustainable developments must aim for greater diversity, heightened accessibility and more affordability. How might designers best approach the challenge of attaining greener, more integrated and inclusive communities? With regard to creating such communities, and realizing more sustainability in existing cities (often struggling with rampant urban sprawl), what possibilities are there to transform and modify the urban fabric in sensitive, sensible and sustainable ways? To answer these pressing research questions, this paper presents a new platform of knowledge for reconsidering/redesigning current projects, communities and cities in ways that are far more integrated, inclusive and balanced than have been seen before. Using both Sinclair's Framework and Gestalt Theory, the research suggests that our steps should be more considerate, open-minded and over-arching. Sustainability in urban design and architectural design, keeping housing affordability in mind, must not be narrow and restrictive, but rather should embrace a collection of qualities seen in interwoven and interrelated ways. Considering the intense pressures and spectrum of challenges confronting designers, finding new, potent and responsible paths forward proves paramount.

There is pressing need for more integrated, innovative, comprehensive and holistic ways of addressing urban & architectural design with greater housing sustainability in mind. While other scholars have approached sustainable design through a variety of discipline-specific methods, the significance of the present researchers' contributions is to underscore and incorporate a far more integrative strategy. This paper investigates and identifies key qualities of holistic urban design and architectural design with greater sustainability of housing front-of-mind.

KEYWORDS: *design, conceptual framework, integration, holism, housing sustainability*

INTRODUCTION

"Everything must be made as simple as possible. But not simpler." Albert Einstein

Our contemporary world is intensely challenged to travel a path towards greater sustainability. Our planet is now more urban than rural. Our cities are under pressure to steward resources while raising quality of life. Separation, isolation and fragmentation all too commonly define an ethos of emergency. To achieve the goal of sustainable and holistic urban design, in concert with housing sustainability, more partnership, collaboration and interdisciplinarity between various sectors is required. Sustainable development and New Urbanism are terms frequently used between creative classes for the provision of livable and green urban neighborhoods (Florida, 2002). In this regard, Gehl recommends the provision of new urban areas where places are complete, affordable, people-friendly, walkable, accessible, and connected (Gehl, 2010; Gehl, 2011).

Today, over half of the world's population lives in cities (Fraker, 2013). The incorporation of social, psychological and cultural dimensions of urban design, together with sustainable housing, needs to meet the diverse and complex needs of residents living in our communities. Friedman (2007) emphasizes that "the need for space adaptation to on-going life circumstances is important in New Urbanism and Architecture." Designers need to create environments which are far more fluid, flexible and responsive (Sinclair, 2014).

In the creation of sustainable urban design, including an array of associated housing types, many factors, including green design, suitable location, sufficient production, and effective policies and instruments must be

Sustainable urban design often comprises a more compact fabric and includes a rich mixture of commercial, residential and other uses. It realizes a broader range of housing sizes and types, cultivating diversity in cities. Such mixed-use developments, with an accompanying assortment of sustainable housing choices, transit oriented development (TOD), pedestrian-friendly areas, and reduced sprawl, prove to be important ingredients in a formula for more livable communities. Conversely, poor urban planning risks include a lack of spirituality in spaces, the isolation of older people from mainstream society, heightened traffic problems, and daunting environmental issues including degraded air quality and water pollution.

In conventional practice, sustainable and affordable housing has rarely been considered alongside sustainable urban design. In our cities, sustainability and affordability are negatively correlated with each other because “more sustainable” often means “less affordable” (Friedman, 2012). Neighborhood amenities such as proximity to TOD stations, pedestrian safety, access to complete streets and innovative housing structures have important roles in determining the affordability of living and sustainability of neighborhoods (Friedman, 2012). Residents who can spend a greater percentage of their income on housing are more likely to have more favorable attitudes about their life standards. To the contrary, residents who cannot invest more towards their housing circumstances tend to be less satisfied with their housing situation.

There are concerns about land development, quality of urban environments, cost and security of energy, environmental impacts of energy production, and associated environmental emissions (Anderson, Kanaroglou, & Miller, 1996). Present research underscores that designers and planners need to more aggressively develop strategies to address such concerns, including attention to climate change and reduced reliance on fossil fuels. While energy aspects are a key to greater sustainability, the authors suggest it is only one part of a far bigger picture that must be more holistic, integrative and interdisciplinary.

Designing sustainable environments is an intense holistic process that needs to balance social, cultural, environmental, economic, political and other aspects. The features of sustainable urban design are multi-dimensional and contextually-sensitive, including such aspects as: increased density, mix of uses and users, inclusion of accessible and affordable housing, transit-oriented development, livability, walkability, community gardens, energy strategies, adaptable design, etc. The nuances of location, including cultural qualities and geographic character, factor into the equation as architects endeavor to realize more sustainable buildings, developments, neighborhoods and cities.

While other scholars have approached sustainable design through a variety of discipline-specific methods, the present researchers underscore and incorporate a more holistic, integrative strategy. The present method builds from a more inclusive model that has been developed by one of the authors (Sinclair, 2008). The framework embraces the interdependency of social, cultural, natural and built dimensions of the environment. Sinclair’s Holistic Framework for Design + Planning requires any development to encompass four major interconnected elements of sustainable design & planning including agility, fitness, diversity and delight. Elements such as flexibility, adaptability and durability as well as mixed-use goals with surrounding livable and complete streets, walkable areas, convenient access to transit-oriented development, and green housing – together contribute to more sensitive and more sustainable outcomes.

1.0 RESEARCH QUESTION AND METHODOLOGY

Research explorations in Architecture and Urban Design, given their rich connections to dimensions both artistic and scientific, commonly stand as varied, inventive and stimulating. The primary research question that this paper probes is: With regard to creating sustainable communities, and realizing more sustainability in existing cities (often struggling with rampant urban sprawl), what possibilities exist to transform and modify the urban fabric in more sensitive, sensible and sustainable ways?

To answer this question, this paper critically reviews the issues surrounding sustainable architecture and urban design through new, more inclusive lenses. While existing models pertaining to sustainability, urban design, and housing have been well defined, weaknesses still exist surrounding their integration within a holistic system. The present researchers contend that the approach to a more successful urban design needs to be far more holistic, innovative, and sensitive to key issues. The solutions proposed by our research are less fragmented and more interconnected, providing a new vantage point in both the creation of new and retrofitting of existing communities.

This paper proffers an approach to creatively weave existing models into a new more integrated and holistic framework. The methodology specifically used to reach such ends includes meta-analysis of the literature, critical

assessment of prevailing theories, and logical argumentation and creative synthesis in the design, development and delineation of the new holistic framework.

2.0 STATUS QUO

Over the past few decades, various approaches have been proposed and/or practiced for achieving sustainable urban design. Each of these approaches tends to address different elements of this field – and each develops rather unique perspectives. However, the authors suggest that none of the approaches consider together the gamut of aspects truly needed for greater sustainability. In his book, *Good City Form*, Kevin Lynch mentions critical dimensions in planning such as: Vitality, Sense, Fit, Access, Control, Efficiency, and Justice. Regarding the importance of design with sufficient knowledge and wisdom, Canter (1977) writes, “Environments or places are defined by, and understood as, the physical characteristics of the place, the activities in them, and the meanings they hold for people.” While these points are vital, the push must reach farther and the integration must be deeper.

Our modern cities, on one hand, might include features such as Transit Oriented Development, Livable Streets, Complete Streets, and Energy Efficiency (LEED & LEED ND) which prove interesting concepts for design. However, on the other hand, they have frequently rendered costs of living higher and therefore become less affordable. Gehl (2011) notes that availability of housing that is located within sustainable communities, where places are complete, people-friendly, and accessible, walkable, and connected are important issues to be addressed. In reality, to date this goal has proven elusive because housing in such feature-rich developments warrant higher prices and demand higher rents. While the relationship between quality and cost is evident, it remains perplexing.

For instance, while there are clear benefits to Transit Oriented Development, there are significant challenges such neighborhoods must confront. Typical TODs usher in a number of concerns, as illustrated in the following list (Curtis et al., 2009):

- Dislike of change, concern about reduction of private gardens, green spaces, and increase in noise exposure commonly resulting from more compact development. Residents may feel that TOD developments do not belong in the area, exhibiting Not in My Backyard (NIMBYism), and an attitude that things are fine the way they are (Don & Tomalty, 2002).
- Fear of impact on their amenities and their lives (Bertolini et al., 2009).
- Fear of traffic and parking chaos (Renne, 2009).
- Concern about the development of natural environment, or in the case of “brownfield” sites, places that could be rehabilitated to have natural, recreational or open space value (Colquhoun & Hubbell, 2006).
- Fear that TOD will raise the housing costs of formerly affordable neighborhoods, pushing low and moderate-income residents farther away from jobs and transit. One criticism of TOD is that it has the potential to spur gentrification in low-income areas. “Gentrification” is a pattern of neighborhood change in which a previously low-income neighborhood experiences reinvestment and revitalization accompanied by increasing home value and or rents” (Greenwich & Wykowski, 2013).

Bertolini, Curtis and Renne (2009) argue that to best overcome the barriers of planning TOD areas, there needs to be rules to tackle and coordinate the entire process. Rules include “legislation, policy, practice, and responsibilities.” Relationships between organizations, institutions, organizations, and the wider community should be improved (Belzer et al., 2004; Dittmar & Ohland, 2003). Clearly there are many barriers erected that limit our current ability to generate more pluralistic, inter-connected, affordable and sustainable spaces, places, neighborhoods and cities. The present authors argue that more holistic strategies are in order if we are to advance the cause.

3.0 VALUE OF HEIGHTENED HOLISM

Given the multifaceted nature of sustainable urban design, we believe that adopting a more holistic approach would be an ideal and effective way of addressing this field. Sinclair’s Holistic Framework for Design + Planning was first introduced in 2009. This novel approach focuses on four action areas that are seen as having flexibility, interoperability and capacity for adaptation: Agility, Fitness, Diversity, and Delight. This all-encompassing framework has both robustness and resiliency, encouraging modification and customization depending on context, culture and circumstance.

In the design and planning of vibrant urban environments, it is essential to pursue, create and realize greater agility, better interrelationship of components, and more open systems (Sinclair, 2009). Important characteristics of agility include adaptability, durability, constructability, and materiality. With more agility in urban design comes elevated probabilities for improved health, increased satisfaction, more productivity, greater sustainability and enhanced interactions – in the end, better synergy between people and places (Sinclair, 2014).

Alexander's Theory of Wholeness teaches us to always bear in mind the overall structure and pattern of a place and to be mindful of a neighborhood's origins (Alexander, Ishikawa, & Silverstein, 1977). So, it seems essential to foster, invent and implement spaces, buildings and neighborhoods that are truly appropriate for the needs of people, the nuances of culture and the demands of context. The components of the category of fitness include the inter-related qualities of scale, detail, affordability, balance, natural/built, and resources (Sinclair, 2009).



Figure 1: Holistic integrated framework for design + planning (Sinclair, 2009)

Designers need to emphasize, envision and make spaces and places that contribute meaning, comfort and contentment into the lives of people (Sinclair, 2009). We must look at including and weaving together spirituality, health, wellness, beauty, attractiveness, safety, security, livability, and walkability (Sinclair, 2000). Delight is essential. Diversity is vital. Design is about connecting the dots, seeing the bigger picture, and realizing that the whole is indeed greater than the sum of the parts (Sinclair, 2005). Holism and Gestalt, in the minds of the authors, need to be passionately and successfully pursued in the urban design of more sustainable, affordable and livable communities.

4.0 SUSTAINABILITY + URBAN DESIGN

Sustainability is a pervasive term that has multiple meanings and diverse interpretations/applications. Sustainable urban planning, as highlighted by the authors, include such features as energy efficiency, higher-density development, mix of uses/users, provision of public & open spaces, walkable neighborhoods, access to transit, assurances of affordable housing, presence of community gardens, and attention to overall quality of life.

Advantages of a meaningful public realm, including community gardens, come in providing opportunities for cooperation and sharing among & between residents (Griffin, 2003). In a similar vein, cohousing developments with facilities such as shared kitchens and mixed-use developments with amenity centers, bring exciting opportunities from outside to inside, offering community building possibilities at the specific levels of architecture.

Urbanist Jane Jacobs argued that an essential feature of any healthy city is an elaborate and finely textured diversity of uses that provides one another with strong mutual support, both economically and socially (Jacobs, 1961). The increased density of townhouse communities, combined with the need to reduce automobile dependency, prompted planners to create more walkable communities where pedestrian and cycling paths are as common as streets and alleys (Farr, 2012). A survey by the Canadian Heart and Stroke Foundation (2005), found that people who live in higher-density areas are at a lower risk of heart disease due to their active lifestyle (Friedman, 2005). Benefits of more sustainable planning come via the combination of residential, commercial,

5.3. Transit oriented development (TOD)

Transit is playing a much more significant role in our lives as resources run thin and our cities expand (i.e., physically and demographically). Calthorpe defined the term TOD in the 1980s – he defined a Transit- Oriented Development (TOD) as a mixed-use community within an average 2,000-foot (ten minute) walking distance of a transit stop and core commercial area (Calthorpe, 1993). Calthorpe (1989) emphasized that an intense/dense mixture of residential, office, retail, open space and public realms, developed in well-designed and walkable environments, creates an urban milieu that proves convenient, satisfying and successful for dwellers, workers and visitors alike.

In sustainable urban areas, the advantages of TODs include: improving air quality (Curtis, Renne, & Bertolini, 2009a), promoting walkability, safety, relieving traffic congestion, revitalizing inner-city neighborhoods, and improving energy efficiency through supporting non-motorized forms of transportation. TOD stations increase the level of safety, comfort, affordability, and vibrancy in neighborhoods (Calthorpe & Fulton, 2001).

In a more sustainable community, there should be access to TOD coupled with sufficient sustainable, diverse and affordable housing (e.g., high-rise and low-rise, attached and detached, mixed-use or multi-functional buildings, etc.). When this range of housing types is available, communities grow in socio-economic richness, interest and vitality. To achieve such sustainable and holistic developments we need far more communication, and shared vision between the various players and organizations engaged in the enterprise of neighborhood design, district planning and city building.

5.4. Smart growth

Integration is fundamental to our success, yet difficult considering the specialization and fragmentation endemic to modern Western lifestyles. Sustainable communities must combine people, land, and buildings to improve the physical, economic, and social environment (Friedman, 2007). Smart growth benefits residents by development of plans and programs which are designed to influence the rate, type, location, and the costs of growth.

Prefabrication and mass customization afford possible paths forward. If there is a mass production in housing there will arguably be less energy consumption for construction with more energy/material saved (Pitt, 2007). Energy can also be reduced through far more efficient infrastructure (Pitt, 2007). Effective use of materials, conservation of water, and greater durability/longevity of building components tend to accompany the construction of small-footprint, higher-density housing solutions. Friedman (2012) mentions; “Energy consumption is not limited to within the walls of a home, but extends to the neighborhoods as well”. Blurring boundaries between inside and outside, and eroding borders between architecture and urban design seem both sensible and necessary in our quest for sustainability.

Social mixing is of course part of a sustainable housing policy – the authors suggest heightened accessibility for social housing means the full range of incomes found in the broader society are brought into conversation. This mix of users, conventionally segregated in modern American cities, ushers in the possibility of ‘messy vitality’. History demonstrates that large-scale projects in many cities, with their high concentrations of low-income tenants (e.g., Pruitt-Igoe in St. Louis, Missouri, USA), is simply untenable and unsustainable. Such social exclusion strategies, common in efforts to manage post-WW2 growth, started to decline in the 1960s -- leading to the eventual stigmatization and labeling of such projects as “ghettos” (Van Dyk, 1995).

6.0 MODELING MORE HOLISTIC SUSTAINABLE URBAN DESIGN (SYNTHESIS)

The present paper has delineated some fundamental considerations, and a number of prevailing theories/practices, for more sustainable urban and architectural design. While many contemporary approaches are moving us closer to a more responsible and sustainable world, the authors contend that far more integration, interdisciplinarity and holism are required to tip the system. To this end a model is proposed whereby communication is extended, more voices are heard, greater collaboration is enacted and risks are taken.

By reconsidering Sinclair’s Holistic Framework with a greater emphasis on urban/architectural design with housing sustainability front-of-mind, the following model charts some new and important directions. In particular the model precipitates vital and valuable conversation across different topic areas in a more integrated and mutually beneficial manner.

The authors acknowledge the value of prevailing strategies, including attention to responsible housing, livable streets, transit-oriented development and smart growth. In general all of these vehicles bring greater value to our communities and cities. That said, the present researchers believe there is inadequate ‘cross-talk’ and insufficient attention to larger systems. In thinking beyond conventional approaches, the researchers propose a re-examination of these prevailing factors, a reconsideration of Sinclair’s Holistic Framework, and the addition of

5.3. Transit oriented development (TOD)

Transit is playing a much more significant role in our lives as resources run thin and our cities expand (i.e., physically and demographically). Calthorpe defined the term TOD in the 1980s – he defined a Transit- Oriented Development (TOD) as a mixed-use community within an average 2,000-foot (ten minute) walking distance of a transit stop and core commercial area (Calthorpe, 1993). Calthorpe (1989) emphasized that an intense/dense mixture of residential, office, retail, open space and public realms, developed in well-designed and walkable environments, creates an urban milieu that proves convenient, satisfying and successful for dwellers, workers and visitors alike.

In sustainable urban areas, the advantages of TODs include: improving air quality (Curtis, Renne, & Bertolini, 2009a), promoting walkability, safety, relieving traffic congestion, revitalizing inner-city neighborhoods, and improving energy efficiency through supporting non-motorized forms of transportation. TOD stations increase the level of safety, comfort, affordability, and vibrancy in neighborhoods (Calthorpe & Fulton, 2001).

In a more sustainable community, there should be access to TOD coupled with sufficient sustainable, diverse and affordable housing (e.g., high-rise and low-rise, attached and detached, mixed-use or multi-functional buildings, etc.). When this range of housing types is available, communities grow in socio-economic richness, interest and vitality. To achieve such sustainable and holistic developments we need far more communication, and shared vision between the various players and organizations engaged in the enterprise of neighborhood design, district planning and city building.

5.4. Smart growth

Integration is fundamental to our success, yet difficult considering the specialization and fragmentation endemic to modern Western lifestyles. Sustainable communities must combine people, land, and buildings to improve the physical, economic, and social environment (Friedman, 2007). Smart growth benefits residents by development of plans and programs which are designed to influence the rate, type, location, and the costs of growth.

Prefabrication and mass customization afford possible paths forward. If there is a mass production in housing there will arguably be less energy consumption for construction with more energy/material saved (Pitt, 2007). Energy can also be reduced through far more efficient infrastructure (Pitt, 2007). Effective use of materials, conservation of water, and greater durability/longevity of building components tend to accompany the construction of small-footprint, higher-density housing solutions. Friedman (2012) mentions; “Energy consumption is not limited to within the walls of a home, but extends to the neighborhoods as well”. Blurring boundaries between inside and outside, and eroding borders between architecture and urban design seem both sensible and necessary in our quest for sustainability.

Social mixing is of course part of a sustainable housing policy – the authors suggest heightened accessibility for social housing means the full range of incomes found in the broader society are brought into conversation. This mix of users, conventionally segregated in modern American cities, ushers in the possibility of ‘messy vitality’. History demonstrates that large-scale projects in many cities, with their high concentrations of low-income tenants (e.g., Pruitt-Igoe in St. Louis, Missouri, USA), is simply untenable and unsustainable. Such social exclusion strategies, common in efforts to manage post-WW2 growth, started to decline in the 1960s -- leading to the eventual stigmatization and labeling of such projects as “ghettos” (Van Dyk, 1995).

6.0 MODELING MORE HOLISTIC SUSTAINABLE URBAN DESIGN (SYNTHESIS)

The present paper has delineated some fundamental considerations, and a number of prevailing theories/practices, for more sustainable urban and architectural design. While many contemporary approaches are moving us closer to a more responsible and sustainable world, the authors contend that far more integration, interdisciplinarity and holism are required to tip the system. To this end a model is proposed whereby communication is extended, more voices are heard, greater collaboration is enacted and risks are taken.

By reconsidering Sinclair’s Holistic Framework with a greater emphasis on urban/architectural design with housing sustainability front-of-mind, the following model charts some new and important directions. In particular the model precipitates vital and valuable conversation across different topic areas in a more integrated and mutually beneficial manner.

The authors acknowledge the value of prevailing strategies, including attention to responsible housing, livable streets, transit-oriented development and smart growth. In general all of these vehicles bring greater value to our communities and cities. That said, the present researchers believe there is inadequate ‘cross-talk’ and insufficient attention to larger systems. In thinking beyond conventional approaches, the researchers propose a re-examination of these prevailing factors, a reconsideration of Sinclair’s Holistic Framework, and the addition of

new dimensions/relationships concerning problem-seeking and problem-solving solving. We feel that a far more systemic interweaving of topics/issues can lead to far more meaningful strides forward.

While a more holistic project must consider important system factors such as social, environmental, and economics (Triple Bottom Line or TBL), we believe the efforts must reach farther. Designing sustainable neighbourhoods must embrace cultural, political, social, educational and other dimensions of living – in the end we need to ensure more inclusive healthy communities. This inclusivity, for example, can provide for more openness, celebrating diversity of people from different cultures, ages, and socioeconomic backgrounds.

The present model, synthesized based on perceived shortcomings of existing conceptual frames as well as limits of prevailing theories/practices, comprises four distinctive components that must work in concert (namely, Multiple Bottom Line, Site Synergies, Effective Transit & Principled Planning). Each of these components, in turn, evokes sub-components that should be explored, examined and included in the pursuit of more sustainable projects. Rather than relying on check-lists or formulaic methods of ‘greening’ projects, our model demands conversation, imagination and critical connections to transpire. Each project is unique in its complexities, circumstances, context and conditions. The new framework aspires to have projects assessed and discussed using a far more inter-connected series of lenses. The end goal is to ensure all aspects of the model have been tackled as a given project progresses – there is not a right or wrong outcome, but rather value in examining variables and values in more connected ways.

Multiple Bottom Line: The notion of transcending the conventional triple bottom line proves fundamental to this component of our model. Beyond environment, economy and equity, lie cultural richness, political maneuverings, spiritual charge, educational promise, etc. With respect to realize more sustainable urban design with housing quality paramount, we include the sub-components of ‘Sprawl Avoidance’ and ‘Innovation + Creativity’. While these features are sensible, the authors still consider their inclusion to be important to provoke thought and precipitate action.

Site Synergies: Too commonly buildings are seen in relative isolation to their context and the greater landscapes/ecologies in place. The researchers contend that building and site must speak together, and at the end of the day, should foster a Gestalt that captures place and cultivates community. Sub-components included to these ends are ‘Compact + Intense’ and ‘Brownfield Preference’. The drivers behind these items focus mainly on optimization of development, including right-sizing, remediation and regeneration.



Figure 2: A Holistic Approach to Urban & Architectural Design with Housing Sustainability Paramount

Effective Transit: The arrival of automobile-based planning, and subsequent neighborhood developments, has been highly problematic on numerous counts. Engineering exercise out of our lives has disastrous health implications. Dismantling proven approaches for street network design results in isolation and disconnection. The researchers argue that transit is core to contemporary livable and enjoyable communities and better quality of life. Sub-components include "Ease of Access" and "Pedestrian Priority", ensuring that humans are valued above mechanics.

Principled Planning: Finally, clinical zoning which has been so prevalent over the last century must be abandoned and remediated. In its place, we call for planning approaches fueled and informed by ethics and values that place people first. Many design schools' curriculums are devoid of courses addressing Environmental Psychology and Urban Sociology. Place-making and community-building is more than form, space, bricks and mortar. To the contrary, place and community celebrate people and their interactions are paramount to livability, satisfaction and happiness. Sub-components include 'Regulatory + Responsible' and 'Mixed uses + Users', which emphasize the proper place of people in our recipes for appropriate environments. Regulatory and Responsible are coupled to underscore the need for order and rules to be put in balance with user needs, wants, desires and dreams.

In applying this new conceptual framework there needs to be engaged debate, open conversation, both bottom-up and top-down initiatives, and, above all, a conscious commitment to systems thinking and holistic design.

CONCLUSION

"An ocean traveler has even more vividly the impression that the ocean is made of waves than that it is made of water." Arthur Stanley Eddington

Environmental designers must assertively take into consideration a daunting array of environmental, social, economic, cultural and spiritual elements, and do so in a far more integrated and holistic manner in order to attain and exceed minimum levels of sustainability. This recipe for progress necessitates a mix of both uses and users, natural and constructed landscapes, amenities and services, and new ways of working, dwelling and playing. Identification of spaces, delineation of needs, and characterization of place must be intertwined and inter-related as we reimagine our communities and recreate our cities. Hough (1990, 188) says; "Environmental literacy lies at the heart of understanding the places with which we are familiar, and thus are at the heart of the issue of identity". In sustainable community design and development, it is essential to consider, cultivate, and ensure a compatible array of land uses, a complementary collection of building types and synergistic community of stakeholders (Sinclair, 2009).

The consideration of the triple bottom line, involving physical, social, and economic dimensions, is a critical yet insufficient starting point (Sinclair, 2005). Architects and planners must pursue holism, innovation and integration with courage and ingenuity. Education is concurrently needed to equip and empower the public with the knowledge needed to embrace and espouse sustainable urban design with housing sustainability paramount.

In terms of responsible development with housing in mind, the authors argue that holistic and balanced strategies for planning and design can and must contribute to more affordable, accessible, healthy and successful communities. In summary, the formation of a holistic sustainable city can be described through the richness of Gestalt theory: It is the whole system that needs to be considered, the behavior of which is not determined by that of the individual parts, pieces and components but rather where the individual aspects/processes are themselves determined by the inherent character of the whole" (Guenay, 2007). In an ethos of declining resources, escalating urban growth, uncertainty in markets and heightened crises at unforeseen scales, there is an undeniable need to tackle and solve problems with new mindsets, emerging tools and an eye to the whole ahead of the parts.

REFERENCES

- Alexander, Christopher, Sara Ishikawa, and Murray Silverstein. 1977. *A pattern language: towns, buildings, construction*. Oxford: Oxford University Press.
- Alexander, Don, and Ray Tomalty. 2002. "Smart growth and sustainable development: Challenges, solutions and policy directions." *Local Environment* 7, no. 4: 397-409.
- Anderson, William P., Pavlos S. Kanaroglou, and Eric J. Miller. 1996. "Urban form, energy and the environment: a review of issues, evidence and policy." *Urban studies* 33, no. 1: 7-35.
- Architects, Gehl, and Urban Quality Consultants Copenhagen. 2004. *"Places for People."* Melbourne: City of Melbourne and Gehl Architects.
- Bagby, D. Gordon. 1980. "The effects of traffic flow on residential property values." *Journal of the American Planning Association* 46, no. 1: 88-94.

- Belzer, Dana, Gerald Autler, Judith Espinosa, Sharon Feigon, and Gloria Ohland. 2004. "The new transit town," in *The transit-oriented development drama and its actors.* (Washington, D.C: Island Press) 42-55.
- Bertolini, Luca, Carey Curtis, and John L. Renne. 2009. *Transit-oriented development: Making it Happen.* Surrey, England: Ashgate Publishing Ltd.
- Calthorpe, Peter, 1989. "The pedestrian pocket" in *Pedestrian Pocket Book.* (New York: Princeton Architectural Press), 350-356.
- Calthorpe, Peter. 1993. *The next American metropolis: Ecology, community, and the American dream.* New York: Princeton Architectural Press.
- Calthorpe, Peter, and William Fulton. 2001. *The Regional City.* Washington, D.C.: Island Press.
- Canter, David. 1977. *The psychology of place.* New York: Architectural Press.
- Dittmar, Hank, and Gloria Ohland, Eds. 2004. *New transit town: best practices in transit-oriented development.* Washington, D.C: Island Press.
- Duany, Andres, Elizabeth Plater-Zyberk, and Jeff Speck. 2001. *Suburban nation: The rise of sprawl and the decline of the American dream.* New York: North Point Press.
- Farr, Douglas. 2012. *Sustainable urbanism: urban design with nature.* New York: John Wiley & Sons.
- Florida, Richard. 2002. *The rise of the creative class: And how it's transforming work, leisure, community and everyday life.* New York: Basic Books.
- Fraker, Harrison. 2013. *Hidden Potential of Sustainable Neighborhoods: Lessons from Low-carbon Communities.* Washington, D.C.: Island Press.,
- Friedman, Avi. 2005. *Homes Within Reach: A Guide to the Planning, Design, and Construction of Affordable Homes and Communities.* New York: John Wiley & Sons Inc.
- Friedman, Avi. 2007. *Sustainable residential development: Planning and design for green neighborhoods.* New York: McGraw-Hill Professional.
- Friedman, Avi. 2012. *Town and terraced housing: for affordability and sustainability.* London: Routledge.
- Gehl, Jan. 2010. *Cities for people.* Washington, D.C.: Island Press.
- Gehl, Jan. 2011. *Life between buildings: using public space.* Washington, D.C.: Island Press.
- Greenwich, H., & Wykowski, M. 2012. *Transit oriented development that's healthy, green & just: Ensuring transit investment in Seattle's rainier valley builds communities where all families thrive.* Puget Sound Sage.
- Griffin, Lara, 2003. "Creating Affordable Housing in Toronto Using Public-Private Partnerships." Master's thesis, York University.
- Guenay, B. 2007. Gestalt theory and city planning education. *METU JFA* 1: 93-113.
- Hough, Michael. 1990. *Out of place: restoring identity to the regional landscape.* Yale University Press.
- Hubbell, John, and Dave Colquhoun. 2006. "Light rail transit in Calgary: The first 25 years." In Joint International Light Rail Conference.
- Jacobs, Allan B. 1995. *Great Streets.* Cambridge: MIT Press.
- Jacob, Ernest Fraser. 1993. *The fifteenth century, 1399-1485.* Oxford University Press.
- Jacobs, Jane. 2002. *The nature of economies.* Westminster: Random House.
- Jan, Gehl, Gemzøe Lars, Kirknæs Sia, and Sternhagen Søndergaard Britt. 2006. *New City Life.* Copenhagen: Danish Architectural Press.
- Lynch, Kevin. 1984. *Good city form.* Cambridge: MIT press.
- Pitt, Mary. 2007. Linking Social Housing and Energy Efficiency. Canadian Policy Research Networks
- Sinclair, Brian R. "Comprehension + Comprehensive: The Environmental Design of Spaces + Places". The Third Conference of the Ottawa Colloquium on the Governance of Sustainable Development. Ottawa, Canada, Center on Governance of the University of Ottawa, 2005.
- Sinclair, Brian R., Somayeh Mousazadeh, and Kamaran Noori. 2014. "Change: Exploring Psychological & Sociological Constructs in the Quest for Agile Architecture & Environmental Design." ARCC Conference Repository.
- Sinclair, Brian R., Somayeh Mousazadeh, & Ghazaleh Safarzadeh. 2012 "Agility, Adaptability+ Appropriateness: Conceiving, Crafting & Constructing Architecture of the 21st Century." Enquiry: ARCC Journal of Architectural Research 9, no.1.
- Thomsen, Kirsten Engelund, and Kim B. Wittchen. 2008. *European national strategies to move towards very low energy buildings.* Danish Building Research Institute.
- Van Dyk, Nick. 1995. "Financing social housing in Canada." *Housing Policy Debate* 6, no. 4: 815-848.

Building tall in the Arabian Gulf: Perception | performance | place-making

Fahad Alotaibi¹, Brian R. Sinclair²

¹University of Calgary, Calgary, Alberta, Canada and Qassim University, Saudi Arabia

²University of Calgary + sinclairstudio inc., Calgary, Alberta, Canada

ABSTRACT: Skyscrapers are arguably impressive, excessive, essential and ubiquitous in the intense landscapes of contemporary global cities. As a typology these towers are unparalleled in their costs, demands, parameters and presence. Perhaps more so than any region on the planet, the realities, including both remarkable challenges and outstanding opportunities, of building tall is illustrated and demonstrated in the emerging urban centres of the Arabian Gulf. Despite the massive impacts of this building type, and especially on the burgeoning cities in the Gulf States, research concerning place-making, social perceptions, and sustainable performance (i.e., systemic views) is undeniably lacking. The cities in this region have changed dramatically – transforming overnight from traditional human-scaled settlements, built by local materials and local expertise, into the modern oil-driven technology-propelled metropolitan hubs of today. Over the past two decades the Arab Gulf area has witnessed unprecedented urban growth, especially in vertical constructions which have flourished in Emirates cities such as Dubai and Abu Dhabi, and more recently in neighbouring Doha (Qatar), Kuwait City (Kuwait), and Riyadh & Jeddah (Saudi Arabia). In relatively spectacular bursts of development these cities have seen their skylines erupt, their streets defined and their buildings soar. Such transformation has multiple impacts on the city, including the shaping of a metropolitan image, influences on inhabitant perceptions and traction towards a more sustainable tomorrow. To gain a better understanding of the impacts of tall buildings in Arabian Gulf Cities, the researchers consider urban growth in three pivotal Gulf cities (Dubai, Kuwait City and Doha) from the early 1970s until present times. The present paper, a reporting of ongoing research in this stimulating field, encompasses two main parts: the first part outlines and explores master plans for each city, with aim to delineate policy and strategies for tall buildings, while the second part reviews work on several building case studies from each city, with a goal to critically examine aspects pertaining to perception, performance and place-making. The paper surveys at a general level the phenomenon of building tall, then moves beyond the general to tackle the specific, unique and compelling context, culture and circumstances of designing and delivering towers in the Arabian Gulf. A key outcome is an innovative framework for building tall in Gulf cities – a timely and necessary contribution that promises to help designers + developers and policymakers + politicians, to reconsider a more viable, responsible and successful path for these soaring, momentous, intensive and iconic skyscrapers. Considering the intense pressures for our buildings to reach higher, and the serious implications of housing greater numbers of occupants in our towers, there remains a pressing need to realize better understanding, more effective methods, and more sustainable outcomes.

KEYWORDS: Architecture, Tall Building, Framework, Performance, Place-Making

INTRODUCTION

“The skyscraper, by being much taller than the average construction, began to assume (whether or not it was wanted) a public role, that of primary contributor to the silhouette and image of the city of which it was a part.” Cesar Pelli

Architectural design is a complex and challenging yet remarkable activity. Architecture holds exceptional promise to impart satisfaction, wellness and meaning to users while concurrently contributing in significant ways to the identity, fabric and quality of cities. In our modern world the intricacies of realizing a building prove staggering, including complicated dimensions such as aesthetics, economics, legal concerns, cultural aspects and social factors. Increasingly our built environment is deemed to be too static and too intractable. There are, nonetheless and in response, pioneering efforts to challenge the status quo and introduce demonstrable change. Rigid approaches, fragmentation and separation are being replaced with more dynamic methods, integration and holism. Within this ethos bright directions such as open building, systems thinking and integrated design offer extraordinary mindsets + methods to create more appropriate, agile and potent architecture. Coupled into the equation are spectacularly shifting features of the design milieu including heightened pluralism, ecosystem assault, financial uncertainty and a rapidly globalizing planet. Within such a realm architects, engineers,

developers and others in the design & construction industry attempt to navigate turbulent waters, innovate process, advance product and improve the quality of spaces, places, buildings and cities.

Few building typologies are as demanding, daunting and complex as the contemporary highrise. Tall buildings operate at multiple levels of meaning and interpretation, from the site to the skyline. Exceptional technological aspects permit these forms to soar to unimaginable heights, supported by innovative structural and mechanical systems and inspired by scenography and iconic aspirations. Such projects dominate their communities, tax local resources, contribute to place, and hold the possibility to define identity. Skyscrapers from the historic Chicago Tribune Tower and the Empire State Building to the newly emerged Burj Al Arab and One World Trade Center play pivotal roles in providing personality to their cities. With the unbridled development in many cities around the globe, architects, developers and politicians are asking hard questions about such towers. Given the stature, presence and permanence of these mighty giants, it seems especially urgent for us to gain greater clarity, understanding and certainty around the implications, obstacles and opportunities of building tall. While performance stands front and center in such considerations, the definitions, parameters and metrics of performance in skyscrapers is shifting, developing, controversial yet critical.

1.0 CONCEPTUAL FRAMEWORKS

*"In Architecture as well as in all other Operative Arts, the end is to build well.
Well building hath three conditions: Commodity, Firmness and Delight."
On Marcus Vitruvius Pollio's de Architectura
Sir Henry Wotton The Elements of Architecture (1624)*

A conceptual framework is a vehicle for managing complexity, approaching problems, and directing processes towards desired outcomes. In an era where challenges arrive at unprecedented levels (e.g., scale, scope, frequency, etc.) there are increasing needs to be equipped with the means to move forward despite daunting complications, unfathomable dimensions, and a high degree of uncertainty. A part of the problem is due to endemic fragmentation that is common in contemporary societies, including nations and cities. The authors argue that more integrated and interdisciplinary approaches are needed when tackling environmental design challenges. This argument extends from the level of regional planning down to the design of individual buildings, including, for the purposes of the present paper, skyscrapers. A *Holistic Framework for Design and Planning* was first introduced by Sinclair in 2009. This novel approach focuses on four action areas that are seen as having flexibility, interoperability and capacity for adaptation: Agility, Fitness, Diversity, and Delight. Sinclair's framework has both robustness and resiliency, encouraging modification and customization depending on context, culture and circumstance.



Figure 1: Holistic Integrated Framework for Design + Planning (Sinclair 2009)

The present paper looks at the master planning of several key cities in the Gulf Region then pursues case studies of individual iconic high rises in these same centres. In many ways this work is analytical in character. Subsequently Sinclair's Holistic Framework is revisited in specific consideration of the skyscraper typology. Modifications to and extensions from this base framework are undertaken in an effort to customize and synthesize its value to the specific cultural, contextual and circumstantial conditions raised in the present paper. This work, in both its analytical and synthetic dimensions, is speculative and propositional. Given the absence of substantive research in this emerging field, the present efforts are geared to provoke vital questions rather than proffering concrete answers.

2.0 MASTER PLANNING

The emergence of the cities of the Gulf Region has been rapid, striking and largely without precedent. From fishing outposts and small villages to burgeoning cities and impressive metropolitan conurbations, the rise of the major urban centres of the Middle East have proven remarkable and at times spectacular. In many instances funded by resource wealth and keen to reach high, skyscrapers have sprung from the desert in forms and fantasies diverse and dramatic. As is true with most rapidly developing centres, master planning is invoked in an effort to capture vision, guide growth and help shape identity. Cities in the Gulf Region are no exception, with master planning commonplace and often iterative in nature. Under the pressures of such hurried progress such plans need frequent confirmation, adjustment and at times abandonment and redirection. The researchers have explored master planning in three primary cities in the area, in part to better understand the context of this part of the planet and in part to set the stage for case studies of individual skyscrapers from these cities/districts.

2.1. Dubai, United Arab Emirates

Dubai as a potent model influences many cities around the world, leading some scholars to coin the term 'Dubaiization' to express a new form of urbanization that relies extensively on capital markets. It also invokes processes of dividing a city into a collection of service hubs, sometimes referred to as cities (e.g., Education City, Medical City, etc.) inside a city. Moreover there is a pervasive myth that Dubai was raised up from a tabula rasa – from the vast emptiness of the desert. Yasser Elsheshtawy (2009) has endeavored to dispel this misconception in his book about Dubai's urbanization, delineating advancements from its humble beginning until the spectacular arrival of a world-class city. The present authors note that the city has hidden spaces which have largely been ignored by media and scholars alike – a region of Dubai representing the lower socio-economic strata or laboring class, which is dominated mainly by Asian migrant workers.

The history of inhabitation of the city began around 1833 AD when a subgroup from the Bni Yas clan (Almaktoum the current ruler of Dubai) traveled from Abu Dhabi to settle in an area between Abu Dhabi and Alsharjah. The population at that seminal time was approximately 800 (Ramos & Rowe 2013).

Dubai back then comprised a small land area, which was constituted with a collection of small mud huts, (Elsheshtawy 2009). In 1870 Dubai was declared by Britain as its principal port for the Empire's merchants in the Trucial States (i.e., the group of Sheikdoms they were under the British control from 1820 until 1971)(Ramos & Rowe 2013). The newly emerged emirate had two main resources, namely fishing and pearl hunting. Together these two economic factors played a crucial role in the growth of the area, continuing until the middle of the 20th century when the Japanese invented the cultured pearl.

General speaking, Dubai in the first half of the 20th century enjoyed the same architectural character of the Arabian peninsula cities -- mainly comprising narrow alleyways, mud buildings with courtyards, and the emblematic wind catchers (*Barjeel*). The city moved to a new phase of modern development when Sheikh Rashid bin Saeed Al Maktoum commissioned British architect John R. Harris to conceive the first master plan, which outlined main roads, zoned the city and shaped its infrastructure. In 1971, following the discovery of oil in 1966, Harris executed a second phase of the master plan, extending his vision for the new Dubai by establishing a ring road system, two bridges across Dubai Creek and connecting the outer housing area with the inner city (Ramos & Rowe 2013; Elsheshtawy 2004). The criticism of these two plans is they failed to tackle the rapid and admittedly unparalleled growth of Dubai. It is worth emphasizing that the creator of the Dubai plan was also the architect behind the first tall building in the region, the Dubai World Trade Centre. Sheikh Rashid had again hired Harris to design this important building, which was the tallest building in Arab world from 1979 until 1999 when the Burj Al Arab was completed (Elsheshtawy 2004).

2.1. Doha, Qatar

The history of Doha goes back to the first half of 19th century, and particularly in 1846 when the Al Maddhid tribe moved from the central Arabian peninsula (i.e., Najad), to settle in what was then known as Al Bidda on the Qatar peninsula. Economic resources during this period was again limited to fishing and pearl hunting. Demographics of the city comprised of the Al Maddhid tribe, traders, Persians, Bedouin people on the periphery of the city, and African workers (Salama 2013).

The population during the opening decade of the 20th century grew to 12,000 inhabitants (Adham 2008). Modern urbanization happened after the first exporting of oil, which was discovered in 1973. While the arrival of oil impacted all of the Gulf cities, there were especially dramatic impacts on the urban morphology of the Doha. The city shifted from a modest pre-oil settlement to a futuristic post-oil metropolis, emphasizing discrete services hubs as a model of the city of the 21st century. The situation in the early phase of the city was similar to other Gulf cities: using local materials for building and arguably more primitive methods of construction. Salama states that “homes based on the inherited dwelling construction knowledge of the indigenous population used local building materials such as palm fronds and trunks as well as coral, stones and mud” (Salama 2013). According to Khaled Adham the urban transformation of the city, between 1949 and 1990 might be categorized into four unique phases: firstly urbanity of transition (1949-1955), secondly urbanity of necessity (1956-1971), thirdly urbanity of modernization (1972-1984), and the fourth urbanity of stagnation (mid-1980s to early 1990s). The period before the beginning of the formal foreign planning process, which expanded from the 1950s until the mid 1960s, seemed haphazard and uncontrolled (Salama 2013). In 1974 the British firm Llewelyn Davis was hired to craft the first master plan for the city, which determined the guidelines for the city urban growth until 1990, based largely on the concept of the ring road and the division of the area into 69 administrative areas. Furthermore the plan aimed to revitalize the city center by removing older buildings in order to create a space for a modern commercial & governmental building. In 1977 the American consultancy William L. Pereira was contracted to produce a new master plan for a designated area (NDOD) North District of Doha (Salama 2013).

2.3. Kuwait City, Kuwait

The beginning of Kuwait as an urban settlement goes back to the 17th century when the Amir of Bni Khaled tribe built a *kote*, a small castle to spend his springtime beside the sea (Saleh 1994). This modest castle changed over time to become a small village surrounded by a defense wall, which was built to protect the local people from various attacks. This fortification was rebuilt three times over three centuries: the first one was built in 1760, followed by another wall in 1811, and finally the last wall was built in 1921 (Yasser 2008). Notwithstanding the deep history of Kuwait, such as the story of Failaka Island which was the home of an ancient civilization in 2000 B.C, the proposition of an emerging global city created by oil wealth, without precedent, still prevailed (Gardiner & Cook 1983).

The discovery of oil in the 1930s encouraged the ruler, Sheikh Abdullah Al-Salem Al- Sabah, to commence with modernization of the city -- by 1951 the first master plan for Kuwait City was depicted by the British firms of Minoprio + Spencely and P. W. Macfarlane. The master plan was based on the concept of a car-oriented environment, which comprised five main roads radiating from the city center (intersecting with ring roads that divided the new development area) to reach smaller neighborhoods that were self sufficient with facilities and amenities (Reem 2009). The dramatic consequences of this bold master plan's implementation proved unacceptable to environmental design professionals and the public alike. Mahgoub (2008) states that “this rapid urbanization created a built environment that was criticized by specialists and the public as being unfriendly, hostile and lacking a sense of belonging”. This criticism precipitated by the failure of the first master plan then led to a new master plan being conceived (1967-68) by Colin Buchanan & Partners. Their process began from a critical evaluation of the first master plan, ushering in improvements to the road system and the creation of new areas to attract people from the inner city while concurrently tackling congestion problems (Yasser 2008). The third phase of the master plan, crafted in 1990, arose through the collaboration of the firm SSH from Kuwait and W.S Atkins from the United Kingdom. This team was commissioned by the Kuwait Municipality to produce a new development plan for the city – one that anticipated and guided the city through rapid urbanization over the past three decades.

3.0 TALL BUILDING TYPOLOGY

In the late 19th century and beginning of the 20th century, a first generation of tall buildings arose in North American cities, most notably New York and Chicago. In fact Chicago's nine-story 1884 Home Insurance Building is considered as the first tall building driven by modern technology. While there were numerous dimensions of building technology which shaped the inaugural generation of tall buildings, three factors in particular paved the way towards skyscrapers as an emergent typology. The first breakthrough was the

invention of the elevator which allowed occupants rapid movement within higher reaching structures. The second feature was the development of the skeletal iron frame, an innovation that liberated the building skin from structural responsibility, making the walls lighter and construction faster. The third development was the invention of the curtain wall. (Abel 2003). A common characteristic for the first generation towers was the adoption of a tripartite vertical segmentation – much like the inspirational Classical Greek column. The early skyscrapers divided the façade into three formal parts: the base, the shaft and the top. This division was seen in pioneering towers such as New York’s Flat Iron building of 1902, and most of the tall buildings in Chicago of this same era. (Abel 2003).

Tall buildings in the first half of the 20th century subscribed to a similar spatial arrangement: typical floor plates repeating as the building reached skyward – consequently leading to a predictable and conventional form (Abel 2003). A next breed of tall building emerged mid-century, focusing on the structure’s role in shaping building height and form. Such advancements are seen in the pioneering work of engineer Fazlur Khan, an innovator who played a crucial role in realizing unprecedented structural systems, such as the tube approach in tall buildings. Brave structural strategies afforded opportunities for buildings to reach adventurous heights – for example, Khan implemented his leading ideas on two iconic towers in Chicago, namely the Sears Tower of 1974, and the John Hancock Building of 1969 (Abel 2003). Antony Wood (2008), in considering the typology’s place in a resource-challenged world, argued that the tall building is a sound option to achieve sustainability in the built environment. There are demonstrable advantages of building tall, including their roles in achieving higher density cities, reducing transportation costs, countering urban sprawl, and managing infrastructural implications as well as a high potential for renewable energy (e.g., wind and solar)(Wood 2008). Conversely and often controversially, tall buildings are recognized by many as serious contributors to greenhouse gases and CO2 emissions. The waste generated from this emerging type of building is larger than that of low-rise buildings. Additionally, tall buildings need an impressive amount of resources for construction, operation and maintenance (Roaf + Crichton 2005). Clearly there are both advantages and disadvantages to building tall in our contemporary times. The present authors accept this dichotomy to be a major challenge, and in response are researching ways in which advancements can be made on technological, sociological, psychological, cultural, political and other realms. There is no doubt that the typology is complex as are the associated opportunities and obstacles surrounding their creation and operation.



Figures 2 - 3 - 4: Burj Khalifa | Sinclair & Students Skyscraper Studio Field Trip | Mehrdad Amjadi Studio Project

4.0 CASE STUDIES

Given the significance of skyscrapers to the development of modern global cities, the researchers deemed case studies to be a valuable mechanism to better grasp the variables at play and the possibilities at hand. In looking critically at Sinclair’s Holistic Framework for Design + Planning, in light of the tall building typology, it is vital to explore in some depth the qualities and characteristics of skyscrapers that define them in the context of modern environmental design. Specifically, the authors identified three high-profile and praise-worthy towers in the Gulf Region, one in each of the three cities examined in the Master Planning section of the present paper. A key goal of the present research was to revisit and refine the conceptual framework given dimensions identified within

said case studies. With respect to the following skyscraper case studies, the authors deployed a structure for description/investigation which is typical for analysis of Architectural projects.

4.1. Burj Khalifa – Dubai, United Arab Emirates

Overview: The soaring Burj Khalifa is the tallest building in the world, an icon that places Dubai well ahead of the competition in the heated race for the sky. The tower, designed by SOM's Adrian Smith, has a height of 828m and is comprised of 163 floors. The construction of this award-winning tower started in 2004 and was completed in 2010.

Concept and Form: The goal of this project was not to merely build the tallest building, but rather to push the limits of human achievement (Weismantle, Smith & Sheriff 2007). The tower's form is Y-shaped, inspired by both a traditional desert flower and an Islamic pattern -- the architectural form relates to the architectural context of the place in such formal natural + cultural aspects. Although the three wings that shape the tower work efficiently, in a way that provides inhabitants with unobstructed views, from a structural point of view the reduction of these wings towards the top helps the tower resist the severe lateral forces from the wind. This is a good example where performance can be demonstrated in multiple domains, including cultural, sculptural and technical.

Environmental Concerns: Avoiding more explicit sustainable techniques in the tower such as wind turbines and photovoltaic cells, which have been a conventional approach in many towers around the world, the firm instead elected to pursue a sustainable approach to design which connects building and context. For example, one of the strongest features of the building is the open terraces at top levels of the tower. This strategy, deemed unacceptable in super tall buildings before then, proved successful in the Burj Khalifa. Typically the higher zones of tall buildings encounter high speed winds, resulting in uncomfortable conditions for occupants. However, in the Burj Khalifa the bold design, coupled with an integrated team of specialized engineers engaged in early wind modelling, led to wind effect mitigation, comfortable occupancy and breathtaking views. In arid dry climates such as Dubai, water is a rare resource and irrigation of landscapes is challenging. To address such realities the firm devised innovative approaches to condense hot humid air outside the building in order to provide moist air inside the building, a design gesture that resulted in a significant amount of water captured for irrigation of tower landscapes (approximately 15 million gallons per year)(Smith 2008).

Site & Context: The context of the Burj Khalifa is distinctive and unique, with the tower placed as the centerpiece of the new development area which is called the Dubai downtown (the traditional center was Dubai Creek). This new urban area consists of mixed-use residential, retail, and office development. The landscape for the area is well designed and well connected to public transportation (both train & bus networks). Additionally, the scale of the building relative to the context was an urban challenge for the designers—the solution sees a stepping back gradually towards the sky. In effecting these reductions as the tower rises, an elegant solution for the undeniable scale of this mega tower was achieved.

4.2. Doha Tower - Doha, Qatar

Overview: Doha Tower, the newest tall building in the country of Qatar and the sixth tallest tower in Doha, reaches to a height of 238m. It comprises 46 stories used primarily for offices with some for residential and hospitality aspects. This bold tower, designed by the well-known French architect Jean Nouvel, has a total area of 110,000 sq m. It creates an elegant landmark for the city of Doha with its impressive presence and innovative design. Moreover the building won the Council for Tall Buildings and Urban Habitat (CTBUH) award as the best building in the Middle East and Africa in 2012.

Concept and Form: The form of the tower is simple, with its design driven towards optimal spatial efficiency. The cylindrical geometry makes effective use of floor-to-window area and situates elevators in relative proximity for all offices (Wood 2012). Though the form is straightforward in its massing and disposition, the concept is focused more on the skin of the tower. Nouvel is a designer who has proven his abilities to reinterpret cultural and traditional symbols in architecture, making buildings that fit within historic settings in modern ways. The inspiration in the Doha Tower is the mashrabiya, which is a traditional pattern of timber lattice utilized in the region.

Environmental Concerns: The main sustainable feature in this building is the thoughtful consideration of the design of the envelope, the skin of the building, in a manner directly inspired by the Islamic mashrabiya. This technique protects the internal spaces of the project from heat gain while at the same time providing maximum levels of privacy – a quality which is important within traditional Islamic society and architecture. In this way Nouvel creatively designed the façade to not only perform technically but to reflect the deep roots of the local culture. From an energy savings perspective this innovative skin treatment reduced cooling load by 20%. The main theme for the façade tectonic deploys a single geometric motive, that is then repeated in different scales.

Through this mechanism diverse opacity levels are realized -- 40% on the south and 60% on the east and west (Al-Kodmany 2014).

Site & Context: The site for the Doha Tower is a suitable area for a high-rise building in the city, namely the new business district in West Bay. This urban district was planned to accommodate mixed-use development and to shape the city skyline. With future public transportation and the appropriate infrastructure in progress, the area contains a culmination of high rise buildings across Doha's waterfront. Furthermore this strategy of locating towers in a specific zone, with its applicable transportation system and sound infrastructure (i.e., designated for tall building) is arguably more sensible and sustainable (Goncalves 2010).

4.3. Al Hamra Firdous Tower – Kuwait City, Kuwait

Overview: Al Hamra Tower rises 412m in a temperate manner, providing the urban fabric of Kuwait City with an iconic building which sets the pinnacle of the skyline in elegant balance between the environment and the culture. Designed by Skidmore, Owings & Merrill (SOM) in 2005 and completed in 2011, Time Magazine recognized the building as one of the top innovations in design (Al Hamra 2014). The tower was conceived in a unique way that helps to achieve the designer's goal of thinking globally and working locally -- the project connects in a sensitive way with context, including the crafting of a form that reduces harmful solar gain, while concurrently maximizing views of the breathtaking Arabian Gulf.

Concept and Form: The tower's form comprises a spiraling hyperbolic paraboloid -- generated in consideration of two goals: firstly creating a delicate space that gives the occupants the maximum unimpeded views to the Gulf, while secondly, reducing solar gain to the lowest levels possible. The southern façade is protected by a semi-solid stone façade, with small openings that relate to the traditional local architecture. The other facades of the building are wrapped by transparent glass walls. This strategy of designing different sides of the tower in a manner highly responsive to unique climatic conditions led to the distinctive and poetic sculpted form.

Environmental Concerns: The delicate handling of the tower's surfaces resulted in an environmentally responsible tower -- the cut of the south quarter of the plan creates a void that efficiently protects the building from undue heat gain while simultaneously disrupting wind forces which then helps to stabilize the building in consideration of lateral forces (Asci & Sarkisian 2011). From a materiality perspective the tower's primary construction of concrete served as an ideal option given the hot arid weather, with this heavy material operating as a thermal mass that absorbs the heat in the day and releases it at night (Wood 2012).

Site & Context: Located in a distinctive setting within Kuwait City's central zone, the tower works as a remarkable landmark. The Al Hamra Tower connects to the ground in a poetic way, incorporating a 20m high lobby. The innovative use of a concrete lamella structure helps to transfer the structural loads to the ground without blocking space -- the space works as a profound integrative space between the strength of the tower and the urban texture of the neighbourhood (Parker & Wood 2013).

5.0 RECONSIDERING SINCLAIR'S HOLISTIC FRAMEWORK

In considering both the master planning of the three Gulf Region cities, and the subsequent case studies of single commanding Architectural projects therein, there are lessons to be grasped. No doubt city planning, when most effective, proves respectful to history and tradition while being sensitive to culture and context. Anticipating change, growth and development is also a vital quality of successful master planning. In many ways successful Architecture, especially at the scale of skyscrapers, also genuinely respects history and tradition, sensitively responds to culture and context, and anticipates tomorrow. Sinclair's Holistic Framework for Design + Planning aims to connect disparate elements in order to more effectively realize culturally-sensitive, better-integrated and more sustainable projects and precincts. The tall building is an especially unique Architectural typology. By virtue of its size, cost and complexity such projects warrant an extraordinary level of care and attention. In reconsidering Sinclair's Framework with tall buildings in mind, several key criticisms and recommendations are advanced by the present researchers:

Agility: The tall building must be able to handle future changes in quick and nimble ways, such as the need for more kinetic systems in façades, building skins that respond to the daily changes in weather, or aspects regarding flexibility in vertical circulation. Tall buildings are costly to construct, significant in volume and high in occupancy -- they last a long time which underscores the critical need for agility, mutability and adaptability over

time. Design and operations of tall buildings, due to their presence and permanence, must push the boundaries for agility in ways that exceed other typologies.

Fitness: The manner in which tall buildings relate to the landscape, including how they connect to the ground plane, is a major aspect of design of this typology. The harmony/symbiosis between the tall building and its surroundings is paramount. Designers must pay significant attention to the integration of the tall building with the urban realm, in particular as the scale and scope are commonly without precedent. To this end the researchers contend that these super tall structures need to reach out more assertively and effectively to the public in creative ways. Design must celebrate the tall building not merely as private space for corporations but also as public space for community. Increasingly, tall buildings will be called upon to engage more meaningfully in the life of cities.

Diversity: Tall buildings over much of its existence have been overwhelmingly focused on the provision of office space. However, as with the public's disdain for clinical zoning in city planning, Architectural designers scramble to introduce more messy vitality through a richer mix of uses and users in skyscrapers. Today tall buildings often encompass an array of uses. The present authors suggest that diversity needs to be a key goal of building tall. Dynamic combinations of office, commercial-retail, residential, cultural and recreational spaces, for example, should be included in tall building programs. Unexpected and interesting adjacencies and overlaps should be actively pursued in order to realize greater self-sufficiency, greater inter-dependencies and greater spatial/social interest.

Delight: Sinclair (2009) stressed the central role of delight in architectural equations for sustainability. While this elusive quality is often neglected in green building assessment and sustainability rating systems, it is undeniably a crucial quality of good/great Architecture. In the case of the skyscraper the need to pursue delight is amplified in profound ways. The profile, presence, permanence and power of these towers demands extraordinary efforts by design teams to get the 'delight' right. Design vehicles such as skycourts and vertical gardens, for example, hold promise to enhance the experience of space. Attention to green space and indoor environmental quality can contribute to the well being of occupants. Inclusion of aspects of mystery, surprise and the sensual, inside & outside, can provide pleasant encounters for users, visitors, neighbors and passers-by. Serious study of delight in the design of skyscrapers is lacking, in part due to its qualitative dimensions. That said, it remains a central variable and goal to be pursued with even greater vigor and resolve.

CONCLUSION

"What about guns with sensors in the handles that could detect if you were angry, and if you were, they wouldn't fire, even if you were a police officer? What about skyscrapers made with moving parts, so they could rearrange themselves when they had to, and even open holes in their middles for planes to fly through?" Jonathan Safran Foer

It is clear that the tall building, or skyscraper, has emerged as a dominant Architectural typology of the new millennium. Around the planet in major global cities buildings are reaching higher, in part a testament to advancing technological capabilities and in part a symbol of power, might and majesty. Yet, while the typology is developing and their numbers burgeoning, the authors believe that research in many areas pertaining to tall buildings is seriously lacking. A primary focus, concerning research and development, has been in the technical areas including structures, mechanical systems and building envelopes. While all of these dimensions of skyscrapers are crucial they alone may prove insufficient. Other aspects of tall buildings, including sociological, psychological, urban and landscape explorations, warrant urgent and intense attention. The present paper has critically considered the typology, with an emphasis on the emerging cities and centers of the Arabian Gulf Region. Rapid unprecedented urbanization is a hallmark of this region, including a dramatic presence of skyscrapers. Through the study of master planning efforts in Dubai, Doha and Kuwait City the authors have painted a picture of dramatic upheaval and change. Through the exploration of case studies of three towers in these cities an effort has been made to grasp the magnitude and impacts of building tall. Early in the paper an emphasis was placed on the value of conceptual frameworks to the cause of design and planning. Highlighting Sinclair's Holistic Framework the authors emphasized the value of far greater integration and interdisciplinary thinking when engaging in the complex enterprise of modern design and planning. Considering this framework in light of master plans and skyscrapers in Gulf cities, the researchers delineated key points to address when conceiving and constructing tall buildings – with an elaboration of Agility, Fitness, Diversity and Delight. Growth of tall buildings, in terms of height, volume and numbers, is anticipated to escalate not only in the Gulf Region but

elsewhere internationally, including of course the Asian Pacific arena. The present paper underscores the pressing need to attend to a far more holistic array of variables as skyscrapers are designed and developed. Beyond the obvious economic and political elements of tall buildings, the authors recommend great focus be directed to perception, performance and place-making. Skyscrapers contribute demonstrably and concurrently to the skyline, the district and the street. It is essential for designers and planners to consider the interplay and implications of such scales as tall buildings arrive to our cities. Performance can be measured along numerous lines and across many dimensions of tall buildings. Architects must move beyond the empirical easily-measured spheres and into the more interesting and arguably important ethos of meaning, beauty and value. Finally, place is space overlaid with significance. Space is geometric while place is emotive. Given the extraordinary power and presence of skyscrapers upon our land and within our cities, it is unquestionably imperative to elevate place-making to an art. Returning to the question of the Gulf Region, and given the unbridled pace of development, investing in research to answer these questions will pay huge dividends downstream. Ignoring the spectrum of forces at play, to the contrary, could translate into an assemblage of buildings that prove more liability than asset and more destructive than generative. The stakes are high. Design matters.

REFERENCES

- Abel, Chris, 2003. "Sky High: Vertical Architecture." (London: Royal Academy of Arts):17.Ibid 18, Ibid 30Adham, Khaled. "Rediscovering the island: Doha's Urbanity from Pearls to spectacle" in the Evolving Arab City: Tradition, Modernity & urban development, ed. Elsheshtawy, Yasser, (New York: Routledge,2008) :220.
- Alissa, Reem 2009. "Modernizing Kuwait: Nation-building and Unplanned Spatial Practice," Berkeley Planning Journal 22: 87-88.
- Al-Kodmany, Kheir, 2014. "GREEN TOWERS AND ICONIC DESIGN: Cases from Three Continents," ArchNet-IJAR 8: 11.
- Almutawa, Saleh, 1994. "History of Architecture in old Kuwait city" (Kuwait).
- Alves, Joana Carla Soares, and E. Umakoshi, 2010. "The Environmental Performance of Tall Buildings." (Washington, DC: Earthscan).
- Asci, Aybars and Sarkisian, Mark, 2011. "The Al Hamra Firdous Tower". (paper presented at the CTBUH 12th Conference, Seoul, October 10-12, 2011).
- Elsheshtawy, Yasser, 2004. "Planning Middle Eastern Cities: An Urban Kaleidoscope in a Globalizing World," (New York: Routledge): 178-79.
- Elsheshtawy, Yasser, 2009. "Dubai: Behind An Urban Spectacle" (Florence : Routledge) : 61.
- Gardiner, Stephen and Cook, Stephen, 1983. "Kuwait: The Making of a City," (London: Longman Group): 14.
- Mahgoub, Yasser, 2008. "Kuwait: Learning from a Globalized City" in the Evolving Arab City: Tradition, Modernity & urban development, ed. Elsheshtawy, Yasser, (New York: Routledge):154. Ibid (160-161)
- Parker, Dave and Wood, Antony, 2013. "The Tall Buildings Reference Book" (New York: Routledge).
- Ramos, Stephen and Rowe, Peter G, 2013. "Planning Prototyping and replication in Dubai" in The Superlative City: Dubai and the Urban Condition in the Early Twenty-First Century, ed. Kanna, Ahmed. (Aga Khan Program at the Harvard University Graduate School of Design):22. Ibid (25)
- Roaf, Susan, and David Crichton, 2005. "Adapting Buildings and Cities for Climate Change: A 21st Century Survival Guide." (Amsterdam: Architectural Press).
- Safran Foer, Jonathan, 2006. "Extremely Loud and Incredibly Close" (New York: Mariner Books).
- Salam, Ashraf and Wiedmann, Florian, 2013. "Demystifying Doha: On Architecture and Urbanism in an Emerging City" (Surrey, UK: Ashgate Publishing): 65. Ibid (65), Ibid (68), Ibid (70)
- Sinclair, Brian R., 2005. "Comprehension + Comprehensive: The Environmental Design of Spaces + Places" (paper presented at the The Third Conference of the Ottawa Colloquium on the Governance of Sustainable Development, Ottawa, Canada).
- Sinclair, Brian R., 2014. Somayeh Mousazadeh, and Kamaran Noori, "Change: Exploring Psychological & Sociological Constructs in the Quest for Agile Architecture & Environmental Design." (paper presented at the ARCC Conference, University of Hawaii at Manoa, Hawaii USA).
- Sinclair, Brian R., 2000. "Emptiness: Science, Spirit, and the Search for the In-Between". Keynote Address, International Symposium on the Culture of Peace, UNESCO, IIAS, Germany.
- Sinclair, Brian R., 2009. "Culture, Context and the Pursuit of Sustainability: Contemplating Problems, Parameters and Possibilities in an Increasingly Complex World. Planning for Higher Education" Journal of the Society for College & University Planning 38: 06-22.
- Smith, Adrian, 2008. "Burj Dubai: Designing the World's Tallest" (paper presented at the CTBUH 8th World Congress, Dubai).
- SOM, 2014. "AL HAMRA TOWER" http://www.som.com/projects/al_hamra_tower
- The National Newspaper, 2014 "Dubai World Trade Centre building 'an example for the future.'" [http://www.thenational.ae/news/uae-news/dubai-world-trade-centre-building-an-example-for-the-future.](http://www.thenational.ae/news/uae-news/dubai-world-trade-centre-building-an-example-for-the-future)

Contextual fields: Design methods in the construction of Lever House

Robert Holton¹

¹Louisiana State University, Baton Rouge, LA

ABSTRACT: Focusing on corporate architecture completed in New York City between 1950-1960, the following case study presents multiple influences that contributed to the final constructed building. In the United States, the post World War II decade was a time of increased prosperity and optimism. During this time, many architects were greatly influenced by a modern design idiom. Corporations were equally motivated by the era of increased prosperity and sought to develop efficient work environments to present a modern public image. Although similar in ideology, the intentions of contemporary American architecture and big business were often in conflict. Evaluated through the facets of corporate desire, design philosophy, civic regulation, and technological know how the case study looks to reveal a multitude of contextual influences.

Understanding the potential influence of architecture on an organizations structure, Lever Brothers wanted to portray a contemporary corporate environment that was also a catalyst of corporate advertising. In response to the corporations desire for an image of sparkling cleanliness, a modern building of steel and glass was proposed. The design of the all glass vertical slab was influenced by the multiple conflicted intentions of zoning ordinances, building codes, technological limits, and design ideology.

Using typical architectural conventions, plans, sections, details, building codes, and specifications, an evaluation of the following case study seeks to discover underlying organizational patterns present within the construction of architecture. The 1950's were a moment of great prosperity and changed the physical environment radically in a short time span. Both corporations and society as a whole were interested in a modern efficient life style. Often it was believed that purely physical reformations were the answer to defining a new modern environment. By looking into the case study it is evident that a single unified ideology was not able to purely direct modern intentions.

Keywords: Desire, Philosophy, Regulation, Technology, Multiple

INTRODUCTION

Focusing on corporate architecture completed in New York City between 1950-1960, the following case study presents multiple influences that contributed to the final constructed building. In the United States, the post World War II decade was a time of increased prosperity and optimism. The holistic focus of the nation seemed to be oriented towards a modern and well organized society. During this time, many architects were greatly influenced by a similar design idiom, a movement that also expressed ideals of a clean modern society. Corporations were equally motivated by the era of increased prosperity and sought to not only develop an efficient work environment but also redefine their public image. Although similar in ideology, the intentions of contemporary American architecture and big business were often in conflict. Evaluated through the facets of corporate desire, design philosophy, civic regulation, and technological advancements this case study looks to reveal a multitude of contextual influences. Using typical architectural conventions, plans, sections, details, building codes, and specifications, an evaluation of the following case study seeks to discover underlying organizational patterns present within the construction of architecture.

In 1932 The Museum of Modern Art ushered in a new period of American modernism with the exhibition: The International Style. Focused on issues of universality, modern materials, and standardized modular parts this design ideology sought to disseminate avant-garde ideals of the 1920's for mass public consumption. "The 5 points of a new architecture", promulgated by Le Corbusier and Pierre Jeanneret, in the 1927 literature published for the opening of the Weissenhof Siedlung modern housing prototypes in Stuttgart were of particular influence. The points were: 1 les pilotis (the column), 2 les toits-jardins (the roof garden), 3 le plan libre (the free plan), 4 la fenetre en longuer (the ribbon window), and 5 la façade libre (the free façade). Proposed as a progressive mode of practice, the new philosophy endeavored to reorganized post World War I upheaval and congestion. Opening the exhibition catalog, Henry-Russell Hitchcock and Philip Johnson pronounced the main attributes of the paradigm:

The effect of mass, of static solidity, hitherto the prime quality of architecture, has all but disappeared; in its place there is an effect of volume, or more accurately, of plane surfaces bounding a volume. The prime architectural symbol is no longer the dense brick, but the open box. Indeed, the great majority of buildings are in reality, as well as in effect, mere planes surrounding a volume. With skeleton construction enveloped only by a protective screen, the architect can hardly avoid achieving this effect of surface, of volume, unless in deference to traditional design in terms of mass he goes out of his way to obtain the contrary effect.¹

Understanding the impact architecture can have on an organizations structure, Lever Brothers wanted to portray not only a contemporary corporate environment for the benefit of employees but also as a catalyst of corporate advertising representing the company's products. Originating in 1885 in Great Britain, Lever Brothers was founded by the brothers William Lever and James Lever. The company was launched on the premise of a new technique to manufacture soap developed by William Watson. Both the products and business model proved to be a success and developed into an internationally recognized manufacturer of consumer goods. In the early 20th century Lever Brothers Company, a subsidiary in the United States, was established. After 1925, Levers Brothers joined forces with the Dutch company Margarine Unie in the formation of Unilever. Unilever employed around a quarter million employees by 1930 and had become one of the largest companies in Great Britain.

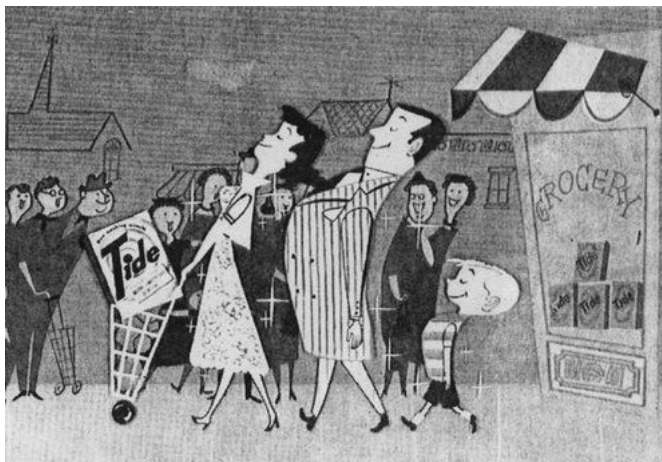

Figure 1: Tide advertisement by Ray Favata. (Source: www.pinterest.com/pin/400257485602491921/)

By 1946 Lever Brothers Company introduced Tide laundry detergent to the United States public market. A few years later the new washing soap was available across the country and quickly out paced competing products. Encouraged by the success of the detergent, Lever Brothers Company moved to New York in 1949. The following year Charles Luckman, the president of Lever Brothers Company since 1946, helped initiate the planning of a new corporate headquarters on Park Avenue in Manhattan. In 1950 Luckman resigned as president to open an architectural practice and Jervis Babb took over the leadership position of the company. Jervis Babb was familiar with modern corporate architecture from his time as vice president of Johnson Wax, the company's headquarters was designed by Frank Lloyd Wright.

In 1950 the architecture firm of Skidmore Owings and Merrill received the commission to design the mid-town Manhattan office building. Formed by Louis Skidmore, Nathaniel Owings, and John Merrill the New York City office of SOM opened in 1937, just 13 years prior to obtaining the Lever House project. The architectural team included founding partner Louis Skidmore, partner in charge Bill Brown, design partner Gordon Bunshaft, project designer Manny Turano, and design coordinator Natalie De Blois. The structural engineer was Weiskopf & Pickworth, the mechanical engineer was Jaros, Baum, & Bolles, and the general contractor was George A. Fuller Company. Located at 390 Park Avenue on the West side between 53rd and 54th Streets, the site was on a lot that measured 200' along Park Avenue, 155' along 53rd Street, and 192' along 54th Street. Programmatically the building area was just under 300,000 square feet and included 150,000 square feet of office space, a reception lobby, cafeteria, auditorium, and below grade parking. The project budget was six million dollars.

Responding to Lever Brothers desire for an image of sparkling cleanliness, SOM proposed a modern building of steel and glass. The general architectural language was defined by floating volumes accentuated by deep reveals. One volume was a horizontal free floating glass box, elevated from street level by a

recessed lobby and setback columns, that acted as a plinth which simultaneously defined the site perimeter and the void condition of the block. The other volume was a vertical free floating glass box, separated from the second level by a recessed cafeteria and setback columns, that acted as a tower which was disconnected from the existing context by large setbacks and a rotated form. The volume surfaces were made of polished vertical mullions juxtaposed by horizontal bands of green and blue glass.

The relationship of the structural columns to the volume surfaces flowed from exterior to interior as the building rose from the ground. The structure was setback and concealed behind the reflective surfaces of the horizontal and vertical volumes. It was exposed at both the deep reveals between the ground and the horizontal volume and the horizontal and vertical volumes. Set back 10 feet from Park Avenue to avoid below grade subway tracks the structure of the vertical volume was composed of eighteen columns spaced twenty eight feet apart in the East to West direction and a core along the Western edge. The composite structure was constructed of steel columns with a reinforced concrete slab.



Figure 2: Lever House photograph by Ezra Stoller. (Source: www.som.com/projects/lever_house)

Contextually, the reflective steel and glass volume surfaces contrasted with the masonry facades of neighboring buildings. Both the building South across 53rd Street and the building North across 54th Street were full block masonry masses. The incongruity between the existing traditional masonry buildings and the new glass and steel building defined a streetscape rhythm along Park Avenue that read as mass, void, volume, void, mass. As sole occupant of the new headquarters Lever Brothers was able to define a beacon for modern living supported by a specific architectural vocabulary, a glistening green tinted glass and steel envelope in striking contrast to the surrounding masonry buildings. The ambitious new structure acted as a catalyst that clearly defined a corporate identity that advertised the company's products and the lifestyle they reinforced. As Paul Goldberger noted:

New York's first major commercial structure with a glass curtain-wall (only the United Nations Secretariat preceded it), and it burst onto the stuffy, solid masonry wall of Park Avenue like a vision of a new world²

The composition of floating volumes and voids clearly defined the functions of private office space, support space, leisure space and public open space. Accessible to pedestrians, the ground level void was completely free of the usual street lining shops and reintroduced the idea of an open air plaza for public use. 75 percent of the area was devoted to pedestrians and given back to the city as public space. The ground level entry lobby was setback from the site perimeter 14' along Park Avenue and 34' along 54th Street. It was enclosed with transparent glass, and programmed as a public indoor space for exhibits. Elevated above the ground level a full block the horizontal volume was programmed with support spaces. Floating higher up was the vertical office volume. Organized around a narrow slab, each level of the free plan interior work area of approximately 6,000 square feet was all within 25' of a window to provide natural light and views. The office volume was a straight vertical slab with no setbacks. It was 53' wide x 302' high and composed of 24 stories measuring 12'4" from finish floor to finish floor. Between the horizontal volume and the vertical volume an open void was programmed with leisure spaces. This area was defined by an enclosed interior cafeteria and open exterior plaza. Elevated above the noise and congestion of the street,

the private employee plaza was oriented towards the Sothern exposure for direct natural light and views to Saint Bartholomew's Church to promote employee health and well being.



Figure 3: Lever House plans. Source: Architectural Forum, June 1952

In the early 20th Century New York was one of the first cities to establish zoning laws to regulate the quality of urban space. In a time of rapid growth and advanced construction technologies, the 1916 zoning law was established to address the increased height and mass of newly proposed buildings. The intent of the zoning law was to address issues of light and air at the public street level. To achieve this, a system of required setbacks was prescribed relative to building height. If a building occupied more than 25 percent of a site, multiple setbacks were mandated at predefined intervals as it rose in height. This formulaic system resulted in a predictably repetitive tiered wedding cake building typology across the city. The proposed office tower of Lever House, a vertical slab, was in conflict with obvious solutions to zoning ordinances that required setbacks for light and air. In response to the civic regulations, the footprint of the tower was minimized to be less than ¼ of the site. This allowed the design of the office volume to be a clean and pure vertical slab that went straight up. As Natalie De Blois recounted in her oral history interviewed by Betty Blum:

Yes, that was because of the zoning ordinance. Gordon could have gotten a bigger building . . . set back and then gone up so many feet and then set back again. Our aim in analyzing Lever House . . . was to get a building shaft that went straight up and had no setbacks. But then the shaft could not be greater than ¼ of the lot size.³

In 1929, to address the Eastward expansion of mid-town Manhattan, the zoning plan was redrawn to allow commercial use buildings along Park Avenue from East 50th Street to East 59th Street. The extra width of Park Avenue, compared to other avenues, enabled businesses to acquire properties with increased exposure and visibility that reinforced the ideas that promoted architecture as a corporate image. Historian Henry-Russell Hitchcock described the influence, modernism and corporate clients had on Park Avenue:

If he knew the Park Avenue of the dozen blocks above 46th Street as it was before 1950 he will hardly recognize the scene. Of the older landmarks, St. Bartholomew's, several hotels, the Racquet Club, and two skyscrapers, the Ritz Tower and the Grand Central Building – soon to be out-topped by the Pan American Building behind it – survive. But almost without exception the solid brick and stone blocks of the teens and twenties have been replaced by glazed curtain walls – in several cases literally so since the old internal structure has been retained. If the visitor has the curiosity to ask, he will soon learn that this change began in 1951 with the construction of Lever House, the first example of a tall curtain walled business building.⁴

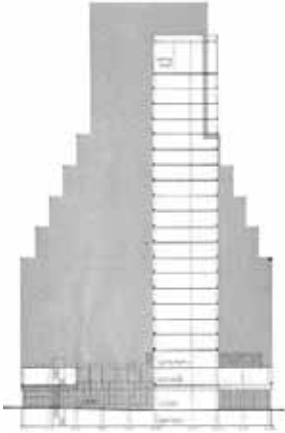

Figure 4: Lever House zoning diagram. Source: Architectural Forum, June 1952

Adhering to Lever Brother's intended image of sparkling cleanliness, the vertical office volume surface was designed as an all glass window wall system. The surface, based on a 4'8" module, was composed of 6'6" high sealed tinted green heat absorbing transparent glass, 30" high blue wire spandrel glass, and stainless steel mullions. The tint of the transparent glass and spandrel glass was drawn from the color of many of the company's iconic products. The mullions were composed of paired channel shapes sheathed in 16 gauge type 302 stainless steel. 2 1/2" wide, the mullions projected only 1" to reduce the amount of shadow cast on the glass. This allowed the window wall enclosure to appear as a smooth flush surface with minimal depth. In addition, according to the company's intent, the specified glass was highly reflective to help facilitate the appearance of a thin clean polished surface. The reflective glass was placed outside of the columns and completely obscured any indication of the structural system from exterior views of the vertical office volume in the daylight. This askew relationship between enclosure and structure seems to favor the corporate intention of self promotion over the modern design idiom of structural honesty.

As one of the earliest proposed glass and steel high-rise buildings in New York City, the design of Lever House was governed by civic regulations based on disparate building technologies and materials. The building fire codes written for masonry construction dictated the composition of the proposed all glass window wall system. Strict guidelines regulated the vertical distance and material between exterior openings. To meet these construction criteria a 4" thick masonry wall was placed behind the spandrel panels. As Natalie De Blois further recounted in her oral history interviewed by Betty Blum:

The New York City code required a distance between the top of one window and the bottom of the next window. This was why we had to have a solid wall there, for fire reasons. We couldn't actually have the glass come down to the floor.⁵

This conflict of intentions between civic regulations, technological know-how, and design philosophy resulted in the construction of a multi layered building enclosure. The enclosure was composed of a conventional masonry wall, constructed to meet code, which was then concealed by a reflective glass spandrel panel to maintain the smooth consistent surface of the floating volume intended by the design. As Paul Goldberger noted:

The glass that covers the structure between the floors, making the entire outside look as if it were made of glass –is not structural honesty at all, but merely a modernist brand of ornament.⁵

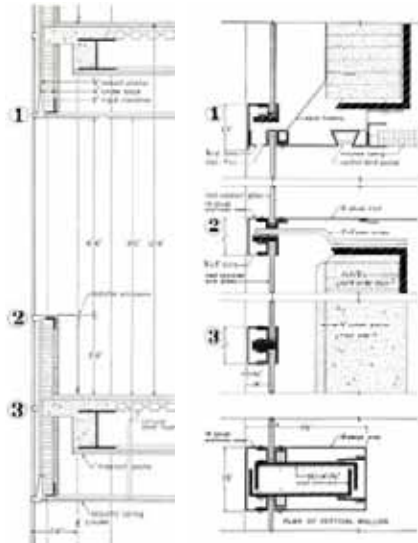

Figure 5: Lever House wall section and details. Source: Architectural Forum, June 1952

Designed to be kept sparkling clean and emphasize Lever Brother's products, the curtain wall system had varying mullion shapes to vertically guide and help deploy a new technology of mechanized window washing equipment. Otis Elevator Company produced the mechanical exterior cleaning scaffold that was stored on the roof and moved horizontally along a rail system. The entire office volume exterior could be cleaned in under 120 man hours with 2 men on the scaffold and working at a rate of 90 seconds per window. As Lewis Mumford noted:

For a company whose main products are soap and detergents, that little handicap of the sealed window is a heaven-sent opportunity. For what could better dramatize it's business than a squad of cleaners operating in the chariot, like deus-ex-machina of Greek tragedy, and capturing the eye of the passerby as they performed their daily duties? This perfect bit of symbolism alone almost justifies the all glass façade.⁷



Figure 6: Lever House window washers. Source: Architectural Forum, June 1952

With the completion of the Lever House, the modern design idiom was widely accepted by the corporate establishment. Characteristics such as curtain walls, regulating modular systems, and smooth unadorned glass and metal facades supported on pilotis became the desired norm amongst big business desiring to embrace a modern enlightened environment. As noted in Carol Krinsky's writing on Gordon Bunshaft:

Some clients chose the ostensible functionalism of modernism because it was practical; others chose it out of a heightened aesthetic sensitivity to the desire to appear progressive. "We

never had to sell modernism to anybody”, said Bunshaft. “You have to understand the time. It was a unique and marvelous thing, the situation after the war. Lots of young architects, disciples of Mies and Corbusier, had just finished their training and were anxious to do something new. At the same time, the heads of these big corporations needed new facilities and they all wanted something new-looking. I’m sure these corporate presidents all lived in colonial houses in Connecticut, but for their offices they wouldn’t consider anything but modern. They all wanted buildings they could be proud of.”⁸

The 1950’s were a moment of great prosperity and as expressed by Ada Louise Huxtable the physical environment radically changed in a time span as small as a decade:

As the old buildings disappear radical new ones rise immediately in their place, and the pattern of progress becomes clear: business palaces replace private palaces; soap aristocracy replaces social aristocracy; sleek towers of steel-framed blue, green, or grey-tinted glass give the Avenue a glamorous and glittering new look.

... The staples of our civilization – soap, whiskey, and chemicals – have identified themselves with advanced architectural design and their monuments march up the avenue in a proud parade.⁹

Both corporations and society as a whole were interested in a modern efficient lifestyle. Often it was believed that purely physical reformations were the answer to defining a new modern environment. From this case study it is evident that a single unified ideology was not able to purely direct modern intentions. The proposed vertical slab of the Lever House office tower was in opposition to the setback massing stipulated by zoning regulations. Reduced to ¼ of the site, the pure clean form of the office volume epitomized the intentions of both a modern design philosophy and corporate desire. The reduced tower footprint also provided an abundance of natural light to the interior work area. Responding to the site condition of below grade subway tracks, the 10 foot column setback from Park Avenue allowed the structure to simultaneously be shown and hidden relative to the building envelope. This duality, by allowing the structure to be concealed behind the reflective surfaces of the horizontal and vertical volumes, reinforced both the corporate image and the design intent of lightweight floating volumes. The all glass curtain wall at Lever House was deployed before the new enclosure technology was capable of addressing civic regulations based on dissimilar materials and construction techniques. Although the visible outcome appears consistent with the contemporary design ideology, the physical enclosure was limited by fire protection technology and building codes. The glass skin laid over a masonry façade, due to a conflict of intentions between city fire codes, technological know-how, and design philosophy resulted in a redundant multi layered building enclosure. At the same time, even though technology was limiting at one phase, it was the generator at another. This is exemplified through the use of the mechanized window-washing scaffold. The mechanization of cleaning the sealed glazed skin played perfectly into the corporation’s identity and product advertisement. Reviewing this case study, it is vital to note that a complex exchange of decisions, based on a multitude of contextual influences, resulted in the organization of the constructed design as compared to a deceptively simple singular explanation that is typically embraced.

REFERENCES

- Blum, Betty, 2004. Oral History of Natalie De Blois. The Arts Institute of Chicago.
“Lever House, New York: Glass and Steel Walls”, *Architectural Record*. June 1952. p. 136-141.
“Lever House Complete”, *Architectural Forum*. June 1952. p. 102-111.
“Miniature Skyscraper”, *Architectural Forum*. June 1950. p. 84-89.
Herrera, Alex, 1982. Lever House. Landmarks Preservation Commission.
Hitchcock, Henry-Russell. Johnson, Philip. *The International Style: Architecture Since 1922*. W. W. Norton & Company Inc., New York.
Krinsky, Carol. Gordon Bunshaft of Skidmore, Owings, & Merrill. MIT Press, Cambridge.
Frampton, Kenneth, 1992. *Modern Architecture A Critical History*. Thames and Hudson, London, p. 248 – 249.

ENDNOTES

1. Kenneth Frampton. *Modern Architecture A Critical History*. Thames and Hudson (London 1992), p. 248.
2. Paul Goldberger. *Architecture View: Lever House awaits the decision on it's future*. *New York Times*, November 1982.
3. Betty Blum. *Oral History of Natalie De Blois*. The Arts Institute of Chicago, April 2004. p. 48.
4. Alex Herrera. *Lever House*. Landmarks Preservation Commission. November 1982, p. 4.
5. Betty Blum. *Oral History of Natalie De Blois*. The Arts Institute of Chicago, April 2004. p. 43.
6. Paul Goldberger. *The Skyscraper*. Alfred A. Knopf. New York. 1981. p.107.
7. Alex Herrera. *Lever House*. Landmarks Preservation Commission. November 1982, p. 8.
8. Carol Krinsky. *Gordon Bunshaft of Skidmore, Owings, & Merrill*. MIT Press, Cambridge. p. 49.
9. Alex Herrera. *Lever House*. Landmarks Preservation Commission. November 1982, p. 8.

Dutch complex housing: Design for density

Julia W Robinson¹

¹School of Architecture, University of Minnesota, Minneapolis, MN

ABSTRACT: The Netherlands is world renowned for its innovative approach to dense housing. The investigation presented in this paper explores a particular form of housing, here called *complex housing*, to understand the design principles that Dutch architects and urban designers employ in its design. The paper discusses two of the nine examples that form the basis for the research. The nine projects are built between 1997 and 2010 with densities ranging from 70 units per hectare (24 units per acre) to 428 units per hectare (144 units per acre).

Complex Housing¹ contrasts with approach to density typically taken in the United States and elsewhere, in that it usually incorporates non-housing functions along with a variety of housing types, income levels, and types of tenure to create a housing project with diversity of inhabitant and a visually rich architectural expression.

The paper employs the typological approach used in the larger study to analyze two housing complexes, De Zilvervloot in Dordrecht (Atelier d'Architecture, d'Urbanism et de l'Informatique: 2005) and La Grande Cour in Amsterdam (Meyer en van Schooten, Cie and Herren 5: 2008).

KEYWORDS: Housing, Typology, Design, Density, Netherlands

INTRODUCTION

Between approximately 1990 and 2010, the Dutch government implemented what is popularly called the VINEX spatial plan². With the national government identifying where housing and development was to be located, regional governments developing the necessary infrastructure, and planners in municipal governments working with developers and architects to implement the plans, the planning process was comprehensive. The VINEX plan was designed to implement a variety of broad principles including:

- maintaining as much of green areas as possible,
- supporting transportation infrastructure (intended to increase public transportation, increase the use of bicycles and reduce automobile use), the construction of housing to be 1/3 social, 1/3 middle income and 1/3 upper income
- reorientation away from public funding toward market funding
- increasing housing for families, and addressing the need for housing especially in the Eastern part of the country or Randstad.³

This has resulted in the creation of dense housing, especially in the Randstad. The most dramatic cases for example, are in the docklands of Amsterdam for which, at the end of this period, the city required a density of 300 units per hectare (or approximately 100 units per acre)⁴. When family housing was built in these areas, it was sometimes coupled with complex housing projects to achieve the required density. The developers for complex housing projects included housing corporations, previously given government subsidies, but now asked to develop and maintain housing with their own funds. While the social housing was designed to be rented with government subsidies, the middle income and upper income housing were intended to be sold, although after the recession of 2008, often ended up as rental units.

Dutch housing is different from housing normally built in the United States for a variety of reasons. One cause is that housing regulations are based on different assumptions. For instance Dutch housing must meet higher standards for light and air than in the US that require more windows or other openings. This results in building blocks that tend to have a much narrower footprint. Also fire regulations are based less on preventing combustion and more on preventing smoke inhalation than are US requirements. Thus the United States favors single loaded corridors that can be closed to prevent access to oxygen whereas the Netherlands favors corridors with access to the outdoors between exit stairs. It is common, therefore to find single-loaded exterior corridors (or galleries) in the Netherlands.

Other sources of difference are less straightforward. Units are typically 20% smaller in size,⁵ which may be due to the scarcity of land and space in this dense country, and/or due to historical precedent. The support of housing for various income levels is somewhat experimental,⁶ but is assumed to be viable because social housing is not stigmatized in the Netherlands. In the past people living in social housing whose incomes increased continued to live in social housing and pay market rates. Therefore, unlike the United States and many other countries, social housing did not exclusively serve low-income people. Additionally, Dutch attitudes toward wealth tend to minimize differences. Likely originating in their Calvinistic traditions the

government has traditionally used tax policy to maintain a relatively small income gap between the richest and poorest citizens, and also many affluent people seem to be uncomfortable displaying their prosperity. Even manor houses built in the 17th-19th centuries are decidedly smaller than those built in other nations. Finally, the use of housing corporations (developed originally as organizations that implemented government housing policy to emancipate the working classes by maintaining rental housing) seems to have generated an orientation to creating long term value in housing. When a developer does not maintain the constructed property, as is usual in the United States, there is a tendency to use short-term investment strategies.

Since the 2008 recession the situation in the Netherlands has changed. Whereas beginning in 1900, through the VINEX period and up to 2005, the government created and implemented spatial plans every 5-7 years, no spatial plan has been created since 2005. The 2005 spatial plan represented a government move to a market-based system, and the new governments have not overseen its implementation, rather they have largely dismantled the national planning agencies. This may mean that the values represented in the housing discussed here may no longer apply to housing built more recently.

1.0 COMPLEX HOUSING

The term *complex housing* stands for a special kind of large and dense housing project⁷. Similar to what others have sometimes called *hybrid buildings*⁸ it provides moderate or high housing density while engaging other purposes as well, characteristically commercial and/or civic functions. But beyond the mixed-use characteristics typical of hybrid buildings, a complex housing project incorporates:

- Units for rental and for purchase
- Units for low, moderate and high-income residents
- Three or more types of dwelling units ((e.g. row house, maisonette, live-work unit, group home, flat, penthouse);
- Diverse organizational strategies (layers, stacking, various types of access, use of courtyards, etc.)
- Significant urban intervention
- Height predominantly 4-6 stories but sometimes including a tower of no more than 12 stories
- Outstanding architectural design

Such housing is not found exclusively in the Netherlands, but it is unusual elsewhere, and also in the Netherlands, where it is primarily found in the highly populated Western Randstad area (incorporating Amsterdam, Rotterdam, Den Haag, Utrecht and Almere) where dense housing conserves open space. Complex Housing contrasts with an approach to density typically taken in the United States and in other countries, in which a building or block is exclusively housing, made by layering multiple identical floors of flats (one-level apartments) that are lined up along a double-loaded corridor.

2.0 TYPOLOGICAL APPROACH

A typological approach is used to analyze the projects in this study. For this paper, we are examining only two of the nine projects from a larger research investigation, but employing the methodology of the wider study. In the 1970s and 1980s typology was extensively used to study differences in formal organization of both architecture and urban design.⁹ More recently researchers studying urban form and dense housing have taken a similar approach.¹⁰ Since many Dutch architects describe their design approach as based in typology,¹¹ typological analysis was chosen for its power to uncover the formal choices made by designers and reveal the design principles used to create complex housing.

The typological analysis of the study examines the following broad categories which are further subdivided as the analysis reveals more typological levels: site, massing, articulation (materials, fenestration, color), courtyard, programmatic functions, housing types (row houses, maisonettes, flats, penthouses), access, outdoor space, organization, syntactical structure.

3.0 CASE STUDIES: DE ZILVERVLOOT AND LA GRANDE COUR

The two projects selected for discussion, De Zilvervloot and La Grande Cour, while visually contrasting, and with very different histories, represent design strategies found in complex housing. While De Zilvervloot includes one of the tallest towers of the group of nine projects within its block, its density is in the middle range of the nine projects at 41 units per acre with most buildings at five or six stories. At 100 units per acre, La Grande Cour is among the three most dense projects and incorporates three 8 story towers within a six-story block. Both projects have commercial functions at the ground level and parking below ground.

De Zilvervloot was built in Dordrecht in 2005 as part of a plan to revitalize a neighborhood built exclusively for social housing in the 1960s. Woondrecht, the housing corporation that owned the buildings, needed to redesign the project to make it economically viable, and wanted to include the remaining residents in the

redesign process. The architects selected to work with the community, Lucien Kroll and Dag Boutsen of Atelier d'Architecture, d'Urbanism et d'Informatique (AUI) engaged the community in a design process that resulted in a variety of changes to the neighborhood (renovations of existing buildings, the addition of sports facilities, etc.) including the design and construction of De Zilvervloot and the adjacent public plaza on what had been open land.¹² The new building provides for a mix of income levels, about 50% social housing, 25% middle-income housing and 25% luxury units. Although naysayers were skeptical that the mix would work, the luxury housing was the first to sell.¹³

La Grande Cour was built as part of the West Docklands development in 2008. Its unusual configuration is the result of a miscalculation on the part of the developer, Bouwfonds, that was discovered by the project architects Meyer en van Schooten (MVS), when they couldn't fit the required number of units in the envelope that had been accepted by the city.¹⁴ Renegotiations with the city resulted in the insertion of three L-shaped towers called periscope towers. These provided the additional units to reach the city's required 100 units per acre density without adding additional floors to the main housing blocks.¹⁵ The schematic design by MVS included three courtyards, of which they designed one, and invited two other architectural firms, Herren 5 and Cie, to design the remaining two.



Figure 1: De Zilvervloot and the plaza to the East with entrance to the commercial courtyard



Figure 2: La Grande Cour with canal and plaza to the East and the East Periscope Tower

3.1. Siting

Both projects are located in an urban context along a main street and front on a plaza. De Zilvervloot, on a flat site, has a five story building across a street to the North but the other three sides are relatively free of impediments to light and view due to low buildings and open land to the West, and a single narrow eight story building to the South. To the West is an excellent view of the city. Because of its location in the docklands, La Grande Cour has views of water on three sides at the moment. The fourth side is on a constricted street facing an eight-story building that restricts light and view. The sloping site is addressed with change of level in the courtyards. Both buildings provide parking below grade, and access to their commercial spaces at grade. While at La Grande Cour some social housing is directly accessible at grade, the remaining units at La Grande Cour and all of the Units at De Zilvervloot are located at least one level above ground and are reached by elevator either from the garage or from ground level lobbies.

3.2. Massing

Both buildings have interior courtyards that are created by housing walls at the perimeter of the block and in the center. In both cases these walls have openings, although all of the openings in De Zilvervloot, except for the gate to the plaza, are created by a building edge, whereas in La Grande Cour the building totally surrounds the site, and most of the openings are cut within the building wall or framed by building overhangs. The smaller buildings that create the wall at De Zilvervloot are expressed by setbacks and changes in height. At La Grande Cour, the individual buildings are invisible from the exterior, and the overall block reads as one large mass.



Figure 3: The commercial courtyard at De Zilvervloot showing the opening at the North



Figure 4: An opening framed by the middle periscope building which overhangs the courtyard

3.3. Courtyards

There are two courtyards in De Zilvervloot, one is a commercial courtyard on the ground level that opens onto the street to the North with a gate to the East plaza that bring the neighborhood to the heart of the project, creating a strong integration. The other courtyard, on the first housing level above a supermarket, provides outdoor gardens for the rowhouse and maisonette units that enter from it, as well as shared open space for the entire project.



Figure 5: The residential courtyard at De Zilvervloot looking northeast toward the three rowhouses.



Figure 6: The West courtyard at De Zilvervloot with social housing on either side.

Each of the three courtyards at La Grande Cour serves as symbolic center for the dwellings that enter from it. They provide outdoor space and direct ground level access to the social housing units and to the elevator lobbies of all the other units.

3.4. Articulation (material, color, fenestration)

De Zilvervloot reads as a complex kit of parts. The base of the building is visible throughout, and the residential buildings are emphasized by changes in material, color and fenestration. On the West, North and East sides, the commercial base is expressed with a setback and use of dark brick, while on the South the residential buildings are set back from the dark brick. Although there is a consistent material palette of gray and tan wood siding, red, white and gray composite panels, and dark red brick, these are varied in such a way that the sense of the overall complex is diminished in favor of the elements that make it up. It is clear that there is also a limited fenestration palette, but this too is applied to emphasize the different buildings. The play of balconies and loggias, unique to each building adds to the visual complexity (see more below).

The purple-red brick covering the facades at La Grande Cour accentuates the building exterior as a single five-story block. Only differences in fenestration (different sizes and proportion, some outlined in white, others simply inserted into the brick envelope) and balconies suggest from the outside that the block is made up of many buildings. The slate color of the periscope buildings, close to the color of the sky, de-emphasizes these elements, thus reducing the apparent scale of the building. Within the courtyards, however, the individual residential buildings are expressed in changes of material, color and articulation and in the application of balconies and loggias. The materials on the surfaces of the residential buildings in the courtyards are shades of gray, gray-blue, and white, smooth and pale in color allowing for light reflectance.



Figure 7: Left) De Zilvervloot from the Northwest showing how the massing, color and material choices accentuate the individual buildings. Right) The massing, materials and colors at La Grande Cour emphasize the block over the individual building.

Rather than create a very tall and wide building to generate density, in Dutch complex housing the building is kept relatively low and the wall is modulated with setbacks, overhangs, materials, colors, windows, loggias, balconies and openings to reduce the apparent scale. The designs employ contrast to startle and amuse. Whether the periscope elements and asymmetrical balconies at La Grande Cour or the range of materials and colors at De Zilvervloot, the surprise engages the viewer and brings the buildings to a new level of expression.

3.5. Programmatic function

While complex housing projects vary greatly in the types of non-housing functions they incorporate (in addition to six cases with commercial space, the nine projects include such functions as clinic, library, child care and church), these two buildings are more similar than different, with their ground floor commercial base and parking below. The main difference is the commercial courtyard in De Zilvervloot that makes the commercial functions more integral to the development. In La Grande Cour the commercial space only opens to the exterior, thus making it largely external to the residential life that takes place within the courtyards. However, in both cases, the commercial activities create active street life and embed the project in the adjacent community.

3.6. Access types

The two projects, typical of complex housing, employ diverse modes of access: direct access from the street or courtyard (to row houses), access from elevator vestibules (typically corner locations), access from double-loaded skip stop corridors, and access from single-loaded corridors or galleries with these last three access types used to form walls of units.



Figure 8: Gallery Access at the commercial courtyard



Figure 9: Access galleries at La Grande Cour's East courtyard

3.7. Housing types and unit types

Both De Zilvervloot and La Grande Cour combine several different types of housing: row housing (multi-story units that enter directly from the street or courtyard, share side walls, and typically have front and rear orientation), maisonnettes (multi-level apartments), skip-stop apartments (two story apartments that enter on one level and have living spaces on another such that corridors are not on every floor), flats (one-level apartments), and penthouses (flats or maisonnettes that have roof gardens). Despite the few broad categories of housing, the number of unit types in each of these buildings is surprisingly large: around 28 for De Zilvervloot, and over 40 for La Grande Cour. In addition to the housing types shared with La Grande Cour, De Zilvervloot incorporates live-work dwellings that while not entered directly from the street, have a large living area and potential office space entered from an internal corridor, bypassing living areas. Both buildings include penthouses at various roof levels.

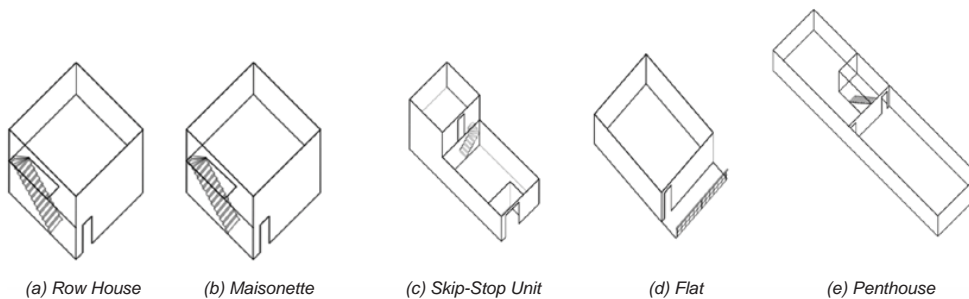

Figure 10: Housing Types Often Found in Dutch Complex Housing (drawing by Erin Lilli).

At De Zilvervloot, the predominant housing type is flats, which make up 82% of the 130 units, and are evenly distributed across buildings. Maisonnettes make up about 16 % of the units (6% skip stop), and row houses 2%. The flats tend to be vestibule-accessed (38%,) versus gallery-accessed flats at 23%. Ground accessed row houses (from the raised courtyard level) are a low 2%. In La Grande Cour the predominant housing type is also flats at about 65% percent of the 253 units, with 37% vestibule-accessed. These are located at the four corners of the building, in the low towers along the South side and as one or two units per floor in the periscope towers. Similar to De Zilvervloot approximately 25% of the units are gallery-accessed flats, but the proportion of skip stop maisonnettes that enter from a double-loaded hall is higher at La Grande Cour, at 18% each, and number of row houses is significantly higher at 18%. The remaining 2% are flats that enter from a double-loaded corridor.

In terms of the mix of housing, De Zilvervloot has a greater proportion of social housing than La Grande Cour with 50% of housing serving as social housing, and 25% each for moderate income and luxury dwellings. In contrast La Grande Cour incorporates mostly middle income housing at approximately 50% with 30% social housing and 20% luxury units.

3.8. Outdoor Space

Similar to most other complex housing projects, the outdoor spaces employed at De Zilvervloot and La Grande Cour include gardens (open spaces at ground or roof level), balconies (outdoor spaces that cantilever from the building) and loggias (outdoor areas within the building wall). At De Zilvervloot, fifteen units have gardens, and another eight units have roof gardens. These include the row houses and several units that open onto the residential courtyard, as well as flats from the South gallery access building on that same level. Units along the West, main street side have loggias to protect them from the wind and street noise. Units that open eastward onto the plaza have either loggias or balconies. Units along the South side have gardens or balconies, while Penthouses have roof gardens and/or loggias.

At La Grande Cour about 20 units have roof gardens including most of the penthouses. Most of the penthouses also have loggias. While the row houses have ground access and in theory some private space in front of the units, in fact only about six of the houses, those in the South courtyard have an area



Figure 11: De Zilvervloot from the South showing balconies, loggias (in the corner of the building to the right) and roof gardens on the lowest and penthouse



Figure 12: La Grande Cour has balconies on the North sides of the West periscope building and the East gallery building.

sufficiently protected from passersby (in this case by a planters) to be called garden space. Outdoor spaces for dwellings on the North side facing the river and the main street are loggias. Outdoor spaces that face the courtyard and the East side of the building are balconies, and on the South side facing the canal either balconies or loggias serve as outdoor spaces.

3.9. Organization

At De Zilvervloot, each of the nine residential buildings is different, but all are accessible from the parking garage or from the street. Most buildings combine either middle-income housing or social housing with luxury housing, typically at the top floor in the form of a penthouse. The Southwest tower and the two buildings along the West side are largely made up of vestibule apartments. The building on the North side facing the residential courtyard contains live-work units and gallery access maisonettes. On the East are two vestibule access buildings that contain flats. Between these is a bridge that creates the entrance from the plaza to the commercial courtyard. The bridge is made up of skip-stop maisonettes that enter from a double-loaded corridor. The building on the South side is largely comprised of gallery flats that serve as social housing with penthouses on top.

In addition to the twenty-seven rowhouses at La Grande Cour that enter directly from the three courtyards, there are nine multi-family buildings that house the remaining 223 units. These buildings are entered both from the parking below and from one of the three courtyards. The three buildings to the North, each entering from a different courtyard, form the wall along the street. These contain skip-stop maisonettes that enter from double-loaded corridors on two floors, and vestibule access flats at the corners. The South side of the complex has three towers containing vestibule-access flats. Bridging between the three towers, and entering from the West and Middle towers are two sets of gallery access flats. At the Southeast corner is a gallery access building with flats that forms the remaining South wall and the East wall. On the West side of each courtyard is the entrance to the periscope buildings. The West periscope building cantilevers toward the South over the West social housing. The Middle periscope building bridges to the North over the street wall,

while the East periscope building hangs over the East courtyard to rest on the gallery access building adjacent to the East plaza.

3.10. Syntactical Structure

Space syntax gamma analysis diagrams are used to study the syntactical structure of the housing in this project using space syntax diagrams that address the circulation spaces. The diagrams shown in Figures 12 and 13 focus on the circulation space as experienced by a visitor entering from the street.

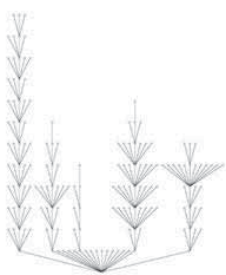

Figure 12: Space syntax diagram of De Zilvervloot (drawing by Jennifer Asp)

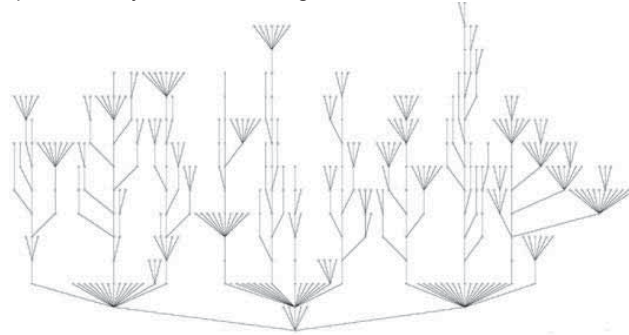

Figure 13: Space syntax diagram of La Grande Cour (drawing by Jennifer Asp)

The first visible difference between the two projects is the size of the project, with De Zilvervloot being half the size of La Grande Cour (129 units versus 253). The general pattern of the circulation in De Zilvervloot does not reveal the nine buildings that are identified from the outside, but rather five entries, some of which are shared between two adjacent buildings that read as one branch in the diagram. However, the building arrangement of La Grande Cour is evident from the diagram. We see the three courtyards with rowhouses and three or four buildings branching from them. In both buildings each branch has a slightly different pattern, indicating that the designers are addressing the unique condition of each building. The pattern of the branches in De Zilvervloot however is more regular than the branches of La Grande Cour because most floors have circulation spaces on them, and each De Zilvervloot building has a similar number of units on each level. The structure of De Zilvervloot has less hierarchy and more regularity than La Grande Cour.

In contrast, La Grande Cour has a complex, hierarchical, and apparently idiosyncratic arrangement of space. The fan-shaped patterns in both diagrams show where circulation spaces connect to a set of units. Some of the sparse branches in La Grande Cour represent the floors without circulation in the skip-stop arrangement. The fan shaped double-loaded corridor arrangement of the floors that do have unit access interrupts these branches. Other sparse branches represent the two periscope buildings that have one or two units on each level but many units at the top. The two sparse branches with fans at the very top are the periscope buildings with one flat per floor and skip stop units on the top three floors that have only one access level. The sparse branch with few units at the top is the periscope building with one building on each level and two penthouses on each of the top three floors. Here, while the hierarchy of courtyard and building is clearly expressed, the branches representing buildings each show unique patterns.

CONCLUSION

Complex housing demonstrates the potential for dense housing to be more than a tall and wide building with identical dwellings layered one on top of the other in a repetitive and uniform pattern. These projects incorporate social and programmatic diversity with a variety of formal expression. Having non-housing programmatic uses ties a project to its community. Having many different types of housing creates the potential for many different life styles to reside side by side. Dutch developers create housing they intend to maintain over time, rather than a quick turnover, resulting in wise long-term investments. The special conditions of the Netherlands may make some aspects of the projects difficult to replicate in other places, but the overall principles of mixed use, mixed housing type and lively architectural expression can be widely applied.

ACKNOWLEDGEMENTS

The research in support of this paper was supported by various grants from the University of Minnesota including the School of Architecture and the Undergraduate Research Opportunity Program. Research Assistant contributors have included Graduate Assistants Hans-Christian Karlsberg, Erin Lilli and Sean Meyers, and Undergraduate Assistants, Austin Lukes, Sean Meyers, Thomas Ducastel, Jianing Song, Yujing Su, Kristin Erhardt, Andra Zerbe, Jennifer Asp, Corinne Deger, JInguang Xie, Hayden Rensch, Brittany Klingler and Edward Palka. Photographs are by the author.

ENDNOTES

- ¹ Julia W. Robinson. 2011. "Design for density: An analysis of complex housing in the Netherlands using typology," *Continuity and change of built environment - Housing, culture and space across life-spans: Proceedings of the IAPS international network symposium*, CD Rom, Daegu Korea.
- ² The term VINEX originated from the initials of its Dutch name of the policy, Vierde Nota Over de Ruimtelijke Ordening (The Supplement to the Fourth National Planning Policy Document on Spatial Planning) (Maiike Galle, & Ettjen Modderman, "Vinex: National Spatial Planning Policy in the Netherlands during the Nineties," *Netherlands journal of housing and the built environment* 12:1 (1997), 9-35.
- ³ Jelte Boeijenga & Jeroen Mensink. 2008. *Vinex Atlas*, Rotterdam: 010 Publishers; , Maiike Galle. and Ettjen Modderman. 1997. "Vinex: National spatial planning policy in the Netherlands during the nineties," *Netherlands journal of housing and the built environment*, 12:1:9-35;
- ⁴ Ton Schaap (Urban Planner, City of Amsterdam). 2010. Interview, Amsterdam March 23
- ⁵ Julia W. Robinson. 2010. Dutch Housing and Urbanism Class research, Minneapolis, MN unpublished.
- ⁶ Rob Hagens (Director Woondrechtconsult at Stichting Woonbron). 2010. Interview and Site visit, Rotterdam, March 2
- ⁷ Julia W. Robinson. 2011, op. cit..
- ⁸ Javier Mozas. 2011, "This is Hybrid" in A. F. Per, J. Mozas & J Arpa, *This is Hybrid: An analysis of Mixed-Use Buildings by A+T*, Vitoria-Gasteiz, Spain: a+t Ediciones, 12-45.
- ⁹ Roger H. Clark., and Michael Pause, M.. 1979. *Analysis of precedent: an investigation of elements, relationships & ordering ideas, in the work of eight architects*. Student Publication of the School of Design, North Carolina State University at Raleigh. Raleigh, NC.
- ¹⁰ For example 1) Susan Komossa, Han Meyer, Max Risselada, Sabien Thomaes & Nynke Jutten (eds.) 2005. *Atlas of the Dutch Urban Block*. Bussum, Netherlands: Thoth; and 2) Javier Mozas & Aurora Fernández Per. 2006. *Densidad: nueva vivienda colectiva [density: new collective housing]* (Vitoria-Gasteiz, Spain: a+t Ediciones) 210-215.
- ¹¹ For example, Roelf Steenhuis (Principal Steenhuis Bukman Architects). 2010. Interview and site visit, Delft and Carnisselande Barendrecht, March 9
- ¹² Rob Hagens. 2010, op.cit.
- ¹³ Kroll, Lucien (Principal, Atelier d'Architecture, d'Urbanisme et de l'Informatique), 2010. Interview and Site visit, Rotterdam, March 2
- ¹⁴ Rein Willems (Northwest Netherlands Regional Director, Bouwfonds). 2010. Interview, Haarlem, Netherlands March 25.
- ¹⁵ Jeroen Van Schooten, (Principal, Meyer en Van Schooten Architecten) 2010. Interview and Site visit, La Grande Cour, Amsterdam, March 5.

Effectiveness of design standards in improving residence hall usability and satisfaction

Edward Steinfeld¹, Sue Weidemann¹, Jonathan White¹, Elyse Sigal¹

¹State University of New York at Buffalo, Buffalo, NY

ABSTRACT: “Universal design is a process that enables and empowers a diverse population by improving human performance, health and wellness, and social participation” (Steinfeld and Maisel 2012). The designers of a university residence hall utilized a draft universal design standard during their design process. The Rehabilitation Engineering Research Center on Universal Design and the Built Environment (RERC-UD) conducted a post-occupancy evaluation to determine the effectiveness of the draft standards and help inform further standard development. In this study, researchers used more general concepts of “usability” and “satisfaction” to encompass the three desired outcomes of universal design. This post-occupancy evaluation used three methods of inquiry:

1. **Guided Tours:** A trained researcher escorted participants through the new residence hall and a comparison hall while participants rated usability of specific building features. This provided a controlled environment for a quantitative response format while providing open-ended response opportunities prompted by the real world immersion.
2. **Online Survey:** Residents of both buildings answered comparable questions about usability of specific building features and general satisfaction.
3. **Archival Records:** A researcher systematically examined work orders created by residents and staff about problems they were experiencing with both buildings.

The use of multiple methods of inquiry, though challenging, leads to increased confidence in the results. While each method yields unique information, the complimentary information found in the overlapping content areas provides a better understanding of the complex issues involved.

The results provided insight into how well the two buildings suit occupant’s needs, identified which features were most closely related to resident satisfaction, and helped evaluate the effectiveness of specific universal design standards, as well as the value of utilizing such standards in practice. The findings show that participants rated the new residence hall as more usable and more satisfactory than the comparison hall. This paper will discuss the methodology and findings and identify further directions for this line of research.

KEYWORDS: Design standards, Residence hall, Usability, Satisfaction, Post-occupancy evaluation

1.0 INTRODUCTION

The primary role of architects is to design environments that are safe, usable, and meet the goals of all their target users. However, specific design decisions can create barriers for subsets of the population with unaddressed needs. Such groups include people with disabilities, caregivers, low-income people, children, and older people. These unintentional barriers could be anything from a door that is too heavy, to stairs and passageways that block access for wheelchair users and create difficulty for people with strollers and rolling luggage, to a poor room layout and numbering system that causes people to get lost. The Americans with Disabilities Act Standards for Accessible Design aims to eliminate fundamental access barriers for one special population, people with disabilities, but they do not address usability and convenience issues for the broader population. Further, while the standards provide minimum requirements to accommodate people with disabilities, they do not inform designers how to provide optimum conditions for even this group and have significant gaps, e.g. addressing cognitive disabilities. Building codes and standards focus primarily on access and egress, safety, and major health issues like sanitation. They do not address the full range of issues related to social integration, comfort, and wellness from a best practices perspective.

Built upon the foundation of accessibility, the concept of universal design addresses health, wellness, and social integration as well as higher levels of physical access, safety, and comfort provided by building

regulations. The eight Goals of Universal Design are Body Fit, Comfort, Awareness, Understanding, Wellness, Social integration, Personalization, and Cultural Appropriateness. Proponents of universal design argue that these goals are appropriate for all design projects, and architects and designers who attempt to achieve these goals will create environments that are healthier, friendlier, safer, and more usable for all people (Steinfeld and Maisel 2012). However, unlike minimum standards for accessible design, there is no single set of guidelines or standards to guide architects and designers on how to achieve the goals of universal design. While several organizations have developed informal checklists, many focus on the residential sector, and none reference evidence-based design criteria. In 2009, the Center for Inclusive Design and Environmental Access began assisting the Global Universal Design Commission to develop consensus standards for universal design of commercial buildings. The purpose of such standards is to bridge the knowledge gap by creating a single body of evidence-based universal design strategies. Experience, expert judgment, and evidence-based research informed development of the standards. Architects utilized a draft version of these standards to design a new 600-student residence hall on the State University of New York at Buffalo's campus. The standards include provisions for the design of the site, building entrances, common areas, interior circulation, restrooms, assembly spaces, sleeping rooms, workspaces, services, and policies. The post-occupancy evaluation conducted by the Rehabilitation Engineering Research Center on Universal Design (RERC-UD) presented in this paper demonstrates that user satisfaction and usability is significantly higher in this building than a comparison building designed without use of the standards. The results provide insight into how well the two buildings suit occupant's needs, identified which features were most closely related to resident satisfaction, and helped evaluate the effectiveness of specific universal design standards as well as the value of utilizing such standards in practice.

2.0 BACKGROUND

Residence halls are homes to a broad and diverse population including students with varying needs, abilities, and interests as well as university staff and visitors of all kinds. Residence halls include spaces for sleeping, eating, studying, meeting, teaching, and public programs. The wide variety of spaces and people makes residence halls an ideal environment in which to study universal design standards. While there have been post-occupancy evaluations conducted on how specific features of the residence hall environment affect student satisfaction and behavior, there are no studies that examine effect of a specific set of universal design strategies on a building's users.

Amole (2009) investigated the relationship between residential satisfaction and scale of the residential environment utilizing a survey about design, facilities, social interaction, place, maintenance, and management. Propst and Propst (1973) studied the impact of room layout on student satisfaction and behavior at the University of Massachusetts, Amherst. Van Der Ryn and Silverstein (1967) studied University of Berkeley student perception and satisfaction with their high-rise residence hall using factors such as temperature, light, and noise. None of the studies compared the effectiveness to a specific set of design guidelines. Further, no previous study has given attention to people with disabilities or any other group often overlooked in the design process.

In 2006, the University of Wisconsin-Whitewater (UWW) commenced planning a residence hall using universal design as a guiding framework (Watson, et. al 2013). However, since this was prior to development of the draft universal design standard, the designers of the UWW residence hall developed their own proprietary set of guidelines based on a document called the Principles of Universal Design (Center for Universal Design, 1997). In an article on the project, UWW acknowledged, "there are no specific standards for what [universal design] means in practice" (Watson, et. al 2013). The university's interest in universal design was to serve an increasing student population with disabilities. According to the article, the growing population of students with disabilities on campus is due to "better medicine, increased access to primary and secondary education, and the availability of adaptive technology and other resources" (Watson, et. al 2013). The university's primary goal was to eliminate barriers for students of a diverse population and to improve access, resulting in the retention of students with disabilities.

3.0 OBJECTIVES

The primary research question was to determine if a universally designed building provides a significantly better user experience than a similar building that was not. A related question was to determine if the draft universal design standards were effective in contributing to an improved experience. A third objective was to gather information to improve the draft standard and lay the foundation for a cost effective audit process. To

determine an answer to the primary research question, researchers conducted a post-occupancy evaluation of two residence halls. One residence hall incorporated many design strategies listed in the draft universal design standard. The comparison residence hall is comparable in size and student population, is generally compliant with accessibility regulations, but pre-dates the concept of universal design. The post-occupancy evaluation had three phases: a guided tour, an online survey, and a review of archival records.

4.0 METHODS

4.1. Guided tours

The guided tours consisted of a trained researcher who escorted 62 participants through the new residence hall and the comparison hall one-at-a-time. The researcher asked participants to perform various tasks using the building's features throughout the tour and to rate the ease or difficulty of such tasks. He or she also recorded the ratings of features on a seven-point Likert scale (from very easy to very difficult). The researcher also asked participants to explain the reason for their rating, recorded notes on existing conditions, and made comments based on his or her observations of task performance. The guided tour focused on usability and addressed a selected set of topics such as entry to the building, design of public areas, finding destinations, and using features and amenities in restrooms, hallways, kitchens, lounges, stairways, elevators, and sleeping rooms. Specific goals and strategies listed in the draft standard formed the basis for most questions. The structured interview and response format provided a controlled environment for a quantitative response format that an audit tool would need while providing open-ended response opportunities prompted by the real world immersion. Participants consisted of paid volunteers who did not live in either building, and who had a variety of physical and cognitive abilities and backgrounds, including 31 able-bodied people and 31 people with a mobility, cognitive, and/or visual impairment (split nearly evenly). The purpose of using non-residents was to avoid bias due to familiarity with the building and to allow researchers to gather information on the difficulty of finding destinations from a visitor's perspective, something that the draft universal design standards address.

4.2. Online survey

Residents of both buildings completed an online survey. The survey questions were similar to those used in the guided tour methodology in order to allow a comparison between the techniques, but the online survey also addressed satisfaction with building features and issues that required familiarity with the building to make meaningful judgments, e.g. thermal comfort. The online survey used a five-point Likert scale asking participants to rate their level of agreement with a positive statement about the building's features (from strongly disagree to strongly agree). While the guided tour questions focused primarily on the ease of use of completing tasks using the building's features, the online survey asked residents to evaluate specific features in their residence hall in terms of their satisfaction, safety, and comfort. The online survey addressed private areas within the halls (e.g., resident's rooms or suites), shared spaces (e.g. lounges, bathrooms, laundry areas), and public spaces (e.g., first floor lounges, eating areas, etc.). Specific goals and strategies listed in the draft standard formed the basis for most questions. The survey also included a set of more general evaluations of the residence halls, such as overall maintenance, safety, comfort, and satisfaction. To ensure survey availability to respondents with visual impairments, researchers ensured the hosting website was compatible with screen reader software and other accessibility standards.

4.3. Work orders

Researchers systematically analyzed building work orders for both residence halls. The purpose of the analysis was to determine if there were any issues not identified by either of the other two methods. The work orders consisted of written complaints by students and staff about various problems and issues within the buildings. This analogous assessment of the issues or concerns raised by the guided tours and the online survey provided researchers with the opportunity to explore new issues and to investigate known issues further. For example, the qualitative portion of the survey identified a problem with frequent tripping of circuit breakers, but researchers did not realize the extent of the problem until the work order analysis revealed that this issue accounted for 37% of all work orders. The work order results also provide insight into typical problems facing a new building, in contrast with an established building, which will aid in the refinement of the universal design standards for facilities management.

4.4. Presence or absence of universal design strategies

Finally, to determine if the draft universal design standards were effective in precipitating the user ratings, researchers had to determine which universal design strategies in the draft standard were included in both buildings. The draft universal design standards contain over 600 strategies and designers can choose which strategies they want to include to meet universal design goals. For example, the standards includes the goal,

“Doors are designed to facilitate understanding of their operation and are easy to use.” To achieve this goal, it lists strategies such as, “Frames and doors have contrasting color from adjacent walls,” “Push side and pull side are coded for ease of use,” and “clear width allows all personal wheeled mobility devices to pass through,” and others. The building may have used one or more of these strategies but all would affect ease of use. Thus, it is important to understand which strategies contributed to the ratings.

Researchers compiled a list of the universal design strategies to investigate in both buildings since it was possible that the non-universally designed building could have individual strategies consistent with the universal design standard. However, researchers discovered that some strategies were worded in such a way that they were open to interpretation making it difficult to determine which strategies actually existed in each building. To make this determination, a researcher and two colleagues completed an independent assessment of each building using a checklist of strategies. The level of agreement among the assessors was also determined for each item to ascertain the extent of consensus on the presence of each universal design feature. Researchers compared the assessors’ ratings for each building and developed a level of agreement score based on how far apart the assessors were on the five-point rating scale. If experts did not agree on the existence of the same strategy in both buildings, the strategy was not included in the analysis since the wording of the strategy was likely unclear. This analysis identified three categories of strategies: (1) strategies that were more prominent in the universally designed building, (2) strategies that were more prominent in the non-universally designed building, and (3) strategies that were of equal prominence in each building. Once the strategies list was reduced to only those where there was general agreement in the existence of a strategy in at least one building, researchers compared the average assessors’ rating for each strategy, for each building. Then, for each strategy, the researcher marked which building had the higher score, or if the scores were even.

5.0 RESULTS

5.1. Building comparisons

Researchers paired the guided tour items from each building. While there were items unique to each building, only those that are present in both buildings are included in this analysis. For example, each building had a restroom with door and toilet, thus researchers asked the same questions about these features in each building. Each building tour included a way-finding task, in which researchers instructed participants to find a room based on its room number. Conversely, only one building had a business center; thus, this analysis does not include any questions on the business center. Researchers designed the tour for each building to be as similar as possible to facilitate these comparisons. Similarly, the online survey for each building was nearly identical save word substitutions to match each building’s internal nomenclature (e.g. “floor lounge” substituted for “entertainment lounge”).

After pairing the questions, researchers computed average ratings for each item for each building. Analyses were also completed by gender and self-reported functional limitations, defined here as “disability.” Thus, for each question, in each building, there is an average rating for five samples: the total sample, all males, all females, all non-disabled people, and all people reporting at least one disability. The objective for each of these samples was to compare the two buildings. Researchers used a two-tailed paired samples t-test to compare the two buildings for the guided tour data, and a two-tailed independent samples t-test for the online survey building comparison.

The universally designed building rated significantly higher than the comparison building on 88 items (guided tour and online survey combined). The comparison building rated higher on only 5 items. There were no significant differences between the buildings for the remaining 41 items. These results indicate that the building designed to meet the draft universal design standards does in fact provide a better experience across many measures. Table 1 shows these results for the total sample, gender, and disability.

Table 1: Number of items with significant differences ($p=0.05$ or better) by gender, and ability level

	Items in Online Survey			Items in Guided Tour		
	UD Rated Higher	Non-UD Rated Higher	No Significant Difference	UD Rated Higher	Non-UD Rated Higher	No Significant Difference
Full Sample	56	2	27	32	3	14
<i>Male</i>	34	3	48	30	2	17
<i>Female</i>	55	1	29	25	5	19
<i>Disability</i>	20	1	64	25	3	21
<i>No disability</i>	56	2	27	27	6	15

The results were generally consistent by gender and ability level on the guided tour. However, in the online survey, questions answered by residents with a disability were less likely to result in a significant difference between buildings but this is possibly due to low sample size, since many residents did not have a disability. Another factor is the type of disability. In the online survey, researchers did not differentiate between individuals with a severe physical or sensory disability, (e.g. inability to walk or see) or a less severe cognitive disability (e.g. dyslexia). The online survey also indicated that there was a higher prevalence of significant differences among females. Since sample size is not the issue in this case, perhaps females are more sensitive to their living environments than males; however, exploring this finding requires further analysis. The open-ended responses in particular, may further explain this difference.

5.2. Effect of draft standards

To determine if there is a relationship between the number of universal design strategies incorporated in each building with the participant ratings for each item, a statistical analysis would be most conclusive but is not yet complete. However, researchers conducted a preliminary analysis to examine this issue. For this analysis, researchers identified the prominence of the strategies (universal design features) related to the items used in the guided tours and online survey – whether the strategies were implemented and to what degree. All items in which there was a significant difference in results between buildings were ranked and compared to the prominence of universal design features. While this preliminary analysis cannot definitively prove a relationship between the number of standards used and the ratings for each question, it provides an indication that one may exist, and confirms the value in additional statistical analysis, which will be complete soon.

Table 2 provides an analysis of the degree of presence of universal design strategies in comparison to the ratings from the online survey and the guided tours. Researchers identified 225 instances where a particular strategy incorporated in the building also corresponded to an online survey item. There were 408 such instances corresponding to a guided tour item. Note that many strategies may apply to a single item in the survey or tours, and many items use the same strategies as other items. For example, a restroom could incorporate many universally designed strategies, and some strategies such as those relating to the door could apply to other spaces. Thus, for each item in the survey or tour, the number of strategies incorporated into each building can be computed on an item-by-item basis as a percentage of possible strategies that were adopted. For example, one item may have 20 related strategies. If only 5 of those are incorporated in a building, it can be represented by a percentage of 25%. Alternatively, if 15 are incorporated, it can be represented as 75%. The researchers computed the presence of universal design strategies using the process described in the methods section and then calculated the incorporation rate for each item in the survey or tour. Overall, 41% was the mean “incorporation rate.” Table 2 compares the user ratings of items above or below that level. The table shows that at least twice as many items above that level had significantly higher participant ratings in the universally designed building. Therefore, there appears to be a strong relationship between the presence of universally designed features and a positive user experience.

Table 2: Number of items with significant differences (p=0.05 or better) by presence of universal design strategy

<i>Frequency of UD Strategies</i>	Items in Online Survey			Items in Guided Tour		
	UD Rated Higher	Non-UD Rated Higher	No Significant Difference	UD Rated Higher	Non-UD Rated Higher	No Significant Difference
<i>% higher than mean</i>	15	0	4	19	2	6
<i>% lower than mean</i>	9	1	11	6	1	7

CONCLUSION

The universally designed building provided a better user experience than the comparison building on many measures, which confirms the hypothesis that universal design provides a better user experience for all in terms of usability and satisfaction. It appears that it is possible to establish a relationship between the use of specific universal design strategies and user ratings. Such a relationship would be useful for providing guidance in prioritizing strategies, especially in terms of developing a certification program based on the universal design standards (e.g. LEED).

The research collected much more data than is presented here and further analyses are ongoing. In particular, an item-by-item analysis is necessary to identify the value of each guideline and strategy. The details of the open-ended responses and work orders will also provide information useful for clarifying the results of the online surveys and guided tours. Future articles will focus on further comparisons between different user groups. For example, the finding that women rated the universally designed building higher than the comparison building on many items more often than men do, suggests that further investigation of gender differences would be valuable as well.

The multi-methods approach proved to be very informative. Information from one method often provided clarification of results from another method. For example, an analysis of building work orders provided an explanation for unexpected conflicts between guided tour results and online survey results. Furthermore, results from the use of multiple methods revealed the importance of studying usability in relationship to other design goals such as sustainable design. It also led the research team to rethink the standards to make the strategies clearer and easier to identify. Future research should focus on analysis of the relationship between specific universal design strategies and user ratings. Such attention will provide the guidance necessary to inform improvements to the universal design standards.

In conclusion, this research will provide insight into the value of universal design standards and certification programs for improving the quality of the built environment for all people.

REFERENCES

- Amole, D. 2009. "Residential Satisfaction and Levels of Environment in Students' Residences." *Environment and Behavior* 41(6): 866-879.
- Center for Universal Design 1997. "The Principles of Universal Design." Version 2.0. Raleigh: North Carolina State University.
- Propst, R. and C. Propst 1973. "The University of Massachusetts dormitory experiment." Ann Arbor, MI: Herman Miller Research Corporation.
- Steinfeld, E. and J. Maisel 2012. "Universal Design: Creating Inclusive Environments." Hoboken: John Wiley & Sons.
- Van der Ryn, S. and M. Silverstein 1967. *Dorms at Berkeley: an environmental analysis*, Center for Planning and Development Research, University of California.
- Watson, E., F. Bartlett, C. Sacks, and D. L. Davidson 2013. "Implementing Universal Design: A Collaborative Approach to Designing Campus Housing." *Journal of College & University Student Housing*.

Fast houses in the United States

Lisa M. Tucker¹

¹Virginia Tech, Blacksburg, VA

ABSTRACT: John Brown, University of Calgary, has likened residential design in North America to the fast food industry.¹ The emphasis on mass production made easy and affordable, albeit not necessarily good, has led to the current landscape of domestic buildings. To understand how and why this situation developed in the US specifically, requires an understanding of the history of the profession, architectural education and culture. This paper discusses the many contributing factors that led to the current reality of house design and construction in the U.S. This industry that accounts for roughly 65% of the gross domestic product in North America or \$354.8 billion dollars and, as such, it is a significant component of the national economy, is outside the domain of trained designers.² The only way to impact this—assuming one seeks to do so—is to understand the complexities that led to the situation in the first place. As a result of the manner in which most houses are designed and constructed, the single-family house design sector has not benefited from the exploration of new materials and methods and extensive research that commercial buildings have in the past. The first part of the paper discusses the history of the architecture profession in the U.S. The second section outlines the debates surrounding architectural education in the U.S. as the first programs were developed.

KEYWORDS: Single-family, Houses, Architecture, History

INTRODUCTION

This paper explores the relationship of the architecture profession to the history of single-family house design in the U.S. between the founding of the profession and the early 20th century. The paper addresses the history of the architecture profession, the founding of the first professional organizations and the resulting definition of “Architecture” which impacted the role of the architect in single-family house design.

1.0 BACKGROUND

1.1. History of professional architects in the U.S.

Several scholars have studied the history of the architecture profession in the U.S. All seem to agree that the early roots of the profession date to Benjamin Henry Latrobe. The traditionally accepted view is that there were three types of early designers—the untutored folk builder, the master builder, and the gentleman architect—although the line between these paths was not always clear.³ Further, printed sources were available long before the architecture profession became established in the U.S. This created a fertile environment for confusion about who was required in order to design a house.

Scholars have characterized residential design prior to the Civil War as a predominantly non-architectural activity.⁴ As architects began to define their own profession (as distinct from builders and plan book writers) they made some inroads to house design but the longstanding tradition of not needing a trained design professional was firmly in place and few would-be homeowners saw the need to hire an architect to design their homes.

Latrobe, the first professionally-trained architect in the U.S., hailed from England in 1795 and became a friend of Thomas Jefferson’s. Despite their relationship, Latrobe criticized Jefferson as an architect from books without professional training. Latrobe set up the first professional architecture practice in the U.S. and plotted a course for architects that still impacts the profession today. Chief among his contributions to the profession include an emphasis on monumental projects, a focus on professionalism and charging for one’s designs and time, and a disdain for the untrained architect and builder.

Educated in England, Latrobe brought with him strong ideas about the architectural profession. These included a sense of the “superior and comprehensive character of his acquired architectural knowledge, asserting that it was qualitatively and quantitatively distinct from both his client’s taste and the practicing builders’ experience.”⁵ In 1806, writing to his pupil Robert Mills, Latrobe outlined what he considered to be the main points of the profession: the marketable skills of an architect are his time and ideas; an architect had a comprehensive knowledge of construction and design; management and supervision of a project must be separated from construction; an architect should have complete control of a project; an architect must always charge for his time; and drawings were the intellectual property of the architect. Despite his words, Latrobe did not always obtain the fees that he would have liked and his projects inevitably ran over budget, as he had little understanding of the cost of building or the American economic system. Latrobe focused on

public projects doing work for the U.S. Capitol, the Virginia State Penitentiary, the Baltimore Cathedral, and other large public projects.⁶

Latrobe's writings on professionalism and his own mentorship of young American architects left a lasting imprint on the architecture profession. To this day, many architects vehemently oppose any compromise that might endanger their design. Furthermore, American Institute of Architects (AIA) contracts retain the architect's ownership of drawings. Latrobe's early efforts to distinguish the trained architectural professional from the common builder foreshadowed the development of the profession in the post-Civil War period. Under his tutelage, the next generation of architects, including William Strickland and Robert Mills, followed in the tradition of focusing on public projects and the professionalism of architecture.

Historians describe Latrobe as arrogant, inconsistent, and temperamental. Clients often fired him for going over budget. Ironically, many other European transplants to the U.S. seem to have embodied similar difficult personalities. Steven Hallet (ca. 1760-1825) disagreed with William Thornton on the U.S. Capitol, and, disobeying orders, was fired. Pierre L'Enfant's (1754-1825) legendary "sharp tongue and high fees alienated clients."⁷ According to Mary Woods "architects found it difficult to accommodate their attitudes and working methods to an American building market dominated at one end by builders and at the other by a few master artisans and gentleman architects."⁸ Despite their somewhat troubled careers, these early architects left an indelible mark on the public's perception of architects as difficult and on architectural culture where it is preferable to defend the integrity of one's idea over pleasing a client.

Strickland and Mills were among the twenty-three architects who formed the American Institution of Architects in 1836.⁹ While short-lived as an organization, these early efforts led to the development of a formalized system of architectural office training and ultimately architectural licensing. As proponents of public commissions, little attention was given to domestic design.

Architects in the U.S. struggled with how to position themselves within a democracy. Some early architects allied themselves with social reform seeing architecture as having the ability to affect human behavior and the good of humanity. Alexander Jackson Downing and Andrew Jackson Davis allied taste with social class (although at the same time opposed a class structure in the U.S.) They believed that using tasteful design could influence the neighbors and thus spread good design.¹⁰

Unlike their counterparts in Europe, American architects had to market their services and convince potential customers why they should be hired when, by all appearances, contractors were providing "design services" for free. Motivated by this and the expressed need to "protect the public" from the unqualified, mid-western architects fought for licensing and eventually registration laws although architects in the east did not embrace this notion at first. The division between east and west continued to haunt architecture's "unified voice" throughout the nineteenth century and well into the twentieth.

Architects in the U.S. have always struggled to educate the public about their value. As architects tried to identify their own professional knowledge in the nineteenth century, they segregated themselves from builders and craftsmen, much as Latrobe had sought to do when he first arrived in America. Concurrently, builders and craftsmen developed a tradition of manuals that instructed up-and-coming builders in construction, particularly residential. Simultaneously, communities of builders developed construction cost information and did not want to share it with architects.¹¹ As a result, a large share of domestic design fell to builders. Builders knew how to construct houses using readily available wood and their instruction manuals showed framing methods and designs. Additionally, architects failed to convince the consumer of the need for a professional architect. Consequently, architects involvement in domestic design tended to be relegated to the design of one-of-a-kind houses for the wealthy.¹² Despite architects' best efforts, the general public did not feel the need for architect-designed houses. Dell Upton summarizes the situation as follows: "Finally, and importantly, clients were unwilling to grant architects control of such an important aspect of everyday life as the design of their houses."¹³

Throughout the nineteenth century, architects in the U.S. attempted to differentiate themselves from builders and raise their own prestige. One of the ways in which this was done was to establish oneself as a gentleman, architect, and artist. Latrobe first used this approach when he stationed himself as equal to his clients. Ithiel Town and A.J. Davis followed suit. Another route was an artistic pedigree like Richard Upjohn. Richard Morris Hunt attended the Ecole des Beaux Arts in Paris in an effort to legitimize his training.¹⁴ By attending the Ecole, architects could easily claim design knowledge not available to a builder.

As the profession developed, so did building codes and legislation. One of the primary outcomes of these developments during the early twentieth century was that architects were not granted a monopoly over design services. Engineers, and eventually other design professionals, were granted equal rights under the law to provide stamped drawings for new buildings. This lack of monopoly has since allowed other professions—interior design, residential designers, contractors and developers—to take away market share

of building design in the U.S. Today, *the International Building Code* uses the terminology “design professional” which can be interpreted by each jurisdiction.¹⁵

By the time architects united to advocate for licensure, the system of a client working directly with a contractor to build (and design) his single-family home was firmly established. While architects fought for registration, they focused on those they viewed as competitors—engineers and contractors—for public buildings. Latrobe’s legacy impacted professional associations and the emphasis on public work, an arrogant and inflexible attitude, and an assumed superiority over the trades. The Ecole education of many AIA members then reinforced these notions and was integrated into the first architecture curricula. Because single-family house design was not viewed as “Architecture,” architects exerted little effort on behalf of house design. As a result, by 1938, members of the AIA estimated that architects designed only 2% of the houses being built.¹⁶ The 2007 U.S. Census attributed 83% of homes built in 2005 to merchant builders.¹⁷

This situation led to fertile conditions for the residential building industry without architects. While architects fought to educate the public and establish themselves professionally, builders simply gave people what they wanted: cheap and easily obtainable houses. Builders provided designs and methods, had well worked out budgeting and could show a potential homeowner a variety of built houses. Anyone could pick up a hammer and train himself to build houses. Technical design expertise was not required to work with wood. Architectural services were not required for house design or for structural purposes. As building codes became established around the country, they contained footing sizes, load guidelines, span tables for various species of wood for floors and roofs, and other information a builder could use to figure out structural issues. Coupled with the builders’ own resources—pattern books, magazines, and other builders—architects were not needed in either the design or construction process.

The ways in which architects sought to distinguish their profession ultimately relied on education (both theoretical and technical) and experience. In the mid-nineteenth century the focus was on the science of architecture with an emphasis on technical aspects of design. With architects training at the Ecole des Beaux Arts a focus on the art and design of architecture surfaced. Using an understanding of history, theory, structures, and the principles of design—architects attempted to inform the public about the services they could offer. In the tradition of Latrobe, these efforts centered on monumental public buildings, with little interest in single-family house design for the masses. Wright explains: “...there was the implicit dismissal of most domestic architecture as too lowly for professional consideration. The profession would favor theory over practicality, theoretician over user, monument over common building, as well as man over woman.”¹⁸

1.2. History of architecture education in the United States

The training of an architect has been a subject of conversation and debate since Latrobe. Many authors have written about the history of architectural education in the U.S. with some positing a tri-partite division for architectural design education in the period prior to the Civil War. These three pathways to becoming an architect included the gentleman architect, the carpenter architect, and the trained architect. Three well-known examples of these types include Thomas Jefferson, Asher Benjamin, and Benjamin Henry Latrobe. Asher Benjamin, of the carpenter tradition, wrote “how to” pattern books for designer-builders. Benjamin learned his trade on the job and from other books. Thomas Jefferson designed buildings, not as a vocation, but as a side-interest and was self-taught from books. Although the distinction between these three paths was actually far less clear, these three scenarios provide a rudimentary model for the early education of an architect.

Formalized education for those interested in building design and construction took place on a regional level. In Philadelphia, like in other major cities of the day, local builders and architects formed institutions to disseminate knowledge about building and design. The first two of these, the Carpenter’s Company (proposed 1804-1805) established in 1833 and the Franklin Institute, 1824-1923, offered night classes to working people. The Franklin Institute catered to “mechanics”—the name often used for architects of the day—and stressed mechanical science. Architects William Strickland and John Haviland taught at the Franklin Institute. The Carpenter’s Institute, on the other hand, was formed in an effort to help builders compete for work. Owen Biddle, a carpenter-builder, taught there to a clientele consisting of carpenters and builders.¹⁹ The lack of distinction between builders and architects was evident in these early programs and the training needs of each group led to a proliferation of schools.

What the Philadelphia example provides is a lens through which the murky boundaries between architecture, engineering and building construction in the nineteenth century can be seen. Additionally, the many programs demonstrate the desire among architects and builders for knowledge about design and construction, the natural outcome of which was the development of academically-based architecture and engineering programs which arose later in the nineteenth century.

A university-based architecture curriculum was the topic of discussion among many architects in the late nineteenth century. *The American Architect and Building News (AABN)* was a key publication for architects

during this time and devoted much of the discussion to architectural education and training. The articles within the *AABN* ranged from a general discussion of the components of an appropriate education to a critique of the systems in use in France, Germany and England as well as the curricular specifics about the new programs in the U.S.

The system in France was centered on the Ecole des Beaux Arts. Arthur Drexler's seminal work on the architecture of Ecole des Beaux Arts outlined the history of the Ecole and its primary emphasis on the plan and the monumental building.²⁰ In "The Teaching of Architecture of the Ecole des Beaux Arts," Richard Chafee outlined the history of the formation of the Ecole. Originally formed in 1617 under the King of France, the purpose of the Academy (the former name for the Ecole) was to increase the King's glory through work on royal buildings. The King appointed the members of the Academy who were then elevated to the level of philosophers from mere craftsmen.²¹ The end result was that the making of the building was separated from the philosophy and drawing of the design. The Academy, and later the Ecole, focused on drawing as the preeminent skill of the architect.

The Academy sought to outline the universal principles of architecture under its first leader, Francois Blondel. These principles stressed the rules of proportion, the five orders, Roman antiquities and buildings of the Italian Renaissance.²² J.F. Blondel added French Classical Architecture to this list.²³ Students were encouraged to study classical details as inspiration for contemporary buildings. While the original curriculum of the Academy did not emphasize construction, a shift occurred in the latter part of the eighteenth century adding the study of Gothic buildings and Greek ruins.²⁴ Gothic cathedrals provided a clear understanding of building structure. This emphasis on many historic styles characterized the Beaux Arts education as received by American architects in the nineteenth century.

Of particular impact to the profession of architecture in the U.S. and to the system of architectural education as it relates to the design of single-family houses were the project types assigned at the Ecole. During the first class, students received design assignments for schools, museums, hotels, theaters and large country houses and manors. The "equisse" problem focused on a small space such as the entry to a palatial hall, a boutique, or a clock tower. The Grand Prix, or final problem, included projects such as an addition to a grand palace, a façade design "equisse" problem, and a monumental public building assignment for a museum, hospice, an embassy building, or university or other building of higher education.²⁵ Students were trained to work on large buildings particularly those associated with the King and his royal holdings.

The Ecole had a lasting impact on the education of an architect and the practice of architecture in the U.S. First, the project types assigned by the Ecole are the same types still used in architecture studio classes and preferred by most architects in the U.S. Second, the atelier model parallels that used within the studio format of education in the U.S. Students are assigned to specific studio groups and are led by a master architect (a design educator) through a project which is then critiqued by a formal jury process involving educators and professionals. Like at the Ecole, entry into architecture programs is highly selective. An emphasis on drawing and theory separates the architect from the craftsman.

The German system of educating an architect relied heavily on the technical aspects of building. In the *AABN*, one critic described the system as "scientific, hard, barren and formal."²⁶ The educational system in Germany was state sponsored and under government control.²⁷ No one was permitted to be a full time teacher because of "the tendencies to pedagogic degeneracy, often said to characterize men who give all their time to teaching, is justly feared."²⁸ Thus, all teachers of architecture also practiced.

By contrast the English system was a great deal looser. Individual masters set up their own training offices and acquired apprentices. The training varied greatly from one person to the next with no consistent way of becoming educated as an architect. The writers of the *AABN* disparaged the English system stating in 1879 "There is no such thing as an English architectural curriculum. There has never been even a serious attempt in England to establish an architectural school of any importance, we believe; certainly no such school exists."²⁹ During the late nineteenth century, many English architects called for a formalized system. While the Royal Academy began offering some courses in 1808, the first full-time program was formed at Kings College under Sir Bannister Fletcher in 1892.³⁰

Of the three European models—the Ecole de Beaux Arts, the English system and the German system—the American educational system most closely aligned itself with the Ecole. An *AABN* article comparing the German system with the English once, found both systems lacking. "It is contended that it is precisely those features of the German training that critic (Herr Reichenspberger) most disparages, that the English architects feel they are most in need of."³¹ The German system was criticized by the writer as overly technical and focused on teaching one historic style while the English system was praised for fostering creativity and freedom. While critics and writers occasionally referred to the other two countries' approaches to training architects, the main focus of discussion centered on the Ecole des Beaux Arts. Despite its popularity and overall acceptance as a model for academic programs in the U.S., some critics also complained about Ecole methods of training: "In nearly all the schools which ape the Ecole, a vast amount of

time is given to the matter of academic rendering, I wish I knew just what this training is supposed to accomplish.”³²

Despite the occasional complaint, the Ecole methods informed most of what eventually took place in early academic programs. Furthermore, the editors and writers for the *AABN* tended to agree with the focus on drawing and historic stylistic prototypes promoted by advocates of the Beaux Arts. In 1879, one contributor said: “The pencil (or the brush) is the architect’s chief educational reliance...”³³ Throughout the late nineteenth and early twentieth century’s, the *AABN* presented contemporary information about architectural education.

The call for formalized architectural education paralleled the rise of professionalism in the nineteenth century. Clason Weatherhead divided architectural education before 1941 into three distinct periods: formation of early schools, “demonization” of the principles of the Ecole des Beaux Arts, and the “Modern” style.³⁴ The first architectural programs established in higher education dated to the period following the Civil War: Massachusetts Institute of Technology (MIT) in 1868, Cornell in 1871, and the University of Illinois in 1873.³⁵ Like the *AABN*, Weatherhead identified two sources for architectural education in the U.S: the Ecole des Beaux Arts and the educational systems of Germany and England.³⁶ Weatherhead’s dissertation stated that architectural education in the U.S. owed its theoretical roots to the French system.³⁷

In his summary of the early period, Weatherhead points to wide variation among the earliest schools, although the Ecole impacted each profoundly. The key courses of the curricula included courses on design, construction (albeit cursory), the history of architecture, drawing, and other academic subjects with an emphasis on the design studio as the central experience.

The second period of architectural education was a period of eclecticism. Weatherhead summarized it in eight predominant characteristics: (1) dominance of eclecticism and the Beaux Arts, (2) emphasis upon theory and unreality, (3) little encouragement of creative ability, (4) lack of integration among the subject groups, (5) design the important subject, (6) professional ethics stressed, (7) lack of instruction in the business phases of architecture, and (8) and lack of transition between the school and the office.³⁸ It was during this period that many schools of architecture were formed across the U.S. Firmly rooted in the Beaux Arts methods and tradition, these schools educated the next generation of American architects.

By 1894, the Society of Beaux Arts Architects had been formed in the U.S. with seventy-two members. Alumni of the Ecole were added to the faculty of MIT, Pennsylvania, Cornell, and Columbia all of which were subsequently reorganized incorporating atelier style studios. The majority of early programs were located in the northeast (seven) with two in the Mid-west. By 1911, eleven additional programs had been established. Forty-seven programs existed by 1947. “The Society of Beaux Arts Architects failed to secure the establishment of a national school, but it won an even greater influence on American architectural education as the use of its design competitions reached national scope.”³⁹

A slightly different view of the history of architectural education in the U.S. is provided by “Patterns of Education for the Practice of Architecture” as included in the 1954 report conducted by the American Institute of Architects entitled *The Architect at Mid-Century: Evolution and Achievement*.⁴⁰ The AIA report differentiates architectural education in the U. S. from its European counterparts. As a part of the American university system, architectural education incorporated a well-rounded liberal arts education that surpassed that of a technical school. One of the legacies of this approach has been a separation between education and practice that has made the transition from one to the other notoriously difficult for graduates.

The AIA report presents an overview of the first decade following Weatherhead’s dissertation work, the post-1941 period. Early interest in the “International Style” and the work of the Bauhaus increased substantially with the hiring of Walter Gropius at Harvard University in 1936. “Although the Bauhaus point of view naturally prevailed, the result was nevertheless a new phenomenon, for it operated within the American collegiate system.”⁴¹ Two years later, Mies van der Rohe was appointed to head the school of architecture at Illinois Institute of Technology, expanding the Bauhaus influence on architectural education in the U.S.⁴² The Bauhaus workshop tradition with both teacher and student working together was integrated into the established studio system. This Americanized-Bauhaus approach continues to have influence over the structure of architectural education in the twenty-first century at some schools in its modified form. Many programs have established shops where students and faculty can participate in the “making” of architecture.

Subsequent studies of the profession have been conducted. These include “A Study of Architectural Schools 1929-1932” conducted by the Association of Collegiate Schools of Architecture (ACSA), the AIA report on the Architect at Mid-Century, the “Architecture Education Study” also known as the Princeton Report, the 1967 “Study of Education for Environmental Design” also known as the MIT Report, Robert Gutman’s work on the profession from the mid-1980s, and Mitgang and Boyer’s 1996 report. Many of the issues which first plagued the profession—an emphasis on theory versus practical matters, disagreement over the art or

science of architecture, alienation with other disciplines and territorial disputes, and studio versus lecture classes—continued to be identified.

CONCLUSION

The history of the development of the profession up to the time of the Industrial Revolution resulted in a reduction of responsibility coupled with a sense of elitism and need for large public projects most often associated with church or state sponsorship. The profession has proceeded to progressively lose additional areas of knowledge to others: site design to landscape architects and civil engineers, structural design to engineers, mechanical, electrical and plumbing to mechanical electrical and plumbing engineers, and the design of interiors to interior designers. This has occurred in practice and has been institutionalized through American Institute of Architects' contracts and legislation in the U.S.

It is undeniable that many architects in the U.S. have been engaged in single-family house design. Furthermore, some members of the profession have thought it is their moral duty. Generally speaking, however, single-family house design falls into two categories: single commission for the wealthy or utopian vision. In the former case, the design is for a specific, often wealthy, person with a specific site. The examples of this type are numerous and iconic and include many projects by Frank Lloyd Wright, the Glass House by Phillip Johnson, the Farnsworth House by Mies Van der Rohe, and many others. These house commissions rose to the level of monumental that makes them "Architecture" in the eyes of architects. In the latter case, the project seeks to improve how people live. An example of this type includes Frank Lloyd Wright's Broad Acre City. In general, however, architects have not been successful in obtaining a large share of the ordinary single-family house market.

In summary, the culture of architecture requires an architect to produce serious "Architecture" or risk not being taken seriously by his peers. Single-family house design in the U.S. has developed into a capitalist venture. Mass production leads to repeated designs with little creativity while also less expensive. An architect is trained to design a solution for a client on a specific site. Further, monumental aspirations are best achieved through public design commissions or designs for the wealthy. An architecture student goes through processes that teach him his own value and the value of his ideas. Long hours, all-nighters, isolation, and intense competition lead to a dedication for the cause of Architecture. The serious architect is not willing to reduce himself to doing anonymous designs for an uneducated public.

LIMITATION AND SCOPE

This paper addresses the rise of the single-family house up to World War II and outlines the role of the architecture profession in the design of these single-family houses in order to explain the current lack of participation by architects in the design of the majority of single-family houses in the U.S. today. This does not imply that architects do not design houses or housing; rather that the houses most people live in in North America are not designed by architects and how and why this came to be the case.

ACKNOWLEDGEMENTS

This document was adapted from my PhD dissertation written for the University of Missouri, PhD Architectural Studies, 2008, abstracted portions from chapter 2. Committee Chair, Benjamin Schwarz.

REFERENCES

- American Architect and Building News (AABN). 1880. "Architectural Education in England and Germany," *The American Architect and Building News* (April 24, 1880) Volume 7, 226.
- AABN. 1878. "Art School of Germany I," *The American Architect and Building News* (September 14, 1878) Vol. 4, 142.
- Boyer E. and Mitgang, L. 1996. *Building Community: A New Future for Architecture Education and Practice*. New Jersey: The Carnegie Foundation.
- Brown, J. 2007. "The Tailored Home—Creating an Alternative to the North American Cookie Cutter House," in *Thinking Inside the Box*, editors Ed Hollis, Alex Milton, Drew Plunkett, Andrew Milligan, Frazer Hay and John Gigli. London: Middlesex University Press.
- Cohen, J. 1994. "Building a Discipline: Early Institutional Settings for Architectural Education in Philadelphia, 1804-1890," *Journal of the Society of Architectural Historians*, Vol 53, No. 2 (June 1994): 139-183.
- Drexler, A. 1977. *The Architecture of the Ecoles Des Beaux-Arts*. Edited by Museum of Modern Art. New York: The MIT Press.
- Fisher, DK Este to Walter McCormack, November 17, 1938, American Institute of Architects Archives, AIA. Headquarters, Washington, D.C.
- Fowle, J. 2008. "Architect: Other titles are Remarkably More Flexible," *the Architects Journal* 39-41.
- Groat, L. 1993. "Architecture's Resistance to Diversity: A Matter of Theory as Much as Practice," *The Journal of Architectural Education*, 47, No. 1 (September 1993): 3-10.

Gutman, R. 1988. *Architectural Practice: A Critical View*. Princeton, N.J.: Princeton Architectural Press.

Gutman, R. 1987. "Educating Architects: Pedagogy and the Pendulum" in *The Public Face of Architecture: Civic Culture and Public Spaces* edited by Nathan Glazer and Mark Lilla. New York: The Free Press.

ICC. 2002. International Code Council, *International Building Code*. Country Club Hill, IL.

Mills, T. and Beliveau, Y. 2007. "US Production Homebuilding as a value added customer service through mass customization and design for manufacturing," XXXV World Congress of Housing Science.

Saint, A. 1993. *The Image of the Architect*. New Haven: Yale University Press

Upton, D. 1984. "Pattern Books and Professionalism: Aspects of the Transformation of Domestic Architecture in America, 1800-1860," *Winterthur Portfolio*, Vol. 19, No. 2/3.

Weatherhead, C. 1941. "The History of Collegiate Education in Architecture in the United States." Dissertation. New York: Columbia University.

Woods, M. 1999. *From Craft to Profession: The Practice of Architecture in Nineteenth Century America*. Berkeley, California: The University of California Press.

Wright, G. 1977. "Women in Architecture," in *The Architect*, Spiro Kostof, editor, , 2nd edition, 283.

ENDNOTES

- ¹ John Brown, "The Tailored Home—Creating an Alternative to the North American Cookie Cutter House," in *Thinking Inside the Box*, editors Ed Hollis, Alex Milton, Drew Plunkett, Andrew Milligan, Frazer Hay and John Gigli. London: Middlesex University Press, 2007.
- ² U.S. Census. 2014. Data retrieved from <http://www.census.gov/construction/C30/pdf/release.pdf> Document CB14-122 on 7/13/14.
- ³ Mary Woods, *From Craft to Profession: The Practice of Architecture in Nineteenth Century America*, (Berkeley, California: The University of California Press, 1999). Woods book presents this traditional view while Dell Upton challenges the clear cut distinctions in his work "Pattern Books and Professionalism."
- ⁴ Dell Upton, "Pattern Books and Professionalism: Aspects of the Transformation of Domestic Architecture in America, 1800-1860," *Winterthur Portfolio*, Vol. 19, No. 2/3.
- ⁵ Upton, "Pattern Books and Professionalism: Aspects of the Transformation of Domestic Architecture in America, 1800-1860," 113.
- ⁶ Woods, *From Craft to Profession: The Practice of Architecture in Nineteenth Century America*.
- ⁷ Woods, *From Craft to Profession: The Practice of Architecture in Nineteenth Century America*, 15.
- ⁸ *Ibid*, 15.
- ⁹ *Ibid*.
- ¹⁰ *Ibid*, 127.
- ¹¹ Dell Upton, "Pattern Books and Professionalism: Aspects of the Transformation of Domestic Architecture in America, 1800-1860," *Winterthur Portfolio*, Vol. 19, No. 2/3.
- ¹² *Ibid*.
- ¹³ *Ibid*, 114.
- ¹⁴ *Ibid*.
- ¹⁵ International Code Council, *International Building Code*, (Country Club Hill, IL 2002), 5.
- ¹⁶ DK Este Fisher to Walter McCornack, November 17, 1938, American Institute of Architects Archives, AIA Headquarters, Washington, D.C.
- ¹⁷ Thomas Mills and Yvan Beliveau, "US Production Homebuilding as a value added customer service through mass customization and design for manufacturing," XXXV World Congress of Housing Science, September 4-7, 2007.
- ¹⁸ Gwendolyn Wright, (1977) "Women in Architecture," in *The Architect*, Spiro Kostof, editor, , 2nd edition, 283.
- ¹⁹ Jeffrey Cohen, "Building a Discipline: Early Institutional Settings for Architectural Education in Philadelphia, 1804-1890," *Journal of the Society of Architectural Historians*, Vol 53, No. 2 (June 1994): 139-183.
- ²⁰ Drexler, Arthur, ed. *The Architecture of the Ecoles Des Beaux-Arts*. Edited by Museum of Modern Art(New York: The MIT Press, 1977).
- ²¹ *Ibid*.
- ²² *Ibid*
- ²³ *Ibid*
- ²⁴ *Ibid*
- ²⁵ *Ibid*.
- ²⁶ AABN, "Architectural Education in England and Germany," *The American Architect and Building News* (April 24, 1880) Volume 7, 226.
- ²⁷ *Ibid*.
- ²⁸ AABN. "Art School of Germany I," *The American Architect and Building News* (September 14, 1878) Vol. 4, 142.

-
- ²⁹ *The American Architect and Building News* (1876-1908): March 8, 1879, 74; APS Online.
- ³⁰ Jonathan Foyle, "Architect: Other titles are Remarkably More Flexible," *the Architects Journal* (2008) 39-41. This conflicts with Weatherhead who attributes the first program to the University of Liverpool in 1894.
- ³¹ *The American Architect and Building News*; April 24, 1880; 7, 226; APS Online
- ³² *The American Architect and Building News*; December 26, 1896, 1096; APS Online
- ³³ *The American Architect and Building News*; March 8, 1879, 74; APS Online.
- ³⁴ Clason Weatherhead. . "The History of Collegiate Education in Architecture in the United States." Dissertation (New York: Columbia University, 1941).
- ³⁵ Ibid.
- ³⁶ Ibid.
- ³⁷ One thing which Weatherhead does not address is the lack of text books in English for teaching architecture. Mary N. Woods PhD dissertation completed at Columbia University addresses how the *American Architect and Building News* periodical served this purpose until text books were developed.
- ³⁸ Weatherhead, 171-173.
- ³⁹ Ibid, 101.
- ⁴⁰ American Institute of Architects. "The Architect at Mid-Century: Evolution and Achievement." Volume 1, edited by Turpin C. Bannister (New York: Reinhold Publishing Corporation, 1954).
- ⁴¹ Ibid, 106-107.
- ⁴² Ibid.

Environmental measurements of classrooms at the Florida A and M University

Sang Bum Park¹, Ronald B. Lumpkin¹, Kathie Laurent¹, Khari Peart¹

¹Florida Agricultural and Mechanical University, Tallahassee, FL

ABSTRACT: Classroom environment was comprehensively investigated at Florida Agricultural and Mechanical University (FAMU) in Tallahassee, Florida. The purpose of this study was first to objectively measure environmental factors of classrooms at FAMU such as thermal conditions, indoor air quality, lighting and acoustics and to ascertain if the classroom environmental factors affect academic achievement of students in the college level. This study adds to a growing body of literature that the condition of school facilities affects student achievement at the elementary, middle, and high school levels.

A total of 11 classrooms in the Architecture building and the Education building at FAMU were measured twice to represent the empty classroom and the occupied classroom by students at two different locations in each classroom. The classroom environments at the occupied condition were measured while lectures were ongoing during 2014 fall. Thermal conditions such as dry-bulb temperature, wet-bulb temperature and % relative humidity were measured to investigate thermal comfort. CO₂ concentration was measured to evaluate the indoor air quality. Light levels were measured in accordance to the style of the lectures. The background noises were measured and compared with NC curves. Room acoustical parameters such as Sound Transmission Index (Speech Intelligibility), Reverberation Time, D50, etc. were not measured at this time.

The classrooms with recent renovation showed relatively better classroom environment in all environmental factors. The background noise levels of the classrooms in the Architecture building were higher than 55dBC, whereas those in the Education building were maintained below it. The light level requirement of 430 lux established by Florida Department of Education seems not effective for the classrooms in universities where various classroom activities occur. The CO₂ concentration levels were not stable but dependent on the outdoor temperature while the temperatures were maintained in the classrooms.

KEYWORDS: Classroom Environment, CO₂ Concentration, Temperature, Lighting, Acoustics

INTRODUCTION

The quality of the school buildings forms the framework for teaching and learning, so that environmental factors such as temperature, indoor air quality, lighting and acoustical control influence student behavior and academic achievement (Edwards 2006, Lumpkin 2013). Proper temperature, indoor air quality, lighting and acoustics have been shown to improve the quality of the learning environments in schools and may lead to higher student achievement (Schneider, 2002). Inadequate indoor air quality in schools is linked to higher health care costs, increased absenteeism, and lower test scores. At the elementary, secondary, and high school level, the condition of classrooms is more correlated to student performance than the combined influences of family background, socioeconomic status, school attendance, and behavior (Lyons 2001).

High student achievement, retention, and graduation rates are the primary goal of educators and a multi-cultural global economy benefits from its attainment. College and university classrooms provide the physical spaces where teaching and learning occur that help fulfill this goal. Park and Choi (2014) stated "the classroom is one of the crucial physical services that a university provides to support students' learning" (p. 756). Most of the literature investigating the relationship between the condition of classrooms and student academic achievement exist at the elementary, secondary, or high school level. Limited research has examined the impact of classroom environmental conditions on student academic achievement at the college or university level.

The purpose of this study was first to investigate classroom environments measuring environmental factors and secondly to ascertain if the environmental factors influence the academic achievement as measured by performance on exams. Students' academic performance would be compared in college classrooms at Florida A&M University (FAMU) after the final grade is posted. In this paper, the objective environmental measurements would be performed and addressed.

1.0 BACKGROUND LITERATURE: IMPORTANCE OF CLASSROOM ENVIRONMENT

There has been scientific research investigating adverse effects of indoor environments on human health. The environments would be thermal environment, indoor air quality, visual environment, acoustic environment, etc. Many researchers also have been studying the relationship between the indoor environments and the health and the performance of people. Researchers determined the Sick Building Syndrome (SBS) and Building Related Illness (BRI) which were associated with poor indoor air quality of commercials and institutional buildings in the 1970s (Kreiss 1989). When it comes to indoor air quality, higher indoor CO₂ concentrations indicating less outdoor air ventilation were associated with students' lower scores on a computerized test of reaction time (Myhrvold et al. 1996). There were research that have demonstrated a quantitative relationship between work performance in office environments and ventilation (Seppänen et al. 2006; Shaughnessy et al. 2006; Bear 1993). Earthman pointed out that increases in temperatures in the workplace tends to decrease workers efficiency and increases the risk of work related accidents (Earthman 2002). As a result, proper control of the thermal environment is needed in the workplace. Daylighting plays an important part in the indoor environmental quality and has a positive effect on an occupant's perception of productivity and performance (Heschong et al. 1999). Researchers have been studying the negative effects of ambient noise and poor room acoustics on students' performance such as memory, educational progress, reading scores, etc. (Bradley and Sato 2008; Crandell et al. 1995; Evans and Maxwell 1997).

1.1. Thermal condition

Good thermal environment of a classroom is very important to be achieved for students' academic achievement. Many researchers have studied thermal conditions in the business and industrial workplace and the overall conclusion of these research was that increases in temperatures in the workplace tend to decrease workers efficiency and increase the risk of work related accidents (Earthman 2002; Uline 2006). These studies have provided some of the motivation for research efforts on the influence the thermal quality of the classroom has upon students. As a result, proper control of the thermal environment is necessary for students' academic satisfaction.

In addition, researchers have been studying the temperature range associated with better learning for several decades. Harner found that the best temperature range for learning, reading and math is 20°C (68°F) to 29°C (84°F) and that the ability to learn these subjects is adversely affected by temperature above 23°C (74°F) (Harner 1974). As temperature and humidity increase, students report greater discomfort, and their achievement and task-performance deteriorate as attention spans decrease. Furthermore, there is a general thermal comfort suggested by ASHRAE Standard 55-2013. It considers amount of clothing during summer and winter aside from dry-bulb temperature and quantity of moisture in air, although it does not take radiant heat energy into account. In sum, in order to determine thermal comfort of classroom environment, dry-bulb temperature, wet-bulb temperature and relative humidity would be measured (Harner 1974; Mendell and Heath 2005).

1.2. Indoor air quality

Recent independent studies have documented that the quality of indoor air has a significant and positive influence on the productivity of office workers (Clements-Croome et al. 2008; Kajtár et al. 2006; Myhrvold et al. 1996) and that there is a linear relationship between ventilation rate and test scores for the range of schools with ventilation rates below the recommended minimum. Some of the research showed some evidence that can link low ventilation rates with reduced attendance (Shendell et al. 2004) and with the students' school work performance (Wargocki et al. 2005). Mendell and Heath¹⁸ also reviewed evidence that certain conditions commonly found in US schools have adverse effects on the health and the academic performance of many of the more than 50 million US school children (Mendell and Heath 2005). One of the first symptoms of poor ventilation in a building is a buildup of CO₂ caused by human respiration. When CO₂ levels reach 1000 parts per million (ppm) which is about three times what is normally found in the atmosphere, headaches, drowsiness, and the inability to concentrate can occur. Myhrvold et al. found that increased CO₂ levels in classrooms owing to poor ventilation decreased student performance on concentration tests and increased students' complaints of health problems as compared to classes with lower CO₂ levels (Myhrvold et al. 1996). Thus, the CO₂ concentrations can be translated into ventilation rates assuming a source term for CO₂ generation, and assuming CO₂ concentration had reached steady state in the room based on ASTM D 6245, and will be measured.

1.3. Lighting

Lighting and daylighting play an important role in the indoor environmental quality and have a positive effect on an occupant's perception of productivity and performance (Heschong et al. 1999; Xue 2002). Classroom lighting plays a particularly critical role in student performance (Philips 1997). Video projectors and smart boards are actively used in a large portion of the classes in universities these days. The variation of illuminance with and without the use of projectors would provide different visual environment and it would be worthy to measure the lighting level variation during the lecture.

1.4. Acoustics

Acoustics have been shown to have an impact on student learning. There are many consistent and convincing evidence that acoustics links to learning (Cash 1993; Earthman 2004; Hines 1996). In general, good acoustics are fundamental to good academic performance. Earthman and Lemasters reported three key findings that higher student achievement is associated with schools that have less external noise, that outside noise causes increased student dissatisfaction with their classrooms, and that excessive noise causes stress in students (Earthman and Lemasters 1998). Crandell et al. and Nabelek and Nabelek reviewed the literature linking the acoustical environment in a classroom to the academic achievement of children and have linked levels of classroom noise and reverberation to reading and spelling ability, behavior, attention, concentration, and academic achievement in children (Crandell et al. 1995; Nabelek and Nabelek 1994). Evans and Maxwell examined 100 students enrolled in two New York City schools, one of which was in the flight path of an airport. The students exposed to the air-traffic noise scored as much as twenty percent lower on a reading test than children in the other school (Evans and Maxwell 1997).

2.0 RESEARCH GOALS AND OBJECTIVES

2.1. Research goals

The primary goal of the research is to contribute to creating a learning environment for students at the FAMU by investigating the physical and architectural properties associated with better classroom environments such as thermal conditions, indoor air quality, lighting and acoustics. This will eventually lead to efficient students performance. In this research, the physical and architectural properties of the classroom would only be investigated over classrooms at the FAMU, although students' social dynamics, learning climate, teachers behavior and attitudes, etc. would be all the possible factors associated with student's performance as well.

The long term goal is to develop architectural design guideline for university classrooms. In the sense that video projection and sound systems are actively used in the university classroom, different design guidelines from K - 12 public schools would be required especially for visual and acoustic comfort during the classes. The design guideline should reflect the possible findings related to the environmental and architectural features of the classroom environments.

2.2. Research objectives

In order to achieve the long term goals, there would be three research objectives in this research. First, environmental factors of the classrooms such as thermal conditions, indoor air quality, lighting and acoustics would be measured by objective means. Classroom environments would be a measure of the cumulative effects of them. Many researches, however, provided not enough objective data to evaluate the classroom environment. Instead, they rather used questionnaires to determine the physical qualities of the classrooms rated by the occupants. In this research, the physical properties of the classroom environments would be objectively measured to determine each environment and the comprehensive conditions of the classrooms.

Second, statistical approach would be used to test the possible effects of classroom environments on students performance. The objective measurement data of the classrooms would be compared with the grades of the students by various statistical methods such as factor analysis, liner regression, paired t-test, etc., in order to find important environmental factors that impact students' academic performance.

Lastly, to validate the effects of classroom environments on students performance, some of the classrooms measured would be sampled and treated for improvement of the environmental factors. This validation may be performed during the 2015 summer or fall after the improvement of the classroom.

In this paper, only the objective environmental measurements of classrooms at the FAMU would be performed and addressed.

3.0 METHODOLOGY

3.1. Objective environmental measurement

The environmental qualities of classrooms at the FAMU were measured by objective means. The TSI-7545 indoor air quality meter was used to measure thermal properties such as dry-bulb temperature (°C), wet-bulb temperature (°C) and relative humidity (%) and carbon dioxide concentration (CO₂) as a means for indoor air quality. The outdoor CO₂ level was not measured but assumed that it is approximately 300 ppm. This would limit the indoor CO₂ level in 1000 ppm, because the indoor level should not be 700 ppm greater than the outdoor level according to ASHRAE 62.1-2013. Light levels (lux) were measured by the Extech LT-300 light meter. Background noise levels (dBC) were measured by the Rion NL-52 Class 1 sound level meter and compared with Noise Criterion (NC) curves. Two sets of environmental measurements were conducted at

two separate locations in each room. One set of measurement was to measure the environmental factors of the empty classrooms and the other was to measure when the classrooms were occupied by students. A total of 11 classrooms including 4 classrooms in the Walter Smith Architecture building (henceforth Architecture building) and 7 classrooms in the Gore Education Complex building (henceforth Education building) were measured.

The classrooms were measured at least twice to represent the classroom environment without students and with students. Thermal conditions such as dry-bulb temperature, wet-bulb temperature and % relative humidity were measured to investigate thermal comfort in each room. CO₂ concentration was measured to evaluate the indoor air quality as a replacement of ventilation rate. Light levels were measured on the desk level with all the lights turned on for the empty condition and in accordance to the lectures for the occupied condition. The background noises were measured in the 1.2 m above the floor and compared with NC curves. The sound pressure levels were measured to see the general sound pressure levels during the lecture. Room acoustical parameters such as Sound Transmission Index (Speech Intelligibility), Reverberation Time, D50, etc. were not measured at this time.

3.2. Architecture building

The Architecture building has only four classrooms while there are many open design studios and office rooms. The four classrooms, ARC111, ARC112, ARC 121 and ARC233, are all different in size to accommodate a various style of lectures from small size lecture to large size seminar and daylight is not available at all classrooms. Although ARC233 has a glass wall, the top lighting in the north atrium of the building is blocked by the parapet on the third floor and then enters the room in low light level. The room temperature is monitored at the thermostat located in the room and controlled by only the central plant personnel. There are multiple supply air diffusers while there is no specific return grilles in the classrooms. The regulated air is returning through hallways and the air plenum above each room. There are a video projector, a projection screen, a sound system, video players, etc. in each room (see Table 1).

Table 1: Floor plans of the four classrooms in the Architecture building showing floor areas, room volumes, and classroom environmental measurement locations under empty condition.

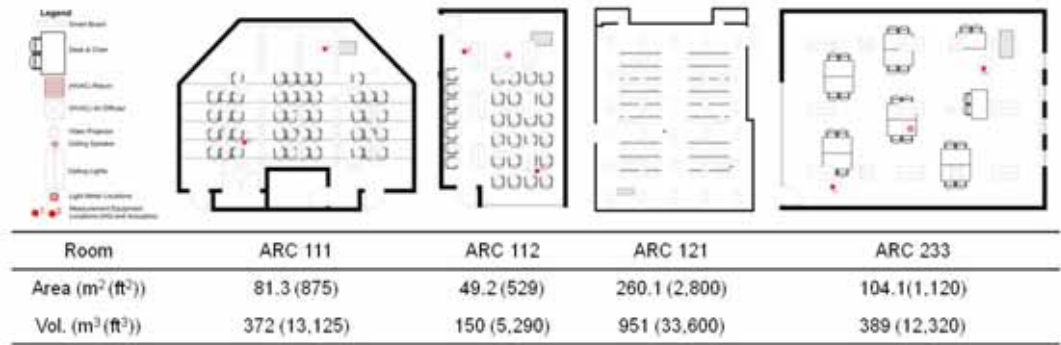

The occupied condition of the classroom, ARC 112, was not measured, because all classes in ARC 112 has been moved to dean's conference room in the Architecture building due to technology update in 2014 fall semester.

3.3. Education building

The Education building consists of three wings. The classrooms on the first floors of the A and B wings are used as classrooms. The classrooms were renovated 4 years ago. The classrooms sampled were those that the instructors permitted the environmental measurements during the lecture. A total of 7 instructors were approved to the research. Their lectures were held in the GEC A107, A108, A110, A112, B101, B103, and B104. The environmental measurements were performed when there was no class in the Education building as empty conditions.

The classrooms in the Education building are similar in size, color, finishes, furniture, etc. There are 3 or 4 supply air diffusers and 2 return grilles each classroom. The dry-bulb temperature is monitored by a thermostat on the side wall and maintained by the central plant personnel. Each room has 2 (0.6m x 2.7m) glasses on the exterior walls which provide daylight. The windows, however, were not operable and not delivering adequate light level because of the small size and inefficient locations which could not reach the other side of the room (see Table 2). The electric lighting fixtures (0.6m x 1.2m) were well distributed over the classrooms and has three separate switches providing 6 different lighting modes and light levels on the desk to accommodate various types of lectures.

Only 5 classes of them, however, were observed and measured during the lecture due to the unexpected circumstances, which resulted in a total of 5 classrooms (GEC A108, A112, B101, B103 and B104) could be measured with students occupied.

Table 2: Floor plans of the four types of classrooms in the Education building showing floor areas, room volumes, glazing and classroom environmental measurement locations under empty condition.

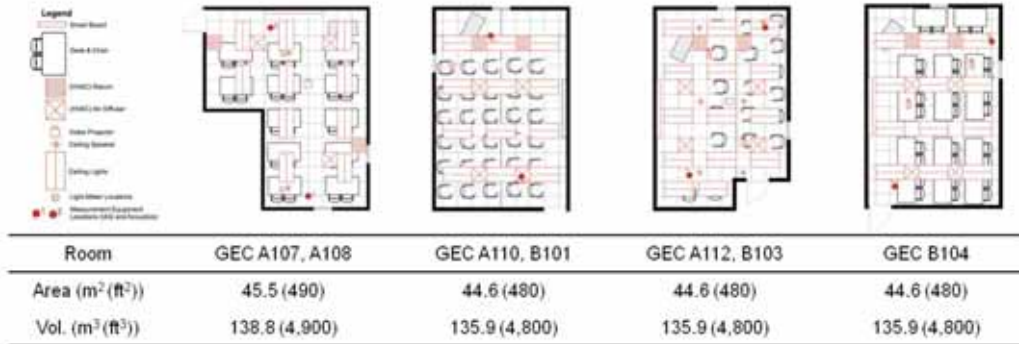

4.0. RESULTS AND DISCUSSIONS

4.1. Empty conditions

A total of 11 classrooms were measured when there is no students other than experimenters during the weekdays. The averaged thermal conditions were well maintained within the thermal comfort zone specified by ASHARE Standard 55-2013 (see Table 3). Light levels with all the electric lighting fixtures on, on the other hand, ranged from 204.4 lux to 397.2 lux in the classrooms in the Architecture building, while all the classrooms in the Education building showed light levels above the State Requirement for Education Facilities established by Florida Department of Education which is 430 lux (40 fc). The background noise levels of classrooms are limited to be less than 55 dBC (ANSI/ASA S12.60-2010/Part 1) and the recommended NC values are NC-30 to NC-35. The classrooms at the Architecture building showed higher background noise levels than the both recommendation, whereas those in the Education building showed lower background noise levels (see Fig. 1).

Table 3: The averaged thermal conditions (dry-bulb temperature (DBT), wet-bulb temperature (WBT) and relative humidity (%)), CO₂ concentration (ppm), light levels, Noise Criteria (NC) and overall background noise levels of the 11 classrooms when there is no students in the classrooms.

Classroom	DBT (°C)	WBT (°C)	% RH	CO ₂ (ppm)	Light level (lux)	NC	Overall (dBC)
ARC 111	24.9	16.4	42.0	1076	203.4	39	72.5
ARC 112	24.9	16.4	41.9	1020	-	39	63.9
ARC 121	22.4	16.2	52.2	583	375.7	36	60.6
ARC 233	22.3	15.4	48.5	627	397.2	31	62.7
GECA 107	25.6	11.2	21.5	517	428.4	27	48.9
GECA 108	22.3	11.6	24.4	537	599.5	33	51.5
GECA 110	23.0	11.6	22.1	500	784.7	32	53.9
GECA 112	22.8	11.6	22.8	509	447.8	32	51.3
GECB 101	23.1	15.5	44.7	609	578.0	27	49.7
GECB 103	21.3	10.4	21.8	477	532.8	27	53.2
GECB 104	21.0	10.6	24.0	503	742.7	27	52.0

4.2. Occupied conditions

A total of 9 classrooms (ARC111, ARC121, ARC233, GEC A108, A112, B101, B103, and B104) were measured under occupied condition when actual lectures were on going. The thermal conditions were not significantly different from when the classrooms were empty. However, there was a tendency that the dry-bulb temperature and wet-bulb temperature increased while relative humidity decreased over time with students occupied. Although the difference of thermal conditions between the times when the lecture began

and ended was not significant, the CO₂ concentration levels significantly increased over the class time period with students occupied in the classroom (see Fig.2 and Table 4). The delta 'Δ' indicates the differences of each factor between the times when the lecture began and ended.

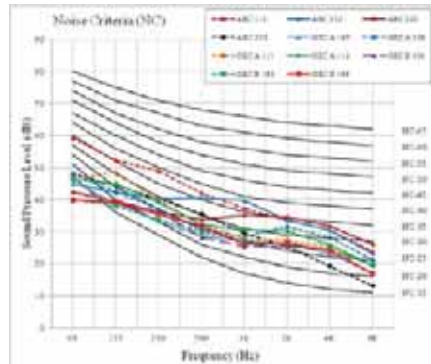

Figure 1: Background noise levels of the 11 classrooms and the noise criteria contours: noise criterion of a background noise level is defined by the noise criteria contours.

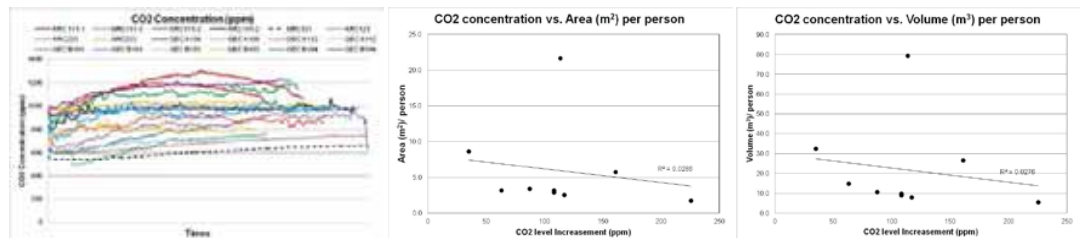

Figure 2: CO₂ concentration levels in the 7 classrooms when the lectures were ongoing (left). The CO₂ concentration levels were measured at two different locations. CO₂ concentration increase was also compared with floor area (m²) per person (middle) and with room volume (m³) / person (right).

In order to scrutinize the effects of students' perspiration, the CO₂ concentration levels were also compared with two values: floor area (m²) per person and room volume (m³) per person. The number of students in this case was not the number of seats but the number of students who attended the lecture during the environmental measurement. The reason that there is one peak in the right chart (Fig.2) is that the room, ARC 121, is relatively bigger than other classrooms measured, but there were only 12 students presented at that time. There was a tendency that CO₂ concentration level did not increase much in the classrooms that have larger room volumes per person than those with less room volumes per person (see Table 4).

Table 4: The averaged thermal conditions (dry-bulb temperature (DBT), wet-bulb temperature (WBT) and relative humidity (%)), CO₂ concentration (ppm), light levels, Noise Criteria (NC) and overall background noise levels of the 7 classrooms when they were occupied by students. The ARC 111 measured twice for two different classes in two different times. The delta 'Δ' indicates the differences of each factor between the time when the lecture began and the time when it ended.

Classroom	DBT (°C)	WBT (°C)	RH (%)	CO ₂ (ppm)	Δ DBT (°C)	Δ WBT (°C)	RH (%)	Δ CO ₂ (ppm)	Floor Area (m ²)	Vol. (m ³)	N. of Student	m ² /per.	m ³ /per.
ARC 111-1	22.2	14.2	40.3	683	0.1	2.8	-2.7	161	81.3	372	14	5.8	26.6
ARC 111-2	22.1	16.0	53.9	1140	0.0	-1.9	-0.1	63	81.3	372	25	3.3	14.9
ARC 121	23.2	16.3	48.9	642	0.9	0.3	-2.7	113.5	260.1	951	12	21.7	79.3
ARC 233	23.1	16.3	49.7	988	0.0	-0.1	-0.6	35	104.1	389	12	8.7	32.4
GECA 108	22.8	15.9	48.8	970	0.9	0.3	-2.3	108	45.5	136	14	3.3	9.7
GECA 112	22.4	15.8	50.2	914	-0.1	-0.1	-0.1	87.5	44.6	139	13	3.4	10.7
GECB 101	23.3	17.3	55.2	885	-0.1	0.4	3.3	108	44.6	136	15	3.0	9.1
GECB 103	21.8	14.2	42.6	740	1.3	0.6	-2.5	117	44.6	136	17	2.6	8.0
GECB 104	24.2	16.6	46.6	1120	2.8	0.6	-10.6	225.5	44.6	136	25	1.8	5.4

In addition, it was observed that the CO₂ concentration level of ARC 111 showed 457 ppm difference between two measurements. The measurement, ARC 111-1, was measured at 9am in November 4, 2014 and the ARC 111-2 was measured at 11am in November 6, 2014. Interestingly enough, the CO₂ concentration in the ARC 233 measured at 5:30pm in November 6 were also showed 361 ppm higher than that conducted in October 30, 2014. In this sense, it is worthy to look at the CO₂ concentration levels of all classrooms by dates (see Table 5) to see if there were specific dates with high CO₂ concentration overall.

As shown the table, the four dates (10/30, 11/6, 11/12, and 11/13 in 2014) showed high CO₂ concentration levels. Based on the weather data, outdoor daily average dry-bulb temperature was suddenly dropped from 21.1 °C (70 °F) in October 27, 2014 to 8.9 °C (48 °F) in November 2, 2014. This might change the setting of air handling units in the buildings to heating the supply air, which in turn might change the portion of fresh air in the air handling units. Therefore, it is possible to say that the CO₂ concentration is somehow associated with the way that an air handling unit regulates the amount of fresh air and return air based on the exterior dry-bulb temperature.

Table 5: CO₂ concentration levels of all 11 classrooms by measurement dates. Shaded areas are showing higher CO₂ levels.

Classroom	10/9	10/13	10/30	11/4	11/6	11/10	11/12	11/13	11/14	11/17	12/3
ARC 111	-	554	1076	683	1140	-	-	-	-	-	-
ARC 112	-	575	1020	-	-	-	-	-	-	-	-
ARC 121	698	-	-	-	-	-	-	642	-	-	-
ARC 233	-	-	627	-	988	-	-	-	-	-	-
GECA 107	-	-	-	-	-	-	-	-	517	-	-
GECA 108	-	-	-	-	-	-	-	970	537	-	-
GECA 110	-	-	-	-	-	-	-	-	500	-	-
GECA 112	-	-	-	-	-	-	914	-	509	-	-
GECB 101	-	-	-	-	-	-	-	-	609	885	-
GECB 103	-	-	-	-	-	740	-	-	-	-	477
GECB 104	-	-	-	-	-	-	-	1120	503	-	-

The light levels of classrooms measured were varied because of the various style of lectures in the classrooms, although the electric lighting fixtures were evenly distributed across the rooms. There were lighting switches in each classroom to control the electric lighting fixtures creating three to four different levels of lighting depending on the lecture style. The lighting level in the middle of the room GEC B101 was measured at 781.5 lux (73.6 fc) right under the electric lighting fixture with daylight and all the lighting fixtures on, but it was measured at 33.4 lux (3.1 fc) with all the lights off. The lighting level was set at 578 lux (53.7 fc) during the class when the students used the smart board and handout materials for their presentations but the quality of the video projection on the smart board was not clear enough at that time, because the light level of the room was too bright for the images projected on the smart board. The classroom, ARC 121, on the other hand, has no daylight. The light level of the classroom was measured 29 lux (2.7 fc) with the emergency lighting fixtures. It was set at 338 lux (31.4 fc) for the presentation and 363.8 lux (33.8 fc) with all the lights on.

CONCLUSION

A total of 11 classrooms in the Architecture building and the Education building at the Florida A and M University were measured in regards to classroom environmental factors such as thermal conditions, CO₂ concentration, lighting levels, and background noise levels. The classrooms with recent renovation (the Education building) showed relatively better classroom environment in all environmental factors. Especially, the background noise levels of the classrooms in the Architecture building were higher than 55dBC which is recommended by ANSI/ASA S12.60-2010/Part 1, whereas those in the Education building were maintained below it. The light level requirement (430 lux (40 fc)) established by Florida Department of Education, on the other hand, seems not effective to be adapted to the classrooms in universities. The activities of the classrooms at FAMU varied from writing to presentation which would require different light levels as well as good quality of video projection. The CO₂ concentration levels increased by students' perspiration during the class period. The CO₂ concentration levels were not stable but significantly changed even in the same classroom (ARC 111) at different times and dates. This would be possibly because of the air handling unit that mixes return air and Oxygen rich fresh air differently under various weather condition while it maintains relatively stable dry-bulb temperature in the classrooms. Therefore, apart from dry-bulb temperature, it would be necessary to monitor CO₂ concentration to provide students with better indoor air quality resulting in better academic achievement.

FUTURE STUDY

As a following study, the environmental measurement data will be statistically analyzed and compared with the final grades of the students who have studied in the classroom measured. More detail analyses of light level and acoustics are required to study adequate levels of lighting and speech intelligibility for various class activities.

REFERENCES

- Bearg, D. W., 1993. *Indoor air quality and HVAC systems*. CRC Press.
- Bradley, J. S., & Sato, H., 2008. *The intelligibility of speech in elementary school classrooms*. The Journal of the Acoustical Society of America, 123(4), 2078-2086.
- Cash, C. S., 1993. *Building condition and student achievement and behavior* (Doctoral dissertation, Virginia Polytechnic Institute and State University).
- Clements-Croome, D. J., Awbi, H. B., Bakó-Biró, Z., Kochhar, N., & Williams, M., 2008. *Ventilation rates in schools*. Building and Environment, 43(3), 362-367.
- Crandell, C. C., Smaldino, J. J., & Flexer, C., 1995. *Sound-Field FM Amplification: Theory and Practical Applications*. Thomson Learning, Customer Service, 10650 Toeppen Drive, Independence, KY 41051.
- Earthman, G. I., & Lemasters, L., 1998. *Where Children Learn: A Discussion of How a Facility Affects Learning*. paper presented at the Annual Meeting of Virginia Educational Facility Planners, Blacksburg, VA, February.
- Earthman, G. I., 2002. *School facility conditions and student academic achievement*. UCLA's Institute for Democracy, Education, & Access.
- Earthman, G. I., 2004. *Prioritization of 31 criteria for school building adequacy: American Civil Liberties Union Foundation of Maryland*. Accessed online on, 10, 04-08.
- Edwards, B. W., 2006. *Environmental design and educational performance with particular reference to "green" schools in Hampshire and Essex*. Research in Education, 76, 14-21, 23, 25-32.
- Evans, G. W., & Maxwell, L., 1997. *Chronic Noise Exposure and Reading Deficits The Mediating Effects of Language Acquisition*. Environment and Behavior, 29(5), 638-656.
- Harner, D. P., 1974. *Effects of thermal environment on learning skills*. The Educational Facility Planner 12 (2): 4-6.
- Heschong, L., Mahone, D., Kuttaiah, K., Stone, N., Chappell, C., & McHugh, J., (1999). *Daylighting in schools: An investigation into the relationship between daylighting and human performance*. Summary for the Pacific Gas and Electric Company on behalf of the California Board for Energy Efficiency Third Party Program.
- Hines, E. W., (1996). *Building condition and student achievement and behavior*, (Doctoral dissertation, Virginia Polytechnic Institute and State University).
- Kajtár, L., Herczeg, L., Lang, E., Hrustinszky, T., & Banhidi, L., 2006. *Influence of carbon-dioxide pollutant on human well-being and work intensity*. In Proc Healthy Buildings Conf (Vol. 6, No. 1, pp. 85-90)
- Kreiss, K., 1989. *The epidemiology of building-related complaints and illness*, Occup. Med., 4, 575-592.
- Lumpkin, R., 2013. *School Facility and Socioeconomic Status: Impact on Student Achievement*, (Doctoral Dissertation, Florida A&M University).
- Lyons, J., B., 2001. *Do School Facilities Really Impact a Child's Education?* Washington, DC: National Clearinghouse for Educational Statistics. Retrieved from www.sdpl.coe.uga.edu/articlesandpapers
- Mendell, M. J., & Heath, G. A., 2005. *Do indoor pollutants and thermal conditions in schools influence student performance? A critical review of the literature*. Indoor air, 15(1), 27-52.
- Myhrvold, A.N., Olsen, E. and Lauridsen, O., 1996. *Indoor environment in schools - pupils health and performance in regard to CO2 concentrations*. Indoor Air '96: Proceedings of the 7th International Conference on Indoor Air Quality and Climate, Vol. 4., 396-374.
- Nabelek, A., & Nabelek, I., 1994. *Room acoustics and speech perception*. Handbook of clinical audiology, 624-637.
- Park, E. L., & Choi, B. K., 2014. *Transformation of classroom spaces: Traditional versus active learning classroom in colleges*. Higher Education, 68(5), 749-771. doi:<http://dx.doi.org/10.1007/s10734-014-9742-0>
- Philips, R., 1997. *Educational facility age and the academic achievement of upper elementary school students*. D. Ed. diss., University of Georgia.
- Schneider, M., 2002. *Do school facilities affect academic outcome?* National Clearinghouse for Educational Facilities, 1-24. Retrieved from <http://www.eric.com>.
- Seppänen, O., Fisk, W.J. and Lei, Q.H., 2006. *Ventilation and performance in office work*, Indoor Air, 16, 28-36.
- Shendell, D. G., Prill, R., Fisk, W. J., Apte, M. G., Blake, D., & Faulkner, D., 2004. *Associations between classroom CO2 concentrations and student attendance in Washington and Idaho*. Indoor air, 14(5), 333-341.
- Shaughnessy, R. J., Haverinen-Shaughnessy, U., Nevalainen, A., & Moschandreas, D., 2006. *A preliminary study on the association between ventilation rates in classrooms and student performance*. Indoor air, 16(6), 465-468.
- Standard, A. S. T. M., 1998. ASTM D 6245. *Standard Guide for Using Indoor Carbon Dioxide Concentrations to Evaluate IAQ and Ventilation*.
- Uline, C. Tschannen-Moran., 2006. *The wall speaks: the interplay of quality facilities, school climate, and student achievements*. Journal of Education Administration, 46(1), 55-73.

A parametric metamorphosis of Islamic geometric patterns: The extraction of new from traditional

Mostafa Alani¹, Carlos Barrios¹

¹Clemson University, Clemson, SC

ABSTRACT: A method for the exploration of design space in traditional Islamic geometrical patterns is presented. The method uses traditional Islamic geometry as a starting point and performs a metamorphosis operation for geometrical creation and exploration of possible variations.

KEYWORDS: Parametric Design, Metamorphosis, Patterns Generation, Islamic Geometric Pattern

INTRODUCTION

A considerable amount of research has been conducted to answer the question of how to create both traditional and new Islamic geometrical patterns. Researchers have attempted to answer this question manually and digitally. Some scholars focus on how to simulate traditional patterns, while others aim to create new patterns from scratch. These studies enrich the literature by simulating the methods used by the original artists, architects, and craftsman; by presenting new design methods; and by improving existing methods. This study takes a new approach toward answering the initial question. Our work focuses on how to extract new patterns out of existing ones.

According to Syed Abas and Amer Salman (Abas et al. 1995) Islamic geometric patterns are defined as patterns that contain:

1. Arabic calligraphy
2. Where created between 900 AD and 1500 AD by Muslims or non-Muslims in a society where the common practiced religion was Islam
3. Patterns derived from Arabic calligraphy or traditional patterns

In this paper, we build upon this third definition to explore Islamic geometric patterns by deriving them from existing geometries.

By starting with decomposing and parameterization existing traditional Islamic geometry, we can derive new, unique geometries from them. In other words, this research tries to move beyond the creation of the geometry to the exploration of the geometry. In that sense, this method can be used to conduct an analytical study of the geometric patterns to improve the understanding of the formal qualities of the geometric pattern. For instance, by exploring all possible combinations of the geometric components within a pattern, it will be possible to identify the desirable systems of proportion.

Because large number of geometrical derivations can be reached, which makes counting designs relatively impossible; this paper will express the geometric metamorphoses that provide a convenient way to explore possibilities. By adding the fourth dimension of time to the process, it becomes possible for the designer to express the keyshape of the geometry, i.e., the state of the geometry at a particular point in time (Kolarevic 2004). The question that needs to be asked at this point is it possible for a keyshape of one geometry to be qualitatively and quantitatively equal to an existed Islamic geometry?

We have built a computer representation model to construct the entities of the geometrical patterns with modifiable attributes. This is known as a parametric model, and it allows us to explore all design variations with ease (Barrios Hernandez 2006). By defining certain rules that govern the parameter values, the designer can explore the patterns in a manual or metamorphic manner. The variation performed on the fundamental unit level, which is a specifically defined portion of the repeat unit, will populate the level to the repeat unit using symmetry and either translation, rotation, or a combination of the two. Thus, the parameterization of the fundamental unit will allow designers to manipulate the whole pattern.

1.0 PRECEDENCE

Scholars have done magnificent work on how to define the fundamental unit and populate it on the geometry. Hareesh Lalvani presents a method of coding that generates classes of various patterns from different cultures (Lalvani 1989). His method involves defining the fundamental unit and using symmetry to populate the resulted geometries of the pattern.

Ahmad Aljamali takes an approach similar to Lalvani's, defining a fundamental unit to control the shape of the pattern by the radius of the repeated unit and the angle of rotation (Aljamali and Banissi 2003). Craig Kaplan creates a program that allows him to explore the design space of Islamic stars by manipulating the sub-motifs (Kaplan and Salesin 2004). Ali Izadi creates a code that explores different geometries by controlling of the main points in the motif (Izadi, Rezaei, and Bastanfard 2010).

Most of them have worked to provide a method for simulating traditional patterns and for exploring new patterns made from scratch. The method we are proposing does not simulate traditional geometries, neither does it generate new geometry from scratch. Rather, it performs post-design analysis of an existing geometry to produce new, unique design patterns.

2.0 THE PROPOSED METHOD

The proposed method works on existing geometry. It does not create new geometries from scratch but rather performs spatial transformations on the provided Islamic geometry based on specific rules. But before presenting the proposed exploration method, it is necessary to introduce two approaches to geometrical exploration of Islamic geometric patterns. The first approach enables the exploration without preserving the qualitative properties of the geometry (i.e. performing topological transformation), and the other preserves the geometry's qualitative properties (i.e., the produced geometry will have the same number of points, lines, and faces) (Kolarevic 2004).

Both approaches share the method of finding of the fundamental unit and building the parametric model, i.e., defining the fixed and modifiable attributes; however, different rules govern their special transformations.

2.1. The fundamental unit

The method acts on the repeated unit level and then populates the results globally to the pattern. Both Issam El-Said (El-Said et al. 1993) and Rima Al Ajlouni (Al Ajlouni 2012) have clearly distinguished between the repeat unit (the seed), which is the basic geometrical composition, and the pattern (structure), which is the product of systematically repeating the geometry.

To find the fundamental unit, the repeat unit is decomposed to its constructional components. This operation will produce a fundamental unit, which is defined as the minimum motif that cannot be reached with symmetry.

To make the process of finding the fundamental unit easier, we first need to determine the cell unit. According to Abas and Salman (Abas et al. 1995), the cell unit is the region with the minimum motif that may be repeated to create the whole geometry. In this paper we differentiate between the cell unit and the fundamental unit. Because the method we are defining does need a completed geometry to begin, it is always a good idea to break down the steps of finding the fundamental unit by analyzing the type of the geometry.

Cell units can be created by dividing the polygon that contains the repeat unit into triangles. The first point of each triangle is located at the center of the polygon, and the other two points are located at the constructional points of one of the sides (Figure 1). Cell units can hold more than one of a fundamental unit, a whole fundamental unit, or less than one of a fundamental unit. There are no specific rules that govern the relationship between the fundamental unit and the cell unit; in fact, it depends on who originally designed the geometry. Aljamali (Aljamali and Banissi 2004) proved that point by breaking up the steps of creating Islamic geometric patterns into four stages: the planer surface stage, the divisional stage, the artistic stage, and the extension stage. The artistic stage is an important factor to consider in determining the fundamental unit. The combined cell units that contains the fundamental unit are defined as the fundamental region.

2.2. Fundamental unit parameterization

In this step, a point should be assigned at each segment intersection in the fundamental unit. An intersection can occur between one segment and another or between the intersection of a segment and the boundaries of the fundamental region.

Having constructed the points, the next step is to build the parametric model. This step involves deconstructing each defined point from the previous step into x and y coordinates and then adding or subtracting a number from the coordinates to relocate a point with the new coordinates. The line segments should correspond to the changes that occur in the point, thus creating a new geometry.

2.3. Rules of spatial transformation

In general, points can be categorized into: (1) constrained points, or points that can travel toward and against the center of the polygon; (2) linked constrained points, which occur when two constrained points are symmetrical and located on the sides of the fundamental region, those two points must always be moving in accordance with each other by taking the same value of change; and (3) anchored points, or points that cannot move at all cases (moving an anchored point can break the continuity of the pattern as well as create additional intersections). All the points located on the outer edge of the repeated polygon are considered anchored points, and the rest are either constrained or linked constrained.

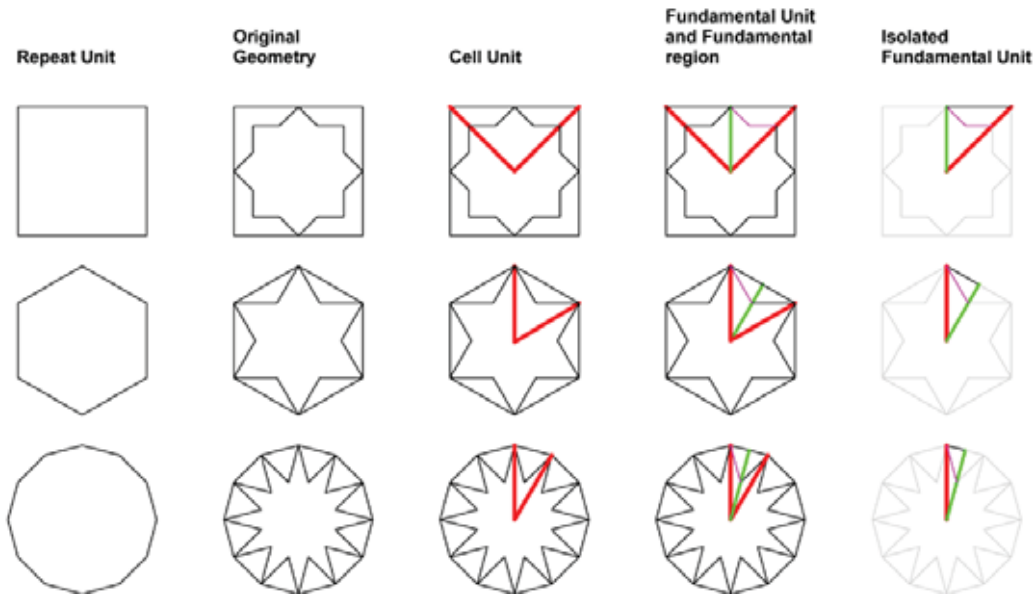

Figure 1: Identifying the fundamental unit. The cell unit is in red, the fundamental region limits are in green, and the fundamental unit is shown in pink.

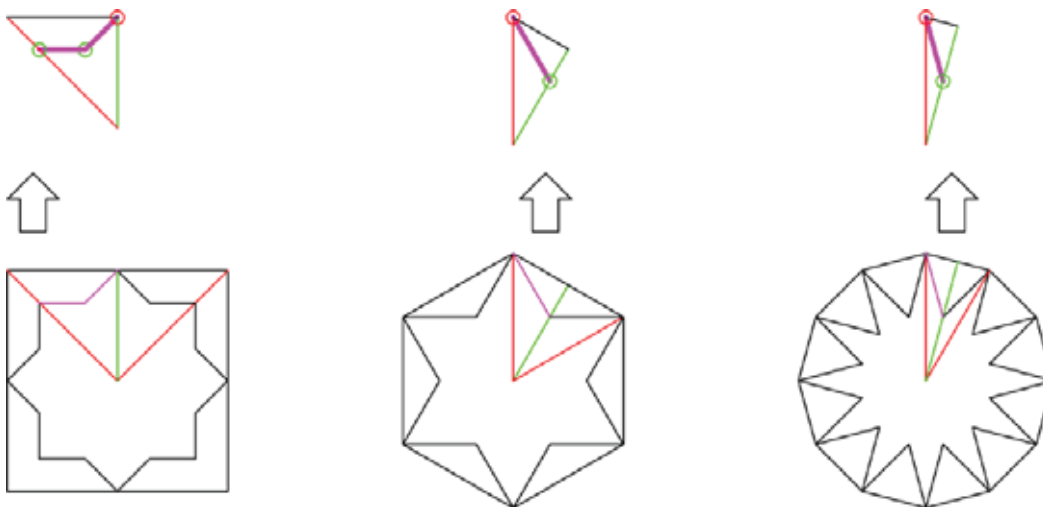

Figure 2: Building the parametric model of the fundamental unit.

2.3.1. The first approach

Qualitative Variant. In this section we discuss the first method in which the manipulation of the geometry should result in a new geometry qualitatively different from the original geometry.

Rules for the First Approach: New geometries can be generated by following set rules that should apply to all the points within the fundamental region. First, at least one point should overlap. Second, lines not allowed to overlap. Third, no additional intersections are allowed. Finally, points should not leave the fundamental region.

Results of the First Method: In this section, we apply the first approach on the six-point star and the eight-point star. For the six-point star, there is only one parameter to control because it contains only one constrained point. However, the eight-point star has two points to control, and more geometries are therefore possible. See the figure 3.

Each geometry in the previous figure has different qualitative properties. The number of points, line segments, and faces is different in the new geometry. In fact, if we apply the same rules from the first

method again, we will not be able to reach the original geometry, which is caused by the overlapping that engenders a reduction in the geometry's components.

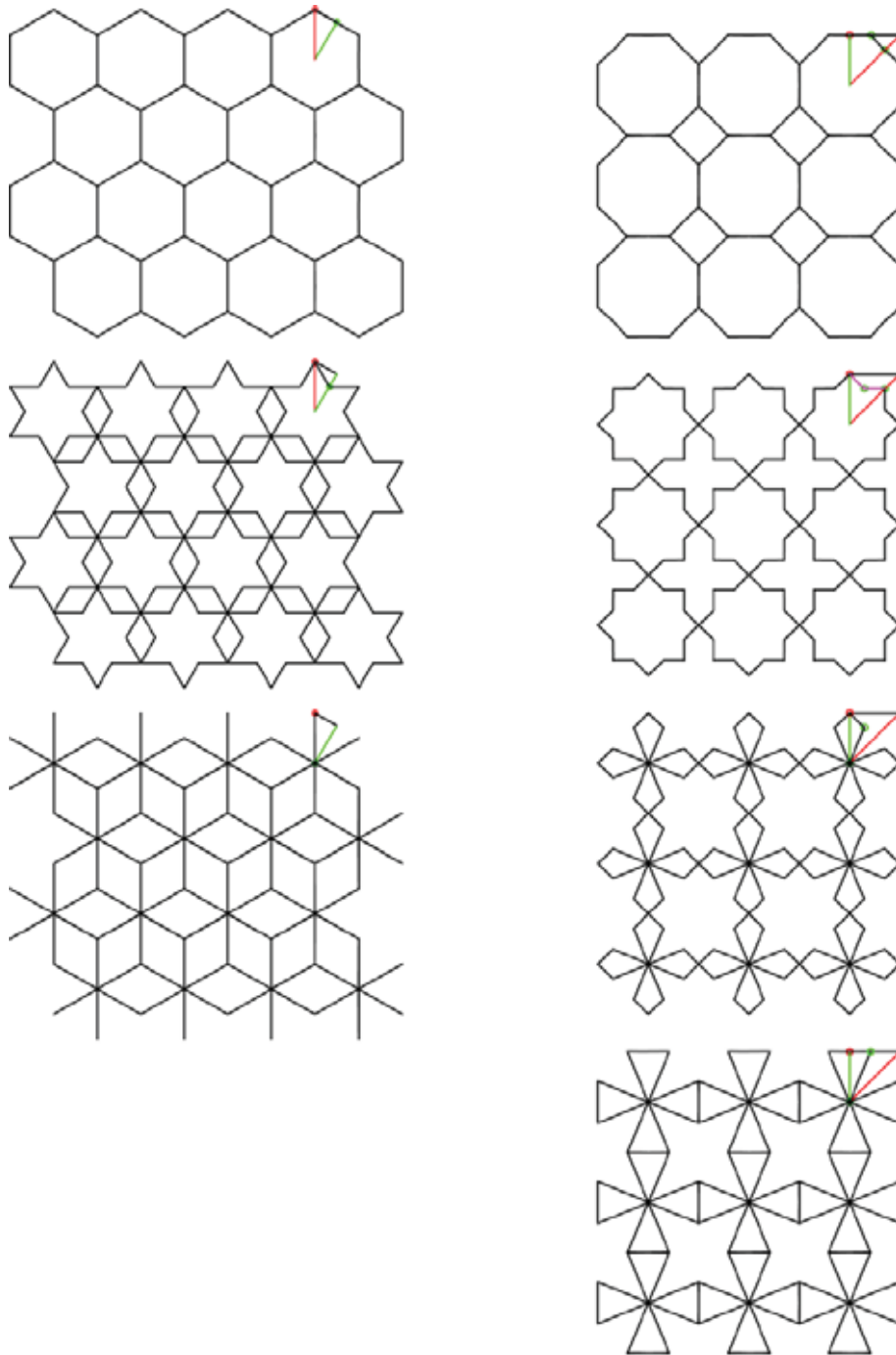

Figure 3: Series of qualitative transformation of two different patterns. Left, six-point star geometrical pattern. Right, eight-point star geometrical pattern.

2.3.2. The second approach

Qualitative Invariant. In this section we discuss the second approach, in which manipulation of the geometry should not result in a topological transformation; the new geometry should be always qualitatively same as the original geometry. The number of points, edges, and faces in the resulted geometry should be always equal to that of the original geometry.

Rules for the Second Approach: New geometries can be generated by adhering to the following rules, for all the points within the fundamental region: First, no point overlap is allowed. Second, line overlapping is not allowed. Third, no additional intersections are allowed. And finally, points should not leave the fundamental region.

Results of the Second Method: In this section we apply the second method on the six-point star and eight-point star. It should be noted that the original geometry and the new geometry are qualitatively invariant. See figure 4.

Reapplying the rules will always return the new geometry to the form of the original Islamic geometry because this method does not cause any reduction in the geometrical components.

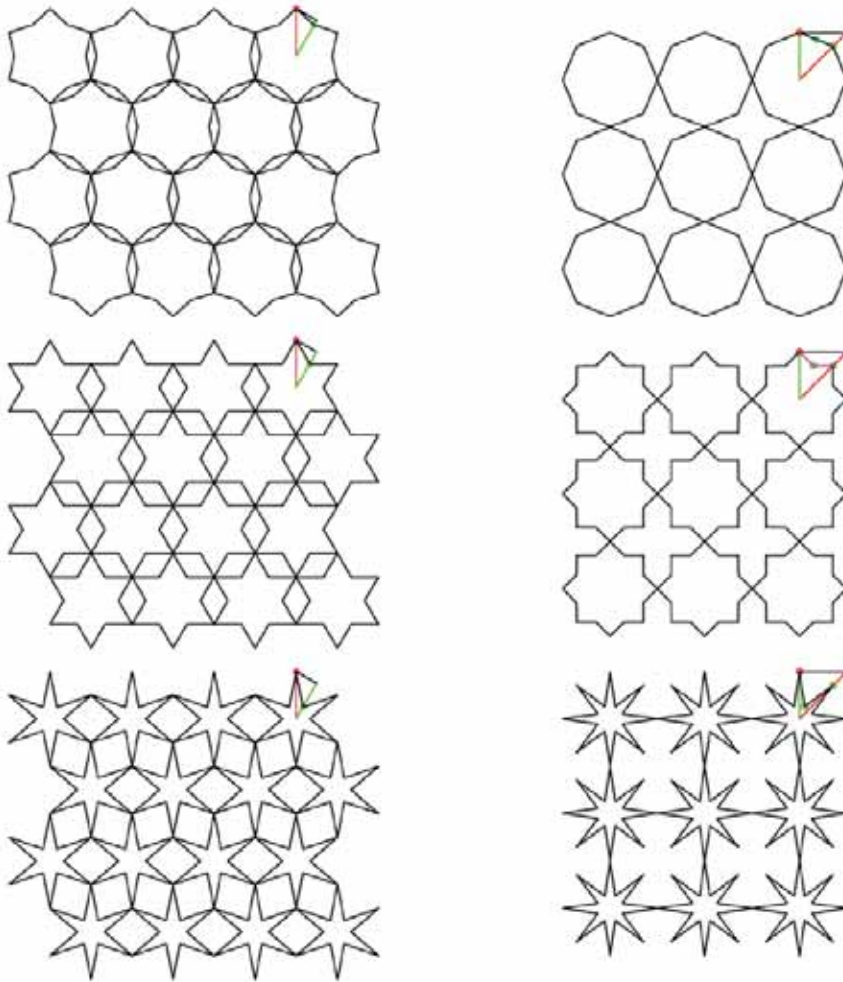

Figure 4: Qualitatively invariant patterns. Left, six-point star geometry. Right, eight-point star geometry.

2.3.3. Metamorphosis approach

To morph the geometry in relation to time, one needs to apply the rules from approach one and approach two and assign different values to the parameters at different points in time. In other words, this approach combines both approaches and adds a time factor, thus broadening the search domain, guiding and easing the exploration process.

Rules of the Metamorphosis Approach:

1. All constrained and linked constrained points of the geometry should be relocated to the center of the polygon. Consider the geometry marked "A" in figure 5. If we relocate all the constrained points to the center

of the geometry, we will have the geometry marked “B” in figure 5. As it is shown, all green circles are on the center.

2. The next step is to release one point at a time (Figure 5 C) until the point reaches the limits of the fundamental unit (Figure 5 D). Then, we release the other point one step only (Figure 5 E) and move the first point back toward the center of the polygon (Figure 5 F), the point stops if it intersect line, overlap another point, or the point leave the fundamental region (Figure 5 G). This procedure will allow us to explore the design domain for both previous approaches. A point can travel a specific distance within a specific amount of time. The time and distance are variables.

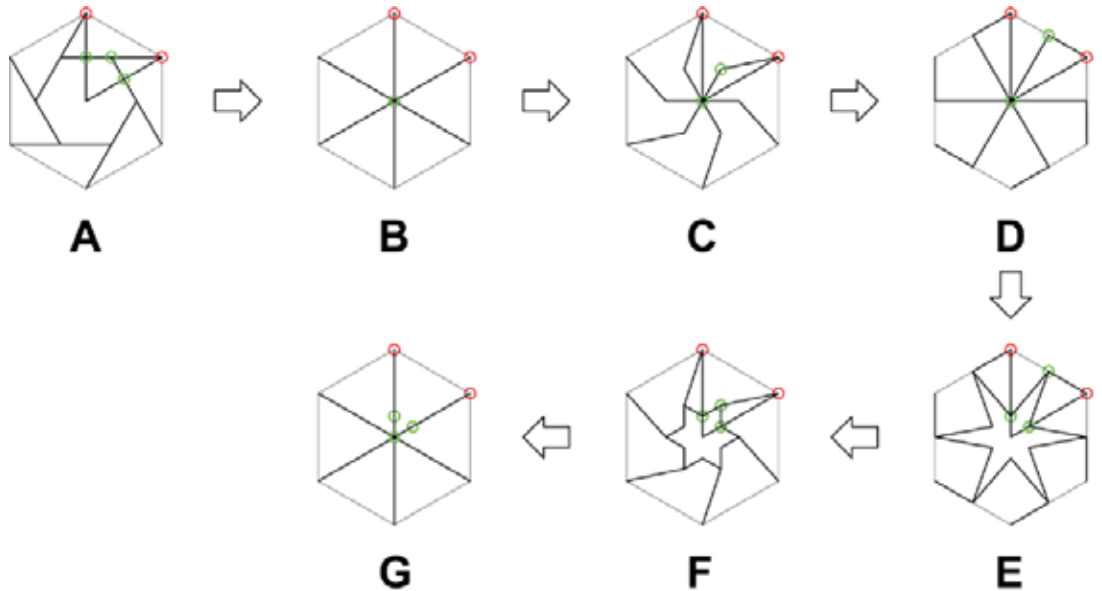

Figure 5: Metamorphoses of Islamic geometry (the seed unit).

All of these geometries in figure 5, except F, have fewer points, and so they are topologically different from A. If the other points were released and all the rules from the second approach were applied, we would be able to get back to the topology of the original geometry. Figure 6 illustrate the rules of the third approach. In this example, there are only two parameters to control. Different geometries may have more parameters and that will make the exploration process longer and more complex, but by using the specified procedure, it is indeed achievable.

Results of the Metamorphosis Approach:The results of the third approach, in the previous example, revealed that the original geometry we used to initiate the process, circled in blue in figure 6, can be transformed into many geometries. Three of them were originally existing geometries, circled in green, and two of them were partially existing patterns, circled in yellow. In other words, different geometries are existed with different status of one geometry in different points in time. To confirm that, we developed a shape code of geometry, which is a numerical description that represents each status/geometric pattern (Lalvani 2003). Consider the code below:

This code describes a six-point star. It uses the Cartesian coordinate system to position points and lines that construct the geometry. Number six represents the number of cells within the geometry. The second and third lines represent the two lines that exist within a single cell unit. Each line has two constructing points. Each point has two coordinates, i.e. X and Y coordinates. It will be read as (x1, y1), (x2, y2). The lines are positioned for one cell unit. The rest of the cells are filled out by continuously populating the same lines. An expanded version of the code might include/add methods to analyze the geometry extensively and document the results of the exploration process.

DISCUSSION

It is possible for two distinct geometries that exist in traditional Islamic patterns to have same geometry topologically, but each one represents a different point in time. Consider this, El-said, in his book *Islamic Art and Architecture*, demonstrates how to generate an eight-point star. Later in the same chapter, he explains how to generate the octagonal pattern. In other words, he shows two different geometries with two different

set of rules to generate them. El-said expresses the eight-point star as A:B:A, which represents the proportions of the constructional grid, while he expresses the octagon as A+B:B. However, using the method presented in this paper, it will be possible for a designer to manipulate these proportions to reach the octagon from the eight-point star and vice versa (El-Said et al. 1993).

So back to the original question: what else can we derive? The answer is that a seemingly unlimited number of geometries can be derived by considering fractions of distance in relation to time. Now, to differentiate geometries, we need a new system that can classify based on when they occur. This predicament implies the second question as to considering the new patterns to be Islamic. If we consider the third proviso that prescribes Islamic patterns as ones derived from other Islamic patterns, then we can say with confidence that the new patterns are in fact Islamic. Furthermore, some of the new patterns seem to fit the visual imagery of the traditional Islamic counterparts, but this perhaps will require further studies to determine the degree of likeness to the traditional patterns. "Just like nature, there is a universal code, there must be one like this for architecture," Lalvani (Lalvani 2010) said in a TEDx Brooklyn talk. This method is a step toward in finding the code of the original Islamic geometries, and in generating new geometries through a guided exploration of Islamic geometry.

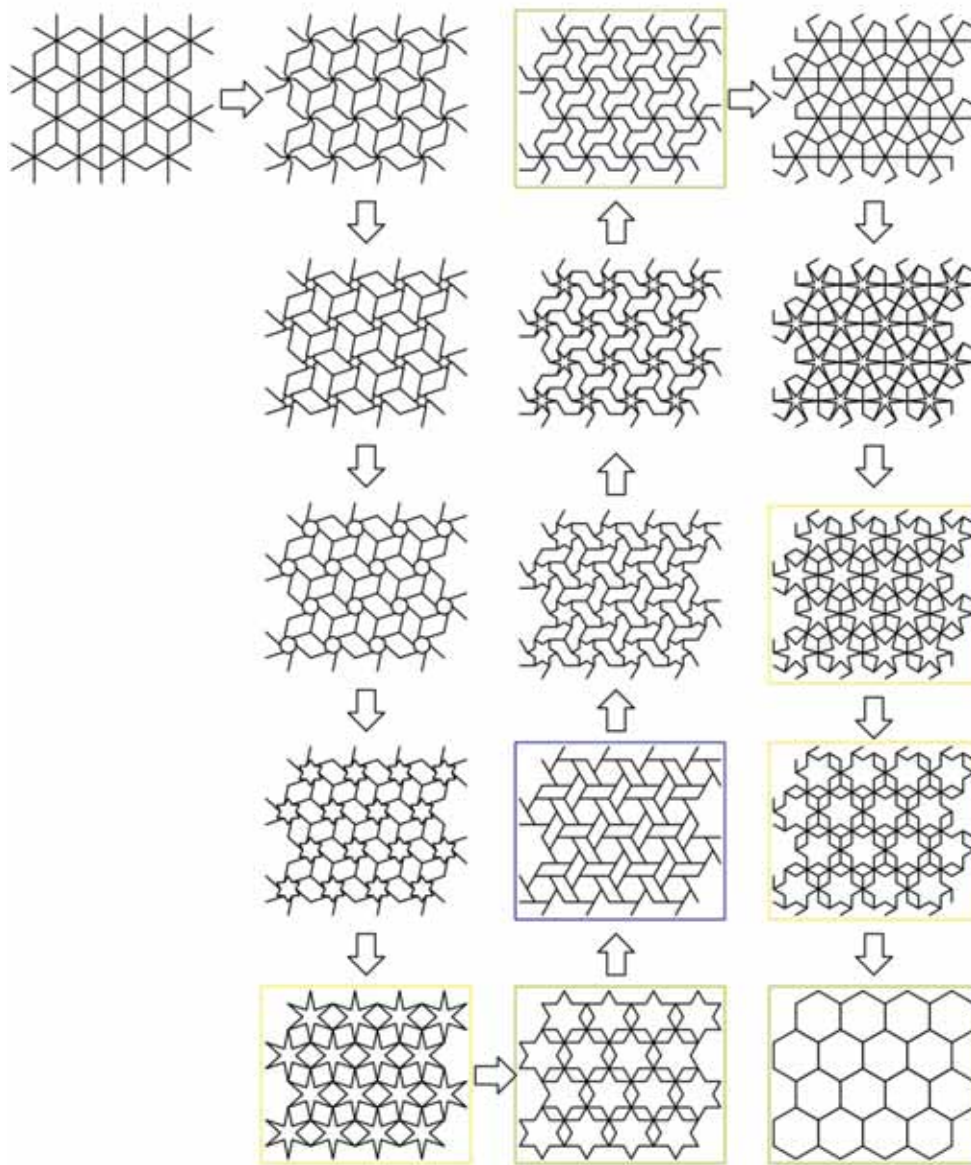

Figure 6: Metamorphoses of Islamic pattern.

ACKNOWLEDGMENT

Authors gratefully acknowledge the support of The Higher Committee for Education Development in Iraq (HCED). Also, authors wish to thank Dr. Akel Ismail Kahera for his valuable insights.

REFERENCES

- Abas, Syed Jan, Amer Shaker Salman, Ahmed Moustafa, and Michael Atiyah. 1995. *Symmetries of Islamic geometrical patterns*. Vol. 3: World Scientific.
- Al Ajlouni, Rima A. 2012. *The global long-range order of quasi-periodic patterns in Islamic architecture*. *Acta Crystallographica Section A* no. 68 (2):235-243. doi: 10.1107/S010876731104774X.
- Aljamali, Ahmad, and Ebad Banissi. 2003. *Normalization and exploration design method of Islamic geometric patterns*. Paper read at Geometric Modeling and Graphics, 2003. Proceedings. 2003 International Conference on.
- Aljamali, AhmadM, and Ebad Banissi. 2004. *Grid Method Classification of Islamic Geometric Patterns*. In *Geometric Modeling: Techniques, Applications, Systems and Tools*, edited by Muhammad Sarfraz, 233-254. Springer Netherlands.
- Barrios Hernandez, Carlos Roberto. 2006. *Thinking parametric design: introducing parametric Gaudi*. *Design Studies* no. 27 (3):309-324.
- El-Said, Issam, Tarek El-Bouri, Keith Critchlow, and Salmá Samar Damlūji. 1993. *Islamic art and architecture: the system of geometric design*. Garnet Pub.
- Izadi, Ali, Mahdi Rezaei, and Azam Bastanfard. 2010. *A Computerized Method to Generate Complex Symmetric and Geometric Tiling Patterns*. In *Intelligent Computer Graphics 2010*, 185-210. Springer.
- Kaplan, Craig S., and David H. Salesin. 2004. *Islamic star patterns in absolute geometry*. *ACM Trans. Graph.* no. 23 (2):97-119. doi: 10.1145/990002.990003.
- Kolarevic, B. 2004. *Architecture in the Digital Age: Design and Manufacturing*: Taylor & Francis.
- Lalvani, Dr. Haresh. 2010. Inventor of ALGORHYTHMS and XURF product lines.
- Lalvani, Haresh. 1989. *Coding and generating complex periodic patterns*. *The Visual Computer* no. 5 (4):180-202. doi: 10.1007/BF02153749.
- Lalvani, Haresh. 2003. *Genomic Architecture*. In *The organic approach to architecture*, edited by Christine Phillips, Deborah Gans and Zehra Kuz. Academy Press.

Method and the absence of modernism

Philip D. Plowright¹

¹Lawrence Technological University, Southfield, MI

ABSTRACT: Recent research in design methodology has developed a theory of underlying, skeletal cognitive structures on which individual, and idiosyncratic, architectural design methods are constructed (Plowright 2014). In this theory, cognitive frameworks are illustrated by connecting 19th century rationalist method development to late 20th and 21st century architectural designers with little attention to the impact of Modernism on process. As Modernism introduced strong values into architecture, the question became whether Modernist positions also introduced any new frameworks for design methods beneath the topological and representational difference that appeared to be a radical departure from then-current (late 19th century) design processes. The analysis was focused on a small corpus of influential textual evidences of two generations of "High Modernists" to examine representative positions. This research follows the traditions of Cognitive Linguistics which considers linguistic evidence as point of access to cognitive processing. The research used semantic and concordance based qualitative tools to examine the present intention and approaches to design. Semantic indicators for cognitive frameworks were developed, along with control terms that addressed project framing and approach.

Evidence in the corpus clearly showed the architectural thinking of two central figures involved in Modernism, Walter Gropius and Paul Rudolph, did not develop a new framework for approach but primarily followed the established tradition of methods based on forces and patterns. One of the most interesting findings was that today's dominant framework of *concept* was absent as a method in the text. The term, and equivalents, was widely used but it was never operationalized as value testing within method. Instead, a parallel concept of *art* was introduced in the writing to hold what was considered non-technical and non-describable content. Finally, there was a limiting of values in the initial starting state and active content to a narrow margin focused around a perceived position of social progress and a few environmental factors. Ultimately, the research identified clear framing changes (belief and values) but did not reveal any change in methodology (process and tools).

KEYWORDS: Methodology, Modernism, Cognitive Framework Theory, Discourse Analysis

INTRODUCTION

Recent research in design methodology has detailed underlying, skeletal cognitive structures on which individual, and idiosyncratic, architectural design methods are constructed (Plowright 2014). However, the exploration of a cognitive framework theory of design method connected 19th century rationalist design procedure development to late 20th and 21st century architectural evidences with little attention to Modernism as a ideological movement. As Modernist ideas introduced strong values into architecture, the question became whether designers associated with the Modern movement introduced a new framework for design methods as a radical departure from then-current (late 19th century) design processes or simply adopted those historic procedures within an alternative value structure. To say it a different way, does the topological and representational difference pursued by Modernist designers follow from changes to process structures?

In order to access the intellectual content that would give evidence to method processes, the research focused on textual evidences of a sample of Modernist positions in terms of applied procedures. The project worked from the Cognitive Linguistic position that textual and linguistic evidences are representative of cognitive processes (Croft & Cruse 2004; Geeraets et al 2006; Kristiansen et al 2006). There are many forms of architectural analysis from formal analysis of built work, analysis of architectural media or explorations of co-current cultural documents. However, this study was concerned with thinking and knowledge systems. While there is common understanding within architecture that the primary modality to access and transfer architectural knowledge is the drawing (Forty 2004, Evans 1997) as well as the completed architectural object/building (Stevens et al, 2009), cognitive decisions and framing positions are very difficult to identify without a fully documented and notated set of process evidences - something extremely rare in our design culture. An alternative source for design thinking processes can be found in written sources. Text has been an important form of knowledge transfer in architecture starting with changes in communication technology, such as the woodblock print and, later, the printing press. The advent of the pattern books of the late Renaissance and Enlightenment, such as those by Serlio, Vignola and Filarete, not only opened up architectural knowledge to laypeople but also reinforced standardization of approach. While the drawing has been called the real site of architecture (Evans 1997, 156), the transfer of architectural knowledge through text is also extremely influential. One only has to scratch the surface of the architectural community to reveal the importance of text-based communication. Books such as Vitruvius' *de Architectura* (first century, AD), Alberti's *On the Art of Building in Ten Books* (1452), Palladio's *The Four Books of Architecture* (1570), Marc-Antoine Laugier's *Essay on Architecture* (1753), John Ruskin's *The Stones of Venice* (1851-3), Le Corbusier's *Vers une architecture* (1924) and, in the contemporary period, Aldo Rossi's *The Architecture of the City* (1966), Robert Venturi's *Complexity and Contradiction in Architecture* (1966), Rem Koolhaas's *Delirious New York* (1978), Bernard Tschumi's *Architecture and Disjunction* (1994), Juhani Pallasmaa's *Eyes of the Skin* (1996), Gaston Bachelard's *The Poetics of Space* (1994), or Peter Zumthor's *Thinking Architecture* (2006) are examples of text-based position and process documentation, with little evidence of traditional drawings or other image modalities. An analysis of architectural thinking through the study of written text with a focus on latent and semantic aspects allows access to understand larger

relationships and philosophical positions. In this study, "architecture" is not considered to be the building but the thinking process by which the building emerges. This allows us to study conceptual and procedural processes independent to "what it looks like".

Working from this principle, the research project examined a corpus of writing of two generations of identified high Modernists, Walter Gropius (1883-1969) and his student, Paul Rudolph (1918-97). Both individuals occupied critical and influential roles in both the practice and education of architecture, Gropius as Chair of Architecture at Harvard University and Rudolph as Dean of Yale Architecture School. The corpus consisted of a collection of 15 essays (P1) and an extended essay (P2) on the Bauhaus philosophy authored by Gropius (50,580 and 13,364 words, respectively) and 20 articles (P3) by Rudolph (34,870 words). Both sets of articles had been gathered into edited volumes. All text in the corpus was chosen due to its explicit purpose to transfer method and philosophical positions between the authors and their intended audience – the architectural student. As such, the sample was written to explain the authors' approach and position towards architectural design, not to address a single building or as an ideological position. That is, the essays were to be instructive and pragmatic. Gropius wrote that the purpose of the writing was "to introduce a method of approach which allows one to tackle a problem according to its peculiar conditions." (Gropius 1974, 17) while Rudolph lamented that while "Geniuses probably should not be burdened with any kind of architectural school; [...] those of us who are less fortunate need some direction and a method of approaching a problem" (Rudolph 2008, 8). It was considered important that a clear value to method was found in the corpus, as well as testability that comes along with verifying outcomes (Gropius 1974, 12). Gropius' texts were written between 1937 and 1965 while Rudolph's articles are between 1952 and 1998 with a median year of 1961.

Based on the stated positions of the authors and the purpose to transfer design method knowledge to students and a wider community, the corpus was considered representative of sample of process in Modernist positions. At the same time, one must also recognize that Modernism was a large cultural movement of aligned approaches so this corpus is not, and does not claim to be, comprehensive.

1.0 THE FORMALIZATION OF DESIGN METHODS FRAMEWORKS

1.1. Rationalist foundations

The cognitive frameworks of design process were formalized during the late Enlightenment and the Rationalist movement of the 19th century. While some aspects of these structures can be found earlier in architectural treatises, it isn't until a Western society fully invested in scientific method and formalized pedagogy that these frameworks are founded as clear, repeatable structures. By the end of the 19th century, there were three recognizable information sources that drove design thinking structures – patterns, forces and concepts (Plowright 2014, 33-52).

The first truly rational architectural design method was produced by Jean-Nicolas-Louis Durand (1760-1834) and published in his book, *Précis of the Lectures on Architecture* (1802-5). Durand's text was one of the first to address architecture as an issue of design rather than a set of construction details and practices (Picon 2000, 1). This meant that not only was it the first method of architectural design based on the rational thought process of the philosopher Rene Descartes, it was also conceptual in nature rather than a practical pattern book, making it intellectually different to the popular volumes of Vignola and Serlio. Understanding architecture not as the building, but as the thought process that creates the building, was a critical shift. Durand's method presented architectural design as the application of *patterns* and *rule-sets* using composition and arrangement of elements in space to drive design decisions. Patterns, as source material, could create compositional rules and are seen by the designer to hold the best type of information to allow for relevant outcomes in final design. A framework focusing on pattern application then limits the tool selection as well as structures how decisions would be made and what type of information would be available to the designer – stressing composition and typology over cultural and social use of space. Cultural and social content is still present, only it is held in the patterns rather than being applied independently as part of the design process (Plowright 2014, 39-40).

The second major framework for architectural design is one based on forces. Although this approach differs conceptually from the application of pattern-based rules, it developed from the same rational, scientific approach as the one detailed by Durand. The force-based framework focuses on systems thinking and the negotiation of complex forces conceptualized as pressures, assets, constraints and flows. The point of the framework is to prioritize those forces as source material allowing a designer to act upon them through formal responses. Documentation of the framework can be found in Eugène-Emmanuel Viollet-le-Duc's 1873 book, *Histoire d'une maison*, although the attitude towards forces can also be found in writings as far back as the Renaissance architect Leon Battista Alberti (Plowright 2014, 186). On a process level, a force framework considers architectural form as the direct manifestation of forces, flows or pressures (Sullivan 1918; Alexander 1964; Groak 1990). Identifying these pressures through the introduction of a series of *constraints* and *assets* allows decisions to be negotiated, moving towards a final proposal. Many designers who approach their work using a *force-based* methods tend to believe that design is a problem-solving process and that design is simply the resolution of conflicting forces (Plowright 2014, 44). Problem solving of this type addresses socio-cultural and environmental levels rather than production, but also introduces fallacies of technical rationalism and positivism – i.e. that social reality is objective and fully measurable, therefore solvable.

The final identified framework, concept, is one that has aspects found in the theoretical notion of character forwarded by Gabriel-Germain Boffrand (1667-1754) and analogy as found in the Renaissance architects Alberti, Francesco Di Giorgio (1439-1502), Filarete (1400-1469) and Palladio (1508-1580) as well as the Revolutionary architects Étienne-Louis Boullée (1728-1799) and Claude-Nicolas Ledoux (1736-1806). Both positions stress coherence as the goal of the

outcomes and the major source of the model for architecture was poetry and literary arts. Boffrand believed that there was such a great affinity between poetry and architecture that it was possible to take principles from the former and apply them to the latter. In this case, it was the overall effect of poetry in terms of its expressive mood which Boffrand was interested. As such, the approach focused on aligning the parts of the composition with the intention of the whole. The concept of character became institutionalized into architectural education through the École des Beaux-Arts of the early 1800s through the use of the *parti*, or “*what characterizes a building*” (Cret 1941, 12) The Beaux-Arts approach is different to what we would consider a contemporary approach to concept as *parti* stressed formal composition over conceptual ideas and emotive effects. The contemporary framework of concept, instead, owes its structure to a rational investigation in literature through an essay titled ‘The Philosophy of Composition’ (1846) by the American poet, author, and critic Edgar Allan Poe (Plowright 2014, 252). In this essay, Poe reinforced the philosophical position Baumgarten had developed over a century before. Picking up on *artistic unity or lucid order*, Poe called for the development of a *unity of impression*. In order to have unity, there would need to be a focus. For Poe – as for Boffrand, Blondel, Boullée, and Ledoux – that focus or central idea would be first and foremost on *effect*. In architecture, this meant that concept is a top-down approach which uses a “big idea” to structure decisions within the design process unlike patterns and forces which are emergent, bottom-up processes. The *concept-based* framework revolves, then, around the creation of a central idea which is used to organize the parts of design proposal. All aspects of the design are then judged against, and should reinforce, the central idea.

All three of these major design frameworks were codified in the 19th century through the pursuit of rationalism and can be found underlying 21st century design methods, surviving both the German Idealistic position of genius and idiosyncratic self-centeredness of Romanticism (Plowright 2014). Modernism, as a major cultural movement that occurred between these two periods and as the progenitor of contemporary attitudes in either agreement or opposition, presents itself as an intervention in the intellectual life of Western Culture. As a movement, its proponents took a clear position on assessing, or abandoning, history and traditional processes in order to have a clear sense of difference between the now-future, the then-present and the past. Gropius reinforced this attitude when stating the goal of the Bauhaus was to “find a new approach which would promote a creative state of mind in those taking part and which would finally lead to a new attitude toward life” (Gropius 1974, 21). It would make some sense that Modernist positions attempted to change design methods by introducing new frameworks for the procedural operation of design.

2.0. METHODOLOGY

The research used Qualitative Data Analysis (QDA), semantic and concordance based methods accessing both word search protocols as well as close reading in order to examine intention and approaches to design in the corpus. Semantic indicators for cognitive frameworks were developed using major equivalencies mapping to information sources. In addition, control terms were introduced that addressed generic project framing and approach to capture concepts external to the frameworks. Coding of the corpus occurred using ATLAS.ti 7.5.0 qualitative data analysis workbench. The predetermined code list was used to tag the text on a full, close read in addition to in vivo, or constructed, coding for relevant but unexpected aspects of text. Once the text was fully tagged, a second pass was activated using the developed code list as a automated word search to determine if any instances had been missed. On completion of the coding, the indicator terms were examined for concordance, or what context the term was persistently applied.

2.1. Semantic indicators and concept hierarchy

The major hierarchical categories for qualitative coding were references to general design methods, force-based frameworks using systems and emergence indicators, pattern-based frameworks using type and rule based indicators, and concept-based frameworks using coherence indicators. Each of these categories was tagged for presence, and any sub-categorical factor was noted independently. In general, the counts from these indicators denote the physical presence of the word (strict word count) but for more complex indicators, such as “fuzzy repetition” or “relationship between phenomena”, the matching concept in the text was tagged without explicit word use.

In addition to the predetermined codes, in vivo codes were developed as part of discovery of concepts in the corpus (grounded theory approach). These additional codes include art, artist, project method, environmental references (sunlight, air, biophilia, climate), human relationships, social responsibility, genius, problem-solving and affect. They reflected themes dominant in the corpus related to method theory but not part of procedural or framework structure. Finally, an open code was maintained for any reference to design factors that did not meet the force, pattern or concept indicators. This code would alert for the presence of an alternative underlying framework for design process prioritized by Modernism procedures.

2.2. Word presence and density

The research data showed interesting trends even on a basic quantitative level through word or concept occurrence and density (Table 1). First, all predetermined codes were discovered in the corpus with clear indicators towards method approach and value structures. While there were only 26 occurrence of an explicit reference to a method (0.07% density), indicators for the three major frameworks occurred 740 times with a minimal density of 2% based on discrete word presence rather than entire scope of semantic boundary, making this a significant presence. Other dominant concepts found within the corpus were references to art and problem-solving.

There is also a difference in presence of indicators found in the Gropius or Rudolph sections of the corpus allowing some speculation on diachronic effects of concept embeddedness in method approaches. The major Gropius section is balanced between force and pattern references (both 0.05% density) but with dominant pattern references when looking at all indicators under this category (total of 97 or 0.19% density for pattern rather than 46 for force). The presence of pattern based indicators in Gropius’ text is unsurprising considering his focus on type and repetition in industry. However,

while the Rudolph text was more urban focused overall, it had a significant deficit of pattern indicators that usually thrive in urban design contexts. A postulation would align this drop with the suppression of pattern-based approaches in the mid 20th century before they resurfaced in the 1970s through the typology and typo-morphology movements (Plowright 2014, 146). There was also a significant increase in the use of concept-based terms in Rudolph compared to Gropius, with a rise from 0.08% density to 0.25% density which suggests changing attitudes to architectural image values which encouraged the use of more "acceptable" design processes.

There were several exceptions evidenced through their absence from the quantitative data. First, there was no reference to any indicators besides those generated by the three design frameworks formalized in the 19th century. The second major absence a lack of reference to explicit design information internal to the method other than a few references to air movement, climate and sunlight. Although there were references to social and cultural factors, these statements were disconnected from discussion of methods themselves.

Table 1: Semantic indicators occurrences and density

	Gropius – 1974 (1937-65)		Gropius – 1998 (1965)		Rudolph – 2008 (1952-98)		Total
	Total Word Count: 50,580		Total Word Count: 13,364		Total Word Count: 34,870		
	Occurrences	Density	Occurrences	Density	Occurrences	Density	
METHOD - design	14	0.03%	2	0.01%	10	0.03%	26
METHOD - project	7	0.01%	0	0.00%	0	0.00%	7
FORCE FRAMEWORK REFERENCE	27	0.05%	4	0.03%	32	0.09%	63
Asset	0	0.00%	1	0.01%	0	0.00%	1
Circulation - pedestrian	0	0.00%	0	0.00%	3	0.01%	3
Circulation - vehicular	3	0.01%	0	0.00%	4	0.01%	7
Economics	6	0.01%	0	0.00%	0	0.00%	6
Flow	1	0.00%	0	0.00%	0	0.00%	1
Push	1	0.00%	0	0.00%	0	0.00%	1
Relationship between phenomena	7	0.01%	1	0.01%	11	0.03%	19
Relationship to environment	1	0.00%	0	0.00%	4	0.01%	5
PATTERN FRAMEWORK REFERENCE	26	0.05%	1	0.01%	5	0.01%	32
Arrangement	1	0.00%	0	0.00%	0	0.00%	1
Composition	11	0.02%	1	0.01%	1	0.00%	13
Configuration	0	0.00%	0	0.00%	4	0.01%	4
Fuzzy repetition	4	0.01%	0	0.00%	0	0.00%	4
Organic development/evolution	2	0.00%	0	0.00%	0	0.00%	2
Pattern as design quality	5	0.01%	0	0.00%	0	0.00%	5
Pattern as spatial order	2	0.00%	0	0.00%	0	0.00%	2
Rule	5	0.01%	0	0.00%	0	0.00%	5
Type	19	0.04%	4	0.03%	3	0.01%	26
Typology	10	0.02%	0	0.00%	2	0.01%	12
Urban pattern	12	0.02%	1	0.01%	11	0.03%	24
CONCEPT FRAMEWORK REFERENCE	5	0.01%	1	0.01%	35	0.10%	41
Approach	16	0.03%	0	0.00%	12	0.03%	28
Coherence	3	0.01%	0	0.00%	6	0.02%	9
Idea	14	0.03%	7	0.05%	20	0.06%	41
Notion	0	0.00%	0	0.00%	14	0.04%	14
Position	1	0.00%	0	0.00%	0	0.00%	1

OTHER FRAMEWORK REFERENCE	0	0.00%	0	0.00%	0	0.00%	0
ENVIRONMENTAL REFERENCE	3	0.01%	0	0.00%	0	0.00%	3
Air movement	2	0.00%	0	0.00%	0	0.00%	2
Air temperature	1	0.00%	0	0.00%	0	0.00%	1
Biophilia	1	0.00%	0	0.00%	0	0.00%	1
Sunlight	6	0.01%	0	0.00%	1	0.00%	7
Genius	3	0.01%	6	0.04%	9	0.03%	18
Art	60	0.12%	25	0.19%	90	0.26%	175
Artist	27	0.05%	12	0.09%	13	0.04%	52
Problem solving	66	0.13%	12	0.09%	76	0.22%	154

2.3. Concordance data and analysis

The coded terms were examined for congruence with the intended purpose of the research – to address persistent frameworks existing as structure for variable design method as evidenced by the corpus. The *force* and *pattern*-based codes and equivalences operated within the semantic bounds of their intended meanings. Indicators identified within the text representing the conceptual sub-categories were in alignment with the overall intentions addressing a particular aspect of the larger framework. Some environmental, economic, social and scale references were co-concurrent in both forces and pattern categories, acting as content by which the method would arrange values. These were found in several sub-categories as well as the main tag under *forces*. In *pattern*, however, the co-occurrence was almost exclusive to the *rules* tag with some relationship to *type* (as a rule). Under environmental references, sunlight was the most populous occurrence (5 in forces and 7 in pattern across the corpus) while forces had more raw references (34 compared to 16 in pattern). This is not unexpected as these factors are more explicitly used in force-based approaches as dynamic effects of non-formal information in shaping formal responses through relationships. In pattern, the same information drove a series of compositional guiding rule-sets but is less visible in process. This is in alignment with cognitive framework theory. No other force or pattern-based source material was addressed in the corpus other than that referenced in Table 1, evidence of a scarcity of primary data for design decisions. The Gropius sample also made multiple references to testing design for acceptance with the public (*field-test* was Gropius' term). There was no evidence of this attitude in the Rudolph sample.

The concordance relationship became problematic when looking at the *concept* tag and concept-based equivalents. While concept-based frameworks stress coherence using an overriding idea through the alignment of parts, there was no indication of this specific understanding in the corpus. There was, however, a diachronic shift in the use of the term between the Gropius and Rudolph samples (discussed in Section 3). In addition, when concept was referenced in alignment with the code's intention, which occurred only in the Rudolph sample, it correlated with negative statements in the post-1969 text samples. Both *approach* and *notion* were an equivalence for the term *method* as a general statement. These two sub-categories consistently meant an attitude or a philosophical position towards the design or building, rather than a procedural structure to generate the design or building. As such, there is little alignment with the terminology and the concept-based framework structure making this approach basically absent in the corpus.

Problem-solving, as a term, occurred throughout the corpus and acted, in context, as an equivalence to the term *design*, while method was considered as a way to approach a problem (Rudolph 2008 8). Both Gropius and Rudolph stressed that the role of architecture was to solve societal problems rather than technical ones – Gropius concerned with social progress while Rudolph addressed issues of scale, the automobile and human response. The strongest relationship of *problem-solving* with framework codes was co-concurrence with *concept* tags as well as some connection to *forces* through *economics*. There is little connection to *pattern*. Of the three co-occurrence present, the two in the Gropius sample are negative (critical of existing patterns), while the Rudolph sample has a only one co-occurrence between pattern and problem-solving which addresses precedent as a form of knowledge.

3.0 DISCUSSION

Evidence in the corpus clearly showed that at least these representatives of two generations of Modernist architectural thinking did not show evidence of a new framework for design method but primarily followed the 19th and early 20th century tradition of Eugène-Emmanuel Viollet-le-Duc and Frank Lloyd Wright (*forces*), as well as Jean-Nicolas-Louis Durand (*patterns*). References and semantic indicators to method approaches were found throughout the text supporting both these framework positions. However, the term *method* was not consistently applied in the corpus to mean the procedural actions in the process of design. When Gropius and Rudolph used the term, they meant a *fixed outcome to a problem*. For both, then, method was the formal solution to a "problem" not the process to achieve that solution. The idea of problem and problem-solving dominates all the text, but this isn't dissimilar to how Durand also defined architectural design and the purpose of method. Durand clearly stated that his focus in his method was to solve a problem which was a building (Durand 1802, 86) – or two problems, fitness of use and economy of cost.

Methods inferred from a force-based framework did not explicitly identify priorities of non-formal information that would shape formal responses. *Forces* had a tendency to be limited to environmental factors (sunlight/air) and included few references to social content. However, there is clear intent to use force-based information to guide decisions within design. Gropius referred to responding to climatic conditions when he wrote "diversity of expression can result from this fact alone if the architect will use the utterly contrasting indoor-outdoor relations of these two regions as focus for his design conception" (Gropius 1974, 87) and "I want [the designer] independently to create true, genuine forms out of the technical, economic and social conditions in which he finds himself" (Gropius 1974, 17). Rudolph implied support for environmental forces by criticizing the lack of their use in work by Mies van der Rohe which, he wrote, had "no sense of place or climate, or the demands of immediate access and relationships to the environment." (Rudolph 2008, 109-10). There are gestural statements towards cultural forces as well but they are left undefined and generic, connected with general spiritual-philosophical terms such as harmony, progress, and architecture as a "true mirror of life" (Gropius 1974, 66) and "to develop on a higher plane" (Gropius 1974, 20). As such, these terms are not strictly force-based information but general framing beliefs disconnected from the operational method.

Pattern frameworks, through *typology* and *rule*, were referenced in the Gropius sample but had a tendency to vanish in the Rudolph sample, as noted above. When pattern indicators occurred, they were strongly aligned with urban conditions and urban scale design with minor references to floor composition in housing. They did not connect social patterns with building form although support for traditional use of space can be found in both sections of the corpus. Ironically, Rudolph made the strongest expression in support of pattern-based methods when he stated that a designer can "go back to age-old principles. I think there are definite and definable theories, on how to relate volume to volume, mass to mass, texture and scale; the relationship of a building to the ground, to the sky, to neighbors. I really believe that you can define X number of approaches" (Rudolph 85). This is ironic since there little support for this statement in the semantic indicators addressing pattern approaches throughout his portion of the corpus although the intention foreshadows Christopher Alexander's *Pattern Language* by 15 years.

While both force and pattern-based frameworks are supported through evidence of indicators within the corpus, it is the concept-based approaches which are interesting in relationship to cognitive framework theory.

3.1. Shifting understanding of concept

Concept-based approaches to design operate through a coherence of parts in alignment to an overall goal and are strongest when the conceptual position can be translated and responded to by multiple dimensions of the design response. The original intent of 19th century methods using this framework was to map emotive intentions towards spatial effect giving a sense of expression to built form. As the approach was institutionalized by 19th century French architectural theory in the École des Beaux-Arts, concept or the conception of a building took on distinctly spatial content using the parti and the croquis as guides to the overall composition. Twenty-first century architectural designers tend to use concept-based approaches to stress external content (non-architectural) translated into architectural forms as a narrative overlay (Plowright 2014, 245) rather than then 19th century formal strategies.

Evidence of the changing use of concept-based approaches can be found in the corpus. When Gropius used the term *conception* to address building design, it generally meant the mental act of conceiving the spatial organization of a building, as what occurs before "realization" or the construction of a building (Gropius 1974, 64). In context, the term carries the same meaning as the Beaux-Arts use as found in the parti – an idea to organize the spatial composition of a building. The sense of use is somewhat confused in Gropius by being blended with indicators for truth and essential nature as in "my own ideas began to crystallize as to what the essential nature of building ought to be" (Gropius 1974, 47). This rhetoric connected the representation of the building to a perceived sense of social reality and timeliness but did not directly engage formal composition or formal strategies with those values.

It is the Rudolph section of the corpus that we find some indication of a shift in design methods using concept – moving from spatial conception to mapping visual and relational characteristics of an idea. The core term in the category moved from "conception" to "concept" between Gropius and Rudolph and there is a large increase in overall indicators in the later writing suggesting a rise of either use or discussion in the architectural community. Rudolph, dismissive of the Beaux-Arts system as unable to address "modern problems" (Rudolph 2008, 39), clearly used concept in alignment with that École des Beaux-Arts tradition. In agreement with Gropius, concept meant an organizing device for spatial composition and formal response (Rudolph 2008, 40, 54,108). There were two instances in the Rudolph text of concept not being used in this way, however. Rudolph referenced other architectural designers using concepts of "skin and bone" (Rudolph 2008, 17) and "goldfish bowls" (Rudolph 2008, 41) – visually heavy, attribute-based concepts using domain mapping (Plowright 2014, 107-30). The 19th century approach to concept did not transfer knowledge from other domains but used internal architectural content using sensori-motor information (axis, mass, void, edge, etc). These new occurrences of concept rely on non-architectural ideas being manifested or expressed in architectural form. Rudolph recognized the difference through value statements, dismissing this alternative information source for design expressing a lack of interest in "cartoons of architecture" (Rudolph 2008,133).

3.2. Design as art, designer as artist, and suppression of method

The problem of concept in terms of method can be found in the semantics of the corpus. In both the Gropius and Rudolph samples, the architect is considered to be, and taught to see themselves as, an artist. Architecture, therefore, is an artistic act and concept, in the sense of a way to approach a building design, is then aligned as a way to achieve an artistic outcome. Rudolph went so far to stress that concept is necessary for art when he wrote that the "harmonious relationship of parts eludes most architects today. Unless there is a single generating idea—an idea strong enough to bind all parts into a whole—no work of art will emerge" (Rudolph 2008, 95). While this statement is clearly addressing

coherence in a concept-based frameworks, the outcome was considered to be art as design. For Gropius, it is a sense of art that allowed a designer to understand their conceptualization so the design can be "the outcome of knack or creative impulse" (Gropius 1965, 58) and be elevated to a higher plane – more truthful, more essential and more spiritual.

More than just concept, it seems that architecture was defined by art regardless to the framework approach. The issue for the evidence of methods becomes a position that extends from an idea found throughout the corpus introduced by the art alignment. Namely, that design as art cannot be taught and then, by association, methods can not be known. Gropius stated that that "it is through a creative attitude and independence of conception that [the student] will arrive at basic convictions, not by accepting ready-made formulas." (Gropius 1974, 56) and that:

"Art, in fact, is not a branch of science which can be learned step by step from a book. Innate artistic ability can only be intensified by influencing the whole being, by the example of the design master and his work. Whereas the technical and scientific subjects can be learned by progressive courses of lectures, the training in design must, to be successful, be conducted as freely as possible, at the personal discretion of the artist" (Gropius 1974, 28)

For Gropius, art was a natural outcome as warranted by the goal of the Bauhaus to elevate production by reconciling the otherworldly creative artist with the "workaday world of realities" (Gropius 1974, 79). Gropius went as far to stress that art, as the way to approach problem-based design processes, was something innate to an individual. It was only through the intuitive that profound art could be created by naturally creative individuals. The role of the academy, the educational establishment, was to "sift out the artistically gifted" (Gropius 1974, 223) and provide a rigorous context for future work that is pursued independently.

Rudolph was clearer regarding teaching design, stating that "schools approach architecture as a creative art, but creativity cannot be taught" (Rudolph 2008, 93). Intuition and personal expression links design processes of the artist with the concept of genius in the Kantian definition of term. Genius uses intuition to understand the rules of aesthetic judgment before the rules are defined to conscious cognition (Kant 1892, 193). Yet, ironically, Gropius and Rudolph are dismissive of the value of genius – Rudolph more so than Gropius – looking for a more populist position as social progress through collaboration (Gropius 1974, 79), need for architectural education (Rudolph 2008, 8) and a critique of individual expressionness (Rudolph 2008, 25). These positions are aligned with the value of knowing and applying method creating quite a tangle of contradictions. Architecture can only succeed when the practitioner is an artist and new methods need to be developed for new problems. Yet, art processes cannot be known but occur through innate genius, while at the same time genius is not valued as collaboration is necessary (Gropius) or so rare to be unattainable (Rudolph). Concept, as an approach, waivers between a Beaux-Arts formal principle and an artistic vision while both are denied as positive values, leaving confusion to how to apply method to architectural design.

CONCLUSION

The research succeeded through its failure to identify the introduction of new methods or frameworks through Modernism. While there were clear indicators in the corpus that Modernist positions supported a change in starting bias and pre-method philosophical intentions, ones that aligned architectural design with social progress and cultural development, there was no evidence of changes in process itself. The focus on social problems and concern for cultural expression affected changes in material choice, spatial comprehension and social alignments but the semantic content of the corpus supported the continuation of 19th century design methods. Information sources remained stable with patterns, forces and concept identifiers present. While framing of cultural values influenced the starting position and many of the selection choices within the procedural processes of architecture design, they *did not affect* the cognitive framework on which those processes are built. In addition, there was a general lack of visibility of explicit methods in the corpus as well as a paucity of information categories that would affect methodological choices – mostly limited to some environmental effects.

The larger, and more interesting, aspect of the research was the effect on method when the conceptualization of design was blurred with art, something that occurred through these Modernist texts. This sense of designer as artist has possibly operated to suppress the role and visibility of methods in architecture. The combination of clear indicators of framework orientation in the corpus yet lack of explicit discussion of methods created a conflict of intention in the texts. Both authors expressed a belief that new approaches for design must be developed and they both stressed the need to understand and apply methods. Yet, a parallel concept of *art* as indescribable and unstructured was introduced in the corpus to hold what was considered non-technical - essentially social content – obscuring, and even suppressing, any explicit method. What is interesting is while both designers in the corpus were clear about their intentions to make design more accessible and more visible through method, neither acted on those intentions beyond that statement. Ultimately, design was to produce outcomes through intuition, not through method.

REFERENCES

- Alexander, Christopher. 1964. *Notes on the Synthesis of Form*. Cambridge, MA: Harvard University Press.
- Cret, Paul P. 1941. "The Ecole Des Beaux-Arts and Architectural Education." *Journal of the American Society of Architectural Historians* 1 (2): 3-15.
- Croft, William and D. Alan Cruse. 2004. *Cognitive Linguistics* Cambridge University Press.
- Durand, Jean-Nicolas-Louis. 2000. *Partie Graphique Des Cours d'Architecture Faits a l'Ecole Royale Polytechnique Depuis Sa Réorganisation; English: Précis of the Lectures on Architecture; with Graphic Portion of the Lectures on Architecture*. Texts & Documents. Los Angeles, CA: Getty Research Institute.
- Evans, Robin. 1997. "Figures, Doors and Passages." In *Translations from Drawing to Building and Other Essays*, 55-91. London: Architectural Association Publications.
- Forty, Adrian. 2000. *Words and Buildings, A Vocabulary of Modern Architecture*. London: Thames & Hudson.
- Geeraerts, Dirk, Rene Dirven, and John R. Taylor. 2006. *Cognitive Linguistics: Basic Readings* Mouton de Gruyter.
- Groak, Steven. 1990. *The Idea of Building: Thought and Action in the Design and Production of Buildings*. London: E & FN Spon (Taylor & Francis).
- Gropius, Walter. 1965. *The New Architecture and the Bauhaus. Uniform Title: Neue Architektur Und Das Bauhaus. English*. The M.I.T. Paperback Series,; MIT21. Cambridge: Mass., M.I.T. Press.
- . 1974. *Scope of Total Architecture*. New York: Collier Books.
- Kant, Immanuel and J. H. Bernard. 1892. *Kant's Kritik of Judgment*. London ; New York: Macmillan and Co.
- Kristiansen, Gitte, Michel Achard, Rene Dirven, and FJ Ruiz de Mendoza Ib'anez. 2006. *Cognitive Linguistics: Current Applications and Future Perspectives*. New York: Mouton de Gruyter.
- Picon, Antoine. 2000. "From "Poetry of Art" to Method: The Theory of Jean-Nicolas-Louis Durand." In *Précis of the Lectures on Architecture; with Graphic Portion of the Lectures on Architecture*. Translated by David Britt, edited by Jean-Nicolas-Louis Durand, 1-68. Los Angeles, CA: Getty Research Institute.
- Plowright, Philip. 2014. *Revealing Architectural Design: Methods, Frameworks & Tools*. Oxon: Routledge.
- Rudolph, Paul. 2008. *Writings on Architecture*. New Haven and London: Yale School of Architecture.
- Stevens, James, Philip Plowright, and Anirban Adhya. 2009. "Rethinking Models of Architectural Research: We don't do Objects." *Enquiry* 6 (2): 25-32.
- Sullivan, Louis. 1918/2012. *Kindergarten Chats and Other Writings (Documents of Modern Art)*. New York: Dover Publications.
- Viollet-le-Duc, Eugène-Emmanuel. 1876. *How to Build a House: An Architectural Novelette*. Translated by Benjamin Bucknall. 2nd ed. London: Sampson, Low, Marston, Searle, and Rivington.

Neither here nor there: Housing Americans in the Italian countryside

Christina Bollo¹

¹University of Oregon, Eugene, OR

ABSTRACT: This paper is an analysis of the morphology and typology of housing in the communities surrounding Aviano Air Base, Italy. The primary research question is this: Did the U.S. Military provide housing for its members that allows for familiarity and camaraderie but also fits the architectural and cultural context of the host country? What is the role of this housing in the changing context of US military involvement abroad?

This paper assesses the initial specifications and incentives for off-base housing created by a United States Air Force (USAF) program called Built to Lease (BTL) and analyzes whether the requirements may have resulted in housing that is not socially and economically sustainable. The paper compares the BTL Housing with the Housing on the Economy through a series of typological and morphological dyads, including: townhouses versus flats, carports versus underground garages, and yard versus balcony. These communities illustrate key differences between what BTL required and what the Italian market provides.

The results of the study show stark discrepancies between the housing created by Built to Lease and Housing on the Economy. The analysis reveals that since the BTL housing was released onto the private market, neither Italians nor Americans are attracted to it; as a result, it appears to suffer an extreme vacancy problem, as evidenced by the fieldwork. The Italian developers have put several of the communities up for sale, and it is unclear what the future will hold for these oddly inappropriate communities, neither American enough for the Americans, nor Italian enough for the Italians.

KEYWORDS: Housing, Military, Italy imperialism, Economics

INTRODUCTION

In 2000 there was a deficit of available housing near Aviano Air Base; in response the USAF initiated the Built To Lease (BTL) program, and Italian developers created 530 new dwellings in Northeastern Italy. For 10 years these dwellings were leased by the USAF for the exclusive use of its service members, essentially functioning as on-base housing, off_base. In 2010 the leases expired and the BTL housing became unrestricted, still available to USAF families but not reserved exclusively for their use. The BTL housing competes with housing in the community offered by private landlords that meets Air Force standards. The spatial and architectural attributes of housing created through BTL are very different from the typical housing in the region.

This research was initiated to answer the question, what is happening to these dwellings now? Given the fact that the program ended, was it economically and environmentally sustainable to build them in the first place? How did and does the program influence housing in these communities?

There is very little interaction between USAF families and their Italian neighbors outside of the shared housing economy. It is vital that this relationship, with serves as an ambassadorship for the US, take cultural appropriateness into consideration. To an Italian, the wastefulness of vacant, relatively new housing must seem astounding. The U.S. government houses military personnel in locations throughout the world, and if we do not provide a culturally appropriate built environment we risk endangering the relationships we rely on with the host countries.

1.0 Research methods

The methods for data collection included an inventory of existing housing; direct observation of Built to Lease communities; direct observation of advertised and approved Housing on the Economy; interviews with key stakeholders at Aviano Air Base; and archival research in Italian newspapers and social media. The methods relied on triangulation of Italian and American sources and also relied on the primary investigator's previous experience researching on-base military housing in the United States. The analysis method employed was Grounded Theory, which enabled a thorough understanding of a diverse set of quantitative and qualitative data. The analysis was conducted through constantly comparative memo writing.

1.1. Housing classifieds inventory

The research began with an inventory of the housing available through three websites for finding housing near Aviano Air Base. The first, AHRN.com is common to all US bases worldwide. It is easy to search by city

and had the largest total number of ads. AvianoHousing.com was created specifically for Aviano's unique housing conditions by housing management. Landlords initiate listings, but housing is verified and rent is set before posting. Though the mapping function works better than that of AHRN.com, a viewer cannot search AvianoHousing.com by location, which seems a lost opportunity for a system that purports to prioritize the location (and commuting distance) of the housing. Avianoclassifieds.com has posts from real estate agents and landlords, most of whom are cross-listing with either AHRN or avianohousing.com. Interestingly, the site also has advertisements for housing that USAF families are leaving: "I am the current tenant. The landlord is truly great." There is a readily apparent mix of the desire to help incoming families and the desire to help someone who has been a good landlord.

These three housing resources are easily accessed and analyzed, before and during the fieldwork phase. They helped planning the fieldwork trips and understanding the range of housing available, both the BTL stock and conventional housing on the economy.

1.2. Interviews with stakeholders

Mike Toriello, the deputy commander for the US Air Force side of the base, was an essential informant of the history of the housing. Tammy Hardt, the director of Housing, gave a nuanced history of the BTL process. She was on her second tour at Aviano; the first had been 12 years before when BTL was initiated. The interviews were helpful not only for the information they elicited verbally but also because Hardt made printed copies of the plans for each of the BTL communities available for analysis

1.3. Direct observation

Housing on the Economy (HOTE) was visited and evaluated in the two largest towns, Pordenone and Sacile, as well as smaller towns, including Aviano, Roveredo and Ceolini. The research was scheduled for early May because families are just beginning to learn about potential reassignments but have not yet moved. This enabled the vacancy observations to be more reliable than they would be once the moving had begun. The direct observation of the Built to Lease (BTL) housing took place during the same time period.

"Evidence of Americans" (Figure 1) was collected at each study site. These observations included U.S. flags; American beer cans (which can only be purchased on base at the Exchange); square license plates with a ZA prefix; Rubbermaid, free-standing storage containers; Children's toys left in the yard (not an Italian practice); kid-sized basketball hoops; window screens; signs in English; coolers, especially left out on a balcony; and "Beware of Dog" signs attached to fences.

Evidence of Italians (Figure 2) included yards with a large number of potted plants or established gardens; Italian flags (out in full force in the month of May, though never seen at a house with American tenants); drying racks for clothes (all housing approved by Aviano Housing has clothes dryers installed). There was some evidence of other European residents, in particular Slovakian and Croatian license plate tags and flags of those countries.



Figure 1: Evidence of American residents in former BTL Housing and HOTE. Source: (Author 2014)



Figure 2: Evidence of Italian residents in former BTL Housing and typical housing. Source: (Author 2014)

The data collection methods sketches and photographs for follow-up study and analysis. All observation took place on foot in order to draw less attention to the researcher.

1.4. Archival research

Archival data collection included USAF newspapers and reports about the BTL program, including the Request for Proposals (RFP) that was collected during the interview process. Facebook proved valuable for understanding the points of view of the spouses of service members stationed at Aviano. Archives of Italian newspapers from the region showed the local impressions of Aviano Air Base generally and of the BTL program in particular.

2.0 BACKGROUND ON HOUSING AT AVIANO

2.1. The expanding U.S. presence in Europe

The history of the Aviano housing program must be viewed through the lens of a complicated cultural and political context. Approximately 4,000 U.S. service members are stationed at Aviano Air Base in Northeastern Italy. Technically, Aviano is an Italian air base that hosts NATO forces, most of whom are members of the United States Air Force (USAF). In the 1990s, as the U.S. military expanded its presence in Europe, Aviano expanded significantly, and the U.S. made large investments in the base itself, including building a Base Exchange and Commissary, Temporary Lodging, and dorms for single unaccompanied airmen, all of which were completed in 2000.

Since the USAF has had a presence at Aviano Air Base, all single senior enlisted airmen and officers and all accompanied service members lived in housing owned by Italians in the towns surrounding Aviano. During the expansion, they faced a housing crisis due to the increased demand for housing coupled with a static supply. To solve the supply problem, Aviano leadership initiated the Build To Lease (BTL) housing to quickly increase the amount of housing available. In 1998, the Air Force solicited proposals from Italian developers to supply 530 new dwelling units by 2000. The developers purchased the land and were guaranteed 10-year leases with the USAF (which they used to finance the housing). The USAF also paid to maintain the units during this period, employing Italian contractors.

Thus, for 10 years, BTL dwellings were for the exclusive use of USAF service members and their families, essentially functioning as on base housing, off base. Starting in 2010, the leases expired and the BTL housing became unrestricted, available to USAF families, but not reserved exclusively for their use. Therefore, the BTL housing now competes with housing offered by private local landlords that meets Air Force standards.

2.2. Economics of housing for military families

It is important to understand the economics of housing for military families, and to understand how the typical situation differs from both the previous and current situation for service members at Aviano Air Base. When service members are stationed in the United States, they receive a Base Allowance for Housing (BAH) on top of their salaries that is tied to rank, family size and other factors. They can choose to live on base and forfeit their BAH or live off base and use their BAH for rent, keeping whatever remains for other expenses. When service members are stationed abroad, they receive an Overseas Housing Allowance (OHA) which, again, is tied to rank and family size; but unlike the BAH, the OHA covers the rent and the difference stays with the US Military. Essentially, the actual rent is irrelevant to the family as long as the rent is below the family's OHA.

Table 1: Aviano Overseas Housing Allowance for 2014. Source: (USAF 2014)

E1 with dependents	1006 Euro
O1 without dependents	1035 Euro
O1 with dependents	1150 Euro

The Italian developers who owned the BTL housing during the ten-year lease period received the full OHA for each apartment, for every month of the year. These guaranteed rent payments were much higher than the market rents in the area at the time.

Simultaneous to the end of BTL, Aviano instituted a system of maximum rents based on objective housing criteria. The evaluation process for determining rent for each housing unit is very rigorous, based on formulas related to the size of the dwelling, attributes of certain amenities (such as outdoor space and parking), age and condition of unit, and location. Each locality has a factor (Euro/m²) that is used to determine the rent and there are three categories: the highest potential rents are in the historic centers of Sacile and Pordenone; the second highest in the towns within a 15 minute drive of the base; and the third highest in the towns farther afield.

The system allows larger dwellings to be rewarded with a larger maximum rent, though there are diminishing returns. For a dwelling of less than 50 m² the area is multiplied by 1.35; for a dwelling between 50 and 70 m² the factor is 1.25 and for dwellings larger than 70 m² the factor is 1.00. A private garage has its area multiplied by .50, while a carport or underground garage is only .20. The fact that a carport, which is quite inexpensive to construct, is “worth” the same as an underground garage, which is expensive to construct, is astounding.

The relationship between housing types and their relationship to maximum rent is also not linear. There are two categories: 1) single units, duplexes, and townhouses; and 2) apartments. Dwellings between 16 and 29 years old have the same factor for a given locality, regardless of the building type; but dwellings that are 30 years or older can rent for more if apartments, than the first category; and dwellings that are less than 15 years old (either restored or new construction) can rent for more if they are in the first category than apartments. This system prevents rent manipulation with vulnerable tenants, but it also has the potential to affect the form of housing in these Italian communities.

2.3. The ramifications of the Aviano housing situation

According to Mike Toriello, former deputy commander of Aviano Air Base, Aviano is one of the most difficult assignments for service members because of the stresses of living off base. The BTL program was comforting to some of the younger enlisted airmen and their families because the BTL communities were very similar to on-base housing. According to Tammy Hardt, service members liked living in BTL housing because of the convenience and ease, much like living on base. Aviano Air Base has the highest rate of early return for spouses of any base abroad. When a spouse qualifies for an early return to the US based on hardship, the Air Force pays for the spouse's move. If there is no hardship, the family pays for the move. (The AF does not keep track of those moves.). The Aviano Housing website warns, “Housing in Italy is definitely different than in the United States. The Housing Office continues to work with local landlords to include typical American-style amenities such as air conditioning, light fixtures, adequate kitchen counter and storage space, off-street parking, and window screens.” For service members and their families, housing plays a huge role in their abilities to perform their jobs well.

3.0 Architectural Comparison of Build to Lease with Housing on the Economy

3.1. Built to lease housing

To meet the needs of the families, the Air Force requested communities of 25 to 75 units, with 15% two bedroom units, 55% three bedroom units, and 30% four bedroom units. All buildings were required to be two stories, and the sites were required to be within a 35 minute drive of Aviano Air Base, with preference given to proposals within a 25-minute drive and a higher scoring given to those within a 15-minute drive (Figure 3). The unit and community designs were deemed the most important criterion, with 40% of the score in this area. Unit design was divided into three categories: functional arrangement, indoor/outdoor integration, and exterior appearance. Interior design was formally prioritized over exterior design.

There are many differences between what the RFP required and the conventional housing stock contained. In the interior of the unit, typical American appliances were expected: dishwashers, washing machines, dryers, and air conditioning. A significant amount of interior storage was required, including a closet in every bedroom, a six m² bulk storage room, pantries, linen closets, and attic storage with pull-down ladders. On the exterior, two parking spaces were required with at least one covered as a carport or garage. At the site level, visitor parking was required as were recreational areas, including a playground (Figure 4), basketball court and jogging trails.



Figure 3: Commuting Map. Source: (USAF 2014)



Figure 4: Typical BTL Playground. Source: (Author 2014)

Through the RFP, the Air Force was exacting a form of cultural imperialism. This was not on-base housing, within the confines of their domain. This housing was designed very specifically and intentionally for 530 American families who were living within Italian towns. Because of the size of the buildings and the lack of density, big parcels were chosen by the developers on the outskirts of existing towns, separate from them architecturally and separate in terms of the lives of the residents. Despite being built by Italians, the architectural character was so different from the existing fabric that the new communities were doomed to stand apart.

3.2. The architectural character of built to lease housing

As a visitor, the architectural language of the BTL sites became obvious: carports, pedestrian paths (jogging trails, in the RFP), and playgrounds were all signs of BTL communities. Italians do not generally build playgrounds, though some of the newer Italian communities have playgrounds, presumably to attract Americans. Basketball hoops of all sizes and states of repair are a clear visual cue of BTL involvement. Whether this was meant to be cute or ironic, BTL townhouses often had typical American rural mailboxes, with the requisite red pop-up flag, quite a strange site in a town serviced by the Posta Italia.

Built to Lease housing follows a consistent typology of two-story townhouses, generally in buildings of six units. The communities in San Giovanni, Aviano and Roveredo deviate from this pattern with a mix of duplexes connected by carports and a single-family dwelling at the end of each row. The site at San Quirino, is the only site to include townhouses and flats (Table 2). The BTL developers maximized the competitive RFP requirements and minimized their upfront costs by choosing carports for the parking at every development except Valleoncello and San Quirino. Many of the communities had a vast sea of unused surface parking for visitors, as required by the RFP. The more successful projects, including San Giovanni, had small surface parking areas at the end of each row of townhouses that could be utilized as informal play spaces for kids.



Figure 5: Typical BTL Housing Ceolini (Author 2014)



Figure 6: BTL Housing Via Oberdan. (Author 2014)

Table 2: Built to Lease Housing: (Author 2014)

Address	Town	Type	# Units	# Occupied	% Occupied	Condition	Outdoor Space	Parking	Evidence of Americans	Evidence of Italians
Via Valleoncello	Vallenoncello	Town-houses	41	8	20%	5	Front yard, Back yard	Under-ground	Y	Y
Via Kennedy	San Foca	Town-houses	26	13	50%	6	Balconies; Yards	Carport	Y	Y
Via Vajont	Maniago in Fanna	Town-houses	44	22	50%	7	Balconies; Yards	Carport	N	Y
Via Falcone	Maniago in Campagna	Town-houses	38	16	42%	6	Balconies; Yards	Carport	N	N
Vicolo dei Cuoi	Villadolt	Town-houses	31	10	32%	7	Balconies; Yards	Carport	N	Y
Via Passolini	Ceolini	Town-houses	42	14	33%	8	Balconies; Yards	Carport	N	Y
Vicolo Sapri	Ceolini	Town-houses	20	3	15%	6	Balconies; Yards	Carport	Y	Y
Via Rivata	Vigonovo	Town-houses	29	9	31%	7	Yards	Carport	Y	N
Via Toreal	Vigonovo	Town-houses	43	18	42%	7	Yards	Carport	Y	Y
Via Latisana	San Giovanni del Tiempo	Duplex	25	15	60%	8	Yards	Carport	Y	Y
Via Oberdan	Aviano	Duplex	16	3	19%	5	Yards	Carport	Y	N
Via King	Roveredo	Town-houses	58	24	41%	5	Yards	Carport	Y	N
Via Franco	San Quirino	Town-houses, Flats	23	10	43%	8	Yards	Under-ground	Y	N

3.3. The architectural character of housing on the economy

The sample of Housing on the Economy analyzed in the towns near Aviano Air Base varied from single-family houses to three-bedroom flats in seven-story apartment buildings, and many housing types in between those extremes. With very few exceptions, the housing offered was extremely well maintained and had ample outdoor space, usually in the form of large balconies.

Both Italian and American tenants living on the economy showed evidence of heavy balcony use, for recreation and display. There were ubiquitous split systems for air conditioning on the side of almost all dwellings that appeared more than 5 years old. Newer buildings and single-family houses had compressors on the roof or on the ground. The apartment buildings that were taller than 4 stories appeared to have elevators, but the smaller buildings did not.

Newer housing on the economy that is advertised to Americans seems designed to maximize the rent and to maximize the appeal to the target demographic. Large storage closets are present inside and outside the dwelling. Garages are private rather than common and underground. One landlord even showed an illicit hose bib inside a private garage to wash the car, an activity that is prohibited in Northern Italy. At one new complex in Sacile there is an American-style playground (Figure 8).



Figure 7: Typical HOTE



Figure 8: New Housing w/ evidence of Americans and Italians. (Author 2014)

3.4. Endemic vacancy at built to lease housing

The starkest commonality amongst the BTL communities was the obvious vacancy: 62% vacancy average across sites. Because the research was timed to occur before families began to move to new assignments, the results of the vacancy analysis are reliable, though there could be two extenuating circumstances: Valleoncello was being rehabilitated because of stucco problems and Vigonovo was publicly for sale.

The vacancy followed a clear pattern from site to site: the end units in a row of six townhouses were generally occupied and rarely were the middle units occupied (Figure 9). This pattern held from site to site and was not affected by dwelling size as two-, three- or four-bedroom units changed position within a row. At Villadolt, only one middle unit of 27 was occupied and all but one end unit of 14 were occupied. At Ceolini, all of the end units were occupied and none of the middle units were. This could result from acoustic privacy or from a desire for more side yard area, which the middle units lacked.



Figure 9: Typical Vacancy Condition, Villadolt. (Author 2014)

CONCLUSION

The analysis reveals that since the BTL housing was released onto the private market, neither Italians nor Americans are attracted to it; as a result it appears to suffer an extreme vacancy problem, as evidenced by the fieldwork. According to Hardt, now that the housing crisis has eased, Americans are not choosing to live in former BTL units because they want bigger apartments. The ease and camaraderie of the previous arrangement has disappeared as service members move away from the BTL units. Through social media, new families are actively discouraged from choosing the BTL units by other American families.

BTL...was Aviano's answer to not having base housing when the population of military increased dramatically about 12 years ago. Little concrete neighborhoods were built in the surrounding towns with the purpose of renting to military only. They were put back on the general market 2 years ago. They suck. We lived in one for almost two years before moving out into a privately owned home. The layout is poor, the maintenance was shabby, and the isolation away from Italy life wasn't great either.

The greatest travesty may be if the housing, vacant and unloved, is torn down. This would go against the USAF goals on sustainability and resource conservation, as well as be antithetical to Italian ideals of housing preservation.

Future research could closely examine the housing on the economy and the BTL housing using a case study method. Triangulation of the American stakeholder interviews with Italian stakeholder interviews, in particular the developers could shed light on the tradeoffs that were necessary in constructing the BTL housing. A future study could also ask: Given the results of BTL, what can be done now?

ACKNOWLEDGEMENTS

This research funded by a Research Fellowship from the University of Oregon Department of Architecture. Mike Toriello was essential in negotiating my permission and getting me on base. Tammy Hardt was prepared for our discussion and was extremely helpful.

REFERENCES

Notes: Interview with Tammy Hardt; May 20, 2014; Aviano Air Base
Notes: Interview with Mike Toriello; May 20, 2014; Aviano Air Base
Gillem, Mark L. 2007. *America town: Building the outposts of empire*. U of Minnesota Press.

Recycle as architectural cre-a[c]tive strategy

Moira Valeri¹

¹Yeditepe University, Istanbul, Turkey

ABSTRACT: In the last years, architects have learnt (again) to look at city and architecture as a material that can be recycled, re-evaluating its life cycles and mutations.

New tools, methods, and strategies try to give new meaning to what already exists in our cities, new life to what is discarded or abandoned, eliminating as much as possible the process of architectural waste to stop the phenomena of land consumption.

Recycling means to put back into circulation, reuse architectural waste materials, give them back a new value and meaning that they have lost because of economic or social reasons; basically it means transforming architectural waste into prominent figures. This is a practice that doesn't tend to immortalize the image of architectural space by attributing to it the value of the immutability- as it happens in restoration; on the contrary, the change is the value.

The way cities work today is the premise to recognize and reevaluate the amount of ruins architects should learn to deal with, developing the idea of 'contemporary archeology' to keep together the memory and the willingness of belonging to our *zeitgeist*.

Recycle is necessarily scale-less, contextual and convertible. Every place and every case involves a different project: there is no just one method to approach it, the idea itself of recycling is the common denominator for architects that want to keep a role in the transformation of cities that requires flexibility and a 'soft' approach rather than the use of stereotyped techniques and tools or traditional ways of thinking.

In this context, architects do not need to define a new architectural language or a manifesto; their architecture should be able to react positively to urban, social and cultural conditions and turn them into cre-a[c]tivity, recognizing the value and potential of discarded, neglected and ordinary buildings as an architectural resource – rather than as waste – that paves the way to a renewed project culture and face the challenges of the XXI century.

KEYWORDS: Recycle, Architecture, Environment, Community, Design

INTRODUCTION

In the last decades the role of architects and urban planners does not seem to be globally very clear because the idea of city that they developed in the last century, the idea of how to live in and the idea of public space and environment is also globally in crisis.

In the XX century, architectural research has focused on expressive language - starting from the big utopia of Modernism and its *tabula rasa* - in order to provide a recognizable and international style that shaped many of the buildings and part of cities that architects have to deal with today. There was a concern in defining a common architectural language, whether a building could be defined progressive, functionalist, rationalist, post-modern, deconstructionist, or minimalist. Apart from the utopias of the '60s that focused more on the scale of territory instead of the architectural one, all the researches of the XX century concentrated on finding an architectural expression that could lead the discipline towards the future, including the uncanny architectures that characterized the last years of the XX century on which Anthony Vidler focused in his book (Vidler 1994).

The traditional condition of the city is very much challenging today: the XXI century has started with other urgencies and different keywords are worldwide spread to find new and updated tools for the architectural project in order to face new challenges of the century: communities, recycling and environment show that architectural and urban studies should focus more on the relationships between space and society in order to be part of the fast growing or shrinking of cities that occurred in the last 30 years.

In the last years architects have been trying to react to the traditional idea of city on the one side putting (again) the autonomy of architecture as a discipline at the center of their own interest without keeping often into consideration the findings of other disciplines; on the other side trying to debate on the political and

environmental issues and inserting them into an architectural project through ecological technical details with the risk of impoverishment and subjection of architecture to other disciplines. To avoid both risks, architects are asked not to give up the creative nature of their commitment. On the contrary, they should transfer their political and environmental issues into a continuous expressive research, into a 'device' that represents their own *zeitgeist*.

1.0 THE CULTURE OF THE ABANDONMENT

The urban, cultural and economic changes of the last years have left many buildings obsolete, not anymore suitable for the functional program they were built for. Even though the aesthetic of the ruins has always fascinated architects - inspiring a vast body of literature, texts and essays on the issue of memory and nostalgia of passing time - the abandoned and underused buildings, recent ruins with no role anymore, have a negative effect on many aspects of the city and its public domain.

The global financial crisis represents one of the main reasons of this short circuit; at the same time this seems to be an opportunity to re-define the methods and tools architects can develop to keep up their role in the society, re-evaluating what already exists not just as a copy of the original building, as it happens in restoration that aims to 'embalm' it, but as an opportunity for the architectural and urban studies to look and move forward. As Rem Koolhaas has stated

we then looked at the history of preservation in terms of what was being preserved, and it started logically enough with ancient monuments, then religious buildings, etc. Later, structures with more and more (and also less and less) sacred substance and more and more sociological substance were preserved, to the point that we now preserve concentration camps, department stores, factories, and amusement rides. In other words, everything we inhabit is potentially susceptible to preservation. [...] We are living in an incredibly exciting and slightly absurd moment, namely that preservation is overtaking us. (Koolhaas 2014,15)

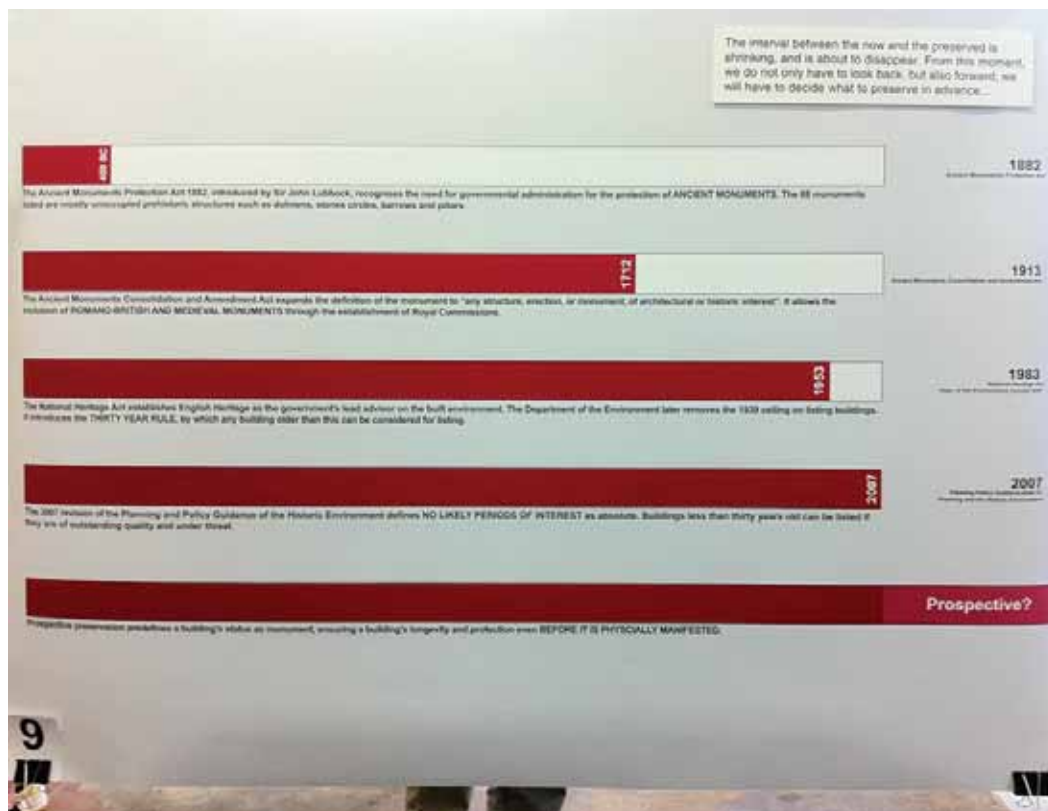

Figure 1: Time by time, each new preservation law has shifted the date of preservation for architecture closer to the present, in *Cronocaos*, OMA's exhibition at the 12th International Architecture Exhibition La Biennale di Venezia, 2010. Source: (Author 2010)

Sometimes it is more convenient to tear them down, sometimes it is less expensive to reuse and bring them to life, sometimes it is more culturally engaged to keep the memory and try to experiment, diversify and revivify not only existing buildings but also entire obsolete areas or disused infrastructures.

They all represent an important social, cultural and above all architectural resource, not waste: as a result, a new constructive and positive approach has to be taken up toward the existing stock.

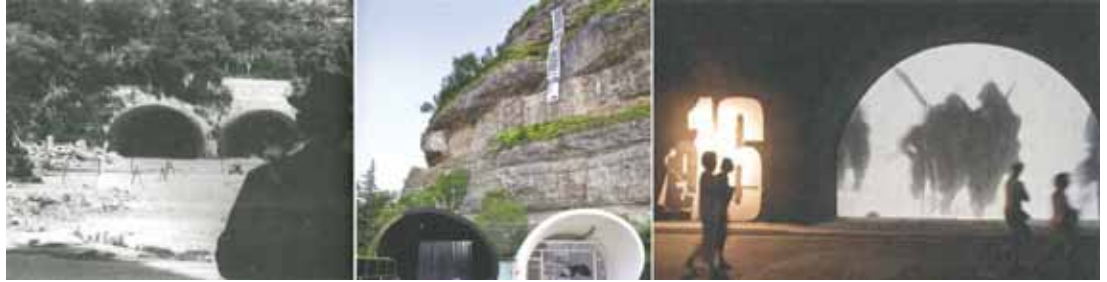

Figure 2: Elisabetta Terragni, Jeffrey T. Schnapp, Filmwork, Gruppe Gut, the Tunnels of Trento, Italy, 2009. Transformation of a disused urban infrastructure - two 300 meters tunnels - into galleries. Source: (Ciorra, Marini 2012, 28-30)

There is still a crucial production of uncanny buildings by architects - that get the attention of public interest - whose architectures somehow remind us all the heroism of the Modernism founded on the idea of *tabula rasa*; at the same time another architectural strategy is trying to focus on minimum intervention or unvolumetric architecture¹.

The issue of recycling is actually far from new: reuse, rehabilitation, reconversion exist from long time but it has started to be at the center of architectural and urban debate only recently².

This is the deeper meaning of recycle: re-building instead of building, parasiting the existing ordinary buildings³, giving them a new program and meaning through the construction of scenarios rooted in scientific hypothesis that on the one hand can overcome both the limits and weaknesses of current practices related to recovering or modifying existing buildings through pure technical interventions and on the other hand can accept the fast economic shifts and growth of cities without losing the opportunity to define the intrinsic values of architecture, city, landscape, and above all environmental sustainability, nowadays indispensable and crucial in every project.



Figure 3: Naumann Architektur, Pfalz, Germany 2008. The recycle of a stable for pigs (*saustall*) to a showroom: *s(ch)austall*. Awarded the 2005 Architectural Review Award for Emerging Architecture. Source: (Ciorra, Marini 2012, 156-158)

In the field of monument preservation, the value of the existing architecture and the priority of conservation are already a given. Society agrees on the value of the historic building that stands in stark contrast to the value placed on the "ordinary" buildings. Even such buildings, which are all often dismissed as worthless, have potential and qualities that can be brought to the fore through qualified and creative remodeling. (Petzet, Heimeyer 2012, 10-11)

It becomes urgent to think how to avoid the construction of new buildings and the large loss of land that threatens our environment and how improve the *status* of existing stock without using a mimic attitude; on the contrary, giving a new meaning to the abandoned materials applying new strategies of methodical organization.

2.0 THE RE-EVALUATION OF WASTE AS RESOURCE

The idea of city and architecture has changed a lot compared to the sense of urbanity which was commonly shared by the society until almost the end of the XX century. Today architecture as an academic and professional discipline is rooted not only in the monolithic spatial order architects used to know but also and above all in material and immaterial networks that push the discipline itself to search and find also virtuous alliance with other ones as art, sociology, cinema, photography, etc.



Figure 4: Music on Bones. In the 60's in Russia it was illegal to import Western music. The solution was homemade records pressed on exposed X-Rays called bone music. Source⁴



Figure 5: Zbig Rybczynski, "Steps", 1987. The audiovisual language is disassembled and reassembled by the movie director recycling the sequence of the steps of "The Battleship Potemkin" by Sergei Ejzeštejn with material shot by the Polish director. The history of the coded language of film is expanded using the new tools available to the modern filmmaker, linking past with present. Source: (Ciorra, Marini 2012, 16-17)

In the last ten years, new urban and architectural regulations in some European countries and some exhibitions hosted by important cultural institutions highlighted the idea that some architects have developed and shared about the city: the necessity that it should grow on itself rather than expanding beyond its current physical limits.

In 2004, in France two important facts paved the way to a new approach towards the existing stock. On the one hand the State expressed the willingness to change the image of the city through a significant public program that presupposed the demolition and reconstruction of towers from the 1960s and 1970s. On the other hand the lack of public housing pointed out the increasing necessity to construct rapidly new buildings. In this context, the Ministère de la Culture et de la Communication, Direction de l'Architecture et du Patrimoine appointed Druot, Lacaton & Vassal that through a study - PLUS Les grands ensembles de logements Territoires d'exception - remarked that the demolition was not necessary and showed how the transformation of the existing towers could be suitable for the needs of the residents from both the aesthetic and economic point of view.

In 2006 at the International Architecture Exhibition La Biennale di Venezia, 'Cities, Architecture and Society', the curator Richard Burdett used sixteen case study-metropolises to underline the urgency of appropriate urban answers to the problem of demographic pressure. In this Biennale two shows pointed out in a complementary way the urgency for a recycle approach of the existing stock.

The first one is a research project best known as 'Shrinking Cities', edited by Philipp Oswalt.

It seems at first to simply point to a phenomenon: the decline of urban population and economic activities in certain cities. [...] There is also growth in the process of shrinkage: it results in excess spaces, buildings, and obsolete properties (Oswalt 2006, 12).

The second one is the German Pavilion, 'The Convertible City', that supports and encourages the reuse of existing buildings triggered by the new urban regulation that limit the construction from scratch; an urban policy that aims to limit the land take - promoted first in 1998 by the then Federal Environment Minister Angela Merkel⁵. The new legislation has generated an architectural debate focusing on underused building stock to solve the problem of land use. Most of the existing buildings do not belong to extraordinary history but rather they represent 'dead bodies' in the city life. The exhibition shows many projects by architects, landscape architects, urban planners and artists focusing on new scenarios for architecture through a new flexible approach to the problem.

In 2009 the former French President Nicolas Sarkozy launched 'Le Grand Paris', an urban and architectural consultation for a new global plan for the Paris metropolitan region. The ten selected architectural teams worked on the theme of 'building the city on the city', thinking on how to better use the land that is already built-up and keeping the limit of the expansion of the built environment. From the urban and architectural point of view, the Grand Paris marked an important step in the critic towards the government policy of recent

years that has aimed to change the city by demolishing and rebuilding, or developing new land. On the contrary, the ten teams provided scenarios in which interstitial and underused areas - in particular those ones near railway tracks or along the waterways - were taken into consideration and densifying, recycling, repurposing were the main actions.

In 2010, again at the International Architecture Exhibition La Biennale di Venezia, the Dutch Pavilion, 'Vacant NL', displayed the potential for innovation offered by vacancy and the value of vacancies as a future opportunity of urban transformation. In the booklet of the exhibition Saskia van Stein states

Not only the transformation of the use and function of a space; the time has come to think more intelligently about the spatial consequences of our actions. But also the transformation of concepts and values. We have to take a new understanding of our economy into consideration, a new way of thinking by complementing hard cash with 'softer' values⁶.

It implies a change in tools, methods, role and attitude that architects should take into consideration when they debate on architecture and urban development in order to catch the structural meaning of vacancy, above all in some areas and countries.

In the same year another exhibition at MoMa in New York 'Small Scale, Big Change. New Architecture of Social Engagement', showed eleven projects that reveal the necessity for architecture of the XXI century of being not only less 'spectacular' but above all more socially engaged in order to find, at every scale of the project, a positive synergy to provide the best program, aesthetics values, and resource optimization: architects not only as designers of buildings but also as moderators of change.



Figure 7-8: Frédéric Druot, Anne Lacaton, and Jean Philippe Vassal, Transformation of Tour Bois-le-Prêtre, Paris, France, 2006–11 displayed at 'Small Scale, Big Change. New Architecture of Social Engagement' exhibition. New loggias, built as self-supporting structure, are added on three sides of the building. The transformation of the residential tower shows the legitimacy of the thesis architects disclosed in their study PLUS in 2004. Source: (Ciorra, Marini 2012, 26-27)

In 2011, the exhibition 'Recycle. Strategies for Architecture, City and Planet' at MAXXI Museum in Rome marked a major step in the timeline of the issue. The curator starts off from the idea of recycling as a creative and innovative 'device' in a transversal and interdisciplinary way; not just simply reuse of disused buildings but a strategy for architecture to face the challenges of the XXI century. The exhibition - that includes many works also by artists, photographers, media producers – points out that

the recycling strategy would appear to be an approach that allows us to keep together memory and radical innovation, a sort of small socio-expressive utopia that can guide us in a reconstruction of territories and theories at the same time (Ciorra, Marini 2012, 25).

The topic catches on and in 2012 two other exhibitions coincide. The first one is set again by Germany in its Pavilion at the International Architecture Exhibition La Biennale di Venezia, 'Reduce, Reuse, Recycle. Architecture as Resource'. The interest in what already exists – above all the ordinary buildings - and how to revivify them is once again the *fil rouge* that keeps together many projects displayed in the show.

There is a surplus of architecture. Downsizing and minimizing have become key planning issues, and even in areas with growth, the issue at hand is not about tabula rasa and new construction, but about regeneration, conversion, aggregation, and extension - not only of individual buildings, but of the urban fabric as a whole. How to deal with existing architecture is both culturally and economically crucial to our future; ambitious environmental targets can only be achieved by improving what is already there and by renewing existing infrastructures. (Petzet, Heimeyer 2012, 9)



Figure 9: KARO Architekten, Open-air Library, Magdeburg, Germany, 2008-2009.

The open air library was established just for two days in 2005 in an abandoned industrial district using beer crates as building material (left). The initiative evolved until the opening of a civic library in the same site in 2009 (center). The façade elements come from a demolished department store (right). It is an example of both relying on low-cost approach to make big project and building with residents that take the ownership of the space. 2011 Brit Insurance Design Award, Category Architecture. Source: (Ciorra, Marini 2012, 182-183)

The second one in Paris in the Pavilion de l'Arsenal, 'Re.architecture, Re.cycle, Re.use, Re.invest, Re.build' shows thirty projects by fifteen invited European teams that have been working both on small interventions and urban strategies. In both cases leftover or in transition spaces and territories are used as an opportunity to generate social activities and a dynamic and attentive approach towards the contemporary city and architecture.



Figure 10: The main exhibitions on the theme of recycle, from left: the German Pavilion, *Convertible City*, Architecture Biennale in Venice, 2006; the Dutch Pavilion, *Vacant NL*, Architecture Biennale in Venice, 2010; *Recycle. Strategies for Architecture, City and Planet*, MAXXI Museum, Rome, 2011; the German Pavilion, *Reduce, Reuse, Recycle*, Architecture Biennale in Venice, 2012; *Re.architecture, Re.cycle, Re.use, Re.invest, Re.build*, the Pavilion de l'Arsenal, Paris, 2012. Source: (Author 2012)

3.0 RECYCLE AS AN ARCHITECTURAL CRE-A[C]TIVE STRATEGY

In the last years, architects have learnt (again) to look at city and architecture as a material that can be recycled, re-evaluating their life cycles and mutations. New tools, methods, and strategies try to give new meaning to what already exists in our cities, new life to what is discarded or abandoned, eliminating as much as possible the process of architectural waste to stop the phenomena of land consumption.

Recycling means to put back into circulation, reuse architectural waste materials, give them back a new value and meaning that they have lost because of economic or social reasons; basically it means transforming architectural waste into prominent figures. This is a practice that doesn't tend to immortalize the image of architectural space by attributing to it the value of the immutability - as it happens in restoration; on the contrary, the change is the value.

The scheduled duration of the building - in which the project aims to define the construction process as well as its management until the disposal and recycling - causes an epistemological leap both in the theory and

practice of architecture because from the beginning the project takes into consideration the subject of the end of life (of materials, components, the building itself): not stability and persistence over time but 'positive weakness' and change.

The theoretical value of recycling is in the shift of the idea of architecture itself: architecture is not only a synonym of stability, a building for eternity, or a project as an authorial decision anymore but it is constantly changing, a temporary program and it involves designing as a process shared by many. In this way it is possible to build an urban environment that is the portrait of the society that lives there and at that time. This is an open way to catch the speed of contemporary changes or needs of the society in the post industrialized era. In this context, it is important to distinguish the real ecological urgency from the 'greenwashing' market-oriented strategies and to understand what sustainability really means as architects in order to transform ecological issues into architecture without losing the potential of design, and at the same time recognizing the landscape as

an important part of the quality of life for people everywhere: in urban areas and in the countryside, in degraded areas as well as in areas of high quality, in areas recognized as being of outstanding beauty as well as everyday areas

as stated in Preamble of the European Landscape Convention. The way cities work today – mainly under economic and political forces that architects cannot manage themselves – is the premise to recognize and reevaluate the amount of ruins architects should learn to deal with, developing the idea of 'contemporary archeology' to keep together at the same time the memory and the willingness of belonging to our *zeitgeist*. Recycle is necessarily scaleless, contextual and convertible. Every place and every case involves a different project: there is no just one method to approach it, the idea itself of recycling is the common denominator for architects that want to keep a role in the transformation of cities that requires flexibility and a 'soft' approach rather than the use of stereotyped techniques and tools or traditional ways of thinking that do not fit well in the fast-changing contemporary world.

In this context, architects do not need to define a new architectural language or a manifesto; their architecture should be able to react positively to urban, social and cultural conditions and turn them into creat[iv]ity, recognizing the value and potential of discarded, neglected, and ordinary buildings as an architectural resource – rather than as waste - that paves the way to a renewed project culture and face the challenges of the XXI century.

REFERENCES

- AA.VV., 2010. *Maintaining Biodiversity By Protecting The Environment*, Dessau: Federal Environment Agency (AAVV 2010).
- Aymonino, A., and ., Mosco, V.P. 2006. *Contemporary Public Space. Un-volumetric Architecture*. Milan: Skira (Aymonino, Mosco 2006).
- Ciorra, P., and Marini, S. 2012. *Recycle. Strategies for Architecture, City and Planet*. Milan: Electa (Ciorra, Marini 2012).
- Koolhaas, R., 2014. *Preservation is overtaking us*. New York: GSAPP Books (Koolhaas 2014).
- Marini, S., 2009. *Architettura parassita. Strategie di riciclaggio per la città*, Macerata: Quodlibet (Marini 2009).
- Oswalt, P., 2006. *Shrinking Cities. Volume 1*, Ostfildern-Rui: Hatje Cantz (Oswalt 2006).
- Petzet M., Heimeyer F., ed. 2012. *Reduce, Reuse, Recycle. Architecture as Resource*, catalogue of the German Pavilion at 13th International Architecture Exhibition La Biennale di Venezia 2012. (Petzet, Heimeyer 2012).
- Rietveld R., Rietveld E., Bey J., Mackic A., Visser B., van de Wiel E., Zoeteman M., 2014. *Vacancy Studies. Experiments and Strategic Interventions in Architecture*, Rotterdam: Nai010 (Rietveld et al. 2014).
- Vidler, A., 1994. *The Architectural Uncanny. Essays in the Modern Unhomely*. MIT Press. (Vidler 1994).

ENDNOTES

- ¹ Aymonino, Aldo, and ., Mosco, Valerio Paolo. *Contemporary Public Space. Un-volumetric Architecture*. Milan: Skira, 2006.
- ² Ferlenga Alberto, "Recycling and Corrections", in *Recycle. Strategies for Architecture, City and Planet*, ed. Ciorra Pippo, and Marini Sara, Milan: Electa, 2012.
- ³ Marini, Sara, *Architettura parassita. Strategie di riciclaggio per la città*, Macerata: Quodlibet, 2009.
- ⁴ "How Soviet Hipsters Saved Rock 'N' Roll With X-Ray Records", last modified June 23, 2014, <http://www.fastcodesign.com/3032206/how-soviet-hipsters-saved-rock-n-roll-with-x-ray-records.html>
- ⁵ AA.VV., *Maintaining Biodiversity By Protecting The Environment*, Dessau: Federal Environment Agency (UBA), 2010.
- ⁶ Van Stein S., "Temporality at Use", in *Vacant NL. Where Architecture Meets Ideas*, the booklet of the Dutch Pavilion at the International Architecture Exhibition La Biennale di Venezia, 2010. The research project has been carried on and published in Rietveld R., Rietveld E., Bey J., Mackic A., Visser B., van de Wiel E., Zoeteman M., *Vacancy Studies. Experiments and Strategic Interventions in Architecture*, Rotterdam: Nai010, 2014.

Sensory informed design: Human processes and emerging sensory tools

Diana Nicholas¹, James E. Connell¹, Jennifer Plumb¹

¹Drexel University, Philadelphia, PA

ABSTRACT: The paper examines the process of designing a Mobile Autism Assessment Unit, and the consideration of the development of a Post Occupancy for use in further design of products and spaces for people with sensory processing issues. Emergent processes are considered as a mode for examining user metrics in a space for people with sensory issues. The possibilities of evaluation of human comfort through study are also examined.

KEYWORDS: Sensory Design, Autism, Post Occupancy, Informed Design

INTRODUCTION

In building for change, the question of framing a problem correctly is often the path to realization. As designers, we often find ourselves in the role of question makers, and continually the answers come from the process of information gathering and research. (Dickenson et al 2009) In design, the problem to be solved is first framed by need, and increasingly the needs of specialized clients require novel research and outcomes. This work will study the multidisciplinary nature of the well-framed question through the ongoing speculative development of an evidence-based process. In the process this paper will lay out a possible initial method for developing a metric that will create quantifiable and adjustable relationships between humans and their material environment in the design of interior environments. Using the van project as a basis as well as the examination of several areas of architectural research, the hope is to lay out a path of the development of such a metric. This metric creates the base to design a digital modelling tool via which it will be possible to measure material scenarios for their relative human comfort factors and their spatial and sensory outcomes for various populations with special needs. In considering the possibilities for analysing such an approach to interior space and comfort, the author hopes to understand how three areas of study can overlap to create possibilities for tool development. These three areas are the study of sensory disorders, computational design tools and the current ways we look at spatial comfort. In order to create a novel metric these three areas will be examined to lay out initial ways that they may contain affinities to create a system for analysis and understanding of space based on human interaction, use and reaction. This work contains process speculation which is distinct from the actual future assessments that may take place to fulfil the processes examined here.

1.0 MOBILE_REACH VAN

1.1. Design process

In the summer of 2012, The A.J. Drexel Autism Institute and a multidisciplinary group of students at Drexel University collaborated on a design to create a mobile clinic for the use of the Institute. The first mobile assessment unit in a heavily populated urban area and one of very few mobile clinics for autism in the U.S., this clinic will work to reach underserved populations in this urban area. (A.J. Drexel Autism Institute Website, 2013) The design was developed through a six-week studio course, in which four multidisciplinary teams of students developed designs for the project. The program included designing the interior and exterior of the mobile unit.

The process included advisers and researchers from the field as well as parents with children on the spectrum. The students created visual research boards to document their findings and information gathering in relationship to designing spaces for children on the spectrum. The initial program was laid out as an introductory document for the students into the needs of this specific user group:

Following are suggested specifications for the mobile assessment units:

Interior:

Clinical assessments for children with autism require one-to-one interaction. The interior of the assessment (rear) area of the unit should optimally accommodate this need for space and movement given the constraints and possibilities of different family members attending along with the clinical staff.

Individuals with autism often have specific sensory needs. Dimmable lights, neutral tones and textures, and minimization of outside sounds are ideal. Some child-friendliness to the theme is desirable. Needs to accommodate an assessor, one parent and a child. Should be movable seating available for all in the assessment space. Seating should be quickly stow-able, so that the space can be quickly cleared for floor play. Perhaps multiple sized seats should be available or loadable into the van based on what is known about the participants being seen that day.

A convertible table with room for adjustable heights and parent or guardian is needed.

Two-way viewing form the front seat area of the van for electronic and safety control is necessary.

"Lab" area. A designated area for a small refrigerator for temporary transport of collected bio-samples and a small flat work surface where a portable centrifuge could be run (this would require a power outlet). Stowage for the centrifuge would also be necessary although this portion of the unit would not be used when participants are in the vehicle for assessment.

Storage. There should be closable, lockable storage for laptop, notes and files. Also should be storage to accommodate a range of toys/stimuli needed for assessment, although these toys will be loaded on and off the vehicle as needed. For example, one commonly used autism assessment (the Autism Diagnostic Observation Schedule or ADOS) includes a stimuli kit that comes in a large plastic tub (950cmx570cmx505cm). There should be additional storage for other testing equipment, including a portable eye tracker (approximately 50cmx70cmx25cm) and other equipment (potentially up to 100cmx150cmx50cm). There should also be some additional flex storage.

Exterior:

Mobile assessment units will have a flexible exterior design flexible exterior design. Particularly for research studies, any mention of "autism" will need to be removable to protect the health information of participant individuals and families. Yet for other occasions, it would be helpful to emphasize "autism."

The mobile assessment units should be approachable if parked in a community and have the ability to be branded in multiple languages.

Units must have a safe, navigable, inviting entry for participants. Because the space is somewhat smaller and more confining, it is important that the entry not be intimidating.

Paraphrased from the project brief provided by the client

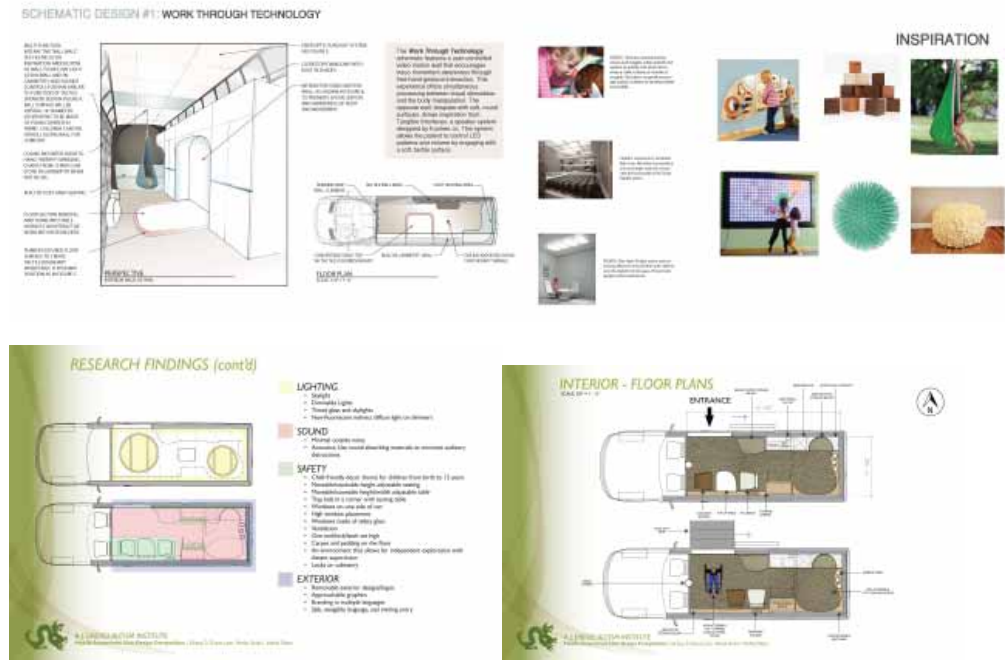

Figure 1: In progress visual research boards from the course Source: (Author 2014)

The students presented their initial design findings to the experts and received feedback in the form of lists of issues that could be better addressed. The students soon discovered the needs of these users had distinct areas that were important in terms of security, calming, interactive stimulation and interface. In some ways the van was thought to be an excellent space for such interactions as it is enclosed and controlled from a spatial standpoint. Documented in the table below, these suggestions created a very specific arena in which the students' designs could operate in terms of the users' needs.

Table 1: Autism expert Suggestions Source: (Author's Class Notes 2014)

<p>"Would be great if the table for testing could not only adjust in height and width, but also have a corner to "trap" kids in one section of the van. My idea would be to have the table collapse and stored in the floor of the van but that might not be feasible Windows should definitely be put in, but they should be at the highest point possible on the side of the van so as to not distract testing. Not only will this detract from the kid looking out the window, but would also help others from looking in and being distracting"</p>
<p>"Interior walls of the van should be neutral and not distracting to the eye."</p>
<p>"Important to carpet and pad the interior floor, because participant may collapse to the floor or tantrum"</p>
<p>"Having just one exit, with the lock set high, would be helpful to diminish elopement"</p>
<p>"Skylight would be great"</p>



Figure 2: Chosen Scheme Source: (Author 2014)



Figure 3: Chosen Scheme; team presenting to local experts Source: (Author 2014)



Figure 4: Final Van Source: (left, Courtesy A.J. Drexel Autism Institute; Right Author 2014)

Students worked to address the concerns and the discussions in the studio centered on the ways in which the users' needs differed from the needs of users in different situations. At the conclusion of the term one option was chosen for development. The chosen option represented the hopes of the Institutes staff and the needs of the users most successfully. At that point, a team including faculty collaborated to create the final design with the institute. This charrette lasted several months and was a way to compile the findings of the student teams. With the Van completed, this team is now compiling an interdisciplinary research study of the mobile assessment process in order to understand the particulars of the space. The project and the further research outcomes will be used to frame the question: is mobile assessment successful, and if so, why? In the study, Research questions will be asked pertaining to both the use of the space and the increased access to underserved populations. The project will examine the questions, which frame this area for further work based in the research created by the multidisciplinary team and for future projects. In tracing and re-framing the process behind the in-progress research project, the author hopes to draw out the ways that such projects and processes can create ongoing multidisciplinary problem solving. The study will include referencing video of interactions to observe and map in space the interaction between assessor, family and child. In addition the possibility of eye tracking scanning tools have been considered in order to study the level of engagement on the part of the child in the assessment.

1.2. Post occupancy

In designing a post-occupancy study, the team has examined literature related to human comfort metrics. These include resources on architectural post occupancy review. In reviewing these resources it has become evident that human comfort is often measured in the most general ways that do not always apply for special populations. (Leaman, 2003) The ongoing project will examine the questions, which frame the area of post occupancy in a van for future projects based in this research created by the multidisciplinary team. Currently research approaches developed by the team in-group meetings include the below:

Table 2: Question and Topic inventory: (Author's Meeting Notes 2014)

TYPES OF ACTIVITIES AND USES	TYPES OF INTERACTIONS AND QUESTIONS	TYPES OF USERS
OUTPATIENT THERAPY ON WHEELS VAN THERAPY BRIEFER FUNCTIONAL ANALYSIS	RANGE OF POSSIBLE WAYS TO USE ASK THEM ABOUT HOW THEY FEEL	KIDS PARENTS
FUNCTION BASED ANALYSIS NEGATIVE ASSOCIATIONS MULTIPLE OPTIONS FOR ASSESSMENT WHAT IS POTENTIAL IN VAN? GENERAL SCHOOL DISTRICT PROVIDED THERAPY COST BENEFIT OBSERVATIONAL DATA UNDERSTANDING WHAT IS ON OTHER? UNDERSERVED POPULATIONS - DOES IT ADDRESS? WHAT HAPPENS AFTER EVENTS?	FAMILIAR VS NEW ACCESS TO SERVICES? NEGATIVE ASSOCIATIONS BARRIERS? LEGAL STATUS? LANGUAGE? WHAT DRAWS PEOPLE? FOLLOW UP QUESTIONS? PLAY IN ADOS MAY BE DIFFICULT 20-30 ITEM QUESTIONS ABOUT THE VAN FUNCTIONALITY RANDOMIZE VAN VS. SPACE HOW USEFUL? MEANING OF ASSESSMENT	COMMUNITY LEADER
AVERSIVE OR CONDUCIVE DISCRETE TRAINING RESOURCE CENTER?	WOULD THEY GO TO FOLLOW UP?	
ASSESSMENTS: JOINT ATTENTION EYE CONTACT		

Simply put, the team will study how the van is used, and how this use could be improved in future iterations. The ongoing study will include both clinical information and design based spatial mapping information. The goal is to understand the challenges found in the assessment process due to the space inside the van, and then to design and implement solutions to those challenges. The team will look to the assessment interaction to understand the relative success or challenge of the space. Factors such as disruption, hyperactivity, anxiety or aggression could be rated and observed; in addition, the use of the space will be observed through diagrammatic mapping of the space. These two sets of observations will then be correlated in order to create a better understanding of the issues at hand. In specific behavior assessment is something that has been identified as a possibly difficult thing to measure due to the subjective nature of this. Recent development in the study instrument has created the opportunity for asking the family members for feedback on the child's mood during the interaction as a way of balancing the information gathered from the assessor. The line between the clinical study and the study of the space has been a much-discussed topic for the team. Non-mobile assessments will be examined in the same manner in order to create a baseline for understanding how the interaction occurs in space. The research is planned to occur both in the field and in the usual non-mobile assessment environment and will piggyback onto a clinical assessment that is in the process of being planned. Research will be culled from the documentation of ongoing assessments and also the physical measuring and mapping of space. Mapping as a research tool here will include the drawing and representing the space and plotting of the movement of inhabitants repeatedly in order to track the manner that the interaction takes place physically. The effect being mobile has on the assessment process from a physical and behavior standpoint is a main area of interest in this study. For example, the study will undertake to understand if there are more disruptions involved in the mobile study, and if these disruptions can be attributed to something in the mobile environment.

The chief assessment process employed by the Institute in the Mobile Unit is the Autism Diagnostic Observation Schedule 2 (ADOS-2). This is a 30-60 minute interaction between the researcher and the child, and holds within it many challenges for studying and understanding the child's behaviors. (http://www.autism.net.au/Autism_diagnosis.htm; 2014) We are hoping to draw conclusions that will lead to the development of solutions that will be both space-based, and product-based. Space based solutions are different adjustments that might be made to spaces as assessments take place in order to create less disruptions and anxiety to the subjects. For example, ceiling heights could be adjusted to better accommodate the perceptions of subjects and give them focus during the assessment. Product based solutions are evidence based ideas that arise through observations of how to improve the space. Product based solutions could be translational research that could lead to bringing products to market for use by other units doing assessments for instance an assessment chair, or screen hat is designed around the findings from this study. Because of the proscriptive nature for the interaction both physically and in terms for time, the assessment interaction is uniquely positioned to reveal possibilities for user comfort and calming. The research will also determine the types of adjustments to spaces for assessment that would be optimal for the subjects. In addition the research will be used to design and prototype possible product add-ons to similar spaces that could be implemented in other situations that are not designed for assessment to take place.

Primary research questions for the Van have mostly to do with the *genus loci* of the assessments occurring. Does mobile space augment or diminish the assessment process? This will be determined through data related to subject behaviors. What are the physical challenges that are created in the spaces that emerge in assessing children on the autism spectrum? How does the mobile setting increase or decrease these challenges? Is it possible to design and produce features that mitigate these interactive challenges in the space?

2.0 EMERGING CONSIDERATIONS: ASSESSMENT AND METRICS

2.1. Design for autism

The information on user metrics for users with special needs is scarce, other than temperature control and air quality not much is available. “Sensory Design Theory is based on the concept of the sensory environment as a major role player in the process of perception and behavior development. Much like the concept of the “sensory diet” (Willbarger & Willbarger, 1991 and Anderson, 1998), this environment is considered something that can be manipulated to the benefit of the autistic user.” Mostafa, M. (2008)

In the article: *ARCHITECTURE FOR AUTISM: Autism ASPECTSS™ in School Design*, M Mostafa lays out the two ways that we can design for people with sensory disorders including those on the Autism spectrum. The first is “Neuro-Typical” design in which the user must adapt their senses to the world around them; being exposed to the more typical kind of environment as a process of acclimating. (Mostafa 2014) In addition, Mostafa describes Sensory Environmental design as giving the user the opportunity to adjust their environment in order to be comfortable. The chart of sensory design issues developed in Mostafa’s article are the closest user impact research found on the sensory impact of spatial issues for this population. This is a viewpoint in which the issues of ASD are considered through a design influences lens. In fact, in the table Mostafa qualifies the findings of her understanding of sensory issues in design through the design requirements laid out in *From Space and Order* by Frances D.K. Ching, including structure balance quality and dynamic. Each of these are broken down into the Ching spatial descriptors of closure proportion, scale focus symmetry rhythm harmony balance etc. (Ching, 1996; Mostafa, 2014) by mapping the relationship between the “subjective” topics and user sensitivities, this author is able to create a design based rating of spaces. From this work, we can extract the following: that zoning the space into sensory zones based on the level of interference from the environment can lead to successful design typologies for users with ASD. In addition, from Mostafa’s work it becomes clear that the priority in terms of designing for those with sensory issues is auditory, followed by the sequencing of spaces and visual/tactile. According to this body of work, the priorities for designing for those with autism spectrum disorder (ASD) are as follows:

1. Acoustics: Children with ASD respond positively to sound controlled environments.
2. Spatial Sequencing: That spatial arrangement should have a logical order, that routine be re-enforced through space.
3. Escape Space: Provide sensory respite to users so that they cannot get overwhelmed.
4. Compartmentalization: Keep sensory stimuli separated and to a minimum.
5. Transition Zones: Overt zoning of transitions between the zones
6. Sensory Zoning: Zoning based on the relative amount of stimulus a space contains as opposed to the usual functional zoning that occurs in spaces.
7. Safety: Highly important for people with special needs. (Mostafa 2014).

2.2. Measuring space for the senses

As stated above most of the building assessment currently undertaken has not measured the affect, or effect of the built environment of the senses as closely as one might hope for a project such as this. (Leaman 2003) Mostafa’s system of design leads us to ask what would a system of assessment look like in order to measure for the success of a design for those with these issues. Current literature includes the BUS Occupant Survey (<http://www.busmethodology.org.uk/>, 2014) this assessment directly evaluates the occupants reaction to the space, but the metric is subjective. Perhaps a more objective mode could be deployed through a layered mapping that plots the user’s satisfaction against sensory data that is collected in the space?

“Emergence is a consolidation of a profound change in knowledge and materialization that has made significant changes to science and technology, and to the way in which we think of architecture and the way we produce it. Emergence provides an explanation of how natural systems have evolved and maintained themselves and a set of models and processes for the design and fabrication of architectural forms that exhibit complex” (Menges 2014)

Several sensory sites discuss the sensitivities inherent not just those with ASD. Elements of sensitivity to sound would most definitely need to be measured, “The sensory system is made up of seven areas, tactile, olfactory, auditory, visual, taste, vestibular, and proprioception (sense of body/joint movement and knowing where the body is in space).” (<http://southpawenterprises.com/content/signsofspd.asp>, 2014) How to measure the response of

users on that level without the use of sensors, may be found through the processes associated with emergent and parametric design. These processes involve the layering of systems for generation of unique models in ways that follow the inherent flow of various structures based on natural structures, at a molecular level. The author asks the question, would it be possible to re-structure the analysis of a space based on a subtler set of criteria that might be emergent in nature? The physicist Jessica Green has done this in her work with the study of the air handling qualities within the biome of a building. Autodesk is creating tools that allow for environmental and biome tracking, this user proposed a peon based tool for the tracking of comfort. (Markoff, 2013) Emergence requires that we look to complex structures to create new structures for design. The author sees the evolution of data, emergence and human behavior as a true opportunity to examine the multifaceted needs of a burgeoning population. This kind of compound mapping would seem to be necessary in order to understand the nature of assessing spaces for the needs of such complexly inhibited users. The final question of this paper exists as a snapshot of the developing process traced in the van project through the development of the speculative study and into the coding and creation of data models as a next step. From design, to tracking users, to creating parametric models-the development of a visually programmed universal tool could create a way to test the success of spatial interventions.

CONCLUSION

The design and construction of spaces for children with sensory processing issues will become more prevalent as the percentage of our society with these issues continues to increase. (Newschaffer et al, 2009) The van project is one example of this type of space, and it is a concentrated example due to the homogeneity of the intended population. In developing the research for the van, the ideas of what a true tool must touch on have emerged, and these include measurements for user comfort that more closely address these sensory issues. The cross-section of our society with some concern in this regard is growing, and the best way to address the needs of children within many different ranges; through both treatment and support in everyday life makes this an extremely relevant issue for the design of the built environment. This paper lays out options for both data collection and data mapping to assess how to create comfortable spaces for people with these requirements in everyday life and to posit a path for assessing more closely the possible responses users might have to these types of specific situations in the built environment.

ACKNOWLEDGEMENTS

The authors would like to thank: A.J. Drexel Autism Institute: Craig Newschaffer, PhD AI Founder; Connor Kerns, PhD; Lindsay Shea, MS; Students: Arzayus, Blanca; Bakhit, Hattan; Leff, Fay E. ; McMenamin, Maureen P. ; Prutzman, Shannon N.; Siriani, Alexis; Takeo, Yoshie; Young, Lauren M.; Heucke, Stephanie L. ; Lam, Grace; McLean, Ilana A. ; Vargas, Miguel A. ; Webb, Christine C. Student researcher: Jessica Neilsen

REFERENCES

- Anderson, J.M. 1998. *Sensory Motor Issues in Autism: Therapy Skill Builders*. Texas, USA: The Psychological Corporation.
- Bordass B., A. Leaman & P.Brager, G. S., & Baker, L. 2009. *Occupant satisfaction in mixed-mode buildings*. *Building Research & Information*, 37(4), 369-380.
- Ching, F.D.K. 1996. *Architecture: Form, Space and Order*. New York, NY: John Wiley & Sons.
- Dickinson, Joan I.; Marsden, John. 2009. *Informing Design*. London: Fairchild Books
- Flanagan, Joanne. 2009. *Sensory processing disorder*. *Pediatric News* Aug. 2009: 22. Academic OneFile. 2 Dec. 2014.
- Gandy, Samuel E. 2004. "Snoezelen Rooms May Offer Benefits for Those With Dementia." By Alzinfo.org. Web. Dec. 2014.
- Kern, Janet. 2007. *Sensory Correlations in Autism*. Autism, Sage Publications, Vol. 11(2), p. 123.
- Knippel, Jim. 2004. "Better Living Through Snoezelen at Beth Israel New York." New York: New York Press.
- Kolarevic, Branko and Klinger, Kevin ed; 2008. "Manufacturing Material Effects Rethinking Design and Making in Architecture". Routledge New York and London. Pp. 37-39
- Kottas, Dimitris. 2010. "Contemporary Digital Architecture design and Techniques"; Links Press; BarcelonaP.12
- Leaman A. 2003. Post-occupancy Evaluation paper prepared for Gaia Research CPD Seminars on Sustainable Construction, January
- Leaman A. 2004. User Needs and Expectations, draft chapter for Cole R. and Lorch R. (eds), Information, Buildings and the Environment, Blackwell Publishing
- Markoff, John. 2013. *For Autodesk, a Step Into a Nanoscale World*. New York: New York Times Online. February 25, 2013 1:00 pm
- Mostafa, M. 2003. *Accommodating Autistic Behavior in Design through Modification of the Architectural Environment*. Cairo: Doctoral Dissertation, Department of Architectural Engineering, Cairo University.

Mostafa, M. 2006. *Let them be Heard: Appropriate Acoustics for Autism- Special Needs School Design*. ArchCairo . 2006, 3rd International Proceedings, Appropriating Architecture- Taming Urbanism in the Decades of Transformation

Mostafa, M. 2008. *An Architecture for Autism: Concepts of Design Intervention for the Autistic User*. ArchNet-IJAR: International Journal of Architectural Research, 2(1), 189-211

Mostafa, M . 2014. *ARCHITECTURE FOR AUTISM: Autism ASPECTSS™ in School Design*. ArchNet-IJAR. 2014, Vol. 8 Issue 1, p143-158. 16p.

Menges, Achim; Weinstock, Michael. 2013. *EMERGENT TECHNOLOGIES AND DESIGN: Towards a Biological Paradigm for Architecture*. Taylor and Francis. Kindle Edition.

Newschaffer, Craig J. PhD ; Falb, Matthew D. MHS ; and Gurney, James G.PhD. 2005. *National Autism Prevalence Trends from United States Special Education Data*. Pediatrics: Vol. 115 No. 3 pp. e277 -e282; pediatrics.aappublications.org February 2, 2015

Willbarger. 1991. *Sensory Defensiveness in Children*, Santa Barbara, CA: Avanti Educational Program.
<http://drexel.edu/autisminstitute/> (accessed December 20, 2014)
http://www.autism.net.au/Autism_diagnosis.htm (accessed December 20, 2014)
<http://www.busmethodology.org.uk/process/> (accessed December 19, 2014)
<http://messbauer.com/content/multi-sensory-experience-developmental-disabilities-and-you>
<http://southpawenterprises.com/content/signsofspd.asp> (accessed December 20, 2014)
<http://www.usablebuildings.co.uk/fp/index.html>
<http://www.worldwidesnoezelen.com/content/view/337/207/>

Size matters in housing design

Christina Bollo¹

¹University of Oregon, Eugene, OR

ABSTRACT: Architects of assisted housing must be nimble to react to the shifting constraints placed on them by clients and funders. The objective of this paper is to provide a context for assisted housing requirements. Ultimately, understanding the history of dwelling-size changes can help architects anticipate future constraints, and help make adaptive changes to the design of buildings that were created in the context of past requirements.

The paper begins with a literature review of policies and precedents that have shaped housing size (both assisted and market-rate). It continues with a description of housing size trends in the private housing market and Low Income Housing Tax Credit assisted housing stock. This analysis shows that the size changes are the result of four driving factors: building and health codes, market conditions, federal regulations, and local housing preferences. The paper includes an empirical analysis of Low Income Housing Tax Credit dwelling size that reveals the quantitative results of the driving factors. The paper concludes with an explanation of both how and why the assisted dwelling size has varied from year to year.

KEYWORDS: Housing, LIHTC, Crowding dwelling, Subsidized

INTRODUCTION

The average size of the U.S. market-rate dwelling has grown steadily, from 141.68 m² to 201.51 m² (1,525 to 2,169 square feet) since 1987¹. During this time, the size of the average newly constructed assisted dwelling has remained steady, from an average in 1987 of 75.25 m² (810 square feet) to a peak in 2001 of 80.83 m² (870 square feet), back down to 77.11 m² (830 square feet) in 2013. Essentially, assisted dwelling units are becoming, relative to the market, smaller and smaller each year, with more and more constraints placed on their design. This investigation of assisted housing reveals a series of incremental “pushes and pulls” that have influenced the size of dwellings, both in terms of absolute size and dwelling type.

This change in the average size of newly constructed assisted dwellings is primarily related to *unit mix*: the ratio of studios, one-bedrooms, etc. in a given building or planned community. One key research question, then, is: Why has this mix varied so much from year to year? What are the forces that influence unit size and the mix of unit types?

1.0 POLICIES AND PRECEDENTS

1.1. Historical context

Beginning at the end of the 19th century, new cultural awareness influenced significant change in dwelling sizes for the urban poor. Crowding was a serious problem with tenement housing in the late 1890s and early 1900s in the United States, and tenement laws were included in the 1905 National Building Code (Listokin 2005). As the urban population boomed due to immigration and industrialization, the average dwelling area per occupant decreased. This can be seen both qualitatively (through Jacob Riis' stunning flash photography) and quantitatively (seven people in a 30.19 m² apartment was typical in the tenements (Eagle 2012)). There became a strong social interest in improving the conditions of tenement living, especially with regard to crowding and public health. By the 1930s, increasing the space, air and light for the urban working class was an institutionalized priority of the first federal housing programs. The size of apartments increased and, simultaneously, the absolute number of people living in them decreased.

But this change in conditions for the poor was too stark to be politic and there was popular reaction against the new standards in the name of austerity. After the Second World War, the regulation of room dimensions and arrangements was reduced in scope, based on the assumption that they were provided for adequately by the marketplace (Listokin 2005). By the time the Housing Reform Act was passed in 1949, the typical size of a new apartment in public housing was smaller than it had been in the 1930s though still much larger than the tenement housing.

In the 1950s and 1960s, children were seen as the social problem against which to engineer. Gwendolyn Wright notes: “By the 1950s.... Rooms were smaller, site densities were higher, and playgrounds or social areas inside the buildings were fewer. Housing authorities tried to discourage tenants with large families by

providing only small dwellings in new projects” (Wright 1981, 233). Using the size of the apartment as a means of family planning was not effective and there was a resultant increase in crowding.

There is no evidence of specific regulations related to dwelling size again until the 1970s when the federal department of Housing and Urban Development (HUD) updated the Minimum Property Standards (MSP) to include multifamily housing. These standards regulated the minimum dwelling size, as well as light and air standards. Conversely, in the 1980s, HUD created maximum dwelling size regulations through the institution of cost-containment measures for newly constructed apartments. These two actions had diametric outcomes for the size of dwellings: The MSP effectively increased the size of affordable dwellings yet at the same time cost-containment measures decreased the size of new dwellings. Ultimately, the effects of each appear to be negated by the other.

1.2. Recent trends in family housing units

Affordable housing moved into its privatized era in the 1980s and market conditions set dwelling size for Section 8 voucher-eligible apartments. The early Low-Income Housing Tax Credit (LIHTC) projects relied on market studies, if not the market itself, to determine dwelling sizes. By 1990, each state-level housing finance agency set priorities for the allocation of tax credits through Qualified Allocation Plans (QAP). By the mid 1990s, state agencies adapted the HUD Minimum Property Standards to include guidelines for minimum and maximum dwelling size.

During public housing revitalization in the 1990s, unit mix was seen as a way to social engineer the ghetto. During the initial community meetings for the Boston Public Housing revitalization, debates phrased in terms of “dwelling mix” raised questions of race:

Should the housing authority base its dwelling mix on the immediate need to rehouse existing residents? Should it be determined on the basis of the projections of the development-based waiting list, skewed toward the particular preferences of South Boston whites, 80 percent of whom requested one- or two-bedroom apartments? Or should the dwelling mix of the revitalized development attempt to reflect the broader pattern of Authority-wide demand (Stone 1993, 133)

Ultimately, the housing authority decided to restrict large families within the project, “to further minimize risk,” permitting only enough large dwellings to meet the legitimate needs of current tenants and skewing the rest of the dwelling mix toward one- and two-bedroom apartments to attract smaller families, including more elderly.

The 2000s did not see a large shift in dwelling size, though there is evidence, explored later in this paper, that the HOPE VI program has resulted in a change in the distribution of dwelling types, from “large-family” (three- and four-bedroom dwellings) to “small family” (one- and two-bedroom) dwellings. Multiplied across all of the HOPE VI projects, this trend has the potential to significantly reduce the dwelling size of public housing. From 1994 to 2012, 260,000 dwellings of public housing have been demolished or sold in the United States (HUD 2012), though the data on the number of those that were three- and four-bedroom dwellings is not readily available.

1.3. The smallest units

The conflicting HUD policies of the 1970s and 1980s relate to the very smallest dwellings available to low-income people. At the start of the 20th century, more than 11 million people lived in SROs in the ten largest U.S. cities. In 1973, the HUD’s minimum Property Standards forbade the use of Single Room Occupancy (SRO) dwellings as permanent housing because the dwellings lacked individual kitchens and bathrooms within the dwelling (Fodor 1998). Numerous affordable accommodations were thus removed from the market.

The senior housing program, HUD 202, has undergone many changes over its tenure that can illustrate trends in dwelling size change. In 1981, HUD institutionalized cost containment measures for these projects, and required that new efficiency apartments (kitchen and bath en-suite, with one room for sleeping and living) be less than 50.17 m² (415 square feet) and one-bedroom apartments, less than 50.17 m² (540 square feet). In addition, the cost containment measures required that 25% of new or rehabbed dwellings be efficiency dwellings, rather than one-bedroom dwellings (Turner 1985). As a result, the average size of a one-bedroom size dropped from 4-9% across the four HUD field office study sites.

Because Section 202 tenants pay 30% of their income toward rent, each resident pays the same amount whether she is living in an efficiency apartment or a one-bedroom apartment, resulting in resentment between residents. Efficiency apartments may create hardship for seniors, many of whom are moving out of their single-family homes. “A 415 square foot efficiency apartment provides little space for traditional furniture, for even a portion of a lifetime’s accumulation of possessions, for entertaining, or for private activities” (273 Turner 1985). HUD made changes to the program in 1992 and eliminated the 25% efficiency apartment requirement and now their senior-housing guidelines actively discourage new efficiency apartments.

However, the existing efficiency apartments continue to plague the HUD 202 system. In 2008, HUD issued a memorandum allowing Section 202 projects to convert efficiency apartments that had experienced less than 75% occupancy to convert to one-bedroom apartments. Building owners may join two adjacent efficiency dwellings and combine them into a one-bedroom dwelling (HUD 2008). This results in a one-bedroom apartment that is larger than the maximum allowed. It also results in a net loss of dwellings and a net gain in dwelling size.

1.4. Underhoused and overhoused

Though there were dramatic examples of crowded tenement housing, crowding has been reduced significantly in the United States. While 20% of all U.S. homes had more than one person per room, and 9% had more than 1.5 people per room in the 1940s, by 2000, only 5.7% of dwellings had more than one person per room. Crowding decreased for all incomes from 1985 to 2005, including those earning less than \$25,000 a year for whom the incidence of crowding (more than one person per room) fell from 4 to 3% in that time period (Blake 2007).

In the early 20th century, encouraging Americans to have bigger homes made sense because of crowding. According to three economists (Kevin Blake, Edward Glaeser and Rachel Dwyer), this is no longer rational because Americans are so significantly overhoused. In 2000, on average, each American had more than two rooms and 92.16 m² (992 square feet) of living space (Glaeser 2011).

There are differences in overhousing related to tenure, type and income. In terms of tenure, Kevin Blake of Econometrica finds that in 2005, the median *owner-occupied* home was 172.61 m² (1,858 square feet) compared to the median *rented* home of 124.86 m² (1,344 square feet). The economist Edward Glaeser suggests that because home ownership is tightly tied to housing *type* (85% of single-family houses are owned and 85% of apartments are rental) the U.S. is essentially subsidizing people to live in large single-family houses instead of smaller apartments in denser environments. Furthermore, the home mortgage interest deduction subsidy scales with the size of the mortgage, exacerbating the problem (Glaeser 2011). Rachel Dwyer finds that higher status populations tend to occupy newer housing while lower status groups tend to be restricted to older housing (Dwyer 2007). Because older dwellings tend to be smaller than new dwellings, the differential in dwelling size for the poor and the middle expands even more.

1.5. Energy use as an effect of overhousing

The increasing costs of heating and cooling are also a market condition that may influence dwelling size. Barry Fischer (2013) found that when heating energy use is controlled, electricity use correlates positively with home size: a 400 m² (4300 square foot) home uses, on average, twice as much electricity as a 140 m² (1,500 square foot) home. Fischer's analysis shows the role income plays in energy use: households in the top 20% income bracket who live in a 140 m² (1,500 square foot) home use four times as much electricity as the bottom 20% in the same sized home (Fischer 2013). According to AHS findings, lower-income homes tend to be older, less well insulated and have older less-energy-efficient appliances and space heating systems, and yet they still use less energy per person than their higher-income cohorts (Energy Research Consortium). More nuanced research may reveal that dwelling size is the most important determinant of energy use. Low-income people are motivated to conserve energy because of the cost (Dastrup 2012) and they are aided by the lower average size of their dwellings.

2.0 QUANTITATIVE ANALYSIS

In order to triangulate the evidence from the literature, and to answer the research question about how size matters comprehensively, empirical analysis is necessary. An examination of publically available LIHTC project data reveals historical dwelling change patterns as well as providing substantiation of some of the evidence on dwelling size change from the literature.

2.1. Unit mix

The state agencies that allocate Low Income Housing Tax Credits create Qualified Allocation Plans (QAP), affecting dwelling size in two ways: through preferences and through design guidelines. Preferences are created because tax credits are allocated competitively and each state sets its own preferred set-asides. In 1990, 29 states had stated preferences related to dwelling type (number of bedrooms per dwelling); in 2001, 30 states had dwelling-type preferences, though only 20 states overlapped, meaning between 1990 and 2001, 39 states attempted to influence dwelling type at some time. In 1990, 50% of the QAPs with preferences favored large-family dwellings (three-bedrooms or larger) but only 25% favored large-family dwellings in 2001.

The LIHTC data reveals a general movement toward increased dwelling size (Fig. 1), peaking in the early 2000s, with a shallower slope toward smaller dwellings since. There is a sharp increase in the early 1990s

toward more three- and four-bedroom dwellings and then they flattened out at 20% and 3% of total dwelling types, respectively. In the meantime, studios have held steady at 6% of total LIHTC dwellings.



Figure 1: Trends in Unit Mix in LIHTC Projects, 1987-2010

The trend of one-bedroom apartments is intriguing: graphically, there are two peaks at 45% in the early 1990s and mid-2000s surrounding a ten-year wide trough at 30%. This trough (Fig. 1) is during the era of public housing demolition and one hypothesis is that the LIHTC housing providers were responding to an influx of large families relocating from public housing. Another hypothesis is that housing providers have a static number of dwellings they choose to provide, but the dwelling mix is dynamic, dependent in part on the preferences and set-asides of the state’s qualified allocation plan. Therefore, as three-bedroom apartments increase, one-bedroom apartments decrease.

The percentage of studio apartments has experienced two sudden increases, in 1992 and 2009. These spikes occur at the same time as the one-bedroom increases mentioned previously, and the two conditions may be related. Another influence may be the result of plans to end homelessness. Significantly, studios created through LIHTC account for 8% of the projects sponsored by non-profits and 3% of the projects developed by for-profit entities.

2.2. Unit size

Only a handful of states had design guidelines associated with their QAPs in 2004 and all states have some design guidelines in 2013. The Oregon Housing Finance Commission is a case study for this section of the paper, in part because the state uses the guidelines to control the size of dwellings, regulating both a maximum and minimum for each dwelling type (Table 1). Occasionally, conflicts arise between the LIHTC minimum and HUD maximum. For example, Oregon’s minimum one-bedroom size is 55.74 m² (600 square feet) and the maximum for HUD 202 is 50.17 m² (540 square feet) so the conflicting requirements must be negotiated if there is HUD 202 funding involved.

Table 1: Oregon Housing Services 2011 Architectural Guidelines

Unit Type	Minimum Required Unit Floor Area, m ² (square feet)	Maximum Required Unit Floor Area, m ² (square feet)
SRO	16.25 (175)	
Studio	32.50 (350)	
1 Bed / 1 Bath	55.74 (600)	64.10 (690)
2 Bed / 1 Bath	74.32 (800)	83.61 (900)
3 Bed / 2 Bath	92.90 (1000)	111.48 (1200)
4 Bed / 2 Bath	116.13 (1250)	130.06 (1400)

Though this empirical study analyses changes in average dwelling size and dwelling mix, it does not focus on dwelling area by type nor residents per bedroom nor residents per m² and many questions remain. Is a subsidized studio apartment getting smaller as building codes are adopted and the minimum size decreases? What is the actual size difference between a three-bedroom and a four-bedroom apartment? For example, in Oregon, the minimum for a four-bedroom apartment is 116.13 m² (1250 square feet), and the maximum for a three-bedroom apartment is 111.48 m² (1200 square feet). How does that affect perceptions of crowding when there could be, legally, 2 more people sleeping in that extra five square meters?

CONCLUSION

The LIHTC dataset employed for this research contains data for all 50 states, but its use is limited by the lack of detail. State agencies collect additional, dwelling-scale data that could provide a more thorough picture of dwelling size change in LIHTC housing. The American Housing Survey (AHS) could help to answer some of these questions because it contains dwelling size data for its sample, as well as tenant satisfaction data. The AHS also includes a sample of remaining public housing dwellings, as well as HOPE VI and HUD 202/811 dwellings, which would provide a more complete picture of dwelling size and dwelling size change in U.S. affordable housing. cursory evidence from the AHS suggests that, of the 17 million rental dwellings affordable to households at 50% of area median income, only about 5 million dwellings, or approximately 30%, are subsidized.

The subject of dwelling size calls for a larger empirical and historiographical analysis, with panel data and an inventory of HUD and State requirements over time. A Building Code historiography may reveal why New York and San Francisco view 28 m² (300 square foot) apartments as “micro-living” while Seattle and Portland have been building 21 m² (220 square foot) dwellings to little fanfare for several years. A systematic inventory of zoning laws would expose the forces working against shared living and accessory dwellings. An architectural analysis of dwelling design at different sizes would help policy-makers and architects of affordable housing. The subject of dwelling size, and dwelling size change, is interdisciplinary, simultaneously architectural, sociological and political, and a compelling topic for further study.

ACKNOWLEDGEMENTS

This research received essential feedback from Carlos E. Martin of the Urban Institute and from Thomas Collins, Howard Davis, Erin Cunningham, Mark Gillem, Trudy Cameron, Alison Kwok.

REFERENCES

- Fischer, B. March 6, 2013. “America’s energy distribution: the top 1% of homes consume 4 times more electricity than average (and why it matters).” *Outlier*.
- Gustafson, J. et al. 2002. “Analysis of State Qualified Allocation Plans for the Low-Income Housing Tax Credit Program.”
- Listokin, D. Hattis, D. 2005. “Building codes and housing.” *Cityscape*.
- Roberts, M. 1990. “Gender and housing: the impact of design.” *Built Environment*.
- Stone, M. 2010. *Shelter poverty: New ideas on housing affordability*. Temple University Press, Philadelphia.
- Turner, M. 1985. “Building housing for the low-income elderly: Cost containment in the section 202 program.” *The Gerontologist*.
- Wright, G. 1981. *Building the dream: A social history of housing in America*. MIT press, Cambridge.

The new factory, the new city, and an expanded idea of urban ecology

Howard Davis¹

¹University of Oregon, Eugene, OR

ABSTRACT: This paper puts a transformed building type, the contemporary factory, into a theoretical framework that is guiding a larger research program concerning the city as a locus for value-added production. American cities are experiencing the beginning of a manufacturing revival, with much new industry cleaner, smaller, spread over smaller firms, and located closer to residential areas than the “old” industry was. This is important in policy and the emergence of new types, and also helps further an understanding of cities as complex adaptive systems. Urban ecology can be expanded to include understandings of urban social and economic structure.

The work is based on the following two conjectures: (1) Craft and manufacture, or adding value to material inputs, is analogous to the increase of organization in an ecological system, and (2) The city’s resilience is analogous to the resilience of an ecological system. These ideas are being tested with research in London, including historic investigations of the geography and architecture of furniture manufacture, and in Portland, looking at the establishment of small manufacturing firms, with products such as bicycles, outdoor clothing and food. Using mapping, historic directories, interviews and architectural analysis, the work is leading to representations that combine physical and economic pictures of urban districts and building characterized by small manufacturing firms.

The research is showing 1) that urban resilience and inclusivity may be supported by a variety of sizes of buildings, some with a fine-grained distribution among other uses, and flexible in their function and patterns of ownership; 2) that although old factories and warehouses may often be usefully retrofitted for new industrial uses, there is a need for accurate typological specification of buildings and spaces for such new uses; and 3) there is a need to define industrial zones close to the central city and residential districts.

These results suggest the need for initiatives in zoning, financing and development, and how relationships between urban form and function help expand ideas of ecology to include social and economic configurations.

KEYWORDS: Urban Production, Urban Ecology, London, Portland, Factories

INTRODUCTION

Toward the end of the twentieth century the American city experienced the replacement of manufacturing with the service and knowledge economies. Material goods—clothing, furniture, food—are sold and consumed in cities, but their production takes place elsewhere, in places with very low labor costs, made possible partly by the low unit cost of container shipping. To large extent cities have become places of consumption. This has allowed American industry to provide large quantities of goods at low cost, and it has also provided a means for many people in so-called developing countries to enter the labor market, as the first step toward economic independence. But it has also proven difficult to ensure workplace safety and fair working conditions, as evidenced most tragically two years ago by a factory collapse in Bangladesh in which over 1100 garment workers were killed. Container shipping has negative environmental effects. And less measurable but also harmful is the separation between people and the source of the things they use the most in their everyday lives, without knowledge of where they come from, how they are made, or who made them.

Partly as a reaction to these issues and partly because of rising labor costs in Asia, manufacturing is returning to American cities. The volume is still small, and some of it is in the form of “niche” operations that cannot compete with the enormous volume of offshore manufacturing—but there is enough to raise questions about its effect on buildings and urban form. Some new industry may be in smaller shops; it may be cleaner; production, design and sales may be more closely related; it may be closer to residential areas. Even if industry does return to our cities, the paradigm of twentieth century industrial space, with single-use factories removed from other urban functions, may require change.

A series of investigations into historic and contemporary urban industrial formations has helped contribute to

an understanding of what the new paradigm might be. These investigations, in London and in Portland, Oregon, are yielding two kinds of conjectures. First are ideas about urban design and building types, which are helping me develop prototypes and patterns that directly influence design, planning and policy. Second are more theoretical ideas, based on seeing the city as a complex adaptive system, and the importance of production within that formulation. This paper will describe two case studies currently underway, and how they support each of these two kinds of conjectures.

1.0 LONDON

In the nineteenth- and early-twentieth-century furniture industry in London, furniture manufacture was concentrated in at least two places: the adjacent districts of Shoreditch and Bethnal Green, and the area around the northern end of the Tottenham Court Road. Both places have undergone massive changes beginning in the mid-twentieth century, as the result of redevelopment and rebuilding following World War II bombing. But using historical business directories and large-scale historical maps, it is possible to gain an understanding of the historic geography of the industry.

Table 1: 1839-1841, East side of Tottenham Court Road, 1839-1841. Source: (Edwards 2011)

137	new and second-hand furniture warehouse	195-196	piano manufacturer
142	wholesale leather warehouse	196	French bed-maker
147	upholstery and furniture	204	upholstery warehouse
154-156	drapers	211	furniture ironmonger
167	upholstery and furniture	219	cabinet-maker and upholsterer
169	glass and lustre manufacturer	231	upholsterer
170	cabinet-maker	240	trimming warehouse
177	fringe manufacturer	246	plate glass supplier, carver, and gilder
178	whitewood manufacturer	247	furnishing ironmonger
185	furnishing ironmonger	258	upholsterer and cabinet-maker
193	furnishing undertaker		

Tottenham Court Rd is now lined with large commercial buildings with retail shops. Some of the shops are large furniture stores, continuations of the furniture businesses that were there before. But historical photographs and maps confirm that those businesses were once housed in much smaller premises, most of which were variations of the London terraced house. The 1839-1841 business directory for just a portion of one side of the street indicates a rich mix of businesses (Table 1).

The majority of the buildings were narrow terraced houses, 20' or so wide. The list along with the views of the street facades suggests several things about the local geography of furniture making:

1. Manufacture and sales happened in relatively small shops.
2. There was a competition among businesses offering the same goods or services.
3. Manufacture of furniture was geographically interspersed with sales, as well as with materials suppliers and the manufacture of components of furniture (furniture ironmonger, fringe manufacturer).
4. Businesses were mixed with residential accommodation.

Only one principal street is represented here. Further research will indicate whether side streets have a similar mix, proportionally more suppliers and subcontractors, neighboring shops such as groceries and pubs, or some other arrangement. But even looking at this one street, a complex economic structure, accompanied by a particular set of physical characteristics, is suggested. This structure has functional redundancy (in the repetition of types of businesses), functional hierarchy (sales, manufacture, manufacture of parts, supply), adjacency of different kinds of uses, and spatial flexibility (seen in an examination of the same house numbers over multiple years, as uses change).

As the street changed, retail uses began to predominate as manufacture moved to larger factories further out from the center of the city. Already by 1915, the same section of the east side of Tottenham Court Road looked very different, with most businesses named "house furnisher" rather with the name of a specific trade. By 1915 there was much less specialization of individual businesses, increase of size of businesses and their consolidation into multiple buildings, and a change from manufacturing to sales. Today, there are a few large furniture retailers on the street, and although there is still evidence of the old building fabric, the street is characterized mostly by large buildings with long frontages, many of them built in the last ten or fifteen years.

2.0 PORTLAND

In Portland, we looked at a district that has been the site for industrial uses for over a century. Located near downtown, the district has been designated by the city as an "industrial sanctuary," and large parts of it have been resisting the efforts by housing developers to rezone, raise land values and change uses.

In the nineteenth century, docks, warehouses and factories began to occupy the western part of the area, and then most of the area was transformed to warehouse and industrial uses. Now, virtually all buildings have those uses. Zoning was introduced in 1924, but until the 1960s, there were few zoning categories, and the ordinance made no distinction between retail and manufacturing uses.

Beginning several decades ago, many light industrial and warehouse uses left the area because they needed larger buildings or better access to transport. But in the last twenty years, the district has gained a renewed life with new businesses, many associated with the growing artisan, technologically-oriented, small-scale economy. They include craft distilleries, microbreweries, woodworkers, designers of prototype clothing sold to NASA and Nike, furniture refinishers, coffee roasters, workshops in which anyone can rent space and share equipment, recording and art studios. In some cases these businesses are in buildings that once housed businesses such as produce distributors, lighting-fixture warehouses, welders, auto-body shops, that served the twentieth-century industrial economy.

We looked at typical buildings in the neighborhood in two ways: (1) the history of the building, emphasizing the succession of businesses that occupied it since its construction, and (2) the history of the business now in the building, in terms of why it moved from location to location, eventually finding itself in this building.

One building houses a business that designs and makes prototypes and small production runs of products sold to organizations like Nike and NASA. The building was originally built as an auto-body shop in the late 1930s. After ten or fifteen years; the building was occupied by the United Salad Company, one of a number of vegetable distributors in the area. They used the building to park their trucks and as warehouse space for produce before they moved to a larger facility near the airport. The present owner bought the building fifteen years ago. He was originally looking for a smaller space, but bought the building realizing that there was enough of a market to be able to rent space to other creative businesses. Other tenants include a woodworker, a sign maker, and a card printer.

A second example is a building built in 1964, for a wooden-box company serving the produce markets—an example of synergies between different businesses. Trees that came into the building were cut and milled; and the boards nailed together to make the boxes. The current owner began a woodworking business in a garage, moved to a five-thousand-square-foot rental space nearby, then rented this building, and finally bought it. His business reproduces historic milled sections for a national customer base. The building allows large trailer trucks to enter at one side and leave on the other, facilitating materials delivery and product shipments. Most of his fifteen employees bicycle to work.

The third example is a building occupied by a company that restores old building components and furniture. The building was built in 1902 as a garment factory. Three years later an addition was built, and later a second floor was added. In the 1930s the building was sold to the Oregon Flower Growers Association and became the Portland Wholesale Flower Market until 1990. The present company moved into the building in 1992. Since 1992, along with the primary occupant, a variety of tenants have occupied the building, including two door-and-window companies, a design firm, two custom contracting firms, a café and an architecture firm.

The company was founded in 1977 in a small facility in north Portland, consisting of a store and factory. Five years later the business moved to a larger mixed-use building that included apartments; in 1986 it moved to a space with 7700 square feet; and in 1992 to the present location with 47,000 square feet. Finally, in 1998, the factory function was moved to a new location almost double the size of the existing building, separating the factory from the retail location.

These three buildings exemplify other buildings in the area, and share common attributes. They all originally housed businesses that were secondary to the earlier manufacturing and distribution economy: auto repair, fruit-and-vegetable wholesaling, wooden crate manufacture, garment manufacture. Many of these businesses ultimately moved to larger buildings. The buildings we're looking at now house businesses associated with the so-called "new economy": design prototyping, furniture sales, distillery, physical therapy, environmental engineering. And many of those businesses began in people's garages or smaller spaces, and moved to the area because it is convenient for their customers and because the buildings could be readily re- configured for their business.

Four attributes have helped keep the district attractive for new businesses.

First, is its location. It is easily available to the central city and to the gentrifying residential districts to the east. This is ideal for businesses that need visibility to a young professional population, like the distilleries and micro-breweries, that is interested in coming to work by bicycle or public transportation.

Second, the 200' x 200' block, characteristic of central Portland, puts a maximum size on buildings, so that when businesses expand they may move to places where warehouse and industrial sites can be much larger—allowing these buildings to become available for smaller and newer businesses.

Third, although the area has good access for smaller trucks, it is not as convenient for large semi-trailers or rail cars, for which larger sites outside the central city are more suitable.

Finally, the zoning of large sections of the area prohibits or highly restricts residential uses, keeping land values down and making land available to smaller, start-up businesses.

3.0 COMPARISONS

There are similarities between the Tottenham Court Road district and the East Side Industrial District. Both districts had easy proximity to the residential areas where the labor force lives; in both cases there were relatively small buildings; in both cases businesses moved out when they expanded; in both cases there was both a mix of kinds of businesses and synergies between primary and secondary businesses in the same industry; in both cases buildings were flexible enough to easily accommodate new uses. Although London and Portland are quite different from each other in their history and visible urban form, the fact that they share features that relate function, urban structure and use suggests the possibility of a theoretical formulation that incorporates them both.

4.0 AN EXPANDED IDEA OF URBAN ECOLOGY

"Urban ecology" and "urban resilience" are part of contemporary discourse concerning sustainability.

Urban ecology deals with relationships between urban built form and natural processes, including such issues as species diversity, effects of urbanization on natural habitat, water flow, the temperature effects of cities, etc. Here, ecology refers to biological systems, and research in urban ecology tends not to be extended into the more general realm of complex adaptive systems.

Urban resilience largely deals with the city's ability to recover from sudden, large-scale disturbances, such as storms, earthquakes, wars, and large human migrations such as a rapid influx of refugees. It tends not to deal with issues of slower change such as development, gentrification, or displacement.

In the last chapter of *The Death and Life of Great American Cities*, "The kind of problem a city is," Jane Jacobs suggested seeing cities as phenomena of "organized complexity." "The history of modern thought about cities is unfortunately very different from the history of modern thought about the life sciences. The theorists of conventional modern city planning have consistently mistaken cities as problems of simplicity and of disorganized complexity, and have tried to analyze and treat them thus." (Jacobs 1993, 567) Recent work of Stephen Marshall, Luis Bettencourt, and Michael Batty, for example (Marshall 2008; Batty 2013; Bettencourt, Offenhuber and Ratti 2013) has looked at cities in terms of organized complexity, and there is ample work in business, economics and sociology to support this formulation. The argument may be continued by suggesting a direct analogy between ecological systems that are based on biological organisms and their environment, and urban systems that are economic, social and architectural (as well as biological). Table 2 summarizes this.

Table 2: An ecosystem-city analogy

ECOLOGICAL SYSTEM (BIOLOGICAL)	URBAN SYSTEM, OR CITY
STRUCTURE	
species	type
individual within a species	a particular business, family or person
species diversity	diversity of people, businesses or building types
genetic codes	cultural and procedural norms
scales of systems and subsystems	scales of systems and subsystems (not spatial)

SPACE AND PHYSICAL ORGANIZATION	
habitat	buildings, streets, districts
patch (a place where a species is clustered)	an area where particular classes, affinity groups, ethnicities, kinds of businesses or buildings are clustered
ecotone (the boundary between two biomes, or ecological zones)	building or district edge that "belongs" to places on either side of it
FUNCTION	
energy inputs	inputs of raw materials or products
energy and information transfer between organisms	social and economic relationships and transactions
increase of biological organization, growth, reproduction	production of goods, buildings, the city itself. Added value to materials or products.
resilience	resilience; flexibility of buildings and districts

In this table, ecological systems and urban systems are treated in parallel ways. Species are analogous to types, habitat to physical elements of the city, ecotones to edges between ecological zones, genetic codes to cultural and procedural norms. The idea that a city is a complex adaptive system provides a theoretical framework that helps explain the importance of particular attributes. If the ground-floor edge of a building is indeed like an ecotone, the importance of seeing that edge like a thick boundary, containing functions both of the street and of the building, is more clearly seen. Jane Jacobs wrote about the importance of having buildings of varying ages in a district, to support economic enterprises at different stages of development; this is one manifestation of species diversity.

So there are now at least two kinds of urban ecology:

1. The usual definition, which we call "urban bio-ecology," the relationships among built form, urban systems, and the biological organisms and ecologies that are in or are affected by the city; and
2. A new definition, which we call "urban socio-economic ecology," the relationships among built form, urban systems and the economic and social structure of the city.

In each case, the system being considered is a complex adaptive system, and because of this, the two systems have similarities of structure and function. The usual idea of urban (bio-) ecology has helped to give rigor to questions of the city's impact on plants and animals: the need to take actions that mitigate this impact is given increased urgency through the knowledge that an entire ecosystem is affected. The same kind of importance may be ascribed to the city's socio-economic ecological system and the role of individual elements—and actions affecting them—within it.

And to extend the point, the physical environment is implicated with each of the two ecosystems. In the urban bio-ecological system, such elements as habitats, wildlife corridors, and ecotones provide physical frameworks for bio-ecological function. In the urban socio-economic ecological system, configurations of buildings, streets, transportation systems and open spaces provide physical frameworks for social and economic function. (Of course, these "two ecologies" are not independent of each other. But even in their interdependence, it is important to recognize the existence and role of social and economic elements and relationships.

How does this apply to the industrial district in London and Portland? Referring back to Section 3.0, both districts have repetition of small units and therefore a potential redundancy of buildings and businesses; both have a mixture of kinds of businesses with functional synergies among them; both have resilience that is associated with the flexibility and adaptability of buildings. Although the two districts differ in their uses, outward physical forms, economic purpose and cultural background, they share deep structural attributes that are connected to their socio-economic ecological systems.

5.0 MANUFACTURE AND THE INCREASED ORGANIZATION OF AN ECOLOGICAL SYSTEM

But it is the realm of function that is perhaps most important. In a working paper for the Santa Fe Institute that has the same title as Jane Jacobs' question, Luis Bettancourt suggests that the analogies used to describe cities have focused on form rather than urban processes. But it is with the functional analogies that production is important.

When something is crafted or manufactured, value is added to it. The energy added to the product through the making process results in a higher level of organization, analogous to the emergence of order in a bio-ecological system. Likewise, a city's production activities may be critical to its health as a socio/economic ecological system. These activities are part of the input/output flows of money and materials, have controlling mechanisms of contracts and social agreements, and provide sustenance to the other systems. This is the meaning of adding value to materials or to goods that are in the process of manufacture. Those materials or goods become more ordered, more organized through the production process in which materials and energy are being brought into the equation.

Furthermore, in both biology and material production, the entire system gets more ordered so that order can be increased in the thing which is produced. To be able to add value to a product, aspects of the entire system need to have value added as well. In the case of manufacture, higher levels of organization in the overall system are achieved through such things as the development of craft expertise, systems of crafts organization and training, the manufacture of tools and machines, the setting up of assembly lines and production protocols in factories, the development of complex and responsive supply chains, the emergence of systems of accountancy and law, the development of design and prototyping practice. Urban production processes use energy and materials to provide the city itself with higher levels of functional and material organization.

The functions of adding value through manufacture require buildings in which these functions can happen; the buildings, in turn, may be specialized in their design; and their location must allow for the complexity of association with other businesses required by the structure of the system. This was seen in the Tottenham Court Road furniture industry with its mixture of retail shops, small factories and suppliers, making use of buildings that were either built for particular purposes or that were flexible enough to adapt to accommodate those purposes, and possibly with a street system that provided for different degrees of access depending on necessary visibility to the public (this last statement is still to be tested in the research). And similar attributes are present in Portland's East Side Industrial District, where flexibility of use allowed for synergies, for example, between produce-distribution firms, other firms servicing trucks, and still other firms making wooden crates for distribution of the produce.

6.0 MANUFACTURE AND A RESILIENT BUILT ENVIRONMENT

Well-functioning ecological systems, as complex adaptive systems, are resilient in their response to disturbances: they "bounce back" after the disturbance without irreversible damage to the overall system. (Holling 1973) This ability depends on diversity, redundancy of parts, and redundancy of connections between the parts. Functionality may be through a structure that is essentially that of a network with multiple paths between points. Disturbances in bio-ecological systems may include weather events, invasions of foreign species or man-made changes. In the case of socio-economic ecological systems, disturbances may include such things as sudden increases in population, recessions and depressions, changes in sites of manufacture, or changes in import/export balances.

If such changes are to be effectively dealt with, the physical environment needs to accommodate them. When large firms greatly downsize or disappear, as happened in Detroit and other "rust belt" cities, existing buildings need to house new start-up businesses to fill the gap. In New York, the Brooklyn Navy Yard, once an enormous government-run operation for the construction of aircraft carriers and naval destroyers, now houses hundreds of small industrial and design firms, occupying the old buildings. In Portland's East Side Industrial District, the success of firms occupying small buildings allowed them to move to larger buildings elsewhere—but then freeing up the original buildings for new, small firms. The resilience of the buildings—i.e., their ability to be physically adaptable in the face of change—supported the resilience of the economic system they housed.

7.0 CONCLUSION: IMPLICATIONS FOR RESEARCH, DESIGN, PLANNING AND POLICY

The speculative theoretical ideas described here provide the basis for research that links the city as a site of material production with the city as a complex adaptive system, making both urban theory and ecological theory more robust, and giving additional justification for advances in design and policy that support the city as a site of production.

As manufacturing returns to cities, it will take on a different form than it had during most of the twentieth century. Building types and urban formations that can support this new manufacture in efficient and human ways may include:

- Mixed land uses, even for certain kinds of industrial buildings,
- A variety of lot and building sizes,
- Public transportation serving industrial uses,

- Efficient systems of materials and product distribution,
- Adaptability of buildings allowing for small firms to come and go,
- Closer relationship between industrial uses, dwellings and residential areas,
- Vertical factories allowing for efficient land use,
- Sharing of facilities for incubator businesses and start-ups,
- Buildings in which humane workplaces can be designed.

The further development and refinement of these attributes, which can be implemented in design, zoning and development practice, represent one practical result of the research. As part of an overall research program, this work is happening, through design investigations, actual building and development projects, and studies of ongoing projects that involve new small industries, startup manufacturing, and incubator/shared production facilities.

The research as a whole, therefore, puts practical understandings of the form of the (re)-emerging industrial city into the context of a theoretical understanding of urban form and function, as an expanded idea of urban ecology.

REFERENCES

- Batty, M. 2013. *The New Science of Cities*. Cambridge: MIT Press.
- Bettencourt, L.M., D. Offenhuber and C. Ratti, "The kind of problem a city is." In Bettencourt, L.M., D. Offenhuber and C. Ratti (eds.) *Die Stadt Entschlüsseln: Wi Echtzeitdaten Den Urbanismus Verändern*. Heidelberg: Birkhauser.
- Edwards, C. 2011. "Tottenham Court Road: The changing fortunes of London's furniture street 1850-1950." *The London Journal*, Vol. 36 No. 2.
- Holling, C.S. 1973. "Resilience and stability of ecological systems." *Ann. Rev. of Ecology and Systematics* Vol 4: 1-23.
- Jacobs, J. 1993. *The Death and Life of Great American Cities*. New York: The Modern Library.
- Marshall, S. 2008. *Cities, Design and Evolution*. London: Routledge.

Therapeutic goals of hospice care environment: A systematic literature review

Sharmin Kader¹, Keith Diaz Moore²

¹University of Kansas, Lawrence, KS

²University of Utah, Salt Lake City, UT

ABSTRACT: Identification of environmental Therapeutic Goals (TGs) has proven essential in providing useful guidance for planning and design (Cohen & Weisman 1991). Though age-specific environmental dimensions have been suggested by several researchers during 1980's to 1990's, none of them focused on dying patients and their experience in hospice care environment, so the need for categorizing dimensions for hospice environment is evident. The objective of this study is to identify the Therapeutic Goals of hospice environment focusing on patients' experience. This study employed a systematic literature review with an approach developed by Hawker and colleagues in 2002. This study had considered a wide-ranging literature search: 7 electronic databases search (PubMed, PsycINFO, Social Science Citation Index, Science Citation Index, ProQuest Dissertations & Thesis, Avery, and Cochrane Library), reference list search, examination of literatures recommended by relevant experts, and Google search for books, reports, and guidelines. In total 48 literatures included; 39 full text articles, 2 books, 5 guidelines, and 2 reports. The data has extracted from these literatures onto a standard template (matrix) for comparison and analysis for coding and thematic development. The study identified eight themes as TGs which have direct influence on patients' experience of hospice care environment: provide continuity of self, provision of access to nature, provision of privacy, facilitate social interaction, maximize safety & security, provision of autonomy, regulate stimulation, and provision of spiritual care. These goals reflect two characteristics; each expresses a basic or derived major patient's need, and a potential environmental facilitator for the satisfaction of the need (Lawton et al. 2000). As the physical environment of hospice has significant impact on the patients' quality of life and the possibility of a good death (Cohen et al. 2001), these TGs have a positive effect on patients' lives.

KEYWORDS: Hospice, Palliative care, End-of-life, Dying, Therapeutic environment.

INTRODUCTION

The physical environment of hospice has significant impacts on the patients' quality of life and the possibility of a good death (Cohen et al. 2001). The physical environment is a part of the entire care milieu which also includes personal, social and organizational dimensions (Figure-1) (Cohen & Weisman 1991). The organizational component is conceptualized in terms of the policies and programs, the social component is represented by family and fellow residents, and the architectural component is defined in terms of the experiential qualities or attributes of environments (Cohen & Weisman 1991). The TGs serve as unifying intentions which can direct congruent decision-making in the organizational, social, and physical realms and thereby provides a useful foundation for planning and design (Cohen & Weisman 1991). For instance, according to Lawton et al. (2000), eight core dimensions of TGs for the environment for aging person with dementia include safety, orientation, functionality, stimulation, personal control, social interaction, continuity and change. These authors go on to suggest that these dimensions reflect two characteristics. First, each dimension expresses a basic or derived major human need. Second, the dimension is one in which a potential environmental facilitator for the satisfaction of the need is evident. The physical settings of hospice along with the carefully designed organizational environment can contribute to the realization of desired therapeutic goals and have a positive effect on the lives of dying patients.

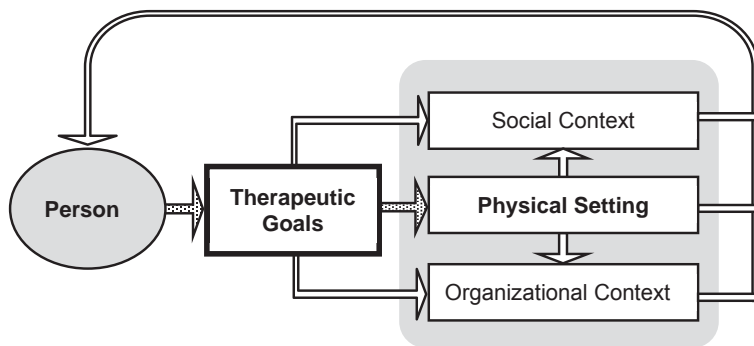

Figure 1: A conceptual framework for the organization of the person-environment system (Adapted from Figure 1.2, Cohen & Weisman 1991).

Since the beginning of hospice movement in America, mid-1970s, the architectural design of hospice has been considered similar to nursing home (Verderber & Refuerzo 2006). During 1980's to 1990's, several researchers have suggested age-specific environmental dimensions for nursing home settings, but none of them focused on environment for dying patients (Lawton 1983; Lawton et al. 1992). But in recent years, several studies begin to suggest differences in therapeutic needs of the hospice environment. Hospice patients are mostly bed-bound, their physical, social and spiritual demands are different, and family accommodations plays a significant role in care (Nakashima 2002; Silver 2004; Evans et al. 2006; Anderson 2007; Rowlands & Noble 2008; Rijbi et al. 2009; and Brereton et al. 2011). Also, several literatures (books, reports and manuals) have published addressing the design issues of hospice and palliative care facilities (Verderber & Refuerzo 2006; Moorhouse 2006; Worpole 2009). What is missing from the hospice literature is the identification of therapeutic goals by which to inform integrated design decision-making. The need for categorizing such therapeutic goals for the hospice and palliative care environment is evident and this is the aim of this study. The question guiding this study is "What does the literature suggest are the appropriate dimensions of the 'environment as experienced' and therapeutic goals for the hospice environment?"

1.0 METHODS

To develop a research-supported list of TGs for the hospice environment, a narrative literature review was completed using a systematic approach focusing on patients' experience of hospice care. This study employed the literature review approach developed by Hawker and colleagues (2002) which outlines a process by which to systematically and objectively reviewing research from different paradigms. A search of 7 electronic databases from 1998 to 2012 were searched including PubMed, PsycINFO, Social Science Citation Index, Science Citation Index, ProQuest Dissertations & Thesis, Avery and Cochrane Library. A total of 847 papers were identified and assessed by their title and abstract using the inclusion and exclusion criteria: published since 1998, written in English, for adult patients, hospice or palliative care facility. After the screening of titles and abstracts, 127 articles were selected. The second stage was assessing each of these papers objectively to seek relevancy. Any form of information about the physical environment of hospice or palliative care found in the text was included: 27 literatures were found eligible. An additional 12 records were identified from reference tracking. From Google search and experts' suggestions 2 books, 5 guidelines and 2 reports were added. Total 48 literatures included. The details of literature search and selection process are shown in Figure-2, the Preferred Reporting Items for Systematic Reviews and Meta-Analyses (PRISMA) flowchart (Moher et al. 2009).

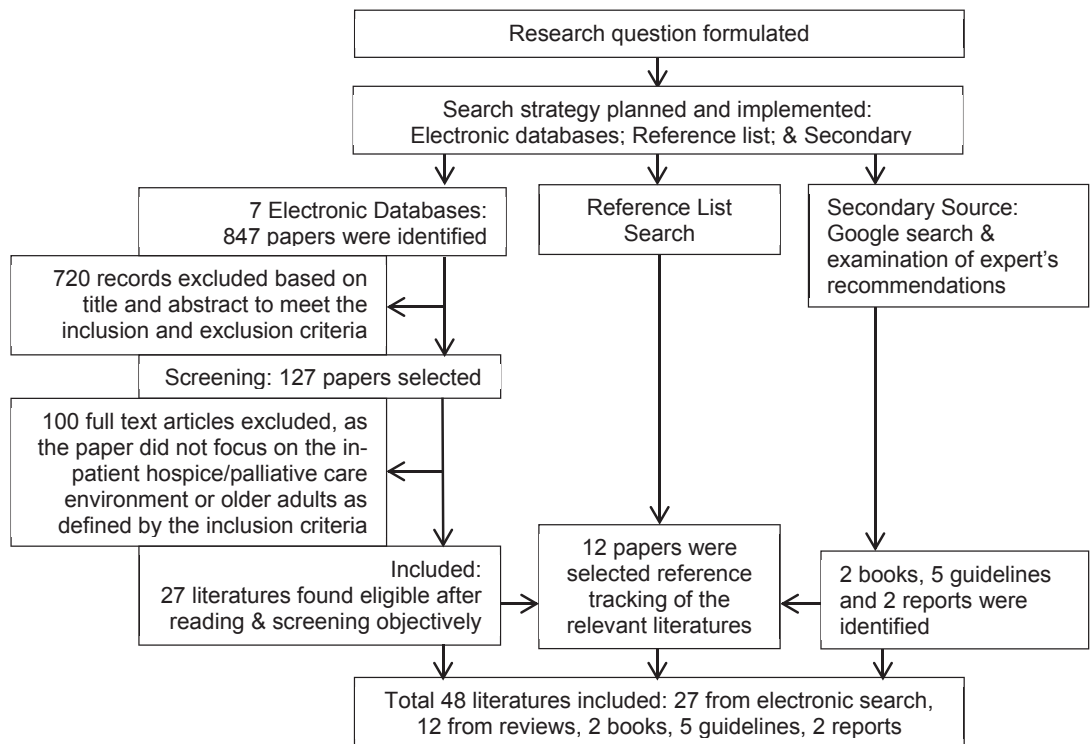

Figure 2: Preferred Reporting Items for Systematic Reviews and Meta-Analyses (PRISMA) flowchart

2.0 REVIEWS

All of these literatures have examined the physical environment of hospice or palliative care service. Some focused on design issues and some studied physical environment in the context of wider issues such as quality of care, patients' perception and experience, staffs' or family members' perspective about hospice care or setting, and patients' views on a particular concept such as dignity or a 'good death'.

Two books, five guidelines, two reports, two dissertations, and ten journal articles focuses on designing aspects of hospice and palliative care environment. In 2006, Verderber & Refuerzo wrote a major reference book "Innovations in Hospice Architecture", an overview of historical background of the contemporary hospice and its basic principles of design. Another book by Ken Worpole in 2009, "Modern Hospice Design", elaborates the architectural design challenges for palliative care. A series of hospice design guidelines and reports have published in Australia, UK and USA. In 2000, the "Hospice Unit Generic Brief" published in Australia. In 2005, the "Design Guidelines for Specialist Palliative Care Settings" has published by the Department of Health and Children of Irish government. Another guideline published in UK, "A Place to Die with Dignity: Creating a Supportive Environment" (NHS Estates 2005). In USA, the Hospice Education Institute published "Hospice Design Manual for In-Patient Facilities" (2006), written by Timothy Moorhouse. In 2010, Hospice Friendly Hospitals Programme published, "Quality Standards for End-of-Life Care in Hospitals". The King's Fund's Enhancing the Healing Environment (EHE) program published "Improving Environments for Care at End of Life" on lessons from eight pilot sites (Waller et al. 2008). Another report published on summary of evaluation findings by the King's Fund EHE (Aurthur et al. 2010). Among the ten articles, two are literature reviews (Brereton et al. 2011; and Rigby et al. 2010). Anderson (2007) studied patients' room design in palliative care unit. Two studies focused on environmental factors of end-of-life care at intensive care units (Fridh et al. 2007; Fridh et al. 2009). Silver (2004) focused on healing environments in end-of-life care. Tan et al. (2005) researched hospice environment on patient spiritual expression. Pease & Finlay (2002) focused on preference of single vs shared accommodation. Rowlands and Noble (2008) studied environmental impact and ward design. Kayser-Jones et al. (2003) identified physical environment is one of the three factors that influence end-of-life care in nursing homes. The dissertation by Swenson (2009) examined the designated hospice rooms in nursing home facilities and dissertation by Sargent (2012) explored design through relationship-centered end-of-life care.

A significant amount of studies focused on quality of care with different goals: quality of life in palliative care units (Cohen et al. 2001), quality of life for cancer patients (Cohen & Leis 2002), non-pharmacological caregiving activities (Lindqvist et al. 2012), quality of spiritual care (Puchalski et al. 2009), views on dignity (Franklin et al. 2006), influencing forces of care (Wilson & Daley 1998). Kayser-Jones et al. (2005) suggested a model hospice unit with three factors; care, community, and compassion. Seven studies focused on patients' perception and dying experience: Chinese patients' dying experience in nursing home (Chan & Kayser-Jones 2005), experience of living-dying of black and white older adults (Engle et al. 1998), ways of relating to death (Ternstedt & Franklin 2006), minority and non-minority perspectives on what is a "good death" (Tong et al. 2003), physical and psychosocial suffering in the dying process (Schroepfer 2007), and cancer patients' experience towards death (Larkin et al. 2007; and Ryan 2005).

Family perception on hospice care has examined by ten studies with different objectives: identification of factors that influence quality of end-of-life care (Heyland et al. 2006; Russell et al. 2008; Stajduhar et al. 2011), end-of-life care in hospital (Hawker et al. 2006; Spichiger 2008), and end-of-life care in nursing home (Kaarbo 2010; Munn & Zimmerman 2006; Vohra et al. 2004; Vohra et al. 2006; Wilson & Daley 1999). Staffs' perspective on hospice care has studied by Brazil et al. (2004) and Evans et al. (2006). Dissertation by Nakashima (2002) investigated the psychosocial and spiritual well-being of older adults at end-of-life.

3.0 ANALYSIS & FINDINGS

This stage considered extraction of data from these 48 literatures onto a standard template (matrix) for comparison and analysis. Data analysis considered coding and thematic development. For analysis, this study used preset themes (e.g. safety, autonomy, functionality) during extracting data and also opens to identify the new themes. The study has identified eleven Therapeutic Goals (TGs) for hospice environment:

1. *Provide continuity of self*
2. *Provision of access to nature*
3. *Provision of privacy*
4. *Facilitate social interaction*
5. *Maximize safety & security*
6. *Provision of autonomy*
7. *Regulate stimulation*
8. *Provision of spiritual care*
9. *Maximize support for staff*
10. *Provide family accommodation*
11. *Provide support after death*

As this list illustrates, many dimensions are consistent with the aging and environment literature (e.g. safety & security, stimulation), but others emerge as particularly salient in the hospice care environment, such as spiritual care or support after death. Even where the environmental dimensions are consistent, the meanings of those dimensions are considered somewhat differently due to the very specific needs surrounding the dying experience. The first eight dimensions have direct influence on patients' experience of hospice care environment, and the last three goals have indirect influence on patients' experience (e.g. support for staff). Due to the space limitations, this paper limits its discussion to the first eight therapeutic goals which are directly related to the wellbeing of the patients and their experience. Table-1 shows the relationship of each citation to specific environmental dimensions which emerged as common through the thematic analysis of the full set of literature.

Table 1: Matrix of Literatures and Therapeutic Goals

Literature (Author, Year)	Continuity	Nature	Privacy	Social	Safety	Autonomy	Stimulation	Spiritual
Anderson 2008	•	•	•	•		•	•	
Arthur et al. 2010								•
Brazil et al. 2004			•	•	•	•	•	•
Brereton et al. 2011	•	•	•	•	•	•		
Chan & Kayser-Jones 2005								•
Cohen et al. 2001	•		•	•		•	•	•
Cohen & Leis 2002		•	•	•		•		•
Department of Health and Children 2005	•	•	•	•	•	•	•	•
Engle et al. 1998				•				•
Evans et al. 2006	•	•		•	•			
Franklin et al. 2006		•		•			•	
Fridh et al. 2007			•	•				
Fridh et al. 2009			•	•				
Hawker et al. 2006	•			•		•		
Heyland et al. 2006				•				
Hospice Friendly Hospitals 2010				•				•
Hospice Unit Generic Brief 2000	•	•	•	•	•	•	•	•
Kaarbo 2010				•	•			
Kayser-Jones et al. 2003				•		•		•
Kayser-Jones et al. 2005	•			•				
Larkin 2007	•		•	•	•			
Lindqvist et al. 2012	•	•		•	•	•	•	•
Moorhouse 2006	•	•	•	•	•	•	•	•
Munn & Zimmerman 2006	•			•				
Nakashima 2002	•	•		•				•
NHS Estates 2005	•	•	•	•		•	•	•
Pease & Finlay 2002			•	•				
Puchalski et al. 2009								•
Rigbi et al. 2009	•		•	•				•
Rowlands & Noble 2008		•	•	•				
Russell et al. 2008							•	
Ryan 2005		•		•				•
Sargent, 2012	•	•	•	•	•	•	•	•
Schroepfer 2007				•				
Silver 2004	•			•		•	•	•
Spichiger 2008	•			•		•		
Stajduhar et al. 2011			•		•	•	•	
Swenson 2009	•	•	•	•		•		
Tan et al. 2005				•				•
Ternstedt & Franklin 2006	•			•				
Tong et al. 2003	•			•				•
Verderber & Refuerzo 2006	•	•	•	•	•	•	•	•
Vohra et al. 2004			•	•				
Vohra et al. 2006			•	•		•		•
Waller et al. 2008	•	•	•	•		•	•	•
Warpole 2009	•	•	•	•		•	•	•
Wilson & Daley 1999			•					•
Wilson & Daley 1998			•					•

The next section will discuss each therapeutic goal, the definition of each goal, and highlight the evidence suggestive of the appropriateness of this goal.

Therapeutic Goal – 1: Provide Continuity of Self

Definition: Environmental characteristics that help preserve or support patients' past activities, preferences and awareness.

Patients experience complex emotion, a sense of instability, and impermanence during the transition towards death (Department of Health and Children 2005; Larkin et al. 2007). Lack of familiarity and disorientation with the surrounding environment influences patients' emotions, as well as their quality of life (Nakashima 2002; Cohen et al. 2001; Brereton et al. 2011; Rigbi et al. 2009; Worpole 2009; Hawker et al. 2006). Hospice environment should offer a place where the shifting boundaries of home could be re-created to achieve a meaningful surrounding and to ease transition from home to institution (Larkin et al. 2007). The creation of a domestic or home-like environment is the most desirable characteristic for dying patients to achieve their continuity of self (Swenson 2009; Tong et al. 2003; Rijbi et al. 2009; Brereton et al. 2011; Larkin et al. 2007; Moorhouse 2006; Anderson 2008; Verderber & Refuerzo 2006; Evans et al. 2006; Kayser-Jones et al. 2005; Ternestedt & Franklin 2006; Munn & Zimmerman 2006; Cohen et al. 2001; Silver 2004).

Therapeutic Goal – 2: Provision of Access to Nature

Definition: Environmental characteristics that provide opportunities for visual and physical access to nature.

Having a connection with the outdoor nature is a significant criterion for hospice care; nature is conjectured to improve patients' mind, spirit, comfort and satisfaction (Rowlands & Noble 2008; Evans et al. 2006; Nakashima 2002; Cohen & Leis 2002; Brereton et al. 2011; Worpole 2009; Franklin et al. 2006). Dying patients typically spend increasing amounts of time indoors and become increasingly confined in a limited space (Nakashima 2002). If conditions allow, patients should access an outdoor garden or veranda, but certainly should possess a view of the natural landscape through a window; a view to nature can enhance patients' positive feelings, reduce fear and anxiety, can help to reduce pain, and maintain a calm state of mind (Swenson 2009; Moorhouse 2006; Verderber & Refuerzo 2006; Nakashima 2002; Rowlands & Noble 2008; Cohen & Leis 2002; Ryan 2005; Diette et al. 2003). Natural light is important in feeling of well-being (Anderson 2008) and fresh air ameliorates the indoor air toxicity and lessens the controlled feeling of a 24/7 air-conditioned environment (Verderber & Refuerzo 2006). Hospice environment should provide the opportunities for visual and physical access to nature.

Therapeutic Goal – 3: Provision of Privacy

Definition: Environmental characteristics that facilitate patients' choices in various levels of privacy through regulation of visual and auditory stimuli.

For dying persons, privacy is particularly salient to the dignity, independence, quality of life, and the emotional well-being (Hospice unit generic brief 2000; Moorhouse 2006; Brereton et al. 2011; Rijbi et al. 2009; Stajduhar et al. 2011; Sargent 2012; Department of Health and Children 2005; Brereton et al. 2011; Cohen et al. 2001; Swenson 2009; Cohen & Leis 2002; NHS Estates 2005; Brazil et al. 2004; Vohra et al. 2004). Lack of privacy due to the presence of a roommate and excessive noise often creates concerns (Vohra et al. 2006; Cohen et al. 2001).

Therapeutic Goal – 4: Facilitate Social Interaction

Definition: Environmental characteristics that facilitate and enable meaningful interaction between patients with staff, their family and other patients.

Presence of others, especially the physical and emotional proximity to loved ones during the dying experience is one of the key themes of a good death; it improves patients' social life and lessens the feeling of loneliness (Tong et al. 2003; Brereton et al. 2011; Evans et al. 2006; Hawker et al. 2006; Fridh et al. 2007; Brazil et al. 2004; Cohen & Leis 2002; Rijbi et al. 2010; Moorhouse 2006). To facilitate patients' social life, accommodation of family and visitors has emphasized (Munn & Zimmerman 2006; Ryan 2005; Spichiger 2008; Tan et al. 2005; Vohra et al. 2004; Ternestedt & Franklin 2006; Silver 2004; Vohra et al. 2006; Hawker et al. 2006; Swenson 2009; Moorhouse 2006; Hospice Friendly Hospice 2010; Nakashima 2002; Franklin et al. 2006). Some studies found patients get benefit interacting with other patients, it offers them self-reflection, mutual empathy, support, and companionship of this lonely journey (Munn & Zimmerman 2006; Cohen et al. 2001; Rowlands & Noble 2008; Rijbi et al. 2010; Anderson 2008; Larkin et al. 2007; Pease & Finlay 2002; Engle et al. 1998).

Therapeutic Goal – 5: *Maximize Safety & Security*

Definition: Environmental characteristics that maximize patient safety and security of self.

Safety and security is one of the prime issues of any healthcare facility, and there is a significant amount of research that has suggested in-depth design considerations related with safety and security of hospice care environment for patients: accessibility (by disable persons), fire safety codes, protection from theft & vandalism, protection from fall or slip, infection control, etc. (Department of Health and Children 2005; Moorhouse 2006; Verderber & Refuerzo 2006; Stajduhar et al. 2011; Brereton et al. 2011; Evans et al. 2006; Lindqvist et al. 2012; Larkin et al. 2007; Kaarbo 2010; Hospice unit generic brief 2000).

Therapeutic Goal – 6: *Provision of Autonomy*

Definition: Environmental characteristics that enable patients to exercise choice and personal preference about their environment and everyday life.

Humans need a sense of control and losing this can lead to depression and other serious problems; having personal control over the ambient environment (lighting, noise, temperature), communication (phone, nurse calling system) and daily routine (food, personal hygiene, sleep, recreation, music, or family visit), is one of the key considerations before death (Cohen & Leis 2002; Swenson 2009; Silver 2004; Lindqvist et al. 2012; Department of Health & Children 2005; NHS Estates 2005; Tan et al. 2005; Anderson 2008). It is significant to understand the patient's wishes and allow exploration of choices (Lindqvist et al. 2012).

Therapeutic Goal – 7: *Regulate Stimulation and Support Therapies*

Definition: Environmental characteristics that contribute to an appropriate quantity and quality of sensory experience, and support palliative therapies.

Sensory stimulation offers therapeutic treatment for pain, depression and many other symptoms, which are basic criteria of palliative care (Department of Health & Children 2005). Different types of sensory therapies (music, aroma, art, massage, spa/hydro, multi-sensory, etc.) are increasingly used in hospice or palliative care to improve patient's quality of life (Department of Health & Children 2005; Russell et al. 2008; Brazil et al. 2004). Environmental factors can influence patients' sensory experience; a meaningful view improves stress and reduces pain, color can affect mood, exposure to daylight reduces depression and eases pain, artwork (e.g. paintings, sculptures, water features) has multiple benefit (e.g. art representing nature evokes positive response), and water features have a relaxing effect (Verderber & Refuerzo 2006; Moorhouse 2006; Department of Health & Children 2005).

Therapeutic Goal – 8: *Provision of Spiritual Care*

Definition: Environmental characteristics that facilitate opportunities for patients' spiritual care; religious, philosophical, existential, and personal beliefs, values, practices, and preferences.

Spiritual care is a fundamental component of hospice care to support patients' personal striving for health, wholeness, comfort, and meaning of life (Hospice Unit Generic Brief 2000; Brazil 2004; Puchalski et al. 2009; Department of Health & Children 2005; Tong et al. 2003; Rigbi et al. 2009; Vohra et al. 2006; Cohen & Leis 2002; Cohen et al. 2001; Silver 2004; Nakashima 2002; Hospice Friendly Hospitals 2010; Ryan 2005; Engle et al.1998). Each person's definition of spirituality is individualized and may or may not include a religious preference, so spiritual care should be defined broadly, such as, meaning-oriented therapy, meditation, sacred/spiritual readings or rituals, yoga, art therapy, etc. (Puchalski et al. 2009). Hospice environment should facilitate religious or spiritual rituals or practices as desired by patient and family, especially at the time of death (Kayser-Jones et al. 2005).

CONCLUSION

This research engaged an exhaustive and systematic literature review in order to distill the salient environmental dimensions and subsequently, the therapeutic goals the hospice literature suggests are essential to promote in the hospice environments. These eight therapeutic goals can provide a sense of direction for planning and applying design skills more effectively and in greater concordance with the best practices of hospice care. We believe such lateral theoretical connections enable improvement in management procedures and the articulation of user requirements.

The study has numerous limitations and should be considered an initial effort at establishing this common language for connecting organizational and physical design decisions in a sympathetic and mutually reinforcing fashion. First we limited discussion to the first eight therapeutic goals solely due to the limitations

of space, and therein make no value judgment regarding the importance of the last three therapeutic goals that were not discussed. Second, this study has also identified the design criteria for each therapeutic goal which are also not presented due to space limitations. Third, the literature review was conducted in such a way that it did not consider the conference proceedings relevant to hospice or palliative care which may contain very meaningful insight to this question. Fourth, the interpretation was conducted and limited to two researchers which did engage in peer examination and a code-recode procedure, the study could be enhanced through further expert validation. This could be done, for instance, through utilization of the Delphi Method to obtain opinions about these therapeutic goals from a multidisciplinary experts' panel.

We believe that these eight therapeutic goals provide a useful point of departure in which to engage in effective, systemic place making. While much research focuses on the nexus amongst staff, families and patients, the physical environment is a palpable, albeit silent partner in any care milieu. Further work in this trajectory ought to include further in-depth literature review in regard to each specific therapeutic goal to identify more in-depth criteria by referencing relevant information developed in related care domains (e.g. cancer care). The development of an environmental assessment instrument organized according to these therapeutic goals would be informative to both assess existing environments but also to inform design decision-making. As our understanding of hospice care advances, we believe that these therapeutic goals can inform the creation of better hospice environments and thereby more dignified dying experiences for patients, their families and caregivers.

REFERENCES

- Anderson D. 2007. The Palliative Care Unit: Does Room Design Matter? *UTMJ*, 84(3):183-189.
- Arthur A, Wilson E, Hale J, et al. 2010. *Environments for care at end of life: evaluation of the King's Fund Enhancing the Healing Environment Programme*. Executive Summary, University of Nottingham, UK.
- Brazil K, McAiney C, Caron-O'Brien M, et al. 2004. Quality End-of-Life Care in Long-Term Care Facilities: Service Providers' Perspective. *Journal of Palliative Care*, 20(2): 85-92.
- Brereton L, Gardiner C, Gott M, et al. 2011. The Hospital Environment for End of Life Care of Older Adults and their Families: An Integrative Review. *Journal of Advanced Nursing*, 981-993.
- Chan J, Kayser-Jones J. 2005. The experience of dying for Chinese nursing home residents: cultural considerations. *Gerontol Nurs*, 31: 26.
- Cohen SR and Leis A. 2002. What determines the quality of life of terminally ill cancer patients from their own perspective? *Journal of Palliative Care*, 18 (1): 48.
- Cohen SR, Boston P, Mount BM, et al. 2001. Changes in quality of life following admission to palliative care units. *Palliative Medicine*, 15: 363–371.
- Cohen U and Weisman G. 1991. *Holding onto Home: Designing Environments for People with Dementia*. Baltimore: John Hopkins University Press.
- Department of Health and Children. 2005. *Design Guidelines for Specialists Palliative Care Settings*, Dublin.
- Engle VF, Fox-Hill E, Graney MJ. 1998. The experience of living-dying in a nursing home: self-reports of black and white older adults. *J Am Geriat Soc*, 46: 1091–1096.
- Evans WG, Cutson TM, Steinhauer KE, et al. 2006. Is There No Place Like Home? Caregivers Recall Reasons for and Experience upon Transfer from Home Hospice to Inpatient Facilities. *Journal of Palliative Medicine*, 9(1): 100-110.
- Franklin L-L, Ternstedt B-M, Nordenfelt L. 2006. Views on dignity of elderly nursing home residents. *Nurs Ethics*, 13: 130–146.
- Fridh I, Forsberg A, and Bergbom I. 2007. End-of-life care in intensive care units – family routines and environmental factors. *Scand J Caring Sci*, 21; 25–31.
- Fridh I., Forsberg A.&Bergbom I. 2009. Close relatives' experiences of caring and of the physical environment when a loved one dies in an ICU. *Intensive and Critical Care Nursing* 25(3), 111–119.
- Hawker S, Kerr C, Payne S, et al. 2006. End-of-life care in community hospitals: the perceptions of bereaved family members. *Palliat Med*, 20: 541–547.
- Hawker S, Payne S, Kerr C, et al. 2002. Appraising the evidence: reviewing disparate data systematically. *Qualitat Health Res*, 12: 1284–1299.
- Heyland DK, Dodek P, Ricker G, et al. 2006. What matters most in end-of-life care: perceptions of seriously ill patients and their family members. *CMAJ*, 174:O1–O9.
- Hospice Friendly Hospitals. 2010a. *Quality Standards for End-of-Life Care in Hospitals: Making end-of-life care central to hospital care*, Dublin: The Irish Hospice Foundation.
- Kaarbo E. 2011. End-of-life care in two Norwegian nursing homes: family perceptions. *J Clin Nurs*. 20(7-8):1125-32.
- Kayser-Jones J, Chan J, Kris A. 2005. A model long-term care hospice unit: Care, community, and compassion. *Geriat Nurs*, 26: 16.
- Kayser-Jones J, Schell E, Lyons W, et al. 2003. Factors that influence end-of-life care in nursing homes: the physical environment, inadequate staffing, and lack of supervision. *Gerontologist*, 43(2):76-84.
- Larkin P, Dierckx de Casterle B, Schotsmans P. 2007. Transition towards end of life in palliative care: its meaning for advanced cancer patients in Europe. *J Palliat Care*, 23: 69–79.

- Lawton MP. 1983. Environment and Other Determinants of Well-Being in Older People. *The Gerontologist*, 23 (4):349-357.
- Lawton MP, Weisman G, Sloane P et al. 2000. Professional Environmental Assessment Procedure for special care units for elders with dementing illness and its relationship to the Therapeutic Environment Screening Schedule. *Alzheimer Dis Assoc Disord*, 14(1): 28-38.
- Lawton MP, Kleban MH, Rajagopal D, et al. 1992. Dimensions of affective experience in three age groups. *Psychology and Aging*, 7(2): 171-184.
- Lindqvist O, Tishelman C, Lundh, HC, et al. 2012. Complexity in non-pharmacological caregiving activities at the end of life: an international qualitative study. *PLoS Med*, 9(2).
- Moher D, Liberati A, Tetzlaff J, et al. 2009. Preferred reporting items for systematic reviews and meta-analyses: the PRISMA statement. *British Medical Journal*, 339, 332–339.
- Moorhouse T. 2006. *Hospice Design Manual for in-Patient Facilities*. Hospice Education Institute, Maine, USA.
- Munn J, Zimmerman S. 2006. A good death for residents of long-term care: family members speak. *J Social Work End-of-Life Palliat Care*, 2:45–59.
- Nakashima M. 2002. *A qualitative inquiry into the psychosocial and spiritual well-being of older adults at the end of life*. ProQuest Dissertations and Theses (PQDT).
- NHS Estates. 2005. *Improving the Patient Experience. A place to die with dignity: creating a supportive environment*. Leeds: Design Brief Working Group, NHS Estates.
- Pease NJF and Finlay IG. 2002. Do patients and their relatives prefer single cubicles or shared wards? *Palliative Medicine*, 16: 445-446.
- Puchalski C, Ferrell B, Virani R, et al. 2009. Improving the Quality of Spiritual Care as a Dimension of Palliative Care: The Report of the Consensus Conference. *Journal of Palliative Medicine*, 12 (10).
- Rigby J, Payne S, and Froggatt K. 2010. Review: What evidence is there about the specific environmental needs of older people who are near the end of life and are cared for in hospices or similar institutions? A literature review. *Palliat Med*, 24(3) 268–285.
- Rowlands J and Noble S. 2008. How does the environment impact on the quality of life of advanced cancer patients? A qualitative study with implications for ward design. *Palliative Medicine*, 22: 768–774.
- Russell C, Middleton H, Shanley C. 2008. Dying with dementia: the views of family caregivers about quality of life. *Australas J Ageing*, 27(2):89-92.
- Ryan PY. 2005. Approaching death: a phenomenologic study of five older adults with advanced cancer. *Oncol Nurs Forum*, 32: 1101–1108.
- Sargent AC. 2012. *Living While Dying: An Exploration of Design through Relationship-Centered End-Of-Life Care*. ProQuest Dissertations & Thesis.
- Schroepfer TA. 2007. Critical Events in the Dying Process: The Potential for Physical and Psychosocial Suffering. *Journal of Palliative Medicine*, 10 (1).
- Silver S. 2004. Optimal Healing Environments in End-of-Life Care and Beyond. *The Journal of Alternative and Complementary Medicine*, 10 (1): S-201-S-209.
- Spichiger E. 2008. Living with terminal illness: patient and family experiences of hospital end-of-life care. *Int J Palliat Nurs*; 14: 220–228.
- Stajduhar KI, Funk L, Cohen SR, et al. 2011. Bereaved Family Members' Assessments of the Quality of End-of-Life Care: What is important? *Journal of Palliative Care*, 27(4): 261.
- Swenson DL. 2009. *Designated hospice rooms in nursing homes: A new model of end-of-life care*. University of Missouri - Columbia, ProQuest, UMI Dissertations Publishing.
- Tan H, Braunack-Mayer A, Beilby J. 2005. The impact of the hospice environment on patient spiritual expression. *Oncol Nurs Forum*, 32: 1049–1055.
- Ternstedt B, Franklin L. 2006. Ways of relating to death: views of older people resident in nursing homes. *Int J Palliat Nurs*, 12: 334–340.
- Tong E, McGraw SA, Dobihal E, et al. 2003. What is a good death? Minority and non-minority perspectives. *Journal of Palliative Care*, 19 (3): 168.
- Verderber S & Refuerzo BJ. 2006. *Innovations in Hospice Architecture*. Taylor & Francis.
- Victoria Government Department of Human Services. 2000. *Hospice Unit Generic Brief*. The Aged, Community and Mental Health Division, Melbourne, Australia:
- Vohra JU, Brazil K, Hanna S, Abelson J. 2004. Family perceptions of end-of-life care in long-term care facilities. *J Palliat Care*, 20: 297–302
- Vohra JU, Brazil K, Szala-Meneok K. 2006. The Last Word: Family Members' Descriptions of End-of-Life Care in Long-Term Care Facilities. *Journal of Palliative Care*, 22(1): 33.
- Waller S, Dewar S, Masterson A, et al. 2008. *Improving Environments for Care at End of Life: Lessons from Eight UK Pilot Sites*. King's Fund, London.
- Wilson SA, Daley BJ. 1998. Attachment/detachment: forces influencing care of the dying in long-term care. *J Palliat Med*, 1: 21.
- Wilson SA, Daley BJ. 1999. Family perspectives on dying in long-term care settings. *J Gerontol Nurs*, 25: 19–25.
- Worpole K. 2009. *Modern Hospice Design*. Routledge, Taylor & Francis group.

Urban healthcare

Kevin Moore¹, Christian Dagg¹

¹Auburn University, Auburn, AL

ABSTRACT: Healthcare facilities have the potential to be active urban centers. They can be the generators of urban density and collect new forms of public space within their gravity, offering themselves up to the public as a new type of civic building. In 2013, students and faculty working in an undergraduate design studio developed schemes for an urban healthcare facility to be located in Birmingham, AL. In the past ten years, this city has dramatically reshaped its downtown by reclaiming industrial property as venues for recreation, exercise and sporting events. Medical facilities have a major influence in this rapidly changing district, and they act as catalysts for attracting other facilities and services. Here, the unique potential of an ongoing downtown revitalization at the edge of an influential medical district guides a specific intersection of design and health.

The studio proposed a “Super Clinic,” not a hospital but a new type of facility that anticipates important changes in our current healthcare system. Developed with input from a healthcare architect, the program addresses equitable access to healthcare. While developing options for this new typology, invited practitioners helped students adjust projects to practical constraints such as programmatic appropriateness, code compliance and structural efficiency. Case studies were assembled and adapted to Birmingham, and the results help position the multi-specialist clinic as an increasingly important civic institution. Because scales range from civic exteriors to individual exam rooms, the Super Clinic suggests numerous urban responses from street walls to civic courtyards to separate pavilions. More than 50 students participated in this studio, and the range of proposals can be categorized into nine types that are inherently mixed-use. Broadly categorized, the proposals prove a range of practical and suggestive options for urban healthcare.

KEYWORDS: Architecture, Healthcare, Mixed-use, Urban Design

INTRODUCTION

In the past 10 years, Birmingham—“The Magic City”—has begun a dramatic renaissance. Simultaneously an abandoned industrial city and a vital economic center, Birmingham is actively reshaping its downtown core. Medical facilities are a major economic influence in the rapidly changing south side, with Children’s Hospital and the University of Alabama Birmingham (UAB) School of Medicine acting as catalysts for attracting other facilities and services. Railroad Reservation Park and Regions Field—the Barons Baseball Stadium—are wildly successful new attractions. This combination of activities, healthcare and public recreation is a positive revitalization tool. A drastic remaking of the district is now possible. Originally home to warehouses and distribution centers, the area is transforming into a mixed-use neighborhood connecting UAB to downtown. Developers have broken ground on housing, and although they have resisted adding commercial or retail, the first grocery store in the area is scheduled to begin construction within the year. With large tracts of land owned by UAB and Children’s Hospital, healthcare could add an additional mixed-use component to the district. Traditionally understood as hermetic building types, inpatient and outpatient facilities can be reconceived as models for mixed-use, some supporting 24-hour activity.

The Urban Healthcare studio was run as a 20-week comprehensive design course in Fall 2013 and Spring 2014 amidst significant changes to healthcare in Birmingham. First, the federal Patient Protection and Affordable Care Act began initial enrollment in October 2013. In January of that year, however, Jefferson County reduced services at Cooper Green Mercy Hospital, a locally subsidized full service hospital for the poor and near-poor. As a result, 35,000 patients were left without primary care. Dr. Max Michael, Dean of the UAB School of Public Health, explained the significance to students:

You’ve got a major revolution in healthcare access [and] health insurance coverage in this country that is taking place [and] that will take place throughout, I suspect, most of your careers, and you’ve got a county that reflects exactly the kinds of things that are going on in this country—no resources, small tax base...and yet you’ve got to provide care for people.

As Dr. Michael suggests, primary care is increasingly a public health and civil rights issue. The Super Clinic was proposed in this context. We asked students to become optimistic about the ways in which the Affordable Care act will influence the design of healthcare facilities by extending the types of preventative services offered and increasing the scope of citizens with access to healthcare. The consensus is that we

are witnessing a healthcare revolution. Although the long-term implications for architecture are unclear, Birmingham is an excellent case for urban healthcare. The proposed Super Clinic adds mixed-use program on nine potential sites (Figure 1), and the choice of sites required students to analyze the district and connect healthcare architecture to a wider discussion of civic health.

Although speculative, the studio was carefully developed to anticipate practical considerations. With funding from the NCARB Prize, professionals from several overlapping fields including architecture, landscape architecture, engineering, evidence-based design and public health participated in the studio through lectures and workshops. The program was developed by Patrick Davis, FAIA, a professional healthcare architect with over 40 years of experience. The workshops helped students adjust projects to practical constraints such as floor area efficiency and travel distances for staff. Design choices were also based on current evidence-based design standards. Invited practitioners assured student work met fundamental requirements of life safety code, structural efficiency and building envelope performance. These professional standards add legitimacy to the range of options developed for the Super Clinic.

Integrating technical constraints into a studio dedicated to urban architecture is a particular pedagogical model. Cities are intensely collective endeavors, and the studio embraced the complexity of competing technical and cultural demands. As a hybrid type, healthcare also defies traditional urban models such as public institutions or housing. The Super Clinic, then, was proposed as an inclusive problem but focused on the anticipated need for multi-specialist clinics. In developing the studio, our invited practitioners encouraged us to include healthcare professionals and registered planners and landscape architects. All of these professions are committed to health, safety and welfare, and their combined impact can be understood in terms of civic health. We needed little convincing. The pedagogical goals, however, expanded the scope of the research. In studio, vibrant cities were discussed as integrated networks of people and infrastructure rather than accumulations of self-contained buildings.

In this case, Birmingham was investigated as a city defined by mixed-use, a city defined by landscape and a city defined by buildings. Students were challenged to develop an architectural response to urban healthcare, and case studies were carefully curated and adjusted to specific sites in Birmingham. More than 50 students participated in this studio, and the range of proposals can be categorized into nine types that are inherently mixed-use. Broadly categorized, the proposals prove a range of practical and suggestive options for urban healthcare

1.0 RESPONSE TO THE CITY

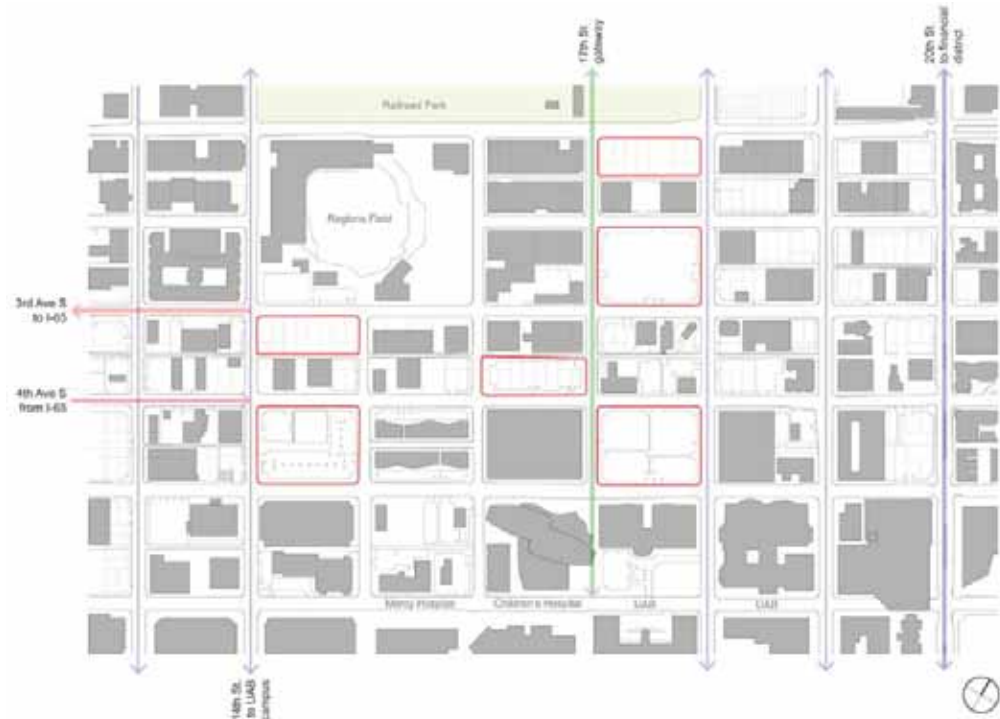

Figure 1: The Parkside district features a hierarchy of streets and avenues, forming a “weave” connecting the University of Alabama Birmingham (UAB) to the financial district. Nine potential 140’ x 400’ half block sites are denoted in red.

1.1. City defined by mixed-use

Developed as an industrial city, the center of Birmingham is a regular grid of large blocks (300' x 400') aligned to the southwest-northeast topography of Jones Valley. A major railroad corridor bisects downtown into a financial district to the north and warehouse district to the south. The studio compared a 40-block area (1/2 mile x 1/2 mile) of the warehouse district to other urban centers. The blocks compare to the residential courtyard blocks of the French Quarter in New Orleans (330' x 330') or Cerdà's Eixample in Barcelona (380' x 380'). They also compare to the large commercial blocks of River North in Chicago (220' x 300') or the Tenderloin in San Francisco (275' x 410'). In this case, the large blocks are an asset; they open options for a mix of courtyard residential, large commercial and healthcare. UAB and Children's Hospital have collected property into large full and half-block parcels. As a result, the future grain of the district will likely be coarse as opposed to the original 25' wide parcels. As steel production moved from Birmingham and the central core was systematically erased or abandoned following the 1963 civil rights events, surface parking and undefined open space overtook the neighborhood. The recent completion of Regions Field and the iconic Benjamin Russell Hospital for Children, however, points to a civic dimension anchored by healthcare and entertainment.

Surprisingly, the sparse district is clearly defined. I-65 creates a largely impenetrable western edge, and 20th street, the historic north-south boulevard, is a clear but porous edge to the east. UAB and its medical center form the southern edge of downtown at the base of the Red Mountain. The bulk of the hospitals reinforces the mountain ridge in the background; it sets a clear visual boundary from long distances. Likewise, the raised railroad corridor is an unmistakable boundary to the north. The newly opened Railroad Park, a 30-acre public park designed by Tom Leader Studio, has transformed this industrial edge into a popular destination. Anchored by Railroad Park and the UAB hospitals, the area, now named Parkside, is understandable as a distinct "imageable" district (Lynch 1960).

The streets are clearly differentiated by traffic use (Figure 1). East-west avenues, especially those that connect to I-65, carry heavy traffic. They are poised for commercial activities in sections of their 400' length. North-south streets, on the other hand, typically terminate at UAB, Railroad Park or the newly opened Regions Field. These quieter 300' blocks are favorable for walkable residential streets. East-west alleys, although slowly disappearing, reinforce this stressed grid. If maintained, the original alleys can collect trash, loading, parking and additional stormwater and limit the grain of the district to 140' x 400' half-blocks. Most importantly, Parkside is the connection between the financial district and UAB. The streets of the district form a "weave" (or zig-zag) between these established nodes.

1.2. City defined by landscape

Although the neighborhood is "imageable," it is also productively open-ended. The large blocks accommodate light industrial, commercial and residential. The streets and avenues—an 80 foot right of way—are generous but not extravagant. In anticipation of the Super Clinic, students developed district plans to expand the increasingly active streetscape. Options developed by students prove tantalizing possibilities within limits. For example, sidewalk cafes, bicycle lanes, stormwater retention, street trees, parking and three lanes of existing traffic are all options but simply do not fit in a single right of way (Fig. 2).

Reconfiguring streets is often impossible, but the Children's Hospital and UAB are exerting their influence. The 17th Street Redevelopment is an example of a streetscape that will transform loading for warehouses into a walkable mixed-use corridor. This corridor connects Railroad Park to Children's Hospital and its properties along 17th Street, "establishing civic identity, and attracting new business developments, patrons and public activity" (Giattina Aycok 2009, 44). Driving and parking lanes are narrowed to extend sidewalks and accommodate street trees including an allée to the east (Fig. 2). Conceived as a "gateway" to Railroad Park, the streetscape continues the aesthetic tradition of European and American "great streets" (Jacobs 1993). Buildings are traditional background: "buildings maintain a consistent edge at property lines" with "awnings to provide pedestrian scale and cover" (Giattina Aycok 2009, 44).



Figure 2: 17th Street Redevelopment and sample streetscapes developed by students. Controlling multiple full and half block parcels in the district, the University of Alabama Birmingham (UAB) and Children's Hospital have begun to transform select streets from loading for warehouses to walkable mixed-use corridors.

1.3. City defined by buildings

With clear edges and paths, what is missing in the district is activity structured by buildings. In this case, healthcare provides a practical model for mixed-use infill. However, if large blocks limit social and economic diversity, large parcels exacerbate this condition (Jacobs 1961, 179-186). This has been the traditional complaint of medical districts: big buildings on bigger blocks. This is true in Birmingham, but the hospitals are limited to a perceivable edge. In Parkside, however, the high percentage of open space also means the district is spectacularly permeable. Glimpses of distant infrastructural and landscape edges persist throughout. The existing quality of the neighborhood is fascinating enough to resist a return to a traditional urban wall defined by consistent facades. Students discovered this nuance as they assembled case studies and tested them as options for a new “Super Clinic.”

2.0 RESPONSE TO THE PROGRAM

2.1. Healthcare case studies

The Super Clinic is a 133,000 square feet hybrid program including primary ambulatory care, mental health, medical oncology, public education and 50 skilled nursing rooms. The program assumes an increase in the number of newly insured patients, an increase in preventative education and an increase in procedures that do not require a physician’s attention. The combination of outpatient care, public space and long-term skilled nursing is an exemplary vehicle to evaluate primary objectives for urban architecture including the conflicting pressures of collective and individual access and identity. The goal was to connect the design of a healthcare building to a wider discussion of civic health including downtown revitalization and walkable mixed-use neighborhoods. Students were encouraged to conceive of the clinic as a civic endeavor—a well executed piece of urban architecture that provides public amenities as well as a physical and spatial urban presence.

In developing the Super Clinic, the studio assembled pertinent case studies. Case studies including floor plans are now widely published. *Architectural Record*, for example, publishes a yearly “Building Types Study” on healthcare (“Building Types Study” 2013). Several recent books including *Innovations in Hospital Architecture* by Stephen Verderber also rely on the case study method (Verderber 2010). These publications present a range of options for hospitals that are also intriguing urban and civic models. Clinics are underrepresented in the literature, and a significant outcome of the studio is the development of options for multi-specialist clinics based on published hospital case studies.

The case studies can be broadly categorized by corridor type and room type. Single and double-loaded housing types have been adapted for hospitals, especially in Europe. The “looped corridor,” with an island of internal support spaces, is more typical in North America. While limiting daylighting, looped corridors increase floor area efficiency, segregate public and services corridors, remove dead-end corridors and optimize nurse to patient interaction. Recent evidence-based design has focused on the patient room, and several practical options have emerged. Toilet rooms can be located on the exterior—“outboard”—or on the corridor—“inboard”—balancing visibility for medical staff with privacy for patients and families. Patient rooms can be “mirrored” to consolidate plumbing or “same-handed” in an attempt to reduce staff errors (Cahnman 2010). These options—looped, single and double-loaded corridors and inboard, outboard, mirrored and same-handed rooms—are identified for each case study (Fig. 3).

Less evidence exists to guide schematic decisions for clinics and skilled nursing; research dollars have simply not focused on these problems. However, the Mayo Clinic Center for Innovation recently developed a “Jack and Jill” clinic room to separate the exam space from the conversation space without significant changes to spatial layout (Mayo Clinic 2013). Designed for quick, efficient visits, most clinics rely on large lease spans with internal rooms. Daylighting is reserved for lobbies and waiting areas. Our invited expert on evidence-based design, Dr. Sheila Bosch, stressed the importance of an inspiring healthcare facility for patients, families and staff. For Dr. Bosch, the creation of captivating places is a professional obligation despite inconclusive scientific evidence of direct palliative benefits. Options for thoughtful healthcare architecture were guided by carefully curated case studies that represent a range of evidence-based design standards. Many case studies also add an engaging variety to the city through porous boundaries including courtyards, gardens, porches and partly defined open spaces. These strategies were redeployed by students to propose the Super Clinic as an active mixed-use urban building.

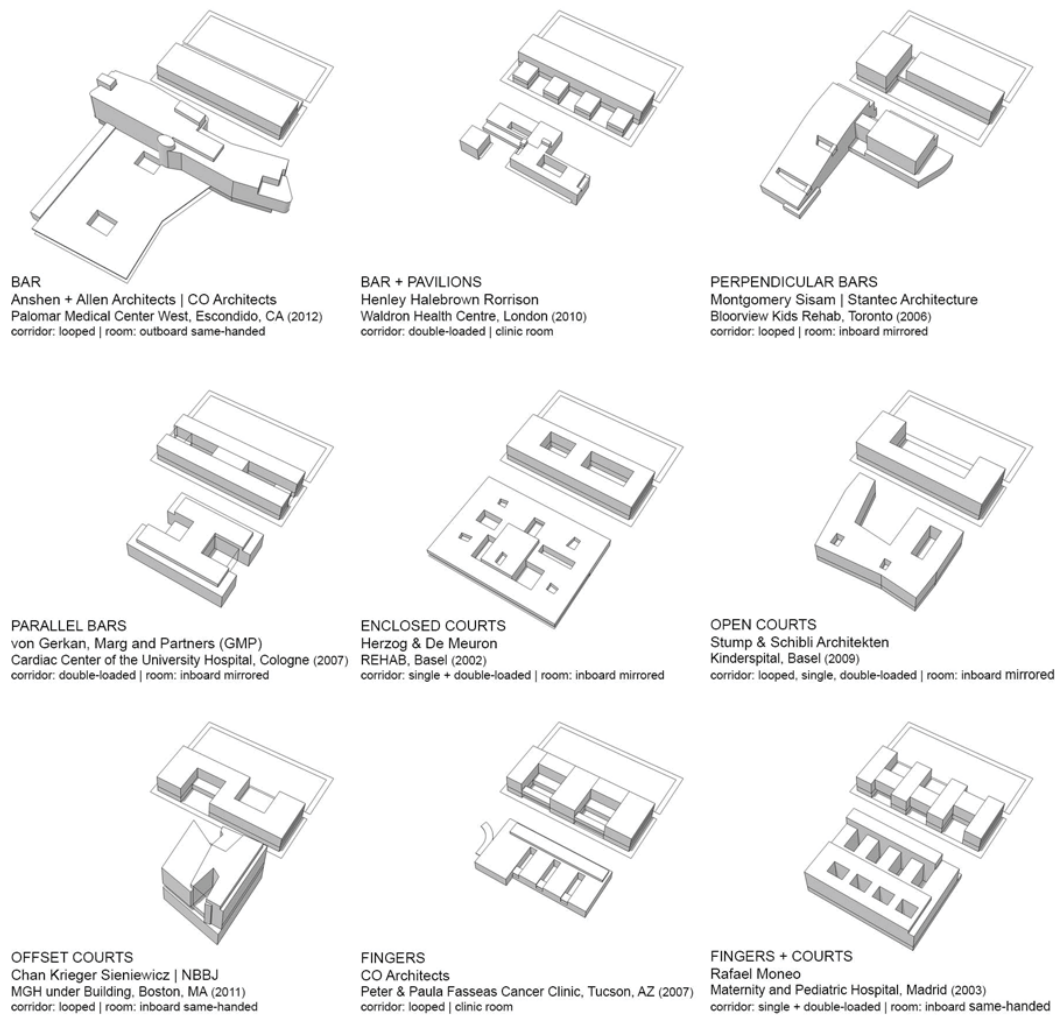

Figure 3: Healthcare case studies and Birmingham "Super Clinic" types as developed by students. Over 50 projects can each be described as one of these types, proving a range of options for healthcare as mixed-use urban buildings.

2.2. Super clinic types

The projects developed by students prove the case studies—mostly hospitals—can be adapted as a clinic for a Birmingham city block—specifically a 140' x 400' half block (Fig. 3). Students developed schemes with the help of architect practitioners integrated into the curriculum. Workshops assured student work met fundamental requirements of life safety code, structural efficiency and building envelope performance.

If a new type, the Super Clinic is amazingly familiar. Skilled nursing rooms can be arranged similarly to hospital patient rooms. Some arrangements are not dissimilar to housing, especially single and double-loaded corridors types that significantly reduce the percentage of internal rooms. Clinics are similar to procedural and diagnostic departments in hospitals. More efficient on large floorplates, clinics are also similar to a typical office lease span. On a 140' x 400' half block, floorplates are productively limited. Although the case studies vary in size, the clinic options developed by students prove they can be adjusted to anticipate compact urban healthcare. Most importantly, there is not a single way to occupy the block but a number of suggestive types.

With a range of practical options, the program of clinic and skilled nursing does not determine an urban response; it is a negotiation between the two. In this case, the urban and civic dimension is at least as important as programmatic imperatives. Potential activity in the city informed the public interiors and demanded careful access to private outpatient clinics and skilled nursing rooms. In many cases,

architectural organization promoted interaction between the street and the interior (Fig. 5). The adjusted types also outline options for public space—from porches and atriums to squares and courtyards—suggesting healthcare should be civic structures engaged with the city.

The range of options proves a Super Clinic is good model for mixed-use and suggests unique combinations of housing, assisted living, clinic and office. If one were to design a healthcare district from the ground up, this would be a potential model: the district is imageable but open-ended, and a range of options for streetscapes and buildings are possible within productive limits. A major hurdle facing Parkside is an almost pathological need for structured and surface parking. Luckily, a 140' x 400' half block seamlessly fits parking. More provocatively, each type can accommodate parking if limited to a 60' wide flat deck with a 20' speed ramp.

Birmingham is emerging from huge changes in industrial production and racial demographics. Its fragments are haunting and compelling. In this context, the studio tested concepts of civic health as an urban experience. The studio developed a range of types—options for conceiving of civic healthcare and permeable mixed use—as a series of guidelines for future development. This research may have agency in the future of Birmingham.



Figure 4: BAR + PAVILIONS Super Clinic type developed by student Michael Lewandowski.



Figure 5: FINGERS Super Clinic type developed by student Maggie Scott.

CONCLUSION

Stan Allen provocatively suggests:

Architects seem condemned to work on the surface of the city and not its structure. This is a situation that is historically determined and unlikely to change significantly as a result of anything that the architectural profession does. But it can also be argued that architects have yet to examine the consequences of this shift. If architecture has lost its historic capacity to fix and determine the limits of urban space and territory, are architects left to work exclusively with images? (Allen 2009, 59).

Working on the surface of the city, two positions for architecture have emerged. First, surface is not superficial. In case studies such as Kinderspital Basel and the Waldron in London, graphic building envelopes invite the public to engage fast but surprising effects such as extracted holes, saturated monotone materials and “precise but vague silhouettes” (Somol 2007, 34-35). These graphic shifts in scale happily camouflage a 400’ facade into the city. Second, buildings still structure urban space, but most profoundly as a local social geography. The coarse grain of Parkside demands that buildings adjust an immediate social landscape rather than propose entirely new urban forms.

Although adjusting case studies to prove options is a traditional studio method, the choices range across these debates in architecture. This research demonstrates the urban design and presence of healthcare facilities is at least as important as programmatic organization. Typically understood as anti-urban, these building types are now more important than ever in the economic and physical health of the city. The results of the studio are more mixed-use urban buildings than programmatic systems. Because of the site specificity of architectural practice, this studio is inseparable from the location of the work, in this case Birmingham, AL. An important achieved outcome of the studio is that it has produced potential guidelines for future development in the center of this city, which include a range of options for occupying the open, abandoned city blocks. It is important to understand that buildings establish both urban and aesthetic presence as well as programmatic opportunities. The Super Clinic is optimistic about the anticipated need for multi-specialist clinics and their role as mixed-use urban buildings. An alternate prediction is that healthcare will be distributed and miniaturized through technology, requiring smaller buildings and storefronts. In either case, healthcare is a civic health and civil rights issue intimately involved in the life of any city.

ACKNOWLEDGEMENTS

The studio was funded by an award from the NCARB Prize to integrate architect practitioners into the design curriculum, and the authors would like to acknowledge the following collaborators:

licensed practitioners: Dawn Mixon Bennett, AIA; Patrick Davis, FAIA, James Scott, AIA

workshop participants: Philip Amthor, AICP; Elizabeth Barbaree-Tasker, Sheila Bosch, PhD; Jason Fondren, AICP; Matthew Leavell, RA; Lea Ann Macknally, ASLA; Max Michael, MD; Cheryl Morgan, FAIA; Shepard Stuart, PE; Dennis Tow, PE; Ben Wieseman, AICP, ASLA

final reviewers: Bob Farrow, AIA; Rayford Law, AIA; Ursula Emery McClure, AIA; Francisco Javier Rodriguez, AIA; Gregory Walker, AIA

faculty: Rebecca O'Neal Dagg, Jeffrey Collins, Scott Finn, Tarik Orgen; *graduate assistant:* Martha Merzig

Finally, the authors would like to acknowledge the students of Auburn University and the solutions they developed over the course of the 20-week studio. Broadly categorized, the projects contribute to a deeper understanding of how design offers innovation for healthcare facilities and the urban spaces they inhabit.

REFERENCES

Allen, Stan. 2009. "Notations and Diagrams." In *Practice: Architecture, Technique + Representation*, 2nd ed., 41-69. New York: Routledge.

"Building Types Study 932: Health Care." 2013. *Architectural Record*, March: 131-142.

Cahnman, Sheila F. 2010. "Key Considerations in Patient Room Design: 2010 Update." *Healthcare Design*, August 1. Accessed September 20, 2010. <http://www.healthcaredesignmagazine.com/article/key-considerations-patient-room-design-2010-update>.

Giattina Aycok Architecture Studio, Inc.. 2009. "Children's Health System 2009 Master Plan."

Jacobs, Jane. 1961. *The Death and Life of Great American Cities*. New York: Random House.

Jacobs, Allan B. 1993. *Great Streets*. Cambridge, MA: MIT Press.

Lynch, Kevin. 1960. *Image of the City*. Cambridge, MA, Technology Press.

Mayo Clinic Center for Innovation. 2013. "Jack and Jill Rooms." Last modified Oct 11. <http://www.mayo.edu/center-for-innovation/projects/jack-and-jill-rooms>.

Somol, R. E. 2007. "Green Dots 101" *Hunch* 11: 28-37.

Verderber, Stephen. 2010. *Innovations in Hospital Architecture*. New York: Routledge.

RESEARCH
IN PRACTICE

A comparative approach to map BIM workflow in US mid-size firms using BPMN and IDEF methods

Ibrahim A.I. Abdelhady¹

¹Alexandria University, Alexandria, Egypt

ABSTRACT: This paper is a part of an ongoing research that is motivated by the increasing need for business process improvement in the competitive AEC industry and Building Information Modeling (BIM) implementation. Thus, the main objective of this research is to develop an explicit and flexible Business Process Model (BPM) for midsized architectural firms that are adapting to the wide scale implementation of BIM. The BIM business process model developed through this research could serve as a reference model for restructuring many architectural firms.

The general outcome of this paper is a comparative description between two methods of mapping the existing work flow of BIM using The Business Process Modeling Notation (BPMN) and the Integration DEFinition (IDEF), as derived from expert questionnaire and two BIM case studies. The paper focuses on the Schematic Design (SD) and Design Documents (DD) phases inside mid-sized architectural firms in USA.

The first objective of this paper is to map the existing BIM business process model for midsized architectural firms, and to discuss the adapted criteria, a step to fill the research gap in the academic field. The second objective is to measure the level of interactivity between the two generated business process models and various BIM users, in order to establish an effective modeling approach to develop the existing BPM. It is highly expected that through the development and implementation of this new model, the use and functionality of BIM will be enhanced.

KEYWORDS: Building Information Modeling (BIM), Business Process Modeling Notation (BPMN), Integration DEFinition (IDEF), Schematic Design (SD), Design Documents (DD)

INTRODUCTION

Today, there is little doubt that Building Information Modeling (BIM) is a new technology that is reshaping the building industry. BIM has emerged as a useful tool for architects, engineers, and contractors in the delivery of new constructions. BIM is an innovative tool that most design and construction professionals do not currently use on a regular basis. According to the Smart Market report, in 2008, architects were the most frequent BIM users with 54% usage (McGraw-Hill 2008). However, as those professionals increase their understanding of BIM and its capabilities, BIM will likely become a part of common design and construction practices. On the other hand, BIM, like many other products in the project management software industry, currently faces significant issues and obstacles that prevent its widespread use. These issues include inappropriate adaptation strategies, old management and organizational structures, and slow software development (McGraw-Hill 2008). There arises the need for businesses to assess and rethink their existing BIM implementation processes, communication mechanisms and information flow strategies in order to fully avail themselves of the opportunities that BIM has to offer. This may involve the means to smoothly shift from existing CAD platforms, and how to find the precise changes that can prompt architectural offices to improve their existing business processes, and develop strategies that are flexible enough to incorporate BIM as it evolves.

Based on these requirements, this paper focuses on the need of mapping the "As-is" BIM implementation workflow that are currently exist in mid-sized architectural firms as they relate to how information flows, BIM related activities and the existing business processes model. For this, two case studies and several interviews were conducted. The case studies and the interviews findings helped to develop the existing business model and to identify challenges associated with BIM implementation, and the potential areas for improvement, especially those ineffective processes at the departmental boundaries.

1.0 Business Process Modeling

Business Process Modeling (BPM) is commonly a diagram representing a sequence of activities that shows sequential events, actions and links or connection points. The term 'process' can be defined based on the subjected field of interest. For example Harrington (1991) defines the term "process" as "any activity or group of activities that takes an input, adds value to it and provides output to an internal or external customer. Processes use an organization's resources to provide definitive results". Davenport (Lineberger and Marwick, 1993) states that "a process is simply a structured, measured sets of activities designed to produce a specified output for a particular customer or market". Although the Business Process Modeling has different approaches, the main approaches are the Business Process Model and Notation (BPMN), the Unified Modeling Language (UML) and Integrated Definition (IDEF) modeling. According to Dana Smith, the most common approaches that are being used in the AEC industry are the BPMN and IDEF. For a better

more elaborative definition of these approaches the next section will provide a detailed discussion (Smith and Tardif, 2009).

1.1. Business Process Model and Notation (BPMN)

Business Process Model and Notation (BPMN) is a graphical representation approach and modeling method for mapping business procedures. It is also known as Business Process Modeling Notation. This approach was first introduced by Business Process Management Initiative (BPMI), but currently it is being developed by the Object Management Group after the two organizations merged in 2005. The latest version of BPMN is 2.0, as of March 2011. This version works based on a flowcharting technique, which is very similar to activity diagrams from the Unified Modeling Language (UML). The BPMN approach is one of the most powerful languages used in representing information flow, interdependencies of roles, and sequence of activities, which helps many organizations in the building industry. A BPMN is presented in common graphical languages that bridges communication gaps and unifies graphic notation while considering the complexity of business execution languages, and particularly Business Process Execution Language (White, 2006). Moreover, the widespread adoption of the BPMN and the variety of competing standards help to unify both basic and advanced business process concepts in one diagram. Thus, many architectural/construction organizations are giving more attention to the BPMN approach (Smith and Tardif 2009). As shown in figure 1 in the Business Process Diagram, there are a number of graphical elements with which we represent a business process. Within these elements are the activities that represent the work that was carried out, the beginning and end events, which indicate the starting point and completion of the process, plus the decision elements known in BPMN as Gateways, which indicate alternatives along the way. These elements are connected by means of Sequence Lines that show the process flow.

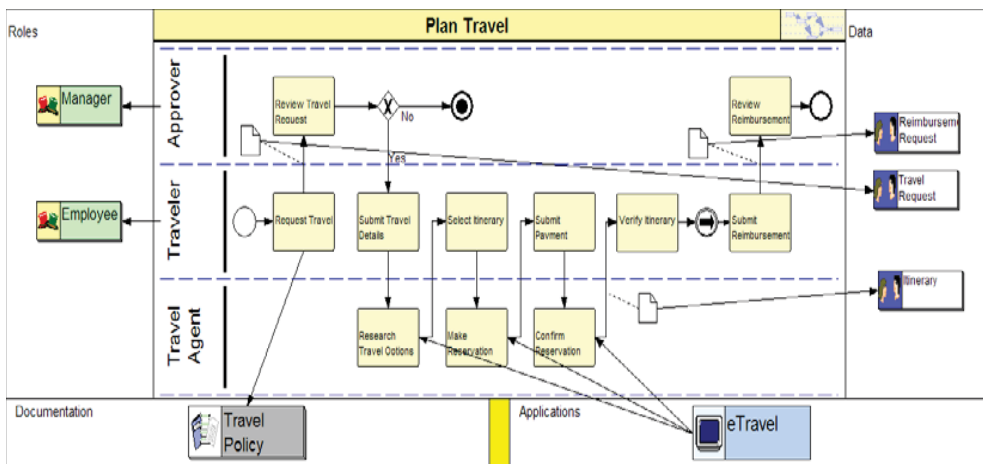

Figure 1: Business Process Model and Notation for a process with a normal flow. Source: (Sowell 2009)

1.2. The Integrated Definition (IDEF)

IDEF is a business process modeling approach that was first initiated and developed by the U.S. Air Force in the 1970s to cover a wide range of uses, from functional modeling to data simulation, object-oriented analysis-design and knowledge acquisition. As a widely used functional modeling approach for engineering purposes, this approach is being used in the architecture/construction industry as a modeling approach to map and analyze the functions and activities for the design/construction process (Savage 1996, p: 84). The Integrated Definition (IDEF) has at least fourteen versions but the most-well known and widely used of the IDEF family are IDEF0 (a functional modeling language building on SADT) and IDEF1X, which address information models and database design issues. The IDEF0 was derived from the graphic modeling language Structured Analysis and Design Technique (SADT) as developed by Douglas T. Ross and SofTech, Inc. (Ward 2009) to model the decisions, actions, and activities of an organization or system. In the architecture/construction industry, IDEF0 represents functional modeling by tracing the Inputs, Controls, Outputs and Mechanisms (ICOMs), which captures the important data flow for each activity, resulting in a hierarchical series of diagrams, and text cross-referenced to each other. Usually, the primary modeling components (activities) are represented on a diagram by boxes, and the data (inputs/outputs) that interrelate those functions is represented by arrows. The diagrammatic representation of IDEF0 methodology can be seen in Figure 2.

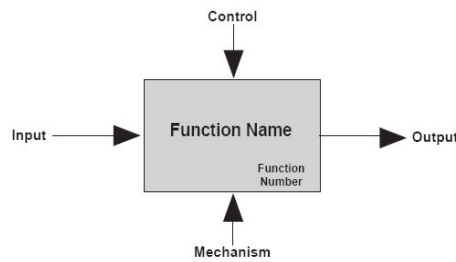

Figure 2: IDEF0 Notation Source: ([Defense.Acquisition.University 2001](#))

2.0. OVERVIEW OF RESEARCH DATA COLLECTION

Yet, this paper will provide an overview of the existing BIM (As-is) process model, which presents the communication mechanisms and data flow related to BIM inside the subjected firms using two modeling techniques, BPMN and IDEF. In order to map the existing BIM workflow, the researcher conducted two case studies and several interviews in an attempt to map those challenges for mid-size firms. For the case studies, the sampling process was initiated by gathering information about the specifications of the mid-size architectural firms in the USA. Then, the researcher selected two mid-size firms that follow the research sampling criteria. The first case study was conducted in a mid-size firm that is located in Norfolk, VA and contains 37 architects and employees, while the second firm contains 48 architects and related employees. The researchers entered both firms as an investigator after receiving Virginia Polytechnic Institute and State University (Virginia Tech) Institutional Review Board (VT IRB) approval. During case studies, the researcher observed the day-to-day operations, team interactions and communication exchanges as they relate to project design development and construction management using BIM. Moreover, the researcher conducted seventeen interviews started with one or two interviewees and then proceeded with parallel data analysis to avoid being overwhelmed by massive amounts of information, which emerged and were updated during data collection. Furthermore, the questions that arise from the first interview helped to develop and guide the adjustments for the next round of interviews (Strauss and Corbin 1998).

2.1. Types of data collection methods

The researcher adopted a dual approach to collect data, by carrying out both interviews and case studies, which helps to increase the validity and reliability of the data, as the strengths of one technique can counterbalance the weaknesses of another. Another reason to adopt this dual approach is that the case study strategy can be criticized because of the lack of measurability. Thus, the researcher applied the case study technique in this research to analyze different variables relevant to the studied phenomenon (Key, 1997). Furthermore, mapping a business process flow requires tracking and mapping of information exchange between BIM users and other various complicated activities, which have to be mapped within existing environments. So, two case studies were conducted to map BIM related process modes, however the duration of the case studies was not long enough to develop a business map for the entire BIM related activities. Thus there was a need for collecting more data using interviews to develop a complete preliminary "As-is" business process model thus another round of interviews (structured interviews) was conducted (Jan 2011- Oct 2011), where interviewees were asked to recall their roles and activities inside the targeted firms, as well as to describe the routes of information flow and how decisions are made.

On the other hand, extensive interviews (semi-structured and structured interviews) with numerous BIM stakeholders have been conducted for different reasons; to provide rich and relevant data on the research subject, and also to cover any lack of information from the case studies, to achieve the generalizability of the process model, and to share common characteristics of the mapped business model with other mid-sized architectural firms.

2.2 Interview mechanisms

Using interviews as a tactic, the researcher initially sent an email that contained an overview, targets, and expected outcomes of the research to the BIM manger in the subject firms. Interviews began with a top-down management strategy: The researcher started by interviewing stakeholders and BIM/project managers in the targeted firms, and then proceeded to the operational staff and other BIM stakeholders (Cai, 2007). At the end of the first interview, the researcher asks BIM/project managers to introduce key persons in their BIM related business process. In the first round of interviews, participants were asked to freely express their thoughts and ideas concerning BIM related issues. This data, in addition to data obtained from the case studies, were later coded and interpreted to provide sufficient information that helps to build a holistic understanding of the As-is BIM related business process model. While the second round of interviews was conducted to complete the layout of BIM related workflow.

2.3 Interviewees demographics

The interviews took place over the course of seven months from November 2010 to June 2011 with a total of 12 interviewees. Some of the interviews were conducted over the phone and the others were in personal.

The following table summarizes the interview process. The table represents participants' demographics based on their BIM activities, experience, interview types and durations.

Table 1: Interviewees Demographics

Participants	Discipline	Firm 1	Firm 2	Out of case studies Firms	Work Experience in years	Interview Mode	Interview Media	Interview Duration hh:mm:ss	Interview Rounds	
									Round 1 (BIM Issues)	Round 2 (As-is model)
Participant (1)	BIM manager	*			15	Semi-structured/ Structured	Personal	01:01:33 00:31:02	*	*
Participant (2)	BIM manager		*		10	Semi-structured/ Structured	Personal	00:47:17 00:24:52	*	*
Participant (3)	Architect	*			3	Semi-structured	Personal	00:51:50	*	
Participant (4)	Architect			*	4	Semi-structured	Personal	00:33:21	*	
Participant (5)	MEP	*			3	Semi-structured/ Structured	Phone	00:55:01 00:23:42	*	*
Participant (6)	HVAC	*			5	Semi-structured/ Structured	Phone	00:45:38 00:26:29	*	*
Participant (7)	Architect			*	3	Semi-structured	Personal	00:25:32	*	
Participant (8)	Architect			*	3	Semi-structured	Personal	00:21:41	*	
Participant (9)	Architect		*		2	Semi-structured	Personal	00:31:38	*	
Participant (10)	MEP		*		8	Semi-structured/ Structured	Personal	00:41:10 00:29:51	*	*
Participant (11)	HVAC		*		4	Semi-structured	Phone	00:55:21	*	
Participant (12)	Contractor			*	13	Semi-structured	Personal	00:24:11	*	

2.3. Case study sampling:

According to “revitinside.com” (last update: June 2, 2010) 500 of registered architectural firms are using BIM not only as the design delivery tool but also as a collaboration tool. This represents 2.5% of total the registered architectural firms in the USA in 2010. There are at least 20,000 architectural firms in the USA. Characteristics of Case studies can be identified as the following:

Firm Type: The subjected firms are mid-size architectural firms in USA. The firm should contain 5 to 50 employees organized structurally in different departments such as design, production, business development, and construction administration.

Firm Experience: The subjected firms should have variety of business services in addition to its ability to complete technically challenging projects. Also, the firm should be able to conduct simulations and comparative analysis, either environmental to measure the facility's predicted performance, or construction simulation for sequencing the construction process. Moreover, it should also have the ability to manage and produce construction documents and specifications, and to follow up the construction progress.

Project types: As previously mentioned in chapter one of this dissertation, this study focuses on mid-size to large-scale projects (commercial buildings, educational, etc.). These projects were chosen as a limit for this research for two reasons. The first one is that the number of communication issues that might typically emerge in mid-size to large scale projects is more than for small-scale projects. Secondly, adapting BIM as a new technology in contemporary architectural firms adds cost of running a new system to the overall project cost.

Firm Clients: The firm should have a broad range of clients (e.g. the government, private developers) and supervise various project types, such as industrial and civil facilities. This wide range of business patterns will provide multiple attributes in the business processes that can be found in other mid-sized architectural firms in the USA.

BIM manager: Although every organization may have different functional departments, head and CEO, it is important for the subjected firms to have a BIM manager, who is able to facilitate all the process necessary to manage BIM, understands the workflows, who has a technical knowledge of BIM applications used and also has strong communication skills.

The first subjected firm is located in Norfolk, VA and contains 37 architects and employees and a BIM manager who has a very good experience with BIM issues, helping to cover a lot of communication problems inside the firm. The subject project is the “West Virginia Medical Center”. The architectural teamwork of this project consists of at least one member to fill the following categories; shell, enclosure,

interior, site and custom objects (People work in separate tasks). The MEP team has four engineers; HVAC, fire protection, electric, and plumbing engineer, while the structural team has three engineers who are working on structural design and structural analysis. The second subjected firm contains 48 architect and employees. The subject project is the “ Medial Center in WV, USA” From both case studies it will be clearly shown that BIM could be a constraint when not implemented probably. The researchers entered both firms as an investigator from June 2010 until April 2011, after receiving Virginia Polytechnic Institute and State University Institutional Review Board (VT IRB) approval.

3.0 Mapping BIM “as-is” workflow – schematic design phase

With the aid of different data resources, including; researcher’s notes, diagrams and memos that were gathered during the case studies, in addition to the interviews that were conducted to understand BIM activities and tasks in the Schematic Design phase, the researcher was able to map BIM workflow as the following.

The workflow usually starts once the client initiates the need for the project. Usually, the client has preconceived knowledge of the project’s purpose and what benefits should be achieved. Then the process inside mid-size firm starts with preparation of the project brief and the establishment of stakeholders' involvement which is followed by the appointed BIM manager who starts an overall process review, that includes planning, managing project documents, and preparation of the project brief. After preparing the project brief, the next step is the “bubble diagram”, followed by the start of schematic sketching that is requested by the project manager, who typically assigns someone to get the proposal/proposals schematically into Sketch-Up. At this point the model typically only represents the project proportion and massing. Once the Sketch-up model reaches the final stage of the conceptual design, the architect usually has a meeting with the client to agree upon the layout. At the same time the project manager assigns another person with the task of laying it out schematically on Revit (Pre-Schematic Drawings). Once the model is transferred to Revit, the process goes back and forth between the appointed BIM manager and the architectural team to develop the concept and basic framework for the design of the project. The model will also be developed to provide “preliminary LEED documents”. The next step is to prepare the preliminary feasibility study, which should be reviewed and approved later by the BIM manager. If the preliminary feasibility study is accepted, the execution plan and design management report (including design process, budget and schedule, communication protocols as well as roles and responsibilities of the various parties) will be presented to the client for the “Schematic Design Approval”. Then, if the client approves these documents, they can proceed to the next phase of the project.

4.0 Mapping BIM “as-is” workflow – design development phase

The Design Development phase involves more inputs from different disciplines. Typically, these inputs are not found in the Schematic Design phase and may include the development of architectural drawings, structural drawings, building services drawings (MEP+HVAC), fabrication drawings and cost estimation. Thus, this phase is more interlinked than the Schematic Design phase and its process model tries to represent dependencies and overall information flow from different disciplines. The existing model for this phase can be summarized in the following steps: After the approval of the schematic design, the architectural team develops the BIM model to illustrate more in-depth aspects of the proposed design; they also verify that the proposed design complies with US building codes and LEED project compliance. After this revision, the project stakeholders usually have a “kick off meeting”, in which they identify the project keys, such as; each stakeholder’s responsibility, scopes, standards, who’s modeling what, levels of detail, push for extra time and fee if it’s more than you’ve budgeted, etc. Typical to the case study, and in the “best case scenario”, the appointed BIM manager sends the BIM model to the MEP team so they simultaneously start MEP and HVAC design earlier at the beginning of the design development phase. Thus, the MEP team starts the development and expansion of the mechanical Schematic Design documents and criteria for lighting, electrical and communications systems that have been suggested by the architectural team. Upon the approval of the MEP and HVAC feasibility study, the BIM manager sends the model to the structural team. After making the required changes, the last step on the structural design is to prepare the feasibility study. Once the feasibility study is accepted, the BIM manager will review the whole business process and project documents. At this time, the architectural team works on landscape design and documentation services as well as the development of outline specifications or materials lists to establish the final scope and preliminary details for on-site and off-site civil engineering work and landscaping work. The next step is the review of the process by the BIM manager. Upon approval, he/she sends the BIM model or the generated project documents to the project manager and the architectural team to review the feasibility case study, prepare the design coordination strategy and cost documents. If the cost estimation needs updating, which may require design changes, the process once more starts again from the beginning by updating the architectural design, which subsequently may require further changes in MEP or Structural Design. The final step in the design development phase is the project review, which includes reviewing project delivery procedures, construction sequencing, and also review and update previously established schedules for the project. Then client approval is obtained before proceeding to the Construction Documents Phase. Figure 3 summarizes the design development workflow.

5.0. MODELING AS-IS WORKFLOW

The BIM workflow has been generated using the BPMN and IDEF methods. Both methods describe the sequence of activities and the flow of information in more details. It should be noted that any As-is model is composed of different levels of details, which could reveal some confidential information about the case study firms. Thus, the As-is model here does not show the BIM activities in detail, however the constraints associated with the workflow are summarized. The model was distributed to a sample of BIM stakeholders upon their requests for more information about BIM procedures and also to compare BIM functions from one firm to another. At this point, the researcher had to go into each business component to explain in detail, such as activities, decisions, communication types, 'performed by whom', and the flow of information. This helped the researcher to get more specific comments and feedback concerning how BIM stakeholders see the existing model and also to identify the problems, which limit a more complete BIM implementation. The proposed model can be used in cases of process improvement in the future. It is important to mention that the details of the As-is model are not listed in this thesis to protect the privacy of the case study firms. It is important to mention that the researcher requested the interviewees' feedback of the envisioned BIM related "To be" workflow from two groups; the first contained some BIM users who contributed to the study from the start. In addition, the BIM workflow was presented to a second group of interviewees, which included not part of the model development. The new model was sent out in both IDEAF (to summarize the process) and BPMN formats to provide interviewees with the capability of understanding BIM business procedures in a more detailed graphical notation, in addition to facilitate the understanding of the performance collaborations and business transactions between the different process components.

6.0 RESEARCH FINDINGS

Having used both the IDEF and BPMN modeling techniques for the "As-is" BIM related process workflow, it was discovered that interviewees are not very interested in an IDEF model to represent workflow but were more interactive with the BPMN model, citing that BPMN was easier to understand. In addition, it provides greater detail about the BIM related workflow, inputs, outputs, actions, tasks and who is doing what, which is vital for the overall comprehension of the workflow. Thus, the presentation of BIM workflow in this paper will be limited to BPMN technique. Usually, IDEF0 diagrams have to be presented to interviewees followed by an explanation of the modeling syntax from the researcher. Without this explanation, it is expected to initially get un-precise, confused or wrong feedback from model readers', which subsequently might cause many users to reject the model at the beginning.

6.1. Advantages of IDEF modeling approach

The major advantage of using IDEF0 is that it consists of a decomposed system, which is found to be easily understood and instantly read. It was found that IDEF0 model saves time that would be spent on the explanation and training of reviewers. Also, this allows the inclusion of a large number of comments from BIM players at one time. The direct contact between the researcher and BIM players allows an efficient development and fluent integration of comments and suggested changes from a large number of reviewers. The arrangement of boxes (activities) does not require a strict sequence, which gives the possibility to manage feedbacks between activities. Also, several activities can occur in parallel to each other, or in sequence depending on a specific activity accomplishment.

6.2. Disadvantages of IDEF modeling approach

Because of the simplicity and readability of the IDEF0 model for non-professionals, this typically doesn't present details for more complicated processes. For example, one of the rules in IDEF0 is that each diagram should consist of between 3 to 6 boxes, which makes it difficult to describe more than 6 activities for each diagram without becoming trivial.

6.3. Advantages of the BPMN

Having more details than the IDEF model, which helps to instantly identify problems in the sequencing or assignment of activities to performers. BPMN uses a swim-lane notation, showing the activities within swim-lanes that indicate each performer's activity, which gives a clear vision about the workflow and "what's going on? And who does what?" to model analysts. When compared to IDEF, BPMN is a more structured, composed, coherent and consistent way of executing and continuously changing end-to-end business processes. BPM usually shows the composed sequence of activities in one diagram and involves all the workflow resources and components in light of their contribution to business performance in the same model. BPMN activities require a strict structure and composed sequence; BPMN combines the Activity Model with the Scenario Sequence Model at the same time.

6.4. Disadvantages of the BPMN

Because the BPMN is quite complicated, and usually combines activities, tasks, processes, sub-processes and other workflow details in one model, model readers' usually get confused and get lost in the diagrams. Because the model usually contains unlabeled arrows and symbols that connect and present BPMN activities, the relationships between these activities may be less apparent and difficult to read by nonprofessionals.

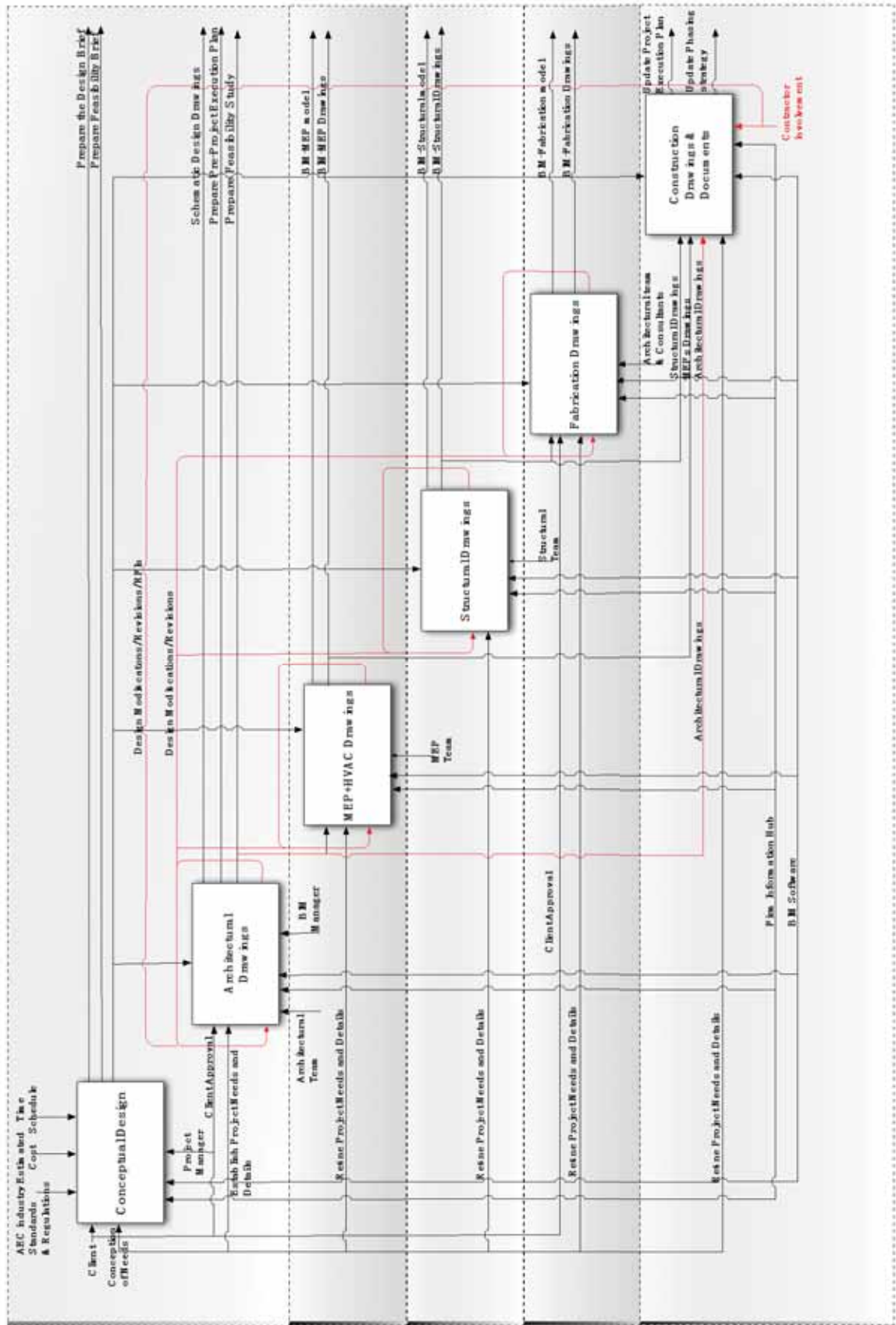

Figure 3: The existing BIM process model using IDEF0.

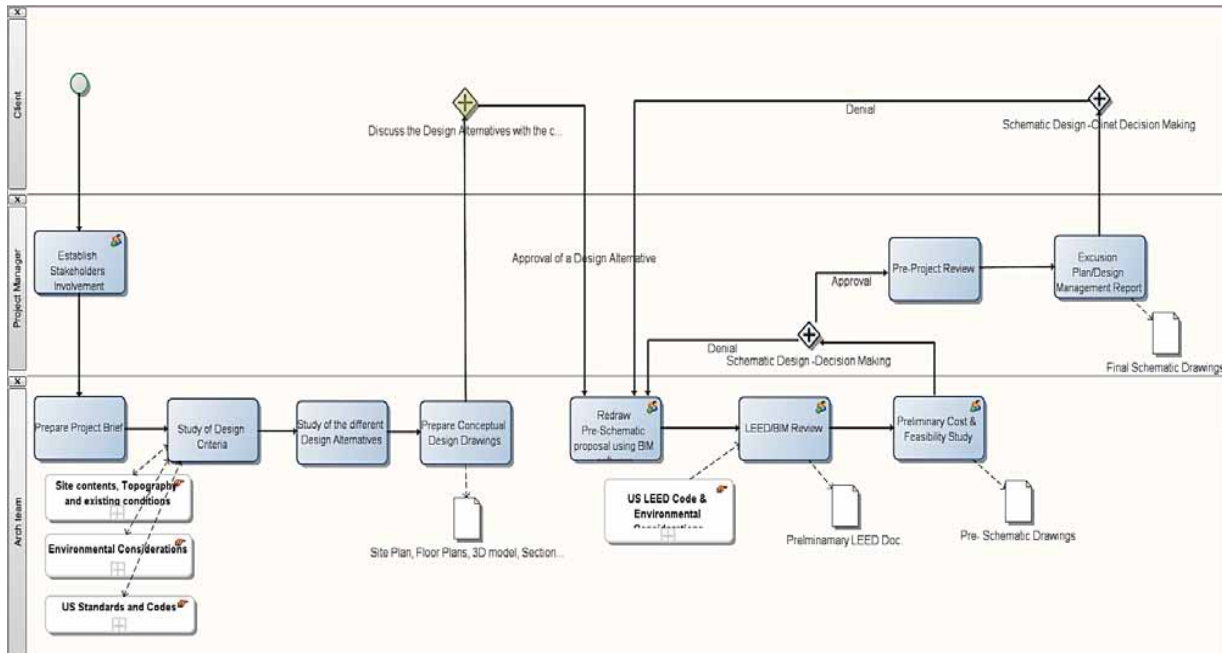

Figure 4: The existing BIM process model using BPMN– Schematic Design Phase.

CONCLUSION

There is a need for new business process models that supports Business Process Re-engineering (BPR) for BIM. The need has emerged for a new business process model, which is able to illustrate how, with the use of BIM, different members of a mid-sized architectural firm could derive benefits and overcome traditional process inefficiencies. In order to effectively adopt BIM in such firms, a redefinition of their current business model is required, one that could lead to a significant change in the work practices.

Thus, this paper focuses on mapping the existing BIM process model and identifying how it functions using two different techniques. The paper explores two of the most popular modeling theories, IDEF and BPMN, and compares between their advantages and disadvantages to help chose one mapping approach for this research. Moreover, it gives reasons for the rise of process modeling in the AEC industry and discusses the criteria for using two modeling approaches, and then presents a comparison between the advantages and disadvantages of each approach.

REFERENCES

- A.I.A (2008) E202™–2008 Building Information Modeling Protocol Exhibit.
- Eastman, C. M. 2008. *BIM handbook : a guide to building information modeling for owners, managers, designers, engineers, and contractors*. Hoboken, N.J., Wiley
- Howell, I. B., Bob 2006. *Building Information Modeling Two Years Later –Huge Potential, Some Success and Several Limitations*.International Journal Of Architectural Computing 04(04).
- Hsiu-Fang Hsieh, S. E. S. 2005. *Three approaches to qualitative content analysis*. Qualitative Health Research. Qualitative Health Research. 9
- McGraw-Hill. 2008. *Smart Market Report, Building Information Modeling (BIM)* Building Information Modeling Trends SmartMarket Report.
- Smith, D. K. and M. Tardif. 2009. *Building information modeling : a strategic implementation guide for architects, engineers, constructors, and real estate asset managers*. Hoboken, N.J., Wiley.

Designing adaptability in practice: Causes and consequences

George Bradley Guy¹, Margherita Pongiglione²

¹The Catholic University of America, Washington, DC

²The University of Genoa, Italy

ABSTRACT: The objectives of this research were to study buildings' design characteristics associated with buildings' intrinsic and major qualities that might provide sustainable design benefits as measured by achievement in the LEED rating systems for new construction and major renovation for whole buildings (NC) or core and shell (CS) projects – and to make comparisons between new construction projects and building reuse projects via their credit point achievement levels.

Given the predominance of existing buildings and the estimated demands for new buildings, it is vital to make use of existing building stock, and design for adaptation and change whilst maintaining a low carbon footprint. This necessity is supported by reports from the IGPC 5th Assessment Report and US 3rd National Climate Assessment Report on climate change effects, and by the US EPA on construction and demolition (C&D) waste and materials production greenhouse gas (GHG) emissions factors. In order to make this need for adaptation and reuse feasible, designers must understand the factors that support adapted building designs, or the extent of influence that the building project parameters can have on these decisions – as well as the environmental values that building reuse may support

The methodology in this study is to use the USGBC LEED certified projects credit achievement data and to characterize key attributes of these buildings via credit achievement between new construction and major renovations. Results are that there is a size range, specific space use types that correlate to building reuse apart from overall amount of construction within certain sizes and types. In addition it was found that LEED Core and Shell and New Construction and Major Renovation (NC) versions 2.X and 2009 new projects achieved equal to better energy reduction than major renovation projects in the same versions, while consistently performing less well in the major sustainable site performance categories.

KEYWORDS: LEED, Adaptability, Building Demolition, Building Reuse, Green Building

INTRODUCTION

The objectives of this research were to assess buildings' sustainable design characteristics that may be supported by adaptive reuse. According to a study by the Athena Institute, most buildings are not demolished because of a structural failure or deterioration however due to significant conflicts between land-use, building type and fit, technology or performance requirements or needs (O'Connor, 2004). In those cases, replacement with a new structure is deemed the appropriate solution at large material and waste environmental impact. In other cases, without a strong location demand, buildings are simply demolished because their very presence is a burden on the owner and community facing an uncertain potential for reuse.

Given the predominance of existing buildings and the estimated demands for new buildings, it is vital to make use of existing building stock, and design for adaptation and change whilst maintaining a low carbon footprint. This necessity is well-supported by reports from the IGPC 5th Assessment Report and US 3rd National Climate Assessment Report on climate change effects, and by the US EPA on construction and demolition (C&D) waste and materials production greenhouse gas (GHG) emissions factors. In order to make this need for adaptation and reuse feasible, designers must understand the factors that relate adaptable building designs, or the extent of influence that the building parameters can have on these decisions. It may also be that over the long-term these goals are in conflict, if existing buildings are impractical to be adapted for new uses and also for energy-efficiency compared to new construction.

The built environment is a major contributor to GHGs which are the cause of increased radiative forcing resulting in climate change. It is estimated that globally, buildings contribute 33% of energy-related GHG and 15% of GHG, and in turn temperatures changes will significantly increase air-conditioning demands in some locations to maintain basic thermal comfort, causing even greater demands for electricity generation (Robert and Kummert, 2012). The built environment is a major contributor to greenhouse gas emissions also from materials manufacture and waste. Cement production alone is estimated to contribute 7-10% to global annual carbon dioxide (CO₂) emissions (IGPC, 2013). The US EPA, in its study "Opportunities to Reduce Greenhouse Gas Emissions through Materials and Land Management Practices", has proposed that increases to 25%, 50%, and 100% recycling rate of C&D debris would result in GHG emission reduction benefits of 40, 75, and 150 MMTCO₂E per year, respectively (US EPA 2009). There are approximately 5

million office buildings in the US with approximately 170,000 commercial buildings constructed and 45,000 demolished, annually (US EPA, 2009). According to the Energy Information Administration (EIA), commercial floor space is expected to grow 35% over the 2006-2030 period, or a rate of growth more than 50% greater than the population at-large. This means that in 2030, 56% of the commercial floor space will have been built after 2000 (EIA, 2014).

Retrofit of existing buildings is one of the most fundamental means to reduce carbon emissions because it extends the life of materials which have already embodied GHG emissions to serve functional purposes. As buildings are designed to be more energy efficient, additional inputs of materials such as insulation, advanced glazing systems, photovoltaic systems, mechanical equipment (primarily metals) which in themselves may be high energy intensity products will be required. This suggests a positive feedback loop of more intensive materials use, without necessarily increasing materials reuse rates, in an attempt to reduce building operational energy-use. The National Trust for Historic Preservation and others have conducted multiple case studies on the buildings using life cycle assessment on the relative whole building life cycle environmental impacts of building new structures versus retrofitting existing structures (Preservation Green Lab, 2012). These studies compare the relative embodied materials impacts for new buildings to 'preserved' embodied impacts through avoided new materials and waste impacts from reuse of some amount of the existing buildings, and then estimates of operational energy for new structures designed to 'high-performance' levels compared to relatively limited operational energy improvements to existing structures. Findings include the contribution of building-use type, envelope materials and design, climate-type, and time-span of analysis. Overall, the use of existing structures is seen as having potential for reduction of environmental impacts in the provision of the built environment.

This research is intended to take an approach that is generalizable, and inclusive of multiple potential benefits of the reuse of existing structures using the USGBC LEED certified project database. As opposed to attempting to assess the comparative value of a new structure versus a major renovation on a case by case basis, the goals of this research is to understand the parameters of existing structures reuse across a wide range of projects. In this case completed projects within the LEED rating system are evidence for future project basis of design which may provide guidance for preliminary valuation of building reuse, and support for this activity from the realms of urban planning, materials and wastes, and building energy-efficiency.

The USGBC LEED rating system, by the nature of different scales and use-types and overlaps of environmental attributes with economic and cultural values in the built environment is one means to attempt to gauge the values of building reuse as a sustainable design measure. This study is bounded by the credit achievements in sets of LEED rating types certified projects that achieved Building Reuse in the Materials and Resources credit category to determine if and how these projects performed differently or 'better' than non-building reuse projects. There are some number of questions, assumptions and caveats to this examination. The utility of this examination is that the USGBC has managed a rating system for over 10 years that consists of over 23,000 certified projects with the attendant data of the project credit submittals (USGBC, 2014).

1.0 GOALS

The original goals for this research, as can be the case in much research, were modified after beginning. Defining a goal and scope was influenced by data availability, type and quality. The trade-offs between for example the use of an in-depth examination of fewer case studies was made in this study to take advantage of a large and digitized dataset that was available through the USGBC LEED projects list. At the same time, the relative coarse-grain and limits of the design for project submittal template and requested documentation also limit the ability to use the data in some respects. The value in this research is the potential offered by the large scale and time-frame of LEED project data, and the fact that it incorporates a well-considered set of environmental building parameters as credits for achievement of the certification.

2.0 METHOD

The method for this research was purposefully intended to examine the utility of the LEED certified projects database and key credits as a means of answering a hypothesis about projects of a certain environmental parameter, in this case building reuse. This became an examination of the LEED credit types, and documentation along with the significance of the selected building attribute characteristics as represented by LEED credits. Clearly the first question might be if LEED buildings are representative of non-LEED buildings in individual credit topic areas. As an example, the oft-criticized bicycle parking credit is a 'purchasable' credit which may not be linked to a measurable or realistic benefit when not related to a dedicated bike lane system linked to the project site. At another extreme, while a project may also 'purchase' renewable energy in some form for a LEED credit, attempting to obtain as high a level of energy-efficiency is building-specific and has an inherent benefit apart from a LEED point achievement.

Similarly, reuse of existing buildings is a relatively low percentage of points in the LEED rating system and its achievement is by no means universal among LEED certified projects. The potential limits of an existing building based on pre-existing site and context determinants might easily make the incentive of achievement of LEED insufficient enough to influence the project's goals to use an existing building. If this is true then for the specific parameters measured by achievement of a LEED point for building reuse may be representative of non-LEED building projects.

With the caveats of possible LEED-centricity or un-centricity established, the hypotheses of the research among LEED projects is that projects utilizing existing reuse of existing building structure, envelopes, interiors respectively will exhibit key potential benefits relative to new projects. In this preliminary research the parameters of interest established from the literature that might be considered highly climate-change related benefits (Wilkinson, 2014) include: size; space use description; optimizing energy performance, and proxies such as daylight and access to views. New construction projects were compared by either point score totals or yes or no credit achievement in a series of credits and across rating system versions for which LEED submittal data was archived electronically by the US Green Building Council.

3.0 RESULTS

The parameters of interest that are measurable by LEED certified project data include building size; location, building type, owner type and credit achievement. In this study projects that achieved building reuse credits were compared to new construction. The initial focus was on size, space type, location, key indoor environmental quality attributes, and energy-efficiency characteristics.

3.1. LEED versions and new construction versus building reuse

This study used two main systems in the LEED catalogue, the core and shell (CS) and new construction and major renovation (NC) systems. The certified projects for CS were from the period of 2003 to 2014. Two versions of CS were used, CS 2.0 and CS 2009, for a total of 1509 projects. The CS project break-down between new construction and major renovation was, 209 projects achieving MRc1 Building Reuse and 1300 new construction projects. The Building Reuse achievement rate was 13.9% of all the projects in the sample.

The NC certified projects used in this study were from the period of 2003 to 2010. Four version of NC were used: NC 2.2; NC 2009; Schools 2009; and Retail NC 2009 for a total of 8692 projects. There were 1068 NC projects that accomplished MRc1 Building Reuse, and 7618 projects that were new construction projects. The Building Reuse achievement rate was 12.4% of projects in this sample.

3.2. Building size

According to the Commercial Buildings Energy Consumption Survey (CBECS) 2012 conducted by the US DOE, 73% of existing commercial buildings in the USA are 10,000 SF or less; 22% are between 10,001 and 50,000 SF and the remaining 5% are larger than 50,001 SF (Fig. 1). The predominance of smaller buildings provides more smaller buildings for reuse, however a distinction was found in the size ranges of LEED projects that achieved any points for the MRc1 building reuse - maintain existing walls, floors and roof and/or interior non-structural reuse in LEED new construction and major renovation (NC), core and shell (CS) and commercial interiors (CI), versions from 2.0 to 2.2 to 2009.

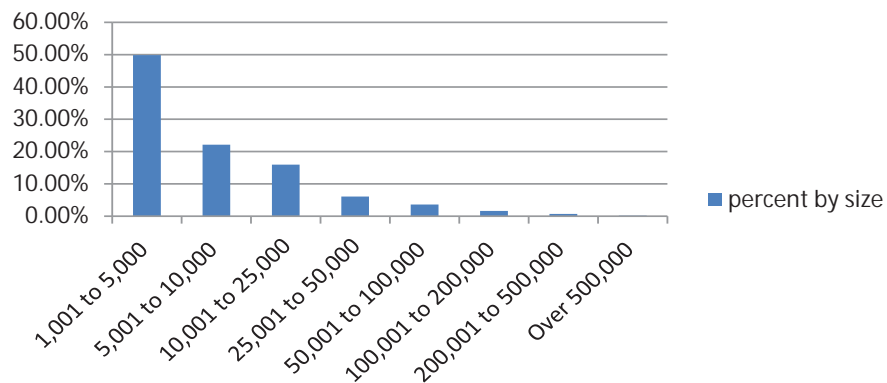

Figure 1: Size ranges of existing commercial building stock in the US, adapted from US Energy Information Administration, Commercial Buildings Energy Consumption Survey (CBECS) 2012 preliminary data, 2014, <http://www.eia.gov/consumption/commercial/>

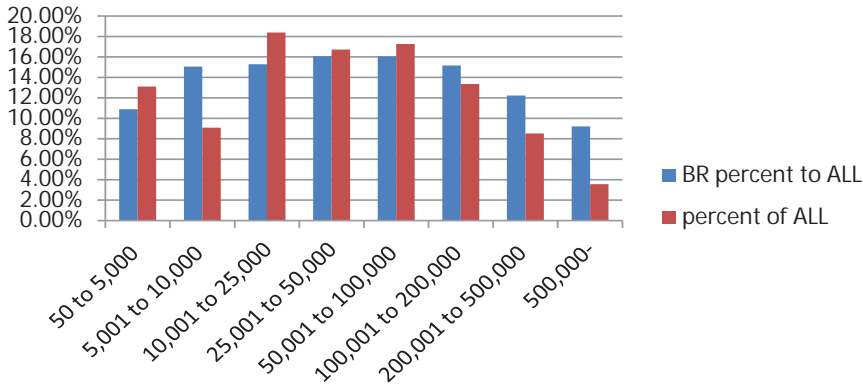

Figure 2: The size distribution of all LEED certified projects as compared to the distribution of projects achieving a point for building reuse.

As shown in Figure 2, LEED certified projects exhibit a different size range than US building stock as a whole and the projects achieving some degree of building reuse somewhat follow this size range categorization.

Building reuse was found to be a greater proportion of projects in the ranges of 5,001 to 10,000 SF and then at the other end of the spectrum of over 100,000 SF. The proportion of projects achieving building reuse points is lower in the range of the smallest buildings of 50-5,000 SF and the mid-range of project sizes from 10,001 to 100,000 SF. One suggestion from the CBECS data is that the scarcity of larger buildings might make them more valuable for reuse over the 50,000 SF size with the greatest difference at the largest size range of 500,000 SF and over. The discrepancy at the 5,001 to 10,000 SF range may be attributable to the larger proportion of buildings in total smaller size however the origins of LEED as a commercial office rating system. This size range of buildings requires further investigation for its strong association to building reuse.

3.3. Space type

LEED projects use a different space type description than the CBECS database, and US government data makes a distinction between commercial buildings, and then industrial buildings, and also between the specific owner-type of the public sector (government) and the private sector. In Table 3 it can be seen that the space types achieving LEED point for building reuse do not align to the proportions of LEED certified projects overall in the main types.

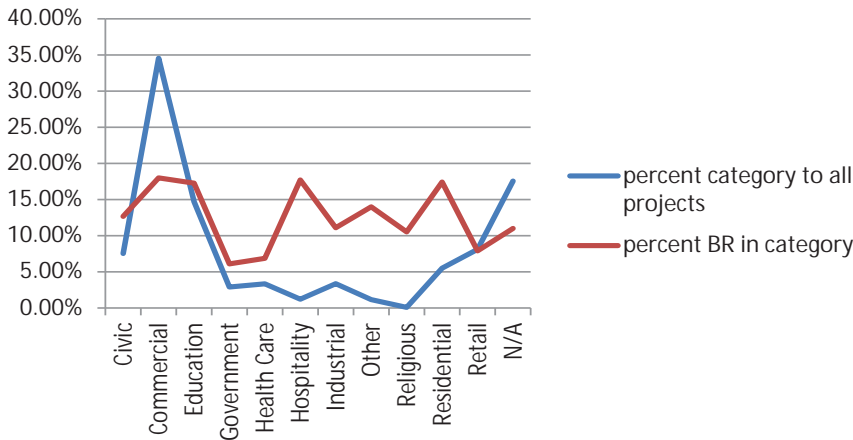

Figure 3: The distribution of LEED projects by space description as compared to the distribution of projects by space type achieving a point for building reuse.

As shown in Figure 3, the major space-use type in LEED certified projects is commercial, including various office types, with education and retail as the secondarily most typical space use type certified to LEED. The points where building reuse is greatest and also a higher proportion in that space type category are primarily

in education, hospitality and residential (multi-family and mixed-use commercial). Hospitality includes various forms of lodging (hotels, motels, resorts) and also lodging such as university dormitories.

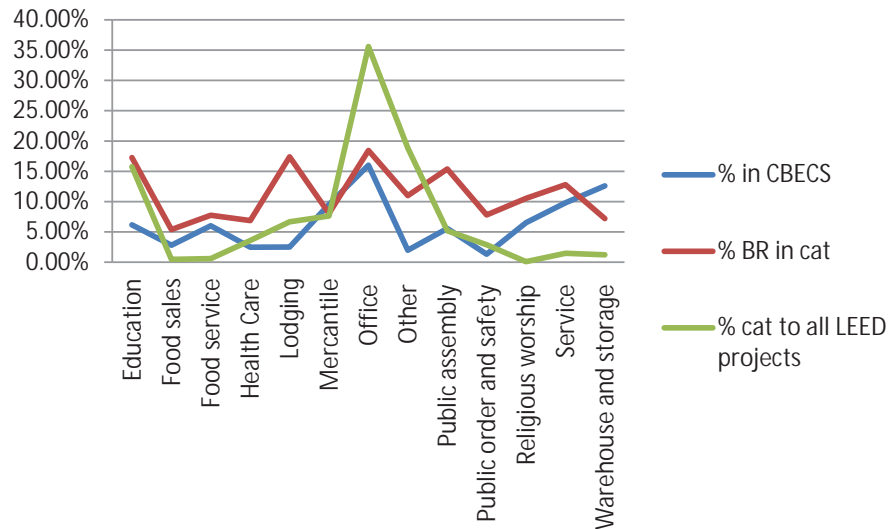

Figure 4: Comparison of number of buildings in CBECs's space type categories to the equivalent space types in LEED projects, and the proportion of projects achieving building reuse.

Figure 4 is a translation of LEED project space description to the building types categories used in CBECs for purposes of comparison. CBECs excludes governmental buildings, multi-family residential and industrial building types. Similarly to Table 3, office use is the dominant space type certified by LEED, followed by education and then mercantile (retail). This chart shows the bias in LEED certification to educational space types within the entire stock of US buildings, and building reuse for lodging. The building reuse projects in LEED more closely align to the proportions of space types in the US building stock as a whole than the proportions of space types certified as LEED projects. Lodging exhibits the characteristic of building reuse more than any other space type either when compared to the US building stock space types and LEED certified projects types. This suggests that without specific effort to design adaptable buildings, that residential uses are most easily created from non-lodging existing buildings. In another context, the mercantile space type exhibits no more building reuse as a proportion of LEED certified projects than the proportion of mercantile buildings in the US building stock as a whole. It would therefore seem desirable to make mercantile buildings more adaptable among different mercantile uses or to other uses.

3.4. LEED credits examined

The LEED credits used in this study to assess the potential inherent sustainable design potential for either an existing building major renovation or a new construction project are listed below. These credits were chosen as either fundamental to climate change such as EAc1 as a single metric of energy-performance or in the case of Sustainable Site credits and certain Indoor Environmental Quality credits, meant to address 'structural' qualities of the project that are intrinsic to its site or for fundamental human health and well-being via the qualities of views and daylight that are most driven by the building envelope, in lieu of credits that are 'purchasable'. The credits and their descriptions are:

- EA1: Optimize Energy Performance – energy reduction above ASHRAE 90.1 requirements.
- SS1: Site Selection – avoidance of inappropriate sites and reduce environmental impacts of site
- SS2: Development Density and Community Connectivity – utilize existing infrastructure and protect greenfields
- SS3: Brownfield Redevelopment – rehabilitate damaged sites, i.e. Brownfields
- SS4.1: Alternative Transportation: Public Transportation Access – location in proximity to mass transit
- EQ7: Thermal Comfort: Daylight or Design
- EQ8.1: Daylight and Views: Daylight 75% of Spaces or Daylight
- EQ8.2 Daylight and Views: Views for 90% of Spaces
- MRc1.1 to 1.3 Building Reuse (25%; 50%; 55%; 75%; 95% of existing walls, floors and roofs, etc.)

3.5. Credit achievement for new and building reuse CS projects

In CS 2.0 rated projects, those achieving the Building Reuse (BR) credit achieved higher percentages of energy-reduction than new construction projects based on average point scores as shown in Table 1. This

difference was tested for significance using T-test analysis and it was found to be valid at the 95% confidence interval.

Table 1: CS 2.0 New and Building Reuse EAc1 Optimize Energy Performance Comparison

Credit	CS new 2.0	CS BR 2.0	95% C.I.
EAc1 point score converted to percent reduction from ASHRAE 90.1	18.5%	24.20%	Yes

As noted in Table 2, in CS version 2009 however, although Building Reuse projects show a slightly greater percent energy-reduction than new construction projects, this result is not statistically significant at a 95% confidence interval. At minimum new construction projects may not on average perform worse than projects achieving Building Reuse credit MRc1.

Table 2: CS 2009 new and building reuse EAc1 optimize energy performance comparison

Credit	CS new 2009	CS BR 2009	95% C.I.
EAc1 point score converted to percent reduction from ASHRAE 90.1	24.20%	26.00%	No

All projects improved their energy-reduction percentages on average from CS 2.0 to 2009, which may be influenced by many factors such as the adoption of LEED and influence it had generally on encouraging higher-performance for all projects. The point structure also changed to increase points for EAc1 and the performance thresholds and maximums were also raised.

The major distinguishing factor for Building Reuse as a sustainable design measure is in the achievement of key sustainable site credits of SSc1 to SSc4.1 that are directly reflective of site location benefits, separately from manipulated factors such as bicycle racks or reducing parking lot sizes. In all 4 credits that were examined, the CS Building Reuse projects' levels of achievement are higher than new construction projects at statistically significant levels as shown in Table 3.

Table 3: CS building reuse projects' levels of achievement and new construction projects comparison

Credit	CS new 2.0&2009	CS BR 2.0&2009	95% C.I.
SSc1	85.77	93.78	Yes
SSc2	64.46	87.02	Yes
SSc3	23.62	38.28	Yes
SSc4	70.69	90.43	Yes

A major distinction is drawn for the Indoor Environmental Quality performance of new versus building reuse projects. In each of the major credits related to daylight and views, which are factors that are heavily influenced by the formal and envelope design of the building as opposed to equipment, controls, and purchased products such as electric light fixtures, the new construction projects on average performed better than the BR projects in the metrics intended to be represented by EQc 8.1-8.2. The credit EQc7 shows a slightly higher rate of achievement by new construction projects, however not at a significant difference with a 95% confidence interval. In this case there is confidence that new construction projects do not perform worse than Building Reuse in achieving EQc.7 and in the metrics of EQc8.1-8.2, perform better as shown in Table 4.

Table 4: Indoor environmental quality performance of new versus building reuse projects

Credit	CS new 2.0&2009	CS BR 2.0&2009	95% C.I.
EQc7	69.77	68.90	No
EQc8.1	33.38	19.14	Yes
EQc8.2	57.00	44.20	Yes

3.6. Credit achievement for new and building reuse NC projects

Similar to the CS projects that were studied, the NC projects achieved higher average energy-reduction percentages over ASHRAE 90.1 from the NC 2.2 version to the NC 2009 versions, gaining an average of 3-4% reduction over the earlier version for both new construction and BR projects. The average point score for EAc1 for NC 2.2 it was 5.42 for new projects and 5.98 for Building Reuse projects and for NC 2009 it was 9.66 for new construction projects and 9.69 for BR projects, respectively. Converting to the percent reduction over ASHRAE 90.1, this equates to an average 24.78% reduction for NC 2.2 new projects and 20.93% reduction for NC 2.2 BR projects and a 28.51% reduction for NC 2009 new construction projects and 25.27% reduction for NC 2009 BR projects. Overall it appears that BR projects had lower energy-reduction achievement than new construction projects, although the point scoring has created the result that

the Building Reuse projects achieved slightly higher average EAc1 point totals in both versions of NC 2.2 and the NC 2009 versions.

Table 5: NC 2.2 New and Building Reuse EAc1 Optimize Energy Performance Comparison

Credit	NC new 2.2	NC BR 2.2	95% C.I.
EAc1 point score converted to percent reduction from ASHRAE 90.1	24.78%	20.93%	Yes

In NC 2.2 new construction projects achieved higher percentages of energy-reduction than BR projects as noted in Table 5. As noted in Table 6, this relationship remained the same in NC 2009.

Table 6: NC 2009 New and Building Reuse EAc1 Optimize Energy Performance Comparison

Credit	NC new 2009	NC BR 2009	95% C.I.
EAc1 point score converted to percent reduction from ASHRAE 90.1	28.51%	25.27%	Yes

All projects improved their energy-reduction percentages on average from NC 2.2 to 2009, which may be influenced by many factors such as the adoption of LEED and influence it had generally on encouraging higher-performance for all projects. The point structure also changed to increase points for EAc1 and the performance thresholds and maximums were also raised.

Table 7: New construction projects and NC building reuse projects performance comparison

Credit	NC new 2.0&2009	NC BR 2.0&2009	95% C.I.
SSc1	86.24	95.04	Yes
SSc2	60.49	76.12	Yes
SSc3	19.86	27.81	Yes
SSc4.1	59.92	60.86	No

Similarly to the CS projects, the NC Building Reuse projects performed better or in the case of SS4.1 equal or not worse than new construction projects on average in achieving this suite of credits (Table 7).

In the comparison of SSc4.1 for new and BR projects 59.92% of both NC 2.2 and NC 2009 projects that were new projects achieved SSc4.1. 60.86% of both NC 2.2 and NC 2009 projects that achieved the BR credit also achieved SSc4.1. Based on the sample size of 7618 for new projects and 1068 for BR projects, the average higher achievement rate of SSc4.1 for BR projects compared to new NC construction projects is not statistically significant at a 95% confidence level. It is not possible to conclude that Building Reuse NC projects achieve SSc4.1 at higher rates compared to new NC construction projects.

The major distinguishing factor for Building Reuse as a sustainable design measure is in the achievement of key sustainable site credits of SSc1 to SSc4.1 that are directly reflective of site location benefits, separately from manipulated factors such as bicycle racks or reducing parking lot sizes. In all 4 credits that were examined, the Building Reuse projects' levels of achievement are higher than new construction projects at statistically significant levels or in the case of SSc4.1 either equal or not worse in achieving access to public transportation which is a major factor in reducing buildings' contributions to greenhouse gas emissions.

In the comparison of EQc8.1 for new and Building Reuse projects, 38.75% percent of both NC 2.2 and NC 2009 projects that were new projects, achieved EQc8.1 daylight and views. 19.57% percent of both NC 2.2 and NC 2009 projects that achieved the Building Reuse credit also achieved EQc8.1 daylight and views. Based on the sample size of 7618 for new projects and 1068 for Building Reuse projects, the average higher achievement rate of EQc8.1 for new NC 2.2 Building Reuse projects compared to Building Reuse construction projects is statistically significant at a 95% confidence level. It is possible to conclude that new construction projects achieve EQc8.1 at higher rates compared to Building Reuse NC projects.

Table 8: NC new construction projects and NC building reuse projects performance comparison

Credit	NC new 2.0&2009	NC BR 2.0&2009	95% C.I.
EQ8.1	38.75	19.57	Yes

A major distinction is drawn for the indoor environmental quality performance of new versus building reuse where a basic constraint that might be imposed by the reuse of an existing building is its floor plan layout and envelope characteristics that might limit access to daylight and views as a measure of sustainable design for both energy-efficiency potential and fundamental occupant well-being. In the case of new construction, there are no intrinsic barriers to the provision of these features as there might be in the case of an existing building.

CONCLUSION AND FUTURE RESEARCH

Based on analysis of LEED project submittal data for new construction and major renovation (NC) rating types of version 2.2 and 2009, buildings that achieve building reuse exhibit distinctions from new construction projects. In particular NC projects that are adaptive reuse projects do not appear to achieve higher energy performance and indoor environmental quality over new construction projects. Conversely, major renovation projects consistently exhibit preferable site characteristics as exemplified by the Sustainable Site credits 1 to 4.1 in LEED. It may be that building reuse for reduction of greenhouse gas emissions is more profound regards location aspects than inherent design features and that the LEED credit achievement illustrates the limits to improving energy-efficiency even when rewarded by both the financial benefits of energy-use reduction and the indirect benefits of a higher LEED rating. Further research is needed to understand the value of building reuse from a materials perspective if operational energy benefits are at best case neutral compared to new construction. The possible consequences of poorer indoor environmental quality in building reuse projects also requires examination of the how to overcome these possible intrinsic issues and future design to insure that new construction can embed daylight and views in a robust manner.

REFERENCES

- Energy Information Administration (EIA), <http://www.eia.gov/electricity/data/browser/>, visited February 17, 2014.
- Franklin Associates. The Estimated Amount of Building-Related and Road-Surface-Related Construction and Demolition Materials Generated and Managed in the United States During 2003, prepared for the US Environmental Protection Agency, July, 2007.
- IPCC, 2007: Climate Change 2007: The Physical Science Basis, Contribution of Working Group I to the Fourth Assessment Report of the Intergovernmental Panel on Climate Change, Solomon, S.; Qin, D.; Manning, M.; Chen, Z.; Marquis, M.; Averyt, K.B.; Tignor, M.; and Miller, H.L., (ed.), Cambridge University Press, Cambridge, United Kingdom and New York, NY, USA.
- IPCC, 2013: Climate Change 2013: The Physical Science Basis. Contribution of Working Group I to the Fifth Assessment Report of the Intergovernmental Panel on Climate Change, Stocker, T.F., D. Qin, G.-K. Plattner, M. Tignor, S.K. Allen, J. Boschung, A. Nauels, Y. Xia, V. Bex and P.M. Midgley (eds.), Cambridge University Press, Cambridge, United Kingdom and New York, NY, USA.
- O'Connor, J. 2004. Survey on actual service lives for North American buildings, Presented at the Wood frame Housing Durability and Disaster Issues conference, Las Vegas, NV, October
<http://www.woodworks.org/wp-content/uploads/2012/02/fpi-survey-actual-service-lives.pdf> visited December 5, 2014.
- Preservation Green Lab, The Greenest Building: Quantifying the Environmental Value of Building Reuse, 2012 <http://www.preservationnation.org/information-center/sustainable-communities/green-lab/valuing-building-reuse.html> visited December 5, 2014
- Robert, A., Kummert, M. 2012. Designing net-zero energy buildings for the future climate, not for the past, *Building and Environment*, V. 55 150-158.
- Wilkinson, S.J., Remoy, H., Langston, C. 2014. *Sustainable Building Adaptation: Innovations in Decision-making*, Wiley Blackwell.
- US Energy Information Administration, Commercial Buildings Energy Consumption Survey (CBECS) 2012 preliminary data, 2014, <http://www.eia.gov/consumption/commercial/> visited December 5, 2014.
- US EPA, Opportunities to Reduce Greenhouse Gas Emissions through Materials and Land Management Practices, Office of Solid Waste and Emergency Response, September, 2009, visited October 1, 2010. http://www.epa.gov/oswer/docs/ghg_land_and_materials_management.pdf
- USGBC, Personal communication Sean McMahon and Chris Pyke, USGBC, 2014.
- US Green Building Council LEED rating systems on-line, www.usgbc.org, visited October, 2014.

Designed for performance: A collaborative research studio rethinks glass curtain wall systems

Michael D. Gibson¹

¹Kansas State University, Manhattan, KS

ABSTRACT: The growing demand for high performance buildings has pushed the architectural discipline to confront building performance as an integral part of design delivery, while increasing the necessity of collaboration between designers, building science experts, engineers, and manufacturers to find the best solutions to building performance challenges. This paper presents the research of a year-long architectural studio engaging a team of practitioners and outside consultants along with a major manufacturer of window systems. Student research teams were charged to rethink the modern curtain wall from the ground up, questioning its material, environmental integration, and manufacturing implications. Glazed curtain walls as a system have remained virtually unchanged for decades while great strides have been made to improve the environmental performance and durability of glass units. While the postwar industrial complex established extruded aluminum grids as the prevailing core of these systems, the research of the studio hypothesizes that new structural, material, and fabrication approaches can improve the environmental performance and architectural integration of curtain wall systems. Three experimental systems developed during the studio are presented in the paper, along with preliminary performance data showing their relative successes and shortcomings versus a contemporary high-performing curtain wall system. Prototyping, analysis, and simulation methods are also detailed. While the current body of research presented focuses on curtain wall systems, critical links are drawn between the research studio and practice with regard to how performance is evaluated and integrated as part of the design process of high performance buildings.

KEYWORDS: Envelopes, Performance, Simulation, Testing, Prototyping

INTRODUCTION

In the recent book *Design Informed* (Brandt 2010), Susan Ubbelohde and George Loisos talk about architectural problem solving in a performance-based practice as “one of the best ways to encourage innovation and creative response.” The challenge of designing high-performance buildings require architects to engage building science and manufacturing in a more direct way in the past, providing an opportunity to drive innovation by connecting performance objectives to emerging, integrated design strategies. Requisite to this level of engagement is collaboration in the design process among architects, building science experts, engineers, and manufacturers to find the best solutions to building performance challenges. Architects are uniquely positioned to understand the context and potential integrated response to such performance problems because the profession is situated between the technical aspects of the building and the multimodal performance objectives driving the project: objectives transcending the engineering of the building to address the larger ecology of the building’s environment, function, and service to its occupants.

Inevitably, the pursuit of performance problems reveals knowledge gaps in what is known about building behavior and building assemblies. Whether small or large in scope, these gaps in knowledge appear with acuity to architects engaged in the profession. In the past, knowledge and technological resources were not readily available to the professional (or the manufacturer for that matter) to explore every gap in knowledge encountered. Today increased availability of design and analysis software has coupled with new openness to collaborate across disciplines to make inquiry, analysis, and testing a potentially more integral part of everyday practice. In the last decade several firms have lead the rest of the profession in introducing research into practice: namely SOM, Perkins + Will, and Kieran and Timberlake.

This paper presents the research of a year-long architectural studio in the Department of Architecture at Kansas State University that engaged a team of practitioners from BNIM and PGAV (Kansas City architecture firms), outside engineers and specialist consultants, and Manko Window Systems in a research and design project during the 2014-15 academic year. Students working in teams were charged in the research studio to rethink the modern curtain wall from the ground up, questioning its material, environmental integration, and manufacturing implications. A major goal of the studio was to introduce students to a research approach in which building science concepts, experimental methods, simulation and

analysis tools, and prototyping could be deployed, suggesting perhaps a knowledge base valued in a profession that will increasingly be involved in research in the future. In this context the collaborating team of professionals and manufacturer provided real-world insight and feedback during the project.

1.0 CURTAIN WALLS: PERFORMANCE CHALLENGES AND POTENTIAL SOLUTIONS

In the early phase of the studio, knowledge of the history of curtain wall system was assembled from a literature review and from interaction with Kevin Dix, the head engineer and Vice President at Manko, who contributed decades of experience in the commercial fenestration industry. Kevin and Manko's insight was also critical because as a small yet successful regional manufacturer, the company has actively developed its product line using the latest materials and manufacturing methods, while testing its products to residential and commercial AAMA and NFRC standards. Thus the engineering and production process of aluminum curtain wall systems at Manko is more influenced by the performance opportunities and tradeoffs than manufacturers whose limited product lines require less in the way of testing.

While visiting Manko's manufacturing facilities, it became apparent that behind contemporary glazed curtain wall systems are a collection of technologies that in some areas have developed aggressively, yet in others have remained unchanged for many decades. For example, glazing technology has evolved greatly, with manufacturers now employing highly precise, automated production of insulated glass units (IGUs). These vastly improved IGUs are manufactured with metered argon that is contained by new, highly resilient sealant and silicon (versus metallic) spacer combinations, and new coating technologies that reduced thermal transmission (U-Value) of mid-century double-glazed IGUs by a factor of over four, with the best performing systems achieving U-Values approaching 0.125 BTU/hr*ft²*°F: a number very close to an opaque, insulated cavity wall. At a company like Manko the most significant recent production investments have been focused on the production of insulated glass units.

On the other hand, the aluminum frame systems used for stick and unitized curtain wall have remained virtually unchanged for decades, with the main improvements involving the use of better-performing gaskets and thermal breaks, specifically using polyamide and other advanced materials. Yet the basic system and profiles of aluminum systems persists, with manufacturers offering nearly identical products. A few explanations exist for this stagnation in technology that illustrate the timeliness of innovation in this field. The first explanation involves intellectual property: PPG, a major player in the glass, coatings, and curtain wall industry, abandoned curtain wall production and sales in the 1980s. Subsequently their designs and extruding dies became free-to-use 'house dies' for other aluminum extruders in North America, offering established engineering and manufacturing infrastructure and becoming the template for the ubiquitous aluminum curtain wall profile of today. The second explanation behind the establishment of aluminum curtain wall is an historical one. The historian David Yeomans attributes the development of the aluminum curtain wall to the postwar industrial complex, which sought to repurpose the aluminum extruding capabilities from the construction of warplanes for domestic production (Yeomans 2001). Yeomans argues, additionally, that curtain wall development was driven not merely by the aesthetic of glass, but by the utility, durability, and economic efficiency of these modular systems whose initial deployment was in factories, retail buildings, garages, schools, and laboratories (Yeomans 1998). Simplicity and utility drove the evolution of these systems and these objectives have been met well by the familiar aluminum extrusions.

Paradoxically, attempts at revolutionary improvement to these systems in the 1950s and 1960s never stuck. Yeomans discusses an author and researcher named Robert Davison, an early advocate of aluminum curtain wall systems who through the 1930s to the 1960s fervently promoted the idea of insulated metal panels as a way to improve thermal performance of these systems (Yeomans 1998). Davison's essays on this subject show no shortage of technological vision, discussing aerogels and exotic foamed materials decades ahead of the green material surge of the 21st century; it is also worth noting that Davison's vision for these systems focused on the economy and function of vernacular applications rather than the monumentality of glass (Davison 1947).

One of the major performance challenges of the glazed aluminum curtain walls is thermal performance, with both aluminum frames and glass infill having high thermal conductivity and the sealing and gasketing of the assembly required to ensure airtightness. The issue of embodied energy in aluminum is also complex, because while aluminum commonly contains a high amount of recycled content, the use of anodized coatings in curtain walls requires that aluminum is high quality 'virgin' aluminum. The production of glass is also energy intensive, with large amounts of energy consumed in glass production and the significant creation of waste from glass pre-production, breakage during shipment, and the expiration of inventory due to factors such as the oxidation of low-E coatings. A last reality of curtain walls is that the final curtain wall performs only as good as it has been installed; in particular the interfaces between CW and other walls

are not tested as part of the systems' ratings and can be a major source of performance problems (Boyle 2013).

Yet the opportunities presented by glass and aluminum curtain walls are positive. First, these systems can be very affordable, with straightforward erection and expectations for performance (thermal and otherwise) in comparison to layered walls using materials like veneer stone and brick with insulation in cavities. Secondly, the use of glass presents particular risks for condensation, when the interior glass surface drops below the dew point temperature of the interior environment. Thermally-broken aluminum framing systems help to maintain temperature isotherms through the glass IGU by transferring heat to the edges of the glass, where it is covered up by the aluminum frames. Quite by accident, an early experiment by a student group replaced the aluminum framing with wood mullions; the wood mullion insulated the edge of the glass from the interior, allowing heat loss to occur laterally along the glass, dropping the glass temperatures at the edge of the simulated assembly and suggesting an acute condensation problem. In summary of these points, glass units and aluminum frames work together well to address issues of constructability and condensation.

Another important advantage presented by these systems is one of airtightness, although traditionally fenestration systems were perceived a weakpoint in the building envelope. A recent assessment of the role of infiltration in energy use of commercial buildings (Emmerich 2005) developed a target infiltration rate used for energy models of 1.2 L/s-m² (0.24 cfm/ft²) @ 75 Pa (1.58 psi) based on modern construction data with a 'best achievable' infiltration rate of 0.2 L/s-m² (0.04 cfm/ft²) @75 Pa (1.58 psi); in this paper, only 6% of a set of existing buildings tested met the target standard for infiltration. The same study estimates that reducing infiltration rates in commercial buildings to the target rate would save 40% in gas savings and 25% in electrical savings in heating dominated climates (Emmerich 2005), indicating that one of the most significant challenges in meeting efficiency targets comes from building airtightness. Yet modern wall and fenestration systems promise extremely tight assemblies: where is the problem? Modern efforts with building envelope commissioning has identified that the typical source of infiltration in buildings is not within the wall or fenestration systems in the envelope but at the interfaces between them where air barriers must properly transition (Boyle 2013), which are particularly acute in buildings with punched openings. One may surmise that a solution to the problem of infiltration is to adopt a reliably tight system and transition between glazed and opaque walls within that system. The triple glazed curtain wall system available from Manko infiltrates at 0.06 cfm during a test at 6.24 psf; if the system could maintain such tightness continuously across an entire building envelope it could easily perform below the targets cited in Emmerich (2005). Albeit this comparison is based upon different tests (whole building infiltration versus assembly infiltration) and doesn't address the challenge of establishing continuity at floors, roofs, and other challenging areas; yet it is possible that high performing glazed curtain wall systems could be an important component to improving energy efficiency when infiltration is critical.

2.0. STUDIO RESEARCH PROCESS AND METHODS

Proceeding from background research and interactions with Manko, the research studio's goal was to develop new curtain wall systems that recognized the advantages of tightly-sealed high performance glass but reconsidered how the glass would be integrated in a curtain wall to increase overall efficiency with respect to energy. This paper presents a comparison of Manko's highest performing system with three experimental systems developed and tested by the students. The system from Manko is a thermally-broken 2.5-inch profile curtain wall system using triple glazed, argon-filled IGUs: one of highest performing curtain walls available for commercial projects.

Students worked in teams of three to develop and test their experimental systems, modeling a progression of testing methods inspired by the methods used by Manko. Development began in a "what if" stage where teams developed basic hypotheses about system performance and the physics supporting the efficiency assumptions for their systems. Material and structural capacities were interrogated during this phase, with the groups proceeding to model and simulate their hypothetical systems using THERM and WINDOW simulation tools from Lawrence Berkeley National Labs. THERM and WINDOW test two-dimensional sections through walls, frames, and window glass using finite element analysis to predict temperatures throughout the test section as a result of multiple modes of heat transfer, using prescribed boundary conditions (i.e. environmental conditions) at each side of the wall. Because the NFRC uses this software in its certification process (ANSI/NFRC 100-2014), these simulations allowed the research teams to compare their systems to Manko's official NFRC certification models using the same simulation configuration and boundary conditions. At this stage student groups also tested a number of alternative hypotheses at a time, using failed ideas to inform decisions about how to improve the performance of successful ideas. Using THERM and WINDOW early in the process took advantage of the relatively quick turnaround and low-risk associated with computer simulation, something also done at manufacturers like Manko to vet new product variations and improvements prior to prototyping.



Figure 1: Image showing test structure and 1:1 scale prototypes constructed by the students for thermal testing. Source: (Author 2014)

Following the development of experimental systems in THERM and WINDOW, students worked to extrapolate thermal properties outputted in THERM and WINDOW (such as U-Values, Solar Heat Gain Coefficients, and Visible Transmittance) into Autodesk Ecotect whole building energy simulations using a studio-wide test model. The test model represented a skin-load dominated office building of 24,000SF located in Des Moines Iowa with IECC prescriptive envelope properties and 38% glazed wall area and included internal and ventilation gains according to IECC guidelines. This effort allowed students to determine the monthly, seasonal, and annual impact of their experimental systems as part of a realistic, hypothetical commercial building.

The last phase of development was the production of a series of two prototypes, built at 1:1 scale. The first prototype was a 'desktop model' that served as a proof-of-concept during discussion with the collaborating manufacturer and architects. For this model, students set about addressing issues of fabrication and assembly that are inevitable when moving from virtual models into real physical objects that must negotiate imperatives of construction. Feedback from the small prototype and the simulations ultimately led to the design and fabrication of a larger 1:1 prototype that each team completed to fill a 27 inch wide by 74 inch high rough opening. These large prototypes were completed using material and assembly techniques that were as realistic as possible, with IGUs and curtain wall hardware supplied by Manko. In addition to the five student-developed prototypes, a curtain wall unit was assembled by Manko at the same dimension. Together these six curtain wall sections were installed in the southern wall of a test enclosure measuring 16 feet long, 8 feet deep, and 8 feet high which was erected on a gravel pad outdoors with maximum exposure to the south, southeast, and southwest. The envelope (walls, floors, and ceiling) of the test enclosure was finished with 3.5-inch Raycore Structural Insulated Panels with an additional 0.75 inches of polystyrene insulation over the exterior (see Endnotes 1 for more information on test house construction). Constructing the prototypes and using them to test real world performance is the procedure used by Manko because real world multidirectional heat transfer, assembly-related problems, and infiltration cannot easily be tested using virtual prototypes. Conventionally these tests would also be carried out for water penetration and structural resistance; however, the studio chose to focus on thermal performance.

Data collection carried out in the test enclosure included continuous monitoring of normally aligned interior and exterior surface temperature points at select sites on each prototype, along with temperature of interior and exterior environments and instantaneous thermal imagery collected with a thermal camera. Temperature data, collected by thermocouples and data acquisition devices, was used to calculate continuous and averaged heat flow rates at the interior surface of the test sites. The equations and instrument configuration for thermal tests are described in the endnotes. During tests, a small,

thermostatically controlled space heater was used to maintain a relative interior temperature in the test enclosure, with a set point roughly at 68F. The space heater was directed away from the curtain wall prototypes in the interior and because of the small size of the space heater, forced convection had a negligible effect on the individual prototypes and sensors. Data was collected to establish a baseline infiltration (air leakage rate) for the entire enclosure. In series, each individual prototype was tested for infiltration by masking off the other prototypes; per ASTM standards infiltration testing focused on leakage within the window unit rather than around the outer frame, and perhaps related more closely to the continuous condition of a curtain wall system rather than the extreme edges. Experimental setup and data collection for tests is described in greater detail in the endnotes. Overall the fabrication and full scale testing of the experimental systems served to confirm the viability of the systems against real-world conditions and concerns.

3.0. EXPERIMENTAL SYSTEMS AND FINDINGS

Three experimental systems and the base system from Manko are compared in this paper, with descriptions of each system, their conceptual bases, and a discussion of findings from simulation and testing:

3.1. Base System: 250i system from Manko window systems

The system provided uses aluminum frame using an internal polyamide thermal break to fully isolate the exterior pressure plate and cap from the interior frame. The glazing unit used was a triple glazed, argon-filled IGU using Low-E glass and structural silicone spacers and a factory edge seal, installed with EPDM gaskets on interior and exterior in the curtain wall frame (Fig 1). Joints in the assembly of the frame were friction-fit with factory-supplied hardware and further sealed with silicone. This system represents the thermally highest performing system available from the manufacturer but generically represents a top-of-the-line glass curtain wall that is becoming more widely available.

The performance of the base system is discussed in the comparisons of experimental systems below. It should be noted that the base system was assembled in the factory by an experienced fenestration contractor as part of a demonstration organized for the students, while the experimental systems were devised in part or wholly in the college shop. It should be noted that Manko's system set a very high performance bar particularly for infiltration with nearly immeasurable leakage in testing.

3.2. System A: Structural spacer in insulated glass units

This system was developed by a team that acknowledged the curtain wall frame's cross section (and the aluminum contained in it) typically isn't used to its full structural capacity in the horizontal direction, while it merely transfers loads from the glass to the vertical mullions which justify the full geometry of the frame for structural reasons. Additionally the team recognized that with high performance IGUs, it was often the frame that had the lower thermal resistance; eliminating any part of the frame could increase the overall thermal resistance of the system. The response developed by this group was to integrate a steel member in the horizontal orientation in the IGU which would also serve as the spacer on those edges. The team recognized that this would require slightly denser spacing for vertical mullions, since the span of the steel member would be limited structural. The spacer designed by the team is capable of spanning 6' in a 24 sq. ft. IGU according to structural calculations for resisting dead load and wind loads and given the allowable deflections in the glass and adhesives. Secondly, the team's IGU requires two internal films in the glass cavity to prevent convection. Computer simulations were carried out with the IGU using an argon fill and Low-E films, while the prototype constructed by the team was filled with air and used uncoated Mylar films. The frame designed by the team integrated a steel shelf that was bolted to the frame prior to installation; assembling the system required setting the IGUs on the shelves and using conventional pressure plates and covers to complete the installation. A compressible foam gasket was used in the horizontal joints between IGUs, and the interior and exterior joint was sealed with silicon as a final step.



Figure 2: Manko's 250i system with triple glazing and thermal break (left) and System A prototypes and thermal simulation. Source: (Author 2014)

Virtual testing in THERM indicated an increase in thermal resistance of 59% compared to the base system, a significant improvement (Table 1). It appears that much of this improvement comes from an elimination of surface area at the frame where mullions have been eliminated; though the thermal resistance at the structural space actually decreases, this is locally a much smaller area for heat transfer than the conventional mullion. Improved thermal properties were then simulated with whole building energy modeling (Autodesk Ecotect) in a 24,000SF commercial building. In comparative simulations, combined HVAC energy usage was reduced by 17% by using this system versus a high-performing double glazed system. Secondly, the research team also used Ecotect to simulate the improvements to daylight factor offered by their system versus the base system; in a room with a 2:1 depth to height ratio, daylight factor increased 20%.

In the prototype testing, the system performed quite well despite some compromises in the prototype materials: namely in the improvised IGU, which used uncoated Mylar rather than a low-E coated film, and also used air in glass unit rather than argon. Despite these compromises the glazing unit performed very closely to the manufacturer's base unit, with interior temperatures and heat transfer rates within only slightly increased over Manko's. The temperatures at the center mullion were much lower for the prototype than the manufacturer's unit, as predicted by THERM; however the site of increased heat transfer was highly localized when viewed with thermal imagery. While not measured, light admittance and view through the small prototype was increased notably in comparison to the more bulky conventional center mullion in the manufacturer's unit. This prototypes leaked through the improvised IGU during infiltration testing, producing deflection in the Myler interlayer; this prototype's air leakage results could be improved, and even so, the system was tighter than the test enclosure (Table 3).

3.3. System B: Composite node system

A team of students developed the composite node system in response to two strategies. The first addressed the availability of relatively low cost, multiwall plastic products that are less conductive than glass but retain translucency and daylighting potential. These products are used in place of glazing quite frequently in commercial curtain wall systems; however the light weight and relative affordability of the plastic can allow it to easily be deployed in a double-wall system. Coincidentally some manufacturers of multiwall plastic offer such solutions. In response to this concept, the team developed a framing system that would allow for a deep section (for thermal resistance) that could accept a multiwall polycarbonate skin on both interior and exterior sides. Within the section, translucent polymer fiber insulation fills the gap. The second issue addressed in this system is that of thermal transmission through the aluminum framing. To respond to this problem the team devised a framing system consisting of interior and exterior 'rails' that interface with either polycarbonate or glass IGUs with conventional curtain wall pressure plates and cover caps. Between the framing rails, composite nodes intermittently tie the rails together and allow connections throughout the systems and to the building. The ingenuity of the system is that it allows conventional vision IGUs and operable windows to be introduced freely within the system. Weather stripping, mechanically installed pressure plates, and conventional sealants complete the air and water barrier on the exterior face while the interior wall would be unsealed to prevent venting and equalization of vapor from within the wall cavity.

One of the most important implications of this system is that aluminum is used in an advantageous manner – to create a resilient, easily erected wall system – yet the amount of aluminum in the frame is reduced by

using the rail and node system in place of larger and heavier rectangular profile reducing thermal transmission. Additionally, most of the aluminum in the system (except the caps) is inside the wall; this would allow the system to use a non-appearance grade of anodization for the rails, allowing the use of recycled aluminum instead of virgin aluminum.



Figure 3: System B diagrams and thermal simulation (left) and System C prototype and thermal simulation (right). Source: (Author 2014)

Simulations in THERM show that thermal resistance of the infill system with a 6" deep cavity would increase by a minimum of 65% at node connections to a maximum of 84% in the cavity areas of the system (Table 1). Whole building energy simulations were then used to compare performance of the 24000SF test building using this system versus the manufacturer's base system; calculating an aggregated U-Value for a composite wall of 20% glazing and 80% polycarbonate infill, the building HVAC energy usage is reduced by 20%. The team also conducted several daylight simulations using Radiance to evaluate the impact of their system for daylight diffusion, distribution, and glare prevention.

The team constructed their prototype after developing a series of smaller models to refine the design of the rails and nodes, especially the connecting interfaces. The final 1:1 prototype used improvised aluminum rails composed of curtain wall 'Ts' – a profile without the structural box. The Ts were then welded to extruded aluminum Ts to create a profile approximating the dimensions and stiffness of the rails designed by the team. The composite nodes were constructed from glu-lam beams that were milled and machined in the shop. Because the node design allowed a single node shape to be used for any of the connections in the system, fabrication of the nodes was very easy. As constructed, the system used polycarbonate from a local hardware store for the skin, loose polyester fiber to insulate the cavities, along with an IGU, caps, pressure plates, and weatherstripping provided by Manko. Performance of the system in real conditions was remarkable, with the interior polycarbonate skin remaining near environmental temperature and at a much higher temperature than the base system's glazing throughout the test. The interior frame cap also showed a reduction in thermal transmission, matching the glass temperature of the base system and reading warmer than the base system's frame. In summary the testing of the prototype confirmed expectations from computer simulations and showed that the main strategies of the system to reduce thermal transmission were working as expected. Infiltration tests were telling as well, with infiltration rates much lower than the SIP envelope of the test enclosure and lower than other group's prototypes (Table 3). While not as tight as Manko's system, this prototype had many more parts and opportunities for leakage and yet performed well, demonstrating that the depth of the system and redundancy has a payoff in tightness.

3.4. System C: Structural foam composite

The final system discussed in this paper was developed by a group interested in unitized curtain walls: those differing from stick systems in that the units are assembled in controlled conditions in the factory and set as units in the building façade. Other interests of the group included construction via 'grand blocks' as that used in the fabrication of large ships, and non-linear construction, where assembly or disassembly sequencing can be flexible and future modification and service is simplified. The group began with the assumption that in high performance buildings, a tightly controlled glazing area suggested a different approach was required than that used in aluminum framed curtain walls that use infill panels similar to insulated glass units. The solution developed by the group after some experimentation and research was that a high-performance foam panel could both support vision and operable glass, while also distributing loads from the panel to attachment points. Simple calculations confirmed that structural foam products have enough structural

capacity to support large IGUs (50SF and larger) so long as minimum foam areas are maintained around the perimeter of the glass. Such foam panels can reduce the weight of conventional glass and infill panel systems by 60%, reducing construction equipment requirements and emissions in transportation.

A secondary concept that evolved with this system was a design for cam locks that could draw the panels against the floor perimeters of a building, compressing integrated gaskets around the perimeter of each panel. Additional locks could complete gasket seals at adjoining panels. Light weight, it turns out, creates the possibility of using such a mechanism; presumably these mechanisms would produce a continuously tight, thermally resistant envelope that could be easily modified or repaired by removing and replacing panels.

The final 1:1 prototype produced by the group used CNC-milled extruded polystyrene foam as the core of the panel, substituting actual structural foam with polystyrene with similar thermal properties. The panel varied in depth throughout its area, testing the groups assertion that this fabrication method would be conducive to applications where an 'active Z-axis' was useful either for structural, environmental, or aesthetic purposes. A single IGU was installed in the panel using structural sealant. Detailing around the IGU exhibited the group's solution to condensation risk at the perimeter of the glass, where thermal resistance would drop precipitously from the conductive glass to the jamb opening, resulting in a low-temperature line along the glass interface. The group solved this problem by creating a lapped area at the perimeter of the glass where it could be adhered directly to the panel assembly, reducing the number of parts required in the panel. The exterior of the panel was finished in heat-bent fiber-reinforced plastic and applied with a liquid adhesive; the interior was finished with maple-veneered plywood and is removable to access connections.

In the computer simulations (Table 1) and in real-world testing of the prototype, this system showed a very high degree of thermal resistance in comparison with other systems tested. This is not surprising because of the depth of the panel. Temperatures at the panel surface were nearly identical at the thinnest (4") and thickest (12") part of the panel, suggesting diminishing benefit of additional foam thickness beyond 4 inches. Coincidentally the glass IGU, a double-glazed Low-E unit, recorded colder temperatures than other glass in the test, suggesting the properties of the surrounding panel may actually be increasing heat transfer at the glass unit. Whole building energy simulations were then used to compare performance of the 24,000SF test building using this system versus the manufacturer's base system; calculating an aggregate U-Value for a composite wall of 25% glazing and 75% opaque infill, the building HVAC energy usage is reduced by 12%. The performance of this team's system is highly design-dependent and in a building where the spatial and functional impact of the wall is favored over glazing, greater energy reductions could be realized. Predictably, the monolithic nature of this system performed well in infiltration tests, showing no measured leakage at 50Pa (Table 3).

CONCLUSION: EVALUATING AND INTEGRATING PERFORMANCE

The research undertaken in the studio demonstrates first that high performing curtain wall systems like that produced by Manko are indeed very high performing, and their actual performance is perhaps not fully appreciated by the green design community. Given the ability of these systems to reduce building infiltration and prevent the unanticipated thermal failures of improvised opaque wall systems, these systems will continue to be useful systems in low-energy buildings.

That said, the three systems introduced in this paper all showed performance advantages over the base curtain wall systems. It should be emphasized as well that compared to typical curtain wall systems, rather than the high performing system from Manko, the margins of improvement would greatly increase. And while economics was not a part of the studios' analysis of experimental systems, it is probably that any of these three systems could be manufactured without greatly increased expense. It is also not out of the realm of possibility that any of these three systems could be proposed for a large project whose owner would support additional costs of development, and could be easily realized through direct collaboration between manufacturer, architect, and consultants.

A final conclusion can be made in related the studio to practice. In addressing the issue of performance in both a quantitative and qualitative manner, the students needed to embrace a more expansive body of 'base knowledge' about building physics as well as a science-based approach to experimentation. Performance outcomes needed to be objective, verifiable, relevant, and related to the comprehensive needs of real life projects. Knowing how to analyze designs was not simply enough – students needed to interpret the results. In summary of this point, the students needed to engage a deeper knowledge of building performance. Yet on the other hand, it was important for the students to maintain their design faculties during the work and not abandon the effort to work creatively and critically. This was important while the students were balancing

Table 2: 30-minute average temperature comparison

30-MINUTE AVERAGE TEMPERATURE COMPARISON			
	Measured Point	Surface T	$\Delta T = T_{int} - T_{surf}$
SYSTEM A	MFR middle mullion	57.3 °F	7.9 °F
	MFR glass, lower pan	57.9	7.3
	System A - middle mullion	50.2	15
	System A - Glass, lower pane	56	9.2
SYSTEM B	MFR Glass, Upper Pane	58.7	6.5
	MFR Middle Mullion	57.3	7.9
	MFR Glass, Lower Pane	57.9	7.3
	System B - Upper IGU	54.3	10.9
	System B - Middle Mullion	58.5	6.7
	System B - Polycarbonate, Lower Pane	59.8	5.4
SYSTEM C	MFR Glass, Upper Pane	58.7	6.5
	MFR Middle Mullion	57.3	7.9
	MFR Glass, Lower Pane	57.9	7.3
	System C - Upper IGU	52.7	12.5
	System C - Middle Wall	61.6	3.6
	System C - Lower Wall	61.1	4.1

Table 3: infiltration tests

INFILTRATION TESTS				
Configuration tested	Calculated @ 50 Pa	Calculated @ 75Pa	CFM per square feet* @ 50Pa	CFM per square feet* @ 75Pa
All systems masked - baseline	199.9	259.0	0.39	0.51
Mfr's Base System	0.1	0.9	0.01	0.06
System A: Structural Spacer	4.6	6.9	0.30	0.45
System B: Composite Node	2.6	4.3	0.17	0.28
System C: Foam Composite	0.0	2.1	0.0	0.13

*The area of each system tested for infiltration was 15.47 square feet. The total surface area of the test enclosure, minus the area of the systems, was approximately 512 square feet.

ACKNOWLEDGEMENTS

The author would like to thank Manko Window Systems and Kevin Dix, PE and VP of Manko, for generously working through the process of inquiry, design, and prototyping with the student teams involved in this research, and for providing the glazing components and glass for the prototypes.

Brian McKinney and Nadav Bittan, of BNIM architects in Kansas City, and Rick Shladweiler of PGAV architects in Kansas City also contributed their time and collaborative efforts for crits and reviews during the research process.

This research work was also sponsored by an NCARB Award for the Integration of Practice and Education. Funding from the award was used almost entirely for materials to build the test enclosure, for student prototypes, and for new equipment that supported this research.

Lastly, the author is indebted to the extensive efforts of the students involved, acknowledging the enthusiasm, curiosity, knowledge base, and persistence that are needed to bring serious research into the

design studio. The participating students were: Brian Conklin, Tyler Countess, Kate Gutierrez, Kristy Johnson, Cameron Marshall, Jose Martinez-Giron, Nick Nelson, Nathan Niewald, Alex Otto, Kevin Perks, Hanh Phung, Dylan Rupar, Lawrence Tan, Jenelle Tennigkeit, and Sammi Wai. The author would also like to thank the Department of Architecture and the College of Architecture, Planning, and Design for the opportunity to teach this funded studio.

REFERENCES

- ASTM C1046-95, 2013. Standard Practice for In-Situ Measurement of Heat Flux and Temperature on Building Envelope Components, ASTM International, West Conshohocken, PA, 2013, www.astm.org
- ASTM C1155-95, 2013. Standard Practice for Determining Thermal Resistance of Building Envelope Components from the In-Situ Data, ASTM International, West Conshohocken, PA, 2013, www.astm.org
- ASTM E783-02, 2010. Standard Test Method for Field Measurement of Air Leakage Through Installed Exterior Windows and Doors, ASTM International, West Conshohocken, PA, 2013, www.astm.org
- Boyle, Brian J., John Runkle, and Richard Ziegler, 2013. "Achieving Tight Buildings Through Building Envelope Commissioning." Proceedings of the 3rd AIVC Airtightness Workshop. Washington DC, 18-19 April.
- Brandt, Robert M., Gordon H. Chong, W. Mike Martin, 2010. Design Informed: Driving Innovation with Evidenced-Based Design. Hoboken, N.J.: John Wiley & Sons.
- Steven J. Emmerich, Andrew K. Persily, 1998. "Energy Impacts of Infiltration and Ventilation in U.S. Office Buildings Using Multi-zone Airflow Simulation." Proceedings of IAQ and Energy 98 Conference. New Orleans, LA.
- Steven J. Emmerich, Tim McDowell, Wagdy Anis, 2005. "Investigation of the Impact of Commercial Building Envelope Airtightness on HVAC Energy Use." National Institute of Science and Technology.
- Robert Davison, 1947. "Technological Potential in Home Construction." *Law and Contemporary Problems* 16-24.
- Yeomans, David, 1998. "The pre-history of the curtain wall." *Construction History*, Vol. 14, pp. 59-82
- Yeomans, David, 2001. "Origins of the Modern Curtain Wall." *Association for Preservation Technology Bulletin*, Vol. 32, No. 1, Curtain Walls.

ENDNOTES

1. The test enclosure was constructed using Bosch Rexroth aluminum structural components and enclosed using 3.5" Raycore SIP panels with polyurethane insulating cores. With an additional 0.75in of continuous insulation the envelope was increased to a thermal resistance of R 28.3 ft² °F hr/Btu. Interfaces between structure and envelope panels used gaskets that were compressed as panels were bolted together. All gaps were taped and any accessible gaps were filled with loose foam and backer rod. Prototypes installed over steel sill flashing and were separated by a block 2" of extruded polystyrene or 0.75" of expanded polystyrene, and all gaps were sealed with backer rod and silicon caulk.
2. Data collected during thermal tests referenced ASTM C1046-95 (2013) and ASTM C1155-95 (2013) but because of limitations, could not follow this standard entirely for calculating heat flux. Thermocouples were adhered to surfaces using aluminium tape spray-painted either black or white to eliminate effects of radiant heat loss on local temperatures. Data acquisition devices recorded synchronized data from all channels on a laptop computer at 5-second intervals. Individual thermocouples were calibrated using ice point calibration. Heat flux sensors were not available to the group, so individual temperature readings were used as an analogue for heat flux. This is possible because heat flow from conduction is equal to that of convection and radiation at these points ($q_k = q_c + q_r$). Radiation is negligible because of the nearly equivalent temperatures of environment and test surface and the reflective, foil-faced surfaces of the SIPs that reduce radiant heat transmission. Thus individual temperature readings indicate mostly heat transfer by convection ($q_c = h_c \cdot A \cdot \Delta T$), and given that all test points experience nearly the same heat transfer coefficient (h_c), we can regard the temperature differential (ΔT) as representing magnitudes of heat transfer per area (flux) among test points. For example, a 50% increase in ΔT suggests a 50% increase in heat flux.
3. Infiltration tests referenced ASTM E783-02 (2010). Following this standard, 'extraneous' gaps around each prototype were masked using masking tape to ensure only internal air leakage (around IGUs and in between frame connections) were measured. When a prototype was being tested, the other five prototypes were covered with 5 mil polyethylene sheet, taped to the exterior of the glass units. Data was recorded after the polyethylene sheet was 'sucked' to the surface of the other prototypes, indicating complete negative pressure was achieved inside the test enclosure. Testing used a duct testing apparatus joined directly to the test enclosure, and tests were conducted at 50 Pa and 75 Pa and used an average of three 120-second averaged recorded by the testing instrument.

RTKL's performance driven design: Lessons learned from the commercial practice

Pablo La Roche¹

¹RTKL Associates, Los Angeles, CA

ABSTRACT: Performance-Driven DesignSM (PDD) is a branded initiative that strives to improve the value of the built environment. It applies the greatest available intelligence to create compelling design with measurable benefits. This paper describes the implementation of Performance Driven Design in RTKL's commercial practice of the Los Angeles office. Because the commercial practice is very fast paced, and developer and market driven, there are more obstacles to implementing sustainable design in projects. The practice group has developed different techniques to facilitate the implementation of sustainable design in these different environments and scales.

KEYWORDS: Performance Driven Design, Simulation Tools

INTRODUCTION

To reduce anthropogenic emissions and have any real impact on climate change, it is necessary to improve building performance, reducing GHG emissions, energy and water consumption, and waste production. This paper discusses a general process that includes strategies, workflows and tools used in the commercial practice of RTKL's Los Angeles office to implement Performance Driven Design. Furthermore, the process is flexible and adaptable and can be adjusted to different scales and requirements.

PDD has been implemented in the commercial practice in multiple scales. Most of our projects are quite large, many times including multiple buildings. Ideally the process should flow from the urban scale to the building form, façade design, and then the fabric. However this does not always occur in all projects and sometimes the work is in neighborhoods, buildings, and interiors of buildings. The approach has always been to optimize the performance through the implementation of design strategies in at least several specific areas.

This paper introduces the firm wide initiative and briefly discusses two areas in which the author has participated, outdoor comfort and envelope design. Additional strategies have been implemented by the author and many design teams in other RTKL offices.

1.0 RTKL's PERFORMANCE DRIVEN DESIGN

By drawing on ample evidence about the economic, environmental, and social impacts of design, Performance-Driven Design (PDD) seeks to apply the greatest available intelligence to create uplifting places with measurable benefits to people, place, and planet. RTKL's PDD is a branded initiative that promises not just to improve the quality of the work but also to create a new standard for design excellence. Starting with each project's goals and continuing through its strategies and results, PDD can be adapted to the unique circumstances of any project and support the needs of project teams and clients. The goal is to encourage experimentation and freedom around a shared vision and set of values that unite all of RTKL's work.

Over these past years, RTKL has developed several resources to implement PDD. These provide support in the upfront development of the goals (The Smart Start), strategies to pursue these goals (the Dart) and mechanisms to document these results (the Dash). The Smart Start provides an online collaborative platform for design teams to meet and discuss goals and generate a vision that responds to client requirements. Users can collaborate online in many ways such as research and charrettes. The DART is an interactive tool that guides designers towards PDD and has three steps: first, the variables are identified, then the strategies are selected and finally an approach is proposed. Variables are selected and organized interactively in a website. The beta version of the DASH permits to record real building performance data in one location.

2.0 PERFORMANCE DRIVEN DESIGN PROCESS IN THE COMMERCIAL PRACTICE

Projects in the commercial practice move very quickly, driven by the developer and market forces, making it more challenging to implement sustainable design strategies in projects. To achieve positive results the commercial practice enhances RTKL's Performance Driven Design methods with several strategies, implemented using multiple tools in different scales and phases. These activities are directed to optimizing

specific areas of the project, such as massing and form, shading, window to wall ratios, skylight design, outdoor comfort etc. This has allowed the design team and the client to understand impacts of specific quantifiable benefits of implementation of the strategies, opening the door to the implementation of a stronger PDD in all areas: social, economic and environmental.

The activities in the process can be organized as a set of strategies that improve performance. Figure 1 describes the activities and the strategies in this process and how they are linked with the phases in the design process. The vertical columns indicate the phases: Conceptual Design, CnD, Schematic Design SD, Design Development DD, Construction Documents CD, Construction Administration CA, and Operation and Maintenance O&M. The horizontal bands are common PDD topics that designers deal with during the design process: site, envelope, light and energy. Rectangles in the intersection of these two are the strategies and processes that can be implemented in each area. These strategies and processes can take many forms and combine different analogue and digital tools most of them for simulation. It is thus possible to delve deeper into each of these “boxes” or combinations of boxes and develop very detailed workflows that include tools and activities.



Figure 1: Design Process with Strategies

3.0 SIMULATION TOOLS

The architectural design process is an iterative problem solving process in which sequences of sub problems that are not well defined are solved. During this process the documents to generate a building, which must satisfy many different criteria, are produced. Rittel proposed the existence of an alternating generation and reduction cycle, which repeats itself continuously improving design quality in each cycle (Rittel 1970) (Fig 2). This iterative process is key to correctly implementing Performance Driven Design, and for simulation tools to be well integrated in this process. Simulation tools are more commonly used as evaluation tools, but can also be used as generative tools to produce forms based on factors that optimize performance.

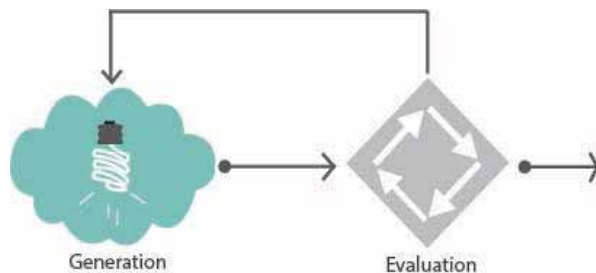

Figure 2: Generation/Evaluation of Ideas in Design Process (Source: Carbon Neutral Architectural Design, La Roche)

of Very Simple Design Tools (VSD Tools) that would be easy and simple to use, so that more designers could use them affecting more buildings (La Roche and Liggett 2003). Simulation tools are also CAD tools in the broad sense because they improve the quality of the final product through digital simulations. They are an important part of our performance driven design process and when used in the evaluation portion of the generation-evaluation cycle they help to quantify the effect of different design decisions, providing valuable feedback to project teams. They should be implemented as early as possible in the process and implementation should continue during all design phases.

Typically when we describe simulations we refer to them as simulations for design performance and simulations for code compliance. Simulations for design performance are done to quantify several parameters, some of which might not be required by code. In addition to energy, simulation modelling includes the measurement of many other variables which also provide useful information and facilitate design decisions. Some of the most common in our practice are insolation analysis on building and ground surfaces, illuminance and luminance levels in interior spaces, airflow in outdoor spaces, and energy consumption. Results of these simulations affect glazing to wall ratios, window design, shading systems, etc. The goal of simulation for design performance is to enhance the design by integrating performance attributes in the design, enhancing it. Modelling for code compliance is typically done for energy consumption, and due to the complicated nature of our projects in our practice is usually done by consultants. It compares the calculated energy use of the designed building with a reference baseline building to demonstrate that it complies with minimum performance criteria.

We like to initiate simulations as soon as possible in the design process. Feedback is less useful when simulations occur late in the process. However, we believe that it is never too late and it is always possible to implement design strategies that will improve project performance. Clear and visual communication of the results is also crucial to provide adequate understanding to the rest of the project team and the client. Finally, simulations must be useful. Analysis for the sake of analysis should not be done, there must be a possibility to respond to the analysis results and some time for after processing. Simulations should only be done if they will inform design decisions or if they are needed to demonstrate compliance.

4.0 OUTDOOR COMFORT

4.1. IOI Palm City, Xiamen

Xiamen is a Chinese port city with a monsoonal humid subtropical climate (Köppen Cfa), characterized by long, hot and humid summers, but moderate compared to much of the rest of the province, and short, mild and dry winters. A detailed climate analysis was performed to determine the effect of the key parameters that affect energy consumption and thermal comfort: Dry Bulb Temperature, Relative Humidity, solar radiation and wind speed and direction, in addition to the activity level and clothing. Figure 3 shows two of these, DBT and RH on a yearly basis.

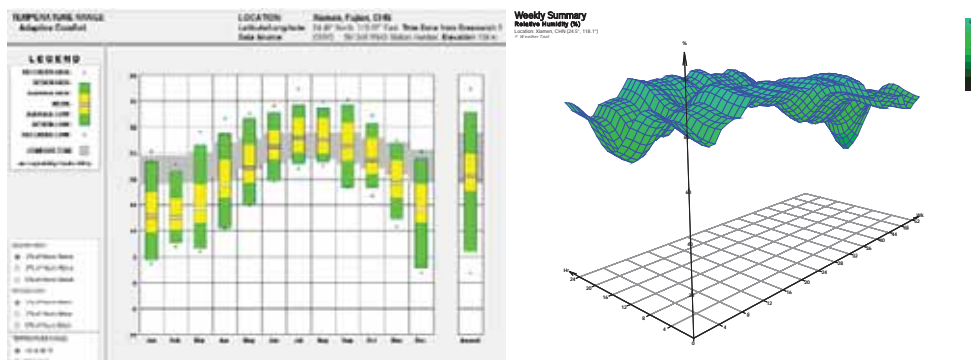

Figure 3: Annual Temperature and Relative Humidity in Xiamen

There are several indicators that can be used to determine thermal comfort. One of them is the Predicted Mean Vote, PMV, which considers human and environmental variables: Activity (met), Clothing (clo), Air temp. (°C), Mean radiant temp, affected by long wave, diffuse and direct solar radiation (°C), Air speed (m/s), and relative humidity (%). The comfort model using PMV works well in buildings with HVAC systems, but occupants in naturally ventilated buildings are tolerant of a significantly wider range of temperatures. This is explained by a combination of both behavioral adjustments and physiological adaptations. These effects are incorporated in a revision to ASHRAE standard 55 in 2000 and is valid only when the monthly mean outdoor temperature is between 10 °C (50 °F) and 33.5 °C (92.3 °F). Thus, standard 55 which was originally solely based on the PMV model now has an optional method for determining acceptable thermal conditions in naturally conditioned spaces. The standard states that occupants' thermal responses in

naturally conditioned spaces depend in part on the outdoor climate and may differ from thermal responses in buildings with centralized air conditioning systems. This is due to the differences thermal experiences, changes in clothing, availability of control options and shifts in occupant expectations. The neutrality temperature in this model can be calculated using the following correlation:

$$T_n = 18.9 + 0.255 A_{T_{out}}$$

Where:
 $A_{T_{out}}$: Outdoor average effective temperature
 T_n : Neutrality Temperature

Even though adaptive comfort has been developed for indoor comfort, it can also be used to a certain extent, for outdoor comfort. Assuming there is shade and air movement, comfort can still be achieved during 61% of the period from June to September between 10 AM and 10 PM, (80% acceptability limits) (Fig 4).

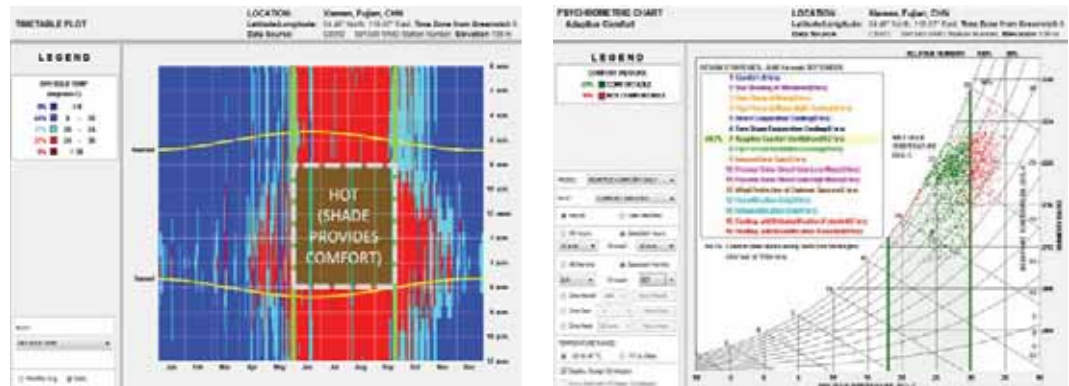

Figure 4: Analysis Period in the Timetable plot and Adaptive Comfort from June-September, 10 AM to 10 PM.

The recommended outdoor comfort strategies in the summer are to provide air movement to promote evaporative cooling in the skin and shade to reduce effects of longer wave radiation. An important outdoor feature in the project is a curved south facing outdoor plaza with dining terraces. These terraces will be shaded with canopies thus reducing solar radiation to the body. To determine the effect of wind a 3d wind tunnel analysis with Vasari, using the smallest possible grid, was performed using predominant wind directions to determine if there was enough air flow at the level of the human body. Multiple slices were analyzed and results indicate that there is not enough air velocity at the terrace levels (Fig 5).

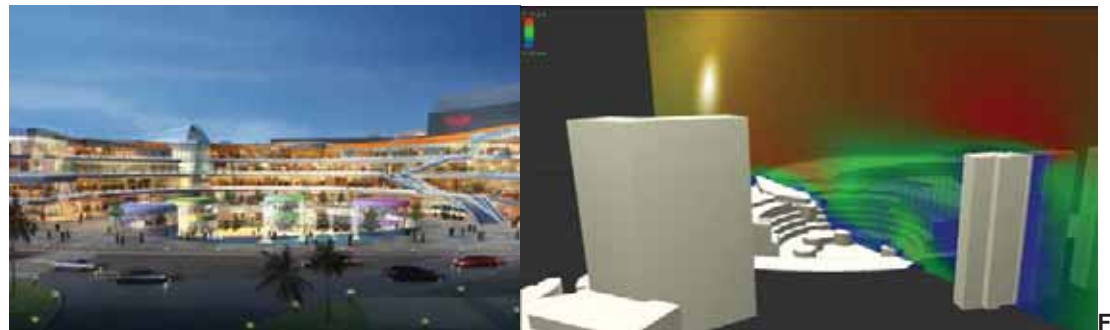

Figure 5: Summer simulation at section terrace. Wind from south, 5 m/sec (18 km/hr)

To increase the airflow in this outdoor area, the exterior wall of the entrance towards the center is converted into a solar chimney by adding a double skin façade towards the front (Fig 6 left). This idea was tested by CTL-E Corp using a CFD program. Site wind speed was set at 2 m/sec and wind from the south. Results indicate that the double skin provides improvement compared to the entrance with no double skin, increasing wind at lower level from about 0.2 m/s to 0.3 m/s. This option will perform even better if the solar chimney is widened to double the size increasing to 0.45 m/s (Fig 6 right) or at least doubled in size at the bottom (image not shown). This means that if air movement is increased and shade is provided through the canopies (not shown), comfort will increase.

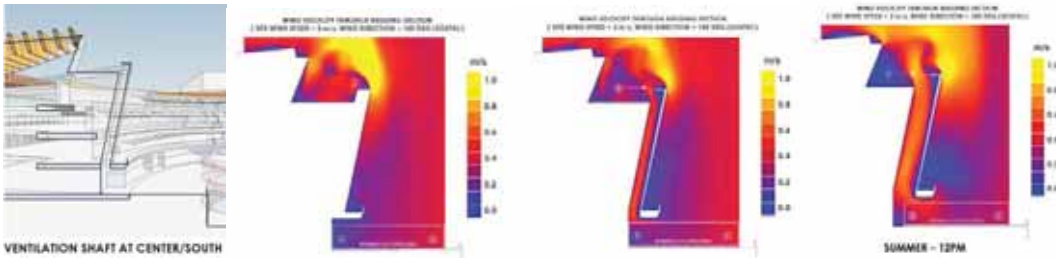

Figure 6: Ventilation shaft at center of south terrace. CFD simulation with no double skin

4.2. Case study Eden City project

This is a mixed use project that includes many themed activities in outdoor settings. PDD was integrated in the master plan phase. The fact that the client wanted to develop an outdoor mall in a location with a cold climate provide a challenge and the priority was to provide maximum outdoor comfort during the different seasons, especially during the cold winter in central China.

Figure 7 is a workflow diagram that illustrates the outdoor comfort analysis process in this project. Overheated and under heated periods are determined with climate analysis, and different tools help to generate guidelines that subsequently inform the project. These design concepts were evaluated with simulation tools and thermal stress calculations to determine problem areas. Finally solutions were proposed to address them. This process of generation and evaluation of solar and wind ideas was repeated as the project was developed during the the master plan phase.

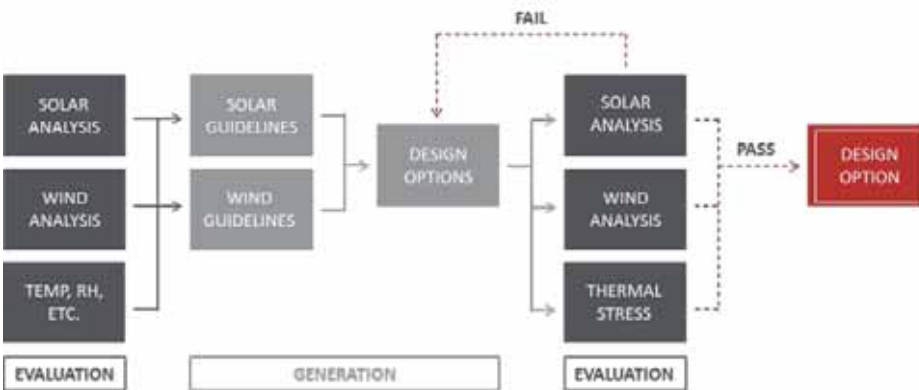

Figure 7: PDD process for outdoor comfort

Solar and wind recommendations effectively guided the design team in this process. To achieve comfort during the cooler period (October to March) solar radiation had to be promoted in outdoor spaces to increase Mean Radiant Temperature while cool winds had to be blocked. Four orientations were studied: north-south, and rotated 15, 30 and 45 degrees (Fig. 8). Glazed atrium spaces are also proposed as part of an outdoor network in which pedestrians can enter at different points to find places of refuge and warmth. A distance to height ratio of 1.8 was proposed to ensure sufficient solar radiation in outdoor spaces with lower altitude winter sun (Fig 9).



Figure 8: Outdoor solar analysis: four orientations in Eden City Mall



Figure 9: Solar guidelines from analysis

The Universal Thermal Climate Index, UTCI, developed by the European Union is a thermal stress index for outdoor spaces. According to the developers, after accessible models of human thermoregulation were evaluated, the advanced multi-node 'Fiala' thermoregulation model was selected, extensively validated, and extended for purposes of the project. In the next step a state-of-the-art adaptive clothing model was developed and integrated. This model considers (i) the behavioural adaptation of clothing insulation observed for the general urban population in relation to the actual environmental temperature, (ii) the distribution of the clothing over different body parts providing local insulation values for the different model segments, and (iii) the reduction of thermal and evaporative clothing resistances caused by wind and the movement of the wearer, who was assumed walking 4 km/h on the level (Journal of Thermal Biology 2003).

Research has found agreement with this standard and the use of outdoor spaces in China, further strengthening the reasoning to implement this indicator in China (Lai et al 2014). Preferences in solar radiation, wind speed, and relative humidity were related to air temperature. The higher the air temperature was, the higher the wind speed and the lower the solar radiation and relative humidity desired by the occupants, and vice versa. The data were also used to evaluate three indices. The Universal Thermal Climate Index (UTCI) satisfactorily predicted outdoor thermal comfort, while the Predicted Mean Vote (PMV) overestimated it. The neutral Physiological Equivalent Temperature (PET) range found in this study was 11-24 C, which was lower than the ranges in Europe and Taiwan. The neutral physiological equivalent temperature (PET) range found in this study was 11–24 °C, which was lower than the ranges in Europe and Taiwan. That study indicated that residents of Tianjin were more adapted to cold environment.

Thermal stress was calculated in this project using UTCI at 3 PM in January, March and April. Consistently there was less thermal stress with more solar radiation and less air movement during this period, demonstrating that a reduced outdoor thermal stress could be achieved in the winter by increasing solar radiation and reducing air velocity.

Table 1: Thermal Stress at 3 PM during three dates and under different conditions.

Date	<i>condition</i>				
	<i>Sun & no wind</i>	<i>Sun & low wind</i>	<i>Sun & wind</i>	<i>Shade & low wind</i>	<i>Shade & wind</i>
<i>January</i>	12.3	7.9	-4.4	0.3	-13.1
	No thermal stress	Slight cold stress	Moderate cold stress	Slight cold stress	strong cold stress
<i>March</i>	18	15.3	6.4	10	1.4
	No Thermal stress	thermal stress	Cold Stress	Thermal Stress	Cold Stress
<i>April</i>	21.3	19.3	12	14.3	7.2
	No Thermal Stress	No Thermal Stress	No Thermal Stress	No Thermal Stress	Slight Cold Stress

5.0 BUILDING ENVELOPE

Integrated analysis of the envelope includes the analysis of components as a function of solar gains during peak cooling loads, summer and winter, daylight (luminance and illuminance) and energy consumption. This integrated analysis process can be used to study different envelope components, for example window and shading options to select the best overall solution.

A typical workflow for envelope analysis is indicated in Fig 10. The first step is also to calculate the effect of the environmental variables in the determination of overheated and under heated periods. There are several options to determine these periods, degree days, upper and lower comfort ranges or using a simple energy model. Appropriate climate responsive design strategies are also selected using multiple resources such as Climate Consultant and the 2030 Palette. A façade insolation study permits to quickly determine critical orientations (Fig 11) and determine vertical and horizontal shadow angles for them and generate shading options (La Roche, 2011). These options are then tested using different simulation tools for insolation (Fig 11), daylight levels, glare and energy use such as Ecotect, IESve, COMFEN. These can be further refined and then re-evaluated. Alternatively, the designer must go back one or more steps to the design of the shading options or the calculation of the system.

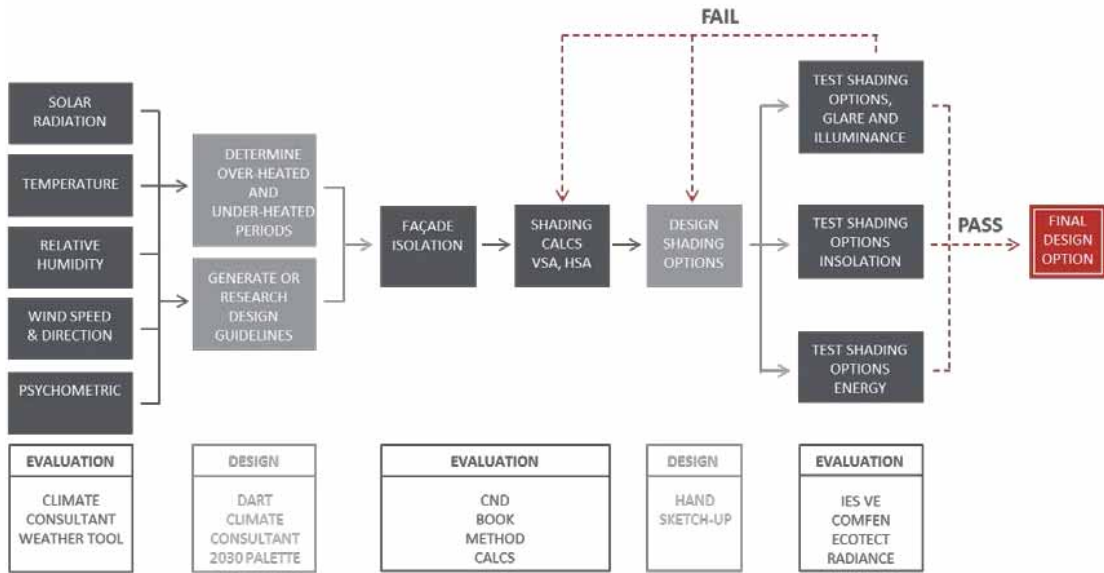

Figure 10: Envelope/shading workflow

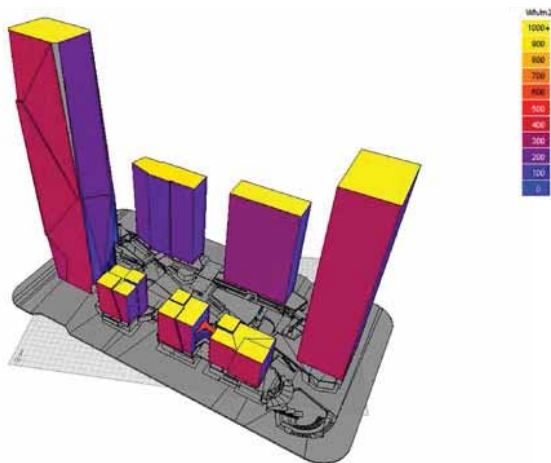

Figure 11: Envelope Insolation, Guangzhou poly mixed use project

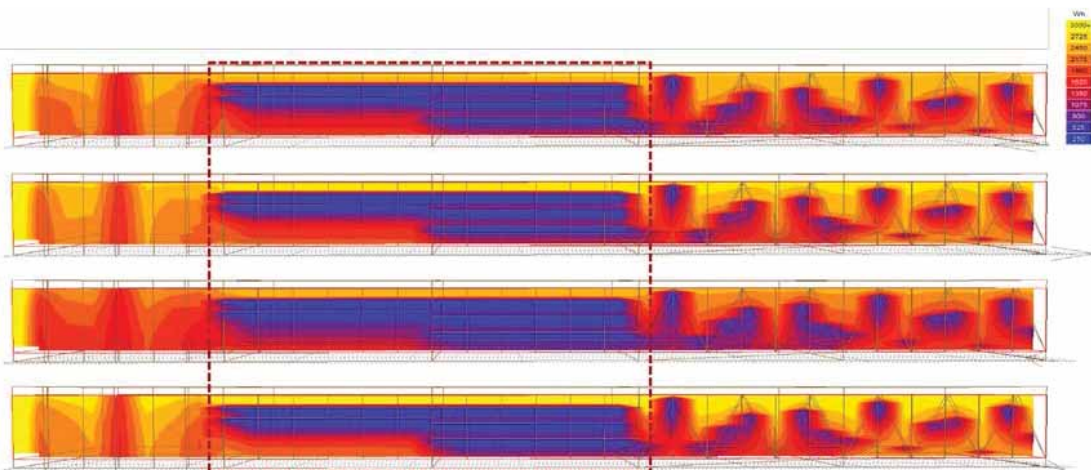

Figure 12: Insolation evaluation of several shading alternatives. Mega Kuningan mixed use project

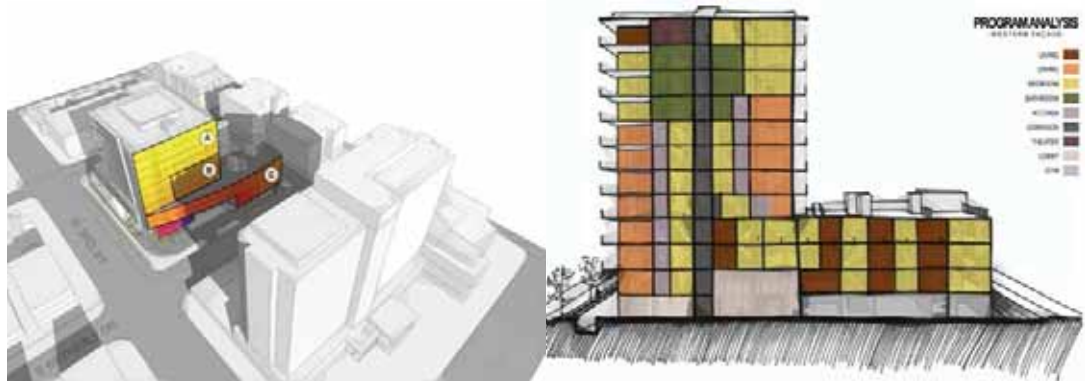

Figure 13: Insolation and programmatic evaluation of West Façade Wetherly Residences

For the Wetherly residences in Beverly Hills, an insolation analysis of the west façade during the cooling season (April 1 to October 31) divided it in three areas that receive different quantities of solar radiation (Fig 13 left). Even though this shading effect from neighbors cannot be considered in energy modelling calculations, it can be used to differentiate this facade in three areas that require maximum, medium and reduced solar control. Various options were tested to analyze the effect of the angle and the levels of solar radiation in the western façade and optimize the inclination of the fins to reduce solar radiation while maximizing the view and privacy. All of them were above a minimum value. A shading matrix was developed that spatially referenced the program facing the façade (Fig.13 right) with the insolation level. Specific solutions were proposed for each of these combinations.

CONCLUSION

Commercial developers will typically implement environmental strategies that have economic payoff. By focusing PDD on improving building performance in key areas and quantifying this performance it has been possible to implement PDD in the commercial practice and impact specific areas of multiple projects in a short time. It has not yet been possible to develop a project in which there are significant quantifiable benefits in all PDD areas: social, economic and environmental. Ultimately, buildings should have a reduced environmental impact measured by how they affect climate change and resource consumption; promote human health and quality of life, and benefit society while providing added value to the community. Building performance is measurable using appropriate metrics for each of these areas.

ACKNOWLEDGEMENTS

The work presented in this paper is the result of the collaboration between many RTKL staff members.

REFERENCES

- Dayi Lai, Deheng Guo, Yuefei Hou, Chenyi Lin, Qingyan Chen. 2014 *Studies of Outdoor Thermal Comfort in Northern China*. Building and Environment Volume 77, July 2014, Pages 110–118
- Glossary of Terms for Thermal Physiology*. 2003. Journal of Thermal Biology 28, 75-106
- La Roche P. Liggett R. 2001. *Very Simple Design Tools: A web based Assistant for the Design of Climate Responsive Buildings*, Architectural Science Review 44, 437-448
- La Roche P. 2011. *Carbon-Neutral Architectural Design*, CRC Press Taylor Francis 328 p
- Rittel, H. 1970. *Some Principles for the Design of an Educational System for Design*, Design Methods and Theories 20, 359-375.

A methodology of building performance analytics within high-performance design

Amanda Stacy¹

¹WSP, Washington, DC

ABSTRACT: “A methodology of building performance analytics within high-performance design” explores a framework for addressing excessive global energy consumption by synergizing metric-driven analysis with the traditional design process to create a truly sustainable architecture.

Global energy consumption steadily rises each year at the cost of non-renewable resources. Commercial and residential building sectors comprise a large portion of the global energy requirement; therefore the design industry has the opportunity to impact the future of energy consumption rates. A major contributor to the high rates of energy consumption is the desire to condition building spaces for optimum occupant comfort sourced by great amounts of grid-supplied electricity. However, the ability to heat, cool and light spaces can be supplemented with naturally occurring climate conditions which require no electricity. The utilization of solar, wind and precipitation factors into a series of energy saving strategies, such as Passive (requires no energy), Behavioral (requires human effort), Renewable (creates energy from natural sources) and Active (uses energy efficient systems) applications can significantly reduce the current rate of energy consumption within buildings.

Traditionally, these energy saving strategies are applied late in the design process with a basis on theoretical convention. By implementing a methodology of building performance analytics early on, energy saving strategies can be substantiated with metric-driven data to illustrate optimized energy performance. Building performance analytics focus on themes that range from incident solar radiation, shading, daylighting, window flow and conceptual energy analyses. These metric-driven analyses complement the traditional energy modeling process by optimizing form-based and passive aspects of the architecture prior to the analysis of active systems. The data that is derived from these analyses will pair with a comprehensive qualitative analysis in the design process to satisfy both performative and experiential desires.

In order to investigate the potential of integrating building performance analytics within the traditional design process, a case study design was developed for a mixed-use, high-rise building in New York City. New York City is the largest metropolis within the United States, which is the top global ranking country for the worst energy consumption per person. It also shares a similar climate type with approximately 50% of the most populous global cities. Therefore, a case study based in New York City demonstrates the need for improved energy efficient designs and the potential for future deployment and global benefit. The case study was designed and optimized within its particular climate zone, site context and building program through the utilization of sustainable design strategies and tested through a methodology of building performance analytics. The analytics studied both the overall building mass and individual residential units for a multidimensional approach to high-performance design. The product of the study was a schematic building design that ensured exemplary energy performance combined with an illustrious experiential quality. However, the most important outcome was a methodology of building performance analytics that can be fully integrated into an iterative architectural design process with the capability for adjustment depending upon project and programmatic desires.

Bridging the gap: Transparency in building materials

Suzanne Drake¹, Michel Dedeo²

¹Perkins+Will

ABSTRACT: In creating our Transparency list, we researched chemicals that are harmful to human and environmental health, to find those that are used within our sphere of influence – the building materials we as designers specify. We identified 25 items that have the most information available on potential health effects, but that do not have readily-available alternatives that designers could specify. Of those 25 items, flame retardants were the category that required in-depth research. With an input from chemistry expert, we intended to bridge the knowledge gap between the chemicals in building materials and the designers and architects specifying them. Future steps include continuing collaboration between design professionals and chemical engineers.

Dynamic solar design

Heath May¹

¹HKS LINE

ABSTRACT: Optimization of solar performance in buildings, using software for simulation and analysis of solar heat gain and daylighting, represents a way to leverage computational power in the process of design. Existing software packages offer the ability to simulate daylighting and solar radiation of a building space, but these packages lack key functionality that limits the applicability of the software-based simulation to the architecture design process. Writing custom software applications for our design process and methodology has allowed HKS LINE to implement dynamic solar design within the timeline of projects with large scope and great complexity. By using custom software applications with multi-threading capability, we can run multiple simulations concurrently and log individual datasets, enabling us to feed analysis information directly back into a parametric model for generating optimal geometry solutions. This workflow reduces the time requirement for accurate daylighting and solar irradiation simulation, enabling rapid optimization within the project design schedule.

Fundamental science building research

Leo Alvarez¹, Dan Watch¹, Mark Joyner¹, Regal Leftwich¹

¹Perkins+Will

ABSTRACT: The Fundamental Science Building in Doha Qatar will serve as laboratory for more than just innovative research by the scientists using the building. Research projects will be evaluated and studied as part of the actual building and landscape design. The condensate will be integrated into hydrothermal cooling features in the landscape that moderate the outdoor temperature and make the most out of the limited water resources. Lushly planted indoor and outdoor spaces will create "oxygen gardens" where oxygen production is maximized. Dynamic high bay spaces and work place environments to engage the end users will also be evaluated for their benefits.

Integrating the sustainability tracking, assessment and rating system (STARS) into the campus master planning process

Elizabeth Turner¹

¹Perkins+Will

ABSTRACT: Campus Master Planning is an ideal time to holistically integrate sustainability strategies into institutional development priorities. However, many obstacles exist that prevent successful integration. This Innovation Incubator is developing an interactive activity to for use during meetings with Campus Master Planning Committees to raise awareness and generate ideas to improve campus sustainability. The activity will be engaging, accessible for people with varying levels of sustainability awareness, and provide value to campus planning outcomes. Research includes interviews with planners and higher education staff, analysis of AASHE's STARS, and testing game play to develop an engaging and productive activity.

Mission zero corridor

Elizabeth Ward¹

¹Perkins+Will

ABSTRACT: The Mission Zero Corridor project aims to reframe one of the most pervasive, impactful and ubiquitous pieces of infrastructure in our society, the highway, into a tool for cultivating a more sustainable future. MZC aims to be a model for the world's first restorative transportation corridor – where its systems, elements and policies actually repair the environmental and social degradation historically associated with highways. The project develops a framework for highways to do three primary things: unify, restore and catalyze. The framework provides communities, around the nation and the world, a model for reimagining transportation corridors more broadly – as conduits for connectivity, pollution remediation, resource generation and efficiency, wildlife conservation and migration, human health and safety, and for purposes that we cannot yet imagine. Ultimately, Mission Zero Corridor is a tool for education, awareness and promoting and catalyzing real change.

Salahaddin University in Erbil

Jimmy Smith¹

¹Perkins+Will

ABSTRACT: “If Afghanistan was the primary school for terrorists then Syria and Iraq is a University for them.”

-Sheik Khalid Al Khalifa..., G-4s Security Services Chairman for Bahrain.

This quote speaks to the vital importance of education as perhaps the only long term effective means to fight the extremist indoctrination that is taking hold of much of the Middle East. For the past two years I have spent the last two years travelling back and forth from the USA to Erbil, Iraq, helping to plan and design a campus University for the Iraqi Khurdistan: Salahaddin University- Erbil (SU-E). During the short time I have spent travelling to Erbil the events that have taken place continue to strengthen my conviction about the potential importance of Salahaddin University Erbil to Iraqi Kurdistan and to the region at large. I would like to share some of the design decisions that emerged from our work and research with the client as well as to share my insights into the thought process out of which the design emerged. It is my hope that some of the decisions our team have made in shaping the campus design that I will share at the ARCC convention will have the intended positive impact on the education of its students in years to come.

The new campus for SU-E sits on a prominent site within the city of Erbil. Erbil is the capital of and commercial center of Iraqi Kurdistan. At the very center of Erbil is the Citadel, located along the original silk route to the Far East. The Citadel is over 8000 years old and its resident's claims to be the oldest continuously inhabited community in the world. As a major center of trade Erbil has a long and proud heritage as a center of tolerance and the open and free exchange of ideas. It is in that spirit of openness that SU-E engaged our firm to help plan a curriculum and design campus both from scratch within the city of Erbil bringing together the latest thinking in Western higher education in order to fuse together 12 dispersed colleges into a singularly integrated and multidisciplinary academic community for 40,000 students. SU-E will be roughly the same size of the larger state Universities in the USA. The goal for the University is for SU-E to become both a wellspring of knowledge and a beacon of hope for Iraqi Kurdistan. In these few short years I have witnessed tremendous changes, economically, socially, culturally in the region that has experienced tremendous trials and undergone transformations for many millennia. Many of these factors, totally unanticipated have had their impact on our mutual design efforts.

Over the past two years as I have grown far more aware of the deep seated plight of the Iraqi Kurds and their continued struggles for autonomy. The Kurdish people are the largest nationality in the world without a nation and they are set within a region of instability and intolerance. I am dismayed by how little we in the West understand their plight. Even more disturbing is the lack of understanding of just how important these displaced people are to establishing stability within a region in turmoil. As an architect it has been enlightening to be engaged with a community in a times of crisis and to be part of shaping their campus and its curriculum. Our mutual efforts emerged from the rich and intense dialogue between contemporary Western academic concepts and a Kurdish culture with truly ancient roots. The discourse began and continues to be open and honest yielding results. Program and curriculum has influenced design and design has shaped programming. Out of the effort has emerged a plan for a dynamic interdisciplinary University that is infused with much of the latest in Western academic thinking (open western influenced University campus planning/design), while reflecting the influence of Kurdish and Middle Eastern culture.

Sponge: A new technology for performative surfaces

Inanc Eray¹

¹Inanc Eray Architects

ABSTRACT: The future of architecture relies on not designing buildings, but designing intelligent and integrated systems that simulate the multi-purpose mechanics in nature. Architects and developers have to find materials and technics to implement biological logic to achieve sustainable, durable and multi-functional building components and systems. The design of advanced materials, with the goal of obtaining responsive environments, plays an imperative role in creating buildings of the future. With this notion in mind, this presentation explains our firm's study on a super-hydrophobic and super-porous carbon sponge material (the Sponge), developed at the labs of University of California, Riverside to find out the material's architectural applications allowing performative and sustainable systems. The Sponge technology separates oil-based contaminants from water, with an absorption capacity of 10 to 50 times of its weight, depending on its microstructure. It is highly sustainable with the capability of being used more than 20 times for filtration and contaminant absorption without any significant change in its efficiency. The technology is designed to be cost-effective, with its main precursor being sugar. We are currently analyzing the interaction of Sponge with various construction materials to potentially eliminate conductors, insulators and additional waterproofing layers from building surfaces. We are also studying its post-construction and maintenance applications, as the late studies of the material show ferromagnetic effects, which allow different disposal and recycling methods. The preliminary results show that the technology can build removable and reusable layers that function both as insulation and waterproofing. We are continuing an in-depth study on its conductive and ferromagnetic implications with the aim of expanding the functionality of the designed surface. The potential future applications of the material and its applications on building technologies will also be presented.

Tall wood | The obstacles of perception

Shawna Hammon¹

¹Perkins+Will

ABSTRACT: Wood is increasingly becoming a viable material for high rise buildings. However, despite the fact that wood has a lighter environmental impact than today's typical high rise construction materials, it faces many obstacles, not the least of which is public perception. The purpose of this study is to identify the barriers of perception through a survey of the public and the different stakeholders of tall timber. Once these obstacles have been pinpointed through the data, this proposal will provide the evidence-based foundation to a larger study that focuses on overcoming these perceptions.

The innovation incubator: Micro-grants and a culture of innovation

Leigh Christy¹, Diana Davis², Mark Walsh³, Brian Weatherford³

¹Perkins+Will, Los Angeles, California

²Perkins+Will, Atlanta, Georgia

³Perkins+Will, Chicago, Illinois

ABSTRACT: Perkins+Will's Innovation Incubator program was established in 2010 with the goal of helping to foster a culture of innovation, creativity and exploration within our practice. The presenters of this presentation co-created the program, and continue to lead the program for the firm. Using the Kiva microfinancing model as inspiration, the Innovation Incubator encourages an entrepreneurial spirit within the firm, thus not relegating innovation to a small group of people, but rather empowering all staff members to seek opportunities for exploration in their work.

The objective of this presentation is to explore how relatively small investments in an individual's or team's creative ideas can lead to significant results without negatively impacting – indeed, positively supporting – a private design firm's productivity, profitability and culture. The Incubator program's structure, organization and processes are explained, along with the lessons learned in its first five years of existence.

Administered by a firmwide "Innovation Project Committee", a bi-annual online application process allows potential "Incubator Project Participants" (individuals or teams) to receive "micro-grants" of money and/or time to create or accelerate the development of innovative methodologies, collaborative research endeavors, special technical expertise, or other forms of intellectual capital that reinvigorate our practice in a relatively autonomous way. "Incubator Office Champions" offer inspiration, guidance and support at the local level for the selected Project Participants and ensure project results are disseminated. Each grant is a maximum of 40-hours and \$1,000 in reimbursables per individual, or 80-hours and \$2,000 in reimbursables per group. The Incubator program budget is set annually and tracked monthly.

In the Incubator's five years of existence, we have held ten bi-annual calls for entries, over 300 project applications, and over 100 project awards. Individual projects have led to breakthroughs in understanding environmental factors that contribute to exacerbating PTSD in veterans, advocating for reintroducing the street car to downtown Los Angeles, constructing a prototype parklet in San Francisco, building a successful case for applying nontraditional methods of bringing daylight into an urban infill project in Boston, and creating an interactive digital toolkit for gathering pre-occupancy information in a workplace environment. Current explorations involve testing virtual reality as a design communication tool, contributing to the emerging dialogue on tall wood buildings, researching correlations between health indicators and location, and creating a computational database of renewable energy incentives in support of Net Zero Site Energy Design.

The program intent is to spark innovative thinking in the form of focused, nimble explorations rather than to support extended research projects. Many times, however, the process does not end with the completion of an Incubator project. Frequently, these "micro" projects are connected with promising academic or nonprofit partners with which to apply for external grants, or shifted into Perkins+Will's nonprofit arm "AREA Research" for further development, or adopted by the firm as tools or methodologies to employ on our projects. All results are distributed internally and many are also disseminated externally through websites, conferences, papers, and research journals. The staff response has been overwhelmingly positive.

UCSF School of Medicine [SoM] workplace research project

Janice Barnes¹

¹Perkins+Will

ABSTRACT: In the summer of 2014 UCSF SoM commissioned a workplace research project to assess a range of indicators of productivity, satisfaction, and well-being prior to and following a move into the new Mission Bay Block 25-A Academic (Office) Building (Mission Hall). The focus of this study is an evidence-based design approach to understanding the best ways to support the UCSF faculty, staff and students through an Activity-Based Work [ABW] environment. In collaboration with Dr. Nancy Adler, Dr. Jean Wineman and Dr. John Peponis, the team completed IRB review, developed a pre and post occupancy workplace research protocol and are in the process of concluding the post occupancy research. Results will contribute to the future development of workplaces on the UCSF campus and ultimately through a longitudinal study, contribute to the broader challenges faced by universities that are examining the various ways to accommodate workplaces that optimize new ways of working and support academic needs. Final results will be ready by summer of 2015.

Using field research + parametric analysis to inform medical planning & design

Upali Nanda¹

¹HKS+CADRE

ABSTRACT: A lot of research has been done on healthcare facilities and a substantial evidence-base is in place. Yet, for every new project, owner and design teams spend an extraordinary amount of time to determine the right configuration, frequently starting from scratch. Although research is considered important, it becomes less “relevant” in the course of the project based on a lack of sync in research and project timelines, and the challenge of contextualizing existing research to the current project scope. In this presentation we will share the development and deployment of a field research + parametric analysis module called a “design diagnostic” that was developed to assess on-site conditions (based on observed, reported and spatial data) and inform the planning and design of the Med-Surg and ICU of a new medical tower. Findings from the research study showed that current work processes were sub-optimal, in part due to the spatial configuration that caused large distances for relatively minor tasks. The research also showed that point to point distance (summarized via a heat map) had to be put in the context of the frequency and sequence of key activities. Design teams used information from the field research, and the parametric analysis of walking distance and visibility, to develop unit configurations, which were then tested in a full-scale mock-up during design development.

RESEARCH AND
EDUCATION
IN ACADEMIA

Architecture at the edge of practice: A pedagogical approach to social architectural education

Nkemakonam P. Okofu¹

¹Sheffield School of Architecture, University of Sheffield, UK

ABSTRACT: This paper explores the concept of practice at the edge of architecture as a learning matrix which reveals the tension lying beneath the surface of social architecture practice. A concept that operates beyond the iconic, the office architectural practice to a more ethical resilient, vernacular, bottom-up approach to future practice.

Further to explore how practice at the edge of architecture influences a pedagogical model for social architecture practice and education. A detailed reflection on students' and tutors' field experience in a recent community study of Okuku community in South-East Nigeria by groups of third year architecture students using an integrated design (IDS) approach. This approach to architecture design pedagogy immerses the students into the community as a way of understanding the needs and prospects of the community. Employing participatory action learning approach co-creates and co-produces multiple-authorships as intervention strategy that attempts to provide solutions within the same context.

KEYWORDS: Pedagogy, Practice, Resilient, Social Practice, Community

INTRODUCTION

There is a growing criticism that schools of architecture are rarely preparing students to the contemporary challenges of social architecture practice. The criticism accentuates the point that architecture as a profession has over time distanced itself from engaging in social issues even those within the ambit of its professional engagements¹. The debate is currently centred on how best to educate the next generation of architects who will not be equipped with the needed tools and skills to address social, political and environmental challenges but be influenced by them.

The 'radical contingency of architectural practice' demands new form of pedagogy not new form of knowledge as new knowledge becomes obsolete over a short period of time while innovative pedagogy explores new and alternative ways of solving problem².

This paper explores critical reflections on students' and tutors' experiences working in rural communities within the contested territories of the global South through an action-learning (AL) approach as a part of Integrated Design Studio (IDS) model undertaken by students of architecture in Imo State University, Owerri-Nigeria. IDM is a form of live project model; the idea of this model is predicated on the philosophy and objective of the department of architecture Imo State University to produce future Architects capable of understanding societal need for shelter, and translating this need into climatologically appropriate environments which should be able to satisfy the social, cultural and economic aspirations of society in the local, national and regional context³.

The school seeks to achieve this objective through carefully graded modules (reinforced by appropriate lecture courses) which are based on thorough study of communities. Through critical observation, surveying, documentation, analysis and synthesis of their needs in terms of planning, design and construction, special attention being paid to graphic, oral and technological proficiencies⁴.

1.0 PRACTICE AT THE EDGE OF ARCHITECTURE (EDGE PRACTICE)

The role of the architect is changing and a recent report on *'The Future for Architects'* by Building Future Think Series⁵ opines that specialization has become the hallmark of the new roles involving strategic and global interdisciplinary consultancies, risk management, BIM experts, spatial agency, and project management amongst many (Jamieson 2011:12).

The contingency of architecture practice in attaining to the complexities of the contemporary society calls for a new form of practice not bound by institutional hegemony of mainstream practice (Hyde 2012). Rory Hyde opines that a new form of practice is emerging at the edge of traditional practice that show uncommon potentials for future practice as he states:

There are designers around the world eagerly carving out opportunities for new kinds of engagement, new kinds of collaboration, new kinds of practice and new kinds of design outcomes; overturning the inherited assumptions of the design professions (Hyde 2012:20).

'Practice at the edge of architecture' is a term the author uses here to describe emerging practices that sit beyond the boundaries of mainstream practice that involves the participation of both architects and non-architects. This term was influenced by Dan Hill in his contribution to 'Future Practice: conversation at edge of architecture' (Hill, 2012). However, what has been largely overlooked is the value each player brings into the design process, which is the key to a more balanced resilience in social architectural practice.

This form of practice tends to synthesize a sense of community and mediation that lies beneath the threshold of a single professional discipline. This practice promotes interdisciplinary collaboration, entrepreneurship, strategic thinking, community enabling, spatial agency, and place-making amongst others. Beyond the accompanied diverse skills and knowledge in edge practice, it is also underpinned by following discourses: '*Architecture is too important to be left to architects.*' (De Carlo, 1970; Blundell Jones, Petrescu, Till, 2005); '*Architecture is far more than the work of architects.*' (Hill 2003).

It is within this point that this paper situates and explores 'practice at the edge of architecture' as a learning matrix that seeks to respond to the complexities of social challenges within the contested territories of the Global South in the form of a community intervention. The idea behind this approach to practice and learning suggest that architecture practice could be more socially-minded while engaging people in that context towards solving problems without necessarily playing by the rules of professional ethics. Hence edge practice does not only provide alternative to mainstream practice but reveals the tensions that lie beneath the surface of architectural practice through spatial agencies, and seek a more ethical, bottom-up, vernacular-based and locally resilient approach to future practice.

Nicholas Ray raises an ethical question about the work of the architect whose concerns and interest are built around aesthetics and building appearance than the social and environment concerns. As quoted by Ray:

'For too long architectural discourse has been limited largely to a question of aesthetics itself, as though architecture were some autonomous art form which stand outside the constraints of capitalist production.' (Ray 2005).

The notion of 'practice at the edge of architecture' agrees with the philosophy of Cedric Price who opines that not every process of architecture leads to a building as a product⁶. The above premise situates edge practice as a form of intervention whose pedagogy is structured towards inculcating into students the values for community and civic action in providing solutions to problems. The role of the architect becomes a mediator or spatial agent who assists communities to evolving. It is important to state that those operating inside the edge are the architects while those outside the edge are non-architects, other professionals, civic society, and community members⁷. The questions that this form of pedagogical practice raises are what should students learn and which skills are increasingly important to have in order to rise to the many challenges social architects face in practice? These questions became the underlying principles of IDS pedagogy.

2.0 INTEGRATED DESIGN STUDIO PEDAGOGY

The department of Architecture Imo State University Owerri-Nigeria has since its inception in 1992 operated Integrated Design Studio model in teaching and learning architectural design at the core of its curriculum structure. The department seeks to produce architects whose role in this transition requires the right attitude of mind which recognizes design as a holistic developmental process requiring integration of several disciplines and sympathetic understanding of the needs of the society⁷. The above philosophy of the school is linked with the general objective of education of the federal republic of Nigeria that states:

- Reforming the content of general education to make it more responsive to the Socio-economic needs of the country;
- Consolidating and developing the nation's system of higher education in response to the economy and manpower needs. (FGN 1975).

The scope of IDS community study is graded into rural, semi-urban, and urban communities involving students in Yr.3, Yr.4 and MSc1 respectively. Most examples and inspirations are drawn from Rural Studio University of Auburn (USA), Live Project University of Sheffield, (UK).

2.1. Methodological approach to integrated design studio (IDS) pedagogy

IDS-pedagogy was remodelled recently by a research team in the department led by the author. IDS is driven on the premise of 'experiential and situated learning; which is substantially appreciated when learning is done in real time in real context (Lave and Wenger, 1991; Sara, 2004). The design module for IDM is mapped into five stages namely:

- Documentation

- Analysis/Synthesis
- Planning and Proposal (land-use and master plan)
- and Demonstration/Construction

Students are taken on a three weeks tutorial lectures and seminars showing the basic processes of conducting the fieldwork exercise, methods of data collection and presentation, ethical procedures in dealing with members of the community, mapping of possible strategies to reflect ideas each member brings into the group project, updating existing map(s) of the study area. A formal reconnaissance of the study area is done with tutors and the students in an arranged meeting with the community representatives. A community is selected for study by the tutors based on population, evidence of informal settlement, lack of government presence, low standard of living, absents of basic and social infrastructure. The study last for one academic year of two non-contiguous semesters, but within the first semester students are expected to document and analyse their finding while synthesis, proposal and demonstration is done in the second semester. At the end of 4 weeks students are expected back in the studio to document and analyse all the data collected through observation, interviews, questionnaire, photographs, mapping local concerns.



Figure 1: Okuku communit study through ids (2012) -source (integrated design studio 2012, 3rd year undergraduate students).

Fig. 1 shows the state of existing facilities in Okuku community where students identified the poor state of roads, dilapidated school facilities and the nature of open spaces while opportunities like arable farmland, settlement patterns,

2.2. Group project: Okuku community study

Okuku is a rural community in Owerri-West local government area of Imo State in South-East Nigeria with a population of 3,124 inhabitants in 2012, and a distance of 2.5km away from the capital (Owerri) yet far from development⁸. The community was inaccessible to the outside world due to the effect of erosion and flooding.

2.3. Study objective

The study was set to explore how architecture can create social intervention in an informal settlement through multiple authorships and co-production of knowledge.

2.4. Group task

A total of thirty students registered for the IDS community project were zoned into five groups saddled with following task.

Group 1: Physical Context- This group's task involved locating the community within the regional context using maps, climatic conditions (temperature, humidity, rainfall, wind direction), topography and drainage systems, erosion issues, geology (soil types, soil bearing capacity), vegetation cover and their characteristics, fauna (animals and pests). Most of the data the group deals with are obtained through referencing existing literature while base maps are updated through observation and reconnaissance.

Group 2: Social Cultural and Economic Context- This group documented issues on historical origin of the community, cultural practices, settlement patterns, demographic data (age/sex, labour force, household sizes). Bye-laws, employment/occupational classifications, industrial base (types of industries, small/medium scale), services, agricultural activities etc.

Group 3: Housing- The task includes understanding and observing settlement patterns, housing policies, housing stock, housing demand/supply, housing typology, condition of buildings, building services, open spaces, land tenure system, household size, building conservation/preservation.

Group 4: Social Infrastructure- students in this group classify and document the hierarchy of schools (nursery, primary, secondary, vocational/technical) their locations, population, staff strength, area served, churches/mosques/town hall, health centres, leisure (sources of entertainment and recreation, festivals, swimming, football, lawn tennis).

Group 5: Physical Infrastructures- Modes of transportation, road network system, traffic volumes, public parking spaces, classification of vehicles in respect to road carriages, water supply and demand (sources of water), energy (types of energy, different sources of energy, demand and supply of energy), communication (means of communication, -telecommunication), firefighting measures, sanitation system, refuse disposal methods, existing land use pattern, physical constraints (flooding, erosion prone areas, rivers/lakes, overhead high tension cable), opportunities (waterfall, fertile soil, cultural heritage sites) that can be developed.

2.5. Project phases

Phase I- fieldwork (physical, economic, and social survey). Every group defines the study area, collect and document data.

Phase II- Analysis/synthesis of data: Students are expected to state the goals and objectives of the study, further researches are done to establish the basic standards and tools for analysis, where the data collected are weighed against minimum standards from literature.

Phase III- Planning and programming: Analysis/synthesis are articulated to build up a conceptual scenario towards realizing the set goals and objectives of the project and as such the students' philosophy and conceptual structured plan are concretized in real terms through building up flow charts, bubble diagrams, space matrixes, tables that will form the proposed action plan.

Phase IV-Design Project: The design proposal is made after careful analysis and synthesis through planning programming that highlights the basic needs of the study area and possible architectural design solutions graphically demonstrated in the master plan proposal.

The study outcomes, students' and tutors' reflective experiences will be discussed under the themes below.

2.6. Documentation and analysis

Documentation as Ukanwa defines it in relation to architectural design as:

"The collection of relevant data in respect of any given program and consequent presentation of such data in the acceptable architectural means of communication." (Ukanwa, 2004:19).

Analysis: The documented problems in the form of data are further broken down into their various parts to make sense of each element as they are appraised to ascertain their conformity, non-conformity, deviation, potentials, and challenges based on acceptable standards, rules, laws and policies (Ukanwa, 2004).

Based on the reports of the groups the following social and environmental challenges were identified:

Lack of access roads, lack of adequate primary health centre, existing primary was oversubscribed with paucity of adequate facilities, lack of basic social amenities (electricity, pipe-borne water), poor building orientation, low roof pitches, devastating effect of erosion among others.

My experience living and learning in an informal settlement through this community study created in me a sense of responsibility and the tenacity to be part of a solution haven't experienced the depth of problems in their real state that are challenging communities. This experience is better achieved when you immerse yourself as part of the community (from a Yr.3 IDS student's reflection, 2012).

The student groups analysed and synthesized the earlier documented observable challenges in the form of data that was presented to the community to enhance a better understanding of the challenges, prospects and possible solution.

2.7. Planning and proposal

Collaboratively, the students outlined the following planning strategies:

- The need to build a primary health centre that is capable of providing the basic healthcare needs of the community.
- Analysis shows that most roads in the community were oriented against the contours which subject the roads to constant wear by run-off water causing flooding. A re-alignment of the roads in the direction of flow was suggested.
- A new primary school to be built while the existing facility will be upgraded new primary school and the upgrade of the existing facilities as they are being over-subscribed in terms of human and material resources. This was done from analytical point of view that in the next 10 years the population of people within primary school age currently at 341 will be 513 and as such 172 pupils will be displaced or denied access to school within the period in view.

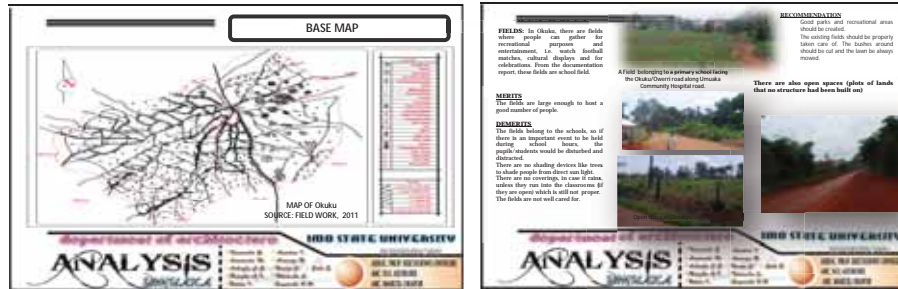

Figure 2: Students documentation/analysis report. (source: okuku community ids group fieldwork, 2012).

4.0 OPPORTUNITIES/ LEARNING OUTCOMES

The students observed the presence of a continuous flowing water body in the form of a stream at the lower end of the community which they proposed could be potentially developed into a waterfront resort that can serve as some form of tourist site.

The students analysed the existing land-use pattern and observed 2/3rd of the land mass predominantly used for agricultural activities and further investigation reviewed that the community's major occupation is farming. They propose for some form of mechanized agricultural activities for investors.

The settlement pattern tends to support a communal settlement morphology where people live in clusters and have common open spaces used for multi-functions (meetings/communal activities, recreation, cooking and storage units). The housing group proposed a low-income house type informed by the settlement pattern and cultural identity that will be built with local available building materials.

The idea behind this model is to develop students' critical thinking and creative ability to conceive and test design ideas in real time with real problems through a co-production of knowledge with the community. This unique pedagogical opportunity inherent in IDS model is argued to weigh beyond those simulated in the design studio. The project was not aimed at design-build model but rather provides a tangible working solution for the community and a tool for learning within the context of informal rural settlements. As part of work in progress the author is currently working on obstacle to social architecture which is hope will provide a framework for sourcing funds that will enable IDS research network execute future proposals.

5.0 REFLECTION

Building relationship with people you work with, taking responsibility and making decision that might even lead to failure is crucial for a learning process (Achipovaite, 2014:128).

5.1. Students' reflections

Students' reflecting on their experiences in the community study using IDS model shows how students became much aware of how their environment can influence their thought process as they became part of the community. Adopting ethnography enriched the quality of factual data students obtained in the process of immersing themselves as part of the community which built trust and confidence on the part of the community.

As we engaged more in the study the more we understood the problems and conceived great ideas within the context, the fast our preconceived ideas get eroded or better shaped while our thinking becomes more clearer (from a Yr.3 IDS student's reflection, 2012).

The group work developed the students' collaborative skills as they understand and see how other member of the group view and approach problems. Working collectively as a team reflects activities that occur in practice.

Students are in control of their learning while taking important decisions in the project. This approach supports Webster case for students centred learning as against tutor centred learning pedagogy which she argues allow the students to dictate how and what inform their learning in the 21st century (Webster, 2004). The impact of working with the local community members exposed the students to immense wealth of local knowledge in terms of understanding local building techniques, crafts, sustainable local materials, local tacit knowledge of climate and seasons as it relates to agricultural activities etc.

The memories of contested spaces and tentative interventions provided within the same context remained mapped in my mind; this is a valuable asset that will be used for future scenario. This became my most memorable experience of the fieldwork (from a Yr.3 IDS student's reflection, 2012).

My hunch for community design project grew stronger after watching a presentation by the tutor of a typical community intervention project in a riverine slum community in Makoko Lagos-Nigeria by architect Kunle Adeyemi of NLE' who designed the Lagos Floating School. It became clear that

architecture in the midst of ecological, social and environmental challenges facing communities can provide intervention as a sustainable bridge (from a Yr.3 IDS student's reflection, 2012).

5.2. Tutors' reflections

Part of what we learnt from this approach to learning was first, the accelerated rate at which students understood and attempted to proffer solutions based on a clear sense of sight, this affirms to what Skotte emphasizes about experiential learning 'the way we learn is not by being told but by being part of' (Skotte, 2011:42). While facilitating this learning process, students' reflection on their experience become more like a teaching aid for subsequent fieldwork and also serves as some form of feedback towards improving the model. Students' assuming the role of professionals also challenges them beyond their own actions to being aware of the ethical and professional implications of their engagements and also developing a tradition of becoming social architect (Archipovaite, 2014).

6.0 CHALLENGES OF IDS APPROACH TO LEARNING

Over the years IDS and similar approaches to learning have being proved to be a viable tool for learning and intervention within informal settlements in the global south but funding support is being a great challenge to adopting this approach in a wider scale. Greater part of the design proposals have only ended up as academic documents and action- working documents for the communities without being constructed. The structure of academic calendar of the university challenges the sustainability of IDS as students are also made to offer other theoretical modules while reducing the amount of time dedicated to the fieldwork. High rate of insecurity in Nigeria in the form of kidnapping, religious crises, youthful unrest, terrorism attack in recent times are on the rise.

CONCLUSION

Ukanwa argued earlier that integrated design studio (IDS) model equips students with the ability to identify architectural design job opportunities in the communities and create architectural design projects therefrom rather than waiting in the office for client's commissioning⁹.

Practice at the edge of architecture draws the notion that architecture (in the form of spatial agency) could mediate those forces that condition architecture practice in a more culturally and socially resilient way and stimulates intangible future values in community practice. Edge practice creates potential for interdisciplinary practice, engaging beyond a single disciplinary practice to a more resilient hybrid practice. IDSM brings democratization into the social relationship between members involved in the process to create some form of fluidity in the power dynamics where students, tutors (facilitators), and community members who get involved in taking decisions concerning them. IDSM is research oriented and promotes research-in practice that is currently at the fore front of architects' professional body in the United Kingdom¹⁰.

This approach to practice in no doubt develops students' skills and knowledge in project planning, analysis, communication, architect-client relations, and environmental consciousness. IDS-model creates a spring board to future research since it approach to data collection involves a methodological process of documentation, analysis/ synthesis in creating a coherent proposal which is not only a contribution to knowledge but a social intervention.

REFERENCES

- Archipovaite, E. 2014. From studio to the field: learning and teaching in context. AAE 2014 conference Proceedings, University of Sheffield, UK, pp. 126-129.
- Blundell-Jones, P., Petrescu, D., & Till, J. (Eds.). 2005. *Architecture and participation*. Taylor & Francis.
- De Carlos, G. 1970. Architecture's public. *Journal of Environment* (3).
- Federal Government of Nigeria, FGN 1975: *Third National Development Plan, 1975-1980*, Vol. 1, The Central Planning Office, Federal Ministry of Economic Development, Lagos.
- Hill, D. 2012. *Future Practice: conversation at the edge of architecture*. New York: Routledge.
- Hill, J. 2003. *Actions of architecture: architects and creative users*. Routledge.
- Hyde, R. 2012. *Future Practice: conversation at the edge of architecture*. New York: Routledge
- Jamieson, C. 2011. Future for Architects. Building |Futures, [online] available at <http://www.buildingfutures.org.uk/> (assessed 6th March 2014).
- Lave, J., & Wenger, E. 1991. *Situated learning: Legitimate peripheral participation*. Cambridge University Press.
- Ray, N. (Ed.). 2005. *Architecture and its ethical dilemmas*. Taylor & Francis.
- Sara, R. 2004. *Between Studio and Street: The Role of the Live Project in Architectural Education*, PhD thesis University of Sheffield.
- Skotte, H. 2014. Teaching to Learn- learning to teach learning experience from reality of an ever-changing world. In *Alternative development: unveiling marginalization, voicing change*, Brun C., Jones M. Blaikie P. Farnham: Ashgate.

- Ukanwa, O. E. 2004. Integrated Studio method as a sustainable architectural module: procedures, prospects, and problems. *Journal of Association of architectural educators in Nigeria (AARCHES)*, vol.3 no.1, pp. 17-22.
- Webster, H. 2004. The design Diary: promoting reflective practice in the design studio. Paper presented at the EAAE transactions on architectural education. Architectural design: monitoring architectural design, Greece.

ENDNOTES

1. Crawford, Margaret. Can Architects be Socially Responsible? In Ghirardo, D (Ed.). *A Social Out of Site Criticism of Architecture*. Seattle, USA: Bay Press. 1991. pp. 27-45.
2. Till, Jeremy. Lost Judgement. In: E. Harder, ed. *EAAE Prize 2003-2005 Writings in architectural education*. Copenhagen: EAAE. 2005. pp.164-183, [online] available at: http://www.eaae.be/old/web_data/documents/ (accessed 6th September 2014).
3. Architectural Design II Programme (Arc.311) of the Department of Architecture, Imo State University Owerri. 2011/2012 academic session.
4. See 3 above.
5. Building Future Think Series published a research conducted in 2011 to inquire about the changing roles of the architect and explore the future trend in the profession with the research question of what will those trained in architecture be called in the next 20 years? see details on <http://www.buildingfutures.org.uk/projects/building-futures/>.
6. Cedric Price (1934-2003) was an architect whose philosophy and ideology questions how architecture was being associated with building as an end product and used 'as a means of consolidating power' but he was of the opinion that architecture should be conceived as some form of interventions, flexible and adaptable. See Price, Cedric. *Cedric Price*. [London]: [Architectural Association]. 1984.
7. Hill, Dan. Forward. In: Hyde, R., *Future Practice: conversations from the edge of architecture*. New York: Routledge. 2012. pp. 7-15.
8. IDS-Project (Yr.3 Department of architecture, IMSU-Owerri): Okuku community study. 2012
9. Ukanwa, Emma. Integrated Studio method as a sustainable architectural module: procedures, prospects, and problems. *Journal of Association of architectural educators in Nigeria (AARCHES)*, Vol.3 no.1. 2004. pp. 17-22.

Beyond tutorials: Using active learning to improve computational design instruction

Nick Senske¹

¹University of North Carolina at Charlotte, Charlotte, NC

ABSTRACT: This paper describes the development of an introductory computational design course for architects that uses active learning practices to improve student outcomes and engagement. The author presents results from a four-year impact study. Student performance improved with the introduction of active learning methods, specifically: peer learning labs, scaffolded design projects, and shorter lectures coupled with group discussion activities. In addition, students reported an improved perception of computing and an increased interest in the subject – a positive outcome for a required introductory course.

KEYWORDS: Education; Active Learning, Computational Design, Computing

1.0 INTRODUCTION

1.1. A required course for teaching computational thinking

In 2011, UNC Charlotte began integrating computational design throughout our curriculum. One of the core principles in this effort is the promotion of computational thinking in all courses and studios¹. Computational thinking is an idea that originates from computer science, but has relevance to architectural design. To offer a simple definition: it is a mindset that helps one make the best use of humans and computers to solve complex problems (Wing 2006). Because this mindset is not limited to any particular tools or domains, we believe it can provide our students with a computing foundation that is both flexible and robust. Thus, to introduce our students to computational thinking, we teach a foundation-level course entitled *Computational Methods*.

A major premise underlying *Computational Methods* is that computational thinking is a form of literacy. This has two important implications. The first is that understanding computation and being able to express oneself computationally is not optional for architects anymore. Communicating and experiencing the world via computing is akin to reading and writing: it is a fundamental means of participating in today's profession and society in general. As such, *Computational Methods* is required for all our students and is a prerequisite for other computational courses (such as BIM, digital fabrication, etc.) later in the curriculum. The second implication of literacy is that computer programming is an essential skill. Using software is only reading it; a literate person must also be able to write (Kay 1993). Thus, learning to program (in some form) is also a requirement within our curriculum. This process begins in *Computational Methods*.

1.2. First iteration: traditional tutorials and lectures

The earliest version of the course (Fall 2011) devoted a majority of class time to tutorial-based labs. Students learned software (Processing and Grasshopper, in this instance) by watching the instructor and following along on computers in the lab. Later in the weekly lesson, the students attended a lecture, where the instructor summarized the week's concepts and discussed the connections between the tools and architectural theory and practice. The majority of assignments in the course were design-based. Students would be given some simple computational design parameters (e.g. create a visual composition using a nested loop) and asked to generate a design to demonstrate their understanding. A final, comprehensive project assessed students' ability to synthesize what they learned in the course. This pedagogy (or something similar) is common in many computing courses.

Unfortunately, the students' initial response to the course was below our expectations. In their semester evaluations, many complained that they found the pace and complexity of the material overwhelming. Because they struggled to make their scripts work, they could not come up with ideas for what to make. As a result, their design assignments suffered, as well. Even more concerning was that students did not find the course relevant to their professional development. They felt that learning programming was an unnecessary skill and they should be learning BIM instead. Despite our efforts to communicate the broad applications of computational thinking to their education, the students were unconvinced.

In response to these results, we set out to study the problem. Why was student comprehension low and why did so many fail to see the connections between the material and their work? Furthermore, what changes

could we make to our teaching methodology to improve student outcomes?

1.3. Confronting the challenges of teaching computational thinking

Although today's students spend much of their time using computers, this does not necessarily make them sophisticated users. Educational research indicates that learning computation presents a significant challenge for most people. In particular, learning to script can be difficult. Even expert computational designers admit as much (Burry 2011). But, in architecture, it can be hard to prove that an educational gap exists. Aside from Mark Burry's survey of practitioners in [Scripting Cultures](#), we could find no empirical research on the problems architects face when learning computation.

Educational research on novices and non-majors learning to program shows that scripting is a challenging and complex cognitive activity (see a summary in Dalbey and Linn 1985). Learning a computer language is not the primary cause of these challenges, as many believe. Rather, the more difficult task is learning to think like a programmer (Winslow 1996). This appears to be a problem that applies to architects as well as those studying to be professional programmers. Our earlier research found that architecture students exhibit many of the same problems reading and writing programs that have been documented for novice computer science students (Senske 2014). Thus, how to teach computational thinking effectively is a problem that overlaps computer science and architecture, with many unanswered questions and opportunities for research.

1.4. Active learning

Introducing computation through traditional educational methods like lab tutorials and lectures may not effectively engage students to overcome these difficulties. Research suggests that instructors need to take into account differences in student learning styles and attention spans (Bransford et al. 2000). For most students, the passive consumption of content in school (e.g. how to use software) is not interesting. Worse, these lessons tend to impart brittle knowledge and skills which are quickly outdated. In architecture school, design projects are supposed to help students synthesize and critique what they study, but these may be inappropriate and counter-productive when students have only a superficial grasp of computation in the first place. Educational research suggests a different path towards helping students become better computational designers: active learning.

Active learning encourages students to play an active role in their own learning process: discussing, evaluating, and collaborating rather than merely listening and following along with instructions. It can help students develop a deeper understanding of complex subjects by engaging them in a peer-driven process of knowledge discovery, problem-solving, and critique (Prince 2004; Bonwell & Eison 1991). Instead of expecting students to make sense of computation by attempting to use it to design too early, this method is highly structured and promotes understanding by helping students become better learners. This is a more productive, sustainable goal than merely being a competent software user. The ability to learn computing better and apply it with a critical attitude can help students now and in the future as they adapt to technological and professional changes.

The remainder of this paper presents the introduction of active learning into Computational Methods and the results of a four-year study of its effectiveness. By sharing our rationale, course structure, and lessons learned, we hope to establish a model others can follow as they look for ways to effectively teach computation to a large and diverse audience.

2.0 BEYOND TUTORIALS

2.1. Second iteration, and beyond: active labs, scaffolded design, and active lectures

Computational Methods is a required foundation course for both graduates and undergraduates. It convenes in the fall term and meets twice a week for one 50 minute lab and one 75 minute lecture. The average course size is about 75 students, with a typical proportion of roughly 60% undergraduates to 40% graduate students.

The course syllabus is designed to introduce topics in a manner that carefully builds complexity and connections between each lesson. Many computing courses are structured around particular commands or tropes, which can lead to rote learning. In contrast, examples of *Computational Methods* topics include: abstraction, data structures, debugging, conditional logics, and problem solving with algorithms. These topics are not limited to a particular software implementation. Rather, they represent the "big ideas" of computational design. In addition, we frequently repeat concepts from week to week so that students have the opportunity to revisit them in different contexts. This is an application of the "spacing effect" in learning, which is said to improve comprehension (Dempster and Ferris 1990).

2.2. Flipped classrooms

In order to free up class time and resources to introduce active learning in the classroom, we restructured the way materials are presented to our students. Our tutorials and lectures are now available as online videos. This allows students to learn and review this material at their own pace, rather than the instructor's. With the additional time, we transformed our course schedule, teaching methods, and assignments to improve how students learn, practice, and form critical perspectives about the material. In practice, our teaching methodologies resemble a “flipped” classroom (Tucker 2012), where the students complete homework-like activities in class and watch videos of tutorials and lectures outside of class. Now that most of the content of the course is delivered outside of class, we use class time to synthesize, correct misunderstandings, and discuss the material.

2.3. Active labs

An example of one of these activities is our “active” lab, where students drive their own learning process. We use a form of peer instruction (Crouch and Mazur 2001) rather than the typical instructor-focused model. Before the lab, the students receive a tutorial video as homework. They watch the video to learn skills and concepts that will prepare them for the lab. When the students come to lab, instead of merely following the instructor (which would be a passive lab) they work with a partner on a self-directed “lab report”. The report is similar to a science lab prompt, where the students are asked to construct, modify, and experiment with various computational systems (Figure 1). The students are presented with prompts to experiment with a system, answer questions about what they see, and use this information to understand the system and generalize conclusions.

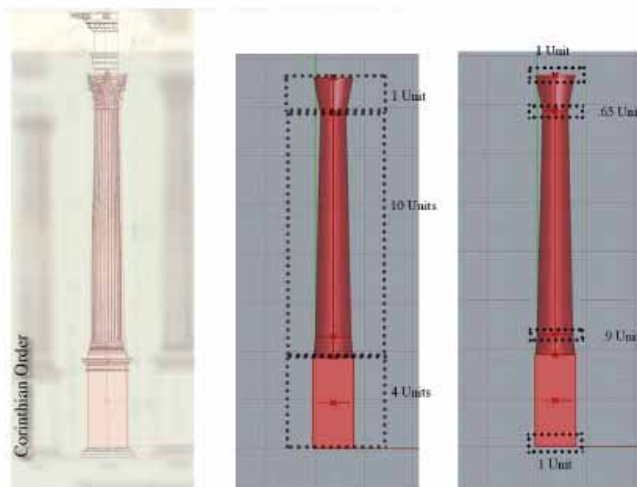

Figure 1: An example from an active lab report. In coordination with their history course, students diagram the proportions of Greek orders. These measurements form the basis of a column script that teaches the students how to create dependencies between geometric elements. The final script allows the students to study the orders while teaching them the power of parametric relationships. Source: (Author 2012)

2.4. Pair programming

Students work together in pairs on their lab reports, with one student scripting and the other guiding the process, frequently switching throughout the hour. This practice, known as pair programming (Figure 2), helps students manage the complexity of scripting and has been shown to improve both programming performance and enjoyment (McDowell et al. 2002; Nagappan et al. 2003). The instructor interacts with the pairs as a “coach”, providing assistance and motivation where needed, but the students manage their own time in the lab. In general, the active lab requires students to engage in problem-solving and experimentation rather than merely following steps and learning software commands. The idea is for the students to ask and answer critical questions about how computational processes work. Our methods encourage students to develop computational thinking and allows instructors to more effectively assess that thinking.

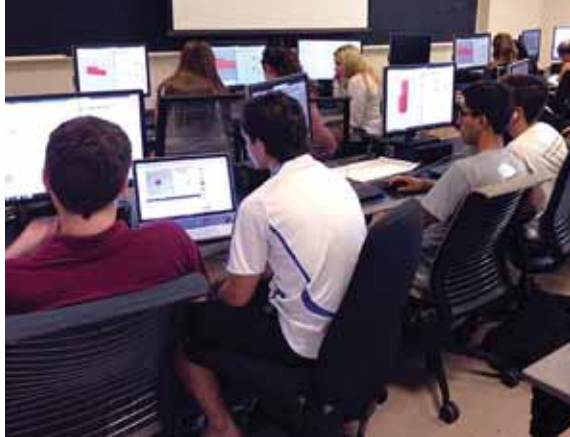

Figure 2: Left: An “active” lab session featuring pair programming. Source: (Author 2014)

2.5. Scaffolded design projects

The lessons in *Computational Methods* feature less design than one might expect for an architecture course, but, based upon our experience, we believe that other forms of practice and assessment are more appropriate at this level. Design projects assume students can synthesize skills and ideas on their own, but may be inappropriate for novices who have an incomplete understanding of the material. Indeed, asking students to generate original computational designs too early may encourage rote thinking, as production does not necessarily require comprehension. Therefore, instead of traditional design projects, we assign “scaffolded” projects. Scaffolding is a practice wherein the instructor models a complex activity while providing pedagogical support for the students to approximate that activity (Collins et al. 1990). Over time, the support is removed and the student performs the activity on their own (hence, the scaffolding).

One example of a scaffolded project is a parametric precedent study (Figure 3). Instead of asking students to design something on their own parametrically, we guide them through a process where they reverse-engineer a complex form derived from a built project. In addition, the students learn to document and present a parametric process so that it is understandable to a non-computational audience. Scaffolding reduces the cognitive load for the students, so they do not have to recall so many commands or infer too much beyond what they know (Paas et al. 2003). They still have to investigate the precedents, experiment with solutions, and implement a final design – this is the “active” pedagogy at work – but the progression and goals are clearer than in many computational design prompts. Educational research suggests that, for novices, practicing knowledge is more beneficial than struggling to synthesize and generate knowledge (Collins et al. 1990). The use of scaffolded projects supports the critical inquiry we promote through the active labs, while providing students with the opportunity to express themselves

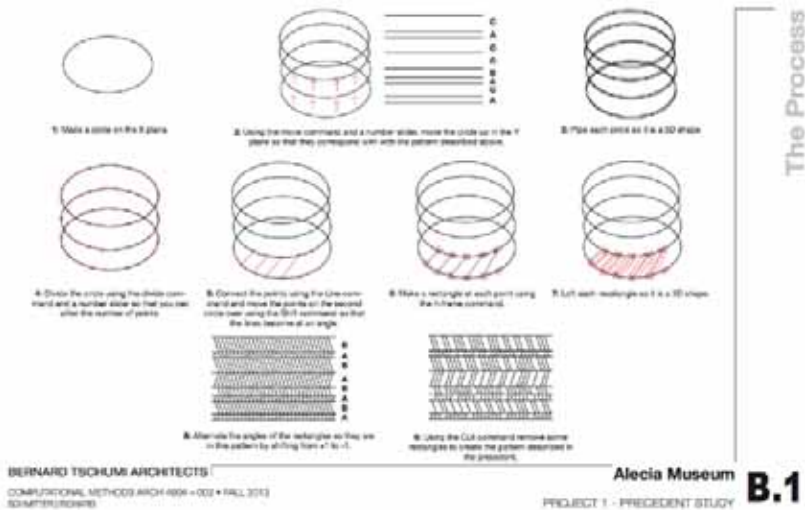

Figure 3. Assignments emphasize clear communication of process and computational ideas. Screen captures of scripts are not allowed. This image is an example of a student diagramming form generation within her parametric precedent. Source: (Author 2013)

2.6. Active learning classroom

The latest addition to the course, started in 2014, is a change from our traditional lectures to active learning sessions, facilitated by the introduction of the university's new active learning classroom (Figure 4). This new space features whiteboards, integrated laptops and monitors, and wireless microphones. Most importantly, instead of a lecture hall, with seats facing a podium, the space is filled with small group tables where the students face each other. The instructor gives brief, 5-10 minute lectures as a follow-up from the labs and videos earlier in the week. These talks are used to set up small group and class activities and discussions. For example, students might be asked to summarize concepts from a lecture on the whiteboard, diagram a script using touchscreens, or debate computational issues with the microphones. Similar to the active labs, the instructor walks around the room, encouraging discussions and clarifying points. A typical class period features several activities, which help the students reflect upon and develop their understanding of the week's topics.

We are still collecting data from this latest change to the course, but preliminary results suggest that students find the active classroom helps them understand computation better. At a minimum, the active learning discussions do not seem to have harmed student performance. We will report our findings shortly.



Figure 4: A group activity taught using the technology and specially-designed spaces of our active learning classroom. Source: (Author 2014)

In the next section, we will discuss how introducing active learning affected student performance and attitudes about *Computational Methods*.

3.0 METHODOLOGY AND ASSESSMENT

When *Computational Methods* first launched, we had no frame of reference for it within the curriculum and, therefore, no sense of how to measure its success. However, now that we have three years of data, we can identify trends and useful metrics². If we compare these numbers from year to year, there is evidence that the active learning methods have helped *Computational Methods* perform better as an introductory course.

Table 1: Student Performance in Computational Methods. Traditional format in 2011; active learning format 2012-2014.

Year	# of students	Average score (%)	% Passing (students)
2011	71	83.1	87.5
2012	75	87.2	95
2013	74	88.5	97
2014	56	88.4	100

Our most critical metric is the pass/fail rate of the course. Because the course is required, we want to be sure our students keep up with the class and learn the material. In this sense, incorporating active learning appears to be an improvement. (Table 1) lists the pass rate of the course each semester, which we define as a C or better for both undergraduates and graduates. In the first iteration of the course, with traditional lectures and labs, the pass rate average between graduates and undergraduates was 87.5%. After updating the course pedagogy, the pass rate improved to 95% in 2012 and 97% in 2013. As of the last class (2014), the pass rate was 100%. Over this period, the course size has remained constant within statistical margins. By changing our teaching methods, without significantly altering the objectives or overall content of the course, more of our students pass the course than before³.

In addition to examining objective course performance through assignments and testing, we developed a survey instrument to track student attitudes and impressions about the course. The surveys are online, voluntary, and anonymous and consist of basic demographic questions, a series of Likert-scale inventories, and short answer essays to account for answers outside the scope of the survey. Each year, we issue a pre-class and post-class survey, which we use to measure changes in our students over the semester. Our response rates are typically high, averaging close to 75% over the past three years.

The surveys have helped us measure our students' level of engagement. In other words: do they find the material relevant to their education and do they feel value in what we ask them to do? Positive affect is essential to promoting deep learning that transfers to other contexts (Pugh and Bergin 2006). If students do not think a course is worthwhile, they tend not to perform as well (Lepper 1985). In terms of affect, we found that the 2012 revisions made a difference. The most significant change in attitudes came in response to the post-class survey statement, "I think *Computational Methods* should be a required course." In 2011, only 36% of the class agreed. In fact, 26% strongly disagreed with the statement. The new instructional methods appear to have inverted this result. An average of the past two years' results revealed that 80% of our students now agree the course should be required and, of this cohort, 25% strongly agree. Students in the new version of *Computational Methods* not only believe the course is relevant, but they also report greater satisfaction from their participation in the course. In response to the statement "I am satisfied with my experience," 64.7% of Fall 2011 students agreed. This number improved to 94.2% and 98% in Fall 2012 and 2013, respectively. These evaluations are encouraging by themselves, but even more encouraging is the fact that they have remained consistent for the past two years. This suggests that they are the likely result of our new pedagogy and not a one-time occurrence.

4.0 REFLECTION AND FUTURE WORK

As of this writing, our assessment of *Computational Methods* is moving into a new phase. We are now conducting an in-depth analysis of past assignments to determine common misunderstandings and continuing to examine the impact of the course upon the rest of our curriculum through follow-up surveys. However, many questions are beyond the scope of our current studies. For instance, because we made a number of changes to the course between the first and second set of iterations, we cannot determine which of these interventions (or which combinations) resulted in improved student performance. A more controlled study could help clarify our findings. Another important question is how to more accurately measure computational thinking. We currently assess students' conceptual knowledge and success at specific tasks, but this may present an incomplete picture of their understanding. For instance, a student might provide the

correct answer to a question, but their process or reasoning may be flawed. In future research, we hope to improve our assessment techniques by observing how students apply computational thinking in problem-solving situations.

CONCLUSION

Introducing active learning into *Computational Methods* appears to be an improvement over traditional tutorial- and design-based pedagogies. Using empirically-proven teaching methods from other fields, we have improved how we teach computational design to a large audience with diverse backgrounds and aptitudes. Our students can competently apply computational skills and report a strong feeling of satisfaction with their efforts.

If a computationally literate profession is the goal, architectural education must change the way it teaches computing. *Computational Methods* proposes that a more learner-centered strategy can help architects learn the material better, but the pedagogy is still evolving and many key questions remain. We hope that by sharing our development process and results, our experiences may serve as a model for instructors and researchers to follow and improve.

REFERENCES

- Bonwell, C. C., & Eison, J. A. 1991. Active Learning: Creating Excitement in the Classroom. 1991 ASHE-ERIC Higher Education Reports: ERIC Clearinghouse on Higher Education.
- Bransford, J. D., Brown, A. L., & Cocking, R. R. 2000. How People Learn: Brain, Mind, Experience, and School. Washington, DC: National Academies Press.
- Burry, M. 2011. Scripting Cultures: Architectural design and programming. New York: John Wiley & Sons.
- Collins, A., Brown, J. S., & Holum, A. 1991. Cognitive Apprenticeship: making thinking visible. *American educator*, 15(3), 6-11.
- Crouch, C. H., & Mazur, E. 2001. Peer instruction: Ten years of experience and results. *American Journal of Physics*, 69(9), 970-977.
- Dalbey, J. and M. C. Linn. 1985. The Demands and Requirements of Computer Programming: a literature review. *Journal of Educational Computing Research*, 1(3): 253-274. Amityville, NY: Baywood Pub. Co.
- Dempster, F. N., & Farris, R. 1990. The spacing effect: Research and practice. *Journal of Research & Development in Education*.
- Lepper, M. R. 1985. Microcomputers in education: Motivational and social issues. *American Psychologist* 40(1): 1-18. Washington: American Psychological Association.
- Kay, A. 1993. The Early History of Smalltalk. *ACM SIGPLAN Notices* 28(3): 69-95. New York: Association for Computing Machinery.
- McDowell, C., Werner, L., Bullock, H., & Fernald, J. 2002. The effects of pair-programming on performance in an introductory programming course. In *ACM SIGCSE Bulletin* 34(1): 38-42. New York: Association for Computing Machinery.
- Nagappan, N., L. Williams, et al. 2003. Improving the CS1 experience with pair programming. In *SIGCSE Bulletin*, 35(1), 359-362. New York: Association for Computing Machinery.
- Paas, F., Renkl, A., & Sweller, J. 2003. Cognitive load theory and instructional design: Recent developments. *Educational Psychologist*, 38(1), 1-4.
- Prince, M. 2004. Does active learning work? A review of the research. In *Journal of Engineering Education*, 93(3), 223-231.
- Pugh, K. J., & Bergin, D. A. 2006. Motivational influences on transfer. *Educational Psychologist*, 41(3), 147-160. Washington: American Psychological Association.
- Tucker, B. (2012). The Flipped Classroom. *Education Next*, 12(1), 82-83.
- Senske, N. (2011). A Curriculum for Integrating Computational Thinking. In *Parametricism: ACADIA Regional Conference Proceedings*. Lincoln, NE., 91-98.
- Senske, N. 2014. Confronting the Challenges of Computational Design Instruction. In *Proceedings of the 19th International Conference of the Association of Computer- Aided Architectural Design Research in Asia - CAADRIA 2014*, Kyoto, Japan, 831-842.
- Wing, J. M. 2006. Computational Thinking. In *Communications of the ACM*, 49(3): 33-36. New York: Association for Computing Machinery.
- Winslow, L. E. 1996. Programming pedagogy—a psychological overview. *ACM SIGCSE Bulletin*, 28(3): 17-22. New York: Association for Computing Machinery.

Collaborative solid wood construction case study

Erin Carraher¹, Jörg Rügemeier¹

¹University of Utah, Salt Lake City, UT

ABSTRACT: This paper describes the design, development and construction of three 600ft² summer cabins completed in July 2014 by faculty in the University of Utah College of Architecture + Planning's Integrated Technology in Architecture Center (ITAC) for the Girl Scouts of Utah's Trefoil Ranch Camp near Provo, Utah. This multifaceted project integrated material and off-site fabrication research, community design services, outreach and education to an underserved population, and provided applied learning opportunities for architecture students.

The organizing team took an integrated, multidisciplinary design and development approach in which stakeholders, architecture faculty, general contractor and fabricator, engineers, the building department, Girl Scouts, and architecture students were involved. The predominantly utilized building material was Interlocking Cross-Laminated Timber (ICLT), which is a panelized wooden construction material relatively new to the US construction marketplace. This paper reports on the participatory, interdisciplinary development process of the project.

KEYWORDS: Collaborative Design, Women in Architecture, Sustainable Design, Architecture and Education, Interlocking Cross-Laminated Timber

INTRODUCTION

Project: ARCHITECTURE is a new partnership between the Girl Scouts of Utah (GSU) and the School of Architecture (SoA) at the University of Utah, to raise awareness of careers in the built environment for women and to provide opportunities for architecture students to actively engage in service and creative projects. The inaugural project for this partnership was the design and construction of three cabins for the Girl Scout's Trefoil Ranch Camp near Provo, Utah.

As an important part of the participatory design process, the authors hosted a yearlong series of outreach events to expose Girl Scouts directly to women practitioners, to provide female student mentors in design-related programs, and to offer opportunities to visit architecture firms and construction sites, as well as providing the girls a first opportunity to engage with an institution of higher education.

1.0 DESIGN DEVELOPMENT

1.1. Context

The Trefoil Ranch Camp is located on a wooded site at the upper end of Provo Canyon at an elevation of 6,040', which is within the Utah Cold Climate Zone. Due to the warm, dry summers and cold winters with a heavy annual snow load, the camp's use is restricted to the summer months only when it offers diverse activities during daily, weekend, or weekly camps to the GSU population, which ranges in age from 5 years to 18 years. Thus the cabins are not heated for the winter months, and their utilities are reduced to electricity only with bathhouses, a common kitchen and activity areas, bunkhouse, and meeting and gathering places in the main lodge and existing facilities providing additional services.

1.2. Building material

Interlocking Cross-Laminated Timber (ICLT) was the primary building and construction material used for the cabins. Originally developed in Europe, Cross-Laminated Timber (CLT) uses adhesives or mechanical fasteners to assemble solid softwood timber stock into structurally sound, cross-laminated building components and panels. ICLT is a similar, prefabricated cross-laminated solid softwood wall, floor, or roof panel that is fabricated from two to seven layers of alternating direction pine stock milled from waste or beetle-killed pine wood using a robust, CNC-controlled process. Binding the CO₂ content of already dead wood into this long lasting, low maintenance product, ICLT has a low environmental impact over the project's life-cycle and eliminates the use of VOCs by removing adhesives from the assembly. The cabins were built in collaboration with industry partner Euclid Timber Frame PC, a company focusing on natural building methods using no glues, binders, adhesives, or products with VOCs. Euclid Timber with research support from the University of Utah's Integrated Technology in Architecture Center (ITAC) has developed ICLT as an

innovative and highly-sustainable material to incorporate locally-sourced wood damaged by pine beetle infestation prevalent in the American West.

Simple dovetail joints connect the pine stock elements, utilizing no fasteners and no adhesives within each panel. This system reduces overall capital cost typically incurred by either stainless fastener purchase and install or press purchase and set up associated with glue lamination [Smith 2010, 2011]. Mechanical fasteners were used for the assemblage of the panels on site, which means that capital cost can be reduced by increasing the size of each components to the point where size is limited by the access to the construction site, availability of equipment, and transportation restrictions. In case of the GSU summer cabins, the assembly method of choice for certain components was adjusted during the design process and through collaboration with the structural engineers. Due to dead, live, and snow load requirements, the thicker horizontal floor and sloped roof panels were assembled in Brettstapel construction, in which softwood timber boards are connected in parallel with hardwood dowels. After pressing those into place, the dowels absorb the moisture of the soft wood and swell, thus creating a very strong, force-fit connection [Greve 2014].

One of the major advantages of utilization of ICLT and Brettstapel was its time-savings potential: the building components were pre-manufactured in the contractor's controlled environment, utilizing a construction sequence that involved a highly-detailed computer model from which the solid wood wall components were then milled on a CNC router. The individual pieces were joined together in 'chunks' in the shop to form manageable modules that were delivered to the site where they were assembled and fastened together. In parallel, the site and foundation work was prepared and finished to allow for relatively short assembly phases on site. Thus construction time and costs were reduced, and a higher level of quality was maintained. Transportation cost and impact onto the site were also minimized, with the third cabin being erected in just a few weeks.



Figure 1: ICLT and Brettstapel Component and Panel Assembly. (Authors 2013)

The ICLT system presents a new approach in construction technology, material process, and assembly methodologies. Binding the CO₂ content of already dead wood into this long lasting, low to no maintenance highly sustainable wood product, the panels have a low environmental impact over the project's entire life-cycle, including a high ratio of renewable energy to fossil energy in construction through very low embodied energy in the material. The cabins provide long-lasting, healthy, and useful buildings that conserve finite resources and fossil energy by using this extremely durable, recyclable, and renewable natural material. Utilization of this material puts the project at the forefront of sustainable construction with findings expected to influence the construction market along the Wasatch Front and beyond.

1.3. Design Philosophy

The regionally rooted typology adopted for the cabins is simple, clearly defining the project as highly sustainable from a design as well as a material standpoint. It echoes the regional, functional design of old farm buildings in the canyon as well as the typology of the camp's old wooden tent platforms, which were originally erected on simple CMU piers. The cast in place concrete piers for the new cabins were chosen to minimize construction disturbances while simultaneously maximizing land use efficiency. Clad in mild steel that changes color over time, the cabins already blend well into the site. In addition, the steel has been chosen for its fire resistance properties, allowing for the reduction of wall thicknesses to the structural minimum for material efficiency with the metal cladding providing the code-required fire protection.



Figure 2: Completed Cabins. (Nicholas Steffens 2014)

Each cabin has an inviting, shaded patio that is oriented towards the common gathering, activity, and fire pit area with the cabin to the north also offering additional outdoor seating on its stairs directly adjacent to this outdoor hearth. Access to the cabins is through this communal space, supporting the idea of community and communication among the campers. On the inside, the cabins offer a spacious, day lit, warm, and healthy interior that provides accommodation for up to 10 scouts each. To allow for indoor activities, the bunk beds of each cabin are grouped around large tables, which were designed and digitally manufactured by students at the SoA. A small changing room completes the spatial arrangement. The tall entry door and vertical egress window oppose each other on the short cabin elevation, allowing for a direct visual connection into the woods upon entrance. The four bay windows on the long sides echo the verticality of the trees and offer a small seating bench in each bay; the arrangement of the upper, operable windows allow for cross ventilation. Similar bays without windows, one on each side of the porch, offer views when outside.

The design maximizes the use of on site natural resources, such as sun exposure, wind protection, orientation, and preserves environmental quality with the goal to support the local ecosystem through design with nature. The cabins respond to a socially viable environment and reflect the value of the local community. They provide an outstanding case study for the scouts, raising critical awareness of finite resources and a sensible use and management of an important natural resource. Within its larger context of the GSU, the project creates a space of communal significance and social value.

The collective, integrated design and construction process applied by the team consistently included all stakeholders, building authorities, students, scouts, contractors, and trades. Through the efficiency of the design and the chosen materials, the cabins provide a long-term economic benefit for the users and GSU as a non-profit organization. During construction the team also focused on fulfilling highest ethical standards for

the construction crew, and ensured through continuous visits at the site and the manufacturing plant the high quality of working and product conditions.

For the design development, in which many of the schematic decisions were further explored and finalized, groups of students and Girl Scouts were involved in the decision making process to ensure a functional architecture that would not only be rooted in the local context but would also become the most functional solution for its occupants. During design meetings, number and shape of the beds were discussed and defined, moving from space-consuming single beds to more efficient bunk-beds, which also allowed the team to stay within the given construction budget by reducing the overall cabin size by approximately 25% and introducing a common space for in-cabin activities. The importance of a porch for each cabin was discussed, and the desire for a large table in the center of the cabin emerged. After consultation with stakeholders and the client, all of those measures were successfully implemented into the scope and design of the project.

1.4. Participatory Design Process

Integrated throughout the participatory design process of the cabin project have been outreach activities benefiting both SoA students and the Girl Scouts. Utah's population of female practitioners is well below the national average (women practitioners currently account for only 14% of the population), so recruitment was a primary goal of the project in addition to helping raise the awareness of high quality design in the community. The SoA also has a disproportionately low percentage of female students, so the opportunity for the program to have a significant impact on the local, regional, and state community is high.



Figure 3: Completed cabin interiors with student-designed tables. (Authors 2014)

The GSU involvement in the project was two-fold: there was a Leadership Group of middle- and high-school aged scouts who followed the project through all stages by participating in workshops, site visits, design charrettes, and firm tours, and a broader audience of scouts of all ages who participated in an event in April 2013 that used projects specific to the cabin design to demonstrate general principles about architecture, urban planning, landscape architecture, and multi-disciplinary design. In more detail, the participatory design and development process included participation of SoA students at the Western Mountain Regional/Northwest Pacific Region (WMR/NWPR) Leadership Institute, hosting a booth at the 2012 Girl Fest, organizing a large kickoff event at the SoA, a design charrette, several site visits and tours of Euclid Timber for scouts and students, a consultation meeting for table designs, the design and digital manufacturing of the tables themselves, the day-long educational event for 75 scouts of all ages in April 2013, and a public groundbreaking party shortly after completion of the project. Additionally, SoA students were also involved in construction administration.

The authors believe the collaboration was mutually beneficial to both parties and has been successful in achieving its goals as evidenced by the final project outcome. Project: ARCHITECTURE, the first major project to be developed as a result of the partnership, has created opportunities for mentoring relationships at multiple scales amongst the scouts, architecture students, and female practitioners.

2.0 OUTREACH ACTIVITIES

2.1. August 2012, GirlFest

GirlFest is an annual event celebrating the Girl Scout Leadership Experience with activities for scouts to discover new skills and strengths, connect with other girls and their community, and take action to make their neighborhood, community, and the world a better place. School of Architecture students manned a booth at the event in August 2012 to educate girls K-12 about architecture in general and promote the upcoming Project: ARCHITECTURE activities. An activity at the booth where girls decorated laser cut wooden cabins allowed for the younger girls to engage while students shared their knowledge and discussed the program with troop leaders and parents. The event served as a recruitment tool for potential Leadership Group participants.

2.2. October 2012, WMR/NWPR

SoA students and their faculty mentor participated in the Leadership Institute, a two-day workshop conducted in advance of the AIA's Western Mountain Region/Northwest Pacific Region Joint Conference in Tucson, Arizona. Students arrived with proposals that they presented to the group of peers from architecture schools throughout the region. Over the course of two days, students participated in presentations, work sessions, and lectures intended to develop their leadership and advocacy skills and their community-engaged projects. The mission of the program is to provide emerging professionals the opportunity to learn leadership strategies from professionals, to develop leadership skill sets, to establish a forum that will facilitate dialog amongst future leaders, and to advance the next generation of professionals to critical roles in the design and construction of the built environment.

2.3. October 2012, Kickoff meeting

In October 2012, the Leadership Group of scouts met with representatives from the GSU, SoA student mentors, and the authors to discuss the project. The group also reviewed the proposed involvement of the Leadership Group intending to help them become invested in the project activities. Simultaneously, the Leadership Group was introduced to the basics of architectural design, sustainable use of resources and materials, and the educational as well as spatial environment of the architecture school through a series of interactive presentations and exercises. After touring the buildings facilities and talking to students working in the studios, they participated in a discussion about how to make buildings more sustainable and better performing. At the end of the day, they left with a high level of motivation and a suitcase full of impressions, ideas, and encouragement about their power to shape the cabin project going forward.

2.4. November 2012, Site and manufacturer's fabrication shop visit

The Leadership Group along with students and faculty of the SoA visited the site and the fabrication facility to gain a better understanding of the cabin context and to understand the process of designing and manufacturing the ICLT components for the structures. On the cabin site they were able to explore and understand the specific nature of the place, see the challenges of the undulating terrain, and visit the older cabins that had been built using standard construction the year before. The latter was an important lesson in better understanding how ICLT buildings are planned, manufactured, and assembled, which was the major focus when visiting Euclid Timber, the ICLT manufacturer, right after the site visit.

2.5. December 2012, Design charrette

After initial code review and space allocation exercises were conducted by the authors, the GSU, troop leaders, architecture students, and Project: ARCHITECTURE coordinators were invited to take part in a design charrette for the cabins. The scouts provided important input and design ideas that shaped the cabin direction. This was an invaluable experience for students as well in understanding the positive impact a client can have on a design.

2.6. April 2013, Capstone event

The capstone to the service and outreach component of the project was an event on April 20th, 2013 that involved approximately 75 scouts, including the Leadership Group. The event paired architecture students, a female practitioner, and a Leadership Group scout together to develop a series of activity sessions that exposed girls of all ages to the principles of architecture, design, and planning through hands-on activities. In addition, the day started with a panel discussion where female architect-practitioners - including the dean of the College of Architecture + Planning, a senior vice president at the University, the first female fellow of the American Institute of Architects in Utah, and the principle of the AIA Utah Architecture Firm of the Year - spoke about how they became interested in architecture and their experience in practice.

Each session was run by a practitioner and one or more of the SoA students who helped coordinate the various activities. The event ended with a 'big reveal' of the cabin design and discussion of how the design was developed to incorporate sustainable principles and input from the scouts. After the event, the Leadership Group was invited to tour a local architecture firm and have a discussion with senior and junior members of the office on what an architect does in practice.

2.7. September 2013 to May 2014, construction

Throughout the construction process, students and scouts were kept abreast of progress and invited to the site for tours at key points. This opportunity was highly valued especially by architecture students, as for most students it was their first exposure to seeing something they helped design under construction. Additionally, students from a variety of unrelated courses toured the site during construction and after completion in technology courses that used the cabins as case studies.

In all, the construction process was more complex for these simple cabins than it might have been for a more standard building, and the students were able to witness the process. They observed the challenges of the construction process with regard to code compliance: the jurisdiction changed fire marshals during construction, and the new marshal had a different interpretation of key aspects of the project. They were exposed to the process of utilizing a new material system (ICLT) in one of the first times in practice: the original intention for the piers was to minimally disturb the site, but due to the load of the solid wood panels and the structural engineer's caution in working with a new system, the oversized footings required significantly more excavation than originally intended. They were exposed to the process of public relations and fundraising: students observed the process of soliciting donations for materials and assemblies to help offset costs for the cabins. These and many other lessons were beneficial to students in their understanding of the day-to-day workings of construction administration.

2.8. July 30, 2014, Ribbon cutting

A ribbon cutting celebration took place on July 30, 2014 in which scouts, camp staff, GSU board members, parents, architecture students, contractors, vendors, and local politicians took part in celebrating the cabins' dedication. Speakers discussed the process of design and construction and scouts, students, and the authors led people on tours of the cabins, which had been in use since the beginning of the summer camp season. The celebration was also attended by several local and regional news outlets, which provided coverage of the cabins, featuring the scouts' involvement and the ICLT material utilization.

3.0 TRANSLATABLE FRAMEWORK

3.1. Strategic partnerships

The authors have found that one of the most difficult aspects to building strategic industry partners is the challenge of convincing these companies and organizations of the value of architects' ability to strategize, design, and research. It is important to be cautious of individuals and organizations seeking free design assistance under the guise of offering 'valuable experience' for students. Often times starting with a small research project to establish trust and demonstrate the benefit of student and/or faculty engagement or showing successful past projects is a strategic first step toward building a lasting collaborative relationship.

3.2. Student engagement

Student engagement is critical in creating rich collaborative partnerships such as Project: ARCHITECTURE. Not only do the students gain valuable experience in design and construction projects but they also get the opportunity to serve as teachers and mentors to younger children, reinforcing the value of their education and experience. Given this responsibility, students take ownership over the process and are advocates and assistants in realizing the best possible end result.

For this project, the authors chose not to conduct the design and research as part of a formal course for two reasons: the project was going to invariably last longer than one semester and continuity of the students across a two-year process wouldn't be feasible within the academic structure; and flexibility in structure let students phase in and out of the project based on needs and interest. Additionally, students were able to receive IDP credit for their time spent on the project.

In addition to the creative work and outreach components of the project, the authors have made every effort to leverage the partnership with the Girl Scouts for real-world design opportunities for architecture students. For example, faculty taught a graduate seminar in the spring of 2013 on digital fabrication where students designed and built tables that the scouts indicated were desirable for communal activities in the cabins. The GSU served as the 'client' for the tables, and students involved in the cabin project who were not part of the course participated in critiques.

3.3. Faculty research

Oftentimes faculty research is disconnected from service and teaching activities. By layering several components to the project and seeking out potential connections (the graduate seminar in digital fabrication using the tables as a project for example), the authors were able to devote the time needed to achieve this undertaking without sacrificing other work or creating an overload. Administrative support is critical to the success of such an undertaking as well as faculty buy in to the value of community-engaged practices as research. For example, the contract developed for the project was the first of its kind at the university and required extensive work from the college and university legal departments, and administrative assistance was needed in advocating for an exemption to the university policy of charging approximately 50% overhead on research money. By demonstrating the positive experience for students and benefit for the non-profit GSU, the funding was accepted as a grant but under a service designation with 0% overhead.

3.4. Education and outreach

Like many architecture programs, the authors' institution is constantly seeking ways to elevate the dialog about good design in the broader community, develop relationships with potential applicants, and create more meaningful connections with the practicing community. Through anecdotal accounts and more formal metrics, the project has been incredibly successful at achieving the immediate goals. Time will tell if engaging with the Leadership Group of middle- and high-school students will lead to an increase in applications from these scouts who self-identified as being interested in architecture. Additionally, the social and religious context of Utah has historically led to a far more male-dominated education and practicing community than the national averages. By focusing this project on outreach and education to women (though not excluding men), the project has the additional advantage of serving an underrepresented population of current and future architecture students.

3.5. Observations and next steps

Much was learned from the project on the logistics side. Future projects will be structured based on both custom contracts as well as standard AIA owner-architect and owner-contractor agreements. The methods of engagement with students and professionals were highly effective, but retention of Leadership Group scouts over the year-long sequence of events waned. Feedback and discussions with these girls has led to the idea of developing an "Architecture Badge" as a tangible goal that the scouts can work toward with a discrete number of activities to commit to in advance. Following up with the scouts is critical over the next several years, and the offer has been made to sponsor future capstone Gold projects (the equivalent to Boy Scouts' Eagle Scout distinction). Building off of the success of the cabin project, the authors are working with the GSU on a vision plan for the GSU's other Utah camp, which consists of 350 acres of pristine mountain landscape outside Park City, Utah, a best practices guide for the national organization on such partnerships, as well as a variety of other building and planning projects at multiple scales.

CONCLUSION

Beginning even before the completion of construction, the project received 5 important design, collaboration, and diversity achievement awards, and was extensively covered in the regional media. During a national convention for the Girl Scouts of America held in Salt Lake City, the authors toured property managers from all over the country around the cabins and discussed the collaborative process that led to their development. The authors are confident in stating that the project overall has been a tremendous success in its goal to serve as an outreach, teaching, and research initiative that links faculty and students in architecture, Girl Scouts of Utah, and female practitioners with industry to create learning opportunities about architecture through sustainable building design and construction projects.

The authors also believe that the project has had a significant impact on the community, which includes the general public in the form of GSU, parents, and troop leaders; the academic community of students and faculty who volunteered for the project; and the professional community who engaged in mentoring the GSU and architecture students by sharing their expertise. This impact includes both a sustainable focus as it relates to the ICLT material utilized for the cabin design as well as a social focus as it relates to current and future female architects.

ACKNOWLEDGEMENTS

Client: Girl Scouts of Utah: Lisa Hardin-Reynolds, Amber Kuecker, Scott Blackburn, Carly Cahoon
Architects: Jörg Rügemer, Erin Carraher
Table & Chair Collaborator: Bradeson Brinton
ICLT Developer/Fabricator/Contractor: Euclid Timber Frames L.C.: Kip Apostol, Mark Nelson
ICLT Research: Ryan E. Smith
Steel Fabrication: Wasatch Steel, Kingdon Sheet Metal
Special Thanks: Brenda Scheer, Prescott Muir, Keith Bartholomew, Ryan E. Smith, Bob Mutz, Mayra Focht, Roger Thom, Robbi Richter, Julie McAdams, Robert Payne, Mark Haslam, Libby Haslam, Mark Green, Teresa Wu, Darrick Despain, Jared Colton

Program Volunteers: Celestia Carson, Charlotte Frehner, Elpitha Tsoutsounakis, Shalae Larsen, Shundana Yusaf, Anne Mooney, Brenda Scheer, Jeanne Jackson, Heather Wilson, Benjamin Baird, Whitney Ward, Bradeson Brinton

REFERENCES

- Greve, Nina. 2014. "Gut im Brett! Passivhäuser in Massivholzbauweise." *Passivhaus Kompendium 2015*: 83-85
- Smith, Ryan. 2010. *Prefab Architecture: a guide to modular design and construction*. 128-131. Hoboken: John Wiley and Sons, Inc.
- Smith, Ryan E. 2011. *Making the Most of the Beetles*. University of Utah Redthread (online): <http://redthread.utah.edu/making-the-most-of-the-beetles-%E2%80%93-an-alternative-use-of-standing-dead-forest-wood/6184>

Comparative analysis of architectural education standards across the world

Suchismita Bhattacharjee¹, Shivashish Bose²

¹University of Oklahoma, Norman, OK

²Jadavpur University, Kolkata, India

ABSTRACT: A study performed by International Union of Architects showed that 78 countries across the world have their architectural education standards regulated by an authority (often governmental) (COAC 2005). Considering the fact that architects often practice in countries they have not received their education from, it is necessary that a standard architectural education curriculum be developed across the world. To do so, it is very important to compare the education standards across all the countries and develop a baseline understanding.

This paper provides a comparison among the architectural educational standards across the world. Information regarding the regulatory bodies monitoring the educational system was gathered from the study performed by International Union of Architects in 2005 (UIA, 2014). Further, the architectural education standards of the different governing regulatory bodies were obtained from their respective websites. The study looked into the architectural education requirements of all the 78 countries.

While results indicated that core requirements for architectural education showed high variation across countries, the areas of emphasis of the core requirements could be broadly categorized as design theory, technical systems, design documentation, and professional practice.

KEYWORDS: Architectural Education, Education Standards, International Union of Architects

INTRODUCTION

As defined by International Union of Architects, an architect is “a person who is professionally and academically qualified and generally registered/licensed/certified to practice architecture in the jurisdiction in which he or she practices and is responsible for advocating the fair and sustainable development, welfare, and the cultural expression of society’s habitat in terms of space, forms, and historical context”.

In the context of today’s global change, architects are no longer confined to the borders of their own countries when providing services. With the rise of open economies in Eastern Europe, India, and China the international borders have been broken and international practice is becoming a norm for the architects. Architects are found creating master pieces around the world either practicing from their home country and collaborating with foreign fellow architects or sometimes opening offices abroad. Several examples of famous architectural master pieces around the world have been designed by architects from another nation such as Burj Khalifa in Dubai designed by American architectural and engineering firm Skidmore, Owings and Merrill LLP; Guggenheim Museum in Bilbao designed by Canadian-American architect Frank Gehry; etc. Considering the fact that architects practice in countries they have not received education from, it is necessary that a standard architectural education curriculum be developed across the world. To do so, it is very important to compare the education standards across all the countries and develop a baseline understanding of the different education systems.

To take an initial step in that direction, the authors attempted to conduct a comparative analysis of the architectural education standard of the different nations across the world.

1.0 BACKGROUND & PROBLEM STATEMENT

1.1. What is Architecture?

Architecture is a collective process of planning, designing and constructing structure or buildings. As defined by Steven Holl, the principal architect for Steven Holl Architects

“While artists work from the real to the abstract, architects must work from the abstract to the real. While art may legitimize itself as an object or an event, architecture dissolves into a blur of buildings. Architecture, under all of its constraints of engineering safety, function, climate responsibility and economy, sometimes transcends to inspire us with ideas in space and light—qualities achieved in the abstract”(Cruz 2013).

George Hersey broadened the scope of architecture profession even further through his definition when he included on only what 'we' built, but also much else besides –anthills, beehives, various body parts and some molecules (Hersey 2001).

1.2. Origin of the Profession

Architecture has not always been the same profession as it is today. In industrial world that we live in today every object is design by someone specially trained to do just that. Thus the name of architecture as a profession gained its identity as professionals who are experts in planning, designing, and constructing buildings or structures. As mentioned by Lawson in his book 'How designers think', vernacular process of designing is very closely associated with the concept of just making (Lawson 2006). He further explains the statement with the example of Eskimos who do not require an architect to build his igloo. The development in civilization and the need for more complex structures warranted the need for individual who are experts in the field, thus giving a separate status and identity to the profession of architecture. As early as in 1791 there was an 'Architects Club' in United Kingdom and later several other Architectural Societies were established. By 1834 the Institute of British Architects was founded which was no longer just a club or a society but rather an organization of like-minded people with an aspiration to raise, control and unify standards of practice.

The process of professionalism eventually led to a situation where the need for legally protecting the body of architects became inevitable. This body of professionals also started gaining more respect and eventually became socially respected exclusive elite (Lawson 2006). Thus it led to a need for higher standard of education to protect the profession.

1.3. History of Architectural Education

Architectural education that we are aware of today is a relatively recent phenomenon. Since historic times architectural education has relied on the process of transmission of knowledge and information from the masters to pupils. In the early nineteenth century, the French added a new outlook in the field of architectural education with the formation of schools to train architects, the École des Beaux Arts (Stevens 2001). Throughout the next century the field of architectural education slowly got embedded in the higher education systems. The history of architectural education can be mapped as a progressive movement of knowledge transfer from the workplace into the College or University studios. This movement has been interpreted as a series of political conspiracies in a study performed to interpret the history of architectural education with the Prince of Wales Institute of Architecture (Crimson and Lubbock 1994).

Over the years the architectural education system evolved with four distinctly different but overlapping systems. The French introduced the concept of organized formal architectural education system, followed by Germans who introduced the concept of research in the field of architectural teaching, and United States took the lead to synthesis the two in a University setting with an overlaying concept of apprenticeship (popularly known as internship) inherited from United Kingdom (Weatherhead 1941). This prompted the need for more structured architectural education standards across the world.

2.0. RESEARCH GOAL, OBJECTIVES & METHOD

In an attempt to have a better understanding of the architectural education systems across the world, this study aims to perform a comparative analysis of the education standards of 78 countries. This is a qualitative study adopting the method of content analysis of the education standard information of 78 countries as available on their respective websites.

2.1 Data Source

The strategy used for this systematic review was an extensive search of the websites of different governing regulatory bodies of architectural education in the different countries around the globe. Further the publications and databases of organizations focusing on architectural education systems across the world such as 'International Union of Architects', 'Royal Institute of British Architects' etc. were reviewed. Several published articles on architectural education were also reviewed through databases such as 'Avery', 'Academic Search Premier', 'Google Scholar' etc. The key words entered for this search were 'architectural education', 'architecture education and practice', 'architecture curriculum', and 'design education'. In this process various design and educational journals (e.g., Design Studies, Journal of Architectural Education, Architectural Record etc.) were consulted. Further, reference lists of the articles were reviewed to locate additional published materials. This process was repeated till saturation.

2.2 Data Extraction

Using the method of content analysis quantitative data on several variables like number of architects, number of architecture students, duration of architectural education, requirement of and duration of internship, requirement for registration to practice, and the requirement of professional examination for

registration were extracted. Content analysis was also used to collect data on type of educational standards, type of courses, and focus areas of the education system from the websites of the governing organizations of different countries.

2.3 Data Synthesis

Data was synthesized to compare the architectural education standards of different countries across the globe. The template used for this synthesis was based on Guidelines for Critical Review Form for - Qualitative studies developed by the McMaster University Occupational Therapy Evidence-Based Practice Research Group (Law et al. 1998) .

3.0 FINDINGS & DISCUSSION

Architectural education system assists to maintain a certain standard of knowledge and design ability among the architectural students and the graduates. It includes familiarity with the technical systems, consideration of health, safety, ecological balance, and the cultural, intellectual, historical, social, economic, and environmental context for architecture.

3.1 Architectural Education Statistics

Architecture is taught as part of University education in 127 countries around the world. United States has the maximum number of Universities with architectural programs, followed by United Kingdom, Japan, Germany, Brazil, India, China, South Korea, and many more as represented in Appendix 1 & 2 combined. This finding is totally in contrast to the number of architecture students registered in each of the countries who responded to the survey conducted by Col·legi d'Arquitectes de Catalunya (COAC 2005). Japan has the highest number of students enrolled in architecture program followed by Germany, United States, China, Korea, Nigeria, Portugal and others. Japan also has the highest number of registered architects followed by Italy, United States, Germany, China, and United Kingdom.

3.2 Education Standards

According to a survey conducted by Col·legi d'Arquitectes de Catalunya(COAC 2005) 78 countries out of the 91 countries who responded to the survey, have regulating authorities maintaining architectural education standards in comparison to 2 countries who have architectural education system but no regulating organization monitoring the standards and 6 other countries who do not have any formal architectural education system. Appendix 1 provides information on the architectural education system of the 80 countries who responded to majority of the information requested in the survey.

Majority of the 78 countries have one central organization regulating the education standard as compared to countries like United States, United Kingdom, India, Japan, Pakistan, Philippines, Singapore, Thailand, Belgium, Denmark, France, Germany, Italy, Canada, Brazil, and New Zealand. For most of the above mentioned countries with more than one governing body, the responsibility of the organizations are well laid out, where if one organization is focusing on the education system, then other organization is geared towards the policies and practices of the profession. Table 1 below provides a list of the regulating organization of several countries.

Table 1: List of professional organization.

Country	Name of Organization	
Ethiopia	Association of Ethiopian Architects	
Kenya	Architectural Association of Kenya	
Nigeria	Nigerian Institute of Architects	
Senegal	Order of Architects of Senegal	
South Africa	South African Institute of Architects	
Zambia	Zambia Institute of Architects	
Zimbabwe	Institute of Architects of Zimbabwe	
Bangladesh	Institute of Architects Bangladesh	
Hong Kong	Hong Kong Institute of Architects	
India	Indian Institute of Architects	Council of Architecture
Indonesia	Ikatan Arsitek Indonesia	
Japan	Japan Federation of Architects Associations Japan Association of Architectural Firms	Architectural Institute of Japan Japan Institute of Architects
Malaysia	Board of Architects Malaysia	
Pakistan	Pakistan Council of Architects and Town Planners	Institute of Architects Pakistan
Philippines	Philippine Institute of Architects	United Architects of the Philippines
Singapore	Singapore Institute of Architects	Board of Architects Singapore
Sri Lanka	Sri Lanka Institute of Architects	
Thailand	Association of Siamese Architects	Architect Council of Thailand
Austria	Bundeskammer der Architekten und Ingenieurkonsulenten	
Belgium	Fédération Royale des Sociétés d'Architectes de Belgique Conseil National de l'Ordre des Architectes	Nationaal Architecten Verbond
Bulgaria	The Chamber of Architects	Union of Architects in Bulgaria

Croatia	Hrvatska Komora Arhitekata i Inženjera u Graditeljstvu	Udruženje Hrvatskih Arhitekata
Cyprus	Cyprus Architects Association	
Czech Republic	Ceská Komora Architektu	
Denmark	Architects' Association of Denmark (Akademisk arkitektforening)	Praktiserende Arkitekters Ansatte Arkitekters Rad
Estonia	Eesti Arhitektide Liit	
Finland	Suomen Arkkitehtiliitto SAFA	
France	Conseil National de l'Ordre des Architectes	Syndicat de l'Architecture
Germany	Vereinigung Freischaffender Architekten Deutschlands	Bund Deutscher Architekten
Greece	Association of Greek Architects	Technical Chamber of Greece
Hungary	Magyar Építészek Szövetsége	
Ireland	The Royal Institute of the Architects of Ireland	
Iceland	Arkitektafélag Islands	
Italy	ALA Assoarchitetti - Associazione Liberi Architetti	Consiglio Nazionale degli Architetti
Latvia	Latvian Union of Architects	
Liechtenstein	Liechtensteinische Ingenieur-und Architektenvereinigung	
Lithuania	Lietuvos Architektu Sajunga	
Luxembourg	Ordre des Architectes et des Ingénieurs-Conseils de Luxembourg	
Macedonia	Chamber of licensed architects and engineers of Macedoni	Association of Architects of Macedonia
Malta	Kamra Tal – Periti	
Norway	Norske Arkitekters Landforbund	
Poland	Stowarzyszenie Architektów Polskich	
Portugal	Ordem dos Arquitectos	
Romania	Ordinul Arhitecților din România	
Slovakia	Slovenská Komora Architectov	
Slovenia	Inženirska Zbornica Slovenije	
Spain	Consejo Superior de los Colegios de Arquitectos de España	
Sweden	Svenska Arkitekters Riksförbund	
Netherlands	Bond van Nederlandse Architecten	
Turkey	Chamber of Architects of Turkey	
UK	Royal Institute of British Architects	
Canada	Royal Architectural Institute of Canada	
US	National Architectural Accrediting Board	American Institute of Architects
Brazil	CAU - Architecture and Urbanism Council	IAB - Brazilian Architects Institute-
Costa Rica	Colegio de Arquitectos de Costa Rica	
Australia	Australian Institute of Architects	
New Zealand	New Zealand Institute of Architects	

3.3 Duration of Education

Further the education standards of the 78 countries were reviewed to identify the differences in their approaches. The duration of education varied from three years to six years. Countries with three years of architecture education such as Zimbabwe, Serbia & Montenegro, Belgium, United Kingdom are always followed with an extra two years of Masters professional degree. Majority of the countries has a requirement of a minimum of five years. For countries like United States and Canada the year limits are variable and it is more regulated by the number of courses the students are required to complete. Complete information on the duration of education of the different countries across the world is available in Appendix 1.

3.4 Internship

The scope and availability of internship and its requirement and duration during the course of education varied greatly among the countries. 16 countries that included Turkey, Netherlands, Mexico, Macedonia, Greece, Georgia, France, Finland, Spain, Ecuador, Costa Rica, Belarus, Brazil, Bolivia, Benin, and Argentina do not have opportunity for Internship as compared to 7 countries such as Armenia, Czech Republic, Egypt, Lithuania, Singapore, Slovenia and South Africa, where internship is option but is not required as part of their architectural education. For countries where internship is required as part of the curriculum, the duration of the internship varies greatly (from a minimum of six months of internship required in India to five years required in Mali). Appendix 1 provides more detailed information about the architecture internship opportunity and requirement for all the 78 countries.

3.5 Education Structure

A review of the several architectural education standards revealed that course requirements vary greatly from art and design focus to more technical aspects as building science and survey. The section below discusses the education standards of different countries:

3.5.1 Royal Institute of British Architects

The architectural education standard requirement of Royal Institute of British Architects (RIBA) mandates anybody qualifying as an architect to have completed at least five years of University education and

completed a minimum of two years of practical experience. The typical route for qualification includes the completion of part 1 through part 3, where part 1 is the completion of three years of fulltime undergraduate degree and gaining a year of practical experience; part 2 is the completion of two years of fulltime B.Arch or M.Arch degree followed by a 24 months practical experience; and finally part 3 is the completion of examination in professional practice and management to become a registered architect.

Under the Directive 2005/36/EC of the European Parliament, on the recognition of professional qualifications as an architect from a Europe Union (EU) country, architects are able to register and practice in of the 26 member countries of the EU. The entire 26 EU member countries follows the same architectural education requirement as RIBA with slight variation in their minimum requirement of practical experience as shown in Table 2.

Table 2: Architectural registration requirement of european nations.

No.	Countries	Requirement	Registration Requirement
1	Austria	Degree & 3 years prof. experience	Registration in Home country
2	Belgium	Degree & 2 years prof. experience	Registration in Home country
3	Bulgaria	Degree	
4	Cyprus	Degree	Proof legal practice in Home country
5	Czech Republic	Degree & Exam	Registration in Home country
6	Denmark	A qualified Architect from any EU country.	
7	Estonia	Degree & Exam	Registration in Home country
8	Finland	Any foreign Architect	
9	France	Degree & registered under RIBA	
10	Germany	Degree & 2-3 years of prof. experience	Registration in Home country
11	Greece	Degree	Registration in Home country
12	Hungary	Degree & Exam	Registration in Home country
13	Ireland	Registered under Royal Institute Architecture of Ireland (RIAI)	
14	Italy	Degree & 3 years prof. experience	Registration in Home country
15	Latvia	Degree & prof. experience	
16	Lithuania	Degree	Registration in Home country
17	Luxembourg	Degree & 1 years prof. experience	Registration in Home country
18	Malta	Degree & prof. experience	Registration in Home country
19	Netherland	Anyone can practice, but to register degree from and EU country required	
20	Poland	Degree & prof. experience	Registration in Home country
21	Portugal	Degree & 2 years prof. experience	Registration in Home country
22	Romania	Degree & prof. experience	Registration in Home country
23	Slovakia	Degree & 5 years prof. experience & Exam	
24	Slovenia	Foreign architects not allowed to practice	
25	Spain	Registered in any EU countries	Registration in Home country
26	Sweden	Registration not required (not regulated by law)	

3.5.2 National Architectural Accrediting Board

National Architectural Accrediting Board (NAAB) is the organization responsible for the development of standards of architectural education in the United States and procedures to verify that each accredited architectural program meets the set standards. The quote below from 1940 Founding Agreement of NAAB provides a brief description about the goal of the organization from its origin.

“The.... societies creating this accrediting board, here record their intent not to create conditions, nor to have conditions created, that will tend towards standardization of educational philosophies and practices, but rather to create and maintain conditions that will encourage the development of practices suited to the condition which are special to the individual school. The accrediting board must be guided by this intent. (NAAB 2014)”

According to the standards set forth by NAAB each graduates from an accredited program are required to possess knowledge and skill in certain predefined areas listed below in Table 3.

Table 3: Required knowledge and skill of graduates from NAAB accredited programs.

Realm	Skills required
Realm A: Critical Thinking and Representation	A.1 Professional Communication Skills
	A.2 Design Thinking Skills

	A.3 Investigate Skills
	A.4 Architectural Design Skills
	A.5 Ordering Systems
	A.6 Use of Precedents
	A.7 History and Global Culture
	A.8 Cultural Diversity and Social Equity
Realm B: Building Practices, Technical Skills, and Knowledge	B.1 Pre-Design
	B.2 Site Design
	B.3 Codes and Regulations
	B.4 Technical Documentation
	B.5 Structural Systems
	B.6 Environmental Systems
	B.7 Building Envelope Systems and Assemblies
	B.8 Building Materials and Assemblies
	B.9 Building Service Systems
	B.10 Financial Considerations
Realm C: Integrated Architectural Solutions	C.1 Research
	C.2 Integrated Evaluations and Decision-Making Design Process
	C.3 Integrative Design
Realm D: Professional Practice	D.1 Stakeholder Roles in Architecture
	D.2 Project Management
	D.3 Business Practices
	D.4 Legal Responsibilities
	D.5 Professional Conduct

3.5.2 The Royal Institute of the Architects of Ireland

Royal Institute of Architects of Ireland (RIAI) founded in 1839 is the regulatory and support body for architects in Ireland (Graby 1989). RIAI is responsible for regulating the education and practice of architectural profession in Ireland, besides maintaining the register of architects. RIAI has a set of 11 standards which describes the knowledge, skill and competence required for independent practice as an architect in Ireland. Indicator of each standards are described in the form of manageable and clearly defined requirements that are recognisably related to the realities of architectural practice. The indicators outline the specific areas in which a candidate is expected to demonstrate expertise, and the level of that expertise. Please refer to table 4 below for more information about the 11 standards.

Table 4: Architectural education standards by Royal Institute of the Architects of Ireland.

Reference	Standards
Article 46.1 (a)	Ability to create architectural designs that satisfy both aesthetic and technical requirements.
Article 46.1 (b)	Adequate knowledge of the history and theories of architecture and the related arts, technologies and human sciences.
Article 46.1 (c)	Knowledge of the fine arts as an influence on the quality of architectural design.
Article 46.1 (d)	Adequate knowledge of urban design, planning and the skills involved in the planning process.
Article 46.1 (e)	Understanding of the relationship between people and buildings, and between buildings and their environment, and of the need to relate buildings and the spaces between them to human needs and scale.
Article 46.1 (f)	Understanding of the profession of architecture and the role of the architect in society, in particular in preparing briefs that take account of social factors.
Article 46.1 (g)	Understanding of the methods of investigation and preparation of the brief for a design project.
Article 46.1 (h)	Understanding of the structural design, constructional and engineering problems associated with building design.
Article 46.1 (i)	Adequate knowledge of physical problems and technologies and of the function of buildings so as to provide them with internal conditions of comfort and protection against the climate.
Article 46.1 (j)	The necessary design skills to meet building users' requirements within the constraints imposed by cost factors and building regulations.
Article 46.1 (k)	Adequate knowledge of the industries, organisations, regulations and procedures involved in translating design concepts into buildings and integrating plans into overall planning.

3.5.3 Australian Institute of Architects

The Australian Institute of Architects founded in 1930, is the professional body for architects in Australia to provide professional support and advice for architectural community and advocate the value of architecture and architects. In addition the professional body is also responsible for setting standards for architectural education programs along with the Architects Accreditation Council of Australia (AACA) and Architect Registration Boards in each state and territory. According to the educations standards set forth by the above mentioned professional bodies, graduates exiting from an undergraduate program shall satisfy the following seven criteria:

1. Design Studies and Design Integration: This includes an understanding of the design theory and process followed by the ability to gather information, apply analysis and critical judgement.

2. Documentation and Technical Studies, which includes understanding building systems, and materials, and construction techniques.
3. History and Theory studies which includes awareness of philosophical, cultural and political movements as it relates to art and architecture, understanding history and theory of Western, non-western, regional and indigenous architecture, and the ability to inform action through knowledge of historical and cultural precedents in architecture
4. Practice and Project Management, and Implementation and User Studies including the process of awareness and understanding of the conventional building project cycle and the roles and responsibilities of the architects and other participants
5. Environmental Studies that focus on awareness of social and cultural dimensions of place, and awareness and understanding the concepts and issues of ecological sustainability.
6. Communication Skill which includes understanding about the growing theory of representation and how communication methods are integrally tied to methods and outcomes, and the ability to communicate ideas through the exercise of skills of collaboration, speaking, writing, drawing, modelling and evaluation,
7. Elective courses which can include but not limited to the awareness of the broader cultural context in which architecture is practiced, understanding of the specializations associated with the discipline of architecture and expand intellectual horizons beyond the core competency requirements of the architecture program.

3.5.4 Canadian Architectural Certification Board

In Canada architects are required to meet three common requirements for registration: education, professional experience, and examination. The education requirement consists of the B.Arch and M.Arch degree from a program certified by Canadian Architectural Certification Board (CACB). CACB was established in 1976 to set forth guidelines to certify the academic qualifications of individuals holding a professional degree/diploma in architecture who intended to apply for registration. The CACB degree equivalent requires 160 semester hours grouped into the following six subject areas:

1. General Education and Electives: This section refers to a minimum of 32 semester hours of credit in English/French Composition, Humanities, Social Science, Mathematics, and Natural Science.
2. History and Human Behavior: It requires at least 12 semester hours of history or architecture focusing on the study of construction by which human needs have been satisfied and human aspiration have been met, and six semester hours on human behavior which relates to the characteristics of individual and groups and its relationship to the physical environment in which they perform.
3. Environment: A minimum of three semester hours on environmental studies, which is defined as the basic principles of ecology as well as the actions with respect to environmental and resource conservation in architecture.
4. Design and Graphic Communication: A minimum of 50 credit hours of building design in a four level design studio sequence is required as part of the CACB requirement checklist. The design studio sequence is required to cover information from basic design within a non-building design context and spatial analysis, to simple projects with emphasis on user space study, and further to a more in depth total synthesis of a complex project and its related building systems.
5. Technical Systems: A minimum of 24 semester hours are required to be completed in the areas of structure systems, environmental control systems and construction materials and assemblies.
6. Finally six semester hours are required about the knowledge of profession which includes the legal and administrative context of architectural practice.

3.5.5 Council of Architecture, India

Unlike any other country discussed earlier, Council of Architecture of India requires all architectural students to qualify in the aptitude test in architecture before admission in an accredited institution. The aptitude test includes a section of aesthetic sensitivity and a section of drawing and sketching. The aesthetic sensitivity is to evaluate candidate's perception, imagination and observation, creativity and communication, and architectural awareness. The drawing aptitude is a test of the candidates (i) ability to sketch a given object proportionately and rendering with shade and shadow in visually appealing manner; (ii) sense of perspective drawing; and (iii) ability to create visual harmony using colours in given composition.

After admission into the architectural program the council requires all individuals to complete certain number of hours on the 18 selected topics in stage one and seven topics in stage two as shown in Table 5. Architectural education is broken into two phases where phase one is where students are introduced to the different topics and in phase two they apply that information in more complex design projects. The two phases are separated by a compulsory internship of six months to a year.

Table 5: Architectural education standards by Council of Architecture, India.

	Topics	Hours
PHASE I		
1	Architectural Design	540
2	Architectural Graphics Skills – Manual and Computer	360
3	Building Construction Technology	306
4	Structural Design and Systems	288
5	Basic Design and Visual Arts	180
6	History of Architecture, Art and Culture	126
7	Building Services and Equipments	90
8	Workshop Practice and Site Exposure	90
9	Building Materials and Sciences	90
10	Surveying and Leveling	36
11	Estimation, Costing and Specifications writing	72
12	Climatology, Environmental Studies and Landscape	63
13	Humanities	30
14	Human Settlements and Vernacular Architecture	30
15	Building Bye Laws and Codes of Practices	30
16	Theory of Design	63
17	Computer Applications in Architecture (Non-Graphic)	36
PHASE II		
1	Project (Thesis)	288
2	Architectural Design	216
3	Building Construction and Materials	108
4	Advanced Services	36
5	Advanced Structural Design and Systems	36
6	Professional practice	72
7	Research Skills and Project introduction	36
8	4 Electives from the sub topics: Housing, Urban Design, Interior Design, Construction Management, Landscape Design, Urban and Regional Planning, Architectural Conservation, Disaster Management, Architectural Journalism, Theatre/Film Set Design, Expert Systems Advanced Computing, Marketing Skills, Building Systems Integration, Visual Communication, Sustainable Architecture, Energy Conscious Architecture, Intelligent Buildings, Modular Coordination, Art in Architecture, & Environmental Studies	144

CONCLUSION

The goal of the study was comparing educational standards of architectural programs across the world. The goal was achieved through extensive search of the websites of different governing regulatory bodies of architectural education in the different countries around the globe and databases of organizations focusing on architectural education systems across the world. While results indicated that core requirements for architectural education showed high variation across countries, the areas of emphasis of the core requirements could be broadly categorized as design theory, technical systems, design documentation and professional practice.

REFERENCES

- COAC. 2005. Architectural Practice Around the World. International Union of Architects
- Crinson, Mark, and J. Lubbock. 1994. *Architecture--art Or Profession?: Three Hundred Years of Architectural Education in Britain*: Manchester University Press.
- Cruz, Jose Luis Gabriel. 2014. *What is Architecture? Steven Holl Describes It In Four words*. Archdaily 2013 [cited 25 Nov 2014]. Available from <http://www.archdaily.com/?p=425761>.
- Graby, John. 1989. *150 Years of Architecture in Ireland: RIAI, 1839-1989*: Riai.
- Hersey, G. 2001. *The Monumental Impulse: Architecture's Biological Roots*: MIT Press.
- Kostof, S. 2010. *A History of Architecture: Settings and Rituals*: Oxford University Press.
- Law, M, D Stewart, L Letts, N Pollock, J Bosch, and M Westmorland. 2011. *Guidelines for Critical Review Form - Qualitative Studies* 1998 [cited January 12 2011]. Available from <http://www-fhs.mcmaster.ca/rehab/ebp/pdf/qualguidelines.pdf>.
- Lawson, B. 2006. *How Designers Think*: Taylor & Francis.
- NAAB. 2014. *Home: National Architectural Accrediting Board* 2014 [cited November 11 2014]. Available from <http://www.naab.org/home>.
- Stevens, Garry. 2014. *A History of Architectural Education in the West* 2001 [cited 22 Nov 2014]. Available from <http://www.archsoc.com/kcas/Historyed.html>.
- Weatherhead, Arthur Clason. 1941. *The history of collegiate education in architecture in the United States*: Columbia university.

Appendix 1 - Architectural Education Standards and Requirements of Various Nations

Country	No. of Archs.	Population	No. of Arch School	No. of Arch Student	Presence of Edu. Standard	Arch. Edu. Dur.	Internship Option	Mandatory	Internship Dur.
Argentina	42,000	41,803,125	31	44	Y	6	Y	N	3
Armenia	1,200	2,983,990	2	250	Y		N	NA	
Australia	11,605	23,630,169	23	5,486	Y	6	N	NA	
Austria	3,322	8,396,760	8		Y	5	Y	Y	3
Bangladesh	1,181	158,512,570	4	900	Y	5	Y	Y	2
Belarus		9,307,609	5		Y	5	Y	Y	2
Belgium	11,500	11,144,420	26		Y	5	Y	Y	2
Benin	107	8,519,000	1		Y		Y	Y	
Bolivia	5,265	10,847,664	3	1,500	Y	6	N	NA	
Brazil	80,000	202,033,670	83	8,500	Y	5	N	NA	
Bulgaria	4,178	7,167,998	2		Y	5	N	NA	
Canada	7,500	35,524,732	35		Y	5	N	NA	
Chile	9,000	17,772,871	21		Y		Y	Y	
China	36,000	1,393,783,836	77	32,000	Y		Y	Y	2
Colombia	33,300	48,929,706	21		Y		NA	NA	
Congo	70	69,360,118	1		N	5	Y	N	3
Costa Rica	2,003	4,937,755	8	2,145	Y		N		
Croatia	3,000	4,272,044	2	920	Y	5	Y	Y	2
Czech Republic	2,921	10,740,468	8	5,000	Y		N	NA	
Denmark	6,000	5,640,184	4		Y	5	Y	N	0.5
Ecuador	13,400	15,982,551	9	5,250	Y	5.5	Y	Y	3
Egypt	19,954	83,386,739	15	5,123	Y	variable	Y	Y	variable
Estonia	700	1,283,771	2	105	Y		N	NA	
Finland	3,500	5,443,497	9	1,600	Y	5	N	NA	
France	26,964	64,641,279	44	19,000	Y	BA 3 MA 2	Y	Y	5
Georgia	2,500	4,322,842	2	500	Y		Y	Y	2
Germany	50,000	82,652,256	92	41,759	Y	BA 5 +exam	N	Y	3
Greece	15,756	11,128,004	8	5,000	Y	BA 3 MA 2	N	NA	
Honduras	450	8,260,749	1	1,300	Y	6	N	NA	
Hong Kong	2,040	7,259,569	5	500	Y	5	N	NA	
Hungary	4,000	9,933,173	5	300	Y	5	N	NA	
Iceland	314	333,135	1		Y	BA3-4 MA 2	Y	Y	2
India	25,000	1,267,409,849	80		Y	5	Y	Y	0.5
Indonesia	6,000	252,812,245	10		Y	5	Y	Y	3
Iran	3,400	78,470,222	10	8,000	Y	5	Y	Y	2
Ireland	2,500	4,677,340	8	400	N		Y	Y	
Israel	7,000	7,822,107	6	1,000	Y	5	Y	Y	2
Italy	111,063	61,070,224	35		Y	5	Y	Y	3
Japan	307,558	126,999,808	95	80,000	Y		Y	Y	
Latvia	1,200	2,041,111	1		Y		Y	Y	
Lithuania	2,700	3,008,287	3	838	Y	5	Y	N	2
Luxembourg	600	536,761	1		N	4	Y	Y	1
Macedonia	3,000	2,108,434	1	500	Y	4	Y	Y	5
Malaysia	3,167	30,187,896	8	1,898	Y		Y	Y	
Malta	515	430,146	1	237	Y		Y	Y	
Moldova	670	4,295,000	1		Y		Y	Y	
Netherlands	8,350	16,802,463	15	2,280	Y	5	Y	Y	1
New Zealand	1,650	4,551,349	11	175	Y		Y	Y	1
Nigeria	4,500	178,516,904	21	10,000	Y	5	N	NA	
Norway	3,800	5,091,924	8		Y	5-6	Y	Y	2
Palestine	1,074	2,731,052	2	450	Y	BA 4 MA 2	Y	Y	2

Country	No. of Archs.	Population	No. of Arch School	No. of Arch Student	Presence of Edu. Standard	Arch. Edu. Dur.	Internship Option	Mandatory	Internship Dur.
Philippines	16,000	100,096,496	36		Y	5	N	NA	
Poland	13,500	38,220,543	16	6,770	Y		Y	Y	
Portugal	12,113	10,610,304	10	9,302	Y	5	Y	Y	2
Puerto Rico	1,027	3,683,601	5		Y		Y	Y	
Romania	5,500	21,640,168	7	615	Y		Y	Y	
Russia	11,883	142,467	33	5,000	Y		Y	Y	
Serbia & Montenegro	8,000	9,468,378	3	1,000	Y	5	Y	Y	1
Sierra Leone	20	6,205,382			N	3-6	Y	Y	2
Singapore	1,469	5,517,102	3	617	Y	4-5	Y	N	
Slovakia	2,500	5,454,154	2	1,400	Y	6	Y	Y	5
Slovenia	1,200	2,075,592	1	700	Y	4.5	Y	N	
Korea	10,140	49,512,026	66	12,000	N	5	Y	Y	3
South Africa	4,271	53,139,528	18	800	Y	5	Y	N	2
Spain	40,741	47,066,402	37		Y	4.5	Y	Y	2
Sri Lanka	485	21,445,775	1		Y	6	Y	Y	3
Sudan	800	38,764,090	1	1,300	Y		Y	Y	
Sweden	5,376	9,631,261	8	1,300	Y		N	NA	
Switzerland	5,330	8,157,896	15	3,000	Y		Y	Y	
Tanzania	171	50,757,459	2		Y	4	N	NA	
Trinidad & Tobago	100	1,344,235	1		No School		Y	Y	3
Tunisia	1,400	11,116,899	5		Y		Y	Y	
Turkey	29,655	75,837,020	45	5,000	Y		N		
Ukraine	7,100	44,941,303	17		Y	5	Y	Y	2
United States	102,000	322,583,006	397	36,300	Y	3-4 + 2	Y	Y	3
United Kingdom	30,399	63,489,234	187	10,000	Y	5	Y	Varies	3
Uzbekistan	1,099	29,324,920	3	550	Y		N		
Venezuela	13,000	30,851,343	28		Y		N		
Vietnam	8,500	92,547,959	6		Y	BA 3 MA 2	Y	Y	1
Zimbabwe	100	14,599,325			Y		Y	Y	

Appendix 2 - Number of Architectural School in each individual Nation. This table only lists the countries not listed in Appendix 1.

	Country	No. of Arch Schools
1.	Albania	1
2.	Azerbaijan	2
3.	Bahrain	1
4.	Bhutan	1
5.	Bosnia Herzegovina	2
6.	Burma	1
7.	Burundi	1
8.	Cambodia	1
9.	Cape Verde	1
10.	Cuba	4
11.	Cyprus	4
12.	Dominican Republic	4
13.	El Salvador	8
14.	Ethiopia	3
15.	Ghana	1
16.	Guatemala	4
17.	Guyana	2
18.	Haiti	1
19.	Iraq	4
20.	Jamaica	2
21.	Jordan	4
22.	Kazakhstan	6
23.	Kuwait	1
24.	Kyrgyzstan	1

	Country	No. of Arch Schools
25.	Lebanon	6
26.	Liberia	1
27.	Libya	1
28.	Nepal	1
29.	Nicaragua	3
30.	North Korea	1
31.	Pakistan	8
32.	Panamá	3
33.	Papua New Guinea	2
34.	Paraguay	1
35.	Perú	9
36.	Saudi Arabia	6
37.	Somalia	1
38.	Swaziland	1
39.	Syria	4
40.	Tajikistan	1
41.	Thailand	11
42.	Togo	1
43.	Türkmenistan	2
44.	Uganda	2
45.	United Arab Emirates	10
46.	Uruguay	4
47.	Zambia	2

Emerging technologies and disruptive programming research in the design studio

Gregory Stroh¹

¹Kent State University, Kent, OH

ABSTRACT: A persistence of technological innovations has called into question the traditional values of urban space and what a future of pervasive technology may mean for the ideal model of urbanism. The influence of technology lies within its ability to adapt and invent, often redefining a technology's performance within the context of a given market over short periods of time, rendering earlier generations of similar technology obsolete. Referred to as disruptive technology, this innovation is a new technology that unexpectedly displaces an established technology. Through a knowledge transfer ideal, the study involves a trans-disciplinary understanding of architectural and urban spatial practices in which the concept of disruptive programming is derived, understood, and ultimately applied. The central objective of this ongoing study is to create the facility within students to re-define and interpret, then strategically position project programming in order to study its effects upon spatial assemblies through an engagement with the proliferation of data and an understanding of the powerful presence of emerging technologies. Recent research of this set of disruptive technologies is analyzed through multiple scales and within multiple contextual situations confronting and questioning the standard methods of programming our built environment. The research was initially isolated within the emerging technology discipline, ultimately contextualized to study its potential in an architectural setting, such as its role in creating urban effects, its influence on project programming, and at the intimate scale, the tracking of an individual's habits or routines through sensors. This research has shown that standard programmatic processes must react to the ever changing nature of a future driven by pervasive technological disruption. Through a concise calibration of programming iterations and a re-interpretation of spatial assembly, we have seen the emergence of new forms and more importantly, new types of space, both within the urban and architectural scales.

Key Words: Disruptive Programming, Disruptive Technologies, Innovation, Technology

INTRODUCTION

The ambition of the studio has been to map the main issues linked to the development of architectural programming's recently established relationship with the issues and problems raised by the behaviors associated with technological advancement, both by the technology/device and the preoccupied user. Based upon our fields continuing reliance on multi-disciplinarity, it is my assertion that students who are taught and ultimately practice this [research] model of disruptive architectural programming will add to their knowledge base and have advantage within the shifting relationships of our economic, social, cultural, political, and environmental landscapes which exert a rapidly increasing influence in the processes of architecture and urban design at multiple scales.

The study intends to exhibit the processes and products of a combined programming seminar and graduate design studio that had a commitment to the significance of studying technologies' roles in architectural programming. Through a knowledge transfer ideal, this method involves a trans-disciplinary understanding of architectural and urbanistic spatial practices in which the concept of disruptive programming is derived, positioned, and ultimately deployed. But before I advance the attributes associated with our interpretation of disruptive programming, one needs to understand what's behind the disruptive technologies veil and their programmatic potential.

Essentially, three terms are used here to describe technologies; emerging, sustaining, and disruptive. The broadest use term is emerging as it contains innovations from a vast landscape following a typical growth curve. The core of the study develops from the distinction between sustaining technologies and disruptive ones. The former produce incremental improvements in the performance of established products, potentially leaving gaps in overlooked or unexamined market segments. In contrast, disruptive technologies are "innovations that result in worse product performance, near term", yet reach new markets, eroding their competitor's position through routine technological advancements and the appeal of perceived value for the less demanding end of the market. (Christensen 1997, 192)













	Illustrative rates of technology improvement and diffusion	Illustrative groups, products, and resources that could be impacted ¹	Illustrative pools of economic value that could be impacted ²
	55 million vs. 1460¹ Price of the fastest supercomputer in 1975 vs. that of an iPhone 4 today, equal in performance (MFLOPS) 6x Growth in sales of smartphones and tablets since launch of iPhone in 2007	4.3 billion People remaining to be connected to the Internet, potentially through mobile Internet 1 billion Transaction and interaction workers, nearly 40% of global workforce	\$1.7 trillion GDP related to the Internet \$25 billion Interaction and transaction worker employment costs, 70% of global employment costs
	100x Increase in computing power from IBM's Deep Blue (chess champion in 1997) to Watson (Jeopardy winner in 2011) 400+ million Increase in number of users of intelligent digital assistants like Siri and Google Now in past 5 years	220+ million Knowledge workers, 9% of global workforce 1.1 billion Smartphone users, with potential to use automated digital assistance apps	\$9+ trillion Knowledge worker employment costs, 27% of global employment costs
	300% Increase in connected machine-to-machine devices over past 5 years 80-90% Price decline in MEMS (microelectromechanical systems) sensors in past 5 years	1 billion Things that could be connected to the Internet across industries such as manufacturing, health care, and mining 100 million Global machine to machine (M2M) device connections across sectors like transportation, security, health care, and utilities	\$36 trillion Operating costs of key affected industries (manufacturing, health care, and mining)
	18 months Time to double server performance per dollar 3x Monthly cost of owning a server vs. renting in the cloud	2 billion Global users of cloud-based email services like Gmail, Yahoo, and Hotmail 80% North American institutions hosting or planning to host critical applications on the cloud	\$1.7 trillion GDP related to the Internet \$3 trillion Enterprise IT spend
	75-85% Lower price for Baxter ¹ than a typical industrial robot 170% Growth in sales of industrial robots, 2009-11	320 million Manufacturing workers, 12% of global workforce 250 million Annual major surgeries	\$6 trillion Manufacturing worker employment costs, 19% of global employment costs \$2-3 billion Cost of major surgeries
	7 Miles driven by top-performing driverless car in 2004 DARPA Grand Challenge along a 150-mile route 1,640 Miles cumulatively driven by cars competing in 2005 Grand Challenge 300,000+ Miles driven by Google's autonomous cars with only 1 accident (which was human-caused)	1 billion Cars and trucks globally 450,000 Civilian, military, and general aviation aircraft in the world	\$4 billion Automobile industry revenue \$160 billion Revenue from sales of civilian, military, and general aviation aircraft
	10 months Time to double sequencing speed per dollar 100x Increase in acreage of genetically modified crops, 1996-2012	25 million Annual deaths from cancer, cardiovascular disease, or type 2 diabetes 2.5 billion People employed in agriculture	\$6.5 trillion Global health-care costs \$1.1 trillion Global value of wheat, rice, maize, soy, and barley
	40% Price decline for a lithium-ion battery pack in an electric vehicle since 2009	1 billion Cars and trucks globally 1.2 billion People without access to electricity	\$2.5 trillion Revenue from global consumption of gasoline and diesel \$100 billion Estimated value of electricity for households currently without access
	80% Lower price for a home 3D printer vs. 4 years ago 4x Increase in additive manufacturing revenue in past 10 years	330 million Manufacturing workers, 12% of global workforce 8 billion Annual number of toys manufactured globally	\$11 trillion Global manufacturing GDP \$85 billion Revenue from global toy sales
	\$1,000 vs. \$50 Difference in price of 1 gram of nanotubes over 10 years 115x Strength-to-weight ratio of carbon nanotubes vs. steel	7.6 million tons Annual global silicon consumption 45,000 metric tons Annual global carbon fiber consumption	\$1.2 trillion Revenue from global semiconductor sales \$4 billion Revenue from global carbon fiber sales
	3x Increase in efficiency of US gas wells, 2007-11 2x Increase in efficiency of US oil wells, 2007-11	30 billion Barrels of oil equivalent in natural gas produced globally 30 billion Barrels of crude oil produced globally	\$80 billion Revenue from global sales of natural gas \$3.4 billion Revenue from global sales of crude oil
	85% Lower price for a solar photovoltaic cell per watt since 2010 10x Growth in solar photovoltaic and wind generation capacity since 2000	21,000 TWh Annual global electricity consumption 13 billion tons Annual CO ₂ emissions from electricity generation, more than from all cars, trucks, and planes	\$3.5 trillion Value of global electricity consumption \$80 billion Value of global carbon market transactions

Figure 1: Speed, Scale, and Economic Value of 12 Potentially Economically Disruptive Technologies. Source: (McKinsey Global Institute 2013)

1.1. Disruptive technologies

Five sections, one for each technology, will consist of a brief background for each disruptive technology, followed by conceptual implications for architectural program and the spatial assembly process. As resources are shaped and processed through technology, the analysis utilizes technology's enabling role in the operation of social and cultural networks, the market economy, and environmental concerns. A multi-scalar approach allows the capacities of each scale to present their limits, as each scale produces one view of the system, yet simultaneously calls into question the performance of the coherent whole. Disciplinary migration creates new opportunities to study and utilize disruptive technology's transformative potential to reconfigure traditional programming techniques – a study of the reciprocal relationship between disruptive programming and the physical environment. The following rapidly advancing technology areas have been cited as having the greatest potential for transforming life, business, and the global economy (Manyika 2013).

1.2. Cloud technology

Cloud technology allows the delivery of potentially all computer applications and services through networks or the Internet. With cloud resources, the bulk of computational work can be done remotely and delivered online, potentially reducing the need for storage and processing power on local computers and devices. The cloud also enables pay as-you-go models for consuming IT, as exemplified by the phrase "infrastructure as a service." The cloud enables some of the most highly impactful technologies – mobile internet, automation of knowledge work, and the Internet of Things. Since apps often rely on cloud resources, the cloud is

expected to be a major driver of smartphone use. Through its processing power and efficient streamlining, the cloud already has and will continue to impact the workplace. Adjustments to the off-site | off hours concept is accelerating, while the new employee arrives with a varied set of expectations and standards further delaminating the GPS of the office.

1.3. Internet of things [IOT]

The Internet of Things refers to the use of sensors, actuators, and data communications technology built into physical objects—from roadways to pacemakers—that enable those objects to be tracked, coordinated, or controlled across a data network or the Internet. There are three steps in [IOT] applications: capturing data from the object, aggregating that information across a data network, and acting on that information—taking immediate action or collecting data over time to design process improvements. IOT can be used to create value in several ways. In addition to improving productivity in current operations, the Internet of Things can enable new types of products and services and new strategies: remote sensors, for example, make possible pay-as-you-go pricing models such as Zipcar. IOT technology ranges from simple identification tags to complex sensors and actuators. Several technological advances are improving the effectiveness of IOT applications while also reducing costs. The price of RFID tags and sensors is falling, and new developments such as MEMS are enabling new uses. The impacts have incredible depth and breadth. The Internet of Things is an important enabler of better management of infrastructure systems. IOT has broad operational effects upon the urban and agricultural landscapes, from products to services and through individual or serial production.

1.4. 3D printing [3DP]

3D printing belongs to a class of techniques known as additive manufacturing. 3DP has several advantages over conventional construction methods. An idea can go directly from a file on a designer's computer to a finished part or product, potentially skipping many traditional manufacturing steps. 3DP has other notable characteristics such as an improving performance curve [reduction of cycle times in design and construction], an expanding array of materials to print, and a rapidly declining price structure. An oft overlooked attribute is its allure in creating a subculture. Belonging to a given culture means, in part, having fluency in its infrastructural languages, and the 'maker' subculture is flourishing. This simple fact has had wide ranging effects. Material infrastructures function by seamlessly binding hardware and internal social organization to wider social structures. It nimbly does so through scale and through its inherent shape shifting characteristics. I refer to its potential to 'act' as product, service, device and programmatic element. Its unexpected collection of functionality makes this position as a disruptive programming element possible.

1.5. Augmented reality

Augmented Reality is a technological modification of existing senses for enhanced information processing. This technology has mainly explored the alteration of one's visual experience through a Heads Up Display that overlays the individuals line of sight with hardware such as smart phones and Google glass. Correlation of architectural process and augmentation become flexible, and catalytic. In the same way that this technology augments user's senses, it is also capable of alerting the limits of both physicality and practicality of architectural form. Infrastructure no longer becomes a necessity of traditional spatial practices, making it possible to create complex programmatic conditions with very minimal physical space.

1.6. Mobile internet

The growth of the internet has made it a resource of high demand, resulting in a global market of pervasive connectivity. This allows the breadth of technologies to persist through time and space, making the internet a complete and necessary infrastructure, albeit invisible in the traditional sense unlocking new ways of knowing, perceiving, and interacting with the physical world to users everywhere. Through this connectivity they have been given the ability to access information seamlessly. As a disruptor this technology theoretically makes the need for direct human contact, and potentially entire tactile environments irrelevant. This posits the notion that program can persist without traditional confines such as space, time or demand, allowing program to exist everywhere [or nowhere] based on the individuals need to access it through mobile computing devices. Most importantly program is no longer directly anchored to scale.

2.0 METHODS

The research approached these developments from an infrastructural perspective and sought to define a corresponding architectural *reaction* to technology as disruptive program. Through moments when the permanence of architecture meets the ephemeral qualities of technology, disruptive programming allows for the experience of permanent spatial practice to become dislodged from a single predefined parameter, and

open to becoming a more dynamic response to the needs of its environment. A primary goal was to understand how architecture can respond to frequent programmatic change as a result of technological innovation by using associative disruptive technologies and innovations as a basis for a reimagining of traditional spatial practice. It can be driven by an evolution of culture, not an evolution of technologies directly; the behavioral changes, the physical changes and reflexes brought about by the computer's active role in daily ritual. Expectations of culture are redefined with design objectives and procedures.

Films...have envisaged changes in the perception of ordinary space brought about by the development of sophisticated interfaces between ordinary and digital space. The notion of enhanced or increased reality suggests a different materiality made possible by the hybridization of the physical and the digital. While this hybridization is not fully developed, some features of the displacement of materiality are already evident.

(Picon 2010, 119).

As multi-disciplinary knowledge and collaborations become increasingly valuable, this study begins seemingly on or near the 'edge' of conventional architectural thought. It questions the center and the periphery, ceding its migration across scales and disciplines. Studying the set of *disruptive technologies* in isolation as a separate undertaking allows for a biased interpretation, and a resolute position. Sequentially analyzed and synthesized within a directed set of contextual situations allowed for the re-consideration of the relationships between technology and space which are not simply the quantification of one directly adapting to the rules of the other. In isolation the contrast of these two forces is more than the application of design principles from one to the other. Instead it is the result of a cultural clash, creating rifts in reality, and layering the physical with technological posterns. This amalgamation of technology and design as a new and evolving form of program development gives a new perspective to architectural possibilities. The result is a future of disruptive programming.

Calibrating a rhythm of research inside and outside of architecture created opportunity for experimentation in manufacturing effects by tracking, translating and visualizing data, directed through readings, case studies review, and a sequence completely outside the discipline, where we slipped into and out of management information studies. Programming strategies & tactics emerged through the questioning of material and [im]material concerns; the physical, spatial, and relational within related scales and contextual situations. The following summarize the seminar guidelines under consideration; the accessibility and interpretation of Big Data, the notion of material and [im]material infrastructures, the advancing influence of technology, situating program as a material construct within multiple scales, and the transformative potential of traditional programming techniques.

2.1. Tactile environments

Unlike the internet, the urban landscape is bound by physical parameters that hold no influence on data space. These parameters make the corporeal realm a static, slowly adapting landscape, the ways in which cyberspace can connect and manifest are impossible to replicate physically, politically, or economically in the built environment. The landscape of this environment serves as active surface, a structure for facilitating conditions necessary for relationships and interactions to be linked through the functions that it supports. The urban surface isn't just the space between buildings, but rather the extensive and inclusive ground plane of the city which accommodates buildings, roads, utilities, open spaces, neighborhoods, and habitats.⁴ Contemporary forms of urbanization look at the city as the result of consequential shifts in the fundamental paradigm, effectively moving it away from a formal interpretation or typological assessment, and towards a greater understanding of the dynamic systems of which the city is comprised.

This connective tissue formed through the juxtaposition of permanent infrastructure reveals the impact left by various cultural developments echoed through stylistic design vernacular. Schouwburgplein, a Rotterdam based design by West 8, is a project that examines notion of urban emptiness. Landscape architect Adriaan Geuze believes that urban dwellers are able to create, adapt to, or imagine whatever they want and therefore over-programming a space is a less effective design approach. Instead what is more important is giving the urban consumer a space in which they can find their own meanings in the environments they use. Schouwburgplein is meant to be a place where the public can modify and appropriate the urban surface of the city by creating surfaces that are simple yet are capable of supporting many different types of events.⁵ Because the space is surrounded by amenities such as theaters, restaurants, and cafes the project acts as a single public armature between all of these programs, giving them the ability to morph into the space.

3.0 DISRUPTIVE PROGRAMMING SPECULATIONS

Today technology has become a driving force of alteration causing the fragmentation of disparate programs, while at the same time creating opportunity for the urban surface to thrive. Mobility and more so the social communities that have been created since the birth of the internet have forced designers to adapt spatial practices by encouraging flexible, multifunctional surfaces. Traditional and sustained programs at various scales have changed very little since their conception.

To manufacture disruptive program one must first isolate a function to its core. In isolation certain program functions which may be viewed through a modern standard as archaic can be distilled. After a programmatic deconstruction a building function can be reformed, removing the familiar perception of function and replacing it with a perspective driven by a new objective. In the case of this argument the reorientation of building function will occur as a reconstructed response to disruptive technology by taking familiar programmatic notions and manifesting possible outcomes, repositioning them with potential disruptors. The research examines two instances of disruptive technologies' impact on urban and architectural programming in the information age.

3.1. Student project 1

The first study examines the notion and execution of four conceptual programs and their urban and architectural impacts at a standard block scale. These programs are identified as a Theatre, Marketplace, Public Space, and Archive.

Theatre: Augmented reality offered the possibility of the largest spatial consolidation. In this case visual interfacing has the ability to rescale events of multiple sizes and across distances, giving users the ability to experience many different events simultaneously in a tactile environment. Consider conventions, stadiums, concerts, lecture hall, cinema, and theatre as programs that form social experiences in any number of physical spaces, creating a program that is only reliant on personal, wearable devices.

Marketplace: The possibility for both commercial and institutional research has become streamlined through three dimensional printing. Production and consumption are no longer hindered by time, costs, or the product inflexibility of traditional distribution. This allows for design and sharing of user generated content to be instant and customizable. Purchasing any items is a matter of the user's desire and interest, allowing for companies and individuals to be the providers, rather than the definers of content. Programmatically this translates largely to boutique, online, and big box style shopping; or dry and wet lab style research, while also allowing for the possibility to serve cultural functions as a gallery space.

Public Space: Media docking refers directly to the relationship between user and device. Conceptually parking refers directly to human and autonomous occupation of space. Programmatically the media dock occupies instances where the user is typically a body at rest, identified by functions that are inhabited or require seating, such as cafes, lobbies, restaurants, or park benches. This program leverages the need to recharge peripherals into a social function by connecting and sharing data with local users, facilitating both the sharing of content, and the potential for exchange between people based on data processing and feedback.

Archive: The cloud collection is a wireless database existing on linked servers, accessible within the building footprint. Without physical collection, all content exists as data which can be displayed on mobile or static surfaces in a tactile environment. This collection gives users access to licensed software, content developer kits, and various forms of media sharing capabilities. As part of a larger digital network users can navigate other buildings of the same format globally, and manifest their own ways of using data space. Developed as a digital reinvention of the archive the functionality also allows for programs such as libraries, offices, and classrooms to take advantage of the clouds disruptive potential.

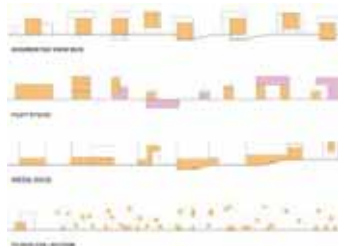

Figure 2: Sectional Studies of Conceptual Programs. Source: (Reindel 2014)

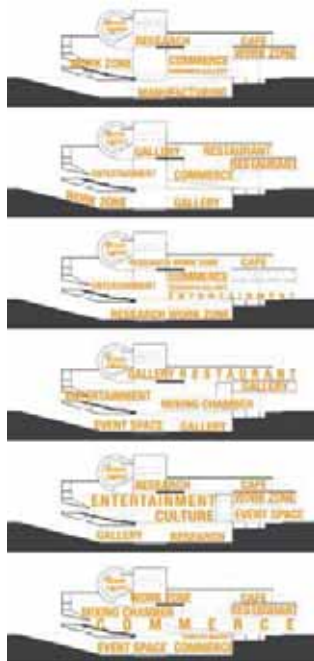

Figure 3: Section Model of Program Assembly Configurations. Source: (Reindel 2014)

Due to the unquantifiable physical potential of disruptive technology and its impacts on both culture and the built environment, the working design followed the same notions of urban emptiness enacted in the design of Schouwburgplein. For a tactile space to react to technological change, it must have a degree of freedom so that these conceptual programs can be invented and executed within its confines. The programs conceived were examined through section in a series of diagrams.

A permanent, multi use volume was devised for each concept based on standard programs best suitable for the supporting disruptive technology. Using the Augmented view box as an example, the physical spatial requirements were met by providing sloped seating and a modular stage for standard performances or lectures. Over the course of a day the form could change based on the users demand and accessibility to technology. If implemented today, the space would provide a standard theater experience, but as technology adapts, and wearable visual interfacing becomes common, users can adapt the space to suit their interests or programmatic needs. Instances of multi scalar, event based programming can alter the boundaries of the architectural form. Through the use of a modular sliding construction, a series of configurations can be explored to feed the different programs into each other through the central conduit space.

This temporal based activation can take a cinema and turn it into basketball court, going from a confined program, to a building wide occupancy that engages all of the internal programs simultaneously. This process also allows two opposing volumes to merge together either horizontally or vertically to provide different spatial assemblies, capable of providing drastically different canvases for new functions to be conceived, both inside the building form and into the adjacent public spaces.

3.2. Student project 2

The second study is a speculation of the deterioration of post-industrial neighborhoods, its failings, its implications, and its hidden opportunistic traits within our digital culture. The notion of sustained industry and the emerging DIY maker culture is conceptually linked as this unlikely merger re-configures the conditions of urban habitation at multiple scales and within multiple contextual situations – the social, cultural, economic, political, and spatial. The inherent ethos of the open source DIY mentality will ameliorate the lines of distinction between neighborhood and business district, home and factory, resident and worker.

The premise is economically, and perhaps, technologically biased as the hope is for a socioeconomic accelerant through an infusion of industry and architectural programming in a depressed community. Equitable revitalization calls for both preserving and creating, as well as taking steps to minimize untimely

and forced displacement of a neighborhood's lower-income resident. A phased revitalizing proposal introduces a disruptive technology, 3D printing [infused industry] into a local node [the distressed | dismissed neighborhood] deploying the contained 'service' function of technology, replacing the typical, orthodox programmatic element, creating a series of changing spaces around it – from the mediatic and didactic to the collective and individual.

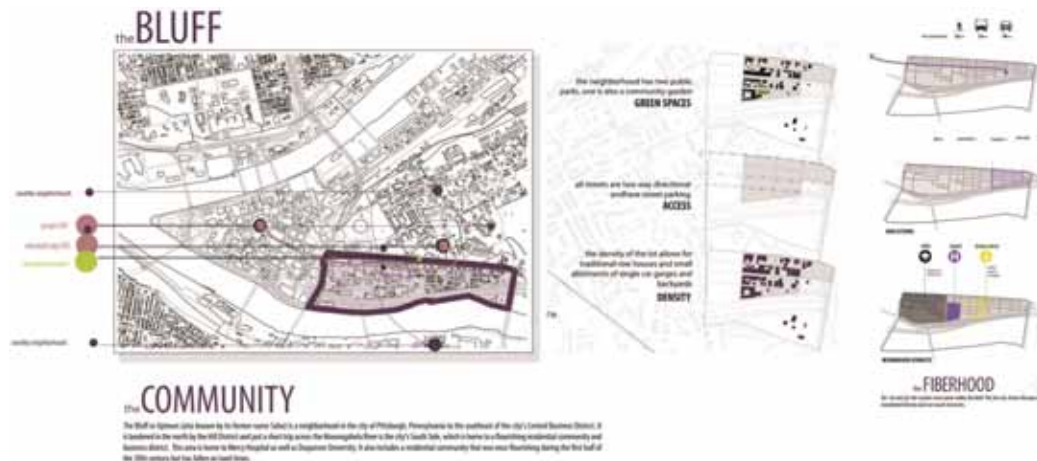

Figure 4: Site Analysis Diagram. Source: (Walker 2014)

An ambition for the project is to offer the neighborhood a dynamic and variable meeting point for people of all ages taking part in a wide range of planned and un-planned activities. The disruption creates a viable context for our current production and inventory model as it creates a new market and value network, ultimately, altering and displacing current technology. 3DP's market for producing complex, low volume, highly customizable parts markedly shifts the current model on many fronts; including the lessening of waste and the carbon footprint, the re-partitioning of land due to reduced inventory, and the reduction in cycle times in design and production.

Ideally, the site is transformed into an integrative hyper-connective territory [fiberhood] through an unseen infrastructure of high speed fiber, where access and assets, both knowledge and other, are freely exchanged resources open to the broader public. The land work strives to be surfacial and deep as well as aesthetic and utilitarian. Deemed infrastructural, the territory holds differing combinations of materials | topography and flexible, activated public spaces. Viewed as an active 3D surface in this iteration, program is deployed through existing housing stock and new construction points with mobile 3DP huts, the ANCHOR [work | social incubator], the gardens consisting of activity zones, isolation zones, connector zones, and a conveyor system | park. 3DP assembly is understood here as a hybrid condition where normative construction techniques are used on-site with intended 'gaps' in construction for the off-site customized 3DP building elements to be inserted. As assembly is fast tracked, an inherent attribute of 3d printing, the sites for design and construction merge into one cohesive landscape.

The formatting of a 3DP distribution network | urban design strategy has created a cultural network through its physical proximity and global reliance upon other infrastructures. Exercising the scaling and scaffolding effects of 3D printing through a design project has conflated such issues as innovation in education, reaching disconnected markets, direct and indirect relationships with other emerging technologies, bridging between traditional design and building techniques and emerging ones, and conceptual | pragmatic issues concerning the labor force.¹⁰ The project acts on many levels; re-invigorating a sagging urban brand [PIT], upping the socio-economic ante of a blighted neighborhood, producing an economic boost to a municipal landscape, contributing global presence through an aggressive risk taking strategy, ultimately, reflecting on processes of encountering cities.

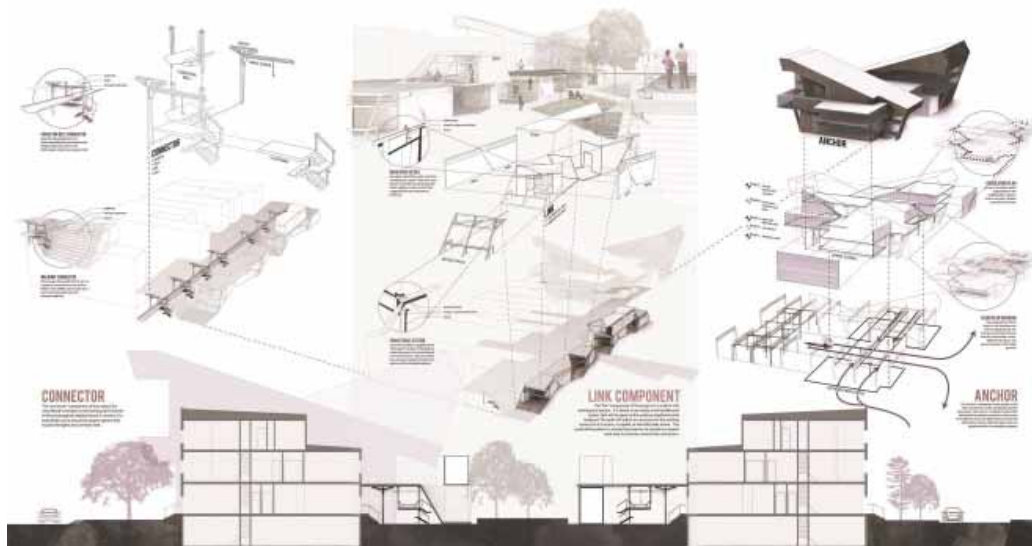

Figure 5: Disruptive Program Spatial Assembly. Source: (Walker 2014)

4.0 ANALYSIS AND ASSESSMENT

The studio approached the studies amongst technology, design, and economies, initially through a monocular lens, quickly realizing the essential need and value of the multi-disciplinary view of practice. Two stages of analysis and assessment took place; the first was a verbal presentation of teams of 2 students and review with a multidisciplinary set of reviewers, while the 2nd level of assessment was based upon the specific technology's integration into the individual student's architectural studio project. The research was initially isolated within the emerging technology discipline where students were able to learn the specifics of the terms, definitions, language and trade lingo, processes, products/services, eventually migrating to an awareness and understanding of technology transfer issues, the layering of knowledge communities, and ultimately its potentials for testing in an architectural study, such as its role in creating urban effects, its influence on project programming, and at the intimate scale, the tracking of an individual's habits or routines through sensors.

Co-construction of knowledge was well established within the student work; there was an apparent ease when manipulating the data as teams, the resistance and difficulties arose from the direct application within the confines of an architectural program, developed by individuals for the remaining portion of studio. The speculations regarding the material influences of technologies was difficult for some to grasp, as most students had previously been 'given' a program to organize and design, thus the singular authorship of program was novel, initially a time consuming undertaking. The various positions in studio were within an acceptable gradient, with the two (Reindel, Walker) presented in depth being the most developed and most appropriate in expressing the variable and scalar approaches to this design probe. Composed of seven M.Arch students, four M.Arch | M.B.A. students and one M.Arch | M.U.D. student, discussion and debate was lively, insightful, and often territorial. The levels of engagement stayed within disciplinary boundaries as the dual M.Arch | M.B.A. students nimbly moved through the exercises and appreciated the cross disciplinary ideas of practice in the studio setting. Neil, the M.Arch | M.U.D. candidate whose project is detailed in the paper, expressed an exuberance, and at times, an overabundance of trade lingo within his studies, but excelled at developing and translating the concept all the way through his project. The M.Arch.

students were divided as some waived and tended to overlook the growing influence of technology for almost the entirety of the project while the remaining few engaged the novelty of manipulating a re-discovered active agent in architectural programming.

A student generated studio summary follows.

Architecture has become an entity that is no longer just for people, but for peripherals. Inhabited by devices that hold potential only limited by the user's imagination, digital technology [disruptor] serves as a catalyst to fixed architectural programming [disruptee]. With time, the power and impact of these technologies will continue to challenge the built environment. This research has shown that standard programmatic processes must react to the ever changing nature of a future driven by pervasive technological disruption. Through the concise oscillation of program and spatial practice, new forms, both urban and architectural can begin manifesting into an innovative, disruptive programmatic model. (Graduate Studio 2014).

Through this programming exercise we were able to comprehend a significant modification of past practices through a loosening of traditional relationships and constraints, fundamentally recreating a structure's organization, shape, and scale. Specifically, the two student projects have demonstrated the proposition that project programming can become generative through a socio economic approach to the problems associated with computation and space.

Systemic integration supports and sustains design's impact beyond the visible, object based outcome. Contextual consciousness vividly illustrates the acceleration of change taking place around us and begins to situate design as an infrastructural component. "It's really about thinking about the often-invisible systems that are supporting our way of living. It's thinking about the context in which we are living, as an ecology that sustains process." (Mau 2011). Design authorship and pragmatic acumen have not faded, but are re-aligned with emerging notions of the identities of material, product, service, lifestyle, and programmatic disruption.

Yet it contributes to the search for a new materiality in architecture and "...the crucial role of concrete sensory experience and what I [sic] have called materiality, in other words our relation with the physical world" (Picon 2010, 212). With further iterations, this mode of study should have a critical effect upon both, traditional and emerging building design/practices. Embedding technology with program or conversely, embedding program with technology has required a re-imagination of architectural programming in response to the emerging socio-technological desires as well as the way we conceive architecture.

REFERENCES

- Christensen, C. 1997. *The Innovator's Dilemma*. Boston, Massachusetts: Harvard Business School Press.
- Graduate Design Studio, 2014. *Programming Seminar Statement*. Kent, OH.
- Manyika, J., Chui, M., Bughin, J., Dobbs, R., Bisson, P. and Marrs, A. 2013. *Disruptive Technologies: Advances That Will Transform Life, Business, and the Global Economy*. Brussels Belgium: McKinsey Global Institute.
- Mau, B., 2011. A conversation with Bruce Mau: re-thinking the role of design in shaping of our future. Retrieved from <http://catalystreview.net/>.
- Picon, A. 2010. *Digital Culture in Architecture*. Basel, Switzerland: Birkhauser.

Fieldwork in ritual reality: A qualitative method in architectural research

Marja Sarvimäki¹

¹University of Hawai'i at Mānoa, School of Architecture, Honolulu, HI

ABSTRACT: Among the various means of architectural research, fieldwork has customarily been a valuable data collection technique, mainly applying the methods of anthropologists to the many interpretations on the meaning of built environment. But what distinguishes architectural fieldwork from that of other disciplines today? One can also ask whether fieldwork in the discipline of architecture has responded to the general paradigm shift from structuralism to post-structuralism in academia? Further, has the concept of "global village" in the virtual reality of the World Wide Web replaced the need of one's "own village" in physical reality, as the anthropologist used to call their own study context?

The objective of this paper is to re-examine the role of fieldwork in architectural research, particularly as it relates to the qualitative paradigm and phenomenological "thick" descriptions. It also reflects possibilities in the education of research methods in architecture schools by providing methodological basis for new interpretations. As fieldwork has often been a valuable method in culture-specific studies, the paper looks at innovative research in one specific cultural milieu as an example of its applications. Cases in point are research projects conducted in Japan in which context the location of sacred or secular objects and buildings (or lack of those), as well as the ritual procession of regular Shinto festivals, reveal interesting ways of analyzing the invisible features of these built environments – or the ritual reality. Since the examples deal with interdisciplinary research, these studies embody the definition of architectural fieldwork in comparison to other multi-, cross-, or trans-disciplinary views, thereby expanding the research resources of the discipline of architecture.

KEYWORDS: Japanese urban context, Shinto festival (*Matsuri*), Activity space (*Kaiwai*), Spirit of place (*Genius Loci*)

INTRODUCTION

For many visitors, the majority of Japanese cities appear as chaotic, not the least due to the lack of systematic layout patterns, clear zoning regulations and other ordinances, or even an inclusive address system. However, this paper maintains that there is a different type of order in which invisible features are more significant than the visible ones. As these indications of a hidden order are mainly articulated by the activities taking place in the Japanese urban context, we focus on the way people experience their built environment in terms of spatial participation. Of particular significance are the Shinto festivals, called *matsuri*, and their procession that often divulge the 'activity space,' or *kaiwai*, by the participants' perception of their context, as opposing to that of a visitor. Moreover, since there is a clear correspondence between *kaiwai* and the commonly discussed Japanese space-time concept *ma*, the examples included provide insights into the meaning of spatial perception in general.

The above views of the built environment also can be regarded as means of social order, as Augustin Berque has suggested in his studies on Korean cities. In these cases, the layout functions as the expression of the structure of the society in question as well as a means of social control due to the "labyrinth" in which an "outsider" gets lost and is immediately revealed as not being an "insider" (Berque 1995). The same applies to the lack of a center, or the concept "empty center" of Japanese cities, which is famous for Roland Barthes' descriptions on Tokyo (Barthes 1982). He regards the Tokyo Imperial Palace as the "sacred nothing" in the "empty center" of the city, while Berque calls it the "forbidden forest."

This semiotic paradox, or binary opposition in Derridean terms, exposes not only the noticeable difference in the appearance of "Western" and Japanese cities, but also the value-laden and ethnocentric categorization of signs in the structural interpretations of their meaning. Whereas the former cities are typically characterized by a center marked by the culture's symbols, such as a church, a town hall, a cluster of company headquarters, and so on, the absence of any-thing in the center of a Japanese city is often interpreted as "hollowness" which disregards the plurality of meanings in the cultural framework examined below.

1.0 COSMOS vs. CHAOS

In contrast to the current layout of most Japanese cities, which appears disordered at the first glance, clear organization was fundamental in the layout of East Asian capital cities ever since the Chinese Zhou Dynasty (1027-421 BCE). This kind of centralized, grid-patterned city structure, with three concentric parts (outer city, inner city, and imperial city), refers to the *mandala* configuration, while the north-south thoroughfare of the city and the central imperial palace on it stands for the *axis mundi*; in the Chinese case, it depicts the socio-political concept of the Mandate of Heaven based on which the emperor, the Son of Heaven, ruled his subordinates as the Heaven's representative on earth. Together with Buddhism, Confucianism, and other mainland-Asian phenomena, these principles were adopted in Japan by the Asuka period (ca. 550-710 CE) and were used in the layout of all Japanese capitals from Fujiwara-kyo till Heian-kyo (today's Kyoto); this is evident even in the axial layout of the Ise shrines of the Japanese indigenous belief system discussed below, which is visible in the shrine orientation toward north after the introduction of Chinese cosmology (Nitschke 1993).¹

From the perspective of this paper, it is noteworthy that the late Heian period (794-1185 CE) was characterized by the absence of official interaction with the mainland which led to the Japanization of many cultural features. Not only did Japanese residential architecture transform from the Chinese-type, axial *shinden-zukuri* to the asymmetric layout of *shoin-zukuri*, but city planning principles changed as well. Even the layout of Kyoto did not achieve its planned axial symmetry along a north-south oriented thoroughfare and, in fact, the western part of the city was never built. On the other hand, a number of daimyos' concentric castle cities were built mainly in the Muromachi-Momoyama period (1335-1603), in which the central fortress certainly was an imposing representation of power. This culminated in the Togukawa castle in Edo (today's Tokyo, though the castle donjon does not exist anymore in the Imperial Palace grounds) that was the real political center of the shogunate, while the imperial seat in Heian-kyo lost its factual power. Also, an impressive, fortified residence, Nijo-jo Castle, was built near the Kyoto Gosho imperial palace for the Tokugawas, representing shogunal control over the imperial rule in Kyoto (Coaldrake 2002).² In other words, Kyoto remained only as a symbol of the empire, just as the emperor was only a symbolic ruler till the Meiji Restoration in 1868. Furthermore, from the beginning of the Edo period (1603-1868) a new closed doors policy prevented foreigners to enter Japan and the Japanese to travel abroad, which further contributed to the unique interpretations of the earlier transcultural influences in Japan.

As a result, typical Japanese cities do not have a perceivable center at all – neither "full" or "empty" – and even Kyoto eventually lost its intended Chinese-type orthogonal, grid-patterned, axial and symmetric layout with a centralized imperial palace. In many Japanese cases, only the location of certain religious edifices and the procession of local *matsuri* hint at specific places of significance, that is, where the festival events *take place*. Because this phenomenon can also be interpreted as *making place*, investigations on the structure of these placements and rituals reveal a hidden organization of the city or a building complex itself. Hence, the primary goal of this paper is to provide insights into new means of analysis and methods of fieldwork by looking at the spatial layering of Japanese architecture in terms of communal festival experiences and their interrelationship to the built environment. As will be shown below, these cities are far from chaotic and instead relatively ordered from the perspective of the local residents, contrary to the view of most foreigners visiting Japan. The order, and the centers, are just marked by the events, in other words, by a bricolage of temporal behavior of the community, rather than by any permanent structures.

Correspondingly, even if most visitors blame the lack of an address system for the "chaos" of Japanese urban environment as one reason, there actually is a system, just not based on street names (except for some biggest avenues). Rather than naming the lines separating the building blocks, this spatial organization is based on numbering each block in the order it was divided into plots, further sub-divided, sub-sub-divided, and so on – only a mailman, not even a taxi driver, fully comprehends it today. This is to say that the Japanese urban structure is defined by the building activity that has taken place in it, while this involvement is still depicted by various rituals meaningful for the local community.

2.0 BUILDING RITUALS

Of the innumerable Shinto festivals recurrently observed in Japan, the ones related to the ritual rebuilding of Ise Shrines every 20th year are undoubtedly the most significant in terms of a tradition that carries religious, communal and political meaning. As the main shrine is dedicated to the Sun Goddess, *Amaterasu Omikami*, the antecedent of the Japanese imperial line in the Shinto mythology, the continuation of this tradition clearly depicts national unity and communal renewal by the spatio-temporal activities of the participants. Its significance also is implied by the participation of citizens all over Japan as well as by the expenses poured into rebuilding shrines that are constructed of high-quality cypress and are still in good condition (the latest

rebuilding completed in 2013 totaled an estimate of US \$0.5 billion). This does not only include rebuilding the main shrine complexes on one of the two adjacent sites of both Naiku, the Inner Shrine, and Geku, the Outer Shrine, but also those of the ten auxiliary shrine precincts, in addition to remanufacturing the approximate two thousand artifacts and treasures housed in the shrine buildings (Bock 1974). Without delving into the many interesting phenomena of this vicennial custom, continued since the 690s, with some interruptions during wartimes, we look at the importance of social participation in these activities.

The 31 Shinto ceremonies preceding the completion of the rebuilding start seven years prior with three cutting festivals, followed by various rites, such as the log-pulling festival in which thousands of participants haul the lumber to Ise along the Isuzu River, and end by the donors from across the country bringing new white pebbles to cover the rebuilt site. Although these are all communal activities, some transfer ceremonies, in contrast, are carried out by the priests and seen only by very few privileged spectators. Among these are the rites related to the 'sacred middle pillar,' or *shin-no-mihashira*, performed by the priests in the darkness of the night. From the perspective of the meaning of invisible features of Japanese architecture, it is important to note that nobody else ever sees this pillar; in Naiku, it is buried underground, while in Geku part of it is above ground, and in both cases the pillar is covered under the floor of the main shrine building and has no structural function whatsoever. In other words, the pillar can be regarded as a representation of the *axis mundi* – invisible, yet, we know it is there (Sarvimäki 2000). Also, there is evidence that already originally some rituals were performed under the shrine hall (Nitschke 1993) and, according to Bock's account of the renewal rites in 1973, after the completion of construction "the Superintendent of the Shrines and sixty shrine priests congregated beneath the main sanctuary to perform the rite of strengthening the main central pillar" (Bock 1974, 61). Moreover, the *shin-no-mihashira* is the only part of the old shrine that is not demolished after the new shrine is completed and it stands in its shelter on the empty plot till the next rebuilding begins. There, it marks the center of the empty site even without the other structures and indicates the temporal duality of Shinto symbolism with two central pillars existing simultaneously.

Similar rituals, even if less elaborate, are involved in more mundane constructions as well, usually emphasizing the four corners and the center. Even today, most building projects start with the ground breaking ceremony (*jichinsai* or *chiniisai*), in which the area in the middle of the plot is depicted by a pole or a tree branch and a sand cone, while smaller poles or branches are located in the four corners of a square around it and connected with a *shimenawa* rope decked with *heishoku* paper-cuts. The symbolic ground breaking includes hoeing the sand cone with a ritual pick, among many other rites performed by the household head and the contractor around the altar in the enclosed area, directed by a Shinto priest. In the end, all participants visit the four corners of the site to offer rice and sake there.

The center and the four corners also are depicted in the ridge-raising ceremony (*muneageshiki*), which completes the main framework of a building. In it, the 'sacred middle pillar,' in houses called *daikoku-bashira*, is decorated with various Shinto symbols, such as white paper-cuts and a wooden plate including prayers to the *kami* (deity) who protect the family, while an altar containing offerings to the *kami* is placed on the foot of the post; in addition, the altar includes the carpenters' tools, signifying their art. Based on the fieldwork of this author, the carpenters are in an important role during the ceremony by assisting the Shinto priest in the various rites, ending in the transference of the 'corner rice cakes' (*sumi mochi*) from the altar to the four corners of the roof from where they are thrown diagonally towards the center of the house; in the ceremonies I attended, rice and sake was thrown from the ground level corners towards the center as well (Sarvimäki 2000, 199-200). Of importance, however, is that the sacred central pillar, contrary to its name, is usually not in the geometric center of a house. In most cases it is close to the hearth – in other words, the metaphorical center – regardless of its actual location in the house layout and merely indicated by elements and activities around it, not at it.

3.0 SPATIAL PARTICIPATION

In spite of the centralized feudal system of the Tokugawa shogunate with the Edo castle as its symbol, while the castle cities of local daimyo expressed their subservience to the outmost authority, most Japanese cities built in the Edo period lack visual signifiers of the government – at least in the center. Instead of a central monument or any kind of a symbol of power, the most significant buildings, such as Buddhist temples, Shinto shrines, and shogunal mausoleums, are in the perimeters of these towns. Among numerous examples, the small fishing village of Shingu in northern Kyushu sheds light onto this phenomenon. Unlike many Japanese villages and towns that grew almost organically, Shingu was planned by the feudal authorities in the 17th century, although its layout hardly appears planned from an outsider's perspective. In addition to anthropologist Arne Kalland's fieldwork descriptions on the geomantic practices in Shingu, he points out that the various Shinto festivals and location of certain objects of importance can be regarded as representing the life course of the villagers, and implicitly the structure of both the community and the town.

For instance, the Isozaki-jinja shrine in the northeast symbolizes birth with its fertility stones; this is also where the babies born in the previous year are brought for the *Hassaku* ritual in September, as well as three- and seven-year-old girls and three- and five-year-old boys for the *Shichi-go-san* ('7-5-3') festival in November. Further to the southeast there are other symbols associated with youth. Lastly, the Sainen-ji temple with the cemetery is in the west, which is the direction of Amida Buddha's paradise. Moving further clockwise around the center without anything notable there, we do not see any religious buildings in the north, until the *torii* gate leading to the Isozaki-jinja in the northeast, which starts the eternal lifecycle again (Kalland 1996).³

The both diametric and concentric structure of Shingu, evident also in the Ise shrines, is further expressed by the *Gosengu* festival that is arranged every eighteen years. It is the occasion when the center of Shingu at the crossing of a lane and Nakamachi ('middle town') Street is activated by the festival procession – otherwise there is nothing else there than an ordinary intersection (Kalland 1996).⁴ The same applies to the Kakunodate city's annual *Oyama-bayashi* festival every September of which Fred Thompson has published an elucidating fieldwork study that is particularly relevant to the argument of this paper. The procession takes place between the Shinmei-sha shrine and Yakushi-do temple, with a stop at the house of Satake, whose ancestors were the representatives of the central government in town during the Tokugawa shogunate; like Shingu, Kakunodate was replanned in the 17th century by the feudal authorities. The foci of the festivities, however, are the neighborhood altars, or *hariban*, which are constructed for every festival and demolished afterwards – in other occasions, these sites might be parking lots or other mundane spaces (Thompson 1984).

For the *Oyama-bayashi* festival in Kakunodate, one *hariban* is built in each of the distinct districts of the town called *cho-nai*, further divided into subunits. In the feudal period, the *cho-nai* system restricted mobility of the townspeople, as there were watch-gates at the boundaries of each district. Although there have been many changes in the physical and social structure of Kakunodate, and the watch-gates have long been gone, this invisible division is still preserved in people's minds, which becomes demonstrated in the *Oyama-bayashi* festival activities. Namely, every year the community re-organizes itself into the feudal teams for the festival, in which each team moves a portable shrine wagon along the streets. Their goal is to visit as many *hariban* as possible without being blocked by other teams. In this wild game of complicated rules, the teams change their status depending on whether they are approaching a *hariban* (*nobori*, 'going up') and having the way of right, or proceeding to the next *cho-nai* after having visited a *hariban* (*kudari*, 'going down') when other teams 'going up' have the way of right. After a team has crossed the invisible border between two *cho-nai*, it is in the state of *nobori* again and has the way of right. The most interesting moments happen when two teams meet at a borderline, where it is unclear who has the way of right. In other words, the invisible lines are visualized by the team members facing each other along an imaginary borderline. As both teams are halted, giving advantage to the other teams, solving the gridlock rapidly is the key to play the game successfully which requires negotiation skills and reflects social skills as well.

The whole procedure can be considered a representation of the social hierarchy and re-bonding of the communal relationships, which is also expressed by the communal eating and (excessive) drinking of sake, which are important elements of any *matsuri*. However, despite the conceptual dichotomy, it is important to note that in Shinto theology there is no separation between sacred life, known as *hare*, and secular life, or *ke*. As stated by Thompson, "*matsuri* is referred to as *hare-no-hi*, the days of *hare*. It is the time when *ke* is restored to its original state and the communion takes place through the ritual of renewal" (Thompson 1984, 15). He connects this spatial mode of social integration with the concepts *kaiwai* ('activity space') and *ma* ('space-time') by stating that "what was commonplace for the Japanese was a communal ordering of physical spaces through a variety of rituals, non-festive and festive, rather than conceptual formation of permanent monuments and civic spaces. Underlying this physical organization is the inherent quality of *ma*, which implies that, by themselves, the spaces are void, but with activity they take on forms which are meaningful to the participants" (Thompson 1984, 28).

CONCLUSION

These means of activities in the Japanese built environments represent the cyclic process of life of both the context and its people, defining cosmos from chaos by the various applications of the cosmologic conceptions. And in all of these cases, whether sacred or secular, the organization of a city or a building complex is indicated and regularly renewed by various rites and other activities. This also strengthens the communal memory, which, in turn, strengthens the meaning of the context. Usually it occurs by the concentric commotion of the partakers around the seemingly "empty" center, which bears close resemblance to the *mandala* diagram. From a phenomenological standpoint, it is apparent that rather than any built structures, the communal participation defines the *genius loci* of many Japanese urban settings.

As for methodology of the studies discussed above, all are examples of qualitative research with the researcher partaking in the activities as "a measuring instrument" (Groat and Wang 2013). Although few scholars have been as fortunate as Felicia Bock to attend the concluding Ise rites, which makes her records so valuable, the involvement of these researchers is fundamental in providing new interpretations and information on the context.

Also, because fieldwork is an integral part of these studies, including community involvement and indigenous/local cultural values and context, the studies serve as an example of a prospective non-Euro-America centralized perspective in architectural interpretations. The significance of personal experience of the context, moreover, accentuates the phenomenological thick descriptions of the spirit of place, and the role of subjectivist epistemology regarding the meaning of the built environment. Although space does not allow cross-cultural comparisons of this kind of fieldwork methodology, here, plausible is that it can be applied to other settings in analysing their meaning. Hence, while the online "global villages" might offer an interesting alternative, fieldwork in physical reality still is a valid data collection technique, although it should pursue toward new paradigms and diverse views, including the "non-verbal" features of the language of architecture.

REFERENCES

- Barthes, Roland. 1982. *Empire of Signs*. New York: Hill and Wang.
- Berque, Augustin. 1995. "The Rituals of Urbanity: Temporal forms and spatial forms in Japanese and French cities." In *Ceremony and Ritual in Japan: Religious Practices in an Industrialized Society*, edited by Jan van Breman and D. P. Martinez, 246-258. London/ New York: Routledge.
- Bock, Felicia G. 1974. "The Rites of Renewal at Ise." *Monumenta Nipponica*, Vol. 29, No. 1 (Spring 1974), 55-68.
- Coaldrake, William H. 2002. *Architecture and Authority in Japan*. London/ New York: Routledge.
- Groat, Linda and David Wang. 2013. *Architectural Research Methods* (2nd edition). Hoboken: Wiley.
- Kalland, Arne. 1996. "Geomancy and town planning in a Japanese community." *Ethnology*, Vol. 35, no. 1, Winter 1996, 17-32.
- Nitschke, Günter. 1993. *From Shinto to Ando: Studies in Architectural Anthropology in Japan*. London: Academy Edition.
- Sarvimäki, Marja. 2000. *Structures, Symbols and Meanings: Chinese and Korean Influence on Japanese Architecture*. Espoo: Helsinki University of Technology.
- Thompson, Fred. 1984 *Ritual Renewal of Space in Kakunodate and Shiraiwa*. Ontario: University of Waterloo.

ENDNOTES

¹ In the prime imperial shrines in Ise, this merge of thoughts is expressed by the "Chinese axis" and "Japanese details." For more on East Asian cosmology and its transformations in Japan, see Sarvimäki 2000.

² In addition to the many urban transformations in the layout of today's Kyoto, the original imperial palace, that would have been along the central axis had the western part of the city been realized, was abandoned after a few fires. One reason why it was not rebuilt after the last fire in the early thirteenth century might have been the lack of imperial authority. Hence, the former imperial side-palace (*Tsuchimikado-dono*) became the *de facto* imperial palace; now known as Kyoto Gosho in its mainly rebuilt condition. Coaldrake 2002: 81-93, 138-162.

³ Like in most cultures, east is associated with birth and west with death. In Japan, most weddings take place in a Shinto shrine, while funerals are arranged in a Buddhist temple and the deceased buried in its graveyard.

⁴ Here Kalland refers to Claude Lévi-Strauss' classification of two settlements patterns: (1) the diametric structure divided into two halves by an axis, and (2) the concentric structure with circles around a center.

Fusion of teaching and research: Design support tools and vegetated walls

Kenneth Black¹, James Jones¹, Mario Cortes¹, Elizabeth Grant¹

¹Virginia Tech, Blacksburg, VA

ABSTRACT: Architectural design is inherently a decision-making process, and the making of new ideas (ideation) and representation are at its foundation. Designers typically move from ideation to representation and then to multiple versions of a design (iteration). With the continued and increasing use of computers and digital representation, the design process should not become prescriptive or formulaic. Technology, such as computers, has given students many opportunities to design previously not available, for example, Adobe Photoshop, Grasshopper, and Google SketchUp. Will their method of representation be by hand, digital, or both?

At Virginia Tech, students were given a two-week project in the second-year studio and asked to use vegetated assemblies. Their work was reviewed in relation to what types of representation and methods supported their design decision making. These methods serve as an extension of the representational process and allow designers to test proposals, understand implications and allow clients to visualize work.

The purpose was to see what and how students design when using vegetated assemblies and what tools or technologies they chose to represent ideas and make decisions. This was done to confirm that the targeted programs for use in a future prototype tool were in fact the programs students used. The results from the survey statements showed that a professor's knowledge base influenced the student's comprehension and, with exposure to topics, students were more likely to include topics in future work and develop distinctive representational styles and methods.

The envisioned tool will help inform designers, but not make decisions for them. This initial research refined assumptions made about programs to target in the prototype tool, and confirmed a self-identified student need for a tool. A larger study is aimed at changing the way buildings are designed by creating a prototype tool for the representation of vegetated walls focusing on color theory.

KEYWORDS: Architecture, Design Research, Research, Student Research, Vegetated Assemblies

INTRODUCTION

This paper focuses on lessons learned from a pilot two-week project in a second-year architectural design studio with a view toward the future creation of a prototype tool to aid the design of vegetated walls. This two-week project provided insight for a future larger and longer studio and a new design support process, which will provide a framework to help novice students and designers to make decisions. The students targeted for the subsequent semester-long studio will most likely be fourth-year students. These fourth year students will help to determine how designers (students) currently address the process of representation and decision-making as it relates to vegetated assemblies. From this understanding of the current process employed by students, a framework for a design support process (DSP) will be created with the intent of developing a prototype tool. The prototype tool would be a computer program to help in the representation of vegetated assemblies, most likely in the form of a computer program combined with cross-checking databases. After the development of the DSP, a second studio with fourth-year students will be implemented to include the use of the DSP and the prototype tool. This second studio will serve to validate both the DSP and the corresponding prototype tool for vegetated wall systems as students employ it in their design work.

1.0 BACKGROUND

1.1. Areas of inquiry for the new prototype tool

The study has four main concepts: aesthetics, decision theory, color theory, and plant biology. This study will engage aesthetics from a phenomenological view. This philosophical view is concerned with the study of consciousness from personal observations. The critical experience of phenomena is in considering the content or meaning given to an object in light of our own notions and thinking.

First, aesthetics can be defined as a strain of philosophy dealing with the nature of beauty, and encompassing questions of, for example, proportion or composition. However, there are many different kinds of interpretations of aesthetic beauty. Immanuel Kant believed aesthetics to be a subjective experience of beauty, universal in function only when disinterested (Kant and Walker 2008). To Friedrich Schiller, aesthetic appreciation of beauty was the most perfect reconciliation of the sensual and rational parts of human nature (Schiller and Snell 2004). As expected, methods of thinking or expression that are subjective in nature, such as architectural design, have many different aesthetic definitions or processes.

Second, decision theory or decision-making theory is centered on the processes and steps that go into determining proper choices, based on a series of criteria. Decision theory resides in situations where one is making a decision in response to a problem without a clear, single answer (Hansson 2005). While this definition of decision theory is more general, there are specific constructs or methods related to design, including design support structures (DSS) and decision support processes (DSP). These structures are less about making the final decision for the designer and more about supplying the designer with information with which to make an informed decision (Cross 2007, 2011). The experience of the designer helps him or her to use the DSP to design more effectively. The design support structure that will become the prototype representation tool in this research will help designers make decisions, but not make decisions for them.

Finally, color theory, according to Goethe, is a guide to the nature of colors and how these colors are perceived by humans (Steiner, Goethe, and Barnes 2000). His understanding of color centered on how the phenomena of color are perceived and was less concerned with analytic properties. However, this is only one view of color theory and this concept is interpreted in many ways. Color theory in this study is used as one of the criteria for selecting plants in the future framework and prototype tool. Color in plant biology can influence the appearance and representation of a vegetated assembly over the course of the seasons.

Plant biology, also called botany or plant science, is the scientific study of plants, including their physiology, structure, genetics, ecology, distribution, classification, and economic importance. Plant biology is useful in determining plant species since vegetated walls use plants as a main component and their color can vary widely. This research engages questions students may have, but not know where to find answers to, such as: What kinds of plants are adaptable to vegetated assemblies in the southwestern Virginia climate zone?; Are there compatibility issues between types of plants selected in assemblies?; and What are possible implementation issues for plants that are adaptable in vegetated walls?

But beyond this, this study begins to investigate reasons why people find plants and nature desirable. According to Edward O. Wilson, this desire, called biophilia, is an appreciation of life and the living world (Kellert and Wilson 1993). The research aims to discover how plant biology and the practicalities of incorporating vegetation on the envelope of a building can be combined with color theory in the design of vegetated building assemblies.

2.0 METHODOLOGY

2.1. The as-is process in studio and the studio prompt

In this preliminary study, a group of students were given a two-week project in a second year studio with the requirement to use vegetated assemblies. Their work was reviewed in relation to what types of design representation and methods were chosen and how they were used in support of their design decision-making process, which was termed the “as-is” process. The purpose of the current study was to see not only what the students designed when using vegetated assemblies, but how they designed. The study documented the tools and technologies the students chose to represent their ideas and to help them to make decisions. This was done to determine whether or not the targeted or anticipated programs planned to accept 3D models in the new prototype tool were in fact the programs students or would use.

This first project used the teaching method of the second year studio and a two-week project module to determine how students interacted with a project based on previous experiences. The studio used a series of two-week projects to keep the students in an iterative mindset and to make decisions about projects quickly, within the constraints provided by the brief and site. This project was a learning experience for the lead author, as he was the teaching assistant, and the professor, Mario Cortes, reviewed and approved the project. It was important to take out the uncertainty of teaching experience as much as possible to limit its effect on the students during later and larger implementations of the new studio frameworks and the use and revisions of the prototype tool. The following was the studio prompt for the two-week project involving an amphitheater near the Duck-pond on Virginia Tech’s campus. The project was designed to get the students

thinking about a larger site context rather than a singular location when implementing vegetated facades. The prompt given to the students read as follows.

This project seeks to explore the boundaries between nature and its application in architecture. This project will serve as an exploration into what a vegetated wall can be when designing an amphitheater at Virginia Tech in the context of a specific site. The project is located near the president's house up the hill from the duck pond, across the road from Hillcrest Hall on the site of the old WPA amphitheater. In the project it would be ideal to be able to explain its sense of place, so please visit the site when reacting to its conditions. It is under the tree cover at the site. This project has the opportunity to serve as a place to entertain and showcase performance arts such as theatre and cinema. Treat the project as an extension of the surrounding area, including the President's ability to entertain guests.

Some important things to consider are issues of sustainability, vegetated walls, and water recycling for the living wall and amphitheater intervention. The project interventions can be made of any materials. Finally, each student will also maintain a work journal that describes their process and evaluation of the studio and professor. This is essentially a word document that shows what you did each day, how you did it, and your thoughts on the teaching method (expectations and results). Please keep track of all you work as you will need to turn in a digital copy of the work in the form of a portfolio page presented at the end of the project period.

Figure 1: Prompt for the studio to the students

2.2. Reviewing the as-is process after project completion

After the completion of the vegetated wall and amphitheater studio project, a survey was given to the students in an attempt to discover their desire or need for a design tool, and how this related to the expertise of the individual. The survey included the following questions and statements.

- 03: Have you used vegetated assemblies in a project before?
- 04: What kind of drawing techniques did you use? (You can select digital and/or hand-drawn)
- 05: What kinds of techniques did you use during the project?
- 06: What kinds of pens or pencils or paper for hand-drawing, or what programs for computers?
- 07: I understand the considerations involved in designing vegetated assemblies.
- 08: A design tool for vegetated assemblies would be helpful in your design process.
- 09: Architects provide valuable insight to vegetated assembly design.
- 10: I understand the benefits and qualities of installing vegetated assemblies.
- 11: I understand how I can design vegetated assemblies in studio.
- 12: Building users provide valuable insight into the design of vegetated assemblies.
- 13: I understand the risks and complication to design when including vegetated assemblies.
- 14a: I have familiarized myself with other projects that used vegetated assemblies for the project.
- 14b: What were some of the projects?
- 15: I know the general types of vegetation that will thrive on a vegetated wall.
- 16: I know the general types of vegetation that will thrive on a vegetated roof.
- 17: I know the general types of vegetation that will thrive on a vegetated facade.
- 18: I understand the difference between the various types of vegetated assemblies.
- 19: I understand the major obstacles to implementing vegetated assemblies.
- 20: Vegetated assembly suppliers provide valuable insight into vegetated assembly design.

From this initial exploration of the process undertaken by each student to design their project, the new prototype tool can reflect the nature of the design process. This future tool will be introduced back into a studio environment to see how the design process was influenced and assisted by the addition of the tool.

3.0 RESULTS

3.1. Results of the as-is process survey

As shown in Table 1, which addresses questions 3 through 6, many in the studio did not have prior experience with vegetated walls and other assemblies. Of the 12 students who responded, 7 self-identified as working in both analog and digital techniques, often switching between techniques to explore designs. Students who worked with hand-drawn techniques worked with media such as charcoal on brown paper, pencils, pens (mainly HB lead and micron pens) colored pencils, and Prisma markers. Students who worked with computers used programs such as Rhinoceros, Photoshop, Illustrator, Google SketchUp and InDesign. Figures 2 through 4 show the range of media used in the design studio.

Table 1: Number of students in relation to experience and method used in vegetated assemblies

Experience and Method	Digital/ Computer Design	Analog / Hand-Drawn	Both Digital and Hand-Drawn
No Previous Experience with Vegetated Assemblies	2	2	6
Previous Experience with Vegetated Assemblies	1	0	1

This confirms what was suspected: there was a range of personal preference when using techniques to explore designs, in this instance, over half (7 of 12) of the students used both methods. It was also found from the responses gathered that the list of assumed computer programs used by students should be expanded. For example, the framework and the prototype tool would need to be able to take scanned images as well as exported files from Rhinoceros, Photoshop, Illustrator, and Google SketchUp for use in the tool. Illustrator was a program that had been overlooked initially, but will also be included as it is the vector-based version of the Adobe software often used in conjunction with Adobe Photoshop. Adobe InDesign was mainly used to design layout of presentation materials for the projects, rather than design development. Having confirmed what kinds of methods would be useful for interfacing with the prototype tool, the next step was to confirm that the students are interested in using such a tool. Before the project half (6 of 12) agreed that a prototype tool would have been helpful, after the project, 83% agreed (10 of 12).

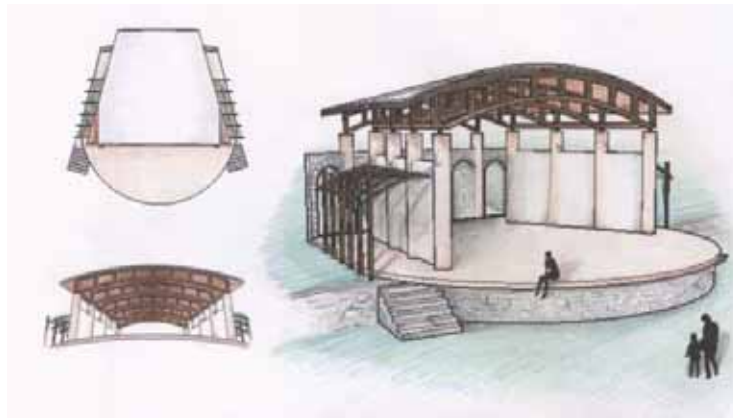

Figure 2: One student's amphitheater, using hand renderings of a google sketchup computer model

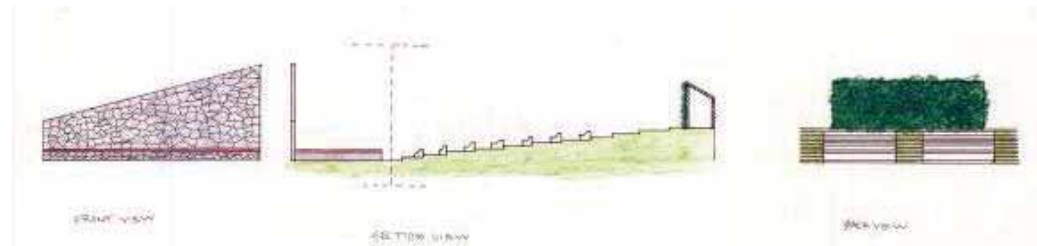

Figure 3: Another student's amphitheater, hand drawn and hand rendered



Figure 4.1: A third student's amphitheater, digitally rendered in google sketchup

The students were asked to keep a journal or sketchbook as a record of their initial design process and thoughts on the project. One of the topics that showed up consistently were notes on the site conditions and initial impressions of the space framed at the site and how this would be incorporated into their design process. Some examples were: the wind through the trees, sunlight shimmering in the leaves, either developing a sense of seclusion or invitation, amplifying sounds, or using the topography. The images below are from the sketchbook of the same student who proposed the space in figure 4.1, above. This particular student explored both of the categories (hand drawn and computer-aided) during the project period.

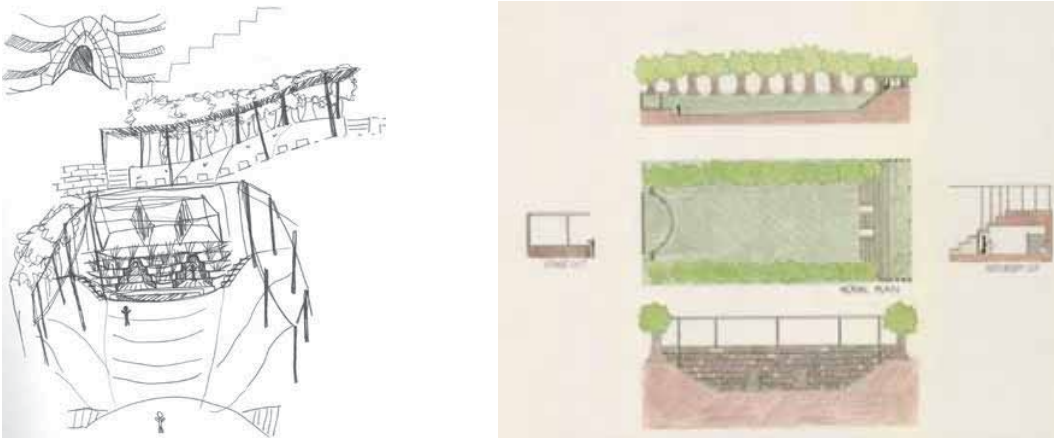

Figure 4.2, 4.3: Sketchbook to hand-drawn constructed drawings, then the computer rendering in figure 4.1.

The students made a number of interesting responses to the survey. Some selected responses are shown in figure 5, and explained in detail below. The remaining questions are shown in comparison in figure 6. From the set of questions and statements listed previously, six will be reviewed here in more depth:

- 07: I understand the considerations involved in designing vegetated assemblies.
- 11: I understand how I can design vegetated assemblies in studio.
- 13: I understand the risks and complication to design when including vegetated assemblies.
- 14a: I have familiarized myself with other projects that used vegetated assemblies for the project.
- 18: I understand the difference between the various types of vegetated assemblies.
- 19: I understand the major obstacles to implementing vegetated assemblies.

A "post-then-pre assessment" was used to compare students' opinions after completing the project to their opinions before beginning it. For each of these six statements, students were asked to rate on a Likert scale of strongly disagree to strongly agree, their level of agreement with the statement after the project was

completed, and to also estimate their agreement with the same statement before beginning the project. Results are shown in Figure 5 out of 12 student responses per statement.

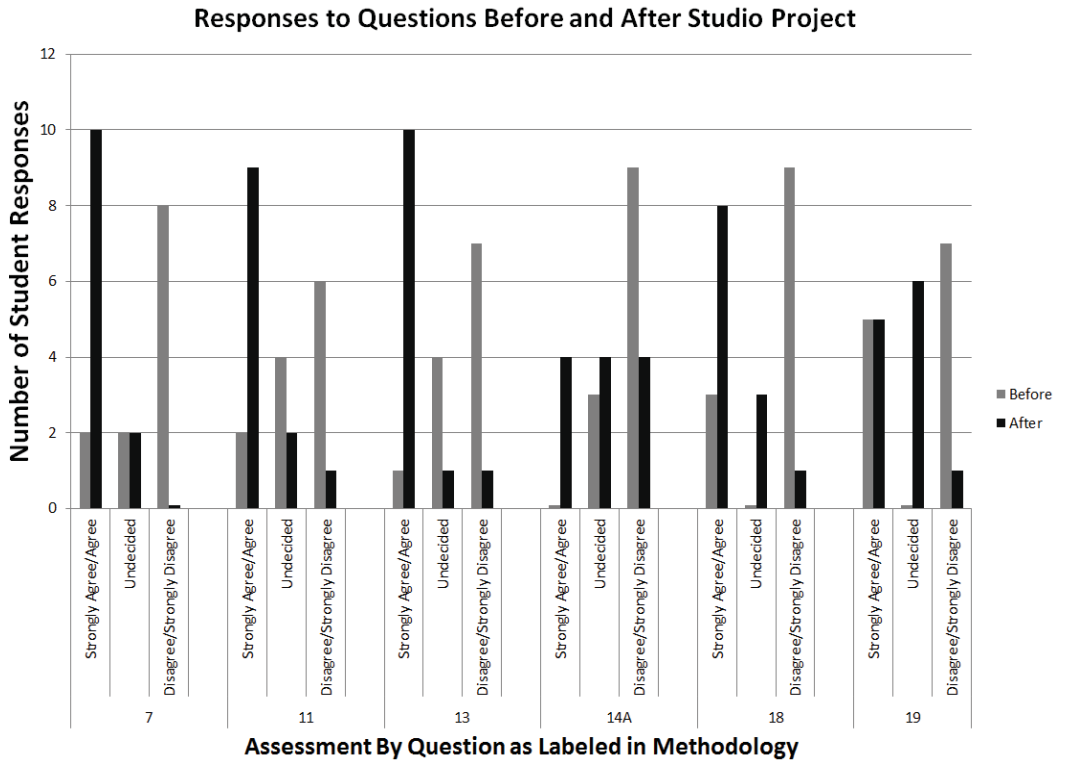

Figure 5: Selected responses to questions before and after studio project

In statement 7, the students responded that they had a greater understanding of the considerations involved in designing vegetated assemblies after the project. In statement 11, they expressed a greater understanding after the project as to how to design vegetated assemblies. In statement 13, they showed that after designing a vegetated wall, they now understood the risks and complications involved with the design when including vegetated assemblies. What was most interesting was the response to statement 14a: “I have familiarized myself with other projects that used vegetated assemblies for the project”. The students were not familiar with vegetated projects before the studio, but not all of them indicated that they had looked at precedents even after the two-week studio project. While vegetated assemblies were discussed as a building system by the teaching assistant leading the project, specific projects were not used as examples, in an effort to see whether students would search for precedents on their own. Knowing that not all students have the inclination or means to discover precedents on their own will be critical to developing the future prototype tool. In responses to statement 18, they understood the differences between the different types of vegetated assemblies after the studio project. In statement 19, the same number of people agreed with understanding obstacles to implementing vegetated assemblies both before and after the project, but many were undecided, which suggests that this was another place to target in the prototype tool.

Figure 6 shows the remaining responses which were for the following questions:

- 08: A design tool for vegetated assemblies would be helpful in your design process.
- 09: Architects provide valuable insight to vegetated assembly design.
- 10: I understand the benefits and qualities of installing vegetated assemblies.
- 12: Building users provide valuable insight into the design of vegetated assemblies.
- 15: I know the general types of vegetation that will thrive on a vegetated wall.
- 16: I know the general types of vegetation that will thrive on a vegetated roof.
- 17: I know the general types of vegetation that will thrive on a vegetated facade.
- 20: Vegetated assembly suppliers provide valuable insight into vegetated assembly design.

Responses to Questions Before and After Studio Project

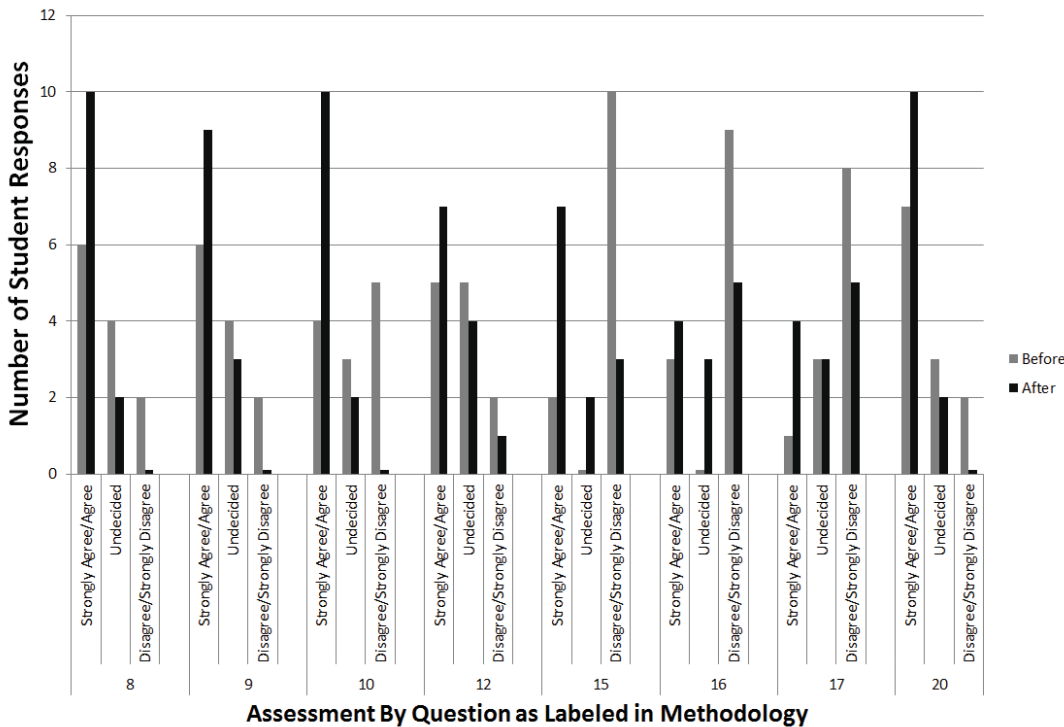

Figure 6: Remaining responses to questions before and after studio project

4.0 DISCUSSION

4.1. The To-Be Model in relation to the As-Is Interpretation

From these results in the survey, the method for exploring the new prototype tool was diagrammed from ideation to the tool. This served as the initial mapping of decisions that would be used in formulating the tool.

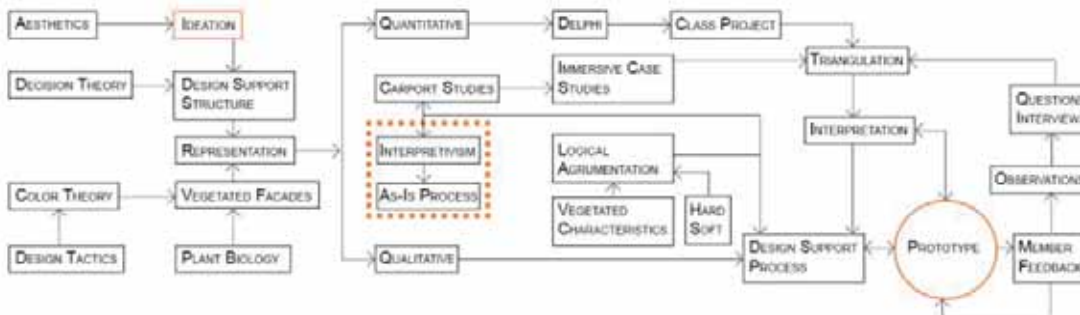

Figure 7: Theory map for the prototype tool methodology; the dotted rectangle shows the work of this study

The project brief using the design of an amphitheater to guide students into understanding vegetated walls was beneficial. Looking at the questions from the survey, students have a greater understanding of vegetated assemblies after having completed the design process, but still lack some major components necessary to the design of such assemblies. These include a greater understanding of plant biology and its interaction with color, where descriptions of cultivated species can be found from growers; and the obstacles of implementing vegetated assemblies in design. While some information was lacking in the survey, it provided the basis for solidifying the framework for a decision support process, and identified a need for

features that will be critical for a prototype tool, such as lists of growers, precedent studies, and color theory representations. By understanding the aesthetic characteristics and representations of vegetated assemblies, a future design support tool will integrate aesthetic design with vegetated assemblies through synthesizing vegetation/plant growth, color theory, and design decision-making in a prototype tool.

CONCLUSIONS

This study was the first stage of a research agenda to discover the characteristics of vegetated elements in architectural design in reference to color theory and plant biology. Among other questions, designers need to consider what kinds of plants are adaptable to vegetated assemblies. They need to consider compatibility issues between types of plants selected. Finally, they need to consider possible implementation issues for plants that are adaptable in vegetated walls, such as watering, pollination, or root depth.

From the two-week pilot studio project, several observations can be made. While all of the students had the same project and parameters, a wide variety of responses were designed. The investigation into the representational styles of students in their second year of development is also important. While this project represented only the fourth architectural project in these students' academic studies as architecture students, they already had developed distinctive representational styles and methods that students employ will change and develop further. Another purpose of this study is to determine at what point in a student's development a decision support process and/or a prototype tool would be the most helpful.

The results from the survey statements show us that the professor provides a large amount of information and control in the understanding and comprehension of topics, in this case vegetated assemblies. To specifically address areas where the students reported a lack of understanding or knowledge, the prototype tool should include information that can provide examples of precedent projects as reference, a list of possible suppliers, a list of plants useable in the project's climate zones, as well as demonstrations of possible means of representing the vegetated assemblies that they design. For example, in their responses to statements 15 through 17, after the project, students knew more about vegetated walls, but relatively less about vegetated roofs, suggesting that without specific instruction about vegetated walls, the students would have understood them in a similar manner to vegetated roofs. Since this is the first author's personal specialization, this also suggests that the teaching and research that either a professor or a professor and students do together can greatly influence the interest of students in particular topics from exposure to new information. Using the information presented by the prototype tool, the professor and the student/designer can then analyze proposed designs in light of the real constraints of vegetated systems.

CONTINUATION

This study was the beginning of a much larger study into the representation of vegetated assemblies. By confirming what methods and programs students use for representing vegetated assemblies, we can begin to target these programs for use with the future prototype tool for design support. If the students are familiar with programs and the prototype tool in their formal education, then these programs and methods can be used to conduct research into not only vegetated assemblies, but other aspects of architecture throughout their careers. The ultimate goal of this longer study is to determine a useful prototype tool for the future conductors of design research: our students. Finally, the software used by students in this pilot study will be reviewed in both academic and professional settings for use in the prototype tool.

ACKNOWLEDGEMENTS

We would like to thank the students for working with us to explore these concepts, and the work they provided are invaluable to understanding the architectural design process that fuses research with studio.

REFERENCES

- Cross, Nigel. 2007. *Designerly ways of knowing*. 1st ed. Boston, MA: Birkhauser.
- Cross, Nigel. 2011. *Design thinking : understanding how designers think and work*. Oxford ; New York: Berg.
- Hansson, Sven Ove. 2005. *Decision Theory: A brief introduction*. Stockholm: Royal Institute of Technology (KTH).
- Kant, Immanuel, and Nicholas Walker. 2008. *Critique of judgement, Oxford world's classics*. Oxford ; New York: Oxford University Press.
- Kellert, Stephen R., and Edward O. Wilson. 1993. *The Biophilia hypothesis*. Washington, D.C.: Island Press.
- Schiller, Friedrich, and Reginald Snell. 2004. *On the aesthetic education of man*. Mineola, N.Y.: Dover Publications.
- Steiner, Rudolf, Johann Wolfgang von Goethe, and John Barnes. 2000. *Nature's open secret : introductions to Goethe's scientific works, Classics in anthroposophy*. Hudson, NY: Anthroposophic Press.

Integrating architectural research within interdisciplinary global studies

Phoebe Crisman¹

¹University of Virginia, Charlottesville, VA

ABSTRACT: Research in the built environment is moving in new directions, yet architectural discourse regarding interdisciplinary research typically focuses on how other disciplines can inform architecture. This paper examines the value of the reverse process. Where can innovative architectural research *enter within* interdisciplinary programs and research *outside* the architecture discipline and profession? At a time when many universities are creating Global Studies programs, one wonders why the concepts, research, and practices of architecture are excluded. Certainly the design of human settlement is central to many of the supranational phenomena examined in global studies research, such as climate change, rapid urbanization, disaster relief and development, human health, and sustainability broadly conceived.

This paper develops a case study based on two years of participant-observation research analyzing a new interdisciplinary major in Global Studies at the University of Virginia. A complex partnership between the College of Arts & Sciences and the Schools of Architecture, Commerce, Education, Engineering, Leadership and Public Policy, and Nursing, the program structures research and courses around broad skills and methods of understanding global phenomena. Outcomes include both substantive knowledge and enduring life-enhancing skills. While Public Health, Development Studies, and Security and Justice were originally planned concentrations for the major, serious consideration of the built environment was absent. As a Professor of Architecture, I worked to integrate environmental issues within the proposed major through a Global Environments and Sustainability concentration. The architectural discipline's knowledge and research methods, such as design thinking, participatory and practice-led research and experiential learning methods, can effectively contribute to a focus on creating innovative solutions to real-world environmental, social, and economic challenges. The Global Environments + Sustainability approach establishes a translatable model to bring research in sustainable architecture and environmental design to the forefront of Global Studies.

KEYWORDS: Global Studies, Architecture, Sustainability, Interdisciplinary Research

INTRODUCTION

As noted by the Architectural Research Centers Consortium conference conveners, "Research in architecture, design and the built environment is currently diversifying and reaching new directions. Technological changes, such as new materials, construction techniques and design representations, have accelerated the need for research within design disciplines" (ARCC 2015). Yet architectural discourse regarding interdisciplinary research typically focuses on how other disciplines, particularly the hard, applied and social sciences of computation, engineering, materials science, biology, and cognitive psychology, can inform architecture. The humanities contribute philosophy and critical theory to the mix. It seems that the architectural discipline is unsure of what knowledge, research methods and pedagogical approaches we have to offer those *outside*. This paper examines the value of the reverse process. Where can innovative architectural research *enter within* interdisciplinary programs and research *outside* the architecture academy and profession? Global Studies offers a significant new territory for architectural research.

1.0 RETHINKING GLOBAL STUDIES

This case study aims to help others create integrative research agendas and interdisciplinary approaches and programs that are particularly crucial in the current university environment. Many of today's most pressing issues are too complex for one discipline, grants increasingly require interdisciplinary teams, and student demand for interdisciplinary programs is ever growing. Design thinking and data visualization are two areas, for instance, where the architectural discipline is influencing other areas of knowledge. At a time when universities around the world are creating interdisciplinary Global Studies programs, one wonders why the concepts, research, courses and practices in architecture and the built environment are rarely included in the mix.

1.1. Why global studies and architecture?

Since the 1990's there have been an increasing number of academic conferences, associations, research publications, and university degree programs focused on global studies. There are several reasons for this development. As noted in a recent overview of the history of Global Studies:

The emergence of Global Studies as a distinct interdisciplinary field occurred at a time when globalization was increasingly and profoundly affecting multiple areas of people's everyday lives. Scholars and students have found that Global Studies enhances our understanding of global phenomena by bringing the methodologies and discourses from a variety of disciplines to bear on many of the most pressing issues of our day. Global Studies makes connections not only among various disciplines but also between the local and the global, and oneself and others (Campbell 2010, xviii).

As would be expected in an interdisciplinary field, the scope of global studies varies considerably between institutions. For instance, the Global Studies Association was established to address "the vast social, political & economic transformations of global scope which are impacting upon the world today" (GSA 2014). Note that environmental transformations are missing from the mission statement. A few recent textbooks, such as *The Globalization Reader* and *An Introduction to Global Studies* do include chapters on "Global Environmentalism" (Lechner 2012) or "The Natural Environment" (Campbell 2010), however, they tend to undervalue the designed transformations of the built environment.

There is a very different way to think about the scope of Global Studies. As stated in a 2014 report prepared by the University of Virginia's Global Curriculum Committee:

The GS curriculum aims to foster creative thinking about complex global challenges that cross borders by drawing on the substantive knowledge of multiple disciplines and by equipping students with analytic tools, language expertise, and cross-cultural insight, thereby enhancing their understanding and ability to work and lead in an interconnected world" (UVA 2014, 4).

Certainly the design of human settlement is central to many of the supranational phenomena examined in global studies research, such as global climate change, movements of people and rapid urbanization, disaster relief and development, human health, and sustainability broadly conceived. Is architecture excluded because the physical world is often undervalued in the humanities disciplines that typically form the core of global studies: politics, history and economics? Deep divisions between environmental science and environmental design departments often prevent a more holistic environmental understanding that thereby limits productive research and teaching opportunities. The knowledge and research methods of the architectural discipline have much to contribute and to gain from this effort. For instance, few of the liberal arts disciplines incorporate participatory research, design research, or experiential learning methods that are particularly important given the focus on establishing community partnerships to create innovative solutions to local environmental, social, and economic issues. By examining a conception of Global Studies that incorporates architecture as a crucial area of research and study, this paper aims to develop a translatable model for Global Studies.

1.2. A case study: global studies at the University of Virginia

Faculty in a diverse range of disciplines at the University of Virginia were conducting research and teaching about *the global* and globalization, yet a formal program in Global Studies was not established until April 2014. A Global Curriculum Committee was appointed by the Provost during the 2012-13 academic year to study the value and viability of Global Studies at the University. The Committee's final report was submitted in April 2013 and recommended creating a new Global Studies undergraduate major with six concentrations. Graduate programs and research faculty hires were to follow. The program was conceived as a complex partnership of numerous academic units, including Arts & Sciences, Architecture, Commerce, Education, Engineering, Leadership and Public Policy, and Nursing (Fig. 1). As articulated in the final Committee report, "A major in Global Studies will allow students to draw on the best from across the University to prepare for the 21st century world where cultures, ideas, histories, vulnerabilities, environments, and human needs are increasingly interconnected" (UVA 2014, 3). Moving forward with Global Studies required the commitment of a wide range of University stakeholders, including the President, Faculty Senate, Schools, Departments and individual faculty members and students. During her Fall 2013 Welcome Address, University of Virginia President Sullivan noted the importance of "the ability to think with a global comparative perspective and to thrive in an interconnected world of diverse cultures...we will create a Global Studies curriculum that allows students to address global challenges such as health, development, and sustainability in their academic studies" (UVA 2014, 4). A Global Studies Operational Committee worked during the 2013-14 academic year to refine the proposal for review and University approval.

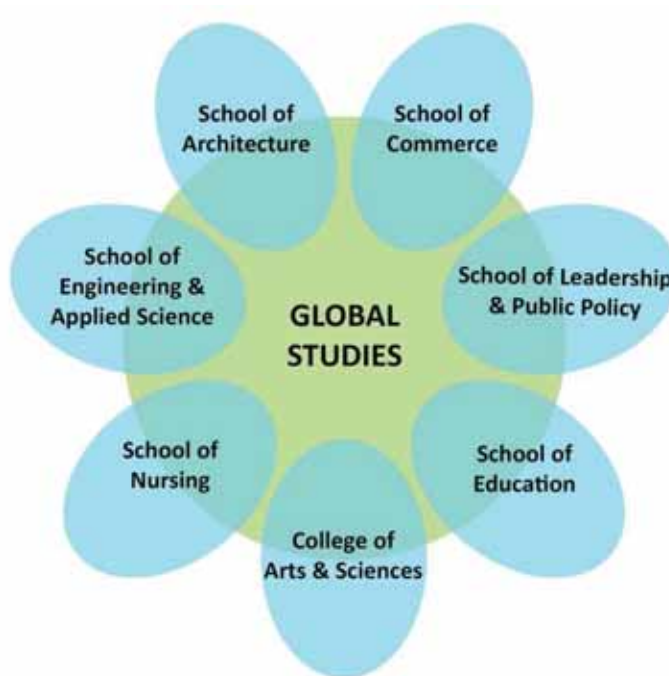

Figure 1: Global Studies as a Partnership of Academic Units at the University of Virginia.

Throughout the planning process the most debatable issues were overall program scope, disciplinary involvement, and the particular concentrations or tracks that would comprise the major. Writing about the range of interdisciplinary programs at the University, Anthropology Professor Richard Handler noted: “...what distinguishes all these [interdisciplinary studies] programs from disciplinary majors is not their interdisciplinarity but their interstitial institutional position” (Handler 2013, 195). There are many uncertainties and associated opportunities for a major outside the traditional disciplinary departmental structure, where funding and political power is consolidated at most universities. Discussions about which disciplines and departments should be involved and the specific titles of the tracks were contentious at times. As the School of Architecture representative on both committees over the two-year development period, I advocated for the important role of both the *natural* and *constructed* physical environment in global studies. Sustainability was the primary concept that joined faculty research in the physical sciences and the built environment. These issues were not initially acknowledged in committee discussions. Building on a successful interdisciplinary Minor in Global Sustainability initiated and offered by the School of Architecture, I argued for and developed a concentration in Global Environments and Sustainability to be included in the major. That track was ultimately approved long with three others: Global Public Health, Global Development Studies, and Global Security and Justice (Fig. 2). Together the interdisciplinary major and minor programs bring research in sustainable environments and architecture to the forefront of global initiatives at the University of Virginia.

1.3. Global environments + sustainability

The Global Environments and Sustainability (GSVS) track addresses problems associated with human transformations of the earth through the triple lens of environment, equity and economy. The relationship between human societies and the planet have created many of today’s most intractable global challenges. A key characteristic of these problems is their multidisciplinary scope and scale, encompassing not only technical issues, but also historical, social, political, ethical, environmental, economic and aesthetic ones. Students develop knowledge and skills for the study and sustainable transformation of the physical environment. Along with four required Global Studies core courses, the concentration begins with a project-based foundation course entitled *Global Sustainability*. Students work in teams to realize a *Think Global / Act Local* project with campus and community partners. Together they create innovative solutions to local environmental, social, and economic challenges. Students select five courses from an approved course list distributed in environment, equity and economy areas. The figure below depicts the GSVS curricular structure and course offerings (Fig. 3). Foreign language and global experience co-requisites complement core classes. Along with educating about the many facets of sustainability, the Global Studies major is

designed to empower students to accomplish positive change through a senior Capstone project completed under the guidance of faculty advisors from different disciplines.



Figure 2: Structure of the interdisciplinary Global Studies Major at the University of Virginia.

2.0 ARCHITECTURE WITHIN GLOBAL STUDIES

How are architectural knowledge and research methods valuable *within* global studies? Climate change, sea level rise, rapid urbanization, disaster relief and development, human health, sustainability and other supranational phenomena examined in global studies research are all connected to how we physically inhabit the planet. The way that architects approach problems using design thinking, speculative research and participatory design can greatly contribute to a Global Studies program focused on creating innovative solutions to real-world environmental, social and economic challenges.

2.1. Beyond critical thinking

In his essay, “Beyond Critical Thinking,” Michael S. Roth examined the limitations of critical thinking and its potential negativity in the humanities. As an intellectual historian and president of Wesleyan University, Roth is interested in teaching students “how to engage in the practice of exploring objects, norms and values that inform diverse cultures. In doing so, students will develop the ability to add value to (and not merely criticize values in) whatever organizations in which they participate” (Roth 2010). Adding value requires speculative and innovative thinking beyond mere critique. Several humanities disciplines involved in global studies practice a critical thinking approach that often does not lead to creative problem solving. The *design thinking* (Rowe 1987) and *systems thinking* (Meadows 2008) approaches that predominate in the architecture discipline can be introduced into Global Studies to open possibilities as both students and faculty confront *wicked problems* of global scope. Project-based learning, while not a common pedagogical approach in the humanities, may be successfully translated from architecture as well.

GLOBAL SUSTAINABILITY: Required Foundation Course				
<p>EQUITY elective</p> <ul style="list-style-type: none"> Global Culture and Public Health Social and Cultural Anthropology Emergence of States and Cities Disease, Epidemics and Society Human Impact on Environment Economic Anthropology Class Race & the Environment Buddhist Approach to Development Global Environmental Media Animals and Ethics Collaborative Sustainability Planning Community Food Systems Environmental Ethics Global Ethics Global Ethics and Climate Change Religion, Ethics & the Environment Sociology of Development Sociology of Consumption Globalization & Social Responsibility Sociology of Globalization Global Environmental History 	<p>ECONOMY elective</p> <ul style="list-style-type: none"> Desire and World Economics Environmental and Public Health Managing Sustainable Development Investing in a Sustainable Future Development Practice Local Solutions / Global Challenges Environmental Economics Ecological Economics Environmental Decisions Climate Change: Science, Markets & Policy Food in a Changing World Commerce, Culture & Consumption in World History Planning & the Non-Profit Sector Law, Land, and the Environment Land Use and Growth Management Healthy Communities Environmental Policy & Planning Politics of Food Natural Resources Policy 	<p>ENVIRONMENT elective</p> <ul style="list-style-type: none"> Ecology and Society: An Intro to the New Ecological Anthropology People, Culture, and Environment of Southern Africa The Nature of Nature Systems, Sites, and Buildings Models for Higher Density Housing Energy Performance Workshop Intro to Green Engineering Intro to Environmental Engineering Water for the World Water Resources Engineering Coastal Engineering: Energy & Environment Public Transportation Green Engineering Sustainable Energy Global Technology Practice Building Energy Systems 	<p>ENVIRONMENT elective</p> <ul style="list-style-type: none"> The Inconvenient Truth: Climate, You and CO2 Conservation Ecology: Biodiversity and Beyond Beaches, Coasts, and Rivers Fundamentals of Ecology Earth processes as Natural Hazards Topics in Oceanography Geology & Ecology in US National Parks Global Coastal Change Seminar in Environmental and Biological Conservation Restoration Ecology Limnology: Inland Water Ecosystems Ecosystem Ecology The Theory & Practice of Biodiversity Conservation Water Quality & Contamination 	<p>ENVIRONMENT elective</p> <ul style="list-style-type: none"> Healing Spaces Cultural Landscapes Planted Systems & Urban Ecology Green Cities/Green Sites Transportation and Land Use Cities + Nature Housing & Community Development Degrowth Global Climate Change Sustainability and Adaptive Infrastructure Water Sustainability Sustainable Energy and Megacities Infrastructure & Development Earth Systems Technologies and Management Development on the Ground
<p>CO-REQUISITES: Foreign Language + Global Experience requirement</p>				
<p>GSVS CAPSTONE SEMINAR: required for 4th year students</p>				

Figure 3: Global Environments and Sustainability Curriculum.

2.2. Design research

From amongst the many accepted architectural research strategies (Groat 2013),¹ design research has a distinct contribution to make in Global Studies. Design research has been theorized in slightly different ways using terminology such as practice-led research, performative research, and research by design. Whatever the nomenclature, practice-led research differs from problem-led research that always begins with a problem to be solved. “This is not to say these [practice-led] researchers work without larger agendas or emancipatory aspirations, but they eschew the constraints of narrow problem setting and rigid methodological requirements at the outset of a project” (Haseman 2006, 4). Often this type of research includes community participants and/or experiential learning methods. As a complement to other research methods in Global Studies that often focus on global policies or top-down strategies, starting with local conditions can lead to radically different proposals—many of which may be replicable or translatable to very different locales.

2.3. Agency

Most Global Studies faculty and students want to do more than analyze and understand global challenges. They want to act. This desire for individual and collective agency is particularly strong around pressing sustainability challenges. “Agent of change” is one of the most popular phrases on college campuses today, while student organizations seeking to bring about intentional change have dramatically grown in number, scope and effectiveness. Arguments for human agency in Global Studies can be supported several theories, including Bruno Latour’s actor-network theory (Latour 1987) and Anthony Giddens’s structuration theory.

[Agency] means being able to intervene in the world, or to refrain from such intervention, with the effect of influencing a specific process or state of affairs. This presumes that to be an agent is to be able to deploy a range of causal powers, including that of influencing those deployed by others. Action depends on the capability of the individual to “make a difference” to a pre-existing state of affairs or course of events. An agent ceases to be such if he or she loses the capability to “make a difference”, that is to exercise some sort of power (Giddens 1984, 14).

Along with this concept of human agency, and by questioning the privileging of subjectivity and consciousness so prevalent in the humanities, the significance of the physical world and the reengagement with everyday material realities can also be embraced. The “new materialism” of Manuel DeLanda (and

Jane Bennett's sustainability-focused theory of "thing-power materialism" foster a "greater recognition of the agential powers of natural and artifactual things, greater awareness of the dense web of their connections with each other and with human bodies, and finally, a more cautious, intelligent approach to our interventions in that ecology" (Bennett 2010). Building on the work of Spinoza and Deleuze, Bennett's argument for the power of inanimate things to interact with other things to produce effects helps to explain the crucial role for the design disciplines in Global Studies.

CONCLUSION

Architecture's concepts, research methods and practices have much to contribute *within* interdisciplinary programs and research *outside* the architecture discipline and profession. The interdisciplinary Global Studies Major at the University of Virginia is a compelling example of how research in sustainable environments and architecture is brought to the forefront of Global Studies. This case study examined the intentions and process of creating the Global Studies program and the Global Environments and Sustainability concentration. An evaluation of the implemented program itself will have to wait for the first class of graduates in 2016 as the program develops over time (Fig. 4). The next phase of this research will monitor and analyze the types of faculty and student research being conducted and student learning outcomes in required courses. While this effort to create a shared space within the university for interdisciplinary research and study is significant, perhaps the next goal should be to go beyond interdisciplinarity within the institution and to create inter-institutional relations to better and more collectively address the greater environmental issues we all face.

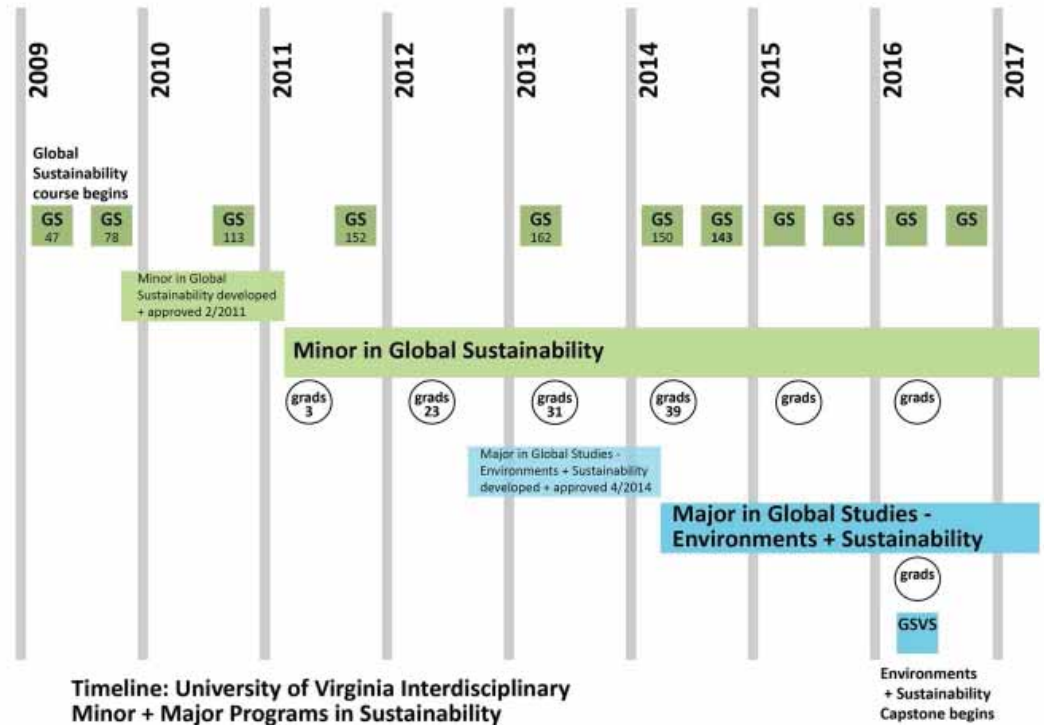

Figure 4: Timeline of Global Studies GSVS Major with Related Global Sustainability Course and Minor.

REFERENCES

Architectural Research Centers Consortium (ARCC), 2015. "Future of Architectural Research." Accessed February 2. <http://www.arcc2015.com>.

Bennett, J. 2010. *Vibrant Matter: A Political Ecology of Things*. Duke University Press.

Becker, C. 2012. *Sustainability Ethics and Sustainability Research*. Dordrecht; New York: Springer.

Boyer, E. 1996. "The Scholarship of Engagement." *Bulletin of the American Academy of Arts and Sciences*.

Campbell, P., MacKinnon, A. and Stevens, C. 2010. *An Introduction to Global Studies*. Wiley-Blackwell.

Coole, D. and Frost, S. 2010. *New Materialisms: Ontology, Agency, and Politics*. Duke University Press.

- Crisman, P. 2007. "Working on the Elizabeth River." *Journal of Architectural Education* 61:1: 84-91.
- Crisman, P. 2010. "Environmental and Social Action in the Studio: Three Live Projects along the Elizabeth River." In *Agency: Working with Uncertain Architectures*, edited F. Kossak et.al., 32-46. Routledge: London.
- Cross, N. 2007. *Designerly Ways of Knowing*. Basel/Boston/Berlin: Birkhäuser Verlag AG.
- Cross, N. 2011. *Design Thinking: Understanding How Designers Think and Work*. Oxford: Berg.
- DeLanda, M. 2005. "Material Complexity." In *Digital Tectonics*, edited N. Leach, D. Turnbull and C. Williams. 14-21. London: Wiley Academy.
- Doucet, I. and Cupers, K. eds. 2009. "Agency in Architecture: Reframing Criticality in Theory and Practice." *Footprint: Delft School of Design Journal*, 4.
- Eade, J. 1997. *Living the Global City: Globalization as Local Process*. London: Routledge.
- Ennis, R. 1962. "A Concept of Critical Thinking," *Harvard Educational Review*.
- Fagan, G. 1996. "Community-Based Learning." *Education for Sustainability*, edited by J. Huckle and S. Sterling, 136-148. London: Earthscan Publications.
- Ferraro, E. and Reid, L. 2013. "On Sustainability and Materiality. Homo Faber, A New Approach," *Environmental Economics*. Volume 96, December: 125–131.
- Findeli, A. and Bousbaci, R. 2005. "The Eclipse of the Object in Design Project Theories." *The Design Journal*, 8, 3, November, 35-49(15).
- Fraser, M. 2013. *Design Research in Architecture: An Overview*. Ashgate.
- Giddens, A. 1984. *The Constitution of Society: Outline of the Theory of Structuration*. Berkeley: University of California Press.
- Global Studies Association (GSA). 2015. Accessed Feb. 2. <https://globalstudiesassoc.wordpress.com/about/>
- Grand, S., Wolfgang, J. and Ralf, M. eds. 2012. *Mapping Design Research*. Basel/Boston/Berlin: Birkhäuser.
- Grand, S. and Wiedmer, M. 2010. "Design Fiction: A Method Toolbox for Design Research in a Complex World." in *Applied Sciences*.
- Gray, C. and Malins, J. 2004. *Visualizing Research: A Guide to the Research Process in Art and Design*. Ashgate.
- Groat, L. and Wang, D. 2013. *Architectural Research Methods*. Hoboken: Wiley.
- Handler, R. 2013. "Disciplinary Adaptation and Undergraduate Desire: Anthropology and Global Development Studies in the Liberal Arts Curriculum," *Cultural Anthropology*, Vol. 28, Issue 2: 181-203.
- Haseman, B. 2006. "A Manifesto for Performative Research," *Culture and Policy*, No. 118: 98-106.
- Hodder, I. 2012. *Entangled: An Archaeology of the Relationships between Humans and Things*. Blackwell.
- Ingold, T. 2013. *Making: Anthropology, Archaeology, Art and Architecture*. Routledge.
- Ingold, T. 2011. *Being Alive: Essays on Movement, Knowledge, and Description*. Routledge.
- Latour, B. 1987. *Science in Action: How to Follow Scientists and Engineers through Society*. Harvard University Press: Cambridge.
- Leatherbarrow, D. 2012. "The Project of Design Research," in *Design Innovation for the Built Environment: Research by Design and the Renovation of Practice*, M. Hensel, ed. London: Routledge: 5-13.
- Lechner, F. and Boli, J. 2012 (4th ed.). *The Globalization Reader*. Wiley-Blackwell.
- Meadows, D. 2008. *Thinking in Systems: A Primer*. Sustainability Institute, Chelsea Green Publishing.
- O'Byrne, D. and Hensby, A. 2011. *Theorizing Global Studies*. New York: Palgrave Macmillan.
- Roth, M. 2010. "Beyond Critical Thinking," *The Chronicle of Higher Education*. Published January 3. <http://chronicle.com/article/Beyond-Critical-Thinking/63288/>
- Rowe, P. 1987. *Design Thinking*. Cambridge: The MIT Press.
- Schneider, T. and Till, J. 2009. "Beyond Discourse: Notes on Spatial Agency" *Footprint: Delft School of Design Journal* 4.
- Schön, D. 1983. *The Reflective Practitioner: How Professionals Think in Action*. Basic Books.
- University of Virginia (UVA). 2014. *Global Studies Interdisciplinary Undergraduate Degree Proposal*.
- Wood, M. 2003. "From Service to Solidarity: Engaged Education and Democratic Globalization," *Journal of Higher Education Outreach and Engagement*, 8, 2: 165 – 181.

ENDNOTES

ⁱ For a comprehensive overview, see *Architectural Research Methods* (Groat, Wang 2013). The authors examine seven architectural research strategies in-depth, including historical research, qualitative research, correlational research, experimental & quasi-experimental research, simulation research, logical argumentation, and case studies & combined strategies.

Intern architects in the academy: Preparing for future practice

Caryn Brause¹

¹University of Massachusetts Amherst, Amherst, MA

ABSTRACT: In the summer of 2014, the National Council of Architectural Registration Boards (NCARB) announced its intention to provide a structured path to licensure upon graduation to qualified candidates. As the period of internship becomes embedded in the academic curriculum, with students eligible to become licensed upon graduation, identifying pedagogical methods that navigate the relationships among theory, design, construction, and practice becomes essential.

This paper documents pedagogical research, supported by the 2013 NCARB Award, that investigates an experiential, field-based model for integrating issues central to architectural practice in curricula to better prepare architectural students for future practice. The paper considers coursework carried out over two semesters, with varied project types, delivery methods, and practice models to evaluate the method's efficacy addressing recurring themes identified in the 2012 NCARB Practice Analysis recommendations. The ongoing research examines a pedagogical model for understanding the myriad issues that comprise contemporary architectural design decision-making and project delivery.

KEYWORDS: NCARB, Practice, Experiential Education, Field Research, Building Technology

INTRODUCTION

The relationship between theory and practice in the architectural academy is a persistently debated topic. Meanwhile, the preparedness of architectural graduates for the profession remains a point of contention and accredited architectural programs continue to maintain a delicate balance between art academy, research unit, and vocational school. (Newman and Vassigh 2014) This summer, the National Council of Architectural Registration Boards (NCARB) announced changes to dramatically shorten the internship timeline to provide a structured path to licensure upon graduation to qualified candidates.¹ The American Institute of Architects (AIA) and the Association of Collegiate Schools of Architecture (ACSA) supported this initiative.²

As the period of internship becomes embedded in the curricula, with students eligible to become licensed upon graduation, the academy must grapple with integrating practical concerns into its courses. As this conference's theme illustrates, architectural practice itself is rapidly advancing through technological changes, advanced construction techniques, shifts in design delivery methods, and changing professional roles, all of which impact architectural design and technical execution. Identifying pedagogical methods to navigate the relationships among theory, design, construction, and practice thus becomes essential.

This paper documents pedagogical research, supported by the 2013 NCARB Award, that investigates an experiential, field-based model for integrating issues central to practice in architectural curricula to better prepare architectural students, or "intern" architects, for future practice. The paper considers course work carried out over two semesters examining varied project types, delivery methods, scales of operation, and practice models. The course is evaluated in reference to recurring themes identified in the 2012 NCARB Practice Analysis recommendations, particularly regarding the availability of sufficiently diverse and meaningful examples. A discussion evaluates the practicality of widely applying this methodology. The ongoing research posits the question of whether sacrificing traditional coursework's subject matter comprehensiveness for applied field-based integration is an effective vehicle for understanding the multiple paths and myriad issues involved in contemporary architectural design decision-making and project delivery.

1.0 BACKGROUND

Architectural coursework typically addresses building and construction technologies through materials and methods courses. Project delivery and professional roles are taught in professional practice seminars, and construction documentation is taught in "integration" or "comprehensive" studios. Each of these course types seeks to provide a comprehensive overview of methodologies and issues in the profession. However, the profession has largely relied on post-graduate internship to allow developing architects to apply information gained in compartmentalized university-based coursework to more holistic project-based work. This practice

setting provides a context in which knowledge is “based on repetitive, socially situated events and relationships.” (Johnston 2012)

The NCARB Practice Analysis provides one metric for identifying when knowledge is acquired and how this knowledge is being used in practice. The 2012 Practice Analysis included reports on Education, Examination, Internship and Continuing Education. The final analysis sample contained 7,867 responses that outline a detailed description of what those respondents believe practitioners need to know, the skills they must possess, the tasks they perform, how frequently those tasks are performed, and the respondents’ ratings of the relative importance of each. (NCARB 2012)

This paper draws upon findings from the Education Report. The data analysis for the Education Report included 2015 responses generated from licensed architects, recently-licensed architects, interns, and educators. (NCARB 2012) The survey asked educators whether specific tasks were covered in their programs and how students performed each task by graduation. Interns and architects were asked to indicate the extent to which they performed specific tasks by the completion of their architecture degree. Educators and architects were asked when specific knowledge and skills should first be acquired, and whether these should be acquired during an accredited degree program. Finally, interns and architects were asked to indicate when they acquired specific knowledge and skills and how these are typically employed in practice. (NCARB 2012)

1.1. 2012 NCARB practice analysis recurring themes

The 2012 Practice Analysis identified eight areas for particular focus and reinforcement within curricula: communication, collaboration, professional conduct, practice and project management, site design, constructability, sustainability, and technology. Additionally, there were Qualitative Findings that to adapt to changing professional demands, curricula should include more on-site experience. Both the Education Survey and the Internship Survey recommended job-site experience to prepare graduates to better visualize the design and construction process and to be able to apply construction knowledge to design.

Recently-licensed architects and current interns indicate that they are gaining knowledge and skills in these areas prior to licensure. At the same time, the practitioners overwhelmingly responded that these capacities should be acquired prior to graduation. By contrast, respondents indicated that their point of acquisition is actually during their internship period. (NCARB 2012)

1.2. Changing circumstances – licensure at graduation

NCARB considers accredited architectural education the “foundation,” and describes the ensuing internship period “as a structured environment where theory and precedent can be applied to actual projects, and knowledge of materials and systems is transformed into thoughtful construction details.” (NCARB 2012, p.118) However, as internship gets pushed deeper into the academy, the discrepancies identified in the Practice Analysis bear further examination.

The concept of licensure at graduation is not an entirely new idea. (Frank 2014) Until recently, the three components of licensure – professional education, practice experience, and registration examination – were undertaken as a linear process. However, NCARB has been steadily changing the relationship among these three components, making overlaps between timelines feasible. For example, since June 2007, NCARB has endorsed early eligibility, or the ability to take the Architect Registration Examination (ARE) while completing the Intern Development Program (IDP). In 2007, approximately 25% of all divisions of the ARE were conducted under early eligibility. By 2014, that number had more than doubled. (NCARB 2014)

NCARB introduced additional changes by expanding eligibility dates so that students could begin earning hours as early as the completion of high school. Moreover, these changes, known as IDP 2.0, broadened the definition of experience settings by permitting interns, whether employed or not, to gain experience in more ways and under a broader range of supervisors. These changes have already created overlaps between internship and the academy. In 2001, the average licensee did not begin to count their IDP hours until after graduation, whereas by 2014, at least half reported IDP experience concurrent with education. New policy changes announced this summer regarding retroactive reporting of earned hours will provide an even greater opportunity to do so.³

However, recent research identified that the median time between graduation and completion of internship is 5.4 years, with an additional two years to complete the exam, so that the path to licensure can still take seven to twelve years. (NCARB 2014) This research has prompted NCARB to take additional measures in an effort to shorten the duration of the licensure process. NCARB has convened a Licensure Task Force with a three-year plan to study how the path could be made more efficient, including the possibility of

integrating internship and examination requirements into a professional architecture degree.

2.0 VOICES FROM THE FIELD EXPERIENTIAL SEMINAR

If the point of acquisition of capabilities that NCARB deems “central to practice” are increasingly removed from the practice setting, formats must be developed that can mirror this environment within academy. One such format is being explored through an experiential seminar entitled “Voices from the Field.” Supported by the 2013 NCARB Award, the course puts forth a method for examining the integrated relationship between concept design and technical execution by examining active building projects with practicing architects to advance an understanding of the myriad factors that impact design decisions during construction. In doing so, the course takes topics that are sometimes difficult to understand in an academic environment and links them to real world examples, thus providing students with direct experiential knowledge of critical practice issues.



Figure 1: Job-site visit with non-faculty practitioner

The project addresses many of the recurring themes and qualitative findings identified in the 2012 NCARB Practice Analysis. Central to this effort is establishing an early understanding of construction sequences and familiarizing students with the Architect’s role from design to construction and maintenance. The course was piloted in the Spring 2014 semester and was tested again in the Fall 2014 semester. This enabled an analysis of the differences in construction practices between seasons. The course structure evolved over the two semesters maintaining consistency in its activities and assignment types. First, students were provided with construction document sets for review. Next, student facilitators presented a critical context for each project in a seminar setting. In their presentations, they reviewed the project’s financial and institutional details, and presented research on the project team and project delivery method. Then, supported by the faculty member, students led a walk-through of the construction document set, highlighting primary as well as unusual materials and construction methods, noting drawing conventions, and supplementing with relevant information. Finally, they gathered a list of questions for meetings and site visits with practitioners.

Students also visited the active construction sites accompanied by the corresponding non-faculty practitioners. (Fig 1) Students compared the topics that were studied in the classroom with the reality of the construction progress at the site. Following the site visits, students synthesized and reflected on their experiences by composing individual Field Observation Reports. The Field Reports included photographs juxtaposed with annotated excerpts from construction documents, and written descriptions of the transformations that occur from drawing to construction. Field Reports also included written reflections on aspects of the design and construction process that were not readily apparent from the construction documents alone, particularly issues of project management, construction scheduling, collaboration, the role of technology, and professional conduct. (Fig. 2)

OBSERVATION 01 BRICK FACADE

While looking through the drawings, I understood that the majority of the facade of the building was brick, but I didn't look closely at how the bricks would be connected to the structure, and what was going on behind the brick veneer. It wasn't until the site visit when I saw the details in the brick facade and how it connects to the wall behind. One aspect of this wall system that I found very interesting was how metal brick ties protruded through the spray-on insulation, to fit between rows of bricks to anchor them to the wall.

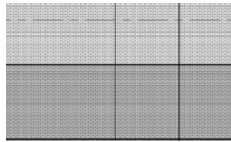

A201 Brick close-up on West Elevation



Left: Air Space Between Insulation and Bricks

Brick ties are placed every 16" on center horizontally, and vertically. This anchors the brick wall to the structure of the building. The ties can be seen in the section below, and poking through the yellow insulation in the photo to the left.

The green mesh is meant to break up the mortar that falls down the air space during construction, so that air can still pass through this area and exit or enter the vents at the bottom.

A324 Wall Section with Brick Facade

Left: Venting Screen Detail

At the base of the brick wall, there are small screen vents between every three bricks that allow more airflow behind the wall. The exposed metal trim is flashing that helps divert moisture out of the wall where the vents are. The project architect explained that in the past, they didn't allow enough space, and proper venting. This system provides a 2" air space and vents on the bottom and top of the wall.

Figure 2: Field report connecting construction documentation to site observations. Source: (Dylan Brown 2014)

3.0 RESEARCH QUESTIONS

There are several research questions embedded in this work. The first question concerns course content. In particular, the work inquires whether sampling available projects from a mostly rural region will enable the course to cover a sufficiently broad spectrum of project types, project issues, and professional roles to address the 2012 NCARB Practice Analysis Recurring Themes.

The author began this study with the hypothesis that the University's \$500 million construction plan over the next decade would provide a stable base of course material, and that the local architectural community would supplement with smaller projects. It was unclear at the outset whether there would be sufficient diversity of project and construction types and whether there would be sufficient opportunity to examine projects at varying stages of construction due to New England's inclement weather and project scheduling.

A second research question concerns student-learning outcomes. This research inquires whether the experiential learning through interacting with practitioners and personal observation on construction sites yields a deep integration of concepts, and whether the course structure and assignments provide for good retention and "stickiness." (Cheng 2013) Collection of data to evaluate this question is ongoing and will be presented in a future paper.

3.1. Method and data results

Logging each semester's construction site visits by project type, size, budget, delivery method, stages of construction observed, primary structure systems, and targeted energy benchmarks demonstrates the diversity of experiences.

During the Spring 2014 semester, students reviewed construction document sets for five projects, and made seven site visits, including three projects on the University of Massachusetts Amherst campus, and two projects regionally. Architectural practitioners included a recent graduate, at a large multi-national firm, a Campus Planning architect, and three architects with more than ten years in practice. Despite a long, cold, and snowy winter, students were able to observe projects in a range of construction phases. They also visited one completed project. Projects visited were delivered through traditional Design-Bid-Build and CM at Risk methods. (Table 1)

During the Fall 2014 semester, students reviewed construction document sets for five projects, and made six site visits, including one project on the University of Massachusetts Amherst campus, and four projects regionally. Architectural practitioners included recent graduates, at a sizeable multi-national firm, a Campus Planning architect, and three architects with more than ten years in practice. Students were able to observe projects in a similar range of construction phases. Projects were delivered through traditional Design-Bid-Build, CM at Risk, and Integrated Project Delivery methods. (Table 2)

Table 1: Project distribution spring 2014 semester

Project	Type	Size	Budget (millions)	Firm Size	Phases Visited	Structure	Rating System	Delivery Method
Integrative Learning Center (ILC)	Academic	150,000 sf	\$93.25	14,000	Interior Finishes Millwork, MEP	Steel	LEED Gold	CM At Risk
Football Performance Center & Pressbox	Athletics	55,000 sf 5,800 sf	\$34.50	1,600	Cladding, Interior Build-out, MEP	Steel	LEED Gold	CM At Risk
Bechtel Environmental Center	Classroom	2500 sf	\$1.79	8	Complete,	Wood: glulam	Living Building	Design-Bid-Build
Powdermill Village	250 unit Affordable Housing Retrofit	240,000 sf / First Phase: 8,900 sf	\$3.00, First Phase: \$400,000	8	Testing retrofit strategies	Wood	30-40% energy savings	Design-Bid-Build / Design-Build
Champion Center	Athletics	56,500 sf	\$19.00	90	1: Sitework, Foundations 2:Steel	Steel	LEED Silver Min.	CM At Risk

Table 2: Project distribution fall 2014 semester

Project	Type	Size	Budget (millions)	Firm Size	Phases Visited	Structure	Rating System	Delivery Method
Champion Center	Athletics	56,500 sf	\$19.00	90	1: Brick Cladding, Interiors 2:Curtain Wall, Interiors	Steel	LEED Silver Minimum	CM At Risk
Bechtel Environmental Center	Classroom	2500 sf	\$1.79	8	Complete,	Wood: glulam	Living Building	Design-Bid-Build
Plains Elementary School	Pre-K-2	63,400 sf	\$28.00	10	Sitework, Foundations, Steel Structure, CMU	Steel, CMU	LEED Silver Min.	Design-Bid-Build
Parson's Village	38 Unit Affordable Housing	32,430 sf	\$12.00	21	Sitework, Utilities, Foundations, Structure, Windows	Wood Frame with Roof Trusses	Zero net energy with PV's	Design-Bid-Build
Baystate Hospital of the Future South Wing & Pharmacy Relocation	Healthcare Fit-Out	70,500 sf + Pharmacy: 14,000sf	\$33.00 + \$5.5	150+	Interior Build-out, MEP, Millwork Mockups	Steel, Curtain wall, CMU	MA Stretch Code, Green Guide for Health Care	Integrated Project Delivery (IPD)

3.2. Analysis of student assignments

The primary assignment was to complete the Field Reports submitted following each site visit. Each Field Report comprised ten observations, with students required to submit five per semester. With fourteen students in the spring and twelve students in the fall, the Field Reports yield 1492 data points regarding how often "Issues that are Central to Practice" were explored and how these align with the "Recurring Themes" identified by the 2012 Practice Analysis. The total data points for each project varied as some students made multiple points per "Observation" while other students did not meet the requirements. (Table 3)

Observations necessarily interrelate. For the purposes of this study, a data point was logged in Constructability if the student paper was primarily discussing the construction detail and implementation, whereas it was logged in Sustainability if the student observation discussed the detail's impact on the energy performance of the project. Similarly, if the student observation concerned the way in which the architect implemented the work with respect to Construction Administration or issues of the project contract, that point

was logged in Project Management. A future paper will discuss the degree to which students were able to comprehend the interrelationship of these issues and their impact on design decisions.

Table 3: Distribution of 2012 NCARB practice analysis recurring themes exhibited in field reports

Recurring Themes	Constructability - Structures, Systems, Materials, Methods	Constructability - Building Codes	Professional Conduct	Site Design	Project Management / Construction Administration	Role of Technology	Sustainability	Collaboration	Documentation	Design	Total
Integrative Learning Center (ILC)	71	12	0	3	6	0	7	10	11	0	120
Football Performance Center & Pressbox	102	27	0	3	16	0	0	0	0	0	148
Bechtel Environmental Center (2 visits)	165	7	6	35	3	0	92	0	10	0	318
Powdermill Village	84	0	41	0	17	0	6	4	25	0	177
Champion Center (2 visits)	164	3	0	6	70	5	20	2	3	0	273
Plains Elementary School	98	0	0	5	18	0	9	5	0	11	146
Parson's Village	90	9	2	13	20	0	8	0	1	0	143
Baystate Hospital of the Future	102	0	0	0	32	6	0	14	0	13	167
Total Observations	876	58	49	65	182	11	142	35	50	24	1492

3.3. Analysis of student survey

Additional data is extracted from a survey conducted at the conclusion of the Fall 2014 course. Students were asked to indicate on a 5-point scale whether the course increased their understanding of the following topics: Constructability, Project Management, Sustainability, Professional Conduct, Collaboration, and the Role of Technology. Each topic employed questions with language adopted from the 2012 Practice Analysis.

4.0 FINDINGS

The tables describing Project Distribution, the analysis of data points extracted from student Field Reports, and the results from student surveys describe a course with a robust diversity of project types and budgets, construction materials and methods, sustainability targets, and project delivery methods. Additionally, meeting with a broad variety of non-faculty practitioners enabled students to discuss myriad issues relating to professional conduct, ethics and the architect's role from project inception through construction, and maintenance. The non-faculty practitioners ably articulated issues identified in 2012 NCARB Practice Analysis that applied to their projects and professional practice. The student's Field Reports demonstrated that these complex topics were made accessible to them.

Given the stated emphasis of the course, it is not surprising that the overwhelming number of data points logged from student Field Reports (58%) concerned Constructability, particularly building structures, systems, materials, and methods. Another 4% concerned with Constructability relating to Building Codes. In their comments, students noted how the course changed their thinking about the relationship between design intent and constructability, particularly the level of technical expertise required to take a concept they might include in a studio project through detailing and construction, such as the thickened roof plane at the Champions Center.

Students cited Project Management 12% of the time in their student observations and indicated in their survey that they gained an understanding of various project delivery methods as the implications of the delivery method was discussed in context on every site visit. Student observations specifically referenced Sustainability issues 9.5% of the time. The NCARB Practice Analysis separates out Sustainability as an

“Issue.” However, in the projects studied, Sustainability was inseparable from Constructability. Many of the details students observed were discussed in relationship to achieving energy performance targets. Student survey comments addressed how the course changed their understanding regarding the ways in which these performance targets influenced design decisions. They also noted how much they learned about the role of site planning and design in achieving these targets; site issues were discussed in 4% of the Field Reports. While student Field Report observations addressed Professional Conduct and Collaboration issues less overtly, the survey comments indicated that they had a greater understanding of the variety of architects’ collaborators and the necessity for collaborative skills in a professional setting.

The students brought an encouraging level of integration to their observations, and they developed increasing sophistication and understanding over the course of each semester. At the beginning of the semester, when arriving at their first site visit, students were often perplexed by the sheer amount of unfamiliar materials and infrastructure that they were seeing and experiencing. Similarly, they were overwhelmed at first by the complexity of a 100+ page construction document set. However, as the semester progressed, students were able to more easily identify what they were seeing onsite, ask targeted questions and make connections between projects. This familiarity is confirmed by responses to the survey.

4.1. Discussion: logistical challenges

There remain logistical challenges to providing sufficient diversity of project and construction types, project issues, and professional roles as well as sufficient opportunity to see projects at varying stages of construction. The University’s \$500 million construction plan should provide a steady base for sampling construction. While this was true for the Spring 2014 semester, it did not similarly unfold for the Fall 2014 semester, as there was only one active building project on campus.

The cyclical nature of the architecture and construction industry provides additional challenges. Some projects scheduled for visits in the spring did not start until the fall due to financing. Sourcing diversity of construction stages is particularly challenging; despite course planning efforts, delayed construction schedules might yield a semester when all the projects are roughly in the same stage of construction. Local weather and construction work hours are also factors; snow days affect highly choreographed field trips, early darkness renders it difficult to move safely on a construction site. However, lessons learned these first two semesters make the author optimistic about crafting diverse project samples in the future.

5.0 BROADER IMPACTS

NCARB is poised to overhaul the Intern Development Program (IDP) in 2015-2016. The changes are designed to make the process more efficient, less focused on minutia, and more focused on capturing the “big picture” of the great variety of activities, building types, practice types, and projects that comprise contemporary practice. (Serfass 2014) Precisely how these shifts impact the potential for licensure upon graduation is currently being studied.

Currently, under IDP, interns may accrue up to 40 out of 120 core hours in the Construction Phase experience area for visiting construction sites with a mentor as a recognized supplemental experience. The Voices from the Field course meets all the NCARB expectations for such an experience.

However, at present, students cannot simultaneously obtain academic credit hours and IDP hours, as NAAB student performance criteria must be met by for-credit courses while IDP hours cannot be met by these same credit-bearing courses. As the academy analyzes curricula to be positioned to graduate licensed or nearly-licensed architects, this policy will need to be addressed. In the not-too-distant future, the Voices course, for example, might offer three credit hours and the possibility of ten to fifteen core IDP hours.

This has multiple implications for the curriculum and raises questions that directly address this conference’s themes. Will an emphasis on creating a path for licensure upon graduation produce a two-tier system of courses, with some bearing IDP hours and others not? IDP core hours necessarily bear a direct relationship to the knowledge, skills and tasks required to practice in “today’s marketplace” as identified in the Practice Analysis. (Serfass 2014)

Would such a system deter the more speculative courses that have the potential to advance the field in currently unforeseen ways? The germs of future practice may reside in experimental studies conducted in the academy. Would courses that do not appear to be applicable to *today’s* marketplace, but rather, to tomorrow’s, wither as students concentrate on the most expedient path to licensure?

CONCLUSION

The Voices from the Field course successfully tested a pedagogical model for integrating issues central to architectural practice in academic architectural curricula. Based on an evaluation of the projects studied and an analysis of student assignments and survey responses, this model forms an effective vehicle for understanding the myriad issues that comprise contemporary architectural design decision-making and project delivery. As such, its experiential, field-based format offers one approach to consider as the academy looks for models that will navigate design and construction, theory and practice. As this conference's manifold themes illustrate, design is advancing in the academy and in the field, through practice and through research. Positioning students in the field while they are still in school introduces them to the challenges of emerging practice issues as they are unfolding and enables students to engage these issues while they are tested on active projects.

ACKNOWLEDGEMENTS

This project was funded by the 2013 National Council of Architectural Registration Boards Award for the Integration of Practice and Education. The author would like to acknowledge Professor Kathleen Lugosch FAIA, Graduate Program Director and co-PI on this Award, for her collaboration. Thanks to students Rachel Beesen, Dylan Brown, and Amy Carbone for their project support.

REFERENCES

- Cheng, R. 2013. "A Better Path to Practicing." *Design Intelligence*, February 1.
- Johnston, G. 2012. "Professional Practice: Can Professionalism Be Taught in School?" In *Architecture School - Three Centuries of Educating Architects in North America*, 370–73. Cambridge, MA: MIT Press.
- "Licensed at Graduation: NCARB Endorses Plan for Architecture Students to Complete IDP, Examination While in School." 2014, June 2. <http://acsa-arch.org/acsa-news/read/read-more/acsa-news/2014/06/02/licensed-at-graduation-ncarb-endorses-plan-for-architecture-students-to-complete-idp-examination-while-in-school>.
- National Council of Architectural Registration Boards. 2010. "IDP 2.0 The Final Phase." *Direct Connection: A Publication of NCARB*.
- . 2013. *2012 NCARB Practice Analysis of Architecture*.
- . 2014. *NCARB By the Numbers*.
- Newman, W., and Vassigh, S., 2014. "What Would Vitruvius Do? Re-Thinking Architecture Education for the 21st Century University." *Beyond Architecture: New Intersections & Connections | University of Hawai'i at Manoa*, 67–74.
- Ockman, J., and Williamson, R. 2012. *Architecture School - Three Centuries of Educating Architects in North America*. Cambridge, MA: MIT Press.
- Serfass, N. 2014. "What You Need to Know About the Proposed IDP Changes." June 19. <http://blog.ncarb.org/2014/June/IDP-Proposals.aspx>.

ENDNOTES

¹ "NCARB Endorses Additional Path to Becoming an Architect: Architect License Upon Graduation." 2014, May 30. <http://www.ncarb.org/News-and-Events/News/2014/05-BODendorsesLTF.aspx>.

² See, for example, Scott Frank, "AIA President Lauds Additional Path to Licensure for Aspiring Architects," June 5, 2014, <http://www.aia.org/press/AIAB103933> and "Licensed at Graduation: NCARB Endorses Plan for Architecture Students to Complete IDP, Examination While in School," June 2, 2014, <http://acsa-arch.org/acsa-news/read/read-more/acsa-news/2014/06/02/licensed-at-graduation-ncarb-endorses-plan-for-architecture-students-to-complete-idp-examination-while-in-school>.

Questioning the role of online education in the architectural design studio

Craig Griffen¹

¹Philadelphia University, Philadelphia, PA

ABSTRACT: The recent significant increase in programs offering general education online is causing much debate about how it does, or how it will, affect architectural education specifically. Lecture-based online courses have been more openly received as an opportunity to disseminate instruction to a larger and far-ranging audience. While not without its flaws, the method translates well to online delivery. On the other hand, teaching design studios via the same method has been cause for much more concern. The strength of the studio methodology has long been based in its immediacy of face-to-face interaction between teacher and pupil as well as the camaraderie and community of a shared experience; assets harder to translate over distance. Since traditional studio methodology relies so heavily on people being together in the same physical space, many do not understand how this pedagogy can be recreated at a distance. Through a university-funded research grant I have been studying online studio education through four programs that have been teaching online studios for several years and therefore have a solid track record. I have distilled general patterns common to all programs into categories of *Advantages*: Opportunity, Documentation and Democratic and *Challenges*: Separation, Methodology and Technology. We now have a solid first set of results with which we can evaluate the problem to understand which initial concerns are still valid, which may be unfounded and which is the best direction to proceed.

INTRODUCTION

The advent of new technology in any field is often met with a mix of heightened expectations and cautious trepidation so an anxious reaction to the introduction of online technology into architectural education is not surprising. Like CADD and BIM technologies that preceded it, the technical aspects of online instruction, just emerging from *its* infancy, will likely overcome some of the initial misgivings but I believe there are deeper pedagogical questions not solvable by improved technology alone. In distance learning, computer technology is the substitute interface for physical presence but can it (and if so when will it) develop far enough to equal the personal interaction of one-on one instruction? During my research I have encountered a good deal of doubt from educators about the effectiveness of online architectural education in general and even greater apprehension about distance studio education in particular. Practically all faculty members teaching now were educated under the traditional onsite studio format. With its face-to-face exchange of ideas of student and professor, immediacy of feedback and camaraderie among peers, it has proven to be an effective method for decades. Since this studio methodology relies heavily on people being together in the same physical space, many faculty members do not understand how this smooth-running pedagogy can be recreated at a distance. Several faculty currently teaching online studios admitted even they had doubts as to how it would work when they first started (but most have since been converted).

To understand where online studio education stands and where it may be going, I spent the past year studying the three programs recognized by ACSA in the US and one in Europe that have been teaching online studios for several years so therefore have a solid track record.¹ As a result of a research grant I received from my university, I researched programs at Boston Architectural College (BAC), The Academy of Art University (AAU) in San Francisco and Lawrence Technological University (Lawrence Tech) outside of Detroit as well as the European school of EU University in Spain. Through a combination of email and phone interviews, in-person visits to the school and participation in online design reviews, I have been able to distill general patterns of both the advantages and challenges common to all the programs based on the responses I received.² My disadvantage of not having taught an online studio was compensated by my ability to serve as an impartial outside observer who could objectively assess what is working well and what problems still exist.

First it is best to establish the logistics of these online programs in terms of basic numbers. All of the programs I studied were graduate level programs in schools of architecture. The shorter length of the masters programs better fits with online programs that are easier to coordinate over a shorter time frame. (While there are plans for starting undergraduate online programs, these are still too undeveloped to evaluate) The average length of the online programs varies but for those with prior architecture diplomas the degree can be earned in 3 to 5 semesters. For those with non-design related degrees the time increases to about 7 to 8 semesters. Each studio contains 8 to a maximum of 15 students although many can be smaller due to lower enrollments in a given semester. All these schools also offer onsite programs

so accreditation standards for NAAB are exactly the same. It is up to the schools to prove to the accreditation board they are meeting the criteria no matter what the delivery method. A side benefit being courses can often be taken in a combination of online and onsite if the student so chooses. However, regional university accreditation requirements vary and may be stricter.

1.0 THE BENEFITS – SHARED ADVANTAGES

1.1. Opportunity

By far the most cited benefit to online education is opportunity; the opportunity for students, faculty, consultants and critics to share ideas from anywhere in the world with an Internet connection. By breaking down the barriers of distance through computer technology, location is greatly reduced as an obstruction to a quality education. All online architecture programs I researched are at the graduate level because this is the main audience. Students who have an undergraduate degree and have been out of school for several years may desire to add a Master's degree to improve their position or change a career. However, by this time many have jobs and/or spouses with careers they cannot or do not want to leave for personal or financial reasons. Some also have started families and can't easily uproot the children for two years to obtain another degree. Distance learning allows them to live where they want and keep their jobs while having access to high quality faculty instruction. As an example, during one online review I participated in for BAC, students were linked in from New York, North Dakota, Connecticut, Massachusetts, Texas and Missouri. Programs that do not have a residency requirement (in person visits to the school for a short period of time) are able to attract students internationally. The need to travel to the school once at the beginning of the program or up to once every semester usually limits that program to US based students. AAU's program does not have a residency requirement so that allows them to draw more students from abroad. For example, a recent studio at AAU included members from Brazil, California, St. Louis, Dubai, Indonesia and Taiwan.

Just like students, faculty members also do not need to be onsite to teach. Most programs do have a group of onsite faculty who form the body of instructors at the main school. But online presents special opportunities for studios with professors from abroad. For example at AAU a professor in Finland taught a studio with project sites based in Finland, Tokyo and London. Which brings up another benefit, the ability to receive information from professionals around the world. Through online reviews, foreign critics and consultants can share their expert knowledge with the students such as in one recent studio where the critics were connecting from Oakland, London and Bangalore. It is not so important if the leader in a certain field is not local as you can bring them into the conversation via online web conferencing. A drawback to this is the time difference around the world, as you need a dedicated critic who is willing to join in a review at four o'clock in the morning. However, this type of communication schedule mimics the similar situations the students will find in practice. The architecture profession is increasingly working in collaborative groups around the globe that communicate through web conferencing, the same method used in studio.³ Receiving this type of real world experience before they graduate is something not usually found in a typical onsite education.

1.2. Documentation

In a typical onsite studio drawings are done on a variety of media, vellum, trace, napkins, etc., and may be presented piecemeal through the semester. Because of this work can get lost or destroyed or forgotten. With an online studio all work must be posted in regular intervals online, forming an accurate record of all written, drawn and built work. This work is continually available to the student and professor so there is clear documentation of progress through the semester. Reviews are sometimes audio/video recorded as well so the student can return to reevaluate their critique two or three times to make sure they comprehend all that was said. This collected work also makes it easy to access the necessary documents for assessment when needed. Instead of collecting only high pass and low pass work, all the work can be captured. The requirement for students to constantly post work keeps them on schedule and aids in their preparation. If a project is late there is an obvious empty folder that all students and faculty can see. The student must be disciplined to submit work on a regular basis or it will show to all.

1.3. Democratic

The online studio introduces a new social dynamic not found in the onsite model. The Internet can act as a leveling device to give each student's opinions and ideas greater equality, exposure and consideration. In an onsite studio a few talkative students rise above the rest and may dominate the conversation or direction of the studio. In the online format where people are more anonymous, shy students are more willing to speak up (or rather, type up) outside the group dynamic. Ironically, the physical isolating effect of the Internet (that I will discuss shortly) can actually be helpful to quiet students. Live video streaming of peoples faces is sometimes problematic due to slower bandwidth speeds so most communication is done without it

and therefore the student may feel more comfortable contributing. Not having to worry about being watched or how your appearance is being perceived helps combat the universal fear of public speaking.

2.0 THE CHALLENGES

2.1. Separation

Of the challenges that still face online studio instruction, I think the greatest is what many might suspect, the physical separation of students from faculty, each other and critics. Because the studio instructional pedagogy leans so heavily on face-to-face contact, the interconnectedness of a room filled with students, pens (or keyboards) in hand, bouncing free-flowing ideas off each other, is just not yet replicable by computer technology and is unlikely to happen in the near future. So compensating for the lack of intimacy and community is a major challenge. The directors and faculty of the programs have done an admirable job in utilizing computer software to try to recreate a community. When these fall short, the tech savvy students in our digitally connected media age have taken the matter into their own hands to create unofficial social networks to connect to each other. (Students even Skype with their laptops open and the camera pointed at themselves for hours to recreate the sense of working together with others.) But no technology yet supplants the value of physically coming together as a group as seen by the great significance programs place on the sense of community created by their residency programs. Schools that have them view them as critical to the success of the program and those that don't are considering adding them. Bringing everyone together at the beginning of a program or on a regular once-a-semester basis allows the group to bond, which subsequently makes the online community stronger. To further strengthen this, students are usually kept together in a cohort and take all their studio courses together over the length of entire program. I was invited to visit BAC for one of their once-a-semester residency program they call the Intensive week when all students travel to Boston and stay as a group in a hotel for a concentrated 8 days of work. During this time, bonds between students are created or renewed by "living through" the rigorous requirements as a group. Seeing this confirmed the power of the residency program and I found it slightly ironic and telling that one of the keys to distance learning is physical presence.

Beyond building community, the residency programs also compensate for another challenge of online studios, the loss of immediacy; the ability to quickly and clearly interchange ideas. Online studios have reduced ability to directly communicate what is being asked. This is especially true for career changers without an undergraduate degree in an architecture-related field. They do not fare as well as students with design-related degrees who are already familiar with the culture and "language" of the architecture studio. (Because of this, most schools studied only accept students with architecture-related degrees) For example, an architecture student would understand what to do if asked to build a model but a student coming from an accounting background may not understand what was required. They say, "Show us an example". Having the ability to immediately see and hold various examples of the physical object and precisely point out the details is a benefit of onsite studios not enjoyed by online.

The separation also makes it easier for the distractions of real life to interfere. Job deadlines and family emergencies have greater effect and students may "disappear" for a while without any communication. When a student or instructor doesn't post, the other can get annoyed. One school estimates that 10%-15% of its students are less engaged than desired. Keeping on track requires much greater discipline. Some online students become so frustrated with the distance that they move to the university location to take classes on-site. Most programs employ a once a week synchronous meeting to "bring everyone together" at a common time but the one-on-one desk crits can happen separately at any hour of the day or night. Good time management skills for both students and faculty are crucial.

2.2. Methodology

The online studio teaching methodology is very different from traditional teaching styles and requires instructors with a totally different mindset. Some professors accustomed to teaching a certain way for years do not adjust well to the online method. While many instructors admit to being skeptical at the beginning, any teacher asked to teach online must be open and willing to adjust their methods. All instructions must be very specific (even more so with career changers) so all project documents must be meticulously written as there is less opportunity to verbally embellish "in class". This extra preparation means that developing an online studio often takes *more* time to prepare than a typical studio. Professors must also be willing to teach on a flexible time schedule. Students with jobs and families have little free time to converse so much communication is done in the evenings or on weekends. Foreign students in greatly different time zones make this even more challenging. Finding faculty to work on such erratic schedules takes patience and effort.

2.3. Technology

When I first began my research I was looking forward to discovering which fantastic software programs and computer hardware gadgets were being used in online studios. I imagined wonderful seamless graphic interface software and smart tablets that made desk crits a breeze. I was a bit surprised to learn that a major challenge to online studios is the limitations of digital technology that have not kept pace with the pedagogy. Since AAU has a large population of distance learners in many majors, they found it feasible to develop proprietary software Learning Management System (LMS) that handles much but not all of the communications. They, like the other programs, also rely on a series of existing web conferencing and communication software to fill in the blanks. Over the years a variety of software has been tested by the schools and retained or replaced based on effectiveness. The list includes programs like Blogger, Voice Thread, WebEx, Adobe Connect, Moodle, Facebook, Skype, Twitter WhatsApp and more, but no one software currently dominates. Currently studios can use up to *four* or more different software programs to manage assignments, communicate between instructor and students, socially interface between students and conduct reviews. However singular programs that combine all functions into one are rumored to be developed so interface communication will likely improve with time.

Computer hardware has also proven to be less than adequate for the online pedagogy. Special equipment is either not available or easily affordable by both the schools and the students. The laptop remains the most commonly utilized piece of hardware, but since most people own one that is also a great equalizer. I was fortunate to be a guest critic for a couple of online reviews for the BAC in which all faculty, students and reviewers "attended" in different states through the WebEx program on their laptops. Not having to own special equipment makes it easier for nearly anyone to participate. Because the students were well prepared, the review overall went very smoothly. Being able to see only one image at a time on the screen and flipping back and forth can be frustrating, but digital onsite studios often encounter this same problem. I did not miss seeing a streaming video image of the students themselves but a static picture might have been beneficial to put a face to a name. On the other hand, judging the work solely on its own merits without any cultural biases is a more democratic process. Since my computer was not set up with quality microphones and speakers, it was recommended I call in via a landline phone to improve audio clarity and reduce the bandwidth usage. This worked fine but holding the phone to your ear for 2 hours gets tiring. Having the best software and hardware does make communication easier but the need to Gerry rig it all together with current computer technology is not the optimal approach, leaving plenty of room for improvement.

CONCLUSION

Maybe online education will never adequately replace traditional onsite instruction regardless of how much technology improves. But that may be beside the point. The greater question may be is there a need to replace our current methodology or can we use online learning as one of many tools in the toolbox to enhance of our existing already proven methods? Online education opens up fantastic new opportunities for exchange of knowledge regardless of location but it may not be the best solution for everyone. If we learned our lesson from CADD and BIM, we should not dread the technology aspect of online as a looming problem. In that way we can embrace online teaching as another pedagogical approach to increase the effectiveness of our teaching by adding a whole new demographic to enrich architectural education.

NOTES

¹ See: <http://www.acsa-arch.org/schools/special-programs/online-architecture-programs>

²Philadelphia University Nexus Online Research Grant, 2013-14, I am deeply grateful to the following persons who provided assistance and whose responses are collected in this paper:
Boston Architectural College; Tom Parks, Michael Wolfson
Academy of Art University: Eric Lum
Lawrence Tech: Martin Schwartz, Scott Schall
EU University Spain; Manuel Ocaña

³ *It's a very good time to develop your firm's collaboration skills*, Andrew Pressman, Architectural Record, April 2009

Recalibrated: An interdisciplinary, studio-based study of massive timber for student housing

Dustin Albright¹

¹Clemson University, Clemson, SC

ABSTRACT: The demand for sustainable buildings is continually evolving to be more comprehensive in its scope. In addition to focusing on energy performance and efficiency of usage, designers are increasingly emphasizing a life-cycle approach that recognizes the energy embodied in construction materials and processes. This trend is paving the way for new massive timber products, such as Cross-Laminated Timber (CLT), which offer minimal carbon footprints and compelling advantages in constructability. Following a period of rigorous testing, CLT will be recognized for the first time in the 2015 IBC. Additionally, new CLT producers are emerging in North America. What remains is the education of architects, engineers, and contractors who are often reticent to embrace new and unique building technologies.

This paper describes the work of the 2013 Graduate Comprehensive Studio, which was challenged to design campus-housing solutions for underserved graduate student populations. Recognizing the opportunity to introduce massive timber to next generation designers, and guided by the conviction that project constraints promote ingenuity, we asked students to utilize prefabricated CLT panels as the primary structural material. The size and scope of the project program was ideally suited to CLT, whose economy derives from repeatable geometries and rapid on-site construction with small crews.

The Studio was administered by three architecture faculty with complimentary areas of expertise. Additional industry guidance was provided by professionals experienced with CLT, and a representative from the university's housing department acted as our client. Finally, the studio operated in close collaboration with three Civil Engineering students and their advisor who were concurrently engaged in researching CLT and its capabilities.

This paper presents a selection of findings related to the effectiveness of CLT for innovative student housing solutions. It also considers the merits of this interdisciplinary studio setting for material-based exploration, and describes funded research spurred by this initial project.

KEYWORDS: Massive Timber, CLT, Interdisciplinary Studio, Student Housing

INTRODUCTION

In the Spring of 2013 a unique, interdisciplinary design studio was devised to address two contemporaneous University interests. From a programmatic standpoint, there was a stated desire for dedicated campus housing options for graduate and married students. From a research standpoint, members of the University's administration along with an exploratory team of faculty were engaged in planning a new institute focused on advanced wood and timber technologies. Taken together, these catalysts led to a dynamic, research-driven studio experience with deep and on-going impacts in the practices of two departments, and in the broader discourse related to massive timber structures.

1.0 PROJECT BACKGROUND

1.1. Alternative student housing

An ongoing redevelopment plan for the northeast corner of our campus anticipates a significant increase in housing options for upper-class students. The new development aims to retain a greater number of students in campus housing while adding retail, dining, and other recreational programming. However, it will not address the persistent lack of campus housing for graduate students, married students, and other alternative populations. This was not an oversight, but rather a calculated decision. Early versions of the new master plan were careful to include dedicated housing for the graduate community, but planners encountered high cost estimates, and were thus faced with the prospect of higher rental rates. This presented a challenge to staying competitive with the private market.

In his opening presentation to our Studio class, the director of University Housing described the economic advantages of the private developers. In particular, he stressed that the University's commitment to consistency, durability, and longevity (50+ year life-span) requires higher quality materials and construction

than are seen off campus. This equates to higher material costs and longer, more expensive construction periods. Ultimately, the campus planners steered away from graduate housing on the new site in favor of higher density development, a scenario they felt was more suitable for undergraduate living.

With this history in mind, the Comprehensive Studio was challenged to think critically about the University's conclusions and the various assumptions made about graduate and married student housing along the way. Working in pairs, the students were charged with re-balancing the economic equation, and ultimately found success by combining the following strategies:

- Pursuing dense, multi-family arrangements without assuming that they are ill-suited to graduate and married populations
- Utilizing pre-fabrication to maximize quality and limit on-site construction time
- Designing for energy and water efficiency and thereby limiting operational and infrastructure costs
- Proposing alternative programming that prioritizes the unique opportunities associated with the given sites (and the larger University setting) rather than mimicking the amenities found in off-campus complexes

As the course progressed, student teams were given a series of opportunities to present these strategies to a diverse team of faculty members¹, as well as collaborators from the Civil Engineering department², and our project partner in University Housing³. The students, in turn, received a broad range of critical perspectives to help refine and develop their design and marketing concepts (e.g. Fig. 1).



Figure 1: Student presentations. source: (photos by author 2013)

1.2. Massive timber

Our state boasts a large timber industry (\$759 million harvested per year) and its pine forests represent a significant and renewable natural resource (SC Forests, 2014). Additionally, our campus itself features close to 17,500 acres of contiguous forestland whose operations have been certified under the Sustainable Forest Initiative (SFI), a leading third-party certification program. Citing these resources and the potential for our land-grant University to contribute to economic development in the state, members of the Board of Trustees and upper administration were interested in expanding wood-focused research. In the months leading up to the 2013 Comprehensive Studio, a small group of faculty from Architecture, Civil Engineering, Forestry, and Materials Science responded by laying out plans for the new Wood Utilization + Design Institute. The WU+D Institute aspired to involve each of these constituent disciplines in collaborative, full life-cycle research aimed at advancing the use of wood products in sustainable and resilient construction. The Comprehensive Studio presented an ideal vehicle for developing a model of design-focused collaboration. With this in mind, we chose to explore the topic of Cross Laminated Timber (CLT), an advanced massive timber system with untested potential for Southern Pine utilization in our region.

Developed in Europe in the early 1990's, CLT is a pre-fabricated structural panel that can be used for walls, floors, and roofs. The material, which comprises laminated layers of boards (typically softwood), derives its stiffness and dimensional stability from the alternating grain direction between layers. The timing of the studio course coincided with the release of the U.S. CLT Handbook, a design guide culminating from performance-based testing by FP Innovations (Douglas, et al. 2013). Seizing the opportunity to introduce massive timber to 33 student designers while examining and applying the design guidelines outlined in the Handbook, we asked students to utilize prefabricated CLT panels as the primary structural material in their proposals. The size and unitization (200 units) of the project program provided an ideal test application for CLT and the new guide.



Figure 2: CLT material study from “treaty oak” project. Source: (Barrett and Martin 2013)

1.3. Collaborative structure

The Comprehensive Studio course requires M.Arch students in their final semester to develop and document rigorous design solutions to a complex project. The project combines an exploration of the intuitive, poetic, and humane aspects of architecture with a thorough integration of building systems and other technical and functional considerations. Students work in pairs for the duration of the semester, and they are typically divided into distinct sections, each directed by individual faculty members.

However, in the case of the 2013 Comprehensive Studio, the teaching faculty decided to keep the 16 student teams together and instruct them through rotating consultations. This arrangement allowed each student to benefit routinely from the wider spectrum of knowledge offered by the diverse instructors, whose complementary areas of expertise included: affordable, zero-energy housing; architectural history + theory; and structural systems + advanced timber technologies. The latter of these instructors attended the first American CLT Symposium⁴ early in the semester and returned with expanded knowledge in the areas of acoustical and fire performance, as well as new case studies.

The 2013 Studio also operated in close collaboration with a group of three Civil Engineering students and their faculty advisor, who were simultaneously engaged in studying CLT in their own Directed Studies course. Following the initial site analysis and concept-forming stages, these project consultants spent time each week with the student design teams. They evaluated the working drawings and made recommendations for panel sizes and span directions. They discussed shear wall configurations and evaluated size and placement of framed openings. They also worked with certain teams to develop hybrid solutions, combining steel, concrete, or glulam members where necessary. In conjunction with the consultation received, the design teams were expected to clearly articulate the load paths of their CLT structures, and were asked to produce detailed structural diagrams and assembly drawings. In return, the consulting engineering students received 16 unique and challenging case-study designs for which to run analysis and calculations. They developed for themselves a strong understanding of the material capabilities and limitations of CLT, and identified areas for future research, including the testing of Southern Pine panels and the potential for longer-span solutions. Most importantly, both sets of students were necessarily involved in the types of collaborative, problem-solving conversations that they would expect from their future professional practices.

Additional support was provided to both sets of students by Crawford Murphy (architect) and Frank Ungert, PE, both professionals in our area with experience designing and building with CLT. Murphy and Ungert opened the semester with a detailed presentation concerning CLT, its production, and its advantages for rapid on-site construction. They compared the weight of CLT (25-37 lbs/ft³) to normal-weight precast concrete (150 lbs/ft³) and described the resulting opportunity for foundations of reduced size (Douglas, et al. 2013). They also echoed the life-cycle benefits and carbon sequestration being touted by CLT advocates in the softwood lumber industry. Following the presentation, Murphy continued to be involved as an industry resource and guest reviewer for the remainder of the semester.

2.0 PRE-DESIGN

2.1. Market analysis and site selections

Working with the University’s planning department, the studio faculty identified four diverse sites on or near the campus that were most suitable for a future graduate and married-student housing program. Each student team then performed detailed site and market analyses, including a close critical inspection of the University’s most recent housing survey, prior to selecting a site for development. Students recognized that the University’s earlier studies of economic viability had been based on fairly narrow market assumptions,

namely that graduate and married students required the same square footages and specific amenities offered by off-campus competitors. Each team re-examined the survey data through the lens of the given sites. Rather than trying to compete with the amenities established by private developments, students focused on the unique and positive opportunities associated with the sites themselves – from outdoor recreation to campus connectivity, and from quiet settings to the potential for creative LIVE / LEARN programming (e.g. Fig. 3). For example, would graduate students be content with a smaller bedroom and shared laundry facilities if, in return, they were able to walk to and from class, share a community garden, and have on-site day-care for their children? Since the course was comprised of graduate students (many with families), the Studio served as an ideal testing ground for the various programming and lifestyle proposals. In this sense, design and market assessment were linked seamlessly and performed in parallel.

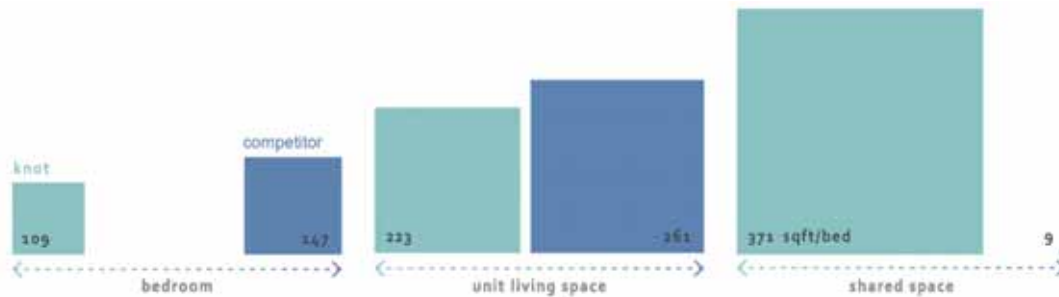

Figure 3: Space allocation comparison from “knot” project. Source: (Atria and Kim 2013)

2.2. Program and code assumptions

In keeping with the ideal size and scope identified by the university’s housing department, the project program required housing for approximately 300 students and family members in up to 200 dwelling units. The division of single bedroom versus multi-bedroom units was left up to each student team and derived from their own demographic assessment (e.g. Fig. 4). The assignment also required students to propose and design some form of on-site mixed-use programming. Proposals ranged from daycare facilities, to cafés, to support spaces for outdoor recreation programs.

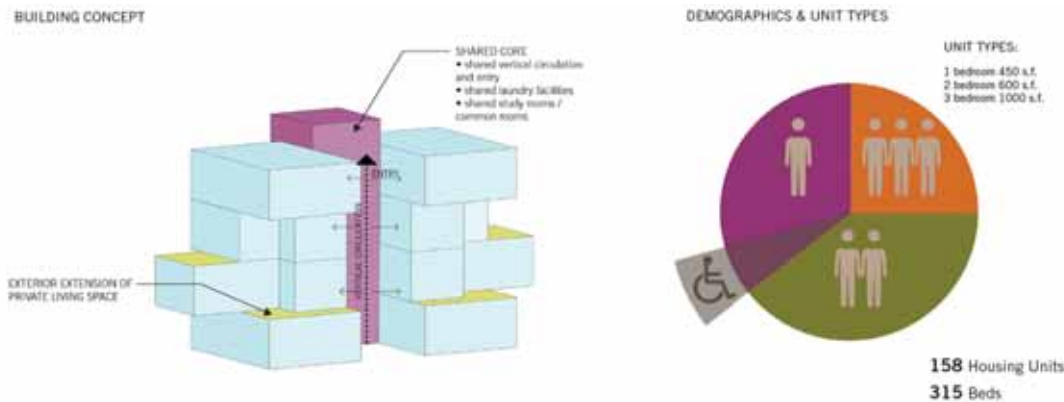

Figure 4: Program organization from “spectrum” project. Source: (Knorr and Yarborough 2013)

For the purpose of the project, the Studio assumed an R-2 residential occupancy and Type III construction based on the definitions outlined in the 2012 International Building Code. More recent advances in North American testing and documentation have led to direct recognition of CLT in the forthcoming 2015 IBC, wherein it will be accepted for Type IV (heavy timber) construction. However, at the time of the 2013 Studio, the assumption of a Type III A classification made the most sense, given the co-assumptions that the University would require sprinkler systems and that CLT exterior walls would perform comparably with fire-retardant-treated lumber. This meant that the students faced a maximum building height of five stories with a possible increase to six stories if using a non-combustible podium at the ground floor, a strategy that is widely employed in wood-framed structures.

3.0 PROJECT DEVELOPMENT

3.1. Load paths and panel capacities

Taking advantage of the complimentary areas of expertise at work in the Studio, systematic and integrative project development was conducted over the course of the semester, including efficient unit plans, thorough structural and mechanical schemes, rigorous sustainability strategies, and detailed construction / assembly drawings. All of this while being careful to carry forward the initial concepts about lifestyle and the potential programmatic advantages associated with campus living (e.g. Fig. 5).



Figure 5: Floor plans and smart-wall concept from “knot” project. Source: (Atria and Kim 2013)

Through their discussions with the consulting engineers, the Studio grew to recognize the formal potential of stiff, lightweight wall panels, which can act as deep beams in cantilevering scenarios. As a result, some proposals explored overhanging and projecting volumes and their associated details (e.g. Fig. 6).

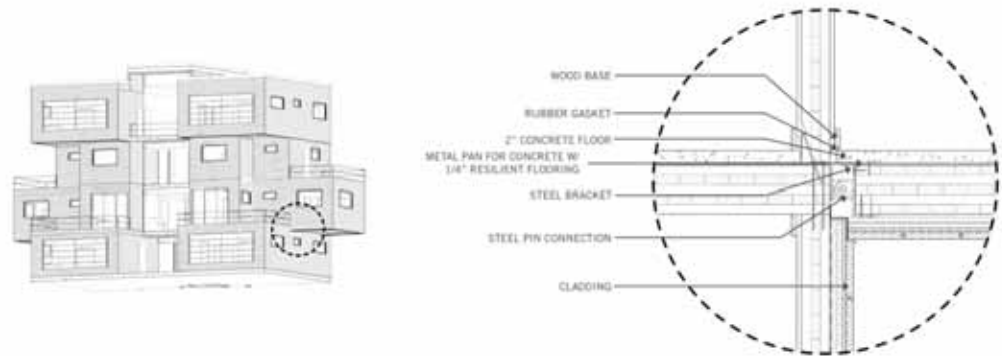

Figure 6: Cantilevered room detail from “spectrum” project. Source: (Knorr and Yarborough 2013)

Other students were confronted with the span limitations of CLT floors and roofs, and were thus required to include additional supporting elements such as steel or glulam beams and occasional columns in order to achieve the openness they desired in the living spaces (e.g. Fig. 7). These extra elements, and the time and complexity they add to construction, introduced the need for an all-in-one, long-span alternative – a concept that would be revisited in later studies (see section 4.1).



Figure 7: Load Paths and panel sizing from “seed” project. Source: (Boulier and Boykin 2013)

3.2. Acoustical design

Acoustical considerations presented another design challenge to the students. The IBC requires a minimum Sound Transmission Class (STC) rating of 50 for walls and floors between dwelling units, as well as a minimum Impact Insulation Class (IIC) rating of 50 for floors. However, according to the CLT Handbook, bare CLT floors and walls fall well short of these requirements, particularly in their IIC measurements. The actual STC rating measures from 32 to 34 for 3-ply walls and 39 for 5-ply floors, while the actual IIC measures from 23 to 24 for 5-ply floors (Douglas, et al. 2013, 9.13). Thus, sound dampening measures need to be employed for floors and walls between units. Working from tested assemblies presented in the Handbook, as well as various other case studies, the students proposed detailed sound attenuation strategies using furred-out walls, raised floors, and dropped ceilings (e.g. Fig. 8). Each of these scenarios necessarily add time and expense to construction.

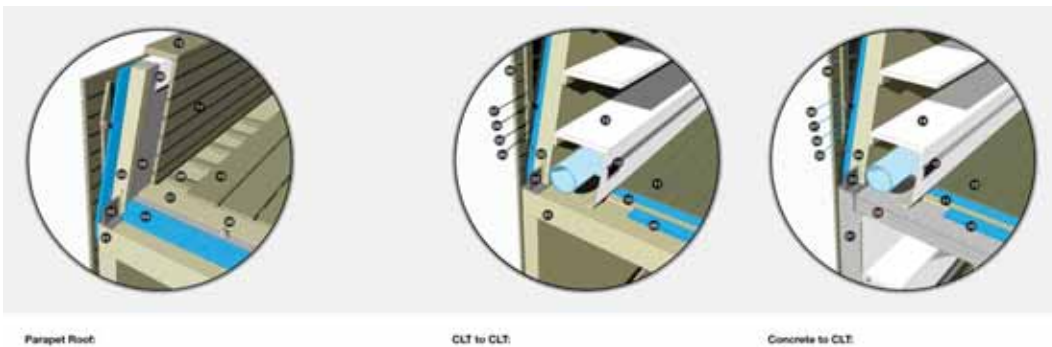

Figure 8: CLT details and acoustical floor treatment from “treaty oak” project. Source: (Barrett and Martin 2013)

4.0 FOLLOW-UP RESEARCH

4.1. Hollow-massive timber panels

As a direct extension of his work with the Studio, Graham Montgomery, one of the collaborating Engineering students, opted to study long-span alternatives to standard CLT as the subject of his subsequent master’s thesis, funded by the USDA (Montgomery 2014). In his report, Montgomery explains that increasing CLT panel thickness beyond five plies may achieve moderately longer spans but not without diminishing returns on investment. Thus, the practical limitation on CLT floor spans is around 7.6m (25ft), a figure that is consistent with the earlier calculations he had provided to the design teams in the Studio.

For a long-span alternative, Montgomery proposes a built-up hollow massive timber (HMT) panel constructed from three-ply CLT flanges and glulam web members at 81.28cm (32in) on-center. An unbalanced orientation of the boards in the flanges was ultimately selected to optimize bending strength and stiffness (e.g. Fig. 9). It was also predicted that this configuration would be most resistant to fire damage due to the increased protection of the critical perpendicular-to-span layers.⁵ Grade #2 Southern Pine was used for the parallel-to-span layers of the flanges, while Grade #3 Southern Pine was used for the perpendicular layers.



Figure 9: Long-span hmt panel. source: (montgomery, et al. 2014)

The voids in the HMT cross-section provide three primary benefits and one considerable challenge. First, there is the obvious economization of material and conservation of weight. Second, they provide space for the potential integration of MEP systems. Third, they improve acoustical performance with respect to solid CLT panels. The challenge would come in demonstrating adequate fire performance and redefining the notion of “enclosed spaces” which are prohibited for Type IV construction by the IBC. It is our contention that glulam end blocking would effectively seal the voids and limit oxygen. This, in combination with the slow char rate of all of the constituent components, would make the spread of fire highly improbable.

A combination of analytical modelling and physical shear testing was employed to examine two primary forms of connecting the webs to the flanges: structural adhesives and inclined self-tapping screws. Both forms of connection were shown to deliver adequate design values for shear, bending, and vibration in panels spanning beyond 9m (30ft). Montgomery concludes that an emulsion polymer isocyanate (EPI) glue bond offers the greatest economy and constructability, but that the screw connection could be used in cases where removable flanges are desirable, such as areas for accessing MEP systems. The screw connection would also be required if acoustic membranes are utilized between the web and top flange to dampen impact noise and improve the IIC rating.

Additional physical testing needs to be performed with full-scale HMT panels. Also, detailed acoustic testing will be necessary to quantify the enhanced acoustic performance, which, if substantial, may negate the need for sound-attenuating drop-ceilings and/or raised floors. Finally, more fire testing is needed for assessing an accurate fire rating for HMT panels, including the glue bonds, and for evaluating the effectiveness of sealed and/or insulated void spaces. That being said, Montgomery’s work represents a clear first step in addressing research questions raised through the initial Studio project.

CONCLUSION

In conclusion, the 2013 Comprehensive Studio described in this paper proved to be successful and impactful in at least three significant ways. First, the unique interdisciplinary collaboration between students of architecture and students of engineering was especially effective in combination with the focus on a particular structural material and system. A more recent version of this collaborative arrangement was employed in the spring of 2014, and, while it successfully established a working dialogue between the disciplines, it lacked the clarity and sense of discovery that accompany a singular, well-defined, and shared research topic, such as CLT utilization. Likewise, the fact that the 2013 engineering students were simultaneously engaged in their own independent CLT research proved critical to their optimal, fully-invested consultation in the studio.

Second, the participating students and faculty came away with a much-expanded understanding of CLT, an emerging building material in North America. The repetition in the project program and the appeal of faster construction presented an ideal application of CLT and a platform for studying its capabilities and its constraints. At minimum, each student left prepared to participate in the expanding conversation surrounding CLT, a material whose emergence in North America depends on informed architects and engineers.

Finally, the Studio served as a model project for the University’s Wood Utilization + Design Institute and became a springboard for ongoing funded research related to CLT and massive timber. With further testing, the HMT panels described above may eventually offer an all-wood, long-span floor system that is compatible with the tall timber structures currently being proposed and developed around the world.⁶

ACKNOWLEDGEMENTS

I would like to acknowledge Ulrike Heine and Ufuk Ersoy, PhD, my co-instructors for this course, as well as Scott Schiff, PhD, our collaborating partner in Civil Engineering.

REFERENCES

- Atria, Josh, and Minji Kim. 2013. *Knot: Graduate Student Housing*. Clemson, SC: Clemson University School of Architecture.
- Barrett, Nick, and Joseph Martin, 2013. *Treaty Oak*. Clemson, SC: Clemson University School of Architecture
- Boulier, Lauren, and Laura Boykin, 2013. *SEED*. Clemson, SC: Clemson University School of Architecture.
- Douglas, Brad, and Erol Karacabeyli, editors, 2005. *CLT Handbook, U.S. Edition*. Pointe-Claire, Quebec: FP Innovations.
- International Code Council. 2011. *2012 International Building Code*. Birmingham, AL: ICC.
- Knorr, Julie, and Lindsay Yarborough, 2013. *Spectrum: A Unique Campus Neighborhood Experience*. Clemson, SC: Clemson University School of Architecture.
- Montgomery, Graham. 2014 "Hollow Massive Timber Panels: A High-Performance, Long-Span Alternative to Cross Laminated Timber" (master's thesis, Clemson University, 2014).
- Montgomery, Graham, Scott Schiff, and Weichiang Pang. "Hollow Massive Timber Panels: A High-Performance, Long-Span Alternative to Cross Laminated Timber" (paper presented at the World Conference on Timber Engineering, Quebec City, Quebec, August 10-14, 2014).
- "The State of South Carolina's Forests," accessed November 28, 2014, <http://www.state.sc.us/forest/stateofsc.pdf>.

ENDNOTES

- ¹ The primary course instructors were: Dustin Albright, Assistant Professor of Architecture; Ufuk Ersoy, PhD, Assistant Professor of Architecture; and Ulrike Heine, Associate Professor of Architecture.
- ² The collaborating instructor was Scott Schiff, PhD, Professor of Civil Engineering.
- ³ The University Housing advisor was Gary Gaulin, Associate Director of Sustainability.
- ⁴ The US CLT Symposium, sponsored by WoodWorks, was held on February 28, 2013 in Seattle, WA.
- ⁵ Detailed fire testing is on-going as of the time of writing.
- ⁶ The groundswell of interest in sustainable, massive timber construction is being demonstrated in the recent proliferation of tall timber proposals such as the Wood Innovation and Design Centre by Michael Green Architecture in British Columbia, the Timber Tower Research Project by Skidmore Owings and Merrill in Chicago, and the Västerbroplan Residential Tower by C.F. Moller in Stockholm, among others.

Research-based design as translational research between the academy and practice

Corey T. Griffin¹

¹Portland State University, Portland, OR

ABSTRACT: Research-based design uses quantitative data collected from existing buildings, generated through rapid prototyping and testing, or simulated using parametric and genetic computer modeling to reduce resource consumption through improved design. This methodology has been validated in the widespread adoption of “evidence-based design” to improve patient outcomes in healthcare facilities. Outlining several models for aligning academic architectural research with the needs of practice, this paper focuses on the advantages and challenges in using graduate-level building science coursework as vehicle for translational research. The term translational research is borrowed from medicine and refers to taking current laboratory research and tools and applying them to practice. In 2012 and 2013, faculty members in the School of Architecture at Portland State University were awarded the largest NCARB grant at that time to generate translational building science research in collaboration with local architecture firms. This grant, along with the resources of an existing research lab focused on green buildings, transformed traditional lecture-based building science and technology courses into a series of on-going, graduate level seminars that revolve around two primary activities: (1) architecture and engineering students conduct building science research of relevance to a project currently under design in a firm and (2) students are embedded in project teams where they attend all interdisciplinary meetings for the course of a term to witness and document interdisciplinary collaboration. This paper highlights the lessons learned from these pilot seminars, including what types of research projects have been most fruitful for the students and practitioners, and how these courses could be a model for building science education elsewhere.

KEYWORDS: Research-Based Design, Translational Research

INTRODUCTION

The operation of buildings consumes 41 percent of the primary energy and is responsible for 40 percent of carbon dioxide emissions in the US (US DOE 2011). These numbers exclude the significant environmental impact of manufacturing, transporting, installing, maintaining and eventually demolishing materials used in building construction (Ramesh et al. 2010). While every other sector has been reducing energy use and carbon emissions over the last 30 years, commercial buildings have increased their energy intensity (energy use per square foot) by over 8%. Furthermore, the total square footage of these buildings has increased by almost 60% over the same time period. Only the recent recession temporarily blunted what had been the continual growth in energy use by the building sector (US DOE 2011). To meet ambitious and in some cases legislated goals to create net-zero energy buildings by 2030 or 2050 (Architecture 2030 2012, US Congress 2007), there is clearly a national need for future architecture professionals to be well-educated and skilled in building science.

Green building is defined by the EPA as “the practice of creating structures and using processes that are environmentally responsible and resource-efficient throughout a building's life-cycle” (US EPA 2013). Current green building practice relies heavily on rating systems to set goals and define strategies (Klotz et al. 2010). Unfortunately, a study of the energy intensity of 150 certified green buildings showed these buildings varied greatly compared to the average for the USA's existing commercial building stock; with some much higher, some the same and some lower (Turner & Frankel 2008, Newsham 2009, Scofield 2009). To improve this situation, this paper argues for a robust research-based STEM education for engineers and architects centered on building science, called building physics or building engineering physics in Europe. Decisions made early in the design process have the most significant impact on a building's resource use (Magent 2009). These decisions should be based on robust scientific and engineering knowledge and research rather than poorly constrained rating systems or rules of thumb. Research-based design allows for a more rapid integration of green building strategies, materials and systems by conducting university-led laboratory simulations or post-occupancy analysis of innovative buildings and applying this research to projects currently under design through collaboration with professional practitioners.

Interdisciplinary collaboration between engineers and architects during the design and construction of a building is also critical to the reduction of energy use and carbon emissions of green buildings (Griffin et al., 2010, Klotz et al., 2009, Kibert 2008). However, currently there is little, if any, interaction between architecture and engineering students during their education and a number of barriers to interdisciplinary

courses and programs in academia (Simpson et al., 2009, Little 1999). Green building “charrettes,” collaborative meetings of stakeholders early in the design process to discuss engineering and design strategies to reduce resource use, are common in professional practice. However, numerous barriers between participants of different disciplines, including disparate value systems and terminology, limit the efficacy of these charrettes (Hoffman and Henn 2008). As members of the building industry are highly influenced by their early training, one way to overcome these barriers is by offering opportunities for engineering and architecture students to take building science courses in other disciplines and have meaningful and substantive experiences together during their education. This will allow individuals to better understand the language, motivations and biases of each discipline in order to become more effective collaborators in the future. The Royal Academy of Engineering recently released a report (King 2010) arguing for the urgent transformation of engineering education to emphasize multi-disciplinary research in building design, engineering, energy and carbon efficiency and the need to recruit the best engineers of each generation to reduce the environmental impact of buildings. In 2002, Architect Ed Mazaria launched the 2030 Challenge with the mission “to rapidly transform the built environment from the major contributor of greenhouse gas (GHG) emissions to a central part of the solution to the climate and energy crises (Architecture 2030 2012).” This included the 2010 Imperative to transform architectural education toward designs that eliminate the need for fossil fuels and a renewed focus on building science.

1.0 EXISTING MODELS

1.1. Evidence-based design

Evidence-based design is a process for the conscientious, explicit, and judicious use of current best evidence from research and practice in making critical decisions, together with an informed client, about the design of each individual and unique project (Hamilton and Watkins 2009, 9).

As Ulrich (2006) highlights, there have been over 700 studies published in medical journals linking the design of healthcare facilities to the health of patients and staff: “Much credible evidence now shows that good design of a hospital’s physical environment promotes better clinical outcomes, increases safety, and reduces stress for both patients and staff.” This data provides healthcare designers with the ability to improve future hospitals. There have been several recent books published on evidence-based design exploring the role research can play in improving the performance of buildings besides healthcare (Hamilton and Watkins 2009, Chong et al. 2010, Kopec et al. 2011). While the benefits of this approach are clear, the path to using more evidence-based design in practice is stymied by a lack of knowledge about research methods and requires educational reforms: “Hopefully, the profession will make clear to our educational system that we demand some level of research knowledge as part of basic design education, because it will be as important to our professional success as design and technical capability (Chong et al. 2010).”

There are two major, interdisciplinary university centers for evidence-based design focused on healthcare: the Center for Health Systems and Design at Texas A&M and the PhD Concentration in Evidence-Based Design in the School of Architecture at Georgia Tech. Although focused exclusively on healthcare design, Georgia Tech’s SimTigrate Design Lab combines post-occupancy data and simulations to generate data in collaboration with professional practice to improve the design of buildings. In the case of the SimTigrate Design Lab, the improvements would include fewer falls in a hospital, whereas the translational research discussed in this paper will use similar tactics but focus on reducing the environmental impact of buildings.

1.2. Research-based design

As the term *evidence-based design* has been largely coopted by the healthcare researchers and focuses on human-centered outcomes (reducing patient recovery times, increasing staff well-being, lowering stress), this project prefers the term *research-based design* to refer to a similar data-driven design process that focuses on reducing the environmental impact of buildings. Two other groups that have pursued work comparable to the Research-based Design Initiative (RBDI) model discussed in this paper include the Vital Signs project at UC Berkeley, 1995-2000, (Benton and Kwok 1994, Kwok, et al. 1998) and the Agents of Change project at the University of Oregon, 2000-2005 (Kwok, et al. 2005). Both projects focused on incorporating quantitative, research-based exercises into building science coursework to train future architects “to create buildings that provide for human health and well-being while using energy responsibly” as well as providing training to architecture faculty across the US. These projects differ from the RBDI at the author’s university in three ways: (1) the RBDI is interdisciplinary with students from engineering and architecture taking courses and collaborating on research together, (2) the RBDI engages professional practitioners to develop research questions and mentor students, and (3) Vital Signs and Agents of Change focused solely on understanding how existing buildings were working without applying the research to the design of new buildings and without the use of simulation software now available to supplement in-situ data collection.

1.3. University-housed research consortium

The West Coast of the US is fortunate to have several models for research-based design centers and laboratories at universities that focus on reducing the environmental impact of buildings. These centers have multiple funding sources, but the primary support comes from utilities wanting to promote energy efficiency. The Center for the Built Environment (CBE) at the University of California, Berkeley is “a place where prominent industry leaders and internationally recognized researchers cooperate to produce substantial, holistic, and far-sighted research on buildings.” The work of the CBE is driven by consortium of industry partners and focuses on longer term, non-project specific research into promising technologies for buildings as well as the largest database of post-occupancy evaluations for buildings in the US. While faculty members in the CBE teach building science courses, students in those courses do not have access to the equipment and resources of the CBE and do not work with the industry partners on research.



Figure 1: Building science research consortium organizational diagram. Source: Author

This model has advantages in generating longer-term, high quality research as the consortium pools funding to focus on a collective research goal. The professional partners have access to research and tools that have already been developed. One draw back to this model is that individual firms have less control over directing the research agenda. The consortium model cannot fulfill more immediate research needs that may be driven by a particular building under design.

1.4. University as consultant

Supported by BetterBricks – the commercial building initiative of the Northwest Energy Efficiency Alliance – and electric utilities throughout the Northwest, Integrated Design Labs (IDL) and the Energy Studies in Buildings Laboratories (ESBL) form a network of labs providing design assistance to architecture firms to reduce electricity use. As the utilities are focused on energy efficiency to reduce the need for building new electrical power plants, these labs typically focus on two topics – reducing electric lighting through the use of daylight and natural ventilation to reduce the size and need for mechanical ventilation – and act as building science consultant to architecture firms on specific projects under design. The equipment in these labs is centered on simulation. Like the CBE, the primary mission of BetterBricks is serving industry and not teaching building science. These labs are also housed in Schools of Architecture and not interdisciplinary. To varying degrees at the different labs in the network, students have limited access to the equipment in these labs and no part of the research conducted for architecture firms unless employed as graduate research assistants (GRAs) in the lab.

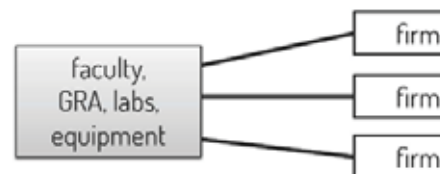

Figure 2: University as building science consultant organizational diagram. Source: Author

The advantages of this model include high quality research that is timed and directly applicable to improve buildings currently under design. Some shortcomings include having research topics and design assistance determined by the funding agency – typically a utility. Increasingly these funders require measurable results, which can be difficult to attain without further funding. The largest drawbacks of this model are that firms do not have access to previous research and the limited sharing of research between firms.

2.0 TRANSLATIONAL RESEARCH PRACTICUM

In short, there is no initiative or lab in existence at a university on the West Coast of the US that has the same aims as the RBDI to support the interdisciplinary teaching of building science through hands-on research in collaboration with industry. Donfrio (2013) has outlined the need for translational research as well as three models for collaboration between the academy and practice. The RBDI does not fit neatly in one of the categories defined by Donfrio and instead combines aspects of “the academy embedded in practice” and “collaboration” models as described below.

2.1. Overview

Even at universities with both architecture and engineering programs, there are limited opportunities in the academic setting for cross-listed, interdisciplinary courses where students would engage each other in meaningful ways to prepare them for practice. At the same time, there is a demand in practice for research-

based design to optimize resource use and building performance. Unfortunately, most practices do not have the resources to conduct time-intensive research.

To address both of these issues, Assistant Professor Corey Griffin and Professor Sergio Palleroni transformed traditional building technology courses into a series of ongoing, graduate level seminars that revolve around two primary activities: (1) embed architecture students in project teams where they attend all interdisciplinary meetings for the course of a term to witness and document interdisciplinary collaboration and (2) have architecture students lead a multidisciplinary team of students in a sustainability research endeavor of relevance to the project team they are tracking. In this unique way, students become contributing members of a design team and building science experts on issues relevant to current practice. For the architecture firms involved, working with universities allows practicing architects the ability to utilize a deeper level of research expertise in the design process and access resources not typically available in practice. One of the most exciting outcomes of this collaboration have been the semi-annual research symposiums where students present their work to representatives from all of the participating firms, creating a dialog around pressing building science issues with students, faculty and practitioners.

Two graduate level building science and technology seminars were reoriented from lecture and case study based into practice and research oriented courses to ensure our students will be effective collaborators and leaders as part of multidisciplinary teams when they enter practice. The faculty instructors of these courses, continued to ensure students are given the content required to meet NAAB and departmental standards, the outcomes and deliverables of the course will shift to focus on multidisciplinary collaboration and original sustainability research relevant to practice. Advanced Building Structures, an elective seminar, was the first pilot for this new methodology in Winter 2012. Advanced Building Technology, a required course for entering M.Arch. students, and Advanced Building Structures expanded these efforts in Fall 2012 and Winter 2013.

To expose architecture students to various models for multidisciplinary collaboration, they were embedded in professional design teams in the midst of conceptual, schematic or early design development. A practitioner or group of practitioners at each firm identified one or more projects that align with one of our ten-week terms. They were responsible for meeting with the student(s) regularly and ensuring they are included in all multidisciplinary meetings and witness to other forms of interdisciplinary communication (e-mails, conference calls, etc.). Students documented this collaboration in the form of weekly memos that were shared with the rest of the seminar. These memos were used to construct a graphic timeline at the end of the course documenting when and how various disciplines interfaced over the course of ten weeks and the results of those collaborations in terms of design decisions made and issues resolved.

To provide architecture students with the opportunity to lead an interdisciplinary team of peers, students generated original sustainability research relevant to the firms and project team of which they are a part. The practitioners in consultation with faculty will select the research topics. As these seminars were promoted in both the mechanical and structural engineering departments, architecture students led teams of students from multiple disciplines in conducting the research.

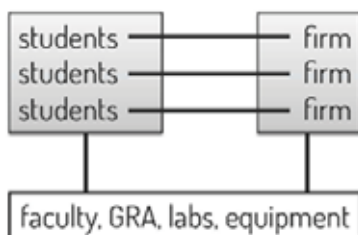

Figure 3: Building science research practicum organizational diagram. Source: Author

The advantages of this model is that all graduate students at Portland State University (PSU) are involved and trained with research skills relevant to professional practice – not just GRAs who happen to work in a lab. The research is conducted both at the university as well as in the firms, with students having the opportunity to have a space in their firm’s office. The students have direct contact with practitioners with faculty, a GRA and labs supporting the research. Individual firms determine the research projects and topics that can be related to a project under design or not depending on the timing of the academic term and project schedules. The research is shared between firms through end of term symposiums and dissemination on the RBDI website. Three major drawbacks are that the project scope is determined by the length of an academic term, the quality of the research is dependent on the student(s) assigned to the project and coordination of over twenty graduate students and five firms – each with multiple research projects – can be challenging.

2.2. Research conducted

A total of 35 students took one of the three seminars sponsored by the NCARB grant and worked with over 20 practitioners from five architecture firms in Portland, Oregon. These firms included BOORA Architects, THA Architecture, SRG Partnership, YGH Architecture, and ZGF Architects, four of which were on the 2013 Architect magazine Top 50 list. Depending on the firms' interests and buildings under design during a given term, a wide range of research projects were conducted. The research projects can be categorized into five major categories: building envelopes, structural systems, daylighting/solar gain, ventilation (natural and displacement), and building retrofits. Some projects used tools from PSU's Green Building Research Laboratory to conduct post-occupancy assessments to measure the efficacy of replacement windows while others used simulation software to model daylight and natural ventilation for building under design. Students both wrote a research paper and create a research poster to disseminate their results.

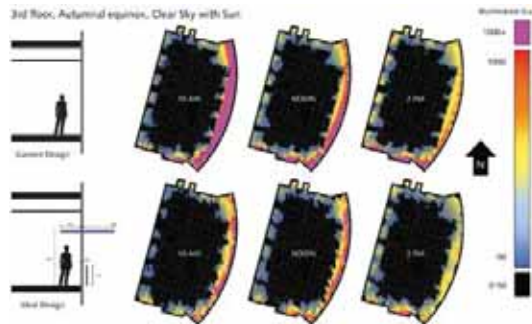

Figure 4: Image from student research poster focus on shading device design and illuminance. Source: Ben Deines

The greatest challenge faced was constructing research projects that could be accomplished in the ten-week terms at PSU. Many of the firms involved had little to no experience constructing building science research questions or experiments, and it required both meetings between faculty and practitioners as well as trial and error during the seminars to develop successful research projects. The most successful projects were one's that students could start in the required Fall course and continue in the Winter term elective. These students learned how to use new tools and simulations in the first class, often completing a proof of concept or single iteration, and then could deploy them to answer more complex questions in the second course.

2.3. Evaluation

The initial objects for the project are below, followed by an assessment of how they have been achieved to date. All of the student and non-faculty architect practitioners (including practitioners outside of the five main sponsors) who participated in at least one of the seminars sponsored by this grant were sent an evaluation survey (see appendix). Sixteen students and eleven practitioners responded to the survey, which included questions about how well each of the three goals for this project was met on a scale of one (not met) to five (very well met).

Goal One: Expose architecture students to various models for multidisciplinary collaboration by embedding them in professional design teams.

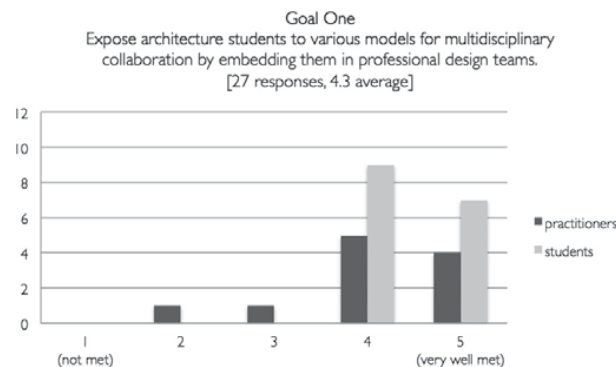

Figure 5: Student and practitioner evaluation responses to Goal One. Source: Author

Over the course of three pilot seminars, students worked on 12 research projects while embedded with professional design teams at five Portland firms. The students commented in their course evaluations that

observing and participating on design teams was “enlightening” and one of the best parts of the course. This sentiment is reflected in the survey data above. During seminars students discussed the types of interaction they witnessed and documented between practitioners from different disciplines. Weekly collaboration memos and a final timeline were used to document this.

Goal Two: Provide architecture students with the opportunity to lead an interdisciplinary team of peers.

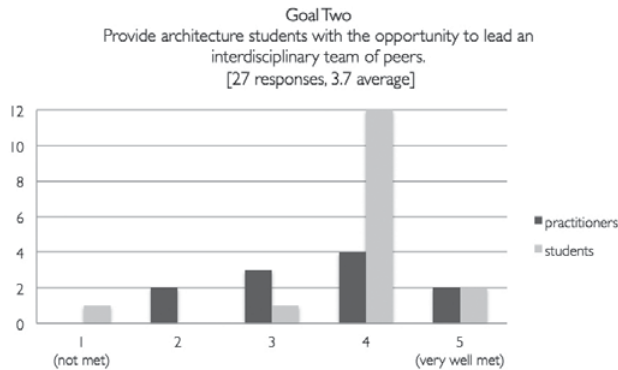

Figure 6: Student and practitioner evaluation responses to Goal Two. Source: Author

This goal was the least met of the three, but still achieved some measure of success as based on the survey results above. There was not enough time between the announcement of the grant (November 2011) and the beginning of Winter term (January 2012) to recruit students from other disciplines. While meetings were held with faculty from engineering departments to recruit engineering students and publicity materials were distributed to help with this recruiting, only one civil engineering student and two mechanical engineering student participated throughout the three seminars (with only one enrolled in the seminar), so only three teams were able to work with an engineering student. However, many of the students were able to interface with practicing engineers who were on the project teams they were tracking as well as work with engineering students who run laboratories. In many cases these engineers and lab assistants also assisted with the research projects. Two major barrier to including more engineering students in these seminars are that (1) students pay for each credit hour they take at PSU so there is a financial disincentive to take more elective courses or courses outside of your discipline and (2) faculty members in other disciplines, who advise students, need to know about these courses and the value they hold for engineering students.

Goal three: Generate original sustainability research to assist practice with pressing needs and improve the public health and welfare.

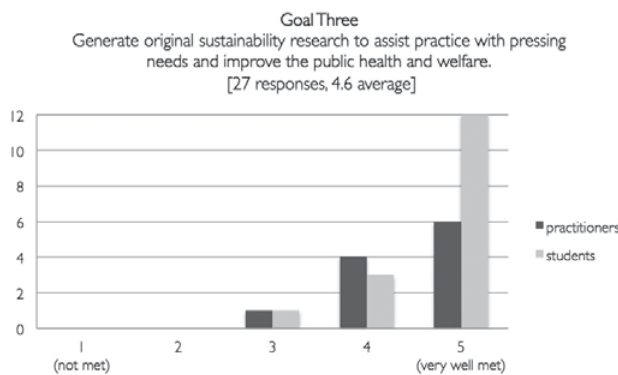

Figure 7: Student and practitioner evaluation responses to Goal Three. Source: Author

All three seminars were highly successful in meeting this goal. All of the non-faculty architect practitioners stated that the research the students presented at the end of the pilot course exceeded their expectations. Five students (or teams of students) have had their research papers from the pilot course accepted at an international conference in Portugal this summer. Equipment from the Green Building Research Laboratory is offering an opportunity for firms to engage in research that they otherwise might not have been able to do. It also provides training of students in these metrics and means of measuring environmental impact or performance.

CONCLUSION

The overall success in integrating practice and the academy to conduct translational sustainability research was excellent. Students in the courses worked closely with the practitioners, other architects in their office, and professional engineers on their research projects, meeting at least every other week outside of the seminar. All of the graduate research symposiums held at the end of each course were well attended by over a dozen practicing architects to hear and discuss the final results of the research. Most teams of students were invited to present their research findings to the entire firm that they were working with or to the design team in which they were embedded. The survey of students and practitioners at the end of the one-year grant showed that the goals of the project were “well met” and both groups thought the seminars were a “win-win” for all parties involved. This is best summarized by Miguel Hidalgo, project architect at BOORA Architects (and previously of THA and YGH), who wrote the following in his evaluation of the program:

Throughout my involvement with the PSU Research-based Design Initiative I have been struck by the unique opportunities it offers to students to directly engage in active projects and offer actionable feedback that can impact the final project designs. For firms, the Research-based Design Initiative provides access to engaged and motivated students who can dig into issues that the design team may not have the personnel resources to fully explore. It also is an opportunity for firms that ask questions that may be tangential to project completion—new tools, new process—but can inform later work.

Due to the success of the pilot seminars, another grant for \$100,000 from the Oregon Community Foundation's Van Evera and Janet M. Bailey Fund was secured which will continue to support these graduate seminars through 2018. These types of practicum courses that focus on translational research are a model for improving building science education and practice throughout the US.

ACKNOWLEDGEMENTS

The author would like to thank NCARB for their funding of the pilot seminars discussed in this paper, and Green Building Research Laboratory at PSU for providing research equipment used in the RBDI. The author would also like to thank the architecture firms that have participated in the RBDI, including BOORA Architects, THA Architecture, SRG Partnership, YGH Architecture, and ZGF Architects.

REFERENCES

- Architecture 2030. 2012. *The 2030 Challenge*. Available at:
http://architecture2030.org/2030_challenge/adopters_govt_local [Accessed 06 August 2013]
- Benton, C. C., & Kwok, A. 1994. Field Methods for Architectural Curricula: The Vital Signs Project. In *Proceedings of the National Passive Solar Conference* (Vol. 19, pp. 409-409).
- Chong, G. H., Brandt, R., & Martin, W. M. 2010. *Design informed: driving innovation with evidence-based design*. John Wiley & Sons.
- Donfrio, M. 2013. Building Knowledge: A Framework for a Translational Research Culture in Architecture. In: *Proceedings of ARCC 2013*, Charlotte, NC, March 20-27, 2013. pp. 12-17.
- Griffin, C.T., Knowles, C., Theodoropoulos, C., and Allen, J. 2010. Barriers to the implementation of sustainable structural materials in green buildings. In: Cruz P, editor. *Structures and Architecture: Proceedings of the 1st International Conference on Structures & Architecture (ICSA2010)*. Guimarães, Portugal, 21-23 July 2010. pp. 1315-1323.
- Hamilton, D. K., & Watkins, D. H. 2009. *Evidence-based design for multiple building types*. John Wiley & Sons.
- Hoffman, A. and Rebecca Henn, R. 2008. Overcoming the Social and Psychological Barriers to Green Building. *Organization & Environment*, 21: 390-419.
- Little, R.G. 1999. Educating the Infrastructure Professional: A New Curriculum for a New Discipline. *Public Works Management Policy* 1999 4: 93.
- Kibert, Charles J. 2008. *Sustainable construction green building design and delivery*. Hoboken, N.J.: John Wiley & Sons.
- King, D. 2010. Engineering a low carbon built environment: The discipline of Building Engineering Physics. London: The Royal Academy of Engineering. Available at:
http://www.raeng.org.uk/education/vps/pdf/Engineering_a_low_carbon_built_environment.pdf [Accessed 01 August 2012]
- Klotz, L., Horman, M., Riley, D., and Bechtel, J. 2009. Process Transparency for Sustainable Building Delivery. *International Journal of Sustainable Engineering* 2 (4): 298.
- Klotz, L., Mack, D., Klapthor, B., Tunstall, C., and Harrison, J., 2010. Unintended anchors: Building rating systems and energy performance goals for U.S. buildings. *Energy Policy* 38 (7): 3557-3566.
- Kopec, D., Sinclair, E., & Matthes, B. 2011. *Evidence based design: A process for research and writing*. Pearson Higher Ed.

- Kwok, A. G., Benton, C. C., & Burke, B. 1998. Research Inspired by Design: the Vital Signs Project. In *Architectural Research Centers Consortium (ARCC), ARCC 1998 Spring Research Conference*, Raleigh, NC, April (pp. 14-18).
- Kwok, A., Grondzik, W., & Haglund, B. 2005. Agents of Change Project: Making Sense of Success. *Proceedings of 30th National Passive Solar Conference—Solar 2005*, Orlando, FL, August 7-12, 2005 (pp. 2431-2436).
- Little, R. 1999. Educating the Infrastructure Professional: A New Curriculum for a New Discipline. *Public Works Management & Policy* 4: 93-99.
- Magent, C., et al. 2009. A design process evaluation method for sustainable buildings. *Architectural Engineering and Design Management*, 5(1): 62–74.
- Newsham, G.R., Mancini, S., and Birt, B.J. 2009. Do LEED-certified buildings save energy? Yes, but...., *Energy and Buildings*, 41 (8): 897-905.
- Nguyen, T. A., & Aiello, M. 2013. Energy intelligent buildings based on user activity: A survey. *Energy and buildings*, 56, 244-257.
- Ramesh, T., Prakash, R., Shukla, K.K., 2010. Life cycle energy analysis of buildings: An overview, *Energy and Buildings*, 42(10): 1592-1600.
- Scofield, J.H. 2009. Do LEED-certified buildings save energy? Not really... *Energy and Buildings* 41(12): 1386-1390.
- Simpson, T. W., Hunter, S. T., Bryant-Arnold, C., Parkinson, M., Barton, R. R., Celento, D. and Messner, J., 2009. Interdisciplinary Graduate Design Programs: Results and Recommendations from a NSF Workshop. In *2009 ASME Design Engineering Technical Conferences*, San Diego, CA, ASME, DETC2009/DEC-86699.
- Turner, C., & Frankel, M. 2008. Energy Performance of LEED for New Construction Buildings. Vancouver, WA: New Buildings Institute. Available at: <http://newbuildings.org/energy-performance-lead-new-construction-buildings> [Accessed 06 August 2013]
- Ulrich, R. S. 2006. Essay: Evidence-based health-care architecture. *The Lancet*, 368, S38-S39.
- US Congress. 2007. Energy Independence and Security Act of 2007. Available at: <http://www.gpo.gov/fdsys/pkg/BILLS-110hr6enr/pdf/BILLS-110hr6enr.pdf> [Accessed 06 August 2013]
- US Department of Energy (DOE). 2011. Buildings Energy Data Book, US Department of Energy. Available at: <http://www.btscoredatabook.net/> [Accessed 06 August 2013].
- US Environmental Protection Agency. 2013. Green Building: Basic Information. Available at: <http://www.epa.gov/greenbuilding/pubs/about.htm> [Accessed 06 August 2013]

Scaffolding: Discourse, disruption, and progress in architecture as a cultural production

Leonard R. Bachman¹

¹University of Houston, Houston, TX

ABSTRACT: This paper examines how discourse promotes progress in architecture as a discipline. More specifically, a framework of meta-discourse is proposed for such progress through “scaffolding” among the four realms of architectural investigation: design, research, forensics, and education. Scaffolding here refers to progress made by the interaction of professional, academic, occupational, and disciplinary actors. Historical-interpretive and qualitative methods provide supporting evidence for how such disciplinary realms and actors within them overlap, interact, provoke, and scaffold the entire discipline

KEYWORDS: Discipline, Framework, Theory, Practice, History

“Every profession bears the responsibility to understand the circumstances that enable its existence.”
(Gutman 1998)

INTRODUCTION

Architecture occupies the same four operating domains as other disciplinary pursuits: Professional ethics, Occupational service, Academic credence, and Disciplinary research nourishment (POAD). Unlike other professions however, these domain boundaries tend to divide architecture more than organize it. The division is extensive enough that some architects still deny that architecture even has a disciplinary basis. It is indisputable though that all four of the disciplinary categories are necessary for the operational coexistence of architecture and contemporary society. Functionally, in turn for a monopoly on their, architects agree (1) to be responsible for a large and difficult body of knowledge, (2) to use that knowledge in service to society, and (3) to advance that knowledge forward (e.g., Snyder 1984, Cuff 1992, Gutman 1996, Duffy 1998, Kostof (ed.) 2000, and Stevens, 2002). Beyond that compact, architects expect to enjoy the elite status of professionals and thus have claim to independent choice of work methods, membership in a moral community, reputations as trusted and altruistically motivated knowledge experts, collegial work relations, supportive cohorts, and a large measure of self-regulation. Most of these advantages are common to all professions, but in architecture there is a largely unique additional one at the heart of the motivations: claim to personal authorship of widely acclaimed work.

1.0 THE PROBLEM

Using the construct of scaffolding, and borrowing from social science literature on professionalism; this paper examines how domain interaction might be postured to advance the profession. Scaffolding is a principle in developmental psychology explaining the difference between what can be done by a person alone versus what that same person can do when propped up by supporting resources that are gradually removed (Vygotsky, 1930-1934/1978; Bruner 1960). This paper adopts the scaffolding principle to frame the main structural discourses among the four disciplinary domains as leverage points. An explanatory argument is developed based on discursive interaction among those four realms (Table 1) of architectural investigation and are distinct from the POAD operating domains: Design, Research, Forensics, and Education (DRFE, aka FRED), (Bachman 2013). The goal is to provide a framework clarifying investigative modalities (FRED)

Table 1: Four investigations in architectural inquiry. Source: (Bachman 2013)

Architectural Investigations	DEFINING OPERATIONS
DESIGN	Specific solutions to specific situations
RESEARCH	General understandings addressing generalizable problems
FORENSICS	General understandings applied to specific situations
EDUCATION	General understandings generally dispersed

in architecture and the discursive roles of agents (POAD) that engage in those investigations.

1.1. Scope, context, and method

This paper is similar in scope to social science literature where matters of professionalism are treated as a broad topic. Methodologically, an historical interpretation of postindustrial forces on the discipline of architecture is set against the prevailing paradox of the profession; namely the conflict between its ideals and its actual practices. The comparatively low success of architecture relative to other disciplines and the risk of professional advantage are discussed as impetus toward an introspective meta-discourse.

1.2. Premise

The vital conversations among academia, practice and professional organizations in architecture remain, as a set, relatively unstudied. Against their shared background of disciplinary knowledge, theories, and practices, these discourses provide cybernetic feedback loops that steer the course of architecture as a profession. Such interactions are all negotiated separately as a matter of routine interaction and overlapping roles, but external and internal evidence of disruption suggests these conversations should be considered as a holistic system of forces whose balance deserves an introspective meta-discourse. External evidence for the necessity of this second order, bird's-eye view of architecture is given by the comparative lack of success relative to that of engineering, law, and medicine. Internal evidence is offered by social science literature which identifies architecture as a paradox of professionalism in its tension between ideals and practice.

Beyond mere coherence of the discipline, the internal and external ebb and flow of these disruptions inhibit the function of architects in service to society and risk the continual erosion of its disciplinary boundaries. Furthermore, social and technical contexts are evolving into new and significant demands in the postindustrial context of information society... demands that the chasm between the ideal aspects of design authorship and the practical aspects of in-place performance leave void. How are these vital discourses in architecture constructed so as to advance the progress of its disciplinary realms and enhance its service to society? Further, how can these discourses be advanced and monitored so as to intentionally further architectural progress? To develop and problematize such concerns for discourse, this paper explores how meta-discourse might frame such efforts.

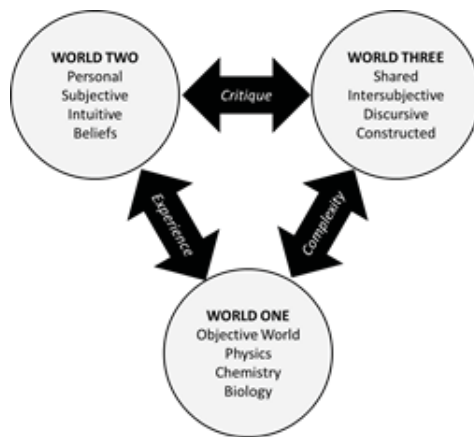

Figure 1: The author's interpretation of popper's three worlds ontology.

A foundational perspective is offered by the postpositive philosopher Karl Popper (1978) in his Three Worlds of Knowledge ontology (Fig. 1). For Popper, the transformation of World 2 personal positions into World 3 shared constructs such as architecture is clearly a function of discourse, debate, and critique. In this view it is evident and commonly accepted that a work is not good because the author believes or asserts it to be, but rather because it has been vetted by public discourse, skeptical comparison, and knowledgeable critique. In other words, there is a transformational difference between subjective knowledge and objective knowledge; and that transformation is only achieved through discourse.

Escape from World 2 subjective knowledge is thus only possible through intersubjective agreement that is negotiated through high level conversation and mapped onto the objective knowledge of World 3. Without

such discourse, our high order structures such as architecture simply do not exist; i.e., without a literature of architecture, there might be great buildings, but there would be no corpus of a thing called architecture.

At another level of granularity, this transformation of World 2 subjectivity into World 3 intersubjective discourse is what constitutes the basic mission of education, occupation, and professionalism. In Popper's own words (ibid, pg. 143):ⁱ

By world 3 I mean the world of the products of the human mind, such as languages; tales and stories and religious myths; scientific conjectures or theories, and mathematical constructions; songs and symphonies; paintings and sculptures. But also aeroplanes and airports and other feats of engineering.

Popper ultimately links World 3 "constructions of the human mind" to the definition of "culture" (ibid, pg. 167) and from cultural evolution to World 3 evolution. This in turn supports the formulation of architecture as a field of cultural production, and thus as a profession. These definitions should be considered in terms of social science investigations into professions, fields, and professionalism; especially as related to the seminal work of Pierre Bourdieu (eg. Bourdieu 1993).ⁱⁱⁱ It is relevant to note at this point that Popper's "field of cultural production" is identical in principle to Bourdieu's use of the same phrase (Sahin-Dikman 2013; 22-24), thus equating shared World 3 constructions achieved through discourse with a profession such as architecture. That point is a fundamental premise of this paper.

1.2. The risks

The past 50 years have dramatically pressed transformations in FRED disciplinary realms and POAD domain actors, especially in light of postindustrial shifts to knowledge-based production, cybernetic decision processes, ecological sustainability, and service economies. An interpretive timeline of these evolutions demonstrates the self-regenerating and constant scaffolding progress of the realms... and hopefully coaxes the actors into new perspectives about their interactions (Table 2).^{iv}

The activity of design has evolved from being synonymous with craft and art in preindustrial times, to that of a professional specialty in the industrial era, and now to a knowledge-based discipline. Architecture was swept along with this evolution as it transformed first into a licensed profession with an accredited university degree, and now evolves into the postindustrial era facing a new societal context, accelerating technical demands, increased regulation, and a rapidly changing marketplace.

As Table 2 indicates, the challenges encountered by the profession of architecture in the postindustrial era are largely the result of transformations in knowledge. Reading any line of the table across from the Eotechnic to the Neotechnic shows how the sufficiency of intuition and personal subjective knowledge is

Table 2: Three eras of designⁱⁱ. Source: (Bachman 2012)

	PRE INDUSTRIAL Before about 1700 The Eotechnic	INDUSTRIAL 1700 to the present The Paleotechnic	POST INDUSTRIAL The evolving present The Neotechnic
Design	Craft and design synonymous	Design as a profession	Design as a discipline
Materials	Raw materials	Mass standardization	Mass customization
Knowledge	Static	Incremental shifts	Continuous change
Cosmology	Mythical explanations	Anthropocentric	Biocentric
Order	Holistic	Hierarchical	Holistic
Development	Refine the prototype	Test unique artifact	Simulate possible artifacts
Change	Conformity	Novelty	Evolutionary
Instrument	Nature as the model	Drawings	Virtual simulations
Method	Normative rules	Policies and procedures	Cybernetic knowledge and systems integration
Perspective	Holistic	Components in isolation	Integrated systems
Dynamics	Innocent naivety	Self-referential	Intelligent
Lifecvcle	Degrade	Use and dispose	Reprocess as nutrient
Solutions	Transient	Fragile & fragmentary	Robust
Effort	Communal	Individual	Team
Educate	Trade apprentice	University: liberal study	Explicit and synthetic
Collaboration	Mono-disciplinary guilds	Multidisciplinary	Transdisciplinary
Application	Need	Art for the elite	Sustain societal goals

giving way to confirmability and publically constructed objective knowledge. In place of normative rules there is complexity. In place of personal expertise and multidisciplinary teams there is transdisciplinary effort. In place of hierarchical machines, there are deeply interrelated systems. In place of genius, talent, and intuition; there are teams, skills, and integrated project approaches.

The corresponding perils—and opportunities—of these transformations are already at hand for both the profession of architecture as a whole and for professional architects as individuals. To focus just on the risks as an impetus toward a disciplinary meta-discourse consider these points:

Constant erosion of professional boundaries as more and more of the built environment is served by a larger and larger number of other occupations, with just so much of the pie to divide among more and more hungry participants;

Regulation such as the ASHRAE 90.1 Energy Code which prescribe performance standards;

Verification of the architects work by third party commissioning agents, value engineers and the like;

Validation of the architect's work by post occupancy evaluation;

Loss of public trust as the scrim of privileged architectural knowledge is stripped away in a cybernetic world... and the consequential perception of architecture as a self-interested monopoly that one can do without and;

Erosion of identity via dismissal of the architect's mythical individualist and heroic figure.

To that point-wise list (which should probably be much longer), professional autonomy in many professions, especially that of the sole practitioner or small firm, is also being eroded by the growth of corporate management of professions. According to statistics from the American Institute of Architects (AIA 2012, 2014, Vinnitskaya 2013) there are some 105,000 registered architects in the United States working in about 17,500 firms, but 17% of registered architects are not working in architecture. By the reported distribution of work employment for various firm sizes then, it seems that about 30% of all those architects work for the 175 firms employing more than 100 architects. Another 20% or so work in firms of 50 to 99 total employees. The same data state that the 1% of firms over 100 employees accounts for more than 33% of all billings while sole practitioners account for another 2%. While working for a large firm is by no means a slight to any architect, the trend represents what Garry Stevens clearly identifies as the prevalence of a very few "major" architects and the proliferation of many "minor" architects (Stevens 2002, 142). The point here is not to stratify classes of architects or infer that large firm architects are less likely to succeed, but rather to point out that this trend is contrary to the image the profession projects as the ideal career where every individual should aspire to name brand authorship of significant buildings.

1.3. Architecture in the literature of professionalism

To summarize what the apparatus of social science literature makes of the architect's situation, consider this excerpt:

An examination of architecture as a case study suggests that the architectural profession can be thought of as a field driven by the ideals of design originality and a field ridden with permanent conflicts between its autonomous ideals and external demands, between creative and symbolic capital on the one hand and technical-managerial capital on the other, and between the competing narratives of its realities. The architectural field is divided and its dominant representation is contested, but architects are also united by their shared experiences and belief in architectural ideals. (Sahin-Dikman 2013, 2)

So while this paper is too short for an extensive literature review of architecture as a profession, some comments shall suffice to indicate the architect's general paradox. A thorough and up-to-date review of that literature is available in Melahat Sahin-Dikman's dissertation for further depth (*ibid*).

Both external studies from social science (e.g., Kaye 1960, Gutman 1998, Sahin-Dikman 2013) and internal studies from writers embedded in architecture (e.g., Stevens 1998, Cuff 1991, Duffy 1998) note the struggle between "autonomous ideals and external demands" as the dominant theme and disruptive force of architecture as a profession. For the purposes of this paper, that disruption is manifested in the disconnect between what architecture says about itself, and what architects actually do as an operational reality—in other words, between the discourse and the job. With so much evidence at hand and so little in the way of counter-claims or optional perspectives, this paper suggests that a more persistent and productive meta-discourse negotiated by all the actors is necessary for the next order evolutions of architecture as a profession.

It must also be emphasized that discourse and meta-discourse are not framed here as the need for negative criticism and constant calls for radical change. The tension between design ideals and occupational practicality can itself even be framed positively as an essential animating force—something social science is

likely to overlook—but the disconnect suggests increased vulnerability to professional erosion and weakening of occupational boundaries if left to the default existing conditions.

2.0 REALMS AND ACTORS

Table 3: The four investigations in architecture and their correlation matrix

Scaffolding Dynamics		ESSENTIAL TRANSFORMATIONS		CONNECTIVE CONFIGURATIONS	
		DESIGN	RESEARCH	FORENSICS	EDUCATION
ESSENTIAL TRANSFORMATIONS	DESIGN	Bridging from real to ideal, abduction, analytical method to synthetic philosophy	Precedents, typology, systems...	Programming, project criteria, problem space definition...	History, theory, critique, and discourse toward abductive propositions
	RESEARCH	Theory, method, history, criticism...	From philosophical analysis to methodical synthesis... New generalizable knowledge applicable to a general set of situations;	Applied research, technology, systems integration, postoccupancy studies	Information literacy, methodology, propositions, operationalizing, measurement
CONNECTIVE CONFIGURATIONS	FORENSICS	Commissioning, postoccupancy, performance	Clinical analysis	Application of general clinical knowledge to one specific case, one case based on many cases... Problem space definition	Connective configurations of existing knowledge
	EDUCATION	Case based propositions and synthesis	The scholarship of teaching and learning (SOTL)	Case based analysis	Lifetime of teaching and learning toward mastery of theory and principles

Table 4: Disruptive discourse correlation matrix

POAD Interaction Sets	PROFESSION	OCCUPATION	ACADEMY	DISCIPLINE
PROFESSION	Community of ethical governance and resources	Ethics, regulation, and society	Standards and accreditation	Large and difficult knowledge base
OCCUPATION	Discourse of value	Contract of service to society toward gratification and ennoblement	Lifetime of learning, recruitment, new skills, critique	Application of knowledge in service to society
ACADEMY	Discourse of relevance	Discourse of experience	Basic knowledge, research, and indoctrination	Knowledge and theory development
DISCIPLINE	Discourse of principles	Discourse of competency	Discourse of knowledge	Propagation of theories and principles

Table 5: Traits of the FRED domains. Source: (Bachman, 2013)

Realms & Dimensions	DESIGN	RESEARCH	FORENSICS	EDUCATION
SCOPE	Physical	Positive, post-positive, and emancipatory	Strategic, clinical	Lifetime of teaching and learning
METHODS	Bridging the real and the ideal	Expanding wisdom and eroding existing paradigms	Information literacy	The scholarship of teaching and learning (SOTL)
SETTINGS	The built environment	Scholarly literature	Project specific	Principles, theories, practices, ethics
TACTICS	Precedent based, contextual, intentional, and opportunistic	Naturalistic, qualitative, and quantitative	Cybernetics, complex systems	History/Theory/ Criticism, studio, technology, and core topics
TRUTH VALUE	Essential transformations	Essential transformations	Connective configurations	Connective configurations
NOVELTY	Transformative, appropriate, and intentional	Contingent truth	Discovery and invention	Autopoietic reproduction of the profession
GENERALIZABLE	Critique and discourse	Reliability, validity, confirmability, transferability, triangulation	Embodied human intelligence	Advancement of best practices

A 4x4 FRED matrix expounds six well-known scaffolding dynamics (using the tilde symbol for complementary pairs after Kelso 2006) as research~design, forensics~research, education~design, and so forth (Table 3). In application, these interactions also express practical relationships among the four principle (POAD) domain actors in architecture: Professional community, Occupational practitioners, Academic education, and shared Disciplinary foundations. Each pair also frames a discourse that moves the discipline of architecture forward (Table 4). For the theme of “research in practice” as just one example of a contemporary ambiguity (Groat & Wang, 2013), the agents Academy and Occupation might be selectively examined.

As in other disciplines, in architecture the POAD actors often play dual or even multiple roles: educators are frequently practitioners who directly participate in all four FRED realms. Office based practitioners increasingly engage in some form of research, be it as a service, as internal investment in learning, or both.

Those who serve in professional organizations towards ethical governance are also taken from the pools of academics and practitioners. And again, like other disciplines, there is a shared domain towards which all actors contribute to and draw from: the disciplinary base of theories and principles upon which their authority is grounded. Ultimately however, the actors must change hats as they cross from one FRED realm to the next... the traits of each are realm specific (Table 5).

2.0 THE DISCOURSES

As an instigation only, the following sections outline the main features of discourse among the academic, occupational, and professional organization agents of architecture as well as their shared disciplinary context. This sketch of a structure is probably a necessary premise to any meta-discourse about architecture as a profession, but previous works already cited have previously broached the main categories of discussion and laid out basic relations among the same primary agents.

3.1. Occupation and academia—discourse on experience, research, learning, and critique

As a field of professional study, many academicians are also practicing architects, or have currency in the practice of architecture. This particular discourse may however be the most obvious source of paradox between how the architect’s autonomy and power are represented in education versus how their restraints and responsibilities happen in practice. All that aside, it seems ideal that the academy would provide practice with not just new candidates to the profession, but also with balanced critique, new methods and techniques, counterproposals set against major practice projects, postoccupancy evaluations, and validated research. Practice in return not only reciprocates through accreditation standards and reviews of academic

institutions, but also through direct feedback on academic learning outcomes produced and the effective preparedness of graduates to enter the profession. The last point seems to ask how much “unlearning” happens in internship.

3.2. Occupation and profession—discourse on value, ethics, and service

Relations between the professional organizations and practitioners are well-structured and the role of those organizations in representing practitioner’s interests to public society and governmental institutions is relatively straightforward. Similarly, the organization’s role in framing ethical conduct in practice is acknowledged and respected. Part of that conversation is of course the definition and maintenance of the profession’s status, licensure, competitive fairness, and architecture’s defensible boundaries of the built environment marketplace against intrusion from outside. In supporting and funding the professional organizations, architects also form a community of practice and mutual support mechanism.

3.3. Academia and profession—discourse on relevance and standards

In tandem with governmental regulatory agencies, professional organizations also provide standards for academic program curricula and accreditation, with some movement toward learning assessment requirements and ongoing program refinement. The interactions involved in this validation process inevitably leads to push-pull negotiations as to what constitutes reasonable expectations, what external trends should be accommodated, and what the common denominator standards should be.

3.4. Scaffolding: shared discourse on the discipline—theory, knowledge, principles, and competency

To be a profession, architecture must claim a large and difficult body of knowledge, understandings, and wisdom by which it will benefit society. Evidence shows that this disciplinary knowledge base is continually engaged in the design, research, forensic, and education aspects of its activities and that professional organizations, practicing architects, and working academicians transform this work from subjective knowledge to objective knowledge through continual negotiation and agreement. Ideally this engagement alone would maintain and elevate the enterprise of architecture as a field of cultural production; but disruptions of postindustrial evolution and the complexity associated with the scope of architecture demand that a managing meta-discourse arise to scaffold progress.

CONCLUSION

Neither an art, nor a science; not an ideal, nor a normative practice... architecture is the bridge which connects such polarities by infusing innovative technology with sublime meaning and manifesting ideal visions with concrete realizations. Confronted with the complexity of this holistic challenge however, architects may too often default back to the individualist self-expression model of the heroic designer.^Y From that limited individual position of subjective understandings, architects can generally avoid the larger meta-context of their profession and engage it only when it provides leverage for their own personal viewpoints, or when it threatens to infringe on their standing as professional elites. In counterpoint, in the transition from preindustrial art/craft through the industrial age of professionalization; the individualist tact was not entirely unsuccessful or without social merit. In the emerging postindustrial context, something different must evolve.

This is not to say that architects are an irresponsible lot, or that they give no care to their profession as an institution or the role of that institution in society. But the fundamental difference between architecture and professions such as law, medicine, and engineering is that urge to individual subjective knowledge. A pluralistic mindset will be required if both the design ideals and the practical sustenance of the collective profession are to be maintained.

REFERENCES

- Spiro Kostof. 2000. *The Architect: Chapters in the History of the Profession*. Berkeley: University of California Press.
- Abbott, A. D. 1988. *The System of Professions: An Essay on the Division of Expert Labor*. Chicago: University of Chicago Press.
- AIA. 2012 *AIA/NCARB Internship and Career Survey*. Accessed 5 December 2014. <http://www.aia.org/aiaucmp/groups/aia/documents/pdf/aiab098444.pdf> .
- AIA. 2014. AIA Architect, *Practicing Architecture: get on the good foot*. Accessed 1 December 2014. <http://www.aia.org/practicing/AIAB104583> .
- Bachman, L. R. 2012. *Two Spheres: Physical and Strategic Design in Architecture*. London ; New York: Routledge.

- Bachman, L. R. 2013. *Four Gates to Castle Neos: A native framework for architectural inquiry*. Proceedings of the 2013 ARCC Conference on Architectural Research. Charlotte, NC. March 27-30. Accessed 27 October, 2014. <http://www.arcc-journal.org/index.php/repository/article/view/231>
- Bachman, L. R. 2014. *New Professionalism: the post-industrial context*. Building Research & Information. Vol. 41, 6, p 752-760.
- Bachman, L. R. 2010. *The Teaching of Research and the Research on Teaching: two frameworks and their overlay in architectural education*. Proceedings of the 2010 ARCC/EAAE International Conference on Architectural Research. Washington, D.C. June 24-26. Accessed 27 October, 2014. <http://www.aia.org/aiaucmp/groups/aia/documents/pdf/aia087184.pdf> .
- Bourdieu, P. 1993. *The Field of Cultural Production*. Edited by Randal Johnson. 1st edition. New York: Columbia University Press.
- Bruner, J. S. 1960. *The Process of Education; a Searching Discussion of School Education Opening New Paths to Learning and Teaching*. First Edition edition. Harvard University Press.
- Cuff, D. 1992. *Architecture: The Story of Practice*. Cambridge, Mass.: The MIT Press.
- Duffy, F. 1998. *Architectural Knowledge: The Idea of a Profession*. Hutton, Les. London: Spon.
- Groat, L. N., and Wang, D. 2013. *Architectural Research Methods*. 2 edition. Amsterdam ; Boston: Wiley.
- Gutman, R. 1996. *Architectural Practice: A Critical View*. 5th ed. edition. New York, N.Y: Princeton Architectural Press.
- B, Kaye. 1960. *The Development of the Architectural Profession in Britain. A Sociological Study*. First Edition edition. George Allen & Unwin.
- Kelso, J. A. S., and Engstrøm, D. A.. 2008. *The Complementary Nature*. Cambridge, Mass.; London: A Bradford Book.
- Malecha, M. 2005. *The learning organization and evolution of practice academy concepts*, Raleigh, NC: North Carolina State University College of Design
- Popper, K. 1978. *The Tanner Lectures on Human Values: Three Worlds*. University of London. http://tannerlectures.utah.edu/_documents/a-to-z/p/popper80.pdf. Accessed 30 November 2014.
- Sahin-Dikmen, M. 2013. *A Bourdieusian Lens on to Professions: a case study of architecture*.(PhD diss., University of York. Accessed 5 December 2014. <http://etheses.whiterose.ac.uk/5616/> .
- Snyder, J. C. 1984. *Architectural Research*. Environmental Design Series ;; v. 6; Variation: Environmental Design Series (Stroudsburg, Pa.) ;; v. 6. New York: Van Nostrand Reinhold.
- Stevens, G. 2002. *The Favored Circle: The Social Foundations of Architectural Distinction*. The MIT Press.
- Vinnitskaya, I. 2013. *AIA/NCARB Survey Indicates Resurgence in Employment Rates for Architects* 15 Apr 2013. ArchDaily. Accessed 05 Dec 2014. <<http://www.archdaily.com/?p=359798>>
- Vygotsky, L. S. 1978. *Mind in society: The development of higher psychological processes* (M. Cole, V. John-Steiner, S. Scribner & E. Souberman., Eds.) (A. R. Luria, M. Lopez-Morillas & M. Cole [with J. V. Wertsch], Trans.) Cambridge, Mass.: Harvard University Press. (Original manuscripts [ca. 1930-1934])

ENDNOTES

ⁱ A similar set of arguments is offered by Aldus Huxley's *Knowledge and Understanding* where declarative (what, where, and when) and procedural (how) questions are distinguished from structural (why) understandings. In architectural literature, Garry Stephens' *The Favored Circle* (2002) is dedicated to the assertion on flawed disciplinary assumptions in architecture. Similarly, Tom Heath's *What, if Anything, is an Architect?* (1991) satirizes the architect at length and points to characteristic fallacies in architectural discourse.

ⁱⁱ Patrick Geddes and Lewis Mumford jointly coined the Eo-, Paleo-, and Neo-Technic terms to frame history into three eras of production. See Geddes (1915) *Cities in Evolution* or Mumford (1934) *Technics and Civilization*.

ⁱⁱⁱ For more discussion on the intersection of Popper and Bourdieu, see Grenfell's *Pierre Bourdieu: Agent Provocateur* (2004, pp 172-173).

The promenade of the street: A spatio-temporal framework for design

Mark Blizard¹, Curtis Fish¹

¹University of Texas at San Antonio, San Antonio, TX

ABSTRACT: This paper begins with an outline of our on-going study of the spatial and temporal structure of streets in Urbino, Italy. As part of an architectural study abroad program, twelve credit hours of coursework—including urban theory, analytical drawing, and a research studio—are brought together to focus on an archaeological study of *place*. From this foundation, the paper presents the method and findings of the urban analysis, and the process that has shaped a deeper and more complex understanding of the *identity of place* and its *genetic code*. The inquiry began with the integration of high definition video cameras and their digital environments for the purpose of examining movement and the spatial passage of the street. The indefinite figure and vague boundaries of the street, as well as its visual and mnemonic extensions, resist any clear grasp of the street as a distinct artifact. What we discovered, along with our student collaborators, was that the digital tools illuminated both elements and structure—describing a *matrix* that is at once an organizing armature of the street and a key to understanding its identity as an urban artifact. The results point to the possibility that this matrix and its specific attributes, when integrated into a design process, provides a means for forming conjectures, developing designs, and evaluating design proposals. The resulting architecture would have the qualities of a *place* and would be integrated respectfully into the surrounding fabric.

The street, and by extension the entire city, is perceived and understood through the experience of sequential movement that occurs over time and through space. Along the street the frame of reference constantly changes. Space and matter seem to deform as they are drawn from the center of the visual frame to its periphery. The complex figure of the street is formed from a web of boundaries and centers, from things appearing to separate or merge together, from distinctions that mark beginnings and endings, from sequences of space that expand, contract or merge, and from repeated patterns of elements. Beyond these, memory plays a vital role in situating experience within a larger fabric of connections and apparent folds. In spite of continual changing experience along the street, it retains its identity, and even unity. To pass through a street is to inhabit a *place* that has distinct character and structure. The organization—its tempo, rhythm, pattern, and spatial sequence—forms an intelligible matrix that is coincident with the visible concrete reality. Our initial analysis sought to map and measure the extent and definition of its envelope. What we found was that the attributes of the matrix formed categories: elemental patterns and repetitions, beginnings and endings, sequences of events and spaces, frames, folds, webs, centers and boundaries. These fundamental attributes offer insight into the nature and identity of place that reaches beyond traditional studies and definitions. This paper proposes that the matrix and digital-video processes can provide a framework for the design process itself—examining these within an undergraduate design studio.

KEYWORDS: Architecture, Street, Place, Urban Analysis, Design Education

INTRODUCTION

As an urban artifact, the street remains elusive. Its boundaries are often indistinct and are perceived in our traverse as elastic—capable of deforming relative to the position of our eyes. We only perceive parts of it at any one time: a particular grouping of elements, a pattern of openings in the wall, or sequence of spaces. Yet, it still maintains its identity as a distinct place. It is our position that the *promenade*—our traverse—shapes this *sense of place* and must necessarily be considered in any discussion of the street either as an artifact or a place. In writing these words, we are reminded of Henri Lefebvre's monumental work, *The Production of Space*, in particular, this statement: "Space commands bodies, prescribing or proscribing gestures, routes and distances to be covered" (Lefebvre, 1991, 143).

The street is a set of elements and spaces that are held together and have been fashioned, in part, by their common use over time. Over time, they come to support, or at least complement, each other. In order to apprehend the street, we take measure of its breadth, length, and height as if it were any other urban artifact—recording and documenting in plan and section. Yet, the street seems to defy our traditional methods of analysis and measurement. We must turn towards other means—new digital video technologies and post-production software. Using the digital technologies, we can slow it down in time and take it apart frame by frame. It is our hypothesis that this focused analysis is applicable to the design process itself.

In the spring semesters of 2013 and 2014, we produced an analytical study of the structure and the identity of the streets within the historic fabric of Urbino, Italy as part of a study abroad program for students of the College of Architecture Construction and Planning at UTSA. Building upon the findings of these studies, we have developed the structure and content of our present architectural design studio in San Antonio (Spring, 2015). Our choice of digital video technology was based on our desire to find a means to explore the effects of movement through the space of the street—in Le Corbusier's terms, the *promenade architecturale*. Before we consider the effect and nature of the *promenade* and its temporal and spatial ramifications, we will consider the street as an artifact.

Premise: The street as an urban artifact

The street as an artifact is difficult to grasp. A building, unlike a street, often resembles an object that can be picked up and turned over. Rotating it or passing it back and forth between our hands, we examine it. Its identity is understood through its figure and is seemingly definite, fixed, and static. In fact, it seems to exist outside of any context. Yet, any architectural artifact has much in common with a work of sculpture that we must consider from many angles as we move around or through it. There is no privileged side or façade to the street even as there is none to the sculpture of Henry Moore or the mobiles of Alexander Calder, for example. We cannot imagine gaining much insight from either plans or sections of these sculptural works. Even as we perceive a building, we assemble its identity as a composite image whose pieces are grasped as belonging to a definite whole. Within the city, we find our selves considering a church: we walk around the piazza on the outside, or through the nave on the interior, perhaps passing from a side aisle to a small chapel. Each analytical drawing measures it, takes it apart, queries it, and reassembles it. The plan and the section present its structure and continuity and allow us to identify it. The street, often devoid of any apparent rational order, resists this sort of analysis. Many streets do not have such a clear unity. Their identity appears to be linked to their temporal extension—grasped only in our traverse—or their place within the larger urban fabric.

The street is not made up of elevations or even sections as the use of orthographic drawings suggest. Indeed, these representations impose what is an incomplete measure. We approach each building in our *promenade* obliquely—there are no elevations. It is in the narrowness of the street and in the clarity of its edges that we find a clue to its identity. In the proximity of each of the walls—to the left and to the right along the *promenade*—we perceive changes in the street's volume, structure, and character. It may also be useful to consider the *promenade* as a succession of implied or literal frames: bringing depth of space and the element of time into our experience. The edges of the street—primarily its walls and overhangs—serve as bounding edges to a frames that captures a portion of something beyond—whether the next event along the *promenade* or a distant prospect.¹

Le Corbusier's *promenade architecturale*

The city is understood as we move through it:

Inside: we enter, we walk around, we look at things while walking around and the forms take on meaning, they expand, they combine with one another. Outside: we approach, we see, we discover. We receive a series of sensory shocks, one after the other, varying in emotion [...] We walk, we turn, we never stop moving or turning towards things. Note the tools we use to perceive architecture... the architectural sensation we experience stems from hundreds of different perceptions. It is the 'promenade', the movements we make that act as the motor for architectural events (Pauly, 2008, 29).

It is while walking from one place to another that we see how both street and city are organized, how their elements are distributed, positioned, and oriented. We work out an understanding of each place that is inseparable from the organization, material conditions, and arrangement of their artifacts and spaces. Along our path, groupings of elements, sequences of spaces, webs of connections, mnemonic folds and analogies are fashioned. The *promenade* carries us through space and time and is inextricable from the street or the city itself.

Since 1936, when the term was introduced by Le Corbusier *promenade architecturale* has remained within the jurisdiction of individual buildings (Pauly, 2008, 29). Our experience of the city and its streets is like a montage. In place, things are brought together sequentially and mnemonically forming meaningful wholes, shaped by our movement. The *promenade*, or traverse of the street, presents the sequential spaces as a continuum—as expanding and contracting space populated by things that are distributed over time—rather than as a “string of pearls”. Between any two events or elements within this set, another can be found. What we discover is that the street is comprised of sets of nested, overlapping architectural events at different scales; however, these cannot be understood outside of the larger context of the city and our experiential framework.

Literary review

While many other designers and theoreticians have investigated the street and its relationship to the urban fabric, few have directly addressed the street as an urban artifact, and even fewer have studied the street as both a spatial and temporal structure. The street has been the subject of study as a framework for social

structure as in Bernard Rudofsky's *Streets for People: A Primer for Americans* (1982). Allen Jacobs's comparative study of *Great Streets* has suggested the possibility of generating taxonomic categories of streets based on their plans and sections. Saverio Muratori's study of urban typomorphology and his notion of the city, as an organism, has led, in part, to Aldo Rossi's study of the city. *Street Design* (2013) by John Massengale and Victor Dover is in part a New Urbanist design primer. While these readings, and others too numerous to mention here, offer insight into many of the questions surrounding the street's structure and identity, they fall short of addressing the street relative to space, time, and experience.

In her book, *Le Corbusier and the Architectural Promenade*, Flora Samuels explores complex spatial narratives as they are related to the observer's path. The organization and the elements that compose Le Corbusier's buildings may be understood through an analysis of the sequential architectural events that take place along the *promenade*. Things are positioned within a spatial and temporal register that is informed by a distinct narrative.² An individual architectural event cannot be isolated but is, rather, bound to the unity of the whole. In much the same way, Piero della Francesca's enigmatic *Flagellation* (1455) depicts two distinct events, separated in time, taking place within the same constructed perspective. To interpret this painting, we must unite the disparate figures and their gestures, the architectural elements and spaces, and the evident temporal displacement within the singular geometric armature.

In *The Architecture of the City*, Aldo Rossi presents his now well-known theory of urban artifacts, collective memory, and typology. In categorizing the street as an artifact, he seems to suggest that urban space has a definite identity and influence on urban morphology (Rossi, 1984). He states that, "When we consider the spatial aspect of primary elements and their role independent of their function, we realize how closely they are identified with their presence in the city. They possess a value 'in themselves,' but also a value dependent on their place within the city" (Rossi, 1984, 87). The proposition that the street is not only an armature for growth, but also a generator of the city's form is important to understand. Yet, this idea that the street is an urban artifact is not significantly developed in Rossi's book.

In considering Giancarlo de Carlo's operational strategy of *reading the territory*, John McKean writes "deciphering the signs inscribed in the territory makes the place, its buildings or its land, comprehensible to the mind and the senses" (McKean, 2004, 49). It is important to distinguish between *place* and its *genetic code*. Place is an amalgamation of factors and conditions, including social, economic, political, and other cultural forces in union with the land and the elements that together compose the constructed environment. There seems to be something fixed or stable within the nature of a place such that it retains its identity even as it changes over time. De Carlo considered this stable element to be found in its *genetic code*—a site-specific "dialogue" between interventions and the environment. De Carlo's consideration of the *genetic code* is similar in many ways to Norberg-Schulz's use of the term *genius loci*, or governing spirit of a place. Norberg-Schulz, writing from a phenomenological position, offered what amounts to a list of qualities of place that served as the core for our study. As an initial armature for our study, we developed an expanded list of the attributes of the genetic code drawing from Norberg-Schulz's work.³

Although his seminal work, *Wisdom Sits in Places*, is a specific study of the interwoven fabric of language and landscape of the Cibecue Apache, it offers deep insight into place-making in general. Place itself is grasped as a constellation of elements that are bound into a single narrative web. To remove one of these elements is to change our sense of the place. Place is encountered as a simultaneity of physical and mnemonic attributes that are structured in space and in time (Basso, 1996).

Cullen focused his landmark book, *The Concise Townscape*, on the "spatial aspect" of the city's primary elements. Essentially, he introduced the notion of *serial vision* through a series of static perspectival frames that were set in reference to the city's primary elements as positioned in plan. The city's streets, open spaces, and piazzas served as an organizational structure: a datum along which views were positioned and framed (Cullen, 2009). Informed by the technology of its time, the photograph's still frame, *serial vision* recognized the presence of movement in space but was not, in itself, spatial (Cullen 2009). In *The Italian Townscape*, Ivor De Wolfe based his observations of the Italian urban fabric on Cullen's Townscape principles—*serial vision* in particular. These provided a schematic for the study of spatial patterns that relate the organization of the city as measured in plan with sequential perspectival frames (De Wolfe, 1963).

The study: instruments, methodology, and context

Our two-year analysis of sixteen selected streets in Urbino initially followed a conventional method. Measured drawings were prepared and we took account of the material palette. The character of the street—its sequential spaces and the effect of the street as a frame—was studied through sketching. The camera (still photography) was first introduced as a means of gathering images: documenting elements, materials, and spatial conditions along the street.

The video camera, like all instruments, is a filter that at once clarifies and distorts the field of study. We found that, to the extent that it screened out the situational "background noise"—that excess of visual information that surrounds us—the camera brought parts of the street into sharper focus. Learning to see through the video camera and its digital environment involved experimentation with its possibilities and

limitations. The eye was extended, tilted, or displaced. Time was slowed down, or sped up. Jigs were employed throughout the filming in order to reposition the eye or stabilize the frame. The camera became, in effect, an extension of vision, and eventually, the tools and processes involved formed a mode of thinking about the street. Throughout the process, the camera silenced the normal common sense process of recognition whereby things are recognized rather than actually seen. The camera's frame transformed the object perceived by differentiating it from its field. This allowed greater awareness and clarity. The framed object, replete with its newly perceived qualities of changing light and shadow, position, juxtapositions, and overlaps stood out. Behind the lens, we became acutely aware of the things before our eyes: separating and differentiating, or else drawing together and merging.

The video capture and manipulation techniques provided a mode of thinking about the street in all of its nuances. The raw footage systematically captured the complete traverse of the street. Each pass of the camera along the traverse of the street was focused on different aspects of the experience: the urban ceiling where the buildings met the sky, the urban floor where earth and wall met, the boundaries and edges, the sequence of spaces, and the visual frames that extended the experience beyond its immediacy. In an editorial process, the raw footage was transformed into a base video. We had to consider how the secondary, often elliptical, sequences would fit into the base video—departing from its structure and then returning to it.

Various operations were used: splicing, various digital effects and the inclusion of an aural soundscape—generated in layers in conjunction with the spatial qualities or elements present in the video. The digital environment enabled a frame-by-frame comparison and the measurement of incremental time that moved both forward and backward. We noted elements and their frequency and location, as well as the periodic patterns and repetitions. Recurring elements or spaces gave the street a rhythm and, at times, brought a series of mnemonic “folds” to the experience. The city ceased to be a fixed object as we discovered the complex weave of spaces and elements within which the time of experience, historical time, and memory merged. It became a language through which the street was approached anew. The digital tools enabled us to reimagine the street in layers. We also noticed that the envelope or extent of the street was never as clear as it seemed at first. In other words, the street's identity was, upon closer examination, somewhat ambiguous. Its figure constantly deformed and its boundaries were multiple, overlapping, and at times contradictory. A single element, for instance, might belong to several distinct overlapping or nested places. Importantly, we uncovered what amounted to a web. The elements along each street formed constellations in accordance with their similarity or position: resemblance, number, sequence, structure, figure, frame, analogy, type, use, and material.

Primary finding: the matrix

As we trace a path in our *promenade*, our perception is on several levels simultaneously. The street seems present as a structure and as events and frames that are sequential or overlapping—held between a beginning and an ending. Its geometric form cannot be separated from the material and space of which it is composed. This dense tissue is grasped sequentially. If we consider the street as having a language—a vocabulary of elements and a grammar of rules or patterns—the matrix is analogous to its syntax. This spatial and temporal geometry makes sense of things gathered or connected by the street. The matrix is not merely an organization or the principle of that organization. It provides a structure for the constituent parts of what De Carlo calls the *genetic code*. We propose that the individual qualities of the street's matrix should be examined concurrently with its physical attributes. The temporal framework needs to be taken into account, as things are not independent from a *before and after*, *here and there*, or *this one and that one*. In the words of Anne Friedberg, “Architecture is experienced in a complex matrix of space” (Friedberg, 2006, 150). Movement is movement *into*, *out of*, *beyond*, *alongside*, *under*, *across*, *up*, *down*, and *through*. The street's matrix is not a coincidental or contingent property of the urban artifact but is inextricable from the street itself. The street, and perhaps all places, is a *formwork*. Even as a single building cannot be perceived in its entirety outside of its situation and context, the street cannot be grasped outside of its connections and relationships to the larger environment of both city and land. The street is slowly absorbed sequentially as a series of more or less distinct moments or events in time—each with its typical configuration: intersections, hinges, bends, turns, pauses, openings, expansions, restrictions, releases—that are woven together, forming a distinct whole. In this way, the street is a time line—a temporal datum that organizes our encounters with things—forming a mnemonic that makes connections to things unseen.

In reference to Le Corbusier's *promenade architectural*, Samuel states that, “The body of course plays a central role in all of this. It would act as the vital intermediary in any transaction of knowledge between building and brain that would take place on the promenade” (Samuel, 2010, 27). The body perceives the street by its resistance—slope, narrowness, the quality of light, the height of walls, adjacency, pattern, sequence, texture, etc. The difficult part is to find some way to measure these perceptions and to understand how their relationship forms the street's particular identity and unity. This is the purpose and question that directs our current design studio. The matrix provides the structure for their interaction and shapes our perception of the street as a distinct *place*, concurrently placing it within the larger fabric of the

city. Characteristics of the matrix can be grouped into material, spatial, and temporal categories that inform and overlap each other:

<i>physical</i>	Tone, Boundaries + Centers, Thresholds, Earth + Sky, Webs
<i>spatial</i>	Rhythm, Spatial types, Frames + Visual Axes, Volume
<i>temporal</i>	Linear, Elastic Perspective, Spatial Sequences, Non-linear (Events + Folds) and Cyclic

Physical characteristics

Tone, or “color”, can be defined as the prevailing effect of the palette of materials, elements, and spaces—their degree, scale, positions, orientation, construction, patterns, and repetitions. Taken together as a totality, these produce a particular *intonation*—an existing state of characteristics, tensions, and resolutions of elements along the street. Tone is determined to a large extent by the material qualities and measure of boundaries and elements, and the changing the quality of light.

Along our *promenade*, as Le Corbusier reminds us, we pass from one event to another—constantly moving between *boundaries and centers*. If we consider an artifact as a sculptural work, we can understand the relative importance of its figure in shaping both our perception and its identity. Streets, as with other urban artifacts, have boundaries—material, spatial, and temporal. They tend to be porous and have distinct identifying characteristics: elements, openings, protrusions, fractures, configuration, location, dimension, proportion, orientation, and material-visceral properties. These architectural events serve as centers. Things take place and certain events “claim our attention” as we draw nearer.

Thresholds occur at that moment where things begin their presence. Necessarily, thresholds are components of boundaries: edges—places of beginnings and endings, insides and outsides. They mark one end of the street and the other. Like bookends, they hold and inform the identity of what is between. Thresholds are often defined by the presence of primary elements. They may also compose a particular view of the city or the landscape beyond. Upon close examination, their exact position and dimension is often vague or blurred. There is no single line of demarcation between *in* and *out*. Likewise, each threshold has a temporal dimension.

The earth and the sky are ever-present—defining the volume of the street. By earth, we mean the connection to land. For De Carlo, this response forms part of the logic between natural forms and cultural construction that is a primary aspect of the genetic code of place (McKean, 2004, x). The street is formed in concert with the resistance of the topography and the composition of the region’s geology. Each street extends upward to the sky. The sky, framed by walls and overhangs, is present as a clear figure that changes along the *promenade*.

Each street gathers, contains, and organizes a *web of things*—making a whole out of what would otherwise be disparate parts, forming figures and groupings. It is a vessel of sorts that provides structure for this network. As a spatial register, the street keeps account of its contents and shapes, our perception of them.

Spatial characteristics

There are two rhythms at play: that of our body as it traverses space and that of the street. The space of the street is both a field of action and the basis for that action (Lefebvre, 1991). Mediating between these orbits is the geometric matrix of the street. Our body, in engaging this active field, is located, oriented, and measured by the street. In turn, our movement becomes a datum by which we survey the street’s passage as it moves and deforms around us. “Architecture marks the passage of geometry from the architectural plane to that of the senses” (Samuel, 2010, 29). The pace of our movement is a counterpoint to that of the city.

We developed a limited family of *spatial types*, each of which was derived from studies in plan and section. Each type formed a category of spatial conditions that were distinguished from one another according to their configuration: “T” intersections, “Y” intersections, hinges, bends, pauses, openings, expansions, restrictions, and releases. Each street’s identity could be plotted out in their sequence of spatial types—corresponding to changes in plan and section. These sequences became a distinguishing mark of individual streets and indicated similarities and differences.

Each street is a series of *framed views and visual axes*. Each frame has a more or less identifiable figure that distinguishes it from the one before and the one that follows. A frame together and holds things—even if only momentarily as we pass. It collapses space and sets both near and far together. The distant vista defines a visual axis that extends the envelope of the street—expanding to encompass the distant view.

Space is contained as a *volume* by the street. Related directly to both plan and section, volumetric space describes the interior space of the street—its three-dimensional extension between one side and the other, between one end and the other, and between earth and sky. To traverse the street is to be within the street’s volume.

Temporal characteristics

The identity of the street is known only over time as seemingly disparate fragments are sutured together to form a meaningful whole. Events take place in time. But linear, or progressive time does not adequately measure our passage with its zigzag procession, its elliptical deviations, its mnemonic folds, its experiential variations, and its visual frames—each a reminder of some thing, place, or event that is now distant. There seem to be three types of time that are at play in the street: linear, non-linear, and cyclic.

Linear

Our footsteps move in *linear time*. In the present, we pass through a sequence of places: a datum from which *before* and *after* are perceived and measured. The rhythm of the street is also demarked by the patterns and repetitions and occurrence of singular or multiple architectural events.

In our *promenade*, *perspective is elastic*. Le Corbusier was intrigued by the experience of the Athenian Acropolis: “The whole thing, being out of square, provides richly varied vistas of a subtle kind; the different masses of the buildings, being asymmetrically arranged, create an intense rhythm. The whole composition is massive, elastic, living, terribly sharp and keen and dominating” (Samuel, 2010, 43). The term *elastic* describes the effect of spatially distributed elements relative to our moving eye. As we move through space, things change their countenance relative to each other.

The spatial volume of the street, as a whole, is perceived in joined *spatial sequences* along the *promenade*. The whole of the street is grasped as a dynamic and changing structure consisting of definitive sequences marked out in space and time by architectural variations. Between, there appears a break or a shift in the spatial qualities: a bend, turn, intersection, widening, restriction, or extension—these are perceived experientially.

Non-linear

Repetitions of elements spaces, or references between places suggest a greater network of connections and folds between things. Events in time are joined. Each, by itself, may be indefinite, incomplete, or only a fragment of some larger, unseen whole or structure. At these moments, time appears to defy the linear measurement of its passage and, like space, seems to expand or contract, or fold upon itself.

An *event* is shaped by the combined effect of elements in space—forming distinct and recognizable patterns that together separate from the background and hold their own identity relative to things that happen. The street is a body of linked architectural events. Each has distinct physical and spatial centers and boundaries and temporal extent or duration. Events can be plotted like a choreographic or musical score.⁴

A *fold* is a collapse in the initial perception of distance and regularity in time. The past and the future are absorbed by the present. Memory is the vehicle for joining and connecting seemingly disparate things. It is as if things were nested, superimposed, or coincident, or existing at different scales simultaneously.

Cyclic time consists of daily, seasonal, or annual repetitions and patterns of events. It is the time of festivals, myths, and rituals, and serves as clock for daily events. Sunlight and seasons cycle slowly. Although we perceived cyclic time in our analysis, it remained distant, vague, and incalculable. We set it aside for the purpose of this project is to focus on the measurable.

Synthesis of the study: our hypothesis

Place has long been a difficult concept to pin down.⁵ Building on our analytical studies in Urbino, we believe that the physical, spatial, and temporal characteristics of the matrix can inform the generation and development of conjectures, the formation of provisional answers, and the testing the resulting solutions. This semester, we are teaching an architectural design studio in San Antonio, Texas whose purpose is to explore the potential of such a design process. San Antonio is obviously a different cultural context from Urbino. Their perception and use of urban space cannot be equated. Our aim is not to replicate the culturally specific attributes of the urban fabric or to consider the image or structure of Urbino’s streets as a source of architectural and spatial forms that could be incorporated into a new setting. We are interested in figuring out a process and methodology that utilizes the spatial and temporal structure of the street (its matrix) and the use of digital video technologies as a design tools. The site we have chosen is in an underdeveloped industrial area near the downtown.

The studio *is* our hypothesis. Rather than considering place-making from its current neo-traditionalist perspective where artifacts and organizational patterns are set into a new contexts, we are proposing that the existing qualities inherent in the *genetic code* of a particular site can be enhanced and developed through the use of the matrix as a means of representing and studying the site, and as a tool in forming and testing the design proposals. The design process becomes a continuation of the analytical process. Analysis reveals the existing matrix that is then systematically adapted as programmatic elements are introduced. Relationships between these elements or “architectural events”, as Le Corbusier would call them, are measured and framed by the *promenade*. The traverse of the street becomes an organizational and design

strategy. The proposed design will coherently link the existing buildings, topography, regional geology, climactic conditions, and cultural fabric of the site. The existing site has qualities of a *place* although these are not readily discerned, often contradictory, or ignored altogether in the progressive development of the site over time. We believe that the qualities and identity of *place* can be enhanced by the insertion of new programmatic elements that are woven into the existing fabric.

The program—generated in collaboration with the students—is a device akin to a choreographer’s score—relating events to place and time. Throughout the design process, each of the characteristics of the matrix will be considered both separately and in combination. Separately, they form distinct architectural events or sequences of events. Unified, they form the *promenade* and through the *promenade*, convey the qualities of *place*. The structure of the existing site, isomorphic with its narrative, will initially organize the new elements. In turn, these new architectural forms will reinforce, deepen, and extend the qualities of place. The new proposals are not placed *on* the site, but woven *into* it. In this sense, we experience not as objects, but as integral parts of a larger fabric. In much the same way, the streets in Urbino were perceived as identifiable wholes even though they were never seen in their entirety.

Design will be conducted in part by using a series of “overlays” grafted over an initial video of the “street”. These will involve sketches, and the use of both traditional drafting tools and digital programs. The digital frame of both camera and computer screen provides the means and the methodology for forming conjectures and testing proposals. In addition to orthographic studies, digital and actual models as well as drawing on successive perspectival printed images will be utilized. Within the expanding matrix, architectural propositions will form webs, folds, sequential spaces, etc. addressing those characteristics that are in need of enhancement in order to strengthen and deepen the sense of place. The final solutions will be carried back into the digital video framework. This will enable a side-by-side comparison with the initial videos the students had done in their analysis of the existing conditions. In one sense, architects perceive and measure the temporal experience of architecture once the work is built.

CONCLUSION

We will remain unsure of the results of the proposed design studio until the semester has concluded. The purpose is to step closer to a place-based architecture that is not an imposition of values, architectural conditions, or stylistic attributes, but that is grounded by the existing *genetic code* and informed by spatio-temporal nature of experience. We seek an architecture that defines, reveals, frames, and enhances, the qualities of *place*. The *promenade* provides a useful platform from which to describe the attributes, identity, and structure of not only the street as an urban “room” but also *place* itself. If this is the case, we reasoned, perhaps the same tools used to analyze the street could be used in the design process.

While our principal study was focused on the street, we propose that an increased awareness of the interwoven existing aspects of *place*, the *promenade* as a means of organizing the design, and the use of digital tools—providing a method of study—will result in designs that are not only appropriate for the places in which they are pursued, but may enhance the latent potentiality and character of *place*. An increased awareness of the temporal structure of the *promenade*—investigated with the aid of digital video will fundamentally change the design process. We caution against beginning the design process with any pre-conceived image, checklist of specific desirable architectural conditions, or stylistic agenda, and applying it to the particular site. *Place* exists in the complex weave of natural forces and conditions that are in dialog with the cultural interventions. *Place* is latent—our task as architects and designers is to draw it to the surface and make it a vital part of the present experience.

REFERENCES

- Basso, Keith. (1996). *Wisdom Sits in Places*. Albuquerque, New Mexico: University of New Mexico Press.
- Casey, Edward S. (1993). *Getting Back into Place: Towards a Renewed Understanding of the Place-World*. Indianapolis, Indiana: University of Indiana Press.
- Cullen, Gordon. (2010). *The Concise Townscape*. New York: Architectural Press.
- De Wolfe, Ivor. (1963). *The Italian Townscape*. London: The Architectural Press.
- Friedberg, Anne. (2006). *The Digital Window: From Alberti to Microsoft*. Cambridge, MA: MIT Press.
- Halprin, Lawrence. (1969). *The RSVP Cycles: Creative Processes in the Human Environment*. New York: George Braziller, Inc.
- Lefebvre, Henri. (1991). *The Production of Space*. Malden Massachusetts: Blackwell Publishing.
- Lejeune, Jean-François. “Schinkel’s Entwürfe zu städtischen Wohngebäuden: *Living All’Antica in the New Bourgeoise City*.” *The Classicist* No. 9, (2011).
- McKean, John. (2004). *Giancarlo de Carlo: Layered Spaces*. London: Edition Axel Menges.
- Norberg-Schulz, Christian. (1985). *The Concept of Dwelling: On the Way to Figurative Architecture*. New York: Rizzoli.
- Norberg-Schulz, Christian. (1984). *Genius Loci: Towards a Phenomenology of Architecture*. New York: Rizzoli.

Pauly, Daniél. (2008). *Le Corbusier: The Chapel at Ronchamp*. Boston, MA: Birkhauser.
Samuel, Flora. (2010). *Le Corbusier and the Architectural Promenade*. Basel, Switzerland: Birkhauser.

¹ An early use of the *promenade architecturale* is found in the late writings of Karl Friedrich Schinkel where, in presenting images of his architectural designs, he attempted to communicate the corporality of architecture by placing it within the context of the street. Essentially, he was proposing a site-specific design response. By setting his work in oblique perspective, as seen from street, Schinkel redefined the urban context and the architectural project in terms of movement along the street and the position of the eye. No longer did the elevation alone convey the architectural design intentions. The building's functionality could not be separated from its place within the urban fabric relative to perception. For further information on Schinkel's understanding of the urban fabric relative to his architectural designs, see: Jean-François Lejeune, "Schinkel's Entwürfe zu städtischen Wohngebäuden: *Living All'Antica in the New Bourgeoise City*." *The Classicist* No. 9, (2011): 9. "Schinkel was perhaps the first architect to set aside the acontextual presentation of both public and private works as seen in the treatises of Andrea Palladio, Claude-Nicolas Ledoux or Jean-Nicolas-Louis Durand, and to systematically present architectural works in their real urban and legal context."

² "The promenade acts as an allegory of life and its possibilities." This allegory is illuminated by Le Corbusier in *Le Poem de L'Angle Droit*. Samuels, 58.

³ In defining the elements of architectural space, Norberg-Schulz initially structures his position around Lynch's *landmark, node, path, region, and edge* (Norberg-Schulz, 1974). In *Genius Loci*, Norberg-Schulz presents a more detailed discussion that is informed to a greater extent by his readings in phenomenology. While acknowledging Lynch, Norberg-Schulz embraces Heidegger's notion of concrete space and dwelling. Here, Norberg-Schulz defines the character of place in a body-centric reading that incorporates such terms as: *figure-ground, boundary-center, centralization, direction, rhythm, proximity, floor, wall, ceiling, and openings*. To this vague and partial list, he adds *space* as a system of relationships between things that are denoted by propositions. An expanded outline of the characteristics of place includes: inside and outside—degree of extension and degree of enclosure; connections to the larger city and to the landscape; center—defining elements and degree of centralization; boundaries—articulation / modulation; enclosure / type of pores / openings—floor, walls, ceiling, their continuity / unity and fractures / disruptions / breaks; elements—form, substance, dimension, number, proportion, location, position, orientation (Norberg-Schulz, 1984).

⁴ For a description and exploration of the score as a means of design development, see: Lawrence Halprin. *The RSVP Cycles: Creative Processes in the Human Environment*. (New York: George Braziller, Inc., 1969).

⁵ For a thorough study of the nature and qualities of place, see: Edward S. Casey. *Getting Back into Place: Towards a Renewed Understanding of the Place-World*. (Indianapolis, Indiana: University of Indiana Press, 1993).

Toolkit for passive house education: Questions, methods, tools

Alison Kwok¹, Walter Grondzik², Katrin Klingenberg³, Mike Kernagis³

¹University of Oregon, Eugene, OR

²Ball State University, Muncie, IN

³Passive House Institute US (PHIUS), Chicago, IL

ABSTRACT: The passive house concept, applied in the U.S., has been shown to reduce space-conditioning use by 65–90% (depending on climate) compared with 2009 IECC code buildings. The passive house method sets target performance criteria that must be addressed during design and met during construction. Passive house education and training for design professionals involve intensive classes on building science principles for envelope construction, thermal comfort, heat gain/loss, ventilation, shading, orientation, and calculations of total primary energy use. The design and construction process offers (and necessitates) collaborative efforts among the designer, builder, owner, and engineer. Understanding the passive house approach offers opportunities for enhanced student involvement, engagement and understanding of ways to reach net-zero energy performance and to address the 2030 Challenge. Infusing passive house principles into the architecture curriculum would provide a means by which this capacity can be made accessible to more designers earlier in their careers.

The objectives of this paper include: a) providing an introduction to the passive house standards relative to other efforts toward high performance design; b) outlining various dissemination models for passive house principles and building performance concepts (drawing upon approaches from several universities in North America—curriculum sequences from seminars, design-build projects, and studios); c) suggesting a toolkit of resources, equipment, tools, and exercises that institutions could use to infuse passivehouse into the curriculum, and d) discussing interactions between architectural education and the professional community and some of the successes and barriers to implementation of such collaborations.

KEYWORDS: Passive House, Knowledge Infusion, High-Performance Building, Education, Research Methods

INTRODUCTION

Passive house, as discussed in this paper, should be distinguished from passive solar design. Passive house is primarily an energy consumption limiting standard that addresses summer and winter heat flows as well as overall primary energy consumption. Passive solar design primarily focuses on the use of solar radiation as a means of providing space heating. Passive house and passive solar are not mutually exclusive concepts—but they are rather dissimilar. This paper will use lower case letters for the term passive house in order to recognize that it is a concept that goes beyond the purview or control of any one organization.

Passive house is a design standard that results in very-low energy buildings (PHIUS, 2014a). Key precepts of the standard include a limit on heating energy demand, a limit on cooling energy demand, a limit on source energy consumption, and a limit on air infiltration. Because passive house requirements focus on demand-side reductions, a passive house is not necessarily a net-zero energy building. It will, however be an exceptionally low energy building—and should be net-zero energy “ready.” The passive house standard is not a new idea, but is experiencing a growing emergence onto the North American design scene and a substantial growth in adoption. It can reasonably be described as a new design paradigm that slots nicely into growing concerns for energy conservation and carbon emission mitigation. Understanding the underlying reasons for the various performance metrics related to carbon emission reduction goals is essential to motivating the next generation to use them to benchmark their designs.

The fundamental question addressed by this paper is: How can a new paradigm be incorporated into architectural curricula? Broadly speaking, this question links into the ongoing tension (or dialog) between practice and academia regarding what should be learned in school and what should be learned in an office (Stevens, 2014). Somewhat more narrowly, the question links—assuming a desire to address the passive house paradigm in academia—to concerns about adding material to already packed architecture programs.

This is not a unique question. Similar parallels exist with the USGBC’s LEED green building rating system (or like programs; USGBC, 2014), with software (such as Autodesk Revit; Autodesk, 2014), or with broad concerns such as addressing the Architecture 2030 Challenge (Architecture 2030, 2014). Curricula, and the courses that comprise them, tend to adapt fairly well to new information at the “awareness” level of scope

and complexity. A new lecture can be developed, some existing content can be squeezed, and additional readings can be assigned. Curricula are less accommodating to new information that requires extensive engagement in order to reach the “ability” level of comprehension. Most architecture programs have no flexibility to simply/easily add a course to address LEED, Revit, carbon-neutral design—or passive house. This is the challenge: How can an emerging topic area requiring reasonable time for ability development be dealt with in a conventional academic program?

There is no clear pattern of previous experiences from which to draw direction. USGBC, in the opinion of the authors, has not engaged the issue of how to embed either LEED awareness or ability into architecture programs. Faculty are left to their own devices as to how this might be accomplished—with no USGBC institutional support. Autodesk, on the other hand, provides free software and tutorials to encourage faculty and students to become familiar (and then proficient) with programs such as Revit. Interestingly, the objectives of USGBC and Autodesk would seem to be the same; namely to encourage use of their respective products. Their modes of diffusion are, however, radically different.

Currently (with a few exceptions) architects gain operational knowledge of passive house design post-graduation through participation in a multi-day training course and completion of an exam. Students are not excluded from this path, but would rarely have either the time or the money to take the CPHC (Certified Passive House Consultant) training (PHIUS, 2014b). This situation tends to delay awareness of passive house opportunities until after graduation and acts to distance active engagement from the venue (architecture school) where many are most amenable to learning.

The passive house community would like to see a greater infusion of passive house design knowledge into North American schools of architecture. Such an infusion would increase awareness of a viable high-performance design option among those arguably most predisposed to be excited by such an option. The passive house standard is, however, a topic where ability (versus awareness) would best spur adoptions. How to make this ability available to architecture students is addressed in more detail below.

1.0 DISSEMINATION MODELS

There are various models for supporting passive house education within architecture curricula. These examples describe the range of possibilities that might lay the foundation for resources, training, and raising of student/faculty awareness.

1.1. A freely-distributed resource package

Make readily available (at no cost to the user) a resource package of slides, videos, and notes that can be adopted (and adapted) by faculty members to use in lectures, projects, and/or a design studio. Such a resource package does not currently exist and external funding is probably required to support both development and dissemination.

1.2. A roving expert show

One or more Certified Passive House Consultant (CPHC) experts might travel to architecture schools and offer one- or two-day workshops, guest lectures (in studio, lecture, and/or seminar classes), or brownbag Q&A sessions with students and faculty. A resource package might be left behind. External funding would be required to support travel and pay for the expert’s time.

1.3. Intensive summer workshops

Experience tells us that there is no shortage of interest on the part of students, but interested faculty need training on passive house concepts and an exchange of ideas about how to conduct a class. A series of intensive weeklong faculty workshops could provide experience with classroom exercises, passive house software, and use of equipment—as well as curricular discussions about implementation issues at various types of institutions. External funding would be required to support presenter and participant travel and accommodations under this option.

1.4. A modestly-priced resource package

Faculty members are encouraged to obtain a purchased resource package for lectures, projects, and/or a class. PHIUS (the Passive House Institute US) has developed a package of materials specifically for higher education venues, with lecture notes and slides that are used in the existing national CPHC training sessions.

2.0 EDUCATIONAL RESOURCES

In addition to the information resources noted in section 1, a number of tools can serve as resources for faculty and students in seminars, lecture classes, design-build settings, or independent study efforts. The experience gained through use of such tools can enhance learning outcomes and provide validation to design decisions. The following list of equipment is not exhaustive, but is intended to suggest how passive house principles, concepts, and design questions can be illustrated through their use.

2.1. Equipment

- Blower door: The current passive house standard requires that air infiltration be limited to 0.6 ACH (air changes per hour) during/after construction. Enabling students to conduct a blower door test on a range of construction types, loose or tight, can be instructive to understanding qualitative and quantitative aspects of air tightness. The learning curve for use of a blower door is moderate; the cost is typically \$2300-\$2800.

- Carbon dioxide meter: Passive house buildings are designed to provide excellent indoor air quality using a heat recovery or energy recovery ventilator to supply fresh outdoor air. Questions about the effectiveness of such a system can be tested with a carbon dioxide meter. Comparisons can be made to ASHRAE Standard 62 *Ventilation for Acceptable Indoor Air Quality* (ASHRAE 62, 2013), which states that indoor air is “acceptable” if it is less than 700 ppm above outdoor air levels (usually around 400 ppm). Carbon dioxide meters cost around \$400-\$500; those with datalogging capabilities around \$700. The learning curve is nominal.

- Infrared (IR) camera: Passive house construction details must avoid thermal bridging. Occurrences of thermal bridging can be observed (or its absence demonstrated) via thermal imaging. IR cameras range greatly in price depending on image resolution, thermal sensitivity, battery life, and operating system compatibility. The learning curve for use of an IR camera can vary from nominal to moderate (depending upon project needs).

- Dataloggers: A key goal of passive house construction is to maintain excellent indoor thermal comfort conditions. Indoor air temperature, relative humidity, and surface temperatures can be continuously monitored using microdataloggers. Comparisons can be made to ASHRAE Standard 55 *Thermal Environmental Conditions for Human Occupancy* (ASHRAE 55, 2013), which specifies a thermal comfort zone defined by a number of thermal parameters. Dataloggers can run around \$100 per unit (with multiple-input capability); handheld sensors without datalogging capabilities run from \$50-\$500. The learning curve for either type is nominal.

- Infrared temperature sensors: Passive house designs aim for an average room air temperature that does not differ by more than 7.56°F (4.2°C) when compared to the average surface temperature of the enclosure. Indoor surface temperatures can be easily measured with IR temperature sensors that cost \$35-\$60 and involve no learning curve.

- Sample construction assemblies: Cut-away sample assemblies for wall, window, roof, or floor construction—essentially a kit of parts—can facilitate visualization of how materials are assembled, the proper location of the air barrier, and how thermal bridging can be avoided. An assembly might cost less than \$50 (or be donated by a local builder).

2.2. Software

- Passive House Planning Protocol (PHPP): Is an Excel-based tool that provides the basis for verification of a design proposal against the passive house standard through a series of inputs and approved calculations that yield a proposed building's heating, cooling, and primary energy demands.

- Wärme und Feuchteinstationär (WUFI): Is PC-based software that can calculate and visualize heat and moisture transfer in an envelope assembly over time. It considers vapor diffusion and liquid transport in building materials, as well as sensible heat transfer.

- WUFI-Passive: Is a recently-released modelling tool combining the capabilities of both static PHPP analysis and the dynamic modelling of WUFI. Pre-packaged input decks, extracted from sample software runs, would allow students to play with design variables without the effort of from-scratch data input. Collaboration between the Fraunhofer Institute, PHIUS, and Owens Corning produced this tool specifically for North American climates. Fraunhofer provides free trials for institutions conducting research and deep discounts for classes.

- THERM: Is PC-based software that models heat-transfer effects through building components where thermal bridging may be of concern.

The skillful use of a combination of equipment and software in appropriate educational settings will allow a student to spend a reasonable amount of time to gain an understanding of a given concept or principle. Beyond

this awareness phase, students would then learn to apply passive house strategies to their own design projects to reach the ability plateau.

3.0 CURRENT EFFORTS AT UNIVERSITIES

Passive house education efforts at Miami University (seminar), North Dakota State University (design-build), and the University of Oregon (seminar) were described in a 2013 paper (Kwok et al.). The delivery process for curricular innovation reveals several barriers to embedding concepts into the architecture curriculum, along with a need for greater dialogue on concepts and principles, construction techniques, energy targets, and the need for collaboration among building professionals (designers, contractors, engineers, and consultants). In each case, it took a champion at each university to implement course activities into the curriculum.

3.1. Miami University

The Department of Architecture and Interior Design at Miami University (Ohio) offers two course options for students to engage in the study of passive house: a Passive and Low Energy seminar and a Passive House Malta Summer Workshop. Both elective courses are offered to graduate and undergraduate students; with enrollment comprising predominately third and fourth year architecture students and several graduate students. The courses are run in succession with the intent that students who enroll in the Passive and Low Energy Seminar will follow up the experience with the Malta workshop. Both courses are relatively new offerings in the department and are entering their second year of instruction.

The Passive and Low Energy course meets three days a week for 50 minutes each session. The focus of the course is passive house design as a means for achieving net-zero construction. Students are instructed in the importance of airtight construction, super-insulation, thermal-bridge-free design, solar heat gain, ventilation, and hot water systems to achieve low- and net-zero results. Students also explore passive house energy modeling software (PHPP or WUFI-Passive)

The Passive House Malta Summer Workshop is conducted every other summer. In 2011, seventeen students traveled to the 15th International Passive House Conference in Innsbruck, Austria for one week, and then to the island of Malta for three weeks. In Innsbruck, students attended an introductory full-day seminar, held by Dr. Wolfgang Feist, one of the founders of the Passive House Institute in Germany. Students were expected to attend all general sessions of the conference, workshops held during the conference, attend the building trade show, and participate in an all-day building tour of various passive house projects under development in the area. Following the conference, the class proceeded to the island of Malta, where it studied traditional Maltese stone construction and current concrete construction methodologies. Students were introduced to heat transfer analysis software and were required to analyze the thermal qualities of current Maltese construction and offer alternative solutions to improve the thermal performance of the construction.

3.2. North Dakota State University

In 2011, a three-semester design-build course was offered at NDSU with the goal of designing, constructing, exhibiting, certifying, and occupying a passive house structure. Students engaged several clients, consultants, governing authorities, manufacturers, and researchers. They provided design and energy solutions to prospective clients on four different sites using the Passive House Planning Package (PHPP) and full-scale construction as primary modes of investigation through various stages of design and implementation. One of these projects moved forward to pre-certification and construction.

In the design studio component (one studio of six credits with 22 students), students researched, analyzed, and designed through various-scale investigations, completing typical phases of a design project such as schematic design, design development, and construction documentation and specifications. Experts and studio faculty introduced building science and passive house principles during visits to certified buildings in the region. In addition to PHPP, Athena and USGBC's LEED for Homes provided a comprehensive approach to evaluating environmental impacts. The studio instructor used WUFI and THERM to further the energy analysis by the students. Students constructed full-scale modules of various construction systems such as structural insulated panels (SIP), double-wall stick frame, and solid wood construction to analyze super-insulated passive house performance for a cold climate.

In the construction seminars (two seminars of three credits each, with 15 students), students and studio faculty completed pre-certification of the passive house project (a cabin) with the Passive House Institute US (PHIUS). The students then constructed the 650 ft² (60 m²) cabin in St. Paul, MN at the Eco-experience Exhibit. The exhibit lasted ten days after which the students dismantled the various building modules and created installation instructions and a labelling system for re-installation at the permanent site. The modules were transported to the permanent location.

The documentation studio (one studio of six credits with 14 students) students—using the work of the Design & Construction semesters—translated months of documentation (photos, writings, models, drawings, full scale modules, and document sets) into two books.

3.3. University of Oregon

The Department of Architecture at the University of Oregon offered a four-credit seminar course in the Spring Term of 2012 called Passive House Design and Detailing. This course fulfilled an advanced technical elective requirement and was offered to undergraduate and graduate architecture students. There were two prerequisites for the course: Building Construction and Environmental Control Systems I, since the students needed a basic understanding of wood framed construction, passive strategies, thermal comfort, and heating and cooling systems to adequately engage the material. The course met twice a week on Tuesday and Thursday for 1 hour and 50 minutes over the ten-week term. Typically, a lecture on a specific aspect of the passive house concept was given on Tuesday; on Thursday, the students were assigned an in-class activity that complemented Tuesday's lecture material. At the end of class on Thursday, a take-home exercise, which the students completed in pairs, was assigned and due the following week. The last four weeks of the term, the students worked in pairs to develop the design of a small passive house for a hypothetical site in Eugene, Oregon. In lieu of in-class activities during the final four weeks, in-class checkpoints for the final project kept the students on track. Faculty and local professionals attended a poster review session on the last day of class to provide feedback to the students on their final projects.

Throughout the term, the seminar collaborated with the Center for the Advancement of Sustainable Living (CASL), a student-initiated program at the University of Oregon. CASL is renovating a small single-family house—the CASL house—near the University of Oregon campus using passive house principles. Many of the activities and exercises during the term asked students to investigate aspects of the CASL design, including the assemblies, connections, and mechanical system. Several of the students enrolled in the seminar were also involved with the construction of this project. During one course period, the students had the opportunity to visit the CASL house and see passive house strategies implemented firsthand, including advanced framing, types and applications of insulation, and the heat recovery ventilation system. During this visit to the CASL house, a blower door test was conducted to show the students how to interpret the results.

A small grant (\$5000) for the course enabled the participation of guest speakers. The guest speakers were given a lecture topic to cover during the first hour of the course, and were asked to share examples of their own work during the second hour. In some cases, they led the week's in-class activity. Guest speakers were selected based on their experience/expertise with passive house and related software tools. All of the guest speakers were located on the west coast; most were located in Oregon or Washington and within driving distance of Eugene. For this reason, the relatively small grant went a long way.

Several students, recently minted Certified Passive House Consultants, provided support throughout the term. These students had a strong understanding of passive house principles and the associated software and were able to provide support to the seminar students during activities and exercises, as well as assist in the development of course materials.

4.0 BARRIERS AND SOLUTIONS TO IMPLEMENTATION

Infusing the curriculum through seminars, lectures, and design-build studios, reveals several barriers. A few of the barriers and solutions are described in this section.

4.1. Curricular inertia

University teaching schedules and studio programs are often set a year in advance. Teaching loads are often already heavy, particularly in departments where faculty teach design studio, required lecture courses, and electives. It is often incumbent on an interested faculty member to "relinquish" a current elective to champion a new course or studio topic. It can easily take 3 to 4 years to start a new program, specialization, or emphasis within a department of architecture. What can be done in the short term?

4.2. Institutional culture

Passive house activities are generally most easily infused in curricula that strike a balance between theory and application. Passive house construction techniques—super insulation, triple glazed windows, minimal heating systems (depending on climate), ventilation and extreme air tightness—challenge the way that building envelopes have been traditionally designed. In architecture departments, where the aesthetic appeal of a design is the predominate studio criteria, getting faculty and students to embrace strategies that will ensure higher building performance is often a challenge. There is a lot of material to cover in a short amount of time. Again, if there are a number of passive house champions on the faculty and administration, there is less likelihood of the topic becoming marginalized. Evocative assignments and guest lectures in

building construction, structures, and enclosure classes that challenge (and inspire) students to dig deeper, can be successful.

Another barrier to the implementation of passive house instruction in some departments is the “bias/influence” that LEED has in the minds of some faculty and many students. Sending a cadre of students and faculty through the CPHC training program is an excellent way to jumpstart a change in culture. Students gain more useful, applied knowledge through the testing and training requirements associated with becoming a CHPC. Energy standards obtained through branded certification processes hold great allure to students and many feel that obtaining LEED accreditation will improve their chances for employment upon graduation. Actively engaging another certification process is simply a huge barrier for many. Unfortunately, there is a substantial difference between LEED and passive house certifications. Passive house is based on collective building energy performance rather than point acquisition; LEED addresses water and materials in addition to energy. Moving toward high-performance building outcomes would be enhanced by knowledge of both LEED and passive house.

4.3. Tools and expertise

A working knowledge of passive house concepts and techniques, and familiarity with the PHPP energy modeling or WUFI-Passive software, is difficult to accomplish in a 16-week semester course (or a 10-week quarter) that meets just 2–3 hours per week. A companion studio that runs parallel with a lecture/seminar course would be beneficial so students could apply passive house concepts to their studio design projects and test them using the PHPP. Faculty expertise (see below) is necessary to support such implementations—along with resources to obtain the software.

Also, many schools lack the funding to support large equipment purchases such as a blower door. Often the energy management department of a local utility company is happy to demonstrate blower door testing and thermal imaging. Portable tool lending libraries (dataloggers, etc.) may also be supported by local utilities. Institutional seed grants to acquire tools for sustainability projects are often available.

4.4. Faculty expertise

Not many faculty are trained as a CPHC or have explored passive house enclosure details in depth to acquire a critical understanding of the issues. Additionally, students can have inconsistent preparation in building science fundamentals. Because of the high level of knowledge and software expertise required to design passive house buildings, guest speakers can be a critical component of a course’s success. Their first hand experience with passive house projects and the unique perspective regarding their particular discipline and expertise can be quite powerful.

Design-build studios that require full-scale construction can strain limited resources and personnel. Even though design-build can be greatly beneficial in creating a deep understanding of energy and performance issues, there are very few legal frameworks that allow such projects to be covered under practice laws such as general and professional liability insurance.

There are two main schools of thought regarding introduction of a new educational paradigm: a) jump in and just do it (many Solar Decathlon projects happen this way) with teams learning along the way, or; b) start by gradually building up equipment and software resources, inviting guest speakers, and hosting a one-day workshop and tour (if possible).

CONCLUSIONS

A dialogue on passive house concepts and principles, construction techniques, and energy targets, establishes a need for collaboration among building professionals (designers, contractors, engineers, and consultants)—the ultimate “integrated design practice.” A curriculum that infuses passive house concepts and principles is a means of exposing students to analysis tools like WUFI or a blower door, but also opens the door to a dialogue on ways to infuse the curriculum with new courses that address the 2030 Challenge. The focus of this paper was on the academic environment, rather than mimicking professional training. We believe that courses and activities that provide tangible methods and tools for students to learn at multiple scales, is the most effective way of moving the curriculum. This paper represents a point-in-time snapshot of available passive house tools and resources. As new research emerges, the concepts and principles should remain the same, but improvements in building technologies (materials, HRV/ERVs, sealants, vapor and air barriers, and so on) will be important for students to familiarize themselves with these as they move into practice.

ACKNOWLEDGEMENTS

Many people and organizations have contributed knowledge, materials, ideas, and opinions to the passive house movement. We acknowledge the faculty (and administration) at institutions that have taken steps to start up new courses and activities.

REFERENCES

- ANSI/ASHRAE. 2013. Standard 55-2013: *Thermal Environmental Conditions for Human Occupancy*, American Society of Heating, Refrigerating and Air-Conditioning Engineers, Inc. Atlanta, GA.
- ANSI/ASHRAE. 2013. Standard 62.2-2013: *Ventilation and Acceptable Indoor Air Quality in Low-Rise Residential Buildings*. American Society of Heating, Refrigerating and Air-Conditioning Engineers, Inc. Atlanta, GA.
- Architecture 2030. 2014. *The 2030 challenge*. http://architecture2030.org/2030_challenge/the_2030_challenge Accessed December 2014.
- Autodesk. 2014. *Autodesk Revit products*. <http://knowledge.autodesk.com/support/revit-products> Accessed December 2014.
- Kwok, Alison, M. Hogan, M. Rogero, and M. Srivastava, 2013. *Passive aggressive: infusing passive house principles into the curriculum*, Proceedings from the ARCC Spring Research Conference, Charlotte, North Carolina, March 27–30, 2013, 321-329p.
- PHIUS. 2014a. *What is passive building?* <http://www.phius.org/what-is-passive-building/the-principles>. Passive House Institute US. Accessed December 2014.
- PHIUS. 2014b. *PHIUS CPHC training program*. <http://www.phius.org/get-professional-training/certified-passive-house-consultant-cphc-training/program-overview> Passive House Institute US. Accessed December 2014.
- Stevens, Garry. 2014. *Why architecture should leave the university*. <http://www.archsoc.com/kcas/leaveuniversity.html> Accessed December 2014.
- USGBC. 2014. *LEED rating systems*. <http://www.usgbc.org/leed> US Green Building Council. Accessed December 2014.

Universal design in architectural education: Who is doing it? How is it being done?

Megan Basnak¹, Beth Tauke¹, Sue Weidemann¹

¹IDEA Center, University at Buffalo—State University of New York, Buffalo, NY

ABSTRACT: The World Health Organization estimates that over one billion people, or 15% of the world's population, have some form of disability. As demographics change and the world's population continues to age, this number is expected to dramatically increase. In response to this global trend, many designers, advocates, and anyone interested in making physical and visual environments more usable for people with diverse backgrounds and abilities have adopted the philosophy known as universal design (UD), inclusive design, or design for all. Despite the demonstrated need for designers who are knowledgeable in UD theory and practice, it seems that architecture programs in U.S. universities have been slow to adequately incorporate UD into their curricula.

In an effort to gain a better understanding of the current state of UD content in architecture curricula, researchers distributed an online survey to architectural educators and administrators in 120 U.S. institutions with accredited degree programs. The study, sponsored by the National Institute on Disability and Rehabilitation Research (NIDRR), consisted of qualitative and quantitative questions that sought information related to the understanding, attitudes, and incorporation of UD into each participant's curriculum.

Responses were obtained from 463 participants representing 104 of the 120 surveyed schools. Quantitative analyses found relationships between perceived attitudes of administrators, faculty, and students and the effectiveness of UD components in a program. Qualitative findings were rich and complex, revealing great variability across schools, in terms of how, when (course level), and the degree to which UD aspects were incorporated into programs.

Implications for educational programs, as well as future research, will be discussed.

KEYWORDS: Inclusive Design, Universal Design, Design Education, Survey Research, Design Curriculum

INTRODUCTION

Universal design (UD), sometimes called inclusive design or design-for-all, is "a process that enables and empowers a diverse population by improving human performance, health and wellness, and social participation" (Steinfeld and Maisel 2012, 29). Inclusive processes aimed at helping all of us to experience the full benefits of products, environments, communications, systems, and policies regardless of our age, size, situation, and abilities have been around since the mid-1970s (Welch 1995, 1-4). With roots in the Civil Rights and Disability Rights movements, UD is a socially focused design philosophy grounded in democratic values of nondiscrimination, equal opportunity, and personal empowerment (Tauke 2008).

UD is a growing trend for a number of reasons:

1. *Demographics are changing.* Over the next twenty years, the older population will increase by more than 50%. The World Health Organization estimates that over one billion people, or 15% of the world's population, currently have some form of disability. As demographics change, this number will dramatically increase. Universally designed products, systems, and environments that empower this growing sector will be in greater demand in the coming years.
2. *Social sustainability is a natural part of the environmental sustainability movement.* Social sustainability focuses on the development of programs, processes, and products that promote social interaction and cultural enrichment. It emphasizes protecting the vulnerable, respecting social diversity, and ensuring that we all put priority on social capital. Social sustainability relates to how we make choices that affect other humans in our 'global community'. UD is the key component of social sustainability and is receiving serious attention from the proponents of this movement.
3. *Mass customization is making it easier to develop universally designed solutions.* Mass customization is the application of flexible, computer-aided manufacturing systems to produce customized goods and services. Through this process, products that were once standardized are now able to change to meet the needs of individuals at the same low unit costs of mass production. This universally designed approach to manufacturing makes design for all more possible and affordable.
4. *Digital technologies are augmenting or eliminating static solutions to dynamic conditions.* Many

products and systems that previously were fixed entities are now active. For example, Global Positioning Systems (GPS) augment environmental signage and provide individual navigation and information that is specific to each user's needs. Dynamic and personalized products and systems add a critical layer of usability for everyone.

5. *World economies are changing.* The International Monetary Fund World Economic Outlook states that "although downside risks have diminished overall, lower-than-expected inflation poses risks for advanced economies, there is increased financial volatility in emerging market economies, and increases in the cost of capital will likely dampen investment and weigh on growth"(IMF 2014). This forecast moves attention towards smart conservation—ways to save money that maintain or improve standards of living. As a result, businesses and governments are looking at processes and approaches that change patterns of waste. UD, then, becomes part of the solution. For example, the cost of assisted living and nursing facility care is expensive, both for national health providers and for individuals. Vast amounts of money will be saved if people can stay in their houses or apartments longer because they are universally designed.
6. *Attitudes about consumption are changing.* The concepts of 'planned obsolescence' and 'consumer waste' so prevalent in the later part of the twentieth century are giving way to more prudent and conscientious notions of consumption. Rising energy costs and the slowdown in the world economy have encouraged consumers to rethink their purchasing patterns. Quality over quantity is making a comeback. Universally designed features save money in the end, and elevate the quality of living for all.

To account for these trends, design fields must respond by adapting their methods of practice to meet the changing demands of their clients. University education is the key to changing professional culture in the design fields. Design professionals develop their professional interests, values, and priorities early in their careers. Students who are exposed to UD concepts and practices during their architectural education are more likely to accept UD as a key aspect of good design than those who are exposed later in professional practice, which currently does not put a high priority on UD. Knowing the overall state of teaching practices in teaching UD is an essential step in improving education in this field.

1.0 UD EDUCATION IN LITERATURE

1.1. Literature overview

To date, the literature does not document the current state of UD content in design programs. Existing literature examines barriers to UD education and outlines possible strategies for implementation of UD content into design curricula, but discusses these topics only in general terms. As a result, faculty and administrators must make decisions on UD content based on assumptions and beliefs rather than facts. In addition, this lack of information prevents possible sharing of valuable information and course materials between disciplines and schools. The following two sections address areas related to UD and architectural education documented in the literature.

1.2. Barriers to UD education

Studies have found a number of reasons why design programs have been slow to incorporate UD into their curricula, the most cited being a general lack of understanding of what the concept means and/or advocates. UD often is misunderstood as a synonym for accessible design and, therefore, is used interchangeably by design instructors (Welch and Jones 2001, 51.4). Additionally, the philosophy sometimes is referred to as a utopian notion (De Cauwer et al. 2009). 'Utopian' has both negative and positive connotations, and in the case of UD, design faculty have been wary of adopting a philosophy based on utopian ideals (Steinfeld and Tauke 2002). The topic is viewed by some as unscientific and, although considered a set of good intentions, is something that is difficult to achieve because it is not possible to completely adapt the environment to all users' needs. In this view, it is felt that, at best, "designers can only strive to limit the damage" (De Cauwer et al. 2009).

In addition to skepticism related to the validity of UD as an area of discourse, another challenge cited is the nature of university design education in general. Given the fact that university education is research-based and academic, many feel that design education should enable students to integrate 'necessary' concepts and standards into their work. While UD has the potential to be one of those concepts, in contrast to accessibility standards, it is not directive (De Cauwer et al. 2009). Moreover, faculty resistant to change often articulate their discomfort with the argument that design curricula are overloaded and that UD-related considerations are best learned post-graduation in the professional setting (Welch and Jones 2001, 51.20).

A third challenge to incorporating UD content in design curricula is the frequent negative association of the term with regulation. Historically, architecture faculty have approached the topic of accessibility, the precursor to UD, as "one extra piece to be fit into the design puzzle" (De Cauwer et al. 2009). As a result, faculty and students view UD as something that is added instead of incorporated and often, "students...fear

social science might straitjacket their architectural creativity” (Lifchez 1986, 184). Faculty resistant to change also equate UD with “ugly ramps and homogeneous spaces” (Welch and Jones 2001, 51.20). According to Raymond Lifchez, “client accommodation is not merely the third element in design, alongside aesthetics and technology, but is in fact the context within which all factors of architectural design must be placed” (Lifchez 1986, 180).

1.3. Implementation strategies for UD education

In an effort to overcome the barriers to implementation, design faculty around the world have adopted various strategies to incorporate UD into their architectural curricula. Most curricular responses are classified into one of two categories: injection strategies or infusion strategies. Injection strategies often are attempted before infusion strategies because their benefits tend to outweigh any potential shortfalls. Examples of injection methods include incorporating a stand-alone UD unit into a course, devoting an entire course to UD, or offering a one-time event/workshop dedicated to UD (Welch and Jones 2001, 51.10-51.14). Infusion strategies are implemented when injection strategies are successful and faculty seek to “diminish the potentially marginal status of the course content... and illustrate to students the interconnectedness of factors impacting design, while challenging the students to internalize and apply their understanding to projects and tests in much the same manner as they do in a design problem” (Welch and Jones 2001, 51.15). Infusion strategies include infusion of UD materials into a subject area course, a studio problem focused on UD, a single year of the curriculum devoted to UD, and incorporation of UD into the entire design curriculum. Unlike injection-type curricular responses, infusion responses require a critical mass of faculty members well versed in and dedicated to the topic (Welch and Jones 2001, 51.15).

Using injection and infusion methods, several design programs in the United States and internationally have successfully been able to incorporate UD into their curricula. Methods including empathic modeling in a Human Factors course, teaching the Principles of UD as a special topic in a large studio, and inviting users with diverse backgrounds and abilities to speak to classes all are examples of how faculty have attempted to introduce students to UD concepts (Altay and Demirkan 2014). While a small number of design-based academic programs offer a concentration focused on UD, such as the Inclusive Design Graduate Research Group at the University at Buffalo—State University of New York, little acknowledgement of these programs in literature exists, making it difficult to understand the extent to which UD is infused in design curricula (Tauke, Steinfeld, and Basnak 2014). One documented study examining student and instructors’ attitudes toward UD focused only on students and faculty in the Department of Interior Architecture & Environmental Design at Bilkent University in Ankara, Turkey. Although the survey provided valuable data related to the effectiveness of certain teaching methodologies in creating awareness of UD in students, the limited survey population of only 23 instructors and 79 fourth year students failed to give a comprehensive overview of infusion not only in the school as a whole, but in the region, country, and world (Afacan 2011).

1.4. Summary

Despite the demonstrated need for designers who are knowledgeable in UD theory and practice, based on the existing literature, it seems that architecture programs, particularly in the United States, have been slow to incorporate UD into their curricula. There is little documentation examining the breadth and quality of UD education in design programs. In an effort to gain a better understanding of the state of UD education in architecture schools in the United States, researchers conducted an online survey of architecture administrators and faculty from institutions with accredited degree programs.

2.0. METHODOLOGY

2.1. Sample

Architectural faculty and administrators in 120 accredited degree programs in the United States were targeted for the survey. Principal investigators compiled a list of potential schools from which to contact faculty and administrators for the survey using an online directory of accredited degree programs provided by the Association of Collegiate Schools of Architecture. Based on this list, the names and email addresses of architecture faculty and administrators were gathered from each school’s online faculty and staff directory. Over 4,400 individuals were invited via email to take the online survey.

2.2. Instrument

The survey consisted of questions that sought both quantitative and qualitative data. Questions included both multiple choice and open-ended answer styles and covered three major content areas: 1) background information about the participant, 2) attitudes and understanding related to UD, and 3) the nature of incorporation of UD into the curriculum. The first content area asked participants to identify their institution type (public, private, etc.) and role in the program. The second content area sought information related to attitudes and understanding of UD such as the participant’s understanding of UD and general faculty, student, and administrator attitudes toward UD in their programs. The third content area pursued information more related to UD’s role in the curriculum including whether or not it is addressed, at what level it is addressed, in what courses it is addressed, and general ways in which it is incorporated. Questions also

sought information related to how effective the participant felt UD components were in their curriculum and asked for suggestions for increasing UD's relevancy not only in their program, but in architectural education in general. The survey concluded by giving participants the option to provide their institution's information in order to allow the investigators to track school response rate (number of schools responded versus number contacted).

2.3. Analysis

Survey Monkey, an online cloud-based company, was used to collect survey responses. Responses were downloaded into Microsoft Excel and SPSS. Other than an I.P. address, Survey Monkey recorded no other identifying information from participants.

Two data sets were created from the survey responses; one consisted of the responses to all items by the *individuals* who completed the survey. The other was a set of responses to all quantitative items for the *schools*. Because there were differing numbers of respondents from each school, a mean score (for all respondents within a school) was computed for each quantitative item. This was done to avoid over-representation by schools with large numbers of respondents.

Descriptive, comparative, and correlational analyses were used to provide information about two primary questions: 1) Who is teaching UD? and 2) How are they doing it?

3.0. RESULTS

3.1. Sample

Responses to the survey were obtained from 463 participants representing 104 of the 120 surveyed schools. Based on identifying information provided by survey participants, schools from all six ACSA-defined regions—Northeast, Mid-Atlantic, West, Gulf, West Central, and East Central—were represented in the survey results. The region with the lowest response rate (in terms of number of schools represented versus number of schools contacted) was the Gulf region, with a response rate of 63% (10 out of 16 schools). The East Central region had the highest response rate of 100%, with participant responses from 20 schools out of a possible 20 schools contacted.

Of the 463 respondents, 70% reported that they were faculty members and 12% identified themselves as administrators. In regards to the level of understanding of UD, 24% exhibited a high level of understanding and 52% exhibited an adequate level of understanding. Only 4.8% were not aware of the term or did not know what it was. However, 18.8% made no response, or wrote in something that was not relevant to the question.

3.2. To what extent do respondents feel that UD material is being incorporated into design education at their school?

Individuals. Of the individual respondents, 68.8% said that UD *was addressed* in their program's curriculum, 18% said it was *not addressed*, and 13.2% indicated that they did not know whether or not it was addressed. Of those respondents who said that UD was not addressed, only one-third reported that there was an interest in incorporating it into the curriculum.

When looking at this question by respondent role, Table 1 below shows that the more 'experienced' respondents were more likely to say that UD was addressed in their curriculum.

Table 1: Is universal design addressed in your curriculum?

Role of respondent		Administrator	Tenured faculty member	Tenure-track faculty member	Adjunct faculty member
Yes	N	46	118	57	42
	%	85.2%	75.6%	68.7%	51.2%
No	N	6	26	15	21
	%	11.1%	16.7%	18.1%	25.6%
Don't know	N	2	12	11	19
	%	3.7%	7.7%	13.3%	23.2%
Total	N	54	156	83	82

Schools. When the individual responses for each school were averaged to create a 'school score', we found that 69% (70 schools) had unanimous agreement among their respondents that UD was addressed in their curriculum. Twenty three percent (23 schools) gave mixed responses (yes and no), and 8% (8 schools) said that UD was not present.

From the aggregated school data, we could learn if there were other differences, e.g. between ACSA regions, or between public and private schools, in terms of whether or not UD was addressed in their curriculum.

No significant difference (t-tests for independent samples) was found for the comparison of *public to private schools*, in terms of UD being addressed in their school. Nor were there any significant differences (one way anova) among the six ACSA regions. This suggests uniformity in level of UD presence in curricula across the country.

3.3. Attitudes about universal design

Respondents were asked to describe the attitude of their administrators, faculty, and students about UD, on a five-point scale (from very positive to very negative).

Individuals. Individuals responded positively, with very little difference in terms of the groups about which they were asked. Figure one below shows that, in general, respondents felt that others in their program were quite positive about UD. (Note: The figure shows the percentage of people for each response choice.)

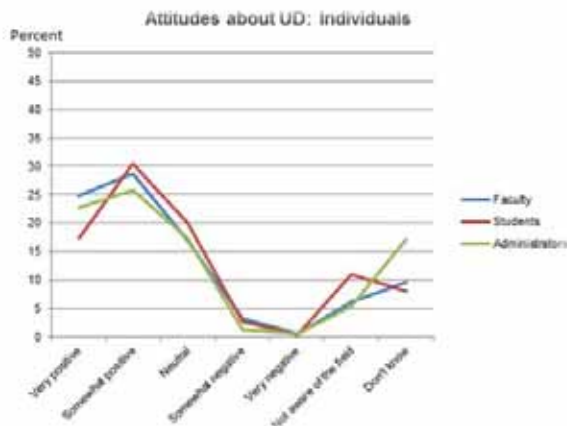

Figure 1: Attitudes about universal design (Individual respondents)

It is also important to note the relatively large percentage of people who responded that they were not aware of the field, or were not aware of their colleagues' feelings.

Schools. When asked about administrator, faculty, and student attitudes toward the concept of UD, responses showed that faculty held the most positive attitudes, with students and administrators having somewhat less positive attitudes.

3.4. How is UD material being taught and/or incorporated into design education?

The information about where UD is covered in the curriculum proved to be quite complex. One way to understand it is to look at what grade level UD material is taught and/or incorporated into the curriculum. Table 2 below is a summary of the degree to which UD education is present within the program curriculum. Out of the 104 schools surveyed, data on the level of infusion was obtained from 72 schools. Some programs covered it only at the early undergraduate level, others only in the graduate level, while others had a mix of locations in which it was covered. As can be seen, most schools addressed UD *only* in a portion of their programs. Only 8% of the schools addressed UD throughout their entire program.

Table 2: Presence of universal design in curriculum

Level of Presence	# of Schools	Percent
1st or 2nd year <u>OR</u> 3rd, 4th or 5th year <u>OR</u> grad	55	76.4
Mixed (lower & upper) <u>OR</u> (upper & grad <u>OR</u> lower & grad)	11	15.3
Infused throughout	6	8.3

When asked how effective the UD components were in their curriculum, only 8% said they were very effective, and over 18% said they were 'neutral', 'ineffective', or 'didn't know'. Figure 2 below shows the detailed findings for individual respondents. This clearly suggests that only about one-third of respondents who have UD content incorporated into their curriculum felt that the content was at least moderately effective.

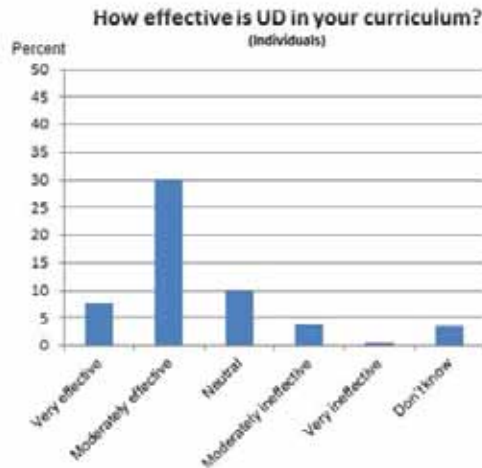

Figure 2: Effectiveness of UD in curriculum (Individual respondents)

3.5. THE RELATIONSHIP BETWEEN ATTITUDES AND EFFECTIVENESS OF UD

It is interesting to look at the relationships between the three questions asking people to indicate what attitudes about UD would be for other people in their program and how effective they thought the UD components in their curriculum were. Table 3 below shows correlations among these questions for both the individual responses and for the school scores.

Table 3: Correlations among attitudes and effectiveness of UD components

	Correlations: Individuals (N~300)			Correlations: School scores (N~93)		
	UD Effectiveness	Faculty Attitudes	Student Attitudes	UD Effectiveness	Faculty Attitudes	Student Attitudes
Faculty	.33**			.36**		
Students	.36**	.55**		0.14	.35**	
Administrators	.33**	.62**	.41**	0.15	.29**	.52**

*. Pearson Correlation is significant at the 0.05 level (2-tailed).

**. Pearson Correlation is significant at the 0.01 level (2-tailed).

For the individual respondents, there are significant relationships between attitudes and UD effectiveness for all items; however, for school scores, only faculty attitudes are positively related to UD effectiveness. But the most parsimonious question to ask is: Which, if any, of the attitude items can significantly predict the

perceived effectiveness of UD components in a program? A stepwise linear regression analysis was done for both data sets. In both cases, *only* faculty attitudes were a significant predictor of level of UD effectiveness in the program.

In addition to the topics discussed above, the survey also sought information related to courses in which UD content is incorporated, suggestions for increasing relevancy of UD in program-specific design curricula, and suggestions for increasing the relevancy of UD in architectural education overall. These answers were provided through open-ended questions; these questions are currently being analyzed. Results will be shared at a future date.

DISCUSSION

Despite the lack of existing literature documenting the incorporation of universal design into university-level architectural education, this study found that a significant number of accredited programs in the United States address the philosophy somewhere in their curriculum. Sixty-nine percent of both individual respondents and aggregated school responses indicated that their curricula addressed UD. Based on preliminary and anecdotal evidence of UD content in architecture programs, this value was higher than expected. Although 76% of survey respondents exhibited adequate to high levels of understanding of the term UD, the higher-than-expected value for incorporation may be as a result of respondents mistakenly identifying accessibility curricular elements as UD. Accessible design is a *subset* of UD. UD considers all human-environment conditions, especially those that typically are overlooked. While accessible design often is noticeable in a stigmatizing way, Universal Design blends in with the mainstream.

In addition to the higher than expected extent of incorporation of UD curricular elements into architectural education, the study also found that perceived attitudes of administrators, faculty, and students toward UD were more positive than expected in comparison to what we saw in the existing literature. Almost half of all individuals responded that they felt their students, faculty, and administrators had at least somewhat positive attitudes toward UD. The results showed that attitudes that are more positive are strongly correlated with a positive presence of UD in the curriculum and higher levels of understanding of the philosophy.

Infusion of UD content throughout the curriculum demonstrates a school's exceptional commitment to UD as a component of architectural education. Of the 69% of schools that reported incorporating UD content into their curricula, 8% (6 schools) reported full infusion. Again, this value is higher than expected based on preliminary and anecdotal evidence of UD content in architecture programs and the newness of this area of research and field of study.

RECOMMENDATIONS FOR FUTURE RESEARCH

Overall, this research found that UD content is more prevalent in architecture curricula in the United States than we expected. While this finding is important, additional research is needed to explore the level of understanding of the specifics of UD. This would help to ensure that respondents mistakenly identifying UD course content as synonymous with accessibility would not inflate incorporation numbers.

While faculty and administrator responses are important in assessing the presence and effectiveness of UD in architectural programs, knowledge of student response is essential as well. Additional research focused on student understanding and attitudes about UD would provide insight into the success of existing methods of UD instruction and would provide an overview of the current state of UD knowledge amongst students.

In addition, researchers need to distribute a revised and more comprehensive survey of this preliminary study to those who are involved in education in other design areas, including visual communication, industrial design, interior design, urban design, and landscape architecture. This would allow researchers to gain a broader understanding of UD's relationship with design education and may provide valuable insight into ways in which information can be shared across design disciplines.

ACKNOWLEDGEMENTS

The research discussed in this document was in part funded by the Department of Education, National Institute on Disability and Rehabilitation Research (NIDRR) grant number H133E100002. However, this content does not necessarily represent the policy of the Department of Education, and you should not assume endorsement by the Federal Government. Also, we would like to particularly thank all of the architecture faculty and administrators who responded to the survey and provided invaluable insight into the state of universal design education in architectural programs across the United States.

REFERENCES

- Afacan, Yasemin. 2011. "Teaching universal design: an empirical research in interior architecture." *Procedia - Social and Behavioral Sciences* no. 15 (0):3185-3192. doi: <http://dx.doi.org/10.1016/j.sbspro.2011.04.269>.
- Altay, Burçak, and Halime Demirkan. 2014. "Inclusive design: developing students' knowledge and attitude through empathic modelling." *International Journal of Inclusive Education* no. 18 (2):196-217. doi: 10.1080/13603116.2013.764933.
- De Cauwer, Peter, Mieke Clement, Herman Buelens, and Ann Heylighen. 2009. Four reasons not to teach inclusive design. Paper read at Proceedings of Include.
- IMF. 2014. World Economic Outlook (WEO). <http://www.imf.org/external/pubs/ft/weo/2014/01/>.
- Lifchez, Raymond. 1986. *Rethinking architecture: Design students and physically disabled people*: Univ of California Press.
- Steinfeld, Edward, and Jordana L. Maisel. 2012. *Universal Design: Creating Inclusive Environments*. Hoboken, New Jersey: John Wiley & Sons, Inc.
- Steinfeld, Edward, and Beth Tauke. 2002. "Universal designing." *Universal design* no. 17:165-190.
- Tauke, Beth. 2008. Universal Design = Good Design for New York. New York City Mayor's Office: Creating a Livable City for All Ages Symposium, The Role of Universal Design and Placemaking.
- Tauke, Beth, Edward Steinfeld, and Megan Basnak. 2014. Challenges and Opportunities for Inclusive Design in Graduate Architecture. Paper read at International Conference on Universal Design.
- Welch, P, and S Jones. 2001. "Advances in universal design education in the united states." *Universal design handbook*:51.1-51.24.
- Welch, Polly. 1995. *Strategies for teaching universal design*: Mig Communications.

GENERAL

Cuba, historic preservation: Integrated community and policy

Emily Dallmeyer¹

¹The University of North Carolina at Charlotte, Charlotte, NC

ABSTRACT: As an island nation where tourism is essential to the economy, Cuba relies on its architectural heritage to be the backdrop and foundation of that industry. Even before tourism played such a large role, Cubans fiercely valued their built heritage. The Office of the City Historian organizes preservation efforts in Havana and has consistently prioritized the needs of the local population while carrying out preservation projects. Funding generated by completed projects achieves preservation goals as well as supports social projects through restoring buildings to house tourism functions and to house programs that address the needs of the neighborhood. Havana's experiences reveal a model of sustaining the local population and supporting social projects through tourism.

The objective of this research is to better understand the circular relationship between preservation, social projects and economics that exists in Havana, Cuba. Through on site interviews and project visits this research analyzes the Cuban policy model. While Cuba has a unique political situation, the integration of functions that at first glance, seem unrelated to the work of preservation are part of the strength of the program. The combination of job – training programs, health care functions, and community involvement turn the luxury of preservation into a needed tool that serves the community. By serving the population that has the greatest need, the Office of the City Historian has built a support network. An analysis of these relationships sheds light on the connection between built heritage and a living, breathing community.

The practice of precedent research is core to the practice of architecture. This particular precedent reveals an opportunity in the practice of preservation. Through analyzing this model, this research builds a foundation for future innovation.

KEYWORDS: Cuba, Historic Preservation, Integrated Development

INTRODUCTION

Though founded over twenty years before the Revolution in Cuba, the Office of the City Historian of Havana has incorporated social themes crucial to the Revolution while preserving the tangible and intangible elements of Old Havana's heritage. Through the integration of disparate priorities, the Office of the City Historian has built a system that ties preservation efforts to the delivery of social services, which turns preservation from an apparent luxury into a tool that serves the community. The system relies on accomplishing two or more goals through one project. The conversion from luxury to necessary tool is only possible because preservation and non-preservation activities are managed by the Office of the City Historian through what it calls Integral Development Management. The Office of the City Historian enjoys the autonomy to orchestrate so many different projects because it has the legal authority to self-finance through the corporation Habaguanex, instead of being funded by the central government. This is a unique arrangement in Cuba. The investment of funds into projects that are primarily for tourists and foreign businesses is necessary to attract them to Cuba to spend money that can then be invested in preservation and social projects. However, the juxtaposition of tourism interests with the extreme needs of the local population can be jarring. In this paper, I will argue that by employing a strategy that looks at Old Havana holistically, instead of addressing issues in isolation, the Office of the City Historian has served multiple priorities concurrently. I will argue this by showing how its unique funding model benefits from tourism, as well as promotes tourism, provides social services and training, all while preserving the built environment.

1.0 RESEARCH METHODOLOGY

This research is based on extensive secondary and primary source literature as well as travel to Cuba in June 2014 to conduct interviews with historic preservation professionals, architects, professors, and conservators. These interviews, in combination with tours of significant sites, self-directed exploration of the

city, and contextualizing reading before and after this travel forms the foundation of my research. I use the term preservation as the umbrella that includes a range of intervention strategies, including preservation, restoration, and re-creation of historic elements.

1.1. Setting the scene

The Office of the City Historian did not have its current social focus from its inception. Founded in 1938 by Emilio Roig de Leuchsenring, early preservation efforts of the Office fought unsuccessfully to reverse the effects of deterioration and prior neglect (*Una Experiencia* 2006). By the time that the Office was founded the historic center was already deteriorated. The historic center, established in the early 16th century, was originally home to very wealthy citizens, but the demographics changed over the 19th century, and by the 20th century larger mansions had been subdivided in order to house multiple families. In addition, many tenement style buildings were built to house the influx of lower income families. (*Una Experiencia* 2006). Eusebio Leal Spengler succeeded Leuchsenring in 1967 as City Historian. Activity accelerated quickly in the early 1980s: in 1981 the first five-year plan for the restoration of Old Havana was established, in 1982 Old Havana and the fortifications were named a World Heritage site by UNESCO, and later that decade multiple projects were completed radiating out from the main city squares (Oficina del Historiador, 2014, *Una Experiencia* 2006). As a governmental body, the Office of the City Historian was originally funded through the government and therefore subject to fluctuations in funding based on availability of funds and prioritization, including the drastic cuts that were enacted during the rationing of the Special Period after the collapse of the Soviet Union, a key supporter of the Cuban economy.

When the Soviet Union collapsed in 1991, the Cuban economy also collapsed. The USSR and other Soviet countries had been purchasing the vast majority of Cuban exports at prices that were frequently higher than the products would have received on the open market (Gott 2004). This collapse ushered in the so-called "Special Period" wherein the Cuban government enacted strict rationing. All resources became scarce, from food to funding for projects like historic preservation. The Cuban government was forced to adapt and adjust their policies to the new reality: government workers were laid off and previously banned private businesses were encouraged instead (Gott 2004). Tourism was actively cultivated as an export that appealed to a wide range of countries. Most importantly for the Office of the City Historian, it was permitted to become self-funding.

2.0 OUT OF CRISIS, OPPORTUNITY

In response to the Cuban government's inability to support all the government's programs in the face of severe scarcity, the corporation Habaguanex was founded in 1994. Habaguanex, owned and operated by the Office of the City Historian, runs tourism based businesses in order to earn revenues in support of the Office of the City Historian's other projects. In the interest of supporting Cuban independence, Fidel Castro had previously scorned tourism asserting that Cuba should avoid becoming an "island of bartenders and chambermaids as had other Caribbean nations" (Scarpaci 2005). However the economic crisis of the 1990s required a shift in policy. The Decree Law 143 gave the Office of the City Historian legal power to own and run Habaguanex, separate from the other branches of government (*Una Experiencia* 2006). Instead of receiving funding from the central government, the Office of the City Historian is legally allowed to self-fund, unlike any other city historian office in other Cuban cities. The revenues from Habaguanex are reinvested at a rate 60% into preservation work and 40% into social projects, thereby perpetuating the activities of the Office of the City Historian without funding from the central government (Red 2012). The economic disaster of the Special Period provided the impetus to allow the Office of the City Historian to establish its financial autonomy by harnessing the funding potential of tourism.

Currently, Habaguanex manages a variety of businesses that capitalize on the opportunities of tourism. The corporation was formed in order to generate revenue for the Office of the City Historian running hotels, restaurants, and souvenir shops. In this way the Office of the City historian leverages the tourism industry in order to pursue additional preservation projects which have a threefold effect: preserving the tangible and intangible heritage of Cuba, fostering additional tourism opportunities and serving the community by providing employment opportunities and spaces for needed services. By tying these disparate interests together, the Office of the City Historian ensures that each element is necessary to and supports the others.

3.0 TOURISM, A NECESSARY EVIL?

Today, Cuba still has few resources that it can export, and tourism has become its most important industry. Cuba relies on its architecture and culture (or tangible and intangible heritage) to be the backdrop and

foundation of tourism industry. As the backdrop, architecture may not be fully engaged by tourists, in the same way that socialism creates an exciting locale, but is not necessarily understood in depth by visitors to the island (Babb 2011, 58). The romantic and colorful decay of Cuba is the setting for the adventure of travel as sold by tourism agencies, but tourists are not required to understand the architectural heritage that they are seeing. On the other hand, architecture and culture create the sense of a place in the eyes of locals as well as tourists. As such, the architectural and cultural heritage of Cuba creates the foundation, the support and the basis for the tourism industry.

As the basis for tourism, architectural heritage is something that is managed carefully. Joseph Scarpaci in his 2005 book, *Plazas and Barrios* is critical of what he describes as “[reviving] the semiotics of [Old Havana’s] colonial and exploited past [in order to market] its cityscape” (Scarpaci 2005, 203). The issue of control of image, which results in control of history, is particularly poignant in a place with such pervasive government control. Perhaps one of the more visible examples of how Habaguanex manages the image of Old Havana’s historic architecture is mansions that have been converted into hotels. For example, the Hotel Beltrán de Santa Cruz was the home of a marquis according to the Habaguanex website (Habaguanex 2015). The former mansion is made up of 11 rooms, a kitchen, dining and living rooms as well as an open courtyard. The second story rooms are reached by individual staircases and the third story includes a balcony that overlooks the central courtyard. This style of building allows airflow to every space, despite the fact that the building itself abuts its neighbors. From the street, the large doorway is typically open, but before entering what would have been the main living space any visitor must pass through what is now used as the lobby. The image included here shows the restoration the murals on the walls along the main staircase. There were multiple layers of the murals, so when the building was restored, sections of each layer were worked on and left visible as a sort of educational reveal. Without any explanation, some of the buildings history is understandable.



Figure 1: Wall in the Hotel Beltrán de Santa Cruz showing multiple layers of restored mural. Source of image: Author 2014.

The idea behind segregating this historic building from the general public is that through renting these rooms, visitors are able to engage with some of Old Havana’s history while they are supporting other preservation projects with their payment.

Part of the reason tourism is such an influential industry in Cuba is that tourists’ money is worth more than locals’ money by virtue of the dual currency system that exists in Cuba. Salaries in Cuba are paid in national pesos (CUP), but tourism based businesses price their products in convertible pesos (CUC). When CUP and CUC pesos were established they were intended to be equal, today the value of one CUC is tied to the dollar (although the exchange rate does vary), but CUP are worth 1/25 of a convertible peso (“Cuban Peso” 2014). Staple goods intended to meet the basic needs of the Cuban citizens are priced in CUPs and

price controlled: there are markets made up only of these types of goods. There are also markets selling basic goods that more expensive and difficult to obtain that are priced in CUCs (Vladimir 2014; Symmes 2010). Most businesses that cater to tourists have prices only in CUCs. Based on recent travel to Cuba, CUC prices were slightly cheaper than prices one would expect for similar products in the United States. Some restaurants, for example, were noticeably cheaper than in the United States, but when compared with salaries in CUPs, it is easy to understand why Cubans are not able to patronize those restaurants and also they are able to make a great deal more money when they have access to tips in CUCs. One former Geography teacher left teaching in order to earn more money driving a cab for tourists. At the time of the interview, a 20-minute drive would cost 10 CUC. He quoted his previous monthly salary as a teacher as equivalent to \$11 or 11 CUC (Alfredo 2014). Fostering tourism both brings in money but also has the power to warp Cuban reality. If the most lucrative career opportunities for Cubans are centered around presenting Cuba to outsiders (tourists) how much of the 'real and authentic' Cuba remains behind the presentation?

4.0 FOCUS ON COMMUNITY

The counterpoint to the hypothetical damage that tourism can inflict on Cuba are the social services that are paid for with the profits of tourism. The Office of the City Historian has taken advantage of its autonomy to prioritize not only preservation, but also to meet the needs of the local population. In fact, the same law that gave it the legal power to run tourism businesses to support its activities also charged the Office of the City Historian with taking care of the inhabitants of Old Havana. The Office was assigned "powers to adopt measures and solve, within the area of its jurisdiction, the most pressing and urgent needs of the population" (*Una Experiencia* 2006). The Office of the City Historian has actively addressed the needs of the population by folding those needs into the scope of preservation projects.

Through the practice of what the Office of the City Historian calls their Integral Development Management Strategy, the Office addresses issues of economics, social policy and preservation (*Una Experiencia* 2006). UNESCO and other international organizations praise this model for successfully addressing disparate issues concurrently. Through accomplishing multiple goals with the same projects, the Office of the City Historian is able to work efficiently and make sure that multiple stakeholders value its work. This is not a superficial connection between priorities, the examples that follow show that apparently unrelated goals become dependent on the success of one another.

The vast majority of the buildings in Old Havana were built in the early 20th century or earlier. Most of this stock is housing, but there are some key historic buildings whose programs, after restoration, focused specifically on other needs that exist in the community of Old Havana (*Una Experiencia* 2006, 36). One frequently referenced project is the Hogar Materno Infantil, a facility available to expectant mothers who either reside in Old Havana or work for the Office of the City Historian (Rodríguez 2014). There are 50 beds for pregnant women who need close medical care. The staff has the capacity to see an additional 60 patients who need daily medical and nutritional care, but do not stay in the facility (González 2010).



Figure 2: Hogar Materno Infantil is a maternity home that was offices before the Office of the City Historian and the Ministry of Public Health rehabilitated it. Source of image: Author 2014.

Originally built in 1950, the building housed the offices of social services for women and maternal health. The rehabilitation and conversion into a medical facility was the result of a partnership between the Ministerio de Salud Pública de Cuba and the Office of the City Historian, completed in 1997 (González 2010). This particular project blends restoration with social services, but is an example of prioritizing the needs of the community over strict preservation. The Hogar Materno Infantil building does not have a long, storied history, nor is it particularly architecturally significant. The services that are provided in the building, on the other hand, are extremely important and contribute to the reduction of the infant mortality rate within Old Havana.

Another project that does not fit cleanly into either the category of preservation or social services is Our Lady of Belén Convent and Church. This convent, built between 1712 and 1718 was run as a “convalescent home and poor house by the Order of the Bethlehem ... nuns.” The Jesuits enlarged the complex in the 18th and 19th century, but it was abandoned in 1925 (Our Lady 2014). The convent and church occupy a full city block in the Belén neighborhood. A large fire in 1991 destroyed much of the church, including the oldest cloisters. The restoration effort quickly won broad popular community support. Today the social programs that have been implemented are extensive, and the facilities serve “families, children, young people, mentally and physically disabled persons, and the elderly... [through] recreation, relaxation and performance spaces, a home for the elderly (18 apartments for 50 people...) a school for special needs kids, museums, kitchens, a computer and internet lab, workshops for crafts, a small factory for the production of clothing, health and eye care clinics, and a pharmaceutical warehouse and dispensary” (Our Lady 2014).



Figure 3: The Belén Convent, originally built in the 1700s, was abandoned early in the 1900s and rehabilitated by the Office of the City Historian in order to serve many of the same functions it originally did, in addition to providing new social services. Source of image: Author 2014.

Despite being a restoration project executed by the Office of the City Historian, the social services now housed in the Belén Convent are independent of the Office. The staff at Belén conduct surveys to assess what additional needs are not being met and the programs grow and change with the community. Restoration by the Office of the City Historian is still ongoing, with additional funding from international sources. The convent was intended specifically to return to its original functions, so in this way the restoration was not only of the physical building, but also of the services as well.

The third project to be examined could be considered a restoration of skills in addition to restoration of buildings. The Office of the City Historian simultaneously achieves both social and preservation goals through La Escuela Taller or the Workshop School. At first glance, the Workshop School could appear to be wholly focused on preservation activities. The purpose of this school is to train young people in traditional preservation trades, many of which would not be taught outside of this type of program.



Figure 4: Escuela Taller students at work on a project in the Colón Cemetery. The trade skills these disadvantaged youth learn on projects such as these are valuable in the preservation profession. Source of image: (Author, 2014).

The program, though, is another social effort. The students, all between the ages of 18 and 25, are all disadvantaged in some way. For example, family conditions may have prevented them from finishing high school, for all of them the University was not an option (Rodríguez Sánchez "Interview" 2014). In Cuba there are no tuition fees, but students are required to pass tests in their field of study before they can attend college. Many of the Workshop School students live in Old Havana, while other Cuban cities have similar programs for their residents (Castillo 2013). These students learn trades like masonry, mural painting, ironwork, glasswork and other trades critical to restoration work. The chance to study at the school is so popular that they are only able to accept between 10 and 20% of those who apply. After graduating from the two-year program, students work for the Office of the City Historian, private companies, in other countries as preservationists and or in non-preservation fields where their technical skills are still in high demand (Rodríguez Sánchez "Interview" 2014). By opening the door to economic opportunity to residents of the communities where the work is happening, the Office of the City Historian builds support for all their projects, not just for the Workshop School projects. While increasing the value that the community places in preservation, they are also building a strong workforce so that preservation projects can be accomplished. It would be difficult to separate the two priorities in this example; it is an effective blending of meeting two needs: preservation and job training with one program: the Workshop School.

The Office of the City Historian addresses goals at multiple scales: through individual buildings, city blocks, neighborhoods, and the district of Old Havana. Each of these projects also addresses an additional, similarly scaled social issue. For example, the construction work being done to upgrade the infrastructural systems of Old Havana will benefit the residents and businesses there, but the work is also taking into consideration the growth of the tourism sector. Since most of the buildings were constructed before the advent of electricity, the electrical system is not systematic or reliable in many buildings with wires running in every direction in order to be able to service all the different residential units. After being in Old Havana for just a short time you will see water delivery trucks supplying potable water each day to many locations around the historic center. There is nothing to suggest that demand will drop in the near future. While the torn up streets are inconvenient for pedestrians and bicycle taxi drivers, the improvements that will come to both the residents and the tourism sector will be greatly appreciated.

5.0 BENEVOLENT DICTATOR?

Through the collection of examples it is possible to begin to tease out the circular relationship between preservation, social projects and economics. It is difficult to analyze the connection between built heritage and a living breathing community because much of daily life is the same whether or not the setting is historic. For example people in every city cook meals, buy goods and go to work. The intangible history as represented by the tangible architecture colors the community and gives it a sense of place, of rootedness. In turn, the architecture without the people becomes a museum, static and unchanging. When a community like the one in Old Havana has so many needs: physical repairs, overcrowding, healthcare for the elderly, it seems frivolous to dwell on the value intangible history. It seems far more important to address the needs of daily life. By creating economic dependencies between preservation and social services, the Office of the City Historian has created a network that would not function without any one of the pieces. Despite the positive accomplishments that the Office of the City Historian has made, there are still questions that have to be addressed. In general, the image that the Office would like to present is that the "human being is the protagonist of the process" (Castillo 2013). In speaking with residents of Old Havana and other neighborhoods of Havana, this may be called into question. Joseph Scarpaci in particular, questions the number of residences that really are retained after restoration. Old Havana is extremely overcrowded, "planners insist that only half of the roughly eighty-five thousand residents occupying Habana Vieja should reside there" but some formerly residential buildings have been converted into business spaces (Scarpaci 2005). As a result of the extreme overcrowding, people have to be moved to other neighborhoods. Many received new apartments in the public works housing in Havana del Este. While some residents are extremely happy to have moved their large extended family from one small, inadequate apartment perhaps into two newly built apartments, others feel that the projects are unattractive, have bad services and bad public transportation (Scarpaci 2005). Resolving all of the competing demands on the current urban fabric in such a way that appeases all parties may not be possible. Still it is very difficult to justify expenditures on hotels and restaurants to a resident with a damaged leaky roof; the value of tourism investments does not stop the rain from falling in one kitchen (Scarpaci 2005).

In some respects it seems that the Office of the City Historian behaves like a benevolent and responsible dictator. The projects and services that they offer are valuable and address the needs of the community, but there is not a formal system to consult the population themselves as to their needs. From an outside perspective, the projects that the Office of the City Historian has enacted seem powerful and pertinent. In

order to effectively manage the Integral Development System, very well organized leadership is required. The Office of the City Historian has created dependencies between tourism, social needs and preservation requirements. The relationships between these elements are not obvious or simple, but they have resulted in important accomplishments in all three realms. In order to see the big picture, the singular body of the Office of the City Historian is better positioned than the population at large. As Havana and Cuba reestablish relations United States, whether or not the Office of the City Historian will be able to maintain the potentially delicate balance between preservation, social projects and economics may depend on the strict control that they have benefited from to date.

REFERENCES

- Alfredo. 2014. Interview with Alfredo, cab driver. Notes.
- Babb, Florence E. 2011. *Che, Chevys, and Hemingway's Daiquiris: Cuban Tourism in a Time of Globalisation*. *Bulletin of Latin American Research* 30 (1): 50–63.
- Castillo García, Maysel, and Marién Ríos Díaz. 2013. *La Habana Vieja, Un Presente Audaz: Old Habana, a Fearless Present*. In Congreso Iberoamericano, 37–56. San José de Costa Rica.
- Cuban Peso. 2014. OANDA. Accessed November 18. <http://www.oanda.com/currency/iso-currency-codes/CUP>
- Diener, Roger, Marcel Meili, Christian Schmid, Milica Topalovic, Christina Holona, Christian Muller Inderbitzin, Hana Disch, and Thies Brunken. 2007. *Public Housing in Havana: History of Ideas*. Sommersmester 2007. ETH Studio Basel.
- González, Gilberto. 2010. *Hogar Materno Infantil de La Habana Vieja, 13 Años de Servicio Exitoso*. August 16. <http://bloguerosrevolucion.ning.com/profiles/blogs/hogar-materno-infantil-de-la>
- Gott, Richard. 2004. *Cuba: A New History*. New Haven: Yale University Press.
- Habaguanex. 2015. *Hotel Beltrán de Santa Cruz*. Accessed February 5. <http://www.habaguanexhotels.com/en/hotels/hotelbeltrandesantacruz.asp>.
- "Oficina Del Historiador de La Habana." 2014. Accessed November 16. <http://www.ohch.cu/oficina-del-historiador/>
- "Our Lady of Belén Convent and Church." 2014. *Convento Y Iglesia de Nuestra Señora de Belén*. Accessed January 22. <http://www.cubapeace.ca/belen.php>.
- Red de Oficinas del Historiador y del Conservador de Las Ciudades Patrimoniales de Cuba, and Oficina del Historiador de la Ciudad de La Habana. 2012. *Luces y simientes: territorio y gestión en cinco centros históricos cubanos*. Cuba: Ediciones Boloña.
- Rodríguez Cunill, Oscar Jaime. 2014. Interview with Jaime Rodríguez. Recording.
- Rodríguez Sánchez, Pedro. 2014. *Interview with Pedro Rodríguez Sánchez*. Recording.
- Rodríguez Sánchez, Pedro. 2014. *Strength Training for Specialized Work: Restoration of Old Havana*. PowerPoint and lecture recording, The University of North Carolina at Charlotte, August 25.
- Scarpaci, Joseph L. 2005. *Plazas and Barrios: Heritage Tourism and Globalization in the Latin American Centro Histórico*. 1st. ed. Society, Environment, and Place. Tucson: University of Arizona Press.
- Symmes, Patrick. *Thirty Days as a Cuban: Pinching Pesos and Dropping Pounds in Havana*. *Harper's Magazine*.
- Una Experiencia Singular: valoraciones sobre el modelo de gestión integral de La Habana Vieja, Patrimonio de la Humanidad*. 2006. UNESCO. <http://www.planmaestro.ohc.cu/recursos/papel/libros/singular.pdf>.
- Vladimir. 2014. *Interview with Vladimir, Cubatur tour guide*. Recording.

Evaluative place-making of the arts and craft movement: A sustainability framework

Jeanette Burman¹, Brian R. Sinclair²

¹University of Calgary | Haskayne School of Business (MIS), Calgary, Alberta, Canada

²University of Calgary + sinclairstudio inc., Calgary, Alberta, Canada

ABSTRACT: Present day and mass architectural practices do not always account for the finer points of place-making; in fact there is a pressing need to re-evaluate trends of modernity to sustain the practice itself. To consider our future in a more creative manner, the researchers argue that viable, holistic and sustainable systems approaches to professional architecture must consider environmental, social, and economic conditions in connection with buildings and the people who occupy them.

Although history can bind us in terms of tradition, it can also provide guidance towards a sustainable future. Due to its inherently idealistic and humanistic approach, the founding principles of The Arts and Craft Movement (1850 – 1920, active until 1940s) inspired a flexible framework and systems approach to building and design for today's economies. As architectural research looks to the future, it needs also to look to past resistances of architecture using integrated approaches to overcome holistic challenges. The disciplines of architecture, design and planning can utilize Nature, Vernacular, Craft, and Materials; for dwellings equipped to meet both the long-term needs of localized occupants and the urgency to pursue global sustainability.

The present paper outlines these four tenants of the Arts and Craft Movement as a novel sustainability framework using the work of Kenneth Frampton as a catalyst for needed change in modern and post-modern architecture. It was Frampton who, during the sterile industrial periods of modernity that he heavily criticized, looked back in history to Morris and Webbs' Red House as a starting point for resolution and resistance. Whether Red House, Morris' wallpaper, Mackintosh's Library, the Greene Brothers' bungalows or Frank Lloyd Wright's Fallingwater, such hallmarks of the Movement have borrowed heavily from the past and across cultures. Herein lies a paradox: How do we maintain place-making and honor history in a local and sustainable context while by default being part of an emerging pervasive global community? A holistic assessment of the Movement's guiding principles reveal elements of Integrity, Physicality, Dignity, and Functionality—transforming perceptions of its historic ideologies into a movement arguably ahead of its time.

Design today confronts intense challenges due to the complexity of problems and the common approach of narrowed disciplinary focus. In contrast to such constricted viewpoints, the current research aims to deploy systems thinking and more holistic methods in order to better resolve design. Through the critical examination of the Arts and Crafts Movement, and a reconsideration of aspects of Nature, Vernacular, Craft, and Materials, the authors propose a framework for sustainability. Core elements of said framework, namely Integrity, Physicality, Dignity, and Functionality, afford designers an innovative means of analyzing problems with an aim to achieve more meaningful spaces, more potent places, and a more sustainable environment.

KEYWORDS: Architectural History, Place-Making, Sustainability, Systems Thinking, Conceptual Framework

INTRODUCTION

Holism: (from ὅλος holos, a Greek word meaning all, whole, entire, total) a theory that the universe and especially living nature is correctly seen in terms of interacting wholes (as of living organisms) that are more than the mere sum of elementary particles (Merriam-Webster)

A building occupying, so to speak, four dimensions of space – the name of the fourth being Time - which had sailed across the centuries its vessel, which from bay after bay, chapel after chapel, seemed to conquer and stretch across not merely a few yards of soil, but each successive epoch from which the whole building had emerged triumphant (Swann's Way, Marcel Proust)

In sustainable systems thinking, how design works or doesn't work is influenced by internalities and externalities—the inclusion and exclusion of pre-determined factors impacting each other through delivery. Sustainability in architecture is the result of these design influences producing the least negative impact on each other through the most integrated approach—determining the extent to which a building will work for and with its users, economies, environment, etc. Conceptual frameworks present mechanisms, or vehicles, with which complexity can be better grasped and managed in our pursuit of sustainability. For example one of the authors, in his Holistic Framework for Design + Planning, underscores the vital need to evoke systems thinking, integration (e.g. Agility, Fitness, Diversity, Delight) and interdisciplinarity to address such complexity, to challenge endemic fragmentation, and to confront separation/isolation that defines an increasing number of contemporary crises (Birch and Sinclair 2009). Architecture today, in light of sustainability, ushers in both obstacles and opportunities—where the physical and social construct of place-making is a crucial human element. In the essay "Towards a Critical Regionalism: Six Points for an

Architecture of Resistance”, Kenneth Frampton develops his own theoretical framework while explaining that universal modern and post-modern architecture of that time neglects to address essential aspects of the human and social condition resulting in “*placelessness*” (Frampton 1983, 25). He also identifies several principals that coincide with this research and support the notion of Arts and Craft architecture as a resistance to neglectful design. We also suggest that by doing so, Frampton implicates Arts and Craft principles as pre-cursors to the sustainability movement for a new era of concerns. Frampton laid the groundwork for addressing ahistorical, allochthonous and unsustainable universal practices in modern architecture movements such as the International Style as well as postmodern architecture—instead championing historical reverence, human significance, and connection to nature and indicating the Arts and Craft Movement and Red House (1859) as an impetus for resistance to “utilitarianism and the division of labour of modernization” (Frampton 1983, 18). However, while addressing the need for altering neglectful trends of progress in architecture, Frampton (1983) also stresses not trying to reenact nostalgic architecture of the past, calling for a delicate balance of ideals and reality. Furthermore, Frampton identifies the framework of the Arts and Craft Movement to include:

“Structural integrity, a desire to integrate buildings into their site and into the local culture, practical design, sensitive site layout, the use of local materials, as well as a profound respect for traditional building methods.” (Frampton 1992, 43)

Currently, there is substantial literature on the history of the Arts and Craft Movement identifying the main tenants without intrinsically linking them to sustainability today or considering systems operations (Cumming, E., and Kaplan, W. 1991; Buchanan, W. 2004; Davey, P. 1980; Falet, D. 2007; Makinson, R. L. 1984; Stansky, P. 1985; Wright, F. L. 2005). There is support regarding interdependency and flexibility of green building systems guidelines such as LEED credits and the development of new models for improved communicative networks in the pre-design phase using agent-base modeling and the eco-charrette process (Said, H et al. 2014; Kibert 2013). Yet, these types of guidelines developed to provide sequential sustainability approaches do not address holistic implications of place-making and even ignore major components of sustainable systems operations. Existing green building construction systems guidelines, such as LEED and BREEAM (Kibert 2013), do not identify holistic systems implications of building and overall have not proved effective in embedding meaning in otherwise anonymous spaces. While considering place-making in their writing, Bennetts, H. et. al. (2003) have identified the systems and subsystems of sustainability—environmental, social, economic, occupants, and buildings; we add the key Arts and Craft principles and synthetic guidelines as the basis of systems operations to facilitate our discussion. There are also effective approaches to key and foundational sustainability systems (Bennetts et al. 2003; Bokalders, V., and Block, M. 2010; Obata et. al. 2004; Pye, D. 1986; Rappaport, A. 1990; Sassi, P. 2006; Stea, D., and Mete, T. 1990). However, these qualifications do not approach the topic of holistic and interoperable systems sustainability in the place-making arena or consider the historical implications of the Arts and Craft Movement. In fact, little has been written on the Arts and Craft Movement as a holistic approach to sustainability in systems, place-making or art historic literature making the value of this research both novel and a contribution to multiple professional and academic disciplines.

The rise, magnification, and transformation of modern building practices in the profession of architecture have had an undeniable impact on sustainability. Although the profession has reconciled many of its concerns with modernist ideals to shape more sustainable spaces, there is still a need in architecture for guiding sustainable systems approaches whereby environmental, social, and economic conditions are considered in holistic relation to occupants, spaces, and places (Bennetts et al. 2003). Conceptual sustainable design is approached by ensuring these principles—occupants, environments, social structures, and economies—exist in cooperative and integrated systems—whereby interoperability determines the extent of sustainability and place-making is rendered possible. However, implementation requires that these concepts, systems, and subsystems effectively communicate with each other in relatively seamless modes. The alliance of nature and culture within the Arts and Craft Movement provides an effective model for re-evaluating architectural practices in multiple phases as well as critical issues of sustainability facing the profession today—whereby the foundational principles can be re-contextualized to provoke thought and holistic considerations in design and potentially used in pre-existing models. The four foundational principles of the Arts and Craft Movement are widely represented in both the theory and structures of architects such as Charles and Henry Greene, Frank Lloyd Wright, and Charles Rennie Mackintosh: Nature, Vernacular, Craft, and Truth to Materials. We propose that these principles act as a counterbalance to otherwise neglectful design and as a communicative network to foundational sustainability systems and subsystems. In Figure 1 we present a modification of Bennetts et. al. (2003) systems and subsystems view by integrating the four foundational Arts and Craft Movement principles as interacting systems with imperative ‘subsystem’ synthetic place-making guidelines—Physicality, Integrity, Functionality, and Dignity. Our revised systems approach begins to delineate technique-orientated operations and functional interoperability with holistic implications in space and time. This research employs a re-contextualized view of the buildings and ideals of

and design, but rather to provoke thought, discussion, and consideration to the complexity of issues at play in sustainable design, while providing an explicit but not definitive approach to place-making. The synthetic framework presented within the present paper aligns with the aforementioned synthetic elements and the four tenants of the Arts and Craft Movement as a holistic process inclusive of autochthonous building and evaluative place-making—identifying and further delineating requisite sustainable systems and key interoperability principles for a sustainable future in architecture.

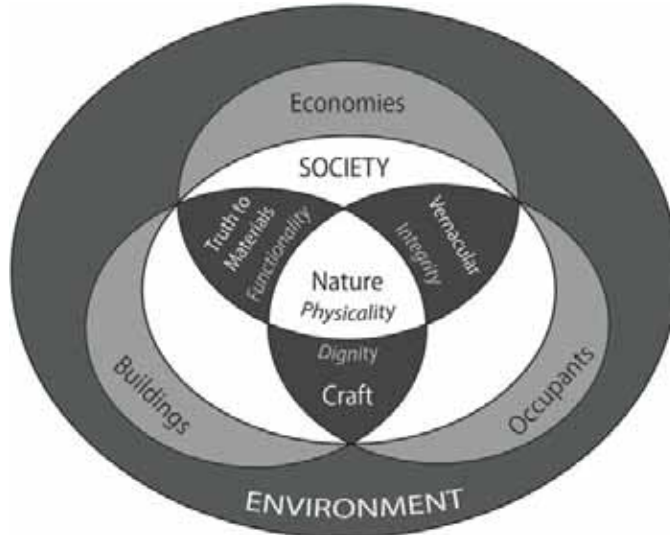

Figure 1: Arts and craft movement principles systems integration adapted from systems and subsystems view (Source: Bennetts, Radford, and Williamson 2003, 85).

1.0 REVERENCE FOR NATURE

Synthetic Guideline: Influenced by physicality, the ability to integrate into and be influenced by the natural environment, natural ecosystems, and Eco-ethnography.

Issues of environmental degradation due to industry’s actions in the world today are not entirely different from those faced by the founding father of the Arts and Craft Movement, William Morris, and his companions. As response and resistance, nature plays a central role in the design and influence of the Movements’ and Morris’ work—not only in Morris’ legacy of patterns and designs as seen in the textile Wandle but also in his writings and purposeful respect for the natural environment; especially the Thames River—of which he saw its horrendous exploitation during the industrial revolution (Falet 2007). Further examples of reverence for nature are found throughout the Movement—we look at how these examples of historical architecture holistically interact with and impact their environments as well as how accounting for physicality in design can create place.

1.1. Physicality: integration, influence, engagement

Today, the ecological integration of settlements and infrastructure into natural surroundings act as a guide to inform design, planning, and building in sustainable architecture (Bokalders and Block 2010). Although the current use of green building rating systems may account for protecting natural habitat (Kibert 2013), there is neglect of the significance of physicality in design. The integration of architecture and nature is found in the Arts and Craft Movement as far back as Stoneywell Cottage’s (1899) earthen wall and as a concept deeply entrenched in the founding principles of some of its most memorable architects. For example, Charles and Henry Greene practiced natural integration as the first two major conditions of their own strategy, believing the style of a house should be determined by four conditions: “climate, environment, materials available, and habits and tastes – i.e. life of the owner” (Makinson 1984, 161). These concepts were executed by the Greene brothers in their hundreds of structures, both in interior and exterior settings, and are dramatically emphasized by Charles Green in D.L. James house (1918) whereby the landscape receives and extends out of the structure’s form; the building acts as the peak of a cliff towering over the crashing Carmel, California waves below, and the building, with stone masonry growing out of the rock itself, utilizes the view from both public and private spaces (Makinson 1977). Frampton addresses how negating the natural environment by, for example, leveling the naturally hilly or robust topography of a building site so that it is flat results in “placelessness” and that geographical place with its topographical, climatic, vegetative, and lighting variables should be considered significant in a building’s inception and creation (Frampton 1983, 26). In this way and as seen in the Greene’s design, the natural site can be used to inform the design:

“terracing of the same site to receive the stepped form of a building is an engagement in the act of cultivating the site.” (Frampton 1983, 26)

Taliesin West, as seen in Figure 2, is another example of the interplay of material and nature such as the canvassed ceiling in the drawing room where natural light filters into the room through the material—Frampton describes this type of interaction of nature and culture as the “place-conscious-poetic” (Frampton 27). Frank Lloyd Wright’s Fallingwater hyperbolizes the flow of water into its design by transforming the meditative setting of a waterfall into its structural landscape, effectively allowing for the structure and nature to communicate. Both serve as examples of physicality operating within the sustainability subsystem of human economies and ultimately the holistic goal of place-making. Sinclair (2013) reiterates this displayed notion of physicality in the spiritual realm by describing the significance of engaging occupants in connection to natural forms—in the context of biophilia and biomimicry. In this view, sustainability in place-making is dependent on the human experience and relationship between occupying space and the physicality of nature. Charles Greene’s interest in spiritual spaces and use of Eastern forms exemplify both literal representations of nature and more subversive integrations: the horizontality of a structure’s view meeting the skyline or a widened porch dissolving into a Japanese rock garden as seen in the William R. Thorsen house (1908-1910)—the enclosed and “cradling” placement of the house integrated on a sloping hill also acts as a sound barrier from traffic noise (Makinson 1977, 175). Additionally the traditional bungalow structure of which both the Greene’s and Wright were known, account for climate changes, allowing cooling from shading roofs and is a ‘borrowed’ form, to be discussed in the next paper section on ‘Vernacular’. Thus when physicality is neglected, space is unable to elevate to place. By only enhancing ecosystems and mitigating heat island effects, for example, current sustainability ratings systems that attempt to address nature are holistically inoperable with their interacting systems. By engaging the site, architecture can advocate interoperability to ultimately save costs to other parts of the system—both capital (e.g. heating and electricity systems) and non-capital (e.g. holistic economies and ecological sustainability). The landscape’s ability to influence, integrate, and engage the structure must be enabled for sustainability and place-making to be possible.

Through implementation of this framework, we can identify Frampton’s *place-conscious-poetic* and the first sustainability principle of the Arts and Craft Movement as allowing an interaction between the natural environment and culture, versus the limitations and harmful postulations of industrial and technological progress that can neglect holistic implications (Frampton 1983, 27). These two opposing positions can, at the most basic level, be a comparison of holistic functioning systems versus non-functioning systems, or rather interoperability versus exclusionary operability, and within the context of complete life-cycle costs, sustainable place versus potentially unsustainable space. Engaging the natural environment in relation to the built environment allows for the synthetic element of physicality to be addressed, the gateway for integrity and the next element of sustainability in Arts and Craft architecture: vernacular.



Figure 2: Taliesin West in Scottsdale Arizona by Frank Lloyd Wright. (photo: Brian R. Sinclair, 2014)

2.0 VERNACULAR

Synthetic Guideline: Influenced by integrity, the ability of the project to be serviceable and assess real costs to occupants—social, political, and spiritual economies.

In the place-making realm of vernacular, sustainability includes traditions of building, the economies of people, cultural identities, and wellbeing (Bennetts et al. 2003). The Arts and Craft Movement approaches vernacular in two distinct ways: firstly, as token and symbolic and technological reprieve from environmental degradation as discussed in physicality—the iconographic medieval country church serving as the ideal model and refuge from the industrial cityscape (Cumming and Kaplan 1991); secondly, in the practicality of living and building through the architectural virtue of use whereby the builder adapts the building to the

needs of the user—adding a window, a room, a buttress—based on need of use as opposed to symmetry of architectural design or commodified consumption (Davey 1980). Frampton's concept of *arrière-garde* parallels vernacular, acting as a resistance to the commodity and media-driven economies of modern building practices while celebrating traditional forms in universal "world culture" (Frampton 1983, 20). Current green building rating systems approach style through a schematic interpretation of innovation without the scope of inclusive sustainability and holistic ingenuity. We address the systems operational discourse of vernacular, embracing traditions in the Arts and Craft Movement and their service to holistic economies while establishing integrity in place-making.

2.1. Integrity: economies, serviceability, adaptability

The holistic sustainable systems approach to vernacular is horizontally integrated, inclusive of interacting subsystems and the synthetic element of integrity, allowing for interoperability and ultimately a more potent place for users. Vernacular building situates itself within holistic sustainable systems building by addressing environmental, economic and political, and social factors. Conceptual frameworks for vernacular architecture effectively identify the multiple economies and factors of building (Lawrence 1990), but do not identify the synthetic elements needed to deploy holistic sustainability and are therefore limited in functional implementation for place-making. The traditional building techniques of ancient Chinese and Japanese vernacular—with political, cultural, and spiritual identities, heavily influenced the Arts and Craft Movement. From design delivery of site layout to include the central spiritual retreat of Japanese gardens to the simplicity in use of materials, design, and structural integrity of mortise and tenon construction, intercultural influence is at the forefront of design (Cumming and Kaplan 1991). There is an immediate conflict raised in the infinite possibilities of universal technology approaches to building and design in an ever increasingly connected world, where tradition in technique and culture is often replaced with what are deemed systemic efficiencies but result in a loss of information. As Frampton (1992) addresses, the modern day paradox and conflict of retaining tradition in a global context is recognized as problematic by Paul Ricoeur when he states:

"But in order to take part in modern civilization, it is necessary at the same time to take part in scientific, technical, and political rationality, something which very often requires the pure and simple abandon of a whole cultural past. It is a fact: every culture cannot sustain and absorb the shock of modern civilization. There is the paradox: how to revive an old, dormant civilization and take part in universal civilization."
(Ricoeur, 1965, 277)

The intercultural building techniques used in the Arts and Craft movement were not regional to the architects who used them such as Frank Lloyd Wright and Charles and Henry Greene—and consequently their use addresses the Ricoeurian paradox: if modern civilization is universal regardless of culture, then tradition in building, design, and technology can be as well, embracing technology and design through tradition as opposed to refusing culture. The risk is appropriation or negligent amalgamation, meaning sustainable interoperability of systems and subsystems such as fundamental human economies must be addressed to avoid alienation or 'watering-down' of potent places. In contrast, Amos Rapoport describes the style trajectory of the built environment in a vertical continuum: "Primitive→Vernacular→Popular→High-Style" (Rapoport 1990, 79). This exclusionary vertical alignment does not allow for linkages between each style with any depth and results in excess of formation—the ratio of vernacular, primitive, and popular buildings vastly outweigh those designed by professional architects (Rapoport 1990). Thus the relevancy of vernacular building to the majority of users in a global context reiterates its significance as paramount to holistic sustainability and place-making for future and localized international development. It is through exclusionary integration that present-day architecture heavily risks circumventing vernacular and ignoring interconnected systems—resulting in *placelessness* (Frampton 1983, 25). The Arts and Craft Movement is also able to identify human elements and occupants in relation to use and impact of space and place. In considering vernacular as an integrated horizontal operational system with positive externalities, the Movement allows for inclusionary operating principles with natural competitors for implementation. For example, sympathy and interest in the life of the user was instrumental in the many designs of Charles Rennie Mackintosh. Mackintosh observed the occupants' behaviors, daily needs, and routines—determining and delivering integrity in design by thoughtfully considering use throughout the interior and exterior settings for different occupants based on their individual needs (Cumming and Kaplan 1991). These adjustments to design spillover holistic benefits to interconnected systems such as views and eco-integration. In a contemporary light, computer modeling can systematically replicate the famous Glasgow School of Art library, Mackintosh's most well known creation recently destroyed by fire, but will it be elevated to place in this time? The role of the creator in the following paper section 'Craft' will attempt to resolve part of this issue, but the holistic implications of integrity through use suggest the need for further analysis. To assist, a more robust analysis of holistic economies can describe the direct act of user participation as the "*use value*" of the building, where "non-reciprocity in the place-making arena" is representative of crisis in building and seen most often in the modern socio-economic strata (Stea and Turan 1990, 113). Furthermore, by removing the participation of the occupant in the process of building through sales or "*exchange value*" in a modern political economy, the goal of place-making is circumvented (Stea and Turan 1990, 113). Thus, modern firm integration and policy development becomes necessary for implementation—and a whole work of art to be discussed in 'Craft'. The importance of the builder and occupant are intricately linked to sustainability in vernacular building and in terms of the synthetic indicator: integrity. It is only logical that the joy, skill, wisdom, and visual integrity of craft also play a significant role in developing sustainability in the

place-making realm—these human elements are indicative of a Whole Work of Art and the next synthetic place-making guideline: dignity.

3.0 CRAFT

Synthetic Guideline: Influenced by dignity, projects must be pursued with skilled and localized labour. The durability, aesthetic, and maintenance of the project are intertwined with the joy of building and using.

The idea of “correct building” is a fundamental aspect of healthy and sustainable buildings as well as longevity and practicality (Bokalders and Block 2010, 171). William Morris describes craft by hand as the key element to a Whole Work of Art and the happiness of those who build and those who dwell, indicating the spiritual economy of building inclusive of delight or joy (Stansky 1985). As discussed in the vernacular arena, the structural functions of mortise and tenon building as well as the tectonic form indicate universality within the movement and a resistance of the machine-driven skeletal framework of modern buildings (Cumming and Kaplan 1991). The rigidity of mass-produced output has tended to be less reflective of holistic and interoperable frameworks than output that allows for human input and dialogue. That said; emerging deployment of mass customization through digital tools has potential to shift this scenario bringing, for example, richer human dimensions to prefabrication, modularity, and industrialized building. We address the concept of a Whole Work of Art in relation to interoperable sustainability principles and best practices while considering the dignity of spaces in place-making.

3.1. Dignity: joy, durability, aesthetic

As a reaction to skilled workers being replaced by machines that produced inferior industrial outputs, craft is the pinnacle of retribution in the Arts and Craft Movement; it also serves as a significant representation of the human element within the sustainability framework. The quality of “workmanship of risk”—hand designed and created production—in regards to durability and quantity of consumption is such that mass production of modern technology requires mass single item plants and product; and that due to the individuality of human wants and needs, the quantity of these mass single item plants continually increases while the objects created are inferior and holistically neglectful forms (Pye 1986, 7). Hand designed and created production acts as resistance to an over-dependency on light industries, where made-to-order is, more often than not, not an option. However, our framework is not solely interested in handmade construction but rather the significance of human input in constructing and crafting design as well as the consideration of place-making versus technological processes that can limit spaces. The role of mass production, to date arguably characterized by repetition and the risk of banality, is by principle in dispute with holistic thinking—prefabrication versus instilling place-making through handmade or made-to-order production is a dichotomy unto itself.

In support of simplicity, and in part reaction to the excesses of Victorian opulence, artists and architects of the Arts and Craft Movement, such as Charles Rennie Mackintosh and Margaret Mackintosh, created simple, undecorated, and purely geometric designs that most certainly influenced the modern aesthetic, combined with mythical imagery to engage connecting subsystems, were unique as inputs for their time. The Mackintosh’s approach to create an art of its time as opposed to re-creating forms of the past is symbolic of their ingenuity but also represents localized sustainability (Cumming and Kaplan 1991). Their buildings pioneered form and functionality with craft input while balancing yang-focused geometric forms with yin-focused organic designs. Most famously, the Glasgow School of Art is a distinctive unity of craft with simplicity in design—a complete work of art where subsystems are integrated within the tectonic form to service the entire operating system (Buchanan 2004). Specifically, and as previously discussed, Mackintosh’s design of the library most recently destroyed by fire integrates the construction of each of its intricate parts with Mackintosh’s emotive economy as well as with the overall mood and cadence for knowledge of the room (Buchanan 2004). Thus the joy of building is translated into the economy of use. Furthermore, when addressing the economy of scale of handcrafted designs of the Arts and Craft Movement, the scale informs the aesthetic—rhythmic and organic forms that are reflective and operable with the subsystem of reverence for nature, whereas industrial machine-driven designs create duplicated standardized outputs disconnected from the larger system (Cumming and Kaplan 1991). The tectonic form was used throughout the Arts and Craft Movement not only as a means to approach vernacular but also as the most structurally sound and versatile in hand-based building (Cumming and Kaplan 1991). Frampton’s reverence for the tectonic form emphasizes hand crafted inputs and systems thinking:

“The Tectonic remains to us today as a potential means for distilling play between material, craftwork and gravity, so as to yield a component which is in fact a condensation of the entire structure. We may speak here of the presentation of a structural poetic rather than the re-presentation of a façade” (Frampton 1983, 28).

The sustainability benefits of craft in both regional and global economies vastly outweigh the convenience and so-called efficiencies of industrial reproduction. Firstly, by providing localized skilled employment along the supply chain and direct labour. Secondly, with recognition of marginalization issues, by decreasing variability of longevity costs—the ownership of output is centralized locally, thus the accessibility and durability of the structure is interdependent with the success of localized economies. Consequently, a vision

carried through to fruition significantly identifies architects of the Arts and Crafts Movement as ‘different’ than current firm standards of fragmented facilitation for both the user and builder. However, vision does not exclude collaboration or facilitation whereby modes of firm integration are imperative to place-making. This research acknowledges the significance of sterility of modern firm structure in terms of craft and will address the potential for further research in this area in our conclusion. In the dignity of craft lies the synthetic place-making guideline of functionality, wherein materials are the central input.

4.0 TRUTH TO MATERIALS

Synthetic Guideline: Influenced by functionality, materials should be local, renewable and long-lasting; requiring little alteration of form or transformation; the healthy engagement of senses and ability to adapt for changing needs in reasonable cost cycles.

The sustainability of materials used in building can be measured using a Life Cycle Analysis (LCA)—taking into account extraction, transportation, installation, use, and re-use/disposal (Bokalders and Block 2010). Although current green building rating systems do take material processes and LCA into account, via product ratings, material loops, and locality, they admittedly face challenges in accurate and verifiable data across universal supply chains as well as production and resource viability (Kibert 2013). Additionally, the current standards do not recognize the significance of holistic functionality in space and invariably lack constructive modes of resistant material building resulting in disposable spaces and holistically harmful processes. The Arts and Craft ideology of material awareness, locality, and natural harmony invariably decreases the life cycle costs (LCC) of a structure and has a decreasing environmental impact in the sustainability system while strengthening social and economic integrity (Cumming and Kaplan 1991). We further explore how maintaining material integrity is necessary for interoperability in sustainable systems and functionality in place-making.

4.1. Functionality: availability, tactility, maintenance

Truth to materials and resulting forms in the Arts and Craft movement—stones, wood, ceramics, and glass—are grounded in production processes with interdependent systems. Morris’ fundamental belief that good design can only be accomplished through knowing production and in turn knowing materials was the true impetus for resistance of environmentally and socially harmful industrial processes which drove the Arts and Craft Movement (Cresswell et al. 2003). Material production is holistically operable with nature, vernacular style, and craft; therefore sustainable material selection and lifecycle is dependent on this interoperability. The unadorned and ‘organic’ use of material in the Movement relies on the interconnected systems for true functionality to be achieved. For example, the use of timber frame building in the Arts and Craft Movement was popular for both aesthetic and economic reasons. The indigenous oak used in furniture, framing, and interior elements was mostly driven by economic necessity—when considering the scarcity of walnut or imported woods, oak became the most sustainable choice (Cumming and Kaplan 1991). By sourcing locally resilient and renewable materials in a sustainable manner and then limiting the transformation of the material itself there is a reduction in the energy required to produce the useable product, yet additionally in maximizing the use of locally sourced, natural, and renewable resources, other elements of health and aesthetic are also included in design (Sassi 2006). This process immediately and unavoidably introduces an element of scarcity; therefore durability in construction through craft is integral to LCC, increasing the longevity of the built environment and its constituent components. When considering the sustainability of materials, resiliency of cost cycles and local availability needs to be considered as similar to use value vs. exchange value (Stea and Turan 1990, 113). Take the current and historic use of corrugated metal siding in California as an example: although this material is not necessarily local in terms of resources, it has been used as an unaltered material for many years in the region for sustainable construction and is considered indigenous (Greene 2009). By being intrinsically linked to production processes, the ability to maintain these built environments also increases based on availability and interdependency versus the potential holistic challenges (i.e. wages, human economies, and environmental degradation) in light-industry-based replication from non-regional and potentially unstable sources. Instilling functionality via availability and maintenance assists in transforming spaces into meaningful places.

These natural materials are appealing for more than just economic and environmental considerations. In Taliesin West, Frank Lloyd Wright uses cased but unaltered stones as the primary structural wall, bare canvass skylights (as discussed) and integrated carved wood beams as structural support. Wright states that bare, unornamented, and truthful materials have “*organic plasticity*”—a term he correlates with holistic use value as well as whole systems thinking:

“Integration of even the very word “organic” means that nothing is of value except as it is naturally related to the whole in the direction of some living purpose, a true part of entity” (Wright 2005, 148).

In the holistic system, tactile environment acts as a resistor to universal technologies by allowing the body to read an environment through the materials used in senses of smell, sight, sound, and touch -- versus materials that lack the innate connectivity required for holistic sensation (Frampton 1983). When the human experience of space is given greater dimensions with holistically communicative designs, place-making is approached through tactility of functionality. The tactile environment presents functionality with limited

modeling and costing integration with current green building systems guidelines and processes. This research calls for deeper commitment to holism, integration, and interdisciplinarity, creating further opportunities for continued research into the role of traditional and present day technology in the Arts and Craft Movement and sustainable systems architecture—using the described framework to facilitate discussion. With rapidly emerging technologies, including rapid prototyping, building information modeling, and computer numerically controlled fabrication means should be explored to better couple human needs with machined output. Our propositions around renewal, reconsideration, and engagement of the Arts and Crafts Movement unites the originators of the approach with Corbusier's Age of the Machine and Kurokawa's Age of Life. The sustainability of the future is in many respects propelled by embracing the past as the past embraced itself—creating, delineating, and utilizing the art of building in one's own time & place.

REFERENCES

- Bennetts, H., Radford, A., and Williamson, T. 2003. *Understanding Sustainable Architecture*. London: Spon Press.
- Birch, R. and Sinclair, B. "Spirituality in Place: Building Connections Between Architecture, Design, and Spiritual Experience," as provided to ARST 423 "Sustainability in the Built Environment", University of Calgary, Canada, Fall 2013.
- Bokalders, V., and Block, M. 2010. *The Whole Building Handbook: How to Design Healthy, Efficient and Sustainable Buildings*. London: Earthscan.
- Buchanan, W. 2004. *Mackintosh's Masterwork: The Glasgow School of Art*. Great Britain: Glasgow School of Art Press.
- Churchman, C. West. 1979. *The Systems Approach and Its Enemies*. New York: Basic Books.
- Cresswell, L., Lambert, B., and Goodier, A. 2003. *Product Design: Resistant Materials Technology, 2nd ed.* Oxford: Harcourt Education
- Cumming, E., and Kaplan, W. 1991. *The Arts and Craft Movement*. London: Thames and Hudson Ltd.
- Davey, P. 1980. *Architecture of the Arts and Craft Movement*. London: The Architectural Press Ltd.
- Falet, D. 2007. "The River at the Heart of Morris's Ecological Thought." in *Writing on the Image: Reading William Morris*, edited by David Latham, 73-84. Toronto: University of Toronto Press.
- Frampton, K. 1992. *Modern Architecture: A Critical History, 3rd ed.* London: Thames and Hudson Ltd.
- _____. 1983. "Towards a Critical Regionalism: Six Points for an Architecture of Resistance." In *The Anti-Aesthetic-Essays on Postmodern Culture*, edited by Hal Foster, 16-30. Seattle: Bay Press.
- Greene, D. A. "Diamond in the Rough (and Ready)." In *Dwell*, October 2009, 51-56.
- Kibert, C. J. 2013. *Sustainable Construction: Green Building Design and Delivery, 3rd ed.* Hoboken: John Wiley & Sons, Inc.
- Lawrence, R. J. 1990. "Learning from colonial houses and lifestyles." In *Vernacular Architecture: Paradigms of Environmental Response. Vol. 4 Ethnoscapes: Current Challenges in the Environmental Social Sciences*, edited by Mete Turan, series edited by David Canter and David Stea, 219-257. Aldershot: Avebury.
- Makinson, R. L. 1977. *Greene and Greene: Architecture as Fine Art*. Salt Lake City: Peregrine Smith, Inc.
- _____. 1984. *Greene and Greene: Architecture as Fine Art, 2nd ed.* Salt Lake City: Gibbs M. Smith.
- Obata, Y., Kanayama, K., and Furuta, Y. 2004. "Research on woods as sustainable industrial resources – evaluation of tactile warmth for woods and other materials." In *Sustainable Development of Energy, Water and Environment Systems, Volume 1*, edited by Afgan, N.H., Bogdan, Z., and Duic, N. 79-87. Lisse: Swets & Zeitlinger B.V.
- Proust, M. 2013. *Swann's Way: In Search of Lost Time Volume 1—The C.K. Scott Moncrieff Translation*, edited and annotated by William C. Carter. Yale University: Yale University Press.
- Pye, D. 1986. *The Nature and Art of Workmanship*. Cambridge: Cambridge University Press.
- Rapoport, Amos. 1990. "Defining Vernacular Design." In *Vernacular Architecture: Paradigms of Environmental Response. Vol. 4 Ethnoscapes: Current Challenges in the Environmental Social Sciences*, edited by Mete Turan, series edited by David Canter and David Stea, 67-101. Aldershot: Avebury.
- Ricoeur, Paul. 1965. "Universal Civilization and National Cultures," In *History and Truth*. Evanston: Northwestern University Press.
- Sassi, Paola. 2006. *Strategies for Sustainable Architecture* Abingdon: Taylor and Francis.
- Sinclair, B. R. 2009. Culture, Context and the Pursuit of Sustainability: Contemplating Problems, Parameters and Possibilities in an Increasingly Complex World. *Planning for Higher Education: The Journal of the Society for College and University Planning*. 38 (1).
- Said, H., Kandil, A., Nookala, S., Cai, H., El-Gafy, M., Senouci, A., and Al-Derham, H. (2013). "Modeling of the Sustainability Goal and Objective Setting Process in the Predesign Phase of Green Institutional Building Projects." *Journal of Architectural Engineering*, 20(2) June 2014.
- Stea, D., and Mete, T. 1990. "A Statement on Placemaking." In *Vernacular Architecture: Paradigms of Environmental Response. Vol. 4 Ethnoscapes: Current Challenges in the Environmental Social Sciences*, edited by Mete Turan, series edited by David Canter and David Stea, 102-121. Aldershot: Avebury.
- Stansky, P. 1985. *Redesigning the World: William Morris, the 1880s, and the Arts and Crafts*. New Jersey: Princeton University Press.
- Wright, F. L. 2005. *Frank Lloyd Wright: An Autobiography*. Warwickshire: Pomagranate Communications Ltd.

Representation and installation: Curating architectural exhibitions

Vikkie Chen¹

¹University of Waterloo School of Architecture, Cambridge, Ontario

ABSTRACT: In the past decade, there has been a dramatic increase in the number and profile of exhibitions about architecture that has rendered curating architecture a distinct field in the profession. In the current practice, architectural curation has become a creative process of representing and displaying architecture with the specific aim of generating an encounter for the viewer – whether professionals or members of the general public. New trajectories of curation extend the traditional presentation of architectural simulacra, to include development artifacts of architectural design, process based installations and full scale constructions, allowing exhibitions to explore ideas and issues that are otherwise difficult to express and examine. The multidisciplinary facets of contemporary architecture – with its complex relationship to culture, politics and other fields such as art, history and engineering – can now be investigated and discussed in a more generative fashion and the latent layers revealed and activated.

Unlike the artist, the architect does not treat the exhibition as just an end product; rather it is a tool for disseminating designs to the public, discussing issues among disciplines and experimenting with ideas. This paper reviews two projects that seek to establish new ways of connecting architecture to the public consciousness through curation by identifying and assessing the practices, techniques and challenges of curating and creating the premise for architectural exhibitions. Also, through these projects, the paper explores the potential of exhibitions as places of mediation, interaction, education, conversation, deliberation, inspiration and experimentation, as well as an act to enrich the cultural intensity of a community. Overall, this paper endeavours to give an expansive view on the theory and practice of curating contemporary architectural exhibitions, as well as expose the prospective ability exhibitions have for communication and development of architectural research in the cultural community.

KEYWORDS: Architectural Research, Curating, Exhibitions, Installations, Dissemination

INTRODUCTION

Curating architecture exhibitions is becoming an intensively engaged practice that strives to expand and enrich the discipline, open it to the public and ground it within a larger social and cultural context. For architectural exhibitions, the curatorial approach, the choice of venue (galleries, conferences and installations), the method of display varies widely and influences greatly the effect of research projects and the perception of ideas for the audience. Following are two personal accounts of curatorial projects conducted to understand how methods of curating exhibitions can affect architectural research and its communication to the community: Building Waterloo Region – No Small Plans and BRIDGE Waterloo Architecture. No Small Plans, installed in a gallery in the traditional format of exhibitions, was an exhibition that told the stories of Canadian Governor General Award-winning buildings in Waterloo Region. It applied contemporary practices of curation in the design of the display to interact with the viewer and effectively communicate ideas. Alternatively, BRIDGE Waterloo Architecture is a student-initiated association that aims to create a public platform where the students of the Waterloo School of Architecture are given the freedom to investigate new ways to curate exhibitions, publications and programs of architectural research.

1.0 BUILDING WATERLOO REGION: NO SMALL PLANS

1.1. No small plans: award-winning buildings in Waterloo Region 1984-2014

The *No Small Plans* exhibition was hosted by the Canadian Clay and Glass Gallery in Waterloo from July 5th to August 31st, 2014, and was curated by Rick Haldenby, Esther E. Shipman and the author. The exhibit celebrated the rich concentration of design culture that is present in Waterloo Region by featuring eight buildings in the region that have received Governor General Awards. Waterloo Region is preceded only by Toronto, Vancouver, and Montreal – the three largest metropolitan centres – as the municipality having the most major award-winning buildings in Canada. Four of the eight buildings, including the Clay and Glass Gallery where the show was held, are situated around the intersection of Erb and Caroline streets, making it the most architecturally significant intersection in the country.

Waterloo Region is a culturally vibrant community that is concerned about design, quality of life and the development of the urban environment. The *No Small Plans* exhibition was only one part of the larger *Building Waterloo Region* program that is “a festival of exhibitions and related events exploring and celebrating the past, present and future of progressive architecture and design excellence in Waterloo Region.” (Building Waterloo Region 2014) Other exhibitions that were a part of this project include: *On the Line*, a virtual exhibition that is a transit oriented cultural guide exploring key areas on the 200 iExpress line; *ReMade*, an exhibition on Post War era buildings in the Region; *Ex-industria*, an exhibition framing industry as the foundation of the region and modern architecture as the vernacular style; *First Builders*; *Street Style*; *Finding Ways*; and *Evolving Urban Landscapes*.

1.2. Analysis

As curators of *No Small Plans*, we had the role of developing the thesis of the show, formulating the narrative and the strategy for how materials were presented to support the message, and making connections and comparisons across the exhibited work. Beyond presenting the work of the architects who created the award-winning buildings, we were careful in considering the format of the exhibition and how that would work with the venue. We also considered what media would be included to reach audiences on multiple levels of engagement. Based on our research findings, we selected material and developed a design scheme that would effectively achieve our thesis for the exhibit. (Figure 1)



Figure 1: Signage detail.



Figure 2: Genealogy graphic.

In schematic design phase, we decided that the objective was to tell the story surrounding each Governor General Award-winning building, showcasing not just striking shots of the final built form but the inspirations, challenges and architects' philosophies behind the design including the decisions involved in the making of the building. To give presence to each distinct narrative, we envisioned clusters of artifacts that would form an assemblage and become what we called pavilions for each building. Like country pavilions at the World Expos, we presented issues that were prevalent to the respective projects, such as institutional vision, social purpose, public space and civic life. In addition to drawings and models, the curators installed videos of interviews with the architects to give life to the stories being told at each display. Although each individual project had its own characteristics, we discovered an intricate connection in the genealogy of the architects who were involved in the making of these buildings, which translated into a designed graphic at the far end of the exhibit. (Figure 2) The Rotunda at the gallery became a shrine to the eight projects while banners of OAA award-winning buildings lined the back wall of the exhibit, celebrating the Region's design excellence. (Figure 3)



Figure 3: OAA Award Wall

The exhibition acted as a dissemination ground for the architecture and design profession to communicate ideas to the public, promoting the design culture existing in the Region. For example, the Kitchener City Hall pavilion explored the significant local design competition that brought about the city’s magnificent civic building. The display highlighted not only the winning entry, but also some of the alternate proposals from the finalists in the competition who would later design other award-winning buildings in the Region. Behind this story is the message that the Region is not only a design-conscious community but also a launch pad for creative practices and innovative ideas.

As with many similar cultural endeavours, a major challenge was to amass enough funding to prepare an effective event. In conjunction with developing the concepts and designs of the show, we placed a tremendous amount of effort on public relations and promoting the festival in order to acquire funding sponsors and in-kind support from partners to produce a successful exhibition. Timing was also difficult to manage because the desired undertakings usually surpassed the amount of time and resources (both human and material) we had available.

We were very fortunate to have the collaboration of *The Canadian Clay and Glass Gallery* for providing the site. (Figure 4) Being one of the eight Governor General Award-winning buildings, the choice was obvious and provided interesting working conditions. The unique architecture of the gallery was designed for displaying three-dimensional objects, so the exhibition hall was large and had few walls, allowing for plenty of daylight. These circumstances worked in advantage with the pavilion scheme that the curators eventually decided on, and the displays were designed to resonate with the materials used in the architecture of the gallery. Since the Clay and Glass gallery is a public venue usually geared towards a different group of people, holding an architecture exhibition there introduced an alternate audience to the field, which helped to disseminate architectural ideas to a wider population.



Figure 4: Panorama of No Small Plans exhibition, Canadian Clay and Glass Gallery, Waterloo, 2014.

1.3. Reflections

No Small Plans was well visited by a variety of people, generating interest in the local public about architectural design and also exposing visitors interested in architecture to the clay and glass that are featured at the gallery. Each constructed display with an interview video and a collection of artifacts told a unique story, filling the vast space of the gallery with a murmur of conversations. The wood and black-painted surfaces of the pavilions complemented the butterfly roof made of similar materials. (Figure 5) At the far end of the exhibit, a genealogy graphic helped to tie all the narratives together, creating a comprehensive review of outstanding architecture in Waterloo Region.



Figure 5: Butterfly roof of the Canadian Clay and Glass Gallery.

Beyond executing a thoughtful show, the complementary lectures, walking tours and Kids-Build-Waterloo activities were just as important to the success of the exhibition. These programs and events helped to engage different audiences and attracted them to learn more about the exhibition, as well as encouraged them to ask questions. Similarly, the design and arrangement of artifacts on the various surfaces of the pavilions promoted the discovery of an interactive story instead of a linear reading of it. (Figure 6) We designed elements, such as the light table, kid's table and sliders to create an interactive display for the visitors' participation.



Figure 1: No Small Plan Canadian Clay and Glass Gallery Pavilion.

Eric Haldenby, one of the executive curators of the show, was directly involved in the stories of several of the award-winning buildings. We started our research based on some of his experiences and, through his connections we scheduled office visits in Toronto to speak to architects about the projects, as well as to gather artifacts pertinent to the narrative. After much deliberation based on what materials we could attain or create, the curators developed the scheme for the design of the pavilions, which was composed of a core that would house the interview video and building model with horizontal and vertical elements that would hold plans and elevations, respectively. From there, we formed the stories we wanted to tell about each building and selected the pieces to position on the display. Although each pavilion was its own entity, we saw from our research that the pavilions were interconnected in many ways, so we were careful about the

relationship between each display and their respective position in the gallery. We considered many ways of showing these connections, including using accent lines that would link the pavilions in physical space; ultimately, due to time constraints, we settled on a graphic wall at the far end of the exhibition.

The construction period of the actually displays was short, just over two weeks; a prototype made from foam core was tested only a week in advance to check that the dimensions of the pavilions would work with the designs. In the month leading up to the opening, students and friends of the School of Architecture provided a lot of support and manpower to realize the overwhelming ambitions of this exhibition. Many variables affect the development of these projects, so it would be good practice to allot extra time for delays, as well as to acquire support and buy-in from people who were invested in the undertaking. It was also crucial to our success to communicate and connect with other cultural foundations, to create a comprehensive website, and to generate a strong presence on social media platforms. The completion of an effective exhibition depends not only on the development of a strong thesis but also sound preparations in all aspects of organizing the event.

Although the format of *No Small Plans* was similar to a traditional exhibition, our role as curators had become more engaged in practice beyond the collection of artifacts. The consideration all aspects of the exhibition including the design, the choice of display materials, the supplementary programs and even the promotional items created a comprehensive show that appealed to audiences beyond the architectural field. The integrated design process we used in the creation of this exhibition effectively made a show that was a site of conversation and education that revealed facts about the culture of community to the public that attended the show.

2.0 BRIDGE WATERLOO ARCHITECTURE

BRIDGE is the physical and digital manifestation of the University of Waterloo Architecture student initiatives. It is a community that celebrates and inspires students to not just learn about architecture but to live it. BRIDGE is the medium that provides students with the space and the voice to identify the student body and our critical view of architecture and design. It is our dedication and founding mission that BRIDGE will continue to provide opportunities for students to experiment, collaborate, and communicate all aspects of architectural design.

Our goal is to become the communal hub for students in the dialogue of all things architectural and to engage the immediate community of Galt Ontario and the University of Waterloo with our collective curation and discussion of architecture and design. Our efforts are to set an identity for the students in which to continue our contribution to the greater global dialogue of architectural discourse.

Currently in the planning stages, BRIDGE Storefront will be a multipurpose space for lectures, workshops, meetings, gallery shows, and various other events. BRIDGE Storefront will create a public presence for the UWSA, activating downtown Cambridge through student and community interest in architecture and design.

2.1. Engi-tecture art show and pecha kucha: creativepProjects

The first official BRIDGE exhibition was the Engi-tecture Art Show that was set up at 60 Main St. in Cambridge, Ontario during July 2014. It showcased artworks by eighteen students and faculty from the University of Waterloo's engineering, architecture and urban design programs in a collaborative art exhibition. Aligned with our mission to offer a platform for students to express their interest in and perspectives on design, the art show was initiated by a fourth year architecture student who was inspired by a similar project she encountered while on an internship and who wanted to use the space as a platform to discover and present the hidden talents of creative engineers and architects. Similarly, the Pecha Kucha that was organized as the closing event for the Engi-tecture Art Show focused on presentations about creative projects that students at the school are involved in. The Pecha Kucha Night was a joint venture between the University of Waterloo Graduate Student Association and the Society of Waterloo Architecture Graduates, with BRIDGE as the host of the space for the first of a series of Pecha Kucha Nights for the Waterloo City Chapter. (Figure 8) These events were published in the Cambridge Times to be promoted to the community.



Figure 8: Presentation at the pecha kucha night (Photography by Zak Fish 2014).

2.2. BRIDGE foundation and development

The ambitions of BRIDGE began with the Rome Show of the 2012 Graduating class of architecture students. As a part of Waterloo's architecture program, the first term of fourth year is spent in Rome, and during following summer in Cambridge, the students are given the opportunity to curate an exhibition to share their experiences abroad. Traditionally, the exhibition was a one-night event shared amongst peers and professors, but the class wished to go beyond that and present their work to the greater Cambridge community. In the end, with the generous offer of a local developer, the show was held for a weekend in a vacant storefront on Main St. (Figure 9)



Figure 9: Rome Show 2012.

After the Rome Show, the developer saw the opportunity for similar events to activate the main street and proposed to provide the students of the School of Architecture with one of the many vacant spaces his company owns on Main Street to pursue such endeavours. In response to the offer, a group of students formed BRIDGE and developed the many aspects of creating the framework that would support the vision and the organization of the space. There were many delays and obstacles associated with the physical storefront space, but BRIDGE built a solid foundation with their website to kick off their aspirations for the group. Currently, we are approaching the final push into a permanent storefront space, while maintaining momentum through pop-up events in a temporary location. In collaboration with other associations, groups and community partners, BRIDGE continues to engage with different methods to enrich the cultural identity of the School of Architecture and the local community.

2.3. Potential

A storefront space holds great potential for alternative work in design and architecture because of the characteristics the space gains with its relationship to the street and the public realm. The space can be a workshop for students to develop ideas with research and experiments or a gallery where they can present their work to the public, also making it a useful educational tool. The ability to step outside the institution and work on projects of interest in the real world puts students' ventures into another dimension of professional practice. Furthermore, it is a place where synergy can occur because the flexible setting gives students the opportunity to engage with other people who may specialize in different areas. This arrangement allows individuals and groups to explore the expanding field of architecture with activities such as Pecha Kucha Nights, paint parties, collaborative art shows, movie screenings, workshops, interactive installations, etc.

The storefront presents a myriad of latent opportunities for curators and collaborators to develop. Beyond presenting work and putting on exhibitions, BRIDGE conducts strategic meetings to discuss future undertakings such as setting up e-commerce, generating content for the website, building community connections and attracting project partnership ideas. For the organization to flourish, it is important to keep the mission and goal alive through multiple streams of engagement. Currently, the association is gaining numerous local partners such as store/gallery owners, food bank, and private developers. These partners bring potential joint projects such as Night of Postcards, 100 notebooks, exhibitions, and design competitions. The Night of Postcards (Figure 10) and the subsequent 100 notebooks project was well engaged by the local community, putting design and architecture in the forefront of the cultural community.



Figure 10: Night of Postcards.

Unlike *No Small Plans*, BRIDGE enacts a different form of curation that allows for an exploration of architectural research in alternative ways. Instead of just collecting artifacts and bringing new perspectives to an existing topic, the association is involved in curating exhibitions and programs that generate original research and ways of communicating architecture to the community. This practice of curating architectural exhibition opens up a field of opportunities for development of architecture.

All in all, the potential benefits of curatorial practice for architecture are profound, allowing for dissemination of architecture and developing an expanded awareness of architecture and the city in the public who inhabit the built environment. Furthermore, it is also a way for students and architects to collaborate with practitioners from different fields to synthesize innovative designs and to learn diverse methods of practice from one another. In many ways, curating architecture is both a reflective and creative exercise that stages the prime conditions for engendering collective ambitions and mediating diverging perspectives through sharing opinions and initiating discourse.

REFERENCES

- BRIDGE Waterloo Architecture. *About BRIDGE*. Aug 24, 2014. <http://waterlooarchitecture.com/bridge/about/> (accessed Sep 29, 2014).
- Building Waterloo Region. *Building Waterloo Region*. June 1, 2014. <http://buildingwaterlooregion.ca/#top> (accessed Sept 11, 2014).

IN PROGRESS

An architecturally optimized mono-nitrogen oxide reducing modular photo-catalytic concrete skin

Meredith Sattler¹, Matthew McKeever¹, Katie Pitre¹, Robert Ketner¹

¹Cal Poly San Luis Obispo, San Luis Obispo, CA

ABSTRACT: Mono-nitrogen oxides (NO_x) are common urban outdoor air pollutants that result in acid rain, atmospheric ozone depletion, and severe health issues including chronic asthma, learning disabilities in children, and mortality. This research leverages the large surface areas of southern facing building facades to chemically neutralize NO_x via a modular photo-catalytic concrete brise-soleil/ rainscreen system. By utilizing a combination of ultraviolet radiation and titanium dioxide (TiO₂) further activated with the performance enhancer strontium aluminate (SrAl₂O₄) not only is air pollution reduced during the day, phosphorescent illumination is also provided at night with luminance levels comparable to electric street lighting. The system provides multiple environmental services without the use of carbon-based fuels, is non-toxic, and produces only inert nitrates as a byproduct of the NO_x neutralizing reaction.

Modular panel designs were tested via both physical and digital models in order to optimize the performance of four criteria: 1. ultraviolet radiation (solar) collection, 2. NO_x neutralization through windspeed reduction and particle trapping, 3. phospholuminescent potential, and 4. additional micro-climactic mitigating properties such as shading, precipitation disbursement, and thermal storage. Ultimately two versions of the modular panel forms were developed, one for climates with large diurnal temperature shifts that leverage the benefits of concrete's thermal mass to create microclimate, and one for small diurnal swing climates which minimizes the thermal mass performance.

The minimized thermal mass system was developed for the predominantly hot/ humid city of Baton Rouge, Louisiana which experiences high levels of NO_x air pollution from both oil refineries and automobile traffic. This system utilizes a thin, flat panel tilted 15 - 30 degrees off vertical to not only maximize ultraviolet collection, but also to deflect precipitation. The maximized thermal mass system was developed for the seasonally variable city of Philadelphia, Pennsylvania which also experiences high levels of NO_x air pollution from both oil refineries and automobile traffic. This system's form is based on a curve that optimizes solar tracking throughout the day. It consists of four modular components that can be configured in multiple forms to produce a filigree skin. These skin systems can be sited adjacent to NO_x sources, significantly reducing the dispersion of NO_x air pollution in dense urban areas, while simultaneously providing additional environmental services.

An integrated platform for building performance analysis using grasshopper

Ajith Rao¹

¹USG

ABSTRACT: Recent developments in building simulation software, coupled with increasing availability of computing power, are allowing architects to effectively move performance analysis of designs into the early stages of the design process. These developments aim to allow for the rapid iteration of design solutions, along with more holistic evaluations that examine various performance criteria of interest in a simultaneous fashion. However, different performance criteria require different modes of analysis, and it is also critical for the user to obtain confidence in the simulation results. This paper describes a prototype tool created using Grasshopper, a visual programming language integrated within the Rhinoceros CAD application that can serve as a platform to merge large amounts of building performance simulation data coupling various performance criteria. A case study is described using the tool where the heat and moisture performance of different wall assemblies are evaluated in parallel. The results are linked to a process that aims to quantify the range of uncertainty surrounding the results, so that the user is able to guide the choice of design parameters in a more accurate manner. The conclusions show that key insights can be quickly obtained using this tool, demonstrating its potential to increase understanding of building performance. Outcomes of this work can also advance the building science knowledge through the development of a novel framework that ties different design-driven performance metrics.

Collaborative leadership: A field theory for architectural practice

Ryan Smith¹, Erin Carraher¹

¹University of Utah, Salt Lake City, UT

ABSTRACT: The transformation to integrated practice will depend on professionals with both technical and inter-personal facility. Much has been researched and written on the technology, techniques and tools of integrated practice. Despite the many resources available on the technique of integrated practice from professional associations, trade organizations, and research institutions, and software vendors, there is remarkably little information available to train and educate professional architects in the social aspects of integrated practice of collaborative process, teams, effective communication and leadership. But before tools and techniques for leading collaborative teams are developed, the profession needs a discipline specific theory on the subject. This paper outlines a field theory on collaborative leadership competencies for architects in order to provide a framework by which the profession can subsequently develop tools for leadership development.

Despite rhetoric surrounding naturally intuitive leadership, the theory outlined in this paper proposes that interpersonal leadership skills are learned, much the way any other technical knowledge is learned. This theory encompasses six knowledge domains based on Beinecke's "Leadership and Management Skills"[ii] and Pete DeLisle's "Leadership Effectiveness"[iii] and peer reviewed by the Center for Integrated Practice of the AIA, by which if continuously developed, architects can lead and manage teams effectively. The six domains include:

1. Design Knowledge: personal or resource knowledge of design principles, material technique, and digital computing capability - this is essential technical knowledge of the building design, or intrinsic knowledge of the discipline.
2. Context Knowledge: policy, program knowledge of stakeholders, policies, codes, contracts, economics, environment, politics, etc. - this might be called extrinsic knowledge of the discipline.
3. Systems Knowledge: transformational, visionary, holistic and systems perspective knowledge of the practice of architecture - its contingencies, capabilities and culpabilities in society.
4. Management Knowledge: transactional, management, reporting, budgeting, and allocation of effort - this is a very tactical knowledge in architecture that makes for effective, efficient project managers.
5. Emotional Knowledge: leader awareness, emotional, interpersonal, communication, and conflict resolution knowledge - this might be called "people" knowledge.
6. Ethical Knowledge: commitment, ethics, self-less, character, hard decisions, servant leadership - this type of knowledge is difficult to teach and tends to be more about upbringing or personal commitment.

After outlining the theory and its justification, the paper will offer a personal evaluation tool for architects to determine their competencies across the six knowledge domains in order to become more effective leaders of collaborative teams.

[ii] Beinecke, Richard H. "Leadership for Wicked Problems". *The Innovation Journal: The Public Sector Innovation Journal*, Volume 14(1), 2009, article 1.

[iii] DeLisle, Pete. "Architect as Leader". *AIA Handbook of Professional Practice*. Wiley, 2014.

Energy modeling of university of Massachusetts-Amherst fine art center, a modernist icon

Carl Focchi¹

¹University of Massachusetts-Amherst, Amherst, Massachusetts

ABSTRACT: Energy conservation and efficiency is essential in contemporary building design. The perception that architects during the Modernist period of architecture ignored these principles is incorrect.

Modernist buildings, in particular the massive concrete constructs characterized as Brutalist, are admired for their complex sculptural form, the construction processes involved, their interplay with site and community, or the social politics of conception, program, and design. At the same time, these same buildings may be denigrated for their scale, materiality, or absence of traditional ornamentation and programmatic clues. Revered or reviled, one fact stands out: most Brutalist buildings are considered poor energy performers.

The architects of these buildings were at the height of their professional careers when called on to design these buildings. All had been educated and were practicing their discipline before the development of sophisticated mechanical systems and superior envelope materials. However, these architects were fully aware of design strategies that maximized occupant comfort, e.g. site positioning, solar shading, load mitigation with thermal mass, glare control, daylighting, and material reflectance. In this paper, we show that these strategies were optimally employed and in doing so, conserve energy.

Our case study is the Fine Art Center (1972-74) at University of Massachusetts-Amherst, a masterpiece of American collegiate Modernism executed in the Brutalist style designed by Pritzker Prize winning architect, Kevin Roche.

The process involves transferring the building's original architectural drawings and specifications into a geometrically accurate 3D digital model. The model is then inserted into energy modeling software, DesignBuilder and Ecotect, where it is programmed with all appropriate materials, mechanical systems, schedules, etc. Then the building is parametrically simulated, e.g. repositioned in orientation, material color and/or reflectance altered or changed completely, geometry of a built projection modified to determine optimization of shading and/or daylighting. We examine the design intent of the architect by quantitatively modeling these and other parameters.

Our findings suggest that the Fine Art Center, as built and situated on the site, does take advantage of many of the above strategies and does so in both expected and unexpected ways. This study advances the body of scholarship on Modernist icons by examining a uniquely under-represented feature of historical buildings—their energy performance. It also offers insight into sustainable building strategies in use before the advent of contemporary technologies and supports their use in both new construction and rehabilitation.

This insight represents a critical step toward the public's understanding of Brutalist architecture. It also helps to advance the aims and intents of contemporary green buildings that use many of the same strategies and constructs. Additionally, our findings from this targeted study are useful in promoting both the broader relevance and impacts of detailed energy studies of historically important buildings. The inventory of this building type is substantial, the embodied energy enormous, and threat of demolition frequent. Efforts at preservation are most worthwhile and may be facilitated if knowledge of energy performance strategies are available and understood.

Implementation of an elevated ground in urban cities

Michelle Hook¹, Loran Newman¹

¹University of Florida, Gainesville FL

ABSTRACT: The horizon exists as an understanding for humans' perspective of what is measured visually and what continues to exist beyond the ability to observe. As architects, we are to challenge the interpretation of this line while still keeping the occupation of a place integrated within the context of the city. A means of doing so is to replicate an existing occupiable horizon with a duplicated one. This incision can then begin to vertically layer the available prospects of the original to service any extended needs.

One such case study can be found in Hong Kong. Research through literature gathered reveals an application of a "Duplicated ground" as termed by Shelton, Karakiewicz, and Kvan in The Making of Hong Kong. This concept was initiated to assist the density created by rapidly growing population of Hong Kong and was started with just one link between two podiums. This concept later grew as a successful means of transportation for pedestrians. During our personal travels in Hong Kong, this method of access became our most dominant route, allowing us to experience the city at multiple dimensions. Another advocate for this concept of pedestrian bridges was Harvey Wiley Corbett with his proposal of the "Modern Venice" in 1924. In the text, Delirious New York, Corbett, a prominent thinker about Manhattans city structure, saw the potential of this concept to create second story pedestrian walkways carved out of the buildings. However this concept superseded its time and is a reality just now being introduced within cities.

This research encourages us to question the three dimensional infrastructure in other cities such as New York City. By creating a new urban layer, the production and interconnectivity of the city would increase and provide aid in the transfer of industry, education and daily living. A similar goal to that of the Architectural Research Centers Consortium's goals in facilitating engaged research intended to develop a more comprehensive infrastructure. Possible nodes of development in the city have already begun to imply this concept of design planning such as the High Line. There are also potential areas that could benefit from this design including the junction of Delancey St. and Essex St. where there are recorded concerns of speeding, red light running, and short crossing times. A possible solution would be to provide alternative methods of pedestrian access through the implementation of an elevated pedestrian bridge.

This presentation serves to explore how we as architects can begin to implement the idea of "Human Scale" back to the infrastructure of a growing urban fabric. Specifically studying the Lower East Side in Manhattan, replicating the horizon that everyday pedestrians occupy and elevating it to podium level allows for increased productivity. This application can also provide a more direct connection of programs in an environment that considers pedestrian safety while also providing additional green space. This investigation corresponds with the open category as one that is redefining the horizon that exists within New York by creating a pedestrian infrastructure. This research also relates to building types and design methods in regards to the fact that we design the podium link with consideration of programs and building types that we are connecting.

New perspectives and future directions of BIM workflows: From digital tectonic to digital fabrication and assemblage

Awilda Rodriguez Carrion¹

¹Oklahoma State University, Stillwater, OK

ABSTRACT: "Architects tend to draw what they can build, and build what they can draw".

William Mitchell, Professor of Architecture and Media Arts and Sciences at MIT

Digital fabrication has expanded the realm of architectural research. Today, many architects are using digital fabrication methods as an alternative to regular construction processes to create custom pieces that can be mass produced, but still meet budget and schedules expectations. Current workflows between parametric/BIM architecture software and CNC are thru CAM software that seeks isolation of 2D elements to be imported for proper toolpathing. Consequently, the entire complex layering of parameters and information gets lost in the process, and it relies on user's clear understanding of setting up the parts on the 3D modeling for all the bits to be efficiently separated. Parametric software and digital fabrication methods such as 3D printing and computer numerically controlled (CNC) technologies have the capability to inform and influence the design process, as well as the final tectonic expression, and promise testing the future of geometric potentials and materials limits.

Building Information Modeling (BIM) has enabled us to coordinate information across different design disciplines and allow us to provide detailed material specifications and tolerances. The current CNC/laser workflows from a virtual model to digital fabrication are unpractical, interrupted by translators. The unfolding of solid geometry into a 2D shape from BIM is not a direct process. Many problems arise from this file conversion where relationship and layers of information vanish. Within the framework of craftsmanship and digital techniques, the process of unfolding, detailing and assembling a form directly impacts the tectonic and rationality of the form. There is a growing interest within the architecture design profession on the exploration and future developments of a seamless workflow from virtual forms to digital fabrication to smart materials.

As digital literacy strengthens and professionals push to uncover new design inquiries, our expectations towards digital tectonic will not only be descriptive geometry but also will want a dynamic tectonic relationship and material intelligence. The future vision for digital workflows needs to explore digital means that flawlessly support prefabrication strategies and intelligently inform the fabrication and assemblies.' As digital fabrication tools evolve a new design paradigm will arise. We could make a case that these are only early examples of emerging technologies that seek to digitize fabrication. MIT professor Neil Gershenfeld argued that current digital processes are still in analog mode and not yet digital since all the intelligence is external to the system and materials don't have information. As stated by Gershenfeld, the future is based on computers that don't control tools but computers that are the tool; where the output of a program rearranges atoms as well as bits². As part of a digital fabrication workshop, we asked architecture students to generate full-scale mock-ups that explored BIM/Parametric architectural skins topologies. This paper examines the current hybrid methods of analog and digital processes to highlights areas for improvement within BIM software as a key link between design to digital fabrication methodology.

Post-petroleum design: Practices and principles

George Elvin¹

¹Ball State University, Muncie, IN

ABSTRACT: As the global supply of oil dwindles and concerns about its use rise, designers are searching for alternatives. An increasing number are choosing to reduce the amount of petrochemicals used in their raw materials, manufacturing processes and product distribution. Some are achieving significant reductions in petrochemical use throughout the entire product lifecycle. By interviewing over 40 industrial designers and architects practicing “post-petroleum design,” the author found that significant reductions in petrochemical use often begin with design. The design intent of the industrial designer or architect in many cases establishes the goal of minimal petrochemical use, which is then achieved through material acquisition, manufacturing, distribution and recycling.

Qualitative analysis of the design processes and their lifecycle repercussions as revealed in the interviews exposed six recurring practices characterizing post-petroleum design: the use of renewable resources, recyclable materials, non-toxic materials, low-energy manufacturing and distribution processes, low-carbon manufacturing and distribution processes, and local artisanry. Of even greater significance is the observation that these six practices often appeared to be manifestations of five post-petroleum design principles: energy flows, cycles, resource balancing, resilience and interdependence. These are, perhaps not coincidentally, also principles of living systems, and this resemblance is further explored in the paper.

The results of this study of post-petroleum design will be of value to architects and their educators in two ways. First, the analysis of interviews with architects reveals specific principles and practices for reducing petrochemical use in architecture. Second, the analysis of interviews with the designers and manufacturers of post-petroleum products and materials, which can be specified by architects, opens new approaches to green building. This study also addresses obstacles to post-petroleum design, including environmental, social, economic and design challenges. And it includes a look forward to emerging post-petroleum practices such as landfill mining, industrial recycling, and the increasing use of nanomaterials and biomaterials.

Systems thinking at the get go

Ray Mann¹

¹University of Massachusetts, Amherst, MA

ABSTRACT: As a practicing architect and an educator, I have long puzzled about the nature of the changing skill set that students now need, in face of paradigmatic shifts in our approach and relationship to the built environment. Advancing building science coursework, integrating LEED certification into the classroom, and so on, are key components, but it is clear that more fundamental shifts need to occur at the inception of a student's architectural education. While I hesitate to call my practice work research, experimentation with new material assemblies and materials is integral to my architecture—it is the subject of an upcoming book. While general design has been my forte, I have spent long hours deep into ASTM texts, conversed with manufacturers about material performance, worked side by side with engineers, fabricators and constructors to try to better resolve the numerous sticking points in our current methods of practice and construction. Distilled to its essence, current education and practice continues to be weak in training us to think and visualize in systems. Systems thinking has emerged in the last half-century as a fundamental underpinning of environmental and economic sciences. Simply put, it puts into practice the notion that objects, forces, ideas, and especially people—interact and are mutually influenced in somewhat predictable but nonetheless dynamic ways. Architects are often quick to claim that they are already systems thinkers—after all we think about circulation systems, structural systems construction systems—but it tends to be a rather delimited version, limited by perceived disciplinary boundaries or by specific components or aspects, and by a historically blunted awareness of the on-the-ground realities of getting a building made. With more rigorous training, we could more meaningfully think through, and design for not only more performatively integrated buildings, but with a comprehensive understanding of building processes from resource extraction to fair labor practices. In other words, with a much more comprehensive spatial, temporal and logistical awareness.

Over the past several years, I have developed a systems-focused introductory curriculum for an architecture studio typically taught in the second semester of the three-year track of a Master of Architecture. At the same time, I have been intensively involved in developing system-based approaches to my practice, from user analysis to material systems and construction logistics. Associated methodologies have also been applied to several design-build projects and courses that brought together practice and teaching directly. This paper explains the methodologies developed in each of these arenas, in the context of ideas put forth by scholar-practitioners such as Susanna Hagan from the UK, Kiel Moe at Harvard, Bill Reed with the Regensis Group, Peter Papesche in Boston. The relationship between systems thinking in the educational context as compared to the professional or constructional context will be articulated. The relative successes and failures of different aspects of the undertaking will be evaluated, against the work of others with similar approaches.

Thermostatic bimetal integrated facade as a micro-climate controller

Kyoung-Hee Kim¹, John Mays¹, Ok-Kyun Im¹

¹University of North Carolina at Charlotte, Charlotte, NC

ABSTRACT: Building energy conservation has attracted much attention as there has been an increasing trend for glass façades. Glass facades offer a positive psychological effect and aesthetics, but lead to a correspondingly high energy transfer both in summer and winter. One of the most effective strategies to enhance energy conservation is to use shading devices to reflect heat energy before it enters the building while maximizing daylighting penetration. In this particular research project, a thermostatic bimetal screen was configured within a double glazed system, acting as a passive shading device. Thermostatic bimetal is a product more commonly found in thermostats or other temperature sensitive devices, but has yet to find much application in a building façade. The compound material, composed of two or more alloys with highly varied coefficients of thermal expansion, allows passive movement as one side expands more than the other. This process is well documented, and can be highly calibrated to different temperature ranges by varying the length, thickness, or alloys of the material.

The primary goal of this project is to carry out preliminary performance analysis of a bimetal shading device and to demonstrate its sustainability potential for contemporary glass facades. Building energy simulation was utilized as a research methodology to quantify energy saving from bimetal and compare it with a typical code complying building. The energy simulation focused on cooling and heating loads for a typical summer design week and winter design week respectively. Additional lighting analysis was carried out to show daylighting potential from a bimetal shading device. The preliminary analysis revealed that there was 15~20% reduction in cooling and heating load from a bimetal shading device compared to a code compliance building. Bimetal shading device provided approximately 500lux daylighting level along building perimeters. Additional environmental benefits from the bimetal shading device include occupant comforts by balancing solar gain and daylight penetration while providing glare control and view-out. Detailed system development and performance assessment will be presented in the conference.

Typological studies for passive design strategies based on coupled measured and modelled data

Ulrike Passe¹, Shan He, Mirka Deza¹, Songzhe Xu¹, Baskar Ganapathysubramanian¹

¹Iowa State University, Ames, IA

ABSTRACT: Preliminary measured and simulated data will be presented from two comparative field studies in Turkey and the United States. The project validates spatial typologies of traditionally inherited passive heating and cooling strategies situated in two distinct climate zones (hot and arid and continental humid). Sustainable buildings today demand a holistic approach towards the design of spaces, envelope systems, occupant behavior, dynamic environmental control strategies; the materials used in the construction, as well as the energy produced, used and stored in the building. This is specifically important in the developing world where high tech solutions might not always be available therefore passive strategies which use the building fabric to mediate the climate are essential to meet the needs of a warming planet. Our overarching research goal is to enhance the utilization of naturally occurring energy flows through, within or around buildings, their spatial shapes, and their construction materials to achieve thermal comfort, individual control and improved air quality, while eliminating fossil fuel consumption and negative environmental health impacts. Our methodology is the coupling of measured performance data with high performance CFD simulations. The collaborative pilot project presented here studied the fundamental energy flow characteristics executed in the conical roofed Harran houses in Turkey and in the Midwestern sun porch. The long-term goal of the research project, once the fluid dynamics in those buildings is understood and modeled is to develop typology guidelines for passive cooling and heating strategies for extreme climates. This international collaboration aims for transformative impact on building design for the extreme climates as encountered in the hot and arid Middle East and the continental humid climate of the US Midwest. The outcome is a validated knowledge base for passive design strategies, which can be integrated into contemporary designs for sustainable high performance buildings through dynamic building information modeling.

Urban resilience: Measuring place identity in sustainable communities

Celen Pasalar¹, George D Hallowell¹, Aliaa Elabd²

¹North Carolina State University College of Design Raleigh, NC

²Alfaisal University, Riyadh, KSA

ABSTRACT: During the last half-century, Marc Fried (1963) and generations of other researchers have found that place identity, place attachment and other people-place relationships are fundamental to the successful development of resilient communities. These complex socio-spatial frameworks are essential to welding a loose array of physical streets and blocks into a sense of community (Fried, 2000). Studies indicate that place identity is related to increased levels of stability, livability and resilience. Place identity is a multi-dimensional construct incorporating several aspects of people-place bonding and various mutually defining socio-psychological characteristics. Research suggests that social amenities, residential choices, demographics, local social networks, individual needs, and personality styles determine the strength of the connection to a place. Unfortunately for urban designers, most previous studies have lacked a focus on the relationship between measurable formal / spatial aspects of a neighborhood and a resident's level of place identity. Earlier research has focused instead on a resident's identification with a geographically defined group of people and not to the physical place itself or its features. As a result, connections between measurable physical characteristics and socio-psychological place identity metrics are vague at best, and the role of place identity in planning theory and design practice has been sorely neglected.

Using data derived from a broader research project, this study aims to understand and analyze a portion of Raleigh, NC in terms of its formal, spatial and social characteristics. The larger project, "Uncovering Southwest Raleigh," was focused on understanding current and future forces affecting change in order to develop strategies to enable the residents of the Southwest quadrant of Raleigh to enhance and promote a healthy, creative and economically sustainable future for the district. The primary goal in the current study is to discover the physical measurable characteristics in the built environment that relate to nurturing socio-psychological aspects, such as place identity, on a neighborhood level. The objective in this study is to broaden the understanding of the relationship between a neighborhood's physical and social characteristics. This study employed a well-tested socio-metric, the Urban Identity Scale (UIS) deployed in the form of an online survey instrument. The results of the UIS were then compared to various measurable physical characteristics of the included neighborhoods. The 758 survey responses derived through this exploration were then analyzed using a correlational approach and compared to data derived from multiple collection techniques, including robust socio-economic and demographic data, interviews, and extensive geographic Information System (GIS) map data.

/// FUTURE of Architectural Research

Research in architecture, design and the built environment is currently diversifying and reaching new directions. Technological changes, such as new materials, construction techniques and design representations, have accelerated the need for research within design disciplines. Today, research is more important than ever and it is also becoming an integral component in the design practices. The theme of ARCC 2015 Conference, the **FUTURE** of Architectural Research, addresses these aspects and aims to set the course for the future direction of architectural research. Today, interdisciplinary research approaches that address advanced materials, building technologies, environmental and energy concerns, computational design, automation in construction, design delivery methods, and project management are essential for advancing the state of knowledge relating to the design of built environment.

CONFERENCE THEMES:

- **Advanced Materials and Building Technologies:** materials, their performance and applications in architectural design, experimental studies, building technologies and implementations in current design projects.
- **Environmental, Energy and Building Performance Factors:** environmental and energy aspects in buildings and cities, high-performance buildings.
- **Computational Design:** computational tools and approaches for design, BIM, parametric modeling, simulations and modeling, use of virtual reality for design.
- **Social and Behavioral Research:** building use and operation, post-occupancy evaluations, and occupant satisfaction.
- **Building Types and Design Methods:** specific building types and their design methods.
- **Research in Practice:** new modes of research specifically suited for design practices, appropriate methods, and implementation of results.
- **Research and Education in Academia:** new modes of research in academic settings, integration of educational curricula and research.

PERKINS+WILL

UMassAmherst

© 2015 All Rights Reserved

ISBN 978-0-9847582-0-3
9 0000 >



9 780984 758203