



BRICK RAINSCREEN SYSTEM



Telling Architectural Systems, LLC



Corium™ is the brick cladding system brand of Wienerberger Ltd.



Offered in North America by:



Telling Architectural Systems, LLC

www.tellingarchitectural.com



About

Use and Installation

Corium™ brick rainscreen is installed by carpenters, glazers, sheet metal contractors, and of course brick masons who can work from mobile platforms, scissor lifts, mast climbers or traditional scaffolding.

Corium can be installed over a wide variety of substrates including concrete, light gauge metal framing, masonry and wood framing. Corium is installed with interlocking horizontal trays attached to vertical supports at 32" on center. The interlocking horizontal trays increase the strength of the framing. Corium bricks are simply clipped into place. The trays ensure precision and consistent joint lines. At 32" max centers, the Corium installer attaches the support trays, clips in the tiles and finishes the joints with pumped mortar.

Simplicity

Once bricks are installed the Parex Historic Mortar KL which has been formulated for use with Corium is installed. The Historic Mortar is a lime based mix and can be applied using several methods of pumping from hand held to peristaltic pumps. The preferred point profile is bucket-handle.

Design and Technical Support

We offer comprehensive CAD/BIM design assist service to help ensure your vision becomes reality. The Corium/Telling team offers detailed technical, product and design assistance on the use of the system and its applications, and are pleased to provide constructive comments to the design.

Drained/Back-ventilated Rainscreens:

DBV rainscreen involves the assumption that water enters the cavity in limited amounts and is prevented from entering the building by the waterproofing. Additionally, the moisture can easily dry since the cavity is vented, causing the water to simply evaporate.

The system in force in most panel installations does not pressure equalize because of the upward or downward or sideways flow of air in a large cavity.

For example, if the pressure is 20 psf at the top of the wall and 15 psf at the bottom of the wall, there will probably never be 20 psf pushing back out of the cavity joints because the pressure simply migrates to a lower pressure point in the large cavity.

Therefore the planned scenario is that at least small amounts of water will enter... but then dry out due to the ventilation that is free flowing and available.



DRAINED/BACK-VENTILATED RAINSCREEN





A S S E M B L Y

- Light gauge steel framing, concrete or grouted CMU back-up
- AWB membrane
- Mineral wool Insulation – Variable depth up to 8”
- Cavity – 1.5 inches in depth for positive ventilation
- Framing – Wall Brackets and vertical supports designed to accommodate thickness of insulation and cavity. Brackets are thermally isolated and adjustable to offset irregularities in substrate
- Supports run perpendicular to trays
- Trays – Interlocking and Profiled trays to hold the brick tiles
- Brick Tiles – Inserted into the trays
- Lime mortar





- Multi-directional, unlimited bonds, patterns, soffits, ceilings
- Lightweight – only 14 pounds psf
- Speed – one third less time of traditional brick
- Strong, durable, proven experience
- Rainscreen design
- Uninterrupted air/moisture barrier with continuous insulation
- Water management with open cavity for moisture egress
- Long life
- Quality control
- Independently tested and certified



Sizes

1/2" Mortar Joint Between Bricks

Brick Type	Specified Size H x L	Nominal Size H x L	Vertical Course
Modular	2 1/4" x 7 5/8"	2 2/3" x 8"	3 courses = 8"
Norman	2 1/4" x 11 5/8"	2 2/3" x 12"	3 courses = 8"
Utility	3 5/8" x 11 5/8"	4" x 12"	3 courses = 12"



Shapes

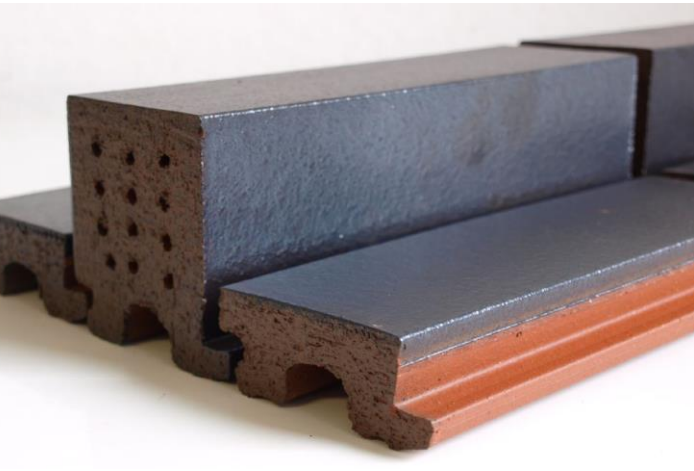

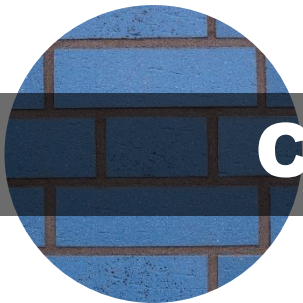

Colors and Textures



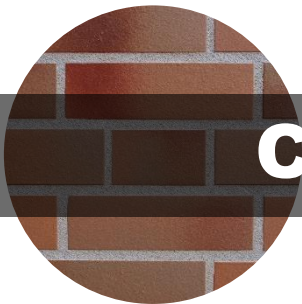

Colors and Textures









DRAINED/BACK-VENTILATED RAINSCREEN

WALL SECTION

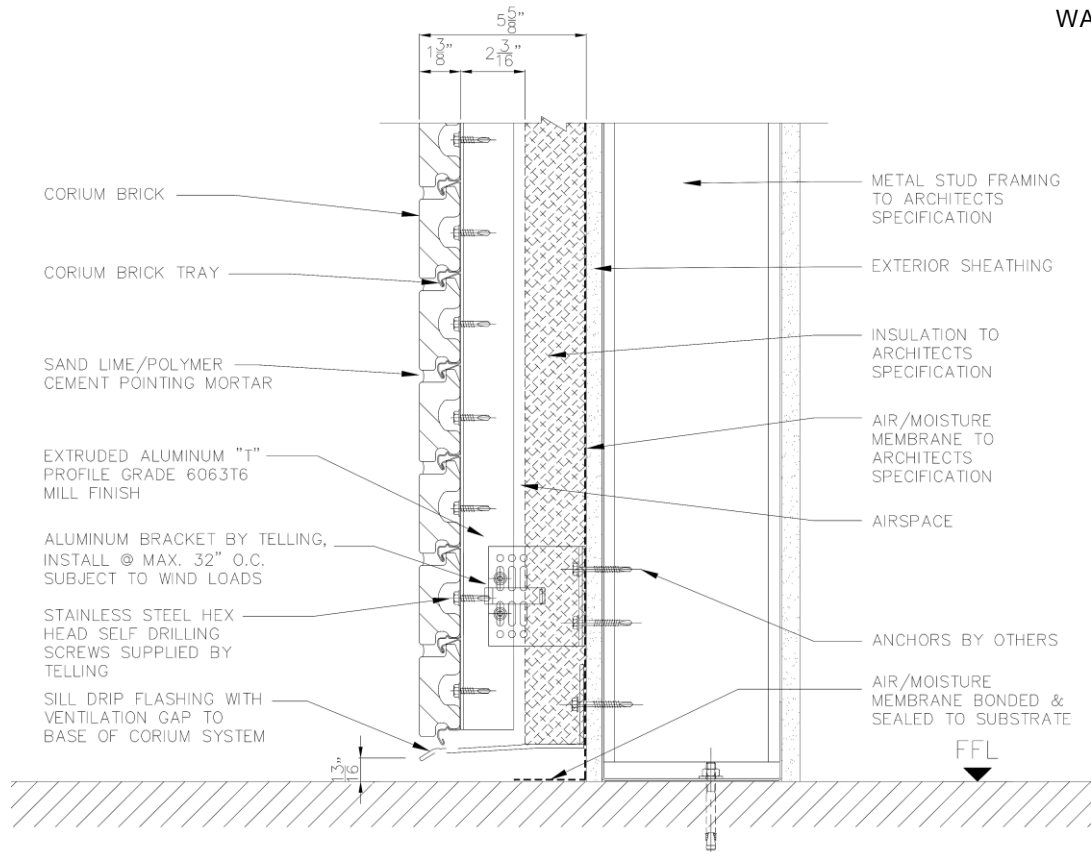

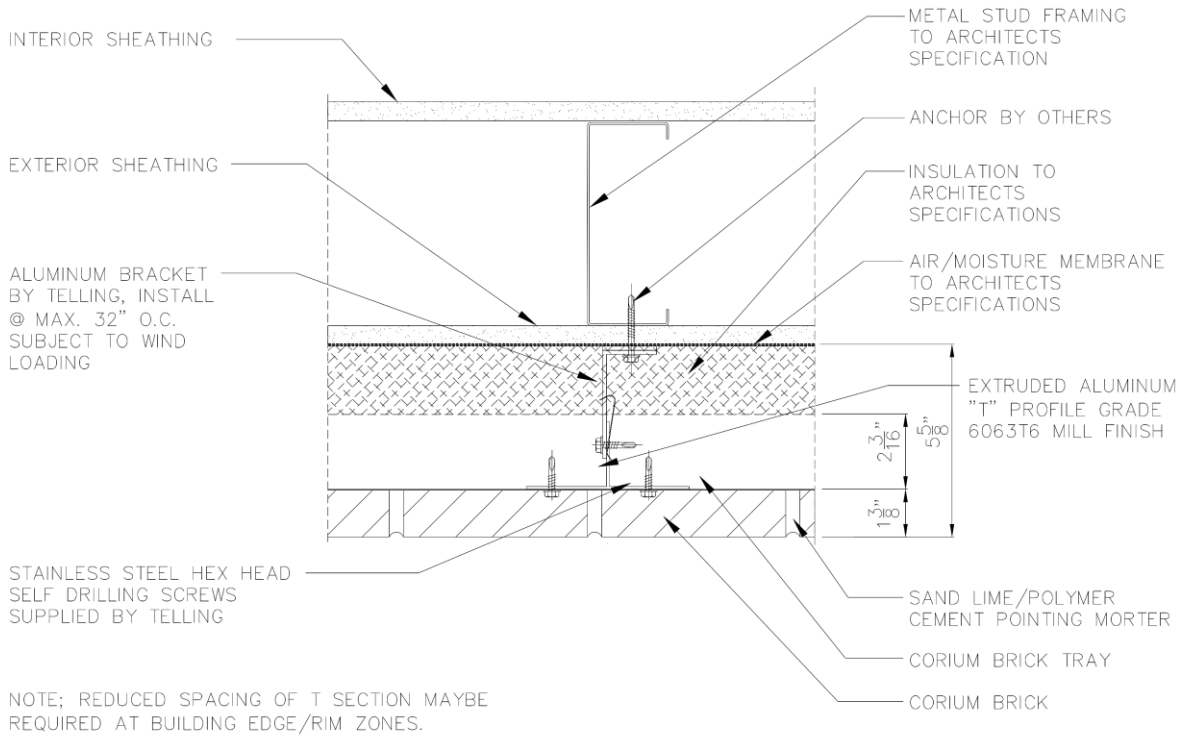

PLAN VIEW

DRAINED/BACK-VENTILATED RAINSCREEN

SILL DETAIL

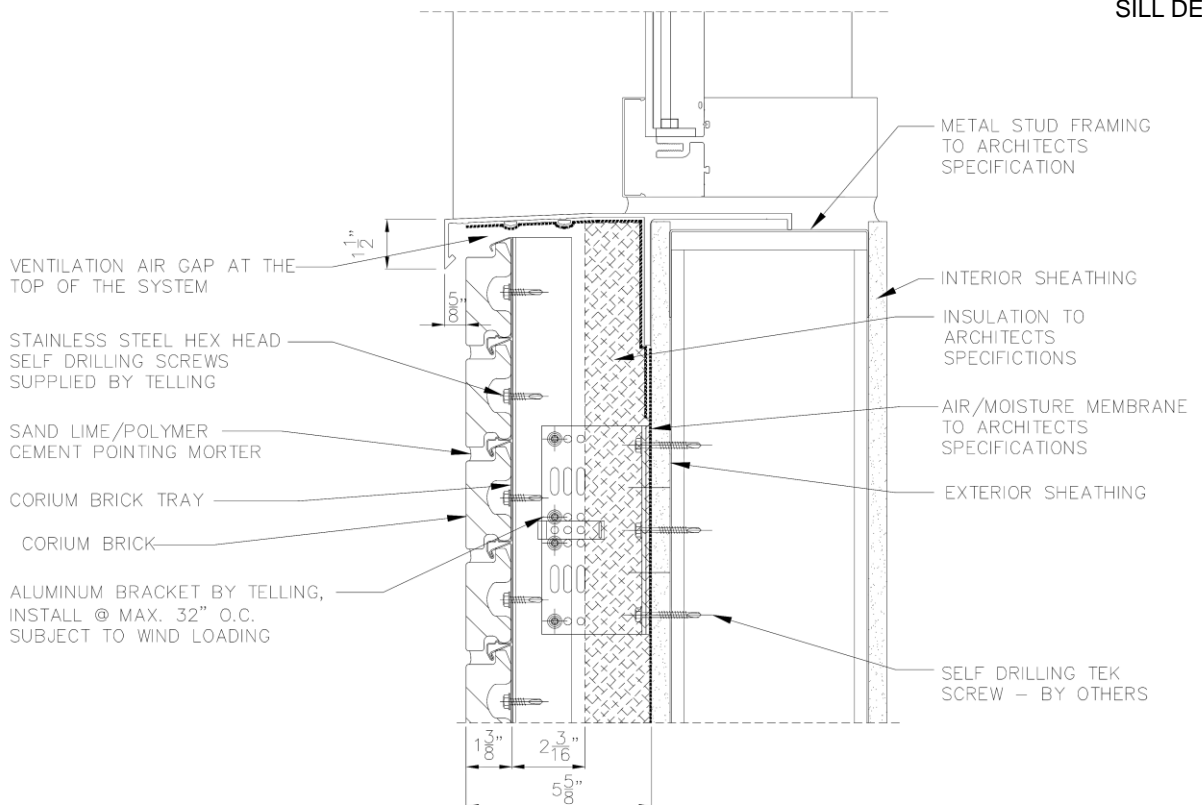

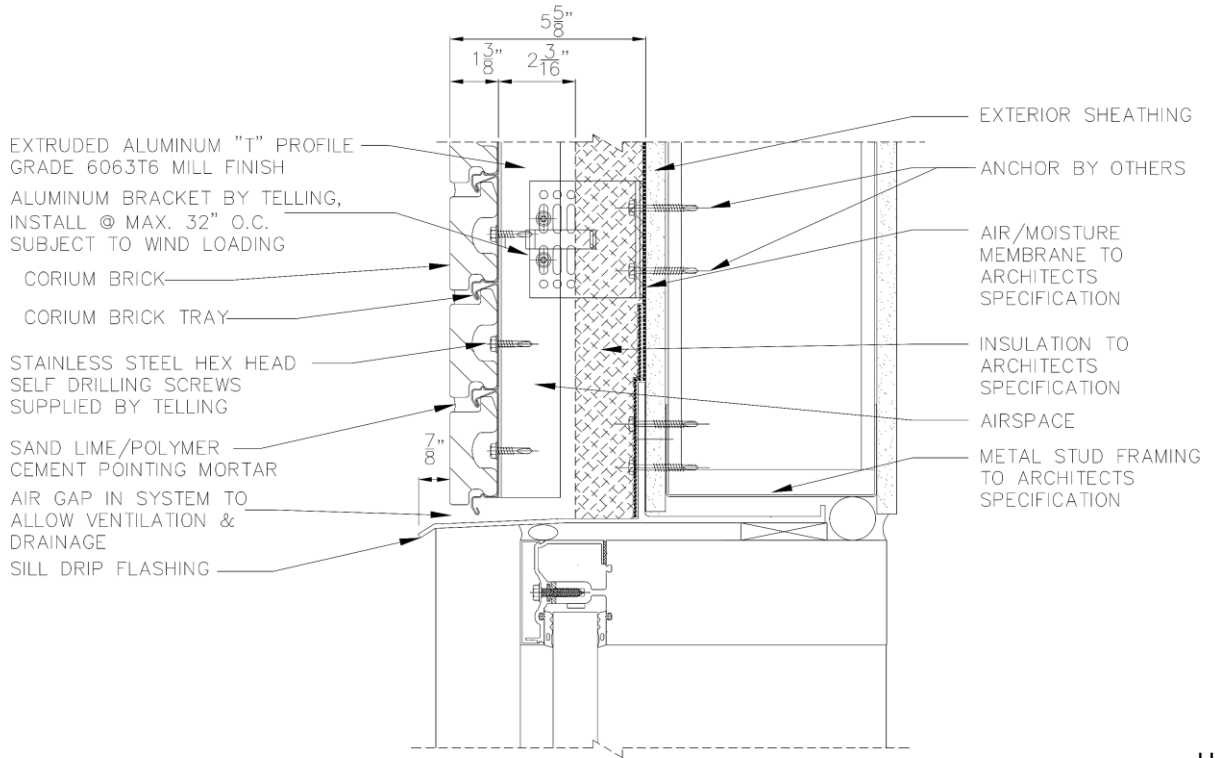

DRAINED/BACK-VENTILATED RAINSCREEN

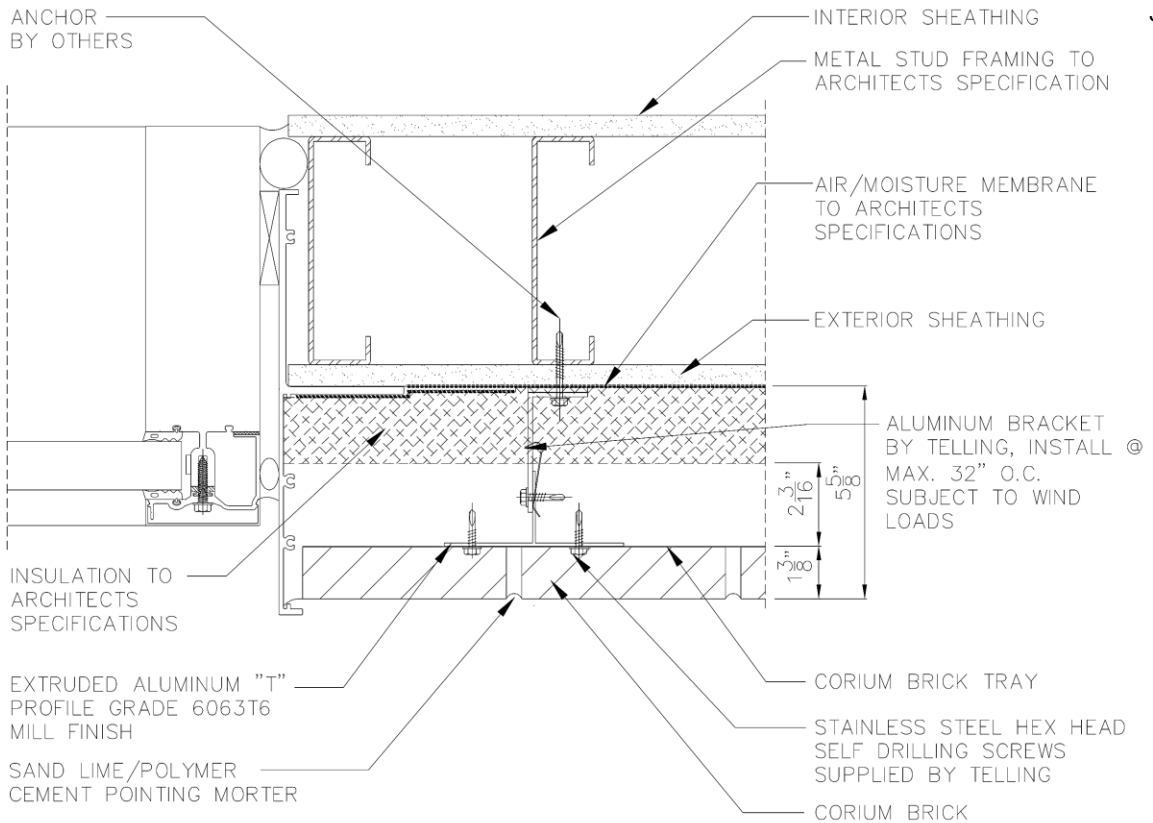

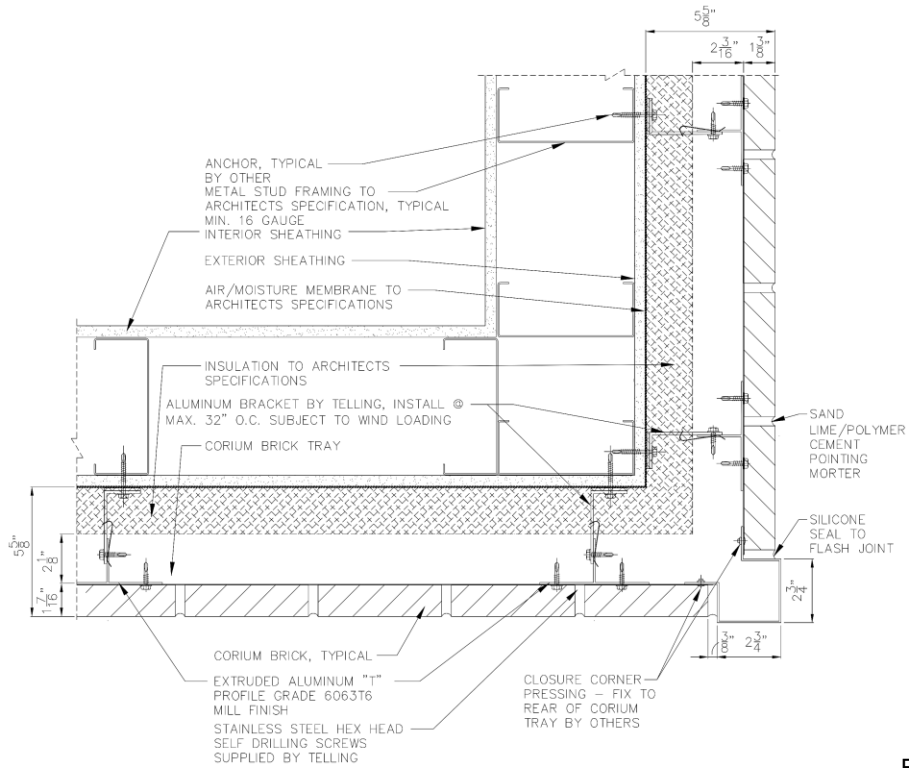

EXTERNAL CORNER

DRAINED/BACK-VENTILATED RAINSCREEN

INTERNAL CORNER

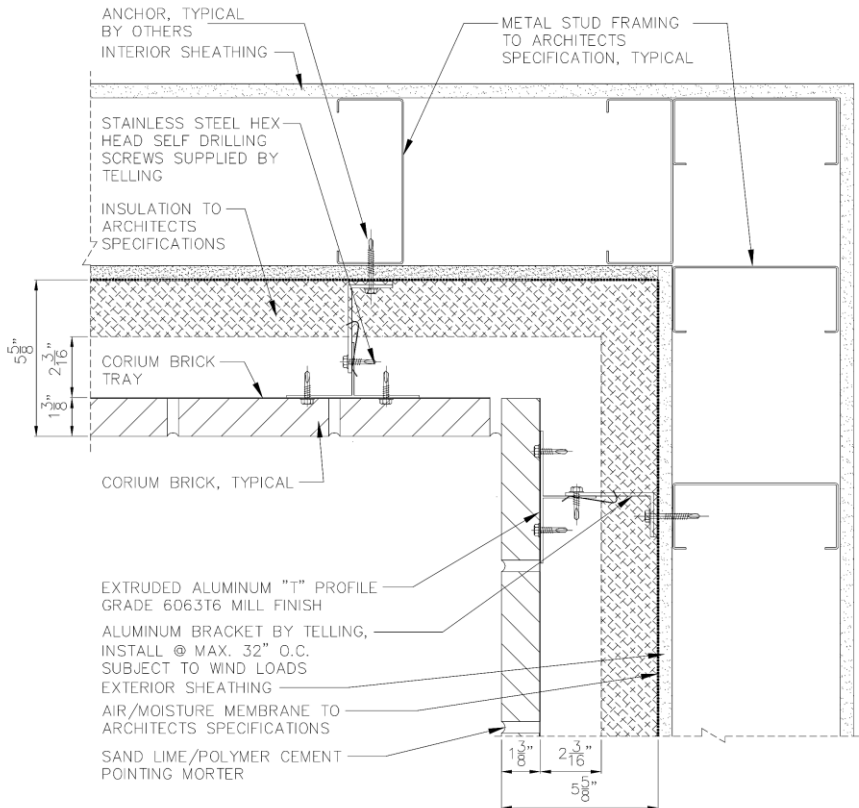

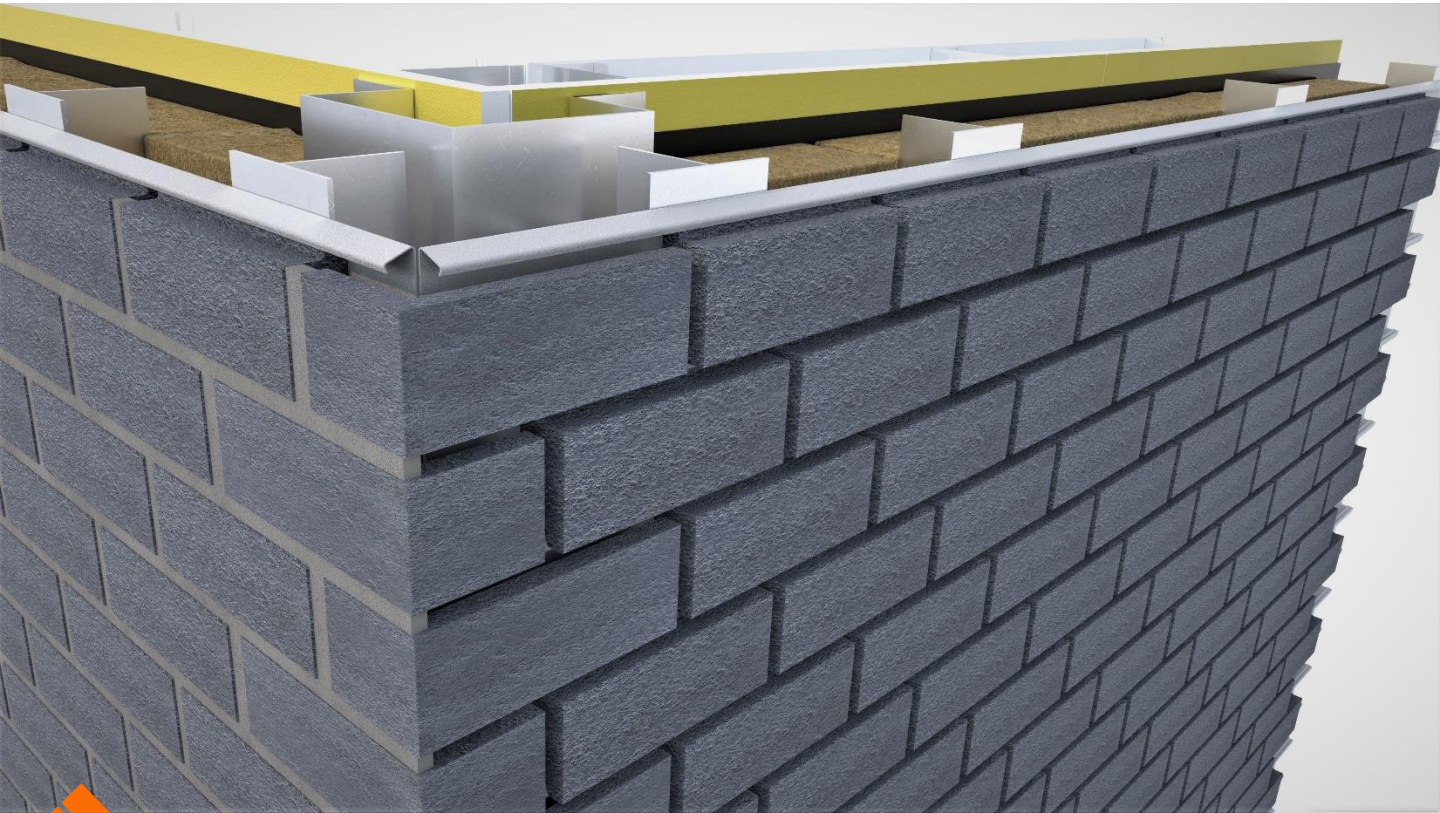

TESTING

TESTED ASSEMBLY-

(7) 9 gauge vertical aluminum 2" deep 'Z' sections were fixed 6" from edge and at 16" through the sheathing to the stud behind using 1/4" x 2" stainless steel hexagon head coarse thread. (39) proprietary HPS200 Colorcoat™ steel brick trays were fastened in to the vertical 'Z's using 3/16" x 1" stainless steel hexagon head coarse thread screws. The trays interlock. The brick slips are inserted into trays using spacers to maintain 3/8" vertical joints between the brick slips. The slips are built stagger bond or stacked. The mortar joints were pointed manually with an Eastpointe Historic natural hydraulic lime mortar.

REFERENCE STANDARDS:

- AAMA 501.1 Water Penetration
- AAMA 501.5 Thermal Cycling
- ASTM E283-04 Air Leakage
- ASTM 331-00 (2009) – Water Penetration
- ASTM 330-02 (2010) Structural Performance, Air & Water
- Freeze/Thaw – 100 Cycles
- ASTM E136 (Noncombustible)

Modular Wall Construction



CORIUM™ is 1/3 the weight of face brick, is mechanically attached to a steel substrate and utilizes a flexible mortar, making the system perfectly suited for off-site panelization.

Having completed a number of modular projects in Europe and North America, we can provide experience and technical support to help clients design, engineer and construct these efficient assemblies.

Benefits of modular wall construction include speed of enclosure, better quality control, cost, less weather dependent. Also consider that modular wall construction is gaining traction in the US and Canada and that products and systems designed to meet the increased demand give designers and sub-contractors a competitive edge.

DRAINED/BACK-VENTILATED RAINSCREEN





PROJECT

Project:	6-26 New Street "The Eddy"
Location:	Boston, MA
Year Completed:	2016
Color/Blend:	92100
Architect:	Copley Wolff Design Group / Stantec





PROJECT

Project: 169 Canal Street
Location: Providence, RI
Year Completed: 2018
Color/Blend: 13000 (50%), 16001 glazed (30%), 16000 (20%)
Architect: DBVW Architects

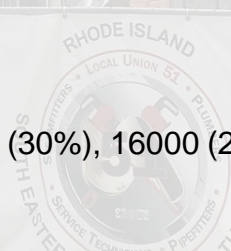



PROJECT

Project:	2300 Wilshire Blvd.
Location:	Santa Monica, CA
Year Completed:	2018
Color/Blend:	92100
Architect:	dfh Architects





PROJECT

Project:	Washington Performing Arts Center
Location:	Olympia, WA
Year Completed:	2014
Color/Blend:	5 color blend
Architect:	MSG Architects





PROJECT

Project: Loyola University Monroe Hall Renovation
Location: New Orleans, LA
Year Completed: 2013
Color/Blend: 74010, 10030
Architect: Holly & Smith Architects



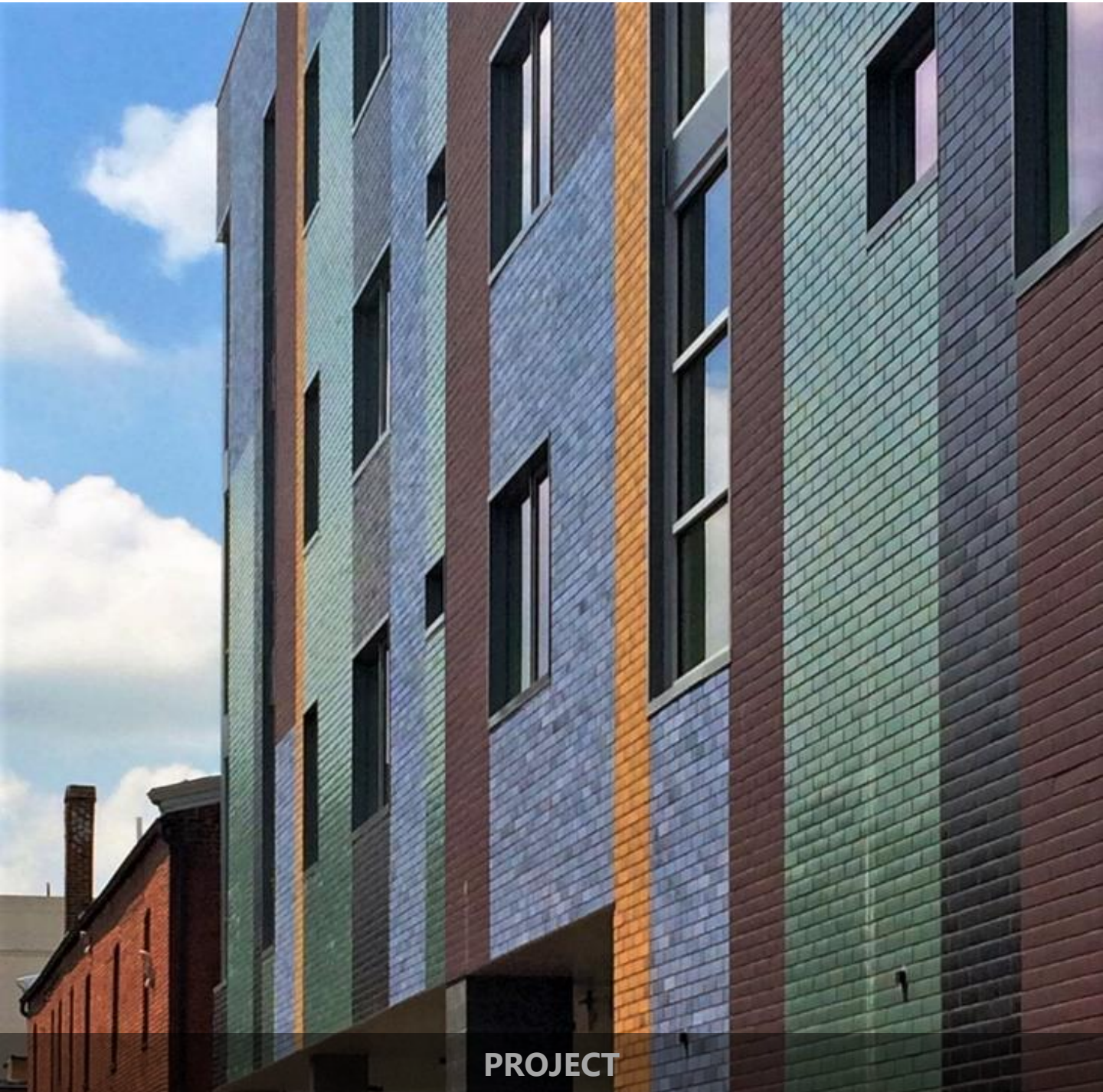

PROJECT

Project:	Bailey Flats at Blagden Alley
Location:	Washington DC
Year Completed:	2015
Color/Blend:	Multi-glazed, unglazed
Architect:	Suzane Reatig Architecture





PROJECT

Project:	Weavers Quay
Location:	Manchester, UK
Year Completed:	2018
Color/Blend:	Multi-glazed, unglazed
Architect:	Buttress Architects





PROJECT

Project:	Clippership Wharf
Location:	East Boston
Year Completed:	2019
Color/Blend:	Multi-glazed
Architect:	TAT (LEED™ Gold)





Telling Architectural Systems, LLC

125 High Rock Ave, Saratoga Springs NY, 12866
518.886.8745 or toll free 866.271.0488
info@tellingarchitectural.com

(All Rights Reserved®)