

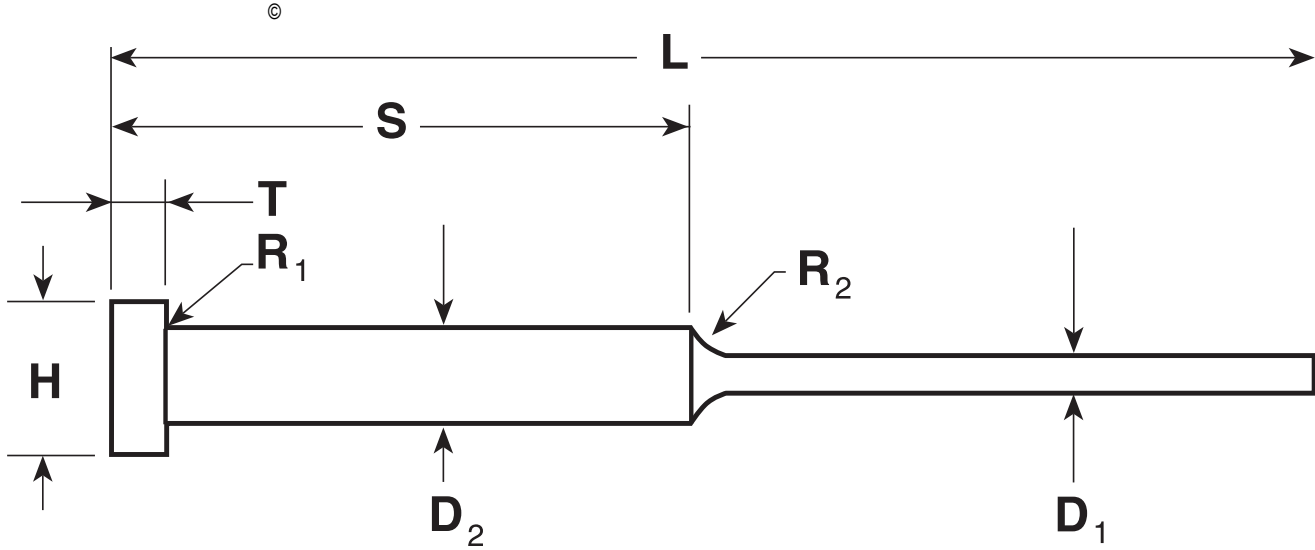

SPECIAL EJECTOR PINS STEPPED

COMPONENT GUYS INC.

QUOTE FORM



Size	Tolerance	✓	Special Tolerance	Quantity
D ₁ =	-.0003 -.0008	<input type="checkbox"/>	or <input type="text"/>	_____
D ₂ =	+.000 -.001	<input type="checkbox"/>	or <input type="text"/>	Material _____
L =	+.060 -.000	<input type="checkbox"/>	or <input type="text"/>	_____
S =	+.000 -.020	<input type="checkbox"/>	or <input type="text"/>	Hardness/Heat Treatment _____
T =	+.000 -.002	<input type="checkbox"/>	or <input type="text"/>	_____
H =	+.000 -.010	<input type="checkbox"/>	or <input type="text"/>	Required Date _____
R ₁ =	1/32 MAX	<input type="checkbox"/>	or <input type="text"/>	_____
R ₂ =	BLEND RADIUS	<input type="checkbox"/>	or <input type="text"/>	_____

Company: _____

Address: _____

City: _____ State/Prov.: _____ Zip/Postal Code: _____

Phone: _____ Email: _____

Contact Name: _____ Reference #: _____

e-mail completed form to: sales@componentguys.com
5345 Outer Dr. Unit#3 , Windsor, On. N9A 6J3 Phone:519-968-3367