

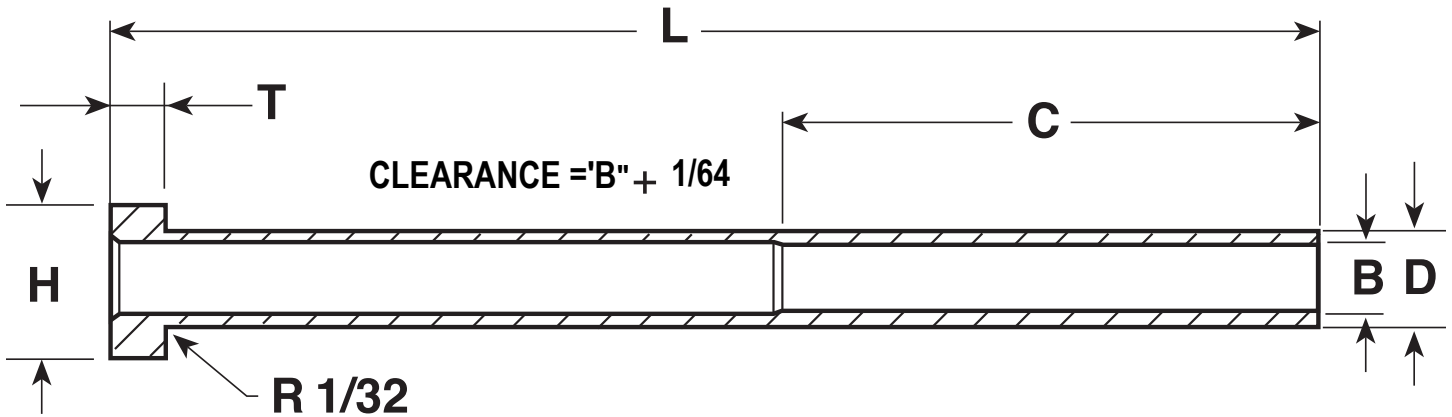

# SPECIAL EJECTOR SLEEVES

## QUOTE FORM

COMPONENT GUYS INC.



	Size	Tolerance	✓	or	Special Tolerance	
<b>D =</b>	<input type="text"/>	-.0003 -.0008	<input type="checkbox"/>	or	<input type="text"/>	Quantity
<b>B =</b>	<input type="text"/>	+.0003 --.0000	<input type="checkbox"/>	or	<input type="text"/>	Material
<b>H =</b>	<input type="text"/>	+.000 -.010	<input type="checkbox"/>	or	<input type="text"/>	Hardness/Heat Treatment
<b>T =</b>	<input type="text"/>	+.000 -.002	<input type="checkbox"/>	or	<input type="text"/>	Required Date
<b>L =</b>	<input type="text"/>	+.031 -.000	<input type="checkbox"/>	or	<input type="text"/>	
<b>C =</b>	<input type="text"/>	+ -	<input type="checkbox"/>	or	<input type="text"/>	

Company: \_\_\_\_\_

Address: \_\_\_\_\_

City: \_\_\_\_\_ State/Prov.: \_\_\_\_\_ Zip/Postal Code: \_\_\_\_\_

Phone: \_\_\_\_\_ Email: \_\_\_\_\_

Contact Name: \_\_\_\_\_ Reference #: \_\_\_\_\_

**e-mail completed form to: [sales@componentguys.com](mailto:sales@componentguys.com)**  
**5345 Outer Dr. Unit#3 , Windsor, On. N9A 6J3 Phone:519-968-3367**