

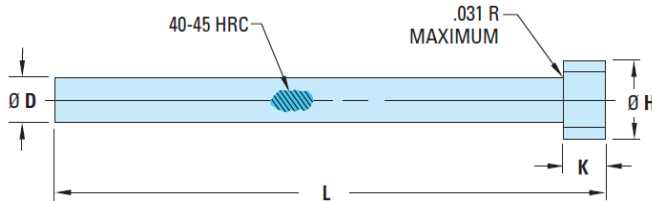

D Head Ejector Pins

COMPONENT GUYS INC.



Material: H-13 / 1.2344 / SKD61
 Surface Treatment: Nitrided
 Surface Hardness: 65-74 HRC
 Core Hardness: 40-45 HRC

Cat. No.	"D" -.0003 -.0008	LENGTH						H	K +.000 -.002
		6"	10"	14"	18"	25"	36"		
DEJP125	1/8"	x06	x10	x14				1/4	1/8
DEJP146	9/64"		x10	x14				1/4	1/8
DEJP156	5/32"	x06	x10	x14	x18	x25		9/32	5/32
DEJP187	3/16"	x06	x10	x14	x18	x25		3/8	3/16
DEJP218	7/32"			x14				13/32	3/16
DEJP250	1/4"	x06	x10	x14	x18	x25	x36	7/16	3/16
DEJP312	5/16"	x06	x10	x14	x18	x25		1/2	1/4
DEJP375	3/8"	x06	x10	x14	x18	x25	x36	5/8	1/4
DEJP437	7/16"			x14				11/16	1/4
DEJP500	1/2"	x06	x10	x14	x18	x25	x36	3/4	1/4
DEJP625	5/8"	x06	x10	x14	x18	x25		7/8	1/4
DEJP750	3/4"	x06	x10	x14	x18	x25		1	1/4
DEJP1	1"	x06	x10	x14	x18	x25	x36	1-1/4	1/4

Precision-machined flat on head keeps pin from rotating
 No machining required

1/8 - 5/16 diameter pins

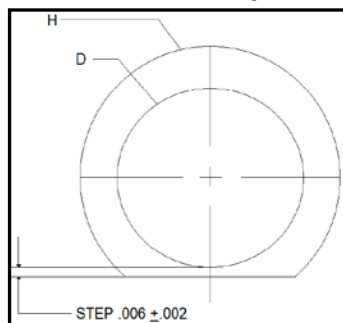

3/8 - 1" diameter pins

