



Air Ejectors

COMPONENT GUYS INC.

Inch Sizes

Designed to assist in breaking the vacuum created when molding deep molded parts or thin walled parts.
Made from 420 Stainless steel 50-55 Rc

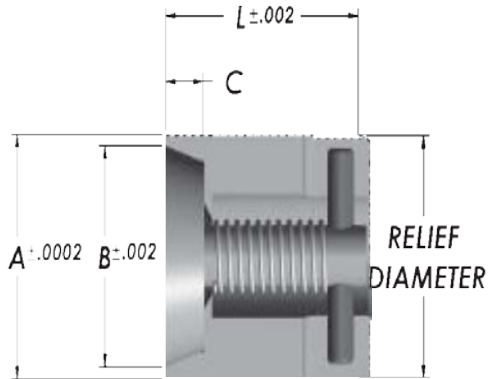

Cat No.	Nominal O.D.	A	B	L	C
AE025	1/4	0.2505	0.225	0.252	0.05
AE037	3/8	0.3755	0.325	0.377	0.07
AE050	1/2	0.5005	0.437	0.502	0.1
AE062	5/8	0.63	0.562	0.627	0.13
AE075	3/4	0.75	0.656	0.752	0.15
AE100	1"	1.00	0.875	1.002	0.2
AE150	1-1/2	1.50	1.312	1.502	0.3

Metric Sizes

Cat No.	Nominal O.D.	A	B	L	C
AE08MM	8	0.3149	6.5	12	1,5
AE10MM	10	0.3937	8	12	2,0
AE12MM	12	0.4724	10	12	2,5
AE16MM	16.00	0.6299	13	20	3
AE20MM	20.00	0.7874	17	20	3,5

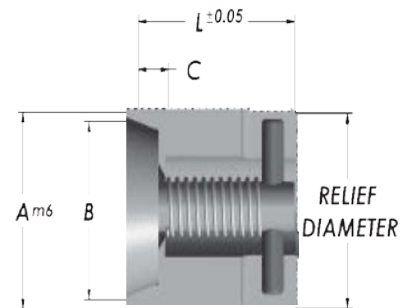

Metric Sizes - Plunger Type

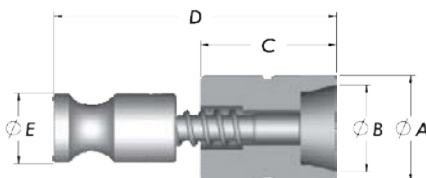

Cat No.	A	B	C	D	E
VA-01	8 $+0,018$ $+0,007$	6,6	11	24	6
VA-02	12 $+0,018$ $+0,007$	9,7	18	34	8
VA-03	18 $+0,018$ $+0,007$	14,8	22	45,5	12