



# PLATE MAGNETS

## CERAMIC

TRAMP MTL 1B (5/99)

### Flush Face

**OPTIONS:**

- Custom Mountings
- Custom Designs
- Tapped Holes
- Clamping Devices

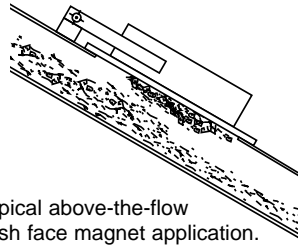

Flush Face	A	B	C	D	E	F	G	H	J	W*
FF50	6	-	-	4-1/8	13/16	1-3/16	1	1-3/4	3-1/2	.9 lbs x "W"
FF100	8	-	-	6-1/8	1-5/16	1-3/16	1	1-3/4	3-1/2	1.8 lbs x "W"
FF200	10	-	-	8-1/8	1-9/16	1-3/16	1	1-3/4	3-1/2	2.3 lbs x "W"
FF300	12	-	-	10-1/8	2-9/16	1-3/16	1	1-5/8	4-1/2	5.0 lbs x "W"
FF500	14	-	-	12-1/8	4-1/16	2-11/16	1	2-5/8	4-1/2	7.5 lbs x "W"
FF800	16	-	-	13-1/4	6-5/8	**	1-1/2	-	-	13.3 lbs x "W"
FF1000	20	-	-	17-1/4	8-1/8	**	1-1/2	-	-	23.5 lbs x "W"
FF1200	26	-	-	23-1/4	8-1/8	**	1-1/2	-	-	33.2 lbs x "W"

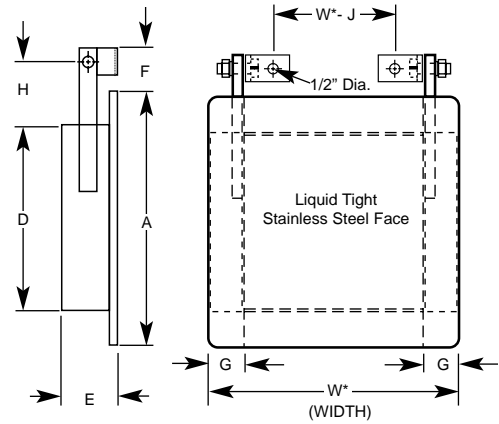

### Exposed Pole

**OPTIONS:**

- Filled Face Between Holes
- Custom Mountings
- Custom Designs
- Tapped Holes
- Clamping Devices

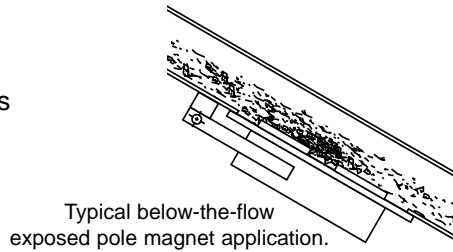

Exposed Pole	A	B	C	D	E	F	G	H	J	W*
EP50	6	4	1-1/2	4-1/8	13/16	1-3/16	1	1-3/4	3-1/2	1.0 lbs x "W"
EP100	8	6	2-1/2	6-1/8	1-5/16	1-3/16	1	1-3/4	3-1/2	2.0 lbs x "W"
EP200	10	8	3-1/2	8-1/8	1-9/16	1-3/16	1	1-3/4	3-1/2	2.5 lbs x "W"
EP300	12	10	4-1/2	10-1/8	2-9/16	1-3/16	1	1-5/8	4-1/2	5.2 lbs x "W"
EP500	14	12	5-1/2	12-1/8	4-1/16	2-11/16	1	2-5/8	4-1/2	7.8 lbs x "W"
EP800	16	13	5-1/2	13-1/4	6-5/8	**	1-1/2	-	-	13.7 lbs x "W"
EP1000	20	17	7-1/2	17-1/4	8-1/8	**	1-1/2	-	-	23.9 lbs x "W"
EP1200	26	23	10	23-1/4	8-1/8	**	1-1/2	-	-	33.8 lbs x "W"

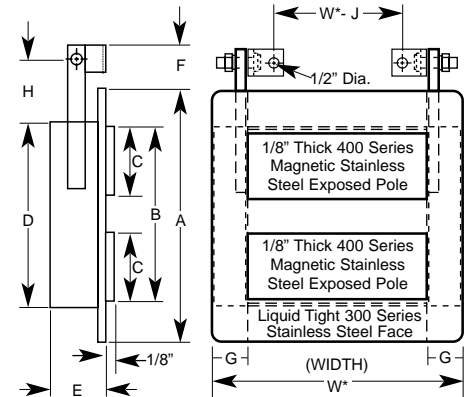

### Spout Magnet

**OPTIONS:**

- Custom Mountings
- Custom Designs
- Tapped Holes
- Clamping Devices

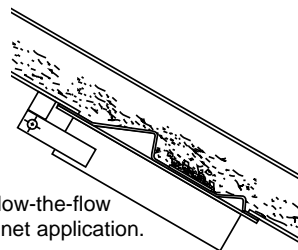

Spout Magnet	A	B	C	D	E	F	G	H	J	W*
SM100	8	3	3/4	6-1/8	1-5/16	1-3/16	1	1-3/4	3-1/2	1.9 lbs x "W"
SM200	10	3	1-1/4	8-1/8	1-9/16	1-3/16	1	1-3/4	3-1/2	2.7 lbs x "W"
SM300	12	3	1-1/4	10-1/8	2-9/16	1-3/16	1	1-5/8	4-1/2	5.3 lbs x "W"
SM500	14	3	1-1/4	12-1/8	4-1/16	2-11/16	1	2-5/8	4-1/2	8.0 lbs x "W"
SM800	16	3	1-1/4	13-1/4	6-5/8	**	1-1/2	-	-	13.9 lbs x "W"
SM1000	20	3	1-1/4	17-1/4	8-1/8	**	1-1/2	-	-	24.2 lbs x "W"
SM1200	26	3	1-1/4	23-1/4	8-1/8	**	1-1/2	-	-	34.2 lbs x "W"

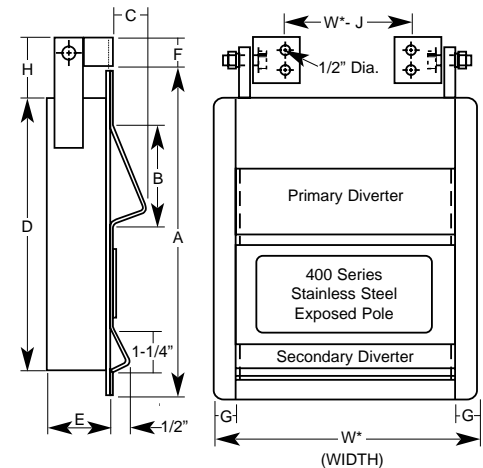

\*\* Hinges available on request. All dimensions stated in inches. NOTE: All 500 Series Plate Magnets have four 1/2" mounting holes.

IMI plate magnets are accepted by Mill Mutual Insurance Company

©1999 Industrial Magnetics, Inc.

**IMI Is Represented By Air Process Systems & Conveyors Co., Inc.**

774 Burr Oak Drive • Westmont, Illinois 60559 • Phone: 630.887.0770 800.822.0771

Fax: 630.887.0771 • Email: Sales@AirProcessSystems.com

**Web: www.AirProcessSystems.com**