

Forberg Fluidized Zone Mixers

Innovative Mixing Technology



- Efficient
- Fast
- Gentle

 **AMERICAN
PROCESS
SYSTEMS**
Member Eirich Group

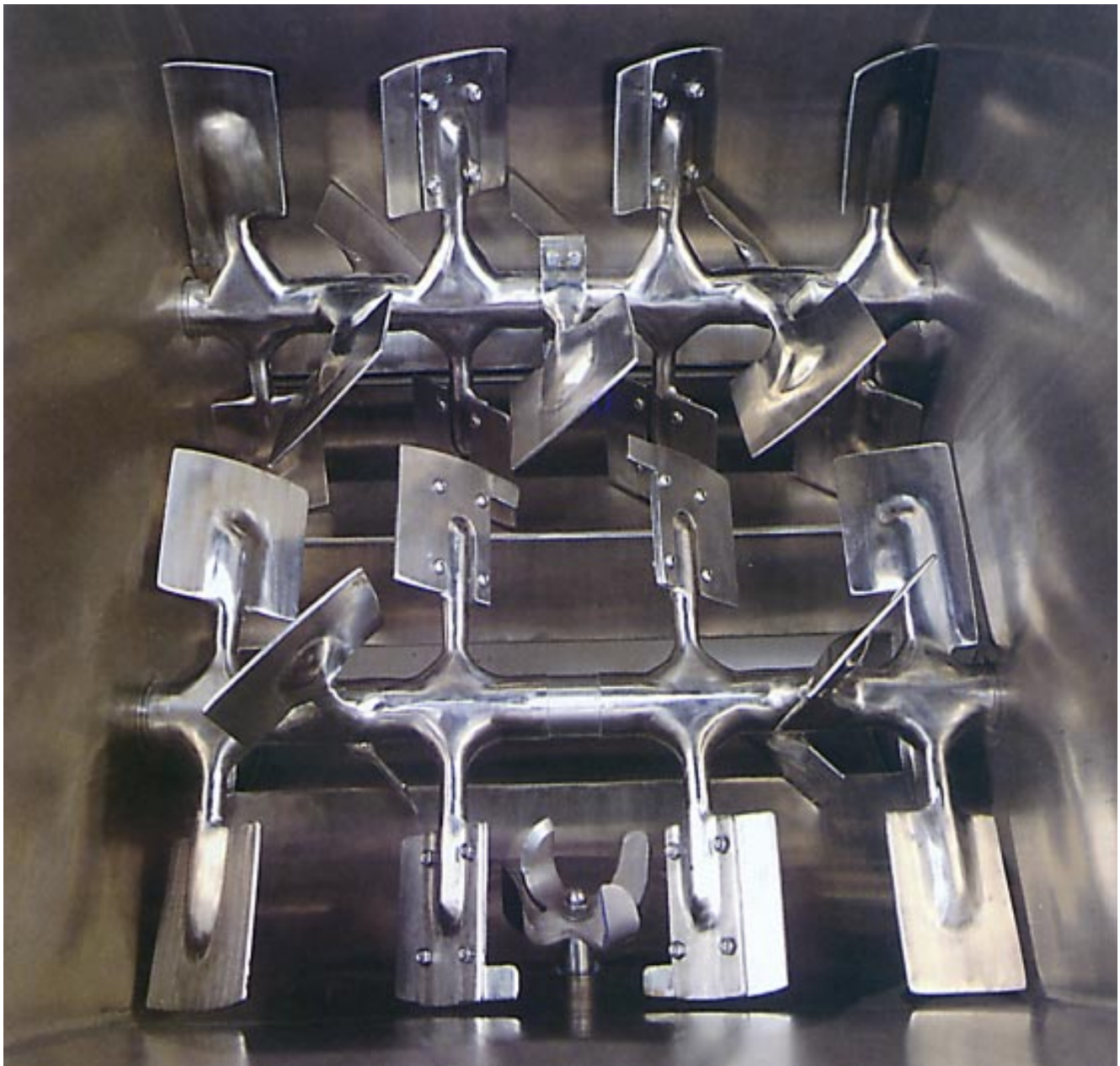

The Fluidized Zone Mixer: Overlapping and counter rotating twin shaft paddle assemblies. Shown with optional chopper.

The Forberg Fluidized Zone Mixer In Action



Start



5 Seconds



10 Seconds

Time interval photos of blending flour, pepper and paprika. Notice the fluidized zone between the rotors in the 5 second interval photo.

The Forberg Fluidized Zone Mixer

Innovative, Patented Technology

The Forberg Fluidized Zone Mixer is internationally patented by the Norwegian inventor Halvor Forberg. American Process Systems as a licensee manufactures these technologically innovative mixers for the American market at our Gurnee, Illinois facility.

Fast, Gentle & Cost Efficient

Fluidized Zone Mixers are capable of preparing a homogenous mix independent of particle size, shape or density. The unique agitation ensures rapid yet gentle blending, short mixing cycles, low operating costs, minimal product degradation and one of the highest production capacities of any mixer type.

Design Features

The mixers consist of twin shaft, overlapping paddle assemblies which are counter rotating at comparatively low rotor speeds drawing material from each rotor drum and lifting the ingredients up and between the rotors. This creates a fluidized zone where particles can freely transpose, thereby eliminating segregation.

Micro-minors of 1 ppm are mixed regardless of where they are added into the mixer. Shear is very low or non-existent and therefore no heat is generated. As a result extremely fragile ingredients such as flakes or whole coffee beans can be blended with minimal degradation.



Put It To The Test

Claims such as 10 to 30 second mixing cycles are almost unheard of and contradict most historical mixing experiences. You may not be able to believe such claims without seeing them for yourself.

We invite you to take advantage of our Customer Participation Test Program. Call us to schedule a test at our in-house test facility to learn and observe firsthand the many benefits of the Fluidized Zone Mixer. Or rent a unit for testing at your plant.

Integrated Systems

The optimum fluidized mixer system would pre-weigh and pre-stage ingredients, then mix and quickly discharge a batch into a large static or agitated surge hopper. Complete systems with feeders or scale hopper above and conveyors below can be tailored to specific project requirements. An example is shown in the sketch below.

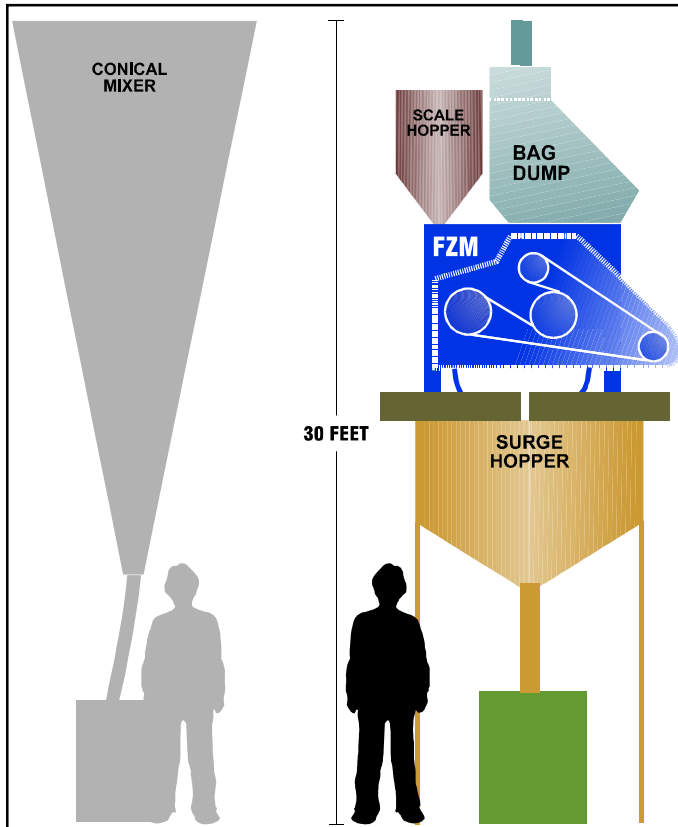

Four times the capacity for the same price in the same space

A bakery ingredient plant quadrupled its capacity by replacing an existing conical screw mixer with an FZM system. Heated flavored oils were sprayed into the fluidized zone to evenly coat sugar making it difficult to mix. Due to its shape, the conical mixer generated excessive friction, caramelizing the sugar based product.

Now a scale hopper delivers a pre-weighed batch of major ingredient (sugar) into the FZM while bags of dusty minors are added through the combination bag dump/delumper. The flavored oils are pumped directly into the sugar mix with a batch mix time of 3 minutes. The wetted sugar drops into an agitated surge hopper mixer with metering screw.

Typical FZM Installations by America

- Powder and granular spice mixes with liquids
- Silica based highway striping
- Aquarium salts
- Pigments with resin above extruder
- IQF (Individually Quick Frozen) vegetables
- Infant formula of milk sugar and protein powders
- Air bag propellant
- Salad croutons with seasonings
- Cocoa powder for cereal coating
- Super absorbent for diapers
- Space shuttle solid rocket booster core
- Coating prilled lawn fertilizer with active ingredients



Lab-sized, portable FZM-0.7 with air-over-liquid spray tank, spray nozzles and NEMA 4X stainless steel starter controls

American Process Systems

- Coating whole bean coffee with flavors
- Granola mix
- De-blocking raisins for cereal
- Frozen meats and vegetables for frozen dinners
- Mortar mix with pigments
- Flavored instant coffee powdered blends
- Clay based herbicide with sprayed on liquid active ingredient
- Animal feeds

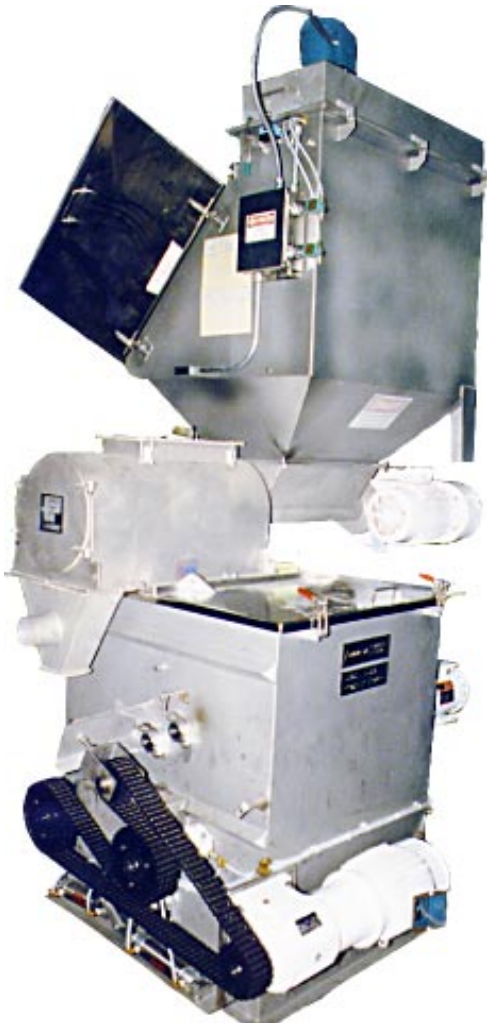

FZM System for cocoa and silicon dioxide cereal coating including filtered bag dump and centrifugal sifter.



Typical system consisting of scale hopper, Forberg fluidized zone mixer, transition hopper to dust control hood for filling IBC's.

Our Competitive Edge

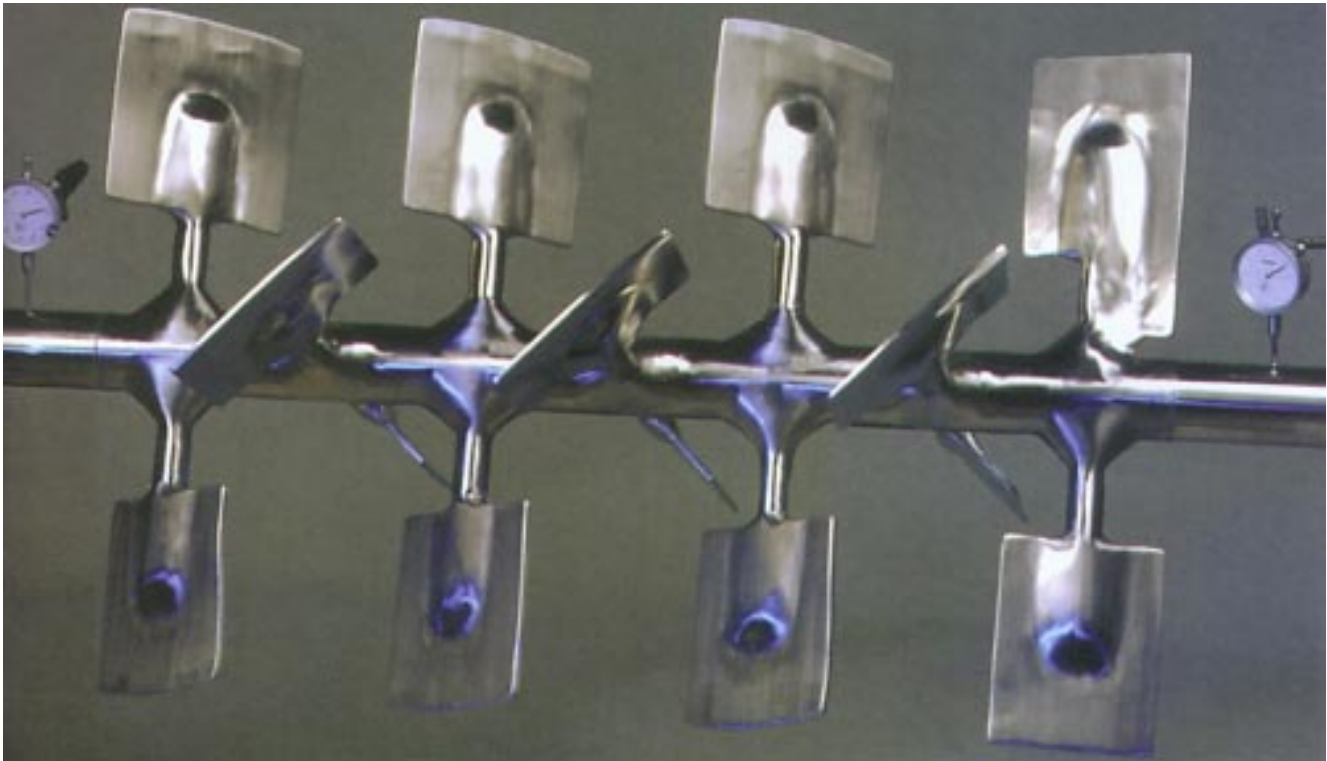

Patented Forberg Technology

- High mix efficiencies (1:1,000,000)
- Short mixing time
- Minimal product degradation
- Low rotor speeds
- Constant tip speed
- No shear
- Shear with optional high speed chopper
- Rapid mix cycles
- No heat generation
- Lowest cost per volume mixed
- Low power consumption
- Mass flow discharge
- Mechanical fluidization
- Organized and randomized transport system
- Exact scale-up
- No dead spots
- Weightless mixing

Standard APS Design Enhancements

- Solid agitator shafts lathed to ≤ 0.004 " total indicator runout to assure optimal sealing surfaces
- Precision liquid additions
- Split packing glands for easy removal and maintenance
- Sanitary or industrial designs
- Stub shaft assembly for rotor removal through the top
- Extruded gasket captured in a formed channel for a superior seal around bomb bay doors
- Dual pneumatic cylinders on each bomb bay door plus leveling and door adjusting bolts for a uniform seal



Optional Features

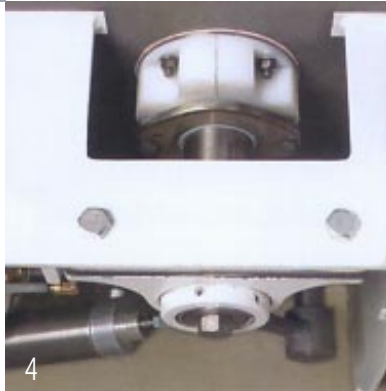
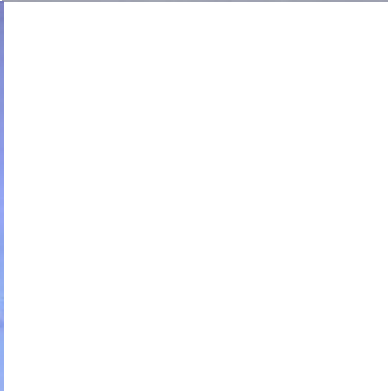
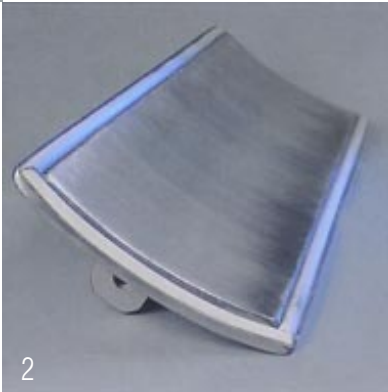
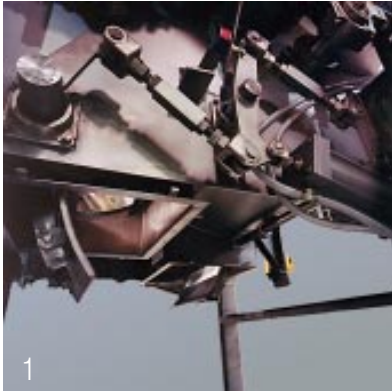

- High speed (1,700 or 3,600 rpm) choppers with choice of chopper heads for shear or de-agglomeration.
- Fluid coupling between motor and gearbox to allow for soft starts under load with 20-25% increased starting torque.
- Choice of discharge valves include half bomb bay doors, overtoggle bomb bay doors or spherical disc valves.
- Side access doors for additional entry to the mixer interior.
- Spray systems for liquid ingredients.
- Load cell systems
- Controls customized per application and demand
- USDA, FDA and USDA Dairy compliant

1. Two half bomb bay doors with over-toggle mechanical linkage.
2. Flush, radiused bomb bay door with solid extruded gasket.
3. Stub shaft solid bar paddle assembly.
4. Split packing gland and suspended bearing.
5. Dual pneumatic cylinders.
6. Explosion proof construction and controls.
7. Shaft seal purge controls and mixer electrical controls.



Standard blender sizes and approximate dimensions

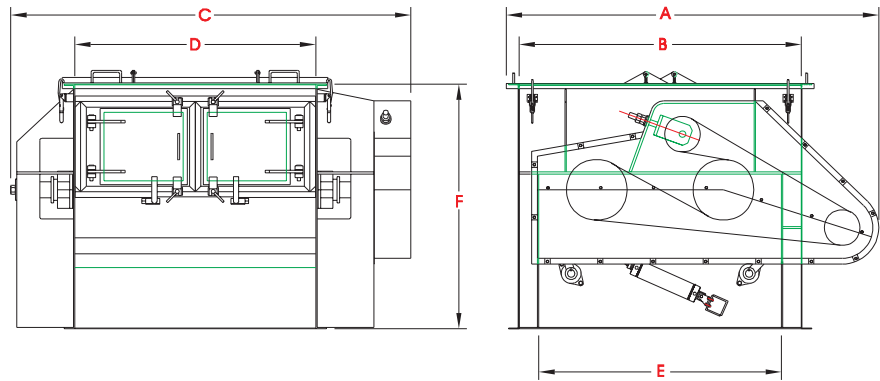

4/99 Printed in the USA. Subject to changes

Model	Capacity cubic feet/liters	HP (standard duty)	A	B	C	D	E	F
FZM-0.7	0.7/20	1 ½	-	18 ½	15 ½	-	16	19
FZM-2	3/60	3	37	27	22 ½	46	27	32
FZM-4	4/120	5	44	33	28 ½	53	33	32
FZM-7	7/200	5	52	39 ½	33 ½	60	39 ½	37 ½
FZM-12	12/350	5	60	49 ½	39 ½	65	49 ½	43 ½
FZM-18	18/500	7 ½	67	53	45 ½	76	53 ½	46 ½
FZM-26	26/750	15	78	61	52 ½	89	39 ½	58 ½
FZM-35	35/1,000	20	86	67	57	90	44	61 ½
FZM-53	53/1,500	30	100	77	66	103	46	68
FZM-70	70/2,000	40	109	86	73 ½	112	57	80 ½
FZM-88	88/2,500	40	117	91 ½	78	119	61	82 ½
FZM-125	125/3,600	50	*	106 ½	91 ½	*	63	94 ½
FZM-175	175/5,000	75	*	118	98 ½	*	79	98 ½

Air Process Systems & Conveyors Co., Inc.

774 Burr Oak Drive • Westmont, Illinois 60559

Phone: 630.887.0700 • 800.822.0771

Fax: 630.887.0771

Website: www.AirProcessSystems.com • E-mail: Sales@AirProcessSystems.com



AMERICAN PROCESS SYSTEMS

Member

Eirich Group

Ask about other equipment by American Process Systems & Eirich Machines:



Plow Blenders & Dryers



Ribbon & Paddle/Ribbon Blenders



Viscous Pumps



Bag Dump Work Stations