

COMMISSIONING INSTRUCTIONS

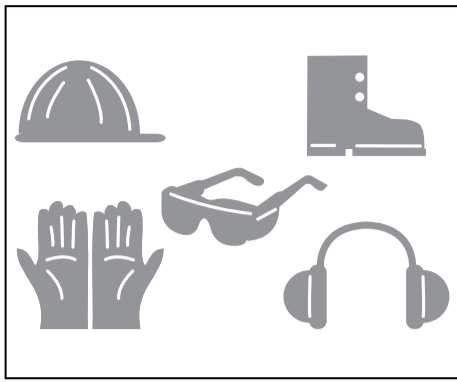

SAFETY EQUIPMENT & MANUAL HANDLING

Always wear the appropriate safety equipment. Safety boots, head protection, ear protection, eye protection and gloves.

Always ensure that you carry out a manual handling assessment prior to using the equipment.

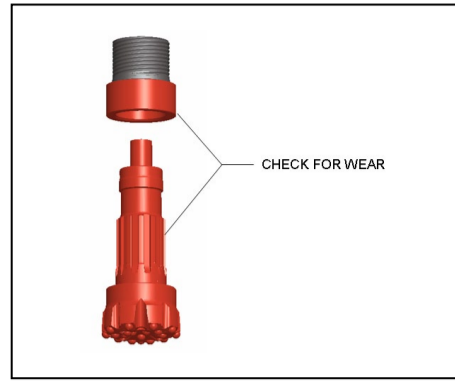

NEW HAMMER OR CHUCK WITH USED DRILL BIT

Check the drill bit splines for wear otherwise damage to the chuck could occur.



HAMMER EQUIPPED WITH SPLINE DRIVE PINS

Always ensure that a full set of servicable drive pins are fitted to these hammers before operating, otherwise damage to splines will occur. In these circumstances, warranty from the manufacturers will not apply.



IDENTIFICATION NUMBERS

- Keep a note of equipment serial numbers for future reference.
- Retain the certificate and spare parts list supplied with the hammer.

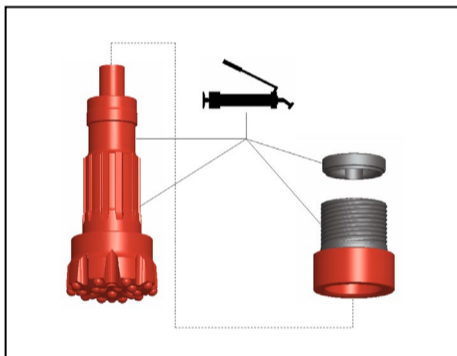

GREASE COMPONENTS

Grease all threads and splines when assembling the drill bit into the hammer.

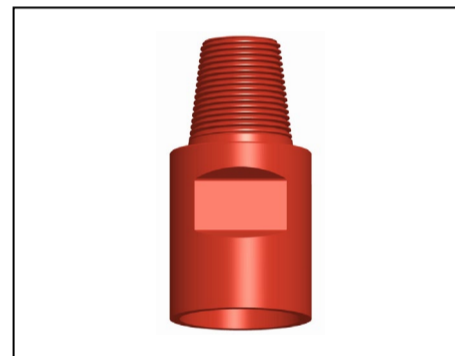

SUB ADAPTOR

A Sub Adaptor will be required if the hammer top thread differs to the drill tube thread.

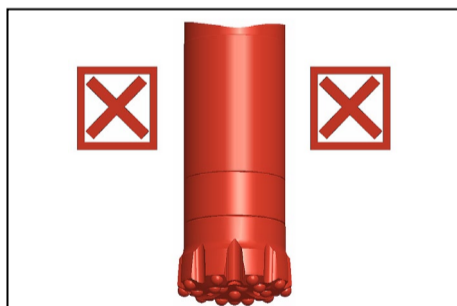

CHECK DRILL BIT DIAMETER

Never try to use a drill bit which is larger in diameter than a partially drilled hole.

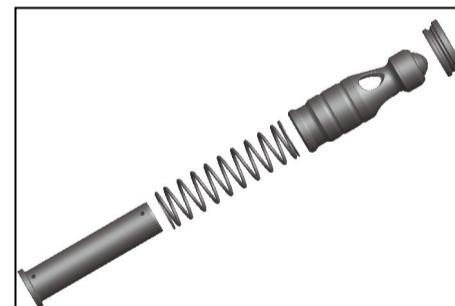

NON RETURN VALVE (N.R.V.)

You may remove the N.R.V. in dry conditions to give a slight increase in performance.



COMMISSIONING

- Ensure the hammer lubricator is working.
- Pour 1/2 pint (0.30 litres) of air line oil into the hammer.
- When attached to the drill rig, blow through with air to ensure all internal parts are lubricated.



BIT RETAINING RINGS

Never mix pairs of bit retaining rings. They are generally manufactured as matching pairs. Always re-fit them in the same position as when dismantled.