



BORDERTOWN RETAIL SYSTEMS, INC.

Increase profits and
Improved Efficiency, delivered to your door...



PRODUCT GUIDE

BORDERTOWN RETAIL SYSTEMS, INC.

PREMIUM SOLUTIONS FOR THE FURNITURE INDUSTRY, DELIVERED TO YOUR DOOR.

1 Year Warranty. Use our quality products with confidence, knowing we stand behind everything we sell.

Free Freight in the Continental USA and Canada. Call for details.

OUR MISSION:

Our Mission is to design and build displays that successfully market your product in today's competitive Retail Environment, increase your Sales, increase your Brand Recognition, and build customer loyalty.

See how our creative Team can improve your Retail Marketing!



CONTENTS

Tilted Top 3 tier Sofa Display	4
Tilted Top 2 tier Sofa Display	5
"Knockdown" Incline Top 3 Tier Sofa Display	6
Greenline 2 tier Sofa Display	7
Folding Display	8
Recliner Display	9
Desser Display	10
Mattress Trio Trolley	11
Mattress Spring Trolley	12
Mattress Pick Trolley	13
Adjustable Mattress Display	14
Incline Trolley	15
Incline Trolley	16
Sofa Dolly/Heavy Duty Multi-Purposed Trolley	17
Nesting Sofa Trolley	18
Sofa Trolley	19
Chair Bar	20
Sofa Suite Trolley	21
Headboard Display	22
Twin Mattress Display	23
5 – Rung Rug Display	24
Rug Displays	25
Rug Rack Divider - <i>Freestanding</i>	26
53" Tall Display Cabinet For Accessories	27
102" Tall Display Cabinet For Accessories	28
Ceiling Pendant Display Grid	29
Headboard Display For Accessories	30
Lamp Display Stands	31

TILTED TOP 3 TIER SOFA DISPLAY

Model #TT3TST

The TT3TST is an excellent way to triple your sales per square foot by displaying 3 sofas in the place of one. It offers better product viewing with its slightly tilted top tier, and provides consumers with more color and product options. This quality constructed display is very durable and yet extremely light weight for ease of handling. Their space saving design allows them to nest compactly together when not in use, conserving your much needed storage space.

- ▶ 45" W x 86" H
- ▶ 130 kg/ 286 lb weight capacity
- ▶ Requires no less than 9.5 ft ceiling
- ▶ Fully assembled
- ▶ Durable Baked Powder Coated Black Finish
- ▶ Caster options



TILTED TOP 2 TIER SOFA DISPLAY

Model #TT2TST

The TT2TST is an excellent way to increase your sales per square foot by providing shoppers more options using less space. It's consumer friendly design allows a shopper to comfortably try out the bottom sofa. The slightly tilted top tier allows better viewing of the product displayed. These light-weight displays come with a standard sign channel that allows you to insert your own attention grabbing sign. Their space saving design allows them to be nested together when not in use, making storage very convenient.

- ▶ 45" W x 60" H
- ▶ 24"x 45" sign holder
- ▶ 130 kg/286 lb weight capacity
- ▶ Requires no less than 8.5 ft ceiling
- ▶ Assembly required
- ▶ Durable Baked Powder Coated Black Finish



"KNOCK DOWN" INCLINE TOP 3 TIER SOFA DISPLAY

Model #KDTT3TST & Model #ADTT3TST

The KDTT3TST is a great way to triple your display area without adding any square footage to your showroom or warehouse. Increase your sales per square foot and at the same time offer consumers more color and style options. The KDTT3TST can be fully disassembled making it very useful for storing and setting up in areas with limited space. These durable displays come with a long lasting baked on finish, and have various settings for optional adjustable.

- ▶ 47" W x 86" H
- ▶ 130 kg/ 286 lb weight capacity
- ▶ Requires no less than 9.5 ft ceiling
- ▶ Assembly required
- ▶ Durable Baked Powder Coated Black Finish
- ▶ Model ADTT3TST adjusts every 3"

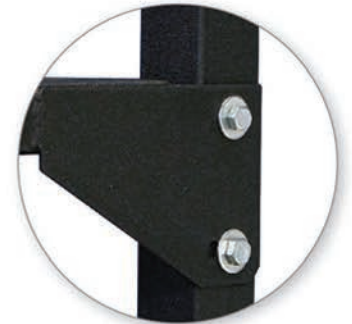

Adjustable Tiers



GREENLINE 2 TIER SOFA DISPLAY

Model #GL2T

Suitable for any budget, the GL2T is a great way to economically increase valuable showroom space. This compact display allows you to display sofas in no less than an eight foot ceiling height. It offers the shopper the option of trying out the bottom sofa. It ships in a small compact box and is very easy to assemble. This durable display comes with an environmentally friendly powder coated finish for longevity.

- ▶ 42" W x 62" H
- ▶ 64 kg/ 140 lb weight capacity
- ▶ Requires no less than 8 ft ceiling
- ▶ Assembly required
- ▶ Durable Baked Powder Coated Black Finish



FOLDING DISPLAY

Model #FSS

The FSS is a great way to show a sofa/loveseat combination with quick and efficient set up. These work great for sidewalk sales where set up can be done very quickly and effectively. This economically priced display has an outstanding weight capacity, and requires very little space for storage. It comes with a durable baked on powder coated finish for longevity.

- ▶ 51" W x 41" H
- ▶ 130 kg/ 286 lb weight capacity
- ▶ Requires no less than 7 ft ceiling
- ▶ Folding Design
- ▶ Durable Baked Powder Coated Black Finish



Model #RD4249

The RD4249 is a great way to display recliners, chairs and other types of furniture. Recliner displays are very efficient in using less showroom space, to display more fabric options and choices. These displays are very light weight and easy to handle with an outstanding weight capacity. Accepts all styles and sizes of recliners with its durable all metal top.

- ▶ 42" W x 32" D x 49" H
- ▶ 36" x 49" Height adjustment
- ▶ 130 kg/286 lb weight capacity
- ▶ Durable powder coated finish
- ▶ Full metal top



DRESSER DISPLAY

Model #DRT

These premium dresser displays are an innovative way to capture more of your valuable showroom space. The DRT display, with its very durable and solid design, is very lightweight for its outstanding weight capacity. Setup time is very quick and efficient with just four bolts to install, and allows for maximum adjustability with its strategically placed adjustment holes. The all metal top is very light weight yet durable with its seamless construction and baked on powder coated finish.

- ▶ 23" D x 69" W
- ▶ 33" to 66" height adjustment
- ▶ 225 lb weight capacity
- ▶ Easy adjustability
- ▶ Full metal top
- ▶ Durable baked powder coated black finish



Fully Adjustable



MATTRESS TRIO TROLLEY

Model #TT52

The TT52 is an extremely maneuverable trolley with its three wheeled ultra easy steer system. It is capable of skirting even the tightest of locations. These trolleys, with their tilted frames, are very multi-purpose and are excellent for handling headboards, bases, area rugs, appliances and much more. The TT52 fits conveniently through a standard 36" doorway, making it an effective tool for handling mattresses and furniture in institutions such as hotels, hospitals, and detention centers. Their unique space saving design allows them to be stacked up very effectively when not in use.

- ▶ 24" W x 60" L x 53" H
- ▶ 3.5" clearance
- ▶ 500 lb weight capacity
- ▶ Ultra easy steer system
- ▶ Durable baked on powder coated finish



MATTRESS SPRING TROLLEY

Model #MST4747

The MST4747 is an effective way to transport mattresses within the warehouse, showroom or for shipping. These units are very multi-purpose and can be used to handle many different items including rugs, chests, desks, headboards, and even dimensional material. With the ability to remove the sides, the MST4747 is easy to store and handle. Its durable powder coated finish and top quality casters, provides years of service..

- ▶ 54" W x 48" D x 48" H
- ▶ 47" inside dimensions
- ▶ Four - 4" casters, 2 w/brakes
- ▶ Durable baked on powder coated finish



MATTRESS DISPLAY RACK

Model #MDR

The MDR is a very efficient way to organize mattresses in the showroom or the warehouse. These high quality mattress displays are made of heavy gauge steel and have a durable powder coated finish. With no fasteners or tools required the set up is very quick and effective. This display can be used to store numerous other case goods such as head boards, mirrors, pictures and many other products.

- ▶ 96" L x 32" W x 46" H
- ▶ Holds five mattresses
- ▶ 14" compartments
- ▶ Easy setup and adjustability
- ▶ Durable baked on powder coated finish



ADJUSTABLE MATTRESS DISPLAY

Model #AMDR

This adjustable mattress display makes it possible to store up to six mattresses at one time. It is made to store queen and full mattresses. Each of the dividers are conveniently adjustable up to two inches. A box spring can be placed under the display for trying out the various mattresses on display. This durable display comes with the needed hardware and a quality finish.

- ▶ 60" D x 80" W x 104" H
- ▶ Six adjustable compartments
- ▶ Nine foot ceiling required
- ▶ Assembly required
- ▶ Durable finish



Six adjustable compartments



Model #IT3060

The IT3060 is an extremely effective product handling trolley designed for the furniture and appliance industry but is very multi-purpose for any industry. These heavy duty constructed products are manufactured domestically using high quality materials and completed with an environmentally preferred baked-on finish. The IT3060 with its accurately counter balanced design has been proven to significantly reduce workmen injury and product damage. These durable products have space saving features that allow them to be nested compactly together when not in use, making for efficient storage.

- ▶ 30" W x 60" H
- ▶ 12" long nose
- ▶ 8" solid wheels
- ▶ 500 lb capacity



INCLINE TROLLEY

Model #IT1854

The IT1854 is ideal for working in areas with limited space. This very effective product handling trolley is very multi-purpose for any industry. It has a well counter-balanced design that helps to alleviate workman injury and fatigue. Their size and spacesaving features allow them to be nested compactly together when not in use.

- ▶ 18" W x 54" H
- ▶ 12" long nose
- ▶ 8" solid wheels
- ▶ 400 lb capacity

Stackable for
Compact Storage



SOFA DOLLY / HEAVY DUTY MULTI-PURPOSE TROLLEY

SD3030, SDP4030, HDMPT

These all steel product handlers are very sturdy yet light weight and easy to handle. They work effectively with high quality casters, and make a very efficient and maneuverable handling device. The all powder coated baked on finish makes these movers a great choice for durability and the environment. All products are domestically made with top quality materials.

Model #SD3030

- ▶ 30" L x 30" W x 5" H
- ▶ Four 3" casters, no/brake
- ▶ No handle
- ▶ Powder coated red
- ▶ 500 lb capacity



Model #SDP4030

- ▶ 40" L x 30" W x 40" H
- ▶ Four 3" casters, no/brakes
- ▶ Powder coated red
- ▶ 500 lb capacity



Model #HDMPT

- ▶ 60" L x 30" W x 48" H
- ▶ Four 4" casters, 2 w/brake
- ▶ Powder coated black
- ▶ 1500 lb capacity



NESTING SOFA TROLLEY

Model #NST

The NST is a very maneuverable tool that has the ability to maneuver around even the tightest, most difficult corners without any problems. With its slim design it is able to fit tight against a wall, and works very well for tent or sidewalk sales. It can be easily wheeled around indoors or outdoors. These units are able to effectively fit any sofas, loveseats, or chairs up to 84" long, and nest compactly together for space saving characteristics when not in use. Its durable finish along with high quality casters, gives this unit years of trouble free service.

- ▶ 49.5" H x 88" L x 21.5" W
- ▶ Four 4" casters
- ▶ Elegant two level
- ▶ Durable baked on powder coated finish



Stackable for
Compact Storage



Model # 3TST & 2TST

These trolleys are a very efficient way to handle two or three sofas at one time. They work very well for displaying sofas for tent sales and for moving sofas into and around warehouse and showroom. The trolley comes with four quality heavy duty casters for ease of moving. Reduce handling time and effort while improving re-organization efforts.

3TST

- ▶ 82" H x 42" D x 47" W
- ▶ Four 4" casters, 2/w brakes
- ▶ Heavy duty construction
- ▶ Easy to maneuver
- ▶ Powder coated finish



2TST

- ▶ 49.5" H x 42" D x 47" W
- ▶ Four 4" casters, 2/w brakes
- ▶ Heavy duty construction
- ▶ Easy to maneuver
- ▶ Powder coated finish



CHAIR BAR

Model #CBR

The Chair Bar is an excellent way to effectively display a chair on any TT2TST or TT3TST.

With no fasteners, clamps, or drilling required, the chair bar is very easy to install on any new or existing displays.

Provide customers with more product package options, using less of your valuable showroom floor space.

- ▶ More selection, more sales
- ▶ One size fits all
- ▶ Freight friendly shipping
- ▶ E-Z setup, no fasteners
- ▶ Durable baked on finish
- ▶ Made in the USA

Unit Price: Call

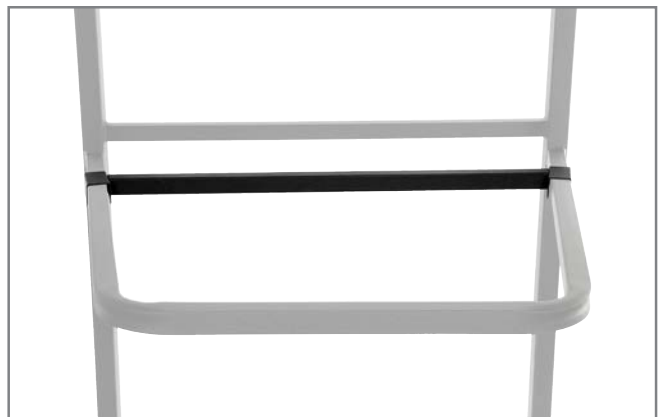

BORDER TOWN

Model #SST, ESST, HYBRID

These lightweight and easy to handle trolleys have robust cantilever design allowing much easier loading and unloading of sofas and other upholstery products. Significantly reduce workman injury and product damage with the use of these safety designed items. Space saving design saves your space not only on your floor, but also in their ability to nest compactly together when empty. The trolleys work great for furniture retailers, manufacturers, and freight logistics.

Model #SST

- ▶ 49" H x 82" L x 30/21" D
- ▶ Four 4" casters, 2 w/brakes
- ▶ Durable construction
- ▶ Powder coated finish



Model #EEST

- ▶ 59" H x 82" L x 30/21" D
- ▶ Four 4" casters, 2 w/brakes
- ▶ Consumer friendly design
- ▶ Can sit on bottom sofa
- ▶ Powder coated finish



Model #HYBRID

- ▶ 49" H x 102" L x 23/21" D
- ▶ Four 4" casters, 2 w/brakes
- ▶ Durable construction
- ▶ Powder coated finish



HEADBOARD DISPLAY

Model # HBD3T

Effectively provide your customers with an assorted amount of headboard choices with this stable three tier headboard display.

This durable display uses limited space to efficiently market your headboards. Give your store the competitive edge.

- ▶ More selection, More sales!
- ▶ One size fits all
- ▶ Freight friendly shipping
- ▶ Durable baked on finish
- ▶ Made in the USA
- ▶ Optional bolting headboard kit
- ▶ Optional hooking headboard kit

Unit Price

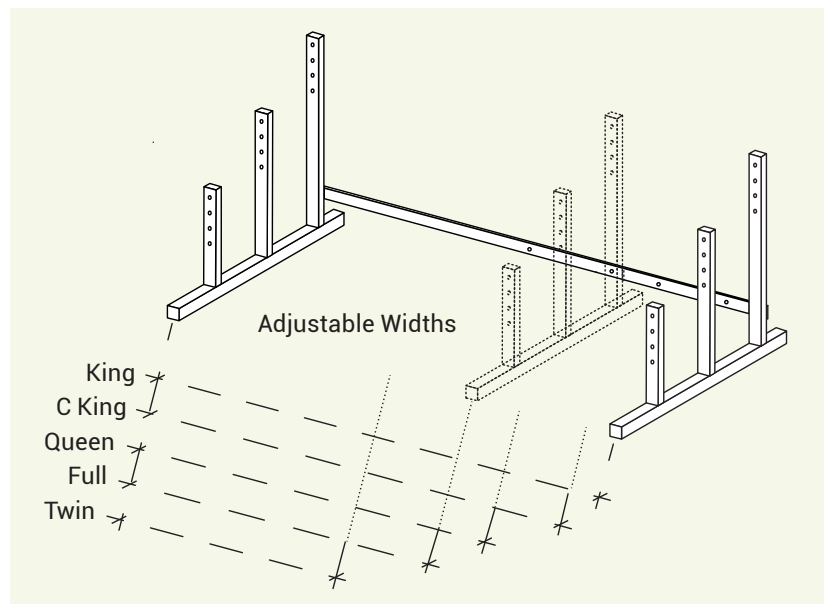

TWIN MATTRESS DISPLAY

Model # TMD4870

Effectively provide your customers with an assorted amount of mattress choices with this stable and adjustable twin mattress display.

This durable display gives you the adjustability needed to efficiently display your mattresses using limited showroom space.

- ▶ More selection, More sales!
- ▶ Three size adjustability
- ▶ KD freight friendly shipping
- ▶ Durable baked on finish
- ▶ Made in the USA
- ▶ Hardware included
- ▶ Optional caster and security kit

Unit Price: Call

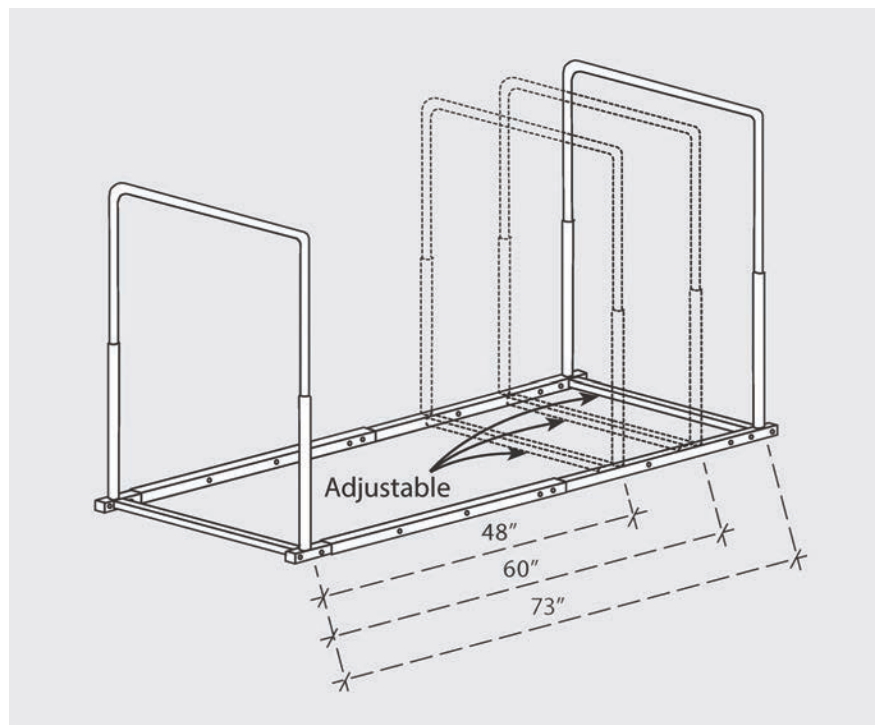

5 – RUNG RUG DISPLAY

Model #5RRD106 & #5RRD106-FS

FS This Rug Display is a great way to attractively display 3 large Rugs. It easy for the Shopper to view and feel the Rugs, and make a selection!

- ▶ Dimensions: 10' tall x 6' wide; 2.5' between rungs
- ▶ Includes 2 wall-mount Brackets
- ▶ Powder coated black

Unit Price



Our Rug Displays will attractively present your Rugs at retail, and draw Shoppers to choose you brand! The 20-Arm and the 10-Arm give you two options to choose from, depending on your space.

20-Arm Rug Display

- ▶ Displays up to (40) 5' x 8' Rugs
- ▶ Easy-swing Arms let the Shopper conveniently browse the Rug selection
- ▶ Heavy-duty steel construction

10-Arm Rug Display

- ▶ Displays up to (20) 5' x 8' Rugs
- ▶ Easy-swing Arms let the Shopper conveniently browse the Rug selection
- ▶ Heavy-duty steel construction



RUG RACK DIVIDER - *FREESTANDING*

Model #030716-H

- ▶ Dimensions: 61" wide with 24" wide Feet for stability
- ▶ Adjustable height, up to 94" tall
- ▶ 4 Floor Levelers
- ▶ One top Cross Bar with two double hanger bars
- ▶ Includes 8 Rug Holder Clips
- ▶ Powder coated black



53" Tall DISPLAY CABINET FOR ACCESSORIES

Model #100-47

This attractive white display cabinet will create a premium and engaging retail presentation for your entire line of accessories.

The quality of our finish and construction will give your retailer a display they will proud to use, and will connect shoppers to the Ashley brand!

- ▶ Dimensions: 48" wide x 24" deep; 53 $\frac{7}{8}$ " tall
- ▶ 3.5" toe kick area and 3.5" valance area
- ▶ Quality white melamine construction
- ▶ One piece melamine back for long lasting durability•Two adjustable shelves
- ▶ 48" wide Cabinet is divided into two 23" wide display areas, with a Center Vertical Divider Panel
- ▶ We can ship competitively to retailers in the entire USA and Canada from our centrally located ND factory.



102" TALL DISPLAY CABINET FOR ACCESSORIES

Model #100-48A

This attractive white display cabinet will create a premium and engaging retail presentation for your entire line of accessories.

The quality of our finish and construction will give your retailer a display they will proud to use, and will connect shoppers to the Ashley brand!

- ▶ Dimensions: 48" wide x 24" deep; 102" tall
- ▶ 3.5" toe kick area and 3.5" valance area
- ▶ Quality white melamine construction
- ▶ One piece melamine back for long lasting durability
- ▶ Six adjustable shelves
- ▶ 48" wide Cabinet is divided into two 23" wide display areas, with a Center Vertical Divider Panel
- ▶ We can ship competitively to retailers in the entire USA and Canada from our centrally located ND factory.



CEILING PENDANT DISPLAY GRID

Model #CPG4848

This Display Grid is an attractive & easy way to hang up your Accessories, for retail display!

- ▶ Dimensions: 48" long x 48" wide
- ▶ Powder coated white
- ▶ Packaged 1 Display Grid per carton

PRICE:



1 Display Grid shown hanging from the ceiling



HEADBOARD DISPLAY FOR ACCESSORIES

Model #100-43

This attractive white display cabinet will create a premium and engaging retail presentation for your entire line of accessories

The quality of our finish and construction will give your retailer a display they will be proud to use, and will be proud to use, and will connect shoppers to the Ashley brand!

- ▶ Dimensions: 59 7/8" wide x 14 3/4" deep; 46 3/8" tall
- ▶ Display area: 58 3/8" wide x 17 " tall
- ▶ White 5/8" melamine construction
- ▶ White Edging, for a quality finish and appearance
- ▶ Removable legs
- ▶ Wrapped in foam and palletized, for safe shipping



LAMP DISPLAY STANDS

These attractive white displays will create a premium and engaging retail presentation for your lamps and accessories.

The quality for our finish and construction will give your Retailer a display they are proud to use, and will connect shoppers to the Ashley brand!

- ▶ Available in 3 heights
- ▶ White melamine 1-piece construction

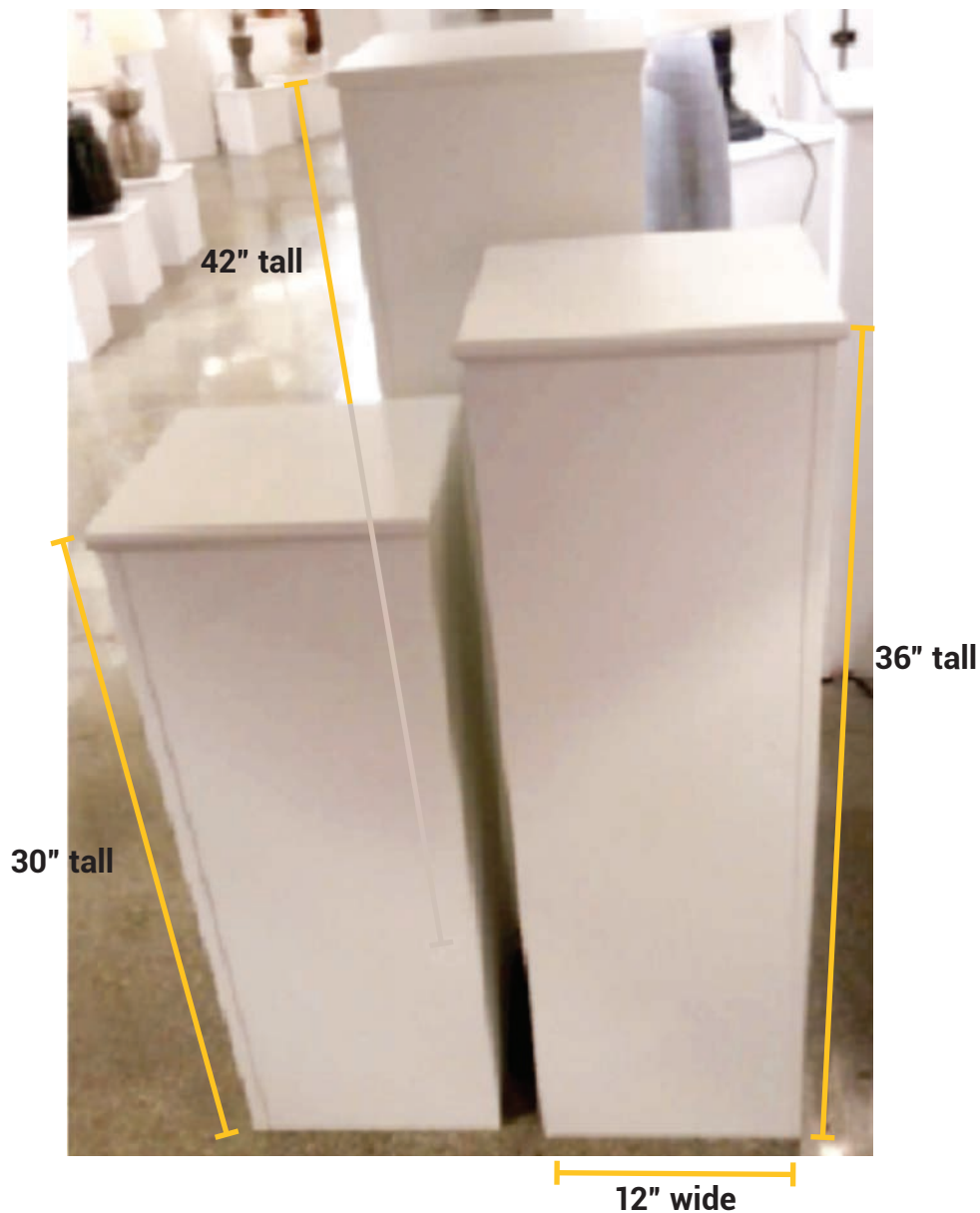



Minneapolis Sales Office and Showroom

TF: 800-263-1338

F: 701-886-7628

E: arc-waysales@bordertownwire.com

14250 Judicial Road

Minneapolis, MN 55306

Factory Location

TF: 800-263-1338

F: 701-886-7628

E: arc-waysales@bordertownwire.com

118 1st Street

Neché, ND 58265