

# DS-520

Water-Resistant Weighing Scale



- **Large Customer Display**
  - Large figures LCD display
- **Stainless Steel Design**
  - Sanitary Stainless Steel Platter makes cleanup easy.
- **User Friendly Feature**
  - Auto power-off function saves battery energy.
- **Water tight Construction**
  - Waterproof scale works anywhere corrosion proof .
- **Chemical resistant and PU coated wash-down load cell**
- **NEMA 4X Enclosure IP-65**

New Brunswick International, Inc.  
DIGI Retail Scale and Labeling Systems



Large Display

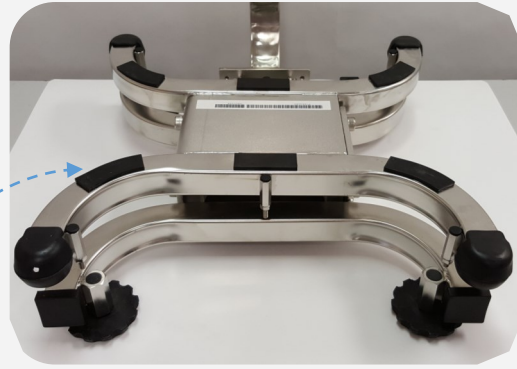

Unique design ensures impact protection of the load cell

Water Sealed Platform/ IP65 Specifications

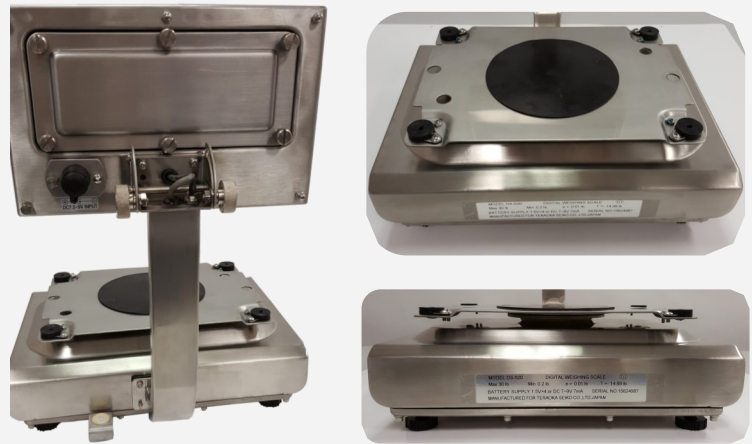

Specifications

General	Power source	Battery (4 C size dry batteries) or (Optional AC Adapter)	
	Construction	Stainless Steel	
	Operation humidity	15% - 85% RH Non-Condensation	
	Operating Temperature	14 to 104 degrees F	
	Operator Display	LCD 5 digits (Weight)	
		Portion Control	Floor Scale
		30 lb.	300 lb.
Capacity	30lb	300lb	
Weighing Interval	Single x 0.01	Single x 0.10	
Dimensions	Platter Dimensions	13.5"(W) x 9.5"(D) x 3.5"(H)	16"(W) x 16"(D) x 4"(H)
	Overall Dimensions	13.5"(W) x 12"(D) x 17"(H)	16"(W) x 16"(D) x 35.5"(H)

Scale Dimensions (30 lb)

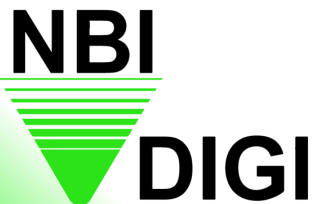
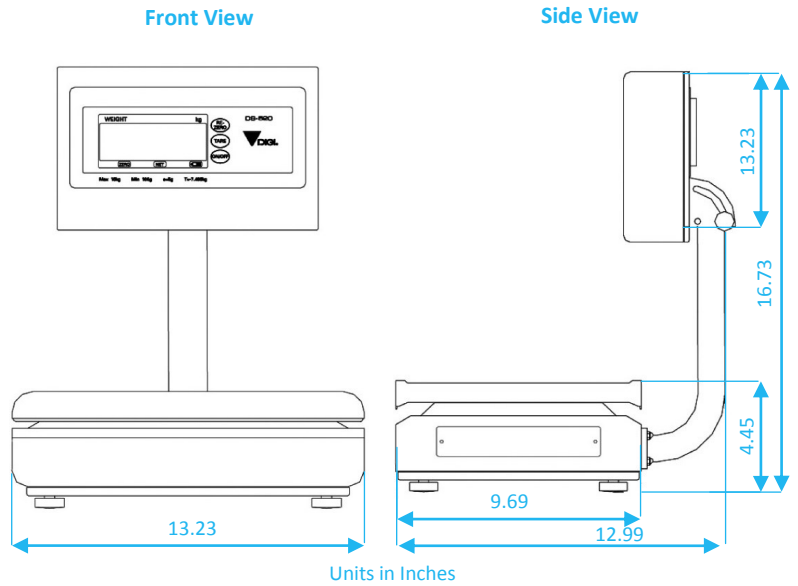

New Brunswick International, Inc.

Corporate Headquarters  
76 Veronica Ave  
Somerset, NJ 08873  
TEL: (732) 828-3633  
FAX: (732) 828-4884

West Coast Office  
530 West Central Ave. Suite C  
Brea, CA 92821  
TEL: (714) 671-7911  
Fax: (714) 671-0798

www.nbidigi.com

