

Pulsar 4 Electronic Trouble Shooting Guide

General Overview

The purpose of this guide is to familiarize installation and maintenance personnel with the electrical functions of the Pulsar IV and to assist in the "troubleshooting" of any electrical failures that may occur.

The Pulsar IV incorporates six electrical components and their associated wiring. Each component is critical in the safe operation and dispensing of the chlorinated solution.

Transformer:

The electrical system operates from a 24 Volt AC source provided by a U.L.-listed class-II energy-limiting step-down transformer. The transformer's primary coil (the side connected to the 120 Volt source) is designed to "open like a fuse" when the transformer's VA (Volt Amp.) rating is exceeded.

When the primary coil opens the 24 Volt source is removed from the secondary electrical components, preventing over-heating of components, wiring and possible electrical shock hazard.

Junction Box:

The transformer, Lid Shut-off Switch, Electronic Overflow Switch and Solenoid/Timer Assembly are wired to the junction box terminal strip (Fig. 1 & 2). A relay is mounted in the junction box to remove the 24 Volt supply from the Solenoid/Timer Assembly if the chlorinator lid is removed or if the chlorinator tank overfills.

Lid Shut-off Switch:

When the chlorinator lid is opened the Lid Shut-off Switch energizes the junction box relay which removes the 24 Volt source from the Solenoid/Timer assembly and causes the water solenoid valve to close (refer to manual for picture).

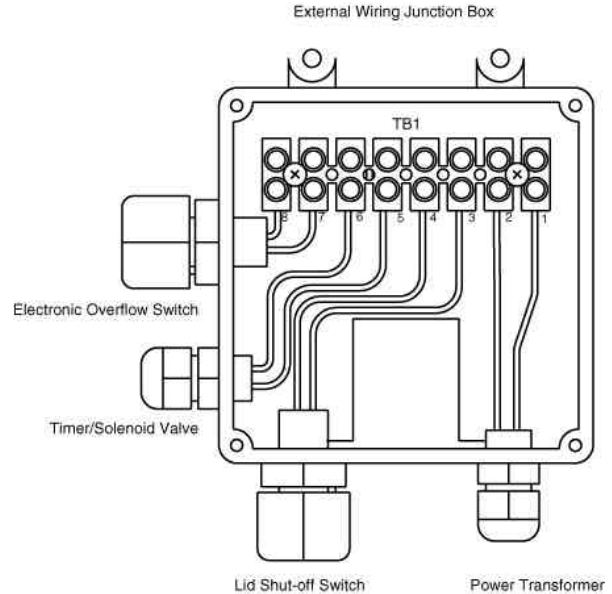

Figure 1 Junction box terminal strip

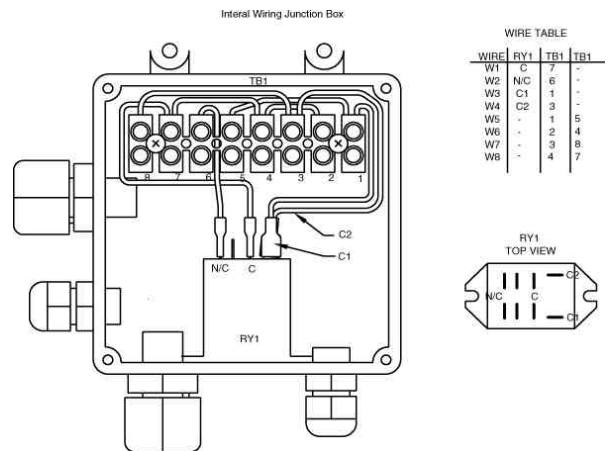

Figure 2 External wiring Junction Box Terminal Strip

Electronic Overflow Switch:

When the water level reaches a pre-determined height in the chlorinator tank the Electronic Overflow Switch energizes the junction box relay removing the 24 Volt source from the Solenoid/Timer Assembly which causes the water solenoid valve to close (refer to manual for picture).

Solenoid/Timer Assembly:

The Solenoid/Timer Assembly consists of the timer module which is plugged into the solenoid actuated water valve.

Timer Module: The timer module (Fig. 4) turns on and off the water solenoid valve at an adjustable on/off cycle to maintain a balance between the inlet water and the discharged chlorine solution. The timer has two controls -- one to adjust the **ON** time to: 11 seconds = Normal, 22 seconds = Low, and 30 seconds = Hi; and the second to adjust the **DELAY** time in seconds (i.e., A = 19 secs to G = 53 minutes).

WARNING: While turning the upper and lower timer knobs, **DO NOT FORCE** the knob beyond their stop points. Doing so will cause damage to the controls.

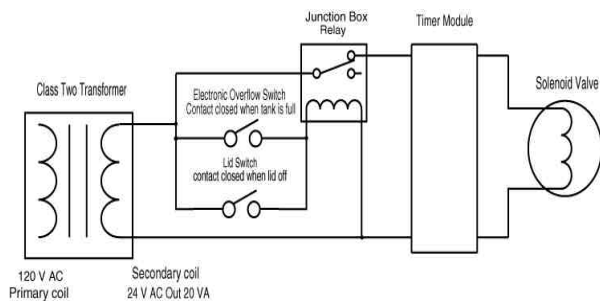

Figure 3 Simple schematic

Timer Settings:

Top Knob (off time)	Bottom Knob (on time)
A – 19 seconds	High – 30 seconds
B – 3.2 minutes	Low – 22 seconds
C – 14.0 minutes	Normal – 11 seconds
D – 27.0 minutes	
E – 39.0 minutes	
F – 50.0 minutes	
G – 53.0 minutes	

Examples of on time calculation:

Example #1:

Top Knob (off time) set to "A" and Bottom Knob (on time) set to "HIGH"

$$\text{Total cycle time} = A \text{ (19 seconds "off time")} + \text{HIGH (30 seconds "on time")} = 49 \text{ seconds}$$

$$\% \text{ on time} = \frac{\text{on time}}{\text{Total cycle time}} \times 100 \text{ or } \frac{30}{49}$$

$$= 61.2\% \text{ on time}$$

Example #2:

Top Knob set to "B" and Bottom Knob set to "LOW"

$$\text{Total cycle time} = B \text{ (192 seconds "off time")} + \text{LOW (22 seconds "on time")} = 214 \text{ seconds}$$

$$\% \text{ on time} = \frac{\text{on time}}{\text{Total cycle time}} \times 100 \text{ or } \frac{22}{214}$$

$$= 10.28\% \text{ on time}$$

Water Solenoid Valve: When the 24 Volt source is applied from the timer module to the solenoid coil of the water valve a magnetic core retracts into the solenoid coil allowing water to flow through the valve and into the chlorinator tank.

Troubleshooting Guide

Step-by-step Electrical System Test

1. Close water inlet and outlet valves
2. Verify that the Power transformer is plugged into a wall receptacle that has been tested to verify that power is present. Verify timer module power light is on (see Fig. 4).

If power is on go to next step, if not meter test.

3. Lift the hopper off the base -- does the power light go out?

If light goes out replace the hopper on it's base and go to next step, if not go to the meter test.

4. Lift hopper lid with your hand. Did the power light go out?

If yes, then press the lid switch down and hold, did the light come on?

If yes then while depressing the lid switch reach under the deflection plate and lift the electronic overflow switch, did the light go out?

If yes, then the lid and electronic overflow switches are functioning properly and the 24 Volt power source is applied to the timer module. Go to the next step.

If not go to the Meter Test.

READ THE FOLLOWING INSTRUCTION STEPS BEFORE CONTINUING THE TEST. THE TIMER MODULE MAY BE DAMAGED IF NOT PERFORMED CORRECTLY.

5. Turn the upper timer module control knob fully clockwise and counter-clockwise to verify that the knob comes to a stop at each end of the rotation. Be careful not to force the knob beyond the stop. If the knob rotates fully then the control knob is broken and the timer module must be replaced.

Perform this test on the lower control knob. Again **DO NOT FORCE** the knob.

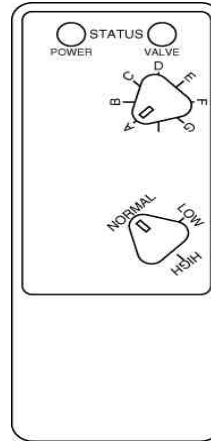

Figure 4

Replace the timer if defective and go to the next step.

6. Set the upper control knob to the "A" (19 seconds solenoid on time) position and the lower control knob to the "normal" (11 seconds solenoid off time) position. Verify that the timer module power light is on. Watch the valve light. It should come on for 11 seconds and off for an 19 seconds. During this test the solenoid valve will click at the start and end of the duty cycle and may hum while the valve light is on. This verifies that the solenoid coil is not defective. If the solenoid valve does not click on then vibrate during the on portion of the duty cycle the solenoid coil of the solenoid water valve must be replaced. If the light cycles on and off, go to the next step. If not the timer module is defective and must be replaced.

7. Turn both the inlet and outlet water valves on to verify that water is available and watch for water flow. When the timer module valve light is on and the solenoid coil is vibrating the water should begin to flow. When the timer module light is off the solenoid coil should stop vibrating and the water should stop flowing. If the valve comes on and off then the electrical system is performing correctly. If the water fails to start or stop flowing then the valve portion of the solenoid water valve is defective and must be replaced or repaired.

Restore the timer modules upper and lower control knobs to their previous times or refer to the owners manual for instruction.

METER TEST

The following tests should be performed utilizing a volt meter (ref. Fig.5 – detailed schematic & Fig.6 -- meter placement). The following test is performed using a volt meter set on AC Voltage with a voltage scale set greater than 24 Volts. The lid of the hopper should be closed and on its base and the electronic overflow switch should not be in the up position.

Connect the meter leads to the terminal board (TB1) as instructed in the following steps (see Fig. 6).

1. Connect the meter test leads to terminals 1 and 2 of the TB1. The meter should indicate 24 volts. If the reading is correct go to next step.

If no voltage is present, check the wiring to the power transformer and verify that power is present at the outlet that the transformer is plugged into. If the wiring is correct and the outlet power is verified then the transformer is defective and must be replaced.

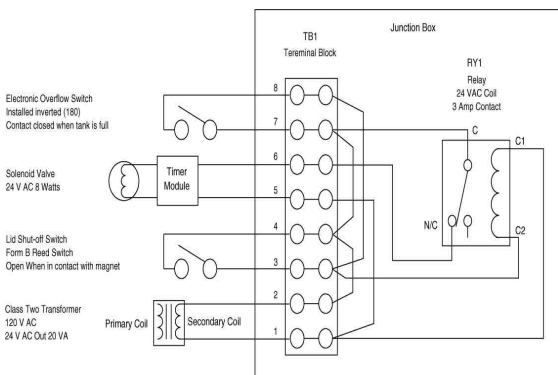

Figure 6

2. Connect the meter test leads to terminals 1 and 3 of TB1. No voltage should be present.

While observing the meter, lift the lid of the hopper. The meter should read 24 volts and return to zero when the lid is replaced.

Lift the hopper off its base. The meter should indicate 24 volts and return to zero when the base is replaced.

Lift the hopper lid and press down the lid switch. Reach under the deflection plate and lift the

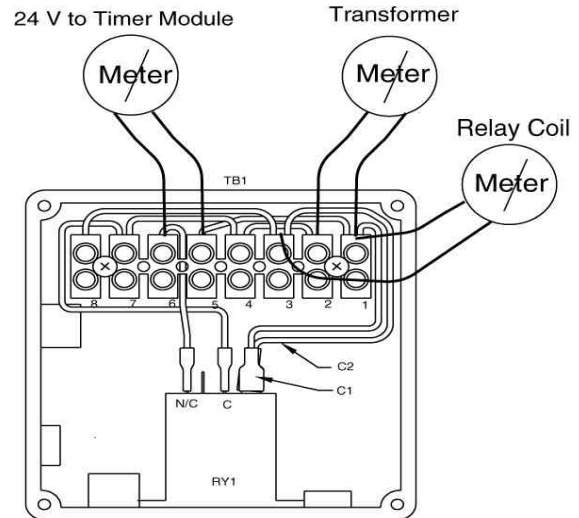

Figure 5

electronic overflow switch. The meter should indicate 24 volts with switch in the up position and return to zero when released.

During the next test, remove power to the junction box between each step by unplugging the transformer from the power outlet. Once the wire is removed from the terminal strip and is isolated, restore power to the junction box and perform the test.

If 24 volts is always present during the above tests the hopper lid switch and/or the electronic overflow switch may be defective and must be disconnected from the terminal strip TB1 one at a time. Refer to Fig. 1 and disconnect the wire to terminal 3 of TB1. Observe the meter. The 24 volts may or may not return to zero. If the voltage returns to zero then the lid switch is defective and must be replaced. If the 24 volts remain with terminal 3 disconnected leave the wire to terminal 3 disconnected and perform the same test with the electronic overflow switch. Disconnect the wire to terminal 7. Again the 24 volts should return to zero. If not the electronic over flow switch is defective or is stuck in the up position. Remove power to the Junction box and reconnect the wires to terminal 3 and 7.

3. Connect the meter test leads to terminals 5 and 6. If 24 volts is present, but the power light on the timer module is off, then the timer module or its wiring is defective. If 24 volts are not present then the relay RY1 is defective and must be replaced.