

STA-RITE®

“CFA” SERIES BRONZE PUMP WITH 5” INTEGRAL TRAP SELF-PRIMING

O W N E R ' S M A N U A L

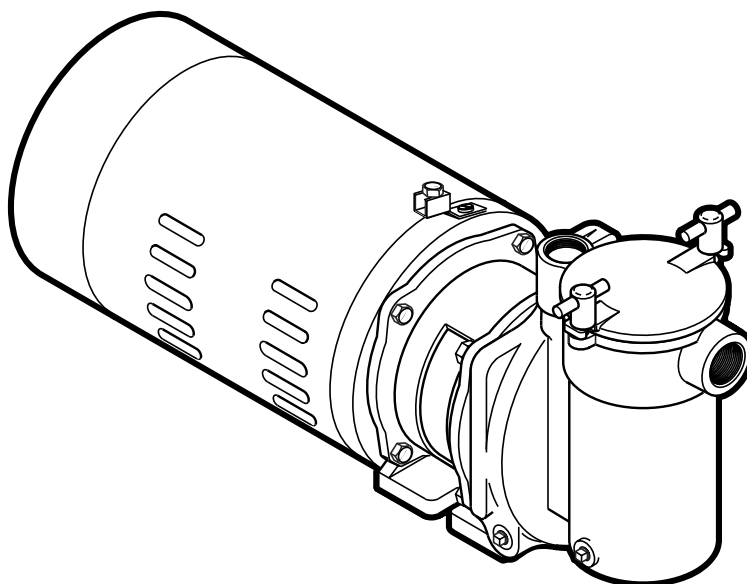

INSTALLATION, OPERATION & PARTS

MODELS

3/4 HP
CFAD-75DL

1 HP
CFAE-79DL
CFAE3-79D

1-1/2 HP
CFAF-80DL

2 HP
CFAEG-81DL

2-1/2 HP
CFAAEG-82DL

This manual should be furnished to the end user of this pump; its use will reduce service calls and chance of injury and will lengthen pump life.

Sta-Rite Pool/Spa Group

293 Wright Street, Delavan, WI 53115

North America: 800-752-0183, FAX 800-582-2217

International: 262-728-5551, FAX: 262-728-4461, TELEX: ITT 4970245

www.sta-ritepool.com

Union City, TN • Delavan, WI • Mississauga, Ont. • Murrieta, CA

© 2003, Sta-Rite Industries, Inc. Printed in U.S.A.

S986 (Rev. 3/11/03)

IMPORTANT SAFETY INSTRUCTIONS

Always follow basic safety precautions with this equipment, including the following.

▲ WARNING To reduce the risk of injury, do not permit children to use this product unless they are closely supervised at all times.

▲ CAUTION This pump is for use with permanently installed pools and may also be used with hot tubs and spas if so marked. Do not use with storable pools. A permanently installed pool is constructed in or on the ground or in a building such that it cannot be readily disassembled for storage. A storable pool is constructed so that it may be readily disassembled for storage and reassembled to its original integrity.

SAVE THESE INSTRUCTIONS

'CFA' SERIES PUMP WITH TRAP

To avoid unneeded service calls, prevent possible injuries, and get the most out of your pump, READ THIS MANUAL CAREFULLY!

The Sta-Rite 'CFA' Series Self-Priming Centrifugal Pump:

- Is designed for use with swimming pools or as a centrifugal pump.
- Is an excellent performer; durable, reliable.

Table of Contents

Safety Instructions	2
Installation	3-4
Electrical	4-5
Operation	6
Storage/Winterizing	6-7
Pump Service	7-8
Troubleshooting Guide	9
Repair Parts List	10
Warranty	12

READ AND FOLLOW SAFETY INSTRUCTIONS!

▲ This is the safety alert symbol. When you see this symbol on your system or in this manual, look for one of the following signal words and be alert to the potential for personal injury.

▲ DANGER warns about hazards that **will** cause death, serious personal injury, or major property damage if ignored.

▲ WARNING warns about hazards that **can** cause death, serious personal injury, or major property damage if ignored.

▲ CAUTION warns about hazards that **will** or **can** cause minor personal injury or property damage if ignored.

NOTICE indicates special instructions not related to hazards.

Carefully read and follow all safety instructions in this manual and on equipment. Keep safety labels in good condition; replace if missing or damaged.

▲ WARNING **Hazardous pressure** **Incorrectly installed or tested equipment may fail, causing severe injury or property damage.** Read and follow instructions in owner's manual when installing and operating equipment. Have a trained pool professional perform all pressure tests.

1. Do not connect system to a high pressure or city water system.
2. Use equipment only in a pool or spa installation.
3. Trapped air in system can cause explosion. BE SURE all air is out of system before operating or testing equipment.

Before pressure testing, make the following safety checks:

- Check all clamps, bolts, lids, and system accessories before testing.
- Release all air in system before testing.
- Tighten Sta-Rite trap lids to 30 ft. lbs. (4.1 kg-m) torque for testing.
- Water pressure for test must be less than 25 PSI (7.5 kg/cm²).
- Water Temperature for test must be less than 100° F. (38° C).
- Limit test to 24 hours. After test, visually check system to be sure it is ready for operation. Remove trap lid and retighten hand tight only.

NOTICE: These parameters apply to Sta-Rite equipment only. For non-Sta-Rite equipment, consult manufacturer.

CAUTION Risk of strains or crush injuries from lifting pump. Pump is heavy; when lifting or moving pump, take all proper precautions for the weights involved.

INSTALLATION

Only qualified, licensed personnel should install pump and wiring.

Pump mount must:

Be located away from corrosive or flammable liquids.

Have enough ventilation to maintain air temperature at less than the maximum ambient temperature rating (Max. Amb.) listed on the motor model plate. If this pump is in-

stalled in an enclosure/pump house, the enclosure must have adequate ventilation and air circulation to keep the temperature in the enclosure at or below the motor's rated ambient temperature whenever the pump is running.

- Be solid - level - rigid - vibration free. (To reduce vibration and pipe stress, bolt pump to mount).
- Allow pump suction inlet height to be as close to water level as possible.
- Allow use of short, direction suction pipe (to reduce friction losses).
- Allow for gate valves in suction and discharge piping.
- Have adequate floor drainage to prevent flooding.
- Be protected from excess moisture.
- Allow adequate access for servicing pump and piping.
- **NOTICE: Support all piping connected with pump!**

WARNING Fire and burn hazard. Modern motors run at high temperatures. To reduce the risk of fire, do not allow leaves, debris, or foreign matter to collect around the pump motor. To avoid burns when handling the motor, let it cool for 20 minutes before trying to work on it.

Pool Pump Suction Requirements

WARNING Pump suction is hazardous and can trap and drown or disembowel bathers. Do not use or operate swimming pools, spas, or hot tubs if a suction outlet cover is missing, broken, or loose. Follow the guidelines below for a pump installation which minimizes risk to users of pools, spas, and hot tubs.

Entrapment Protection

The pump suction system *must* provide protection against the hazard of suction entrapment or hair entrapment/entanglement.

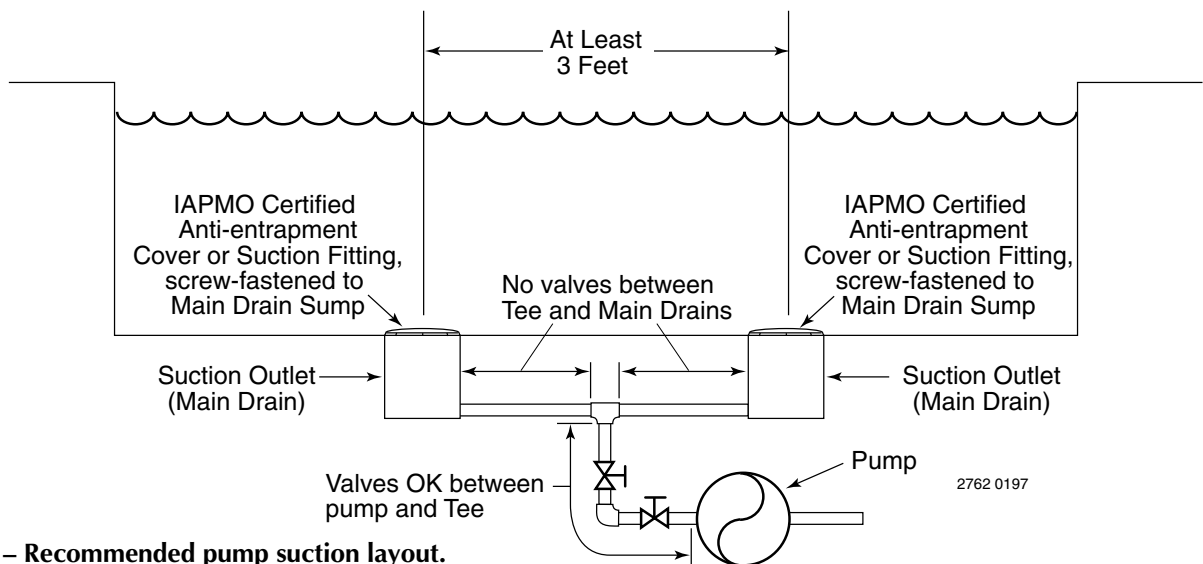

Figure 1 – Recommended pump suction layout.

Suction Outlet Covers

All suction outlet covers must be maintained. They must be replaced if cracked, broken, or missing.

See below for outlet cover certification requirements.

All suction outlets must have correctly installed, screw-fastened covers in place.

Testing and Certification

Suction outlet covers must have been tested by a nationally recognized testing laboratory and found to comply with the latest ASME/ANSI Specification for *Suction Fittings For Use in Swimming Pools, Spas, Hot Tubs, and Whirlpool Bathtub Applications*.

Outlets Per Pump

Provide at least two hydraulically balanced main drains, with covers (see Page 3), for each swimming pool pump suction line. The centers of the main drains (suction fittings) must be at least three feet apart.

The system must be built so that it cannot operate with the pump drawing water from only *one* main drain (that is, there must be at least two main drains connected to the pump whenever it is running). (See Figure 1). However, if two main drains run into a single suction line, the single suction line may be equipped with a valve which will shutoff *both* main drains from the pump (see Figure 1).

More than one pump can be connected to a single suction line as long as the requirements above are met.

Water Velocity

The maximum water velocity through any suction outlet must be 1.5 feet per second unless the outlet complies with the latest ASME/ANSI Specification for *Suction Fittings For Use in Swimming Pools, Spas, Hot Tubs, and Whirlpool Bathtub Applications*. In any case, do not exceed the suction fittings maximum designed flow rate.

If 100% of the pump's flow comes from the main drain system, the maximum water velocity in the pump suction hydraulic system must be six feet per second or less even if one main drain (suction fitting) is completely blocked. The flow through the remaining main drain(s) must comply with the latest ASME/ANSI Specification for *Suction Fittings For Use in Swimming Pools, Spas, Hot Tubs, and Whirlpool Bathtub Applications*.

Piping:

- Use at least 1-1/2" IPS PVC pipe with 5" trap. Use at least 2" pipe with 6" trap. Increase size if a long run is needed.
- To avoid strains on the pump, support both suction and discharge pipes independently. Place these supports near the pump.
- To avoid a strain left by a gap at the last connection, start all piping at the pump and run pipe **away** from the pump.

- Never use a suction pipe smaller than pump suction connection.
- To avoid airlocking, slope suction pipe slightly upward toward the pump.
- **NOTICE:** To prevent flooding when removing pump for service, all flooded suction systems **must** have gate valves in suction and discharge pipes.

Fittings:

- Fittings restrict flow; for best efficiency use fewest possible fittings.
- Avoid fittings which could cause an air trap.
- Pool fittings must conform to International Association of Plumbing and Mechanical Officials (IAPMO) standards.
- Use only non-entrapping suction fitting or double suction.

ELECTRICAL



⚠ Ground motor before connecting to electrical power supply! Failure to ground pump motor can cause serious or fatal electrical shock hazard!

⚠ Do not ground to a gas supply line!

⚠ To avoid dangerous or fatal electrical shock, turn OFF power to motor before working on electrical connections.

⚠ Ground Fault Circuit Interrupter (GFCI) tripping indicates an electrical problem. If GFCI trips and will

not reset, have a qualified electrician inspect and repair electrical system.

⚠ Exactly match supply voltage to nameplate voltage! Incorrect voltage can cause fire or seriously damage motor and voids warranty! If in doubt consult a licensed electrician.

⚠ WARNING Hazardous voltage. Can shock, burn, or kill.

Follow the instructions below when working on pump or wiring.

Voltage:

- Voltage at motor must be not more than 10% above or below motor nameplate rated voltage or motor may overheat, causing overload tripping and reduced component life. If voltage is less than 90% or more than 110% of rated voltage when motor is running at full load, consult power company.

Grounding/Bonding:

- Install, ground, bond and wire motor according to local or National Electrical Code requirements.
- Permanently ground motor. Use green ground terminal provided under motor canopy or access plate (See Figure 2); use size and type wire required by code. Connect motor ground terminal to electrical service ground.
- Bond motor to pool structure. Use a solid copper conductor, size No. 8 AWG (8.4 sq. mm) or larger. Run wire from external bonding lug (see Figure 2) to reinforcing rod or mesh.
- Connect a No. 8 AWG (8.4 sq. mm) solid copper bonding wire to the pressure wire connector provided on the motor housing and to all metal parts of the swimming pool, spa, or hot tub and to all electrical equipment, metal piping or conduit within 5 feet (1.5 m) of the inside walls of swimming pool, spa, or hot tub.

Wiring:

- Pump must be permanently connected to circuit. Table I gives correct wire and circuit breaker sizes for the pump alone. If other lights or appliances are also on the same circuit, be sure to add their amp loads to pump amp load before figuring wire and circuit breaker sizes. (If unsure how to do this or if this is confusing, consult a licensed electrician.) Use the load circuit breaker as the master on-off switch.

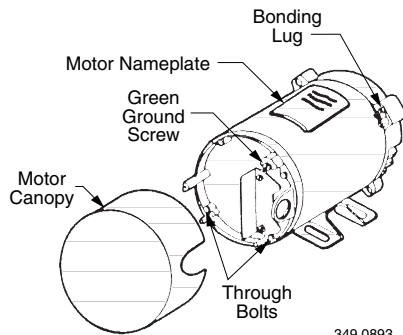

Figure 2: Typical ground screw and bonding lug locations

- Install a Ground Fault Circuit Interrupter (GFCI) in circuit; it will sense a short-circuit to ground and disconnect power before it becomes dangerous to pool users. For size of GFCI required and test procedures for GFCI, see manufacturer's instruction.
- In case of power outage, check GFCI for tripping (which will prevent normal pump operation). Reset if necessary.
- **NOTICE:** If you do not use conduit when wiring motor, be sure to seal wire opening on end of motor to prevent dirt, bugs, etc., from entering.

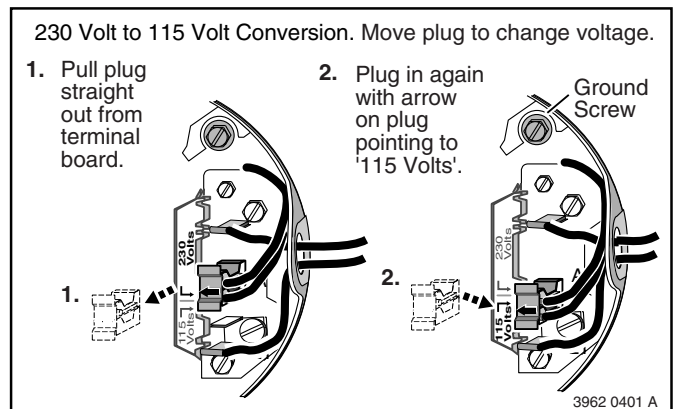
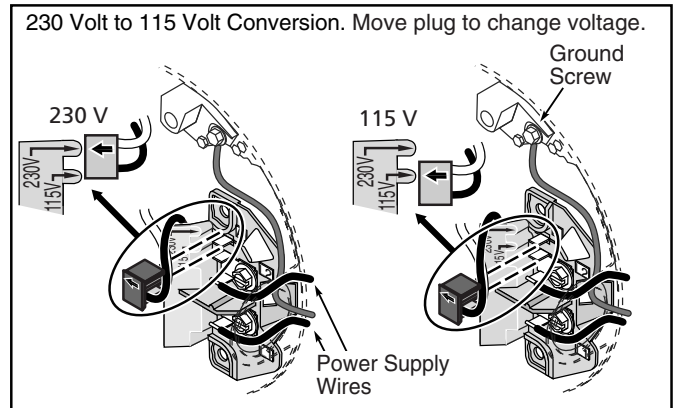

Figure 3: 115/230V wiring connections. Refer to motor nameplate for 3-phase connection diagram.

TABLE I - RECOMMENDED CIRCUIT BREAKER SIZE AND WIRING DATA - 60 Cycle Motors

Motor H.P.	Voltage	Max. Load Amps	Branch Fuse Rating (amps)	Dist. in Ft. (M)-Service to Motor			
				Wire Gauge Size AWG			
				0-50'	51-100'	101-200'	201-300'
3/4	115	12.4	20	12	12	10	8
3/4	230	6.2	15	14	14	14	14
1	115	15.4	20	12	12	8	6
1	230	7.7	15	14	14	14	14
1	230/460/3	3.6/1.8	15/15	14/14	14/14	14/14	14/14
1-1/2	115	18.2	30	10	10	8	6
1-1/2	230	9.1	15	14	14	14	12
2	230	10.4	15	14	14	14	12
2-1/2	230	11.2	20	12	12	12	10

OPERATION

⚠ WARNING



Hazardous suction. Can trap hair or body parts, causing severe injury or death.

Do not block suction.

⚠ NEVER run pump dry. Running pump dry may damage seals, causing leakage and flooding. Fill pump with water before starting motor.

⚠ Before removing trap cover:

1. **STOP PUMP** before proceeding.
2. **CLOSE GATE VALVES** in suction and discharge pipes.
3. **RELEASE ALL PRESSURE** from pump and piping system.

⚠ If pump is being pressure tested, be sure pressure has been released before removing trap cover.

⚠ WARNING **Fire and burn hazard.** Modern motors run at high temperatures. To reduce the risk of fire, do not allow leaves, debris, or foreign matter to collect around the pump motor. To avoid burns when handling the motor, let it cool for 20 minutes before trying to work on it. An automatic internal cutoff switch protects the motor from heat damage during operation.

⚠ Do not block pump suction! To do so with body may cause severe or fatal injury. Small children using pool must ALWAYS have close adult supervision.

Priming Pump:

- Release all pressure from filter, pump, and piping system; see the filter owner's manual.
- In a flooded suction system (water source higher than pump), pump will prime itself when suction and discharge valves are opened.
- If pump is not in a flooded suction system, unscrew T-bolt trap handles and remove trap cover; fill trap and pump with water.
- Clean and lubricate trap cover O-Ring with petroleum jelly each time it is removed.
- Replace trap cover on trap; tighten T-bolt trap handles. Pump should prime now. Priming time will depend on vertical length of suction lift and horizontal length of suction piping.
- If pump does not prime, make sure that all valves are open, suction pipe end is under water and that there are no leaks in suction pipe. See Troubleshooting Guide, Page 9.

STORAGE/WINTERIZING

⚠ Allowing pump to freeze will damage pump and void warranty!

⚠ Do not use anti-freeze solutions (except propylene glycol) in your pool/spa system. Propylene glycol is non-toxic and will not damage plastic system components; other antifreezes are highly toxic and may damage plastic components in the system.

- Drain all water from pump and piping when expecting freezing temperatures or when storing pump for a long time (see instructions below).
- Keep motor dry and covered during storage.
- To avoid condensation/corrosion problems, **do not** cover pump with plastic film or bags.
- For outdoor/unprotected installations:
 1. Enclose entire system in a weatherproof enclosure.
 2. To avoid condensation/corrosion damage, allow ventilation; **do not** wrap system in plastic film.
 3. Use a 40% propylene glycol/60% water solution to protect pump to -50 degrees F.

Draining Pump

⚠ WARNING



Hazardous voltage. Can shock, burn, or cause death.

Disconnect power before working on pump or motor.

1. Pump down water level below all inlets to the pool.

⚠ WARNING **To avoid dangerous or fatal electrical shock hazard, turn OFF power to motor before draining pump.**

2. Remove trap cover and use low pressure air to blow accumulated water from the piping system.
3. Cap inlet piping after draining to keep water out of the pipes.
4. To prevent pump from freezing, remove trap cover and drain the tank body through the drain plug (Key

10, Page 10). Clean pump thoroughly; replace trap cover.

6. Be sure motor is kept dry and covered.

Startup For Winterized Equipment

1. Remove any temporary weather protection placed around system for shutdown.
2. Follow filter manufacturer's instructions for reactivation of the filter.
3. Inspect all electrical wiring for damage or deterioration over the shutdown period. Have a qualified serviceman repair wiring as needed.
4. Inspect and tighten all watertight connections.
5. Open all valves in suction and return piping.
6. Remove any winterizing plugs in piping system.
7. Drain all anti-freeze from system.
8. Close all drain valves and replace all drain plugs in system.
9. Prime pump according to instructions on Page 6.

PUMP SERVICE

Pump should only be serviced by qualified personnel.

Be sure to prime pump (Page 6) before starting.

⚠ WARNING



Hazardous voltage. Can shock, burn, or cause death.

Disconnect power before working on pump or motor.

- ⚠ Before removing trap cover:**
1. **STOP PUMP** before proceeding.
 2. **CLOSE GATE VALVES** in suction and discharge pipes.
 3. **RELEASE ALL PRESSURE** from pump and piping system.

⚠ WARNING To avoid dangerous or fatal electrical shock hazard, turn **OFF** power to motor before working on pump or motor!

- Aside from lubricating trap cover O-Ring, no lubrication or mechanical maintenance is needed beyond

reasonable care and periodic cleaning.

- If shaft seal is worn or damaged, repair as follows:

Pump Disassembly:

- ⚠ Disconnect power to pump motor.**

Be sure gate valves on suction and return piping are closed before starting work.

Release all pressure by opening all vents before starting work.

1. Drain pump by removing drain plugs on bottom of pump body and trap body.
2. **Be sure** there is no pressure in trap body; remove trap cover.
3. Remove nuts (Key No. 6, Page 10), which hold volute in place, thus releasing the volute from the adapter.
4. Hold the motor shaft extension stationary with pliers, and turn the impeller counter-clockwise until it is free from the shaft.
5. Remove the adapter (Key No. 5) from the motor by removing the capscrews (Key No. 17).

REMOVAL OF OLD SEAL INSTALLATION OF NEW SEAL

1. Drive the old seal out of the adapter. Use a piece of pipe or tubing as shown in Figure 4.

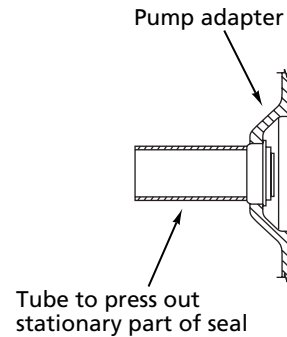

Figure 4

2. Clean the cavity in the adapter. Before installing, coat seal case with sealant compound. Press seal into adapter with a tube or pipe of the correct size to press on the seal rim only, as shown in Figure 5.

NOTICE: Do not touch or scratch the polished carbon face of the seal with the pressing tool.

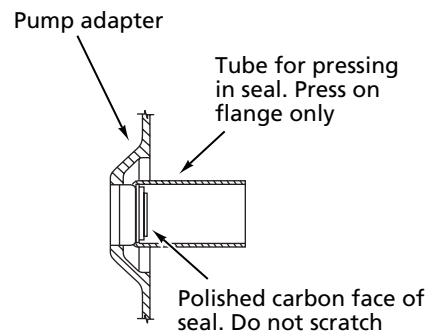

Figure 5

3. Pry loose the ceramic seal in impeller, apply screwdriver between seat and cavity in impeller (Figure 6). Clean cavity from which seat was removed.

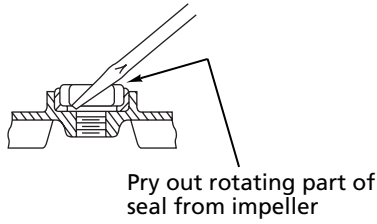

Figure 6

4. Lubricate the rubber ring in the impeller with a soap solution. Press seat into impeller cavity (Figure 7). If a tool or pipe is necessary to press ceramic seat correctly, use a cardboard disc or washer to protect the highly polished ceramic surface of the new seal.

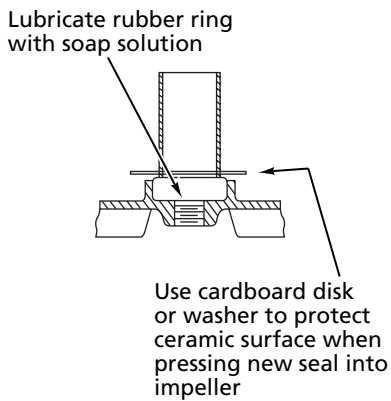



Figure 7

Pump Reassembly:

1. Loosen shaft extension (Key No. 2), so it may be moved along the shaft with ease. Replace adapter on motor and tighten capscrews (Key No. 5).
2. Make certain seal faces are clean. Hold the motor shaft extension stationary and tighten impeller on to shaft.
3. Leaving volute gasket off, place volute on adapter and tighten nuts (Key No. 11A).
4. Push shaft extension and impeller toward volute until impeller touches volute. Tighten set screws (Key No. 3) in place. Remove volute and install gasket (Key No. 8). Place volute on adapter and tighten nuts (Key No. 11A). By this procedure, the proper clearance between impeller face and volute has been established.

TROUBLESHOOTING GUIDE

 **Read and understand safety and operating instructions in this manual before doing any work on pump!**

 **Only qualified personnel should electrically test pump motor!**

⚠️ WARNING Hazardous voltage. Can shock, burn, or cause death. Disconnect power before working on pump or motor.

FAILURE TO PUMP; REDUCED CAPACITY OR DISCHARGE PRESSURE

A. SUCTION LEAKS/LOST PRIME:

1. Pump must be primed; make sure that pump volute and trap are full of water. See priming instructions, Page 6.
2. Make sure there are no leaks in suction piping.
3. Make sure suction pipe inlet to pump is well below the water level to prevent pump from sucking air.
4. If suction trap O-Ring is defective, replace it.
5. Suction lift of 8 feet (2.4M) will reduce performance. Suction lift of more than 10 feet (3M) will prevent pumping and cause pump to lose prime. In either case, move pump closer (vertically) to water source. Make sure suction pipe is large enough.

B. CLOGGED PIPE/TRAP/IMPELLER, WORN IMPELLER:

1. Make sure suction trap is not clogged; if it is, clean trap and strainer.
2. Make sure impeller is not clogged (follow instructions under "Removing Old Seal," Page 7; check impeller for clogging; follow instructions under "Installing New Seal," Page 7, for reassembly).
3. Impeller may be worn. If so, order replacement parts from Repair Parts List, Page 10.
4. Pump may be trying to push too high a column of water. If so, a "higher head" pump is needed.

C. ELECTRICAL

1. Pump may be running too slowly; check voltage at motor terminals and at meter while pump is running. If low, see wiring instructions or consult power company. Check for loose connections.
2. Pump may be too hot.
 - A. Check line voltage; if less than 90% or more than 110% of rated voltage consult a licensed electrician.
 - B. Increase ventilation.
 - C. Reduce ambient temperature.
 - D. Tighten any loose connections.

D. MECHANICAL TROUBLES AND NOISE

1. If suction and discharge are not adequately supported, pump assembly will be strained. See "Installation," Page 3.
2. Do not mount pump on a wooden platform! Securely mount on a concrete platform for quietest performance.

See Page 11 for Exploded View Drawing

REPAIR PARTS LIST

Key No.	Description	Qty.	CFAD-75DL ¾ HP	CFAE-79DL CFAE3-79D 1 HP	CFAF-80DL 1½ HP
1	Motor 115/230V	1	A600DLL	A600ELL	A600FLL
1	Motor 230/460V/3	1	–	J218-920A	–
2	Bonding Lug	1	U17-568	U17-568	U17-568
3	Screw, #10-32x½"	1	U30-692SS	U30-692SS	U30-692SS
4A	Stub Shaft Assembly, 1 Phase (with Set Screws)	1	C110-17	C110-17	C110-17
4A	Stub Shaft Assembly, 3 Phase (with Set Screws)	1	–	C110-17A	–
4B	Set Screw ¼-20x⅜"	3	U30-754SS	U30-754SS	U30-754SS
5	Adapter	1	C2-57D	C2-57D	C2-57D
6	Nut, ⅜"-16	4	U36-38SSW	U36-38SSW	U36-38SSW
7	Stud, ⅜"x1¼"	4	U30-22SS	U30-22SS	U30-22SS
8	Gasket†	1	C20-72	C20-72	C20-72
9	Shaft Seal Package†	1	U109-136SS	U109-136SS	U109-136SS
10	Impeller	1	C5-164D	C5-166D	C5-183D
•	Impeller Screw (3 Phase)	1	–	C30-6SS	–
11	Volute and Trap Body	1	C1-185DB	C1-185DB	C1-185DB
12	Trap Basket	1	C108-33P	C108-33P	C108-33P
13	Cord Ring	1	U9-161	U9-161	U9-161
14	Trap Cover	1	C3-140DC	C3-140DC	C3-140DC
15	Trap Handle	2	C154-18D	C154-18D	C154-18D
16	Pipe Plug, ¼" NPT	2	U78-57DT	U78-57DT	U78-57DT
17	Capscrew ⅜-16x¼"	4	U30-72SS	U30-72SS	U30-72SSS
•	Seal & Gasket Kit	1	PP1150	PP1150	PP1150

† Included in Seal and Gasket Kit.

• Not illustrated.

REPAIR PARTS LIST

Key No.	Description	Qty.	CFAEG-81DL 2 HP	CFAAEG-82DL 2½ HP
1	Motor 230V	1	AE600GLL	AE600G5LL
2	Bonding Lug	1	U17-568	U17-568
3	Screw, #10-32x½"	1	U30-692SS	U30-692SS
4A	Stub Shaft Assembly (with Set Screws)	1	C110-17	C110-17
4B	Set Screw ¼-20x⅜"	3	U30-754SS	U30-754SS
5	Adapter	1	C2-57D	C2-57D
6	Nut, ⅜"-16	4	U36-38SSW	U36-38SSW
7	Stud, ⅜"x1¼"	4	U30-22SS	U30-22SS
8	Gasket†	1	C20-72	C20-72
9	Shaft Seal Package†	1	U109-136SS	U109-136SS
10	Impeller	1	C5-181D	C5-182D
11	Volute and Trap Body	1	C1-185DB	C1-185DB
12	Trap Basket	1	C108-33P	C108-33P
13	Cord Ring	1	U9-161	U9-161
14	Trap Cover	1	C3-140DC	C3-140DC
15	Trap Handle	2	C154-18D	C154-18D
16	Pipe Plug, ¼" NPT	2	U78-57DT	U78-57DT
17	Capscrew ⅜-16x¼"	4	U30-72SS	U30-72SS
•	Seal & Gasket Kit	1	PP1150	PP1150

† Included in Seal and Gasket Kit.

• Not illustrated.

EXPLODED VIEW
"CFA" BRONZE SERIES
Self Priming Centrifugal Pump

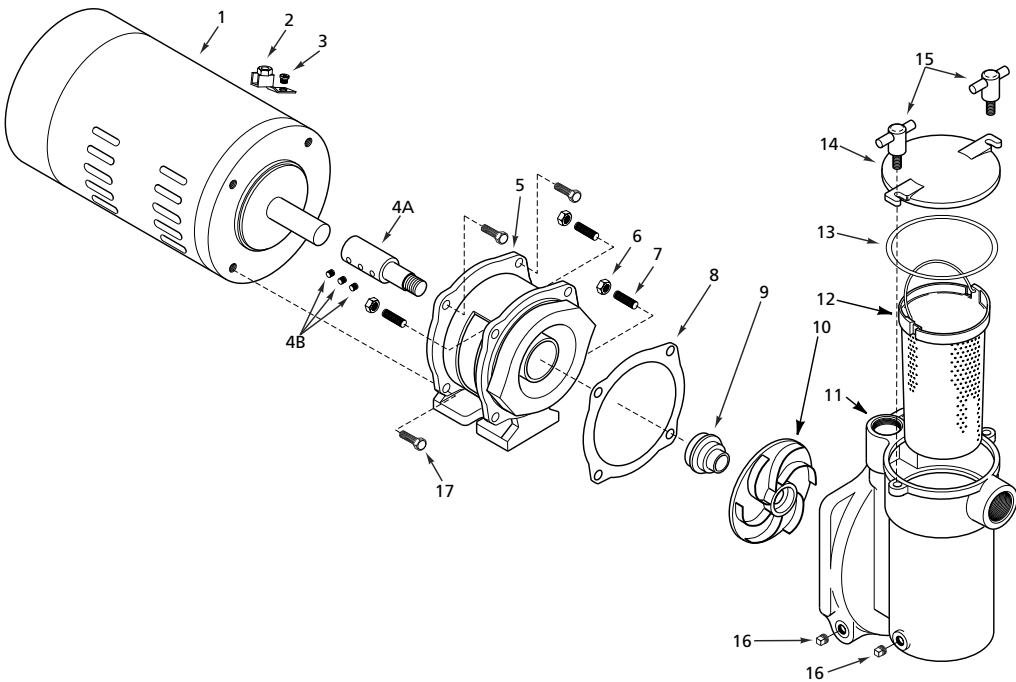

STA-RITE LIMITED WARRANTY

Pumps, filters, skimmers, underwater lights (except bulbs), accessories and fittings manufactured by Sta-Rite are warranted to be free of defects in material and workmanship for one (1) year from date of installation.

Product specific warranties: **Year from date of installation**

<i>HRPB, DEPB, System 3, System 2 and Posi-Clear</i>	
Tanks	10 years
Internal filter components and valves	1 year
<i>Max-E-Therm - Pool/Spa Heaters</i>	
Heater Enclosure only (Upper RH & LH; lower enclosure; and control board enclosure)...	10 years
<i>Automatic Pool Cleaners including Hose</i>	
	2 years
<i>Cristal-Flo filters - Tanks</i>	
Valve and internal components.	1 year
<i>Posi-Flo II - Tanks</i>	
Elements	1 year
<i>PRC Cartridge -</i>	
Filter Tanks	5 years pro-rated (1st 2 years full)
Elements	1 year
<i>System 2 Above Ground Systems - Tanks</i>	
Pumps / Platform and Internals	1 year
<i>Pumps</i>	
When equipped with A.O. Smith 2-compartment motors (Does not include pumps sold as part of a systems package)	2 years
<i>Traps / In-Line Strainers</i>	
	1 year
<i>Vertical Commercial Filter - Tanks</i>	
Internals	1 year
<i>Horizontal Commercial Filter</i>	
Tanks	5 years (Years 6-9, Prorated declining 20%/year, Yr. 10 - 10%)
Internals	1 year

* Full warranty coverage is in effect for one year after installation. The pro-rated warranty covers the *tank only* during the 2nd through 10th year after installation. The amount covered decreases by 10% each year. (ie., 2nd year 90% covered, 3rd year 80% covered, etc.).

The foregoing warranties relate to the original consumer purchaser ("Purchaser") only. Sta-Rite shall have the option to repair or replace the defective product, at its sole discre-

tion. Purchasers must pay all labor and shipping charges necessary to replace the product covered by this warranty. Requests for warranty service must be made through the installing dealer. This warranty shall not apply to any product that has been subject to negligence, misapplication, improper installation or maintenance, or other circumstances which are not in Sta-Rite's direct control.

This warranty sets forth Sta-Rite's sole obligation and Purchaser's exclusive remedy for defective products.

STA-RITE SHALL NOT BE LIABLE FOR ANY CONSEQUENTIAL, INCIDENTAL OR CONTINGENT DAMAGES WHATSOEVER.

THE FOREGOING WARRANTIES ARE EXCLUSIVE AND IN LIEU OF ALL OTHER EXPRESS WARRANTIES. IMPLIED WARRANTIES, INCLUDING BUT NOT LIMITED TO THE IMPLIED WARRANTIES OF MERCHANTABILITY AND FITNESS FOR A PARTICULAR PURPOSE, SHALL NOT EXTEND BEYOND THE DURATION OF THE APPLICABLE EXPRESS WARRANTIES PROVIDED HEREIN.

Some states do not allow the exclusion or limitation of incidental or consequential damages or limitations on how long an implied warranty lasts, so the above limitations or exclusion may not apply to you. This warranty gives you specific legal rights and you may also have other rights which vary from state to state.

Supersedes all previous publications.

Sta-Rite Industries, Inc.,
293 Wright St., Delavan, WI 53115

▲ Retain Warranty Certificate (upper portion) in a safe and convenient location for your records.

DETACH HERE: Fill out bottom portion completely and mail within 10 days of purchase/installation to:

▼ Sta-Rite, Attn: Warranty Dept., 293 Wright St., Delavan, WI 53115

STA-RITE®



Warranty Registration Card

Name _____

Years pool has been in service less than 1 1-3 3-5 5-10

Address _____

Purchased from:
Company name _____

City _____ State _____ Zip _____

Address _____

Purchase Date _____

City _____ State _____ Zip _____

Product Purchased _____

New installation Replacement

Please send me more information on these other products from Sta-Rite.

Type of Pool Inground Vinyl Fiberglass Gunite

- Pumps Filters Automatic Pool Cleaners
- Maintenance Equipment Test Strips
- Heaters

Size of Pool _____