

### AP-PRO PLUS



### Filtro autopulente Self cleaning filter



#### DESCRIZIONE/DESCRIPTION

Filtro di protezione innovativo per la rimozione di particelle in sospensione, sabbia e metalli. Prodotto con corpo in Delrin, attacchi entrata/uscita posti su piastra ruotabile a 360° in ottone, vaso SAN trasparente, valvola di scarico in plastica. Il filtro è fornito completo di cartuccia filtrante in nylon lavabile.

L'acqua entra nel filtro e attraverso la cartuccia dall'interno all'esterno, e ne esce pulita. Girando in senso antiorario la manopola si attiva il lavaggio con acqua ad alta velocità, grazie al principio di funzionamento "Venturi" del cilindro plastico interno. L'acqua sporca fuoriesce dalla valvola di scarico. Per terminare l'operazione di lavaggio della cartuccia girare la manopola in senso orario. Durante l'operazione di pulizia della cartuccia non si interrompe la fornitura di acqua filtrata alla rete.

*Innovative protection filter to remove suspended particles, sand and metal particles. Manufactured with Delrin body, 360° rotating brass Inlet-Outlet connection plate, transparent SAN bowl, plastic drain valve. The filter is supplied complete with nylon filtering element. The water enter the filter and flows down to the cartridge from inside to outside.*

*A simple turning counter-clockwise of the knob activates high speed-wash with water, by the "Venturi" functioning principle of the interior plastic slot cylinder.*

*Dirty water goes out by the drain valve. To finish cartridge cleaning operation turn clockwise the knob. No interruption of filtered water supply during cartridge-washing operation.*



#### CARATTERISTICHE TECNICHE/TECHNICAL FEATURES

Testa/Head	DELIRIN con flangia in ottone DELIRIN with brass flange
Vaso/Sump	SAN trasparente Transparent SAN
O-ring/O-ring	NBR
Cartuccia/Cartridge	RLA-AP
Micron/Micron	89
Pressione max./Max Working pressure	10 bar max
Pressione min./Min Working Pressure	1,5 bar max
Pressione di scoppio/Burst Pressure	40 bar max
Temperatura min./Min Working Temperature	5°C
Temperatura max./Max Working Temperature	40°C
Test invecchiamento/Life test	200.000 cicli da 0-10 bar 200.000 cycles from 0-10 bar



#### MANOMETRO/MANOMETER

E' possibile inserire il manometro sia in ingresso che uscita.  
It is possible to put a manometer both at the entrance and at the exit of the filter.



Attacchi entrata/uscita in ottone, ruotabile a 360°.  
Inlet-outlet brass connection plate, can be turned 360°.

Codice Code	Modello Model	Inlet/Outlet Inlet/Outlet	Portata consigliata Recommended Flow-Rate	Portata massima Max Flow-Rate	Dimensioni Dimensions	Quantità imballo Quantity pack
A8000040	AP PRO PLUS	F 1" 1/4	m3/h $\Delta p=0,2$ BAR	m3/h $\Delta p=0,5$ BAR	axb (mm)	6
A8000050	AP PRO PLUS	F 1" 1/2	5,0	7,4	198 x 398	6
			6,0	8,9	257 x 398	6



#### MANOVRA PER LA PULIZIA/CLEANING PROCEDURE

Ruotare 5 volte in senso antiorario la manopola posizionata nella parte superiore del filtro (A). La rotazione avvia l'aspirazione della particelle trattenute sulla superficie interna del filtro e lo di scarico inferiore. Ruotare 5 volte in senso orario la manopola fino alla completa chiusura dello scarico inferiore. (B).

Turn 5 times the knob counterclockwise (A). The rotation activate the aspiration of the particles retained by the cartridge net and, at the same time, open the drain. Turn 5 times the knob clockwise, till the discharge valve is completely closed (B).



#### DIMENSIONI/DIMENSIONS

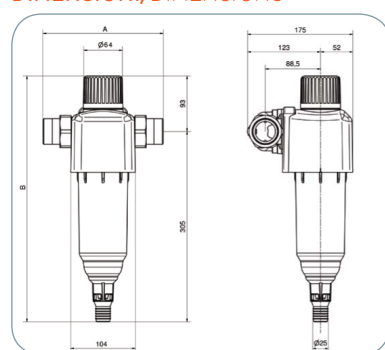

#### ACCESSORI E RICAMBI/ACCESSORIES AND SPARE PARTS



Codice Code	Descrizione Description
A800C020	Cartuccia RLA 1"1/4-1" 1/2/RLA Cartridge 1" 1/4-1" 1/2
A8001000	Chiave per vaso/Bowl key
A800M010	Manometro 0-16 BAR MG 1/8" completo di kit Complete kit with manometer 0-16 BAR MG 1/8"



#### SCATOLA/BOX



#### QR code

Vai direttamente all'approfondimento  
Get more detailed information