

Station Stop Timer from 5 sec to 5 minutes. MR350

This project adds a Station Stop Timer to your layout. This will allow you to run your train on a continuous loop with it stopping each time it gets to a station.

The basic principle is to have a section of track inside the station isolated from the power, and switched ON and OFF by a electronic timer.

How to Install the system.

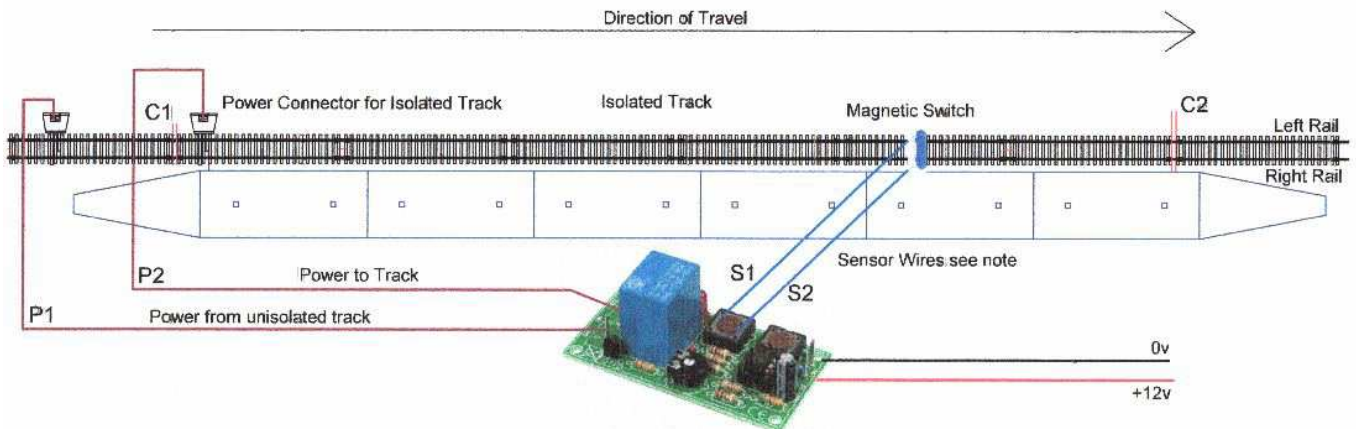

The first thing you need to do is replace either the left or right track fishplates with 'Insulated Fishplates' in positions C1 & C2 to the nearest joint.

Next fit 2 Power Connectors, 1 on the un-insulated side of C1, and one on the insulated side of C1. If you have fitted insulated fishplates to the left track then connect a wire P1 & P2 to both of the Power Connectors left track contact. The P1 wire goes to the Common connector on the Timer board (Com). The other wire P2 goes to the Normally Closed contact (NC). *Without power on the timer you should now still have power on all parts of the track.*

The next step is a little trial and error, fitting the 'Reed Sensor'. You want it to cut power to the train at the right point so the train stops with coaches and engine against the platform. There will be a certain amount of over run depending on the speed of the train. Test this by running the train and then pulling out the wire of the Insulated Power connector when you want the train to stop. This should give you a good indication where the sensor should be placed.

You need to solder a wire to each of the pins on the Reed Switch, long enough to get back to where you are positioning the timer. Now drill 2 holes (2mm) between the sleepers at the distance the pins are apart (12mm)

The kit comes with 1 miniature magnet which should be fitted on the under side of the locomotive. You now need to fit the reed switch to the space between the sleepers, and check the clearance by running the loco over the reed switch.

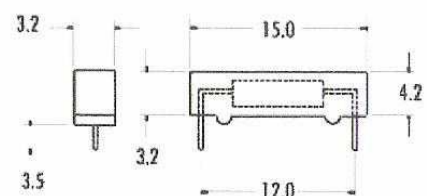

The Timer

The next job is to assemble the timer circuit and test it before connecting it. Please follow the instructions provided with the timer kit.

Remember not to fit the 2 push button switches, you will not need them.

You are replacing the 'Start' Switch with the 'Reed Switch'. There are 6 holes for connecting the switch, the 2 larger ones are locating holes only. The 2 on the left are connected together by the printed circuit board as are the 2 on the right. You need to connect one wire to a left hole and one to the right hole. This is now your start switch. The stop switch is not required in this application.

PTO

Connect all wires as shown in the drawing below.

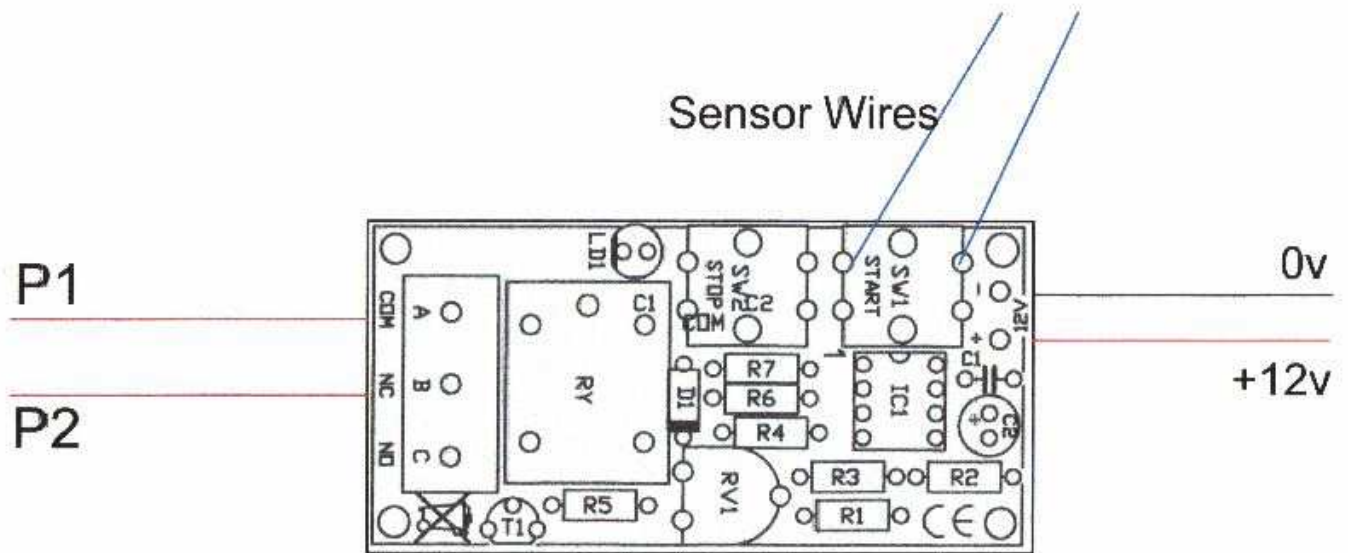

RV1 on the printed circuit board is the timer control trimmer. Turn the trimmer all the way counter clockwise, and then a small amount clockwise, this should give a small OFF delay to check the circuit. Once you have proved the circuit then set the RV1 trimmer to your desired time delay.



Parts List











Timer Kit	EM121 (1)
Reed Switch	SW927 (1)
Magnet	SW932 (1)
Track Insulators	By others (4)
Power connectors	By others (2)

NOTE:

- 1) By adding our EM134 relay card to the above circuit you can control the electric light signals around the station, with a stop indication on the control panel, see project 'Station Stop Timer & Signals'.
- 2) By adding our EM135 relay card to the above circuit you can switch OFF both tracks and control the signals around the station, with a stop indication on the control panel, see project 'Station Stop Timer & Signals'

The following is a list of Sensor equipment that can be used on Model Railway layouts to indicate positions or activate other circuits.

Magnets		SW930	Permanent magnet 5 x 22mm
		SW931	Permanent Magnet 19.5 x 3.17 x 3.17mm
		SW932	This is a 6mm diameter by 2mm high magnet with a small indent on one side to indicate the North side. Can be glued to the underside of Locomotives or carriages to activate sensor switches. Take care when locating this for clearance

		SW933	This is a 3mm diameter by 2mm high magnet with a small indent on one side to indicate the North side. Can be glued to the underside of Locomotives or carriages to activate sensor switches. Take care when locating this for clearance
Reed Sensor Switches		SW923	General purpose glass magnetic reed switch, suitable for a wide range of sensing applications. Normally open contact. Ideal for use as points position detector. Length 10.5mm, Diameter 2.2mm Current Rating 1.25 Amps.
		SW925	General purpose glass magnetic reed switch, suitable for a wide range of sensing applications. Normally open contact. Ideal for use as points position detector. Length 18.5mm, Diameter 2.6mm Current Rating 0.5 Amps.
		SW926	Encapsulated magnetic reed switches, Normally open contact. Switching current 0.5 Amps. Size 20mm long, 3.2mm wide, 4.2mm high. Lead spacing 18mm. Operating Distance 5 to 18mm.
		SW927	Encapsulated magnetic reed switches, Normally open contact. Switching current 100mA. Size 15mm long, 3.2mm wide, 4.2mm high. Lead spacing 12mm. Operating Distance 5 to 12mm.
		SW928	General purpose glass magnetic reed switch, suitable for a wide range of sensing applications. Changeover contact. Ideal for Switching from one state to another e.g. signal lights, etc. Length 14.5mm, Diameter 2.54mm Current Rating 0.2 Amps.
Leaf Switch		SWP100	This Leaf switch is a direct replacement of the Peco PL-32 open micro switch. The switch is used as a points position detector. The switch can then be used to indicate points position, by switching control panel lights. Can also be used to switch signal lights
Micro-switch		SW032	V3 type standard size micro switches with blade actuator. S.P.D.T Switching. Ideal for all position sensing. Can be fitted beside points to be activated by the points lever. Lever 51mm Long. Current Rating 5 Amps
		SW033	V3 type standard size micro switches with blade actuator. S.P.D.T Switching. Ideal for all position sensing. Can be fitted beside points to be activated by the points lever. Lever 28mm Long. Current Rating 5 Amps
		SW052	V4 type ultra-miniature micro switches with blade actuator. S.P.D.T Switching. Ideal for all position sensing. Can be fitted beside points to be activated by the points lever.
		SW054	V4 type ultra-miniature microswitches with roller actuator. S.P.D.T Switching. Ideal for all position sensing. Can be fitted beside points to be activated by the points lever.