

Subsea Tooling Services Range of Dredgers



Subsea Tooling Services UK Ltd (STS) has a large selection of ROV / Diver operated dredgers. The range includes 3" 4" 6" 8" 10" and 12" dredgers. We are confident we have a dredger that will suit most applications.

Our dredgers have been designed and built to the highest standards by experienced engineers and fabricators.

All our dredgers and associated parts are made in Scotland.

Using cutting edge fluid dynamic technology our dredgers are the most efficient in the current market.

When designing our unique high performance dredgers Subsea Tooling Services took into account the people who have to use these machines. Their safety is our number one priority. All Subsea Tooling Services dredgers are self-standing units with certified lifting points to ensure safe handling. Each dredger system has its own dedicated storage box that houses the dredger and associated components.

Our range of unique dredgers are easy to use, both by Remotely Operated Vehicles and divers. The STS dredger can be assembled / disassembled subsea without the need to recover the ROV or diver frame.

This new generation of dredge systems can be configured subsea to either dredge or jet without the need for ROV / Diver frame recovery. By simply swapping out some sub components the dredger can be converted into a high volume jet pump which can be used in conjunction with the STS jetting lance.

As our dredgers can be re-configured for different tasks subsea without the need for ROV recovery, this can save considerable vessel time especially when working in deep waters.

All our dredgers sub components can be stored in one of our unique subsea baskets when not in use.

Subsea Tooling Services Dredger Configuration

The Subsea Tooling Services range of *Predator* dredgers can be configured for various work scopes. Our Dredgers can be easily adapted from one mode to another depending on what type of dredging is required.

The transition between different modes can be undertaken subsea with the use of a 2nd work class ROV or simply by a diver if the *Predator* or *Gremlin* is fitted to the Diver dredge frame.

The dredger sub components can be deployed in an ROV work basket, and used as and when required.

When dredging work is complete the components can be removed from the main dredger assembly allowing the work class ROV to continue with normal operations without the need for recovery to remove the dredging equipment.

Our remote exhaust system means that the dredged spoil can be deposited at least 10 meters from the work site. This helps keep visibility clear and ensures the spoil will not build up near the dredged work area.

A long 10m suction hose can also be fitted to the dredger intake.

Below picture shows the Subsea Tooling Services 6" *Predator* set up on the dredge deployment frame & remote exhaust system

Conventional Dredging mode involves the dredger system being mounted to the side of a work class ROV or to a diver frame, and utilises the standard components supplied with the system.

This configuration utilises a 3000mm length of suction hose and the 3 different suction heads.



As standard, the *Predator* or *Gremlin*, comes with a jetting agitator that clamps on to the suction head and is most commonly used when dredging heavy clay or solidified drill cuttings. The agitator takes its water supply directly from the pump and can be used at the same time as dredging operations.

In the event of heavy seabed conditions the Subsea Tooling Services dredger can be configured to operate the high volume low pressure seabed saturation lance. This lance can be deployed in a work basket, and can be fitted subsea by a 2nd work class ROV.

By simply removing the exhaust and suction hose and fitting a blanking plate to the exhaust end of the dredger or activating the integrated back flush which comes as standard on the MKII T6, this turns the dredger into a high volume pump to saturate the solidified drill cuttings once the lance is stabbed into the seabed.

Once satisfied the cuttings / seabed have been loosened up with the lance, the dredger can then be reconfigured subsea back into dredging mode.



4 x MKII T6 Predator Dredgers with hydraulic backflush

Below picture shows the Subsea Tooling Services 6" *Predator* dredger undergoing performance testing at the Underwater Centre in Fort William Scotland.

See the *Predator* in action: <https://www.youtube.com/watch?v=BQSYZ4MJYg>

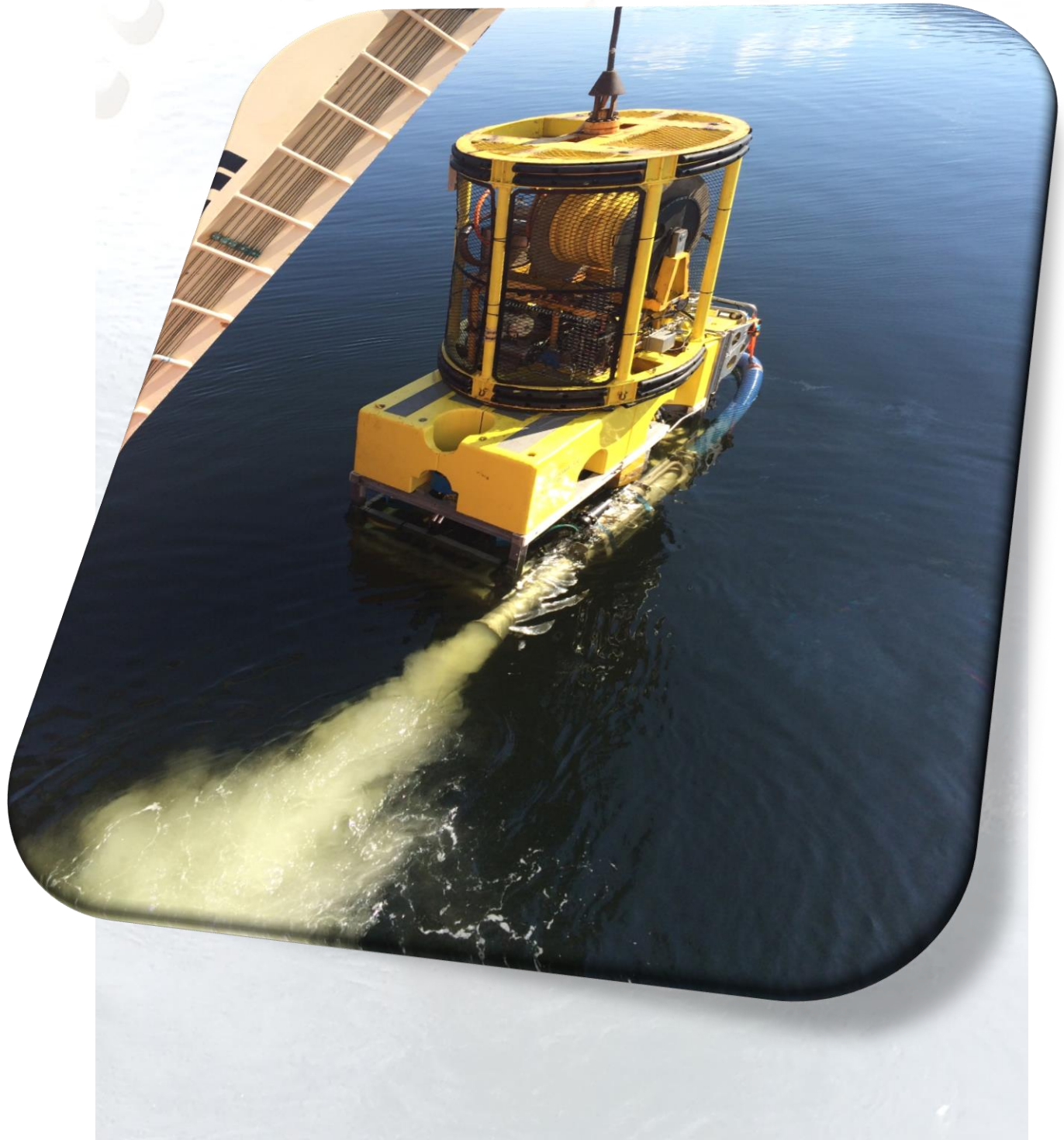

Subsea Tooling Services 6" *Predator* dredger dredging a rock dump during performance testing trials at the Underwater Centre Fort William Scotland



Power & Performance

Reliability

Engineered with safety as a priority

Designed by experts in their field

Adaptability

Technologically advanced

Operationally efficient

Rigorously tested

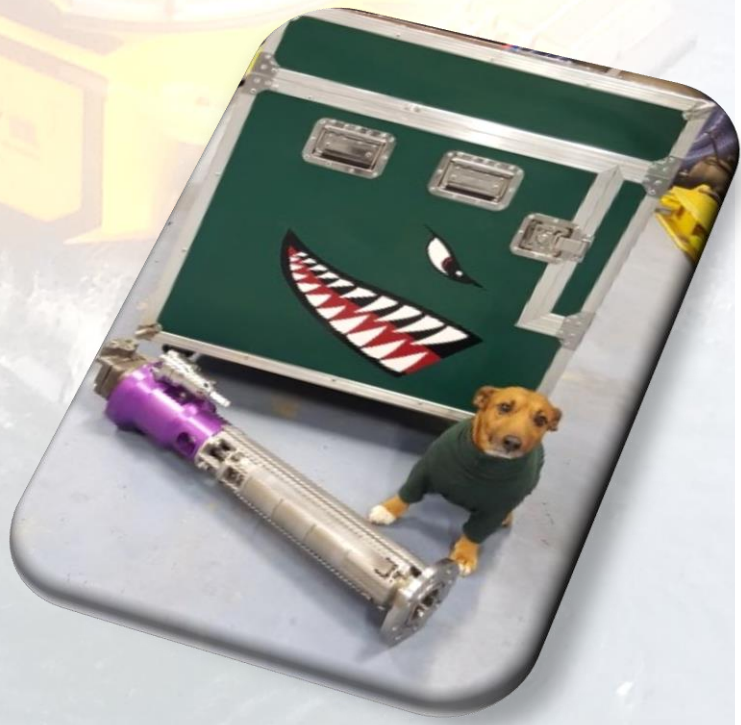



Picture above shows the heavy clay agitator bolted to the 6" Predator dredger suction head

Picture below shows the high pressure heavy clay agitator jetting nozzles acting upon a solid clay seabed



The Subsea Tooling Services range of dredgers all come as standard with a universal mounting frame so that they can be safely & securely mounted to the side of any type of work class ROV, avoiding the use of cargo straps & rope.

Picture right shows a *Predator* MKI T6-8 Hybrid Mounted to the side of a Triton XL ROV

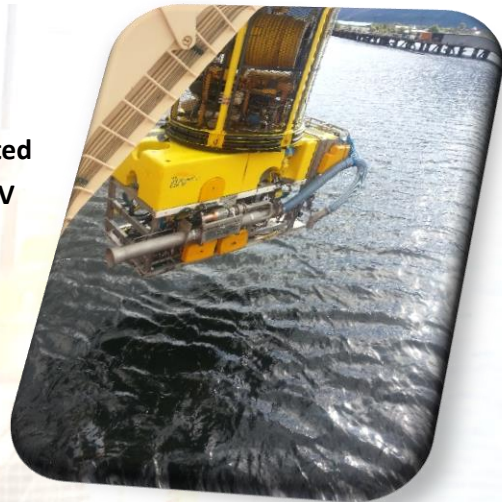

Picture to the left shows a *Predator* MKI T6-8 Hybrid dredger mounted to a Centurion HD ROV

Picture to the right shows a *Predator* MKI T-8 mounted to SMD Quantum ROV



Picture Left shows a *Predator* MKI T6-8 Hybrid side mounted to Triton MRV ROV

The Subsea Tooling Services range of dredgers can also be mounted into an ROV skid. As our dredgers have an integral chassis designed for ease of mounting this makes them very easy to adapt into any type of ROV tooling skid, whether upright or side mounted.

During the summer of 2015 Subsea Tooling Services worked very closely with one of our clients to design and develop a dredging skid that contained 2 x side mounted *Predator* MKII T-6 dredger systems that were designed to dredge simultaneously either side of a 12" pipeline.

The *Predator* MKII T-6 comes with a back flush valve as standard and this system proved to be very efficient and reliable during the work scope.



Subsea Tooling Services Intelligent Dredging System (IDS)



- Optional extra for *Grenlin, Predator & Titan* range of dredgers
- Ensures maximum hydraulic efficiency is supplied to dredger motor
- Built in depth compensator
- Easily mounted to any work class ROV
- Soft Start / Stop function built into topside software to avoid damage to hydraulic motors during start-up & sudden stoppage
- Monitors input pressure & flow and indicates if these are insufficient for the type of dredger being used
- Gives user complete control of the pressure & flow being supplied to dredger
- 2 x pressure proportional NG#3 valves for operating auxiliary tooling (MKII Back flush etc)
- Water ingress alarm
- Hard anodised casing for corrosion prevention
- Clear plastic observation window shows valve pack LED status
- Monitors and displays hydraulic oil temperature
- User friendly GUI (Graphical User Interface)

Operational Specification

Hydraulic Flow	0 – 150 Litres per minute
Hydraulic Pressure Range	0 – 250 Bar
Voltage	24V DC
Dimensions of Valve Pack L x W x H x W Kg	370mm x 320mm x 238mm x 25Kg
Depth Rating	3000 MSW
Communications Protocol	RS232 (Standard) RS485 (Optional)
Dimensions of Transit Case L x W x H	1200mm x 640mm x 700mm
Electrical Connection	Burton 8 pin electrical connector 5507.1508.0004.PE8
Surface Control	Laptop Computer c/w RS232 – USB convertor + power supply

Subsea Tooling Services IDS valve pack is a revolution in modern dredging technologies.

Our IDS ensures our subsea dredgers are used to their maximum efficiency during operations and allows the user to have complete control of the dredging system independent from the ROV system.



Subsea Tooling Services *Cobra Suction Head*

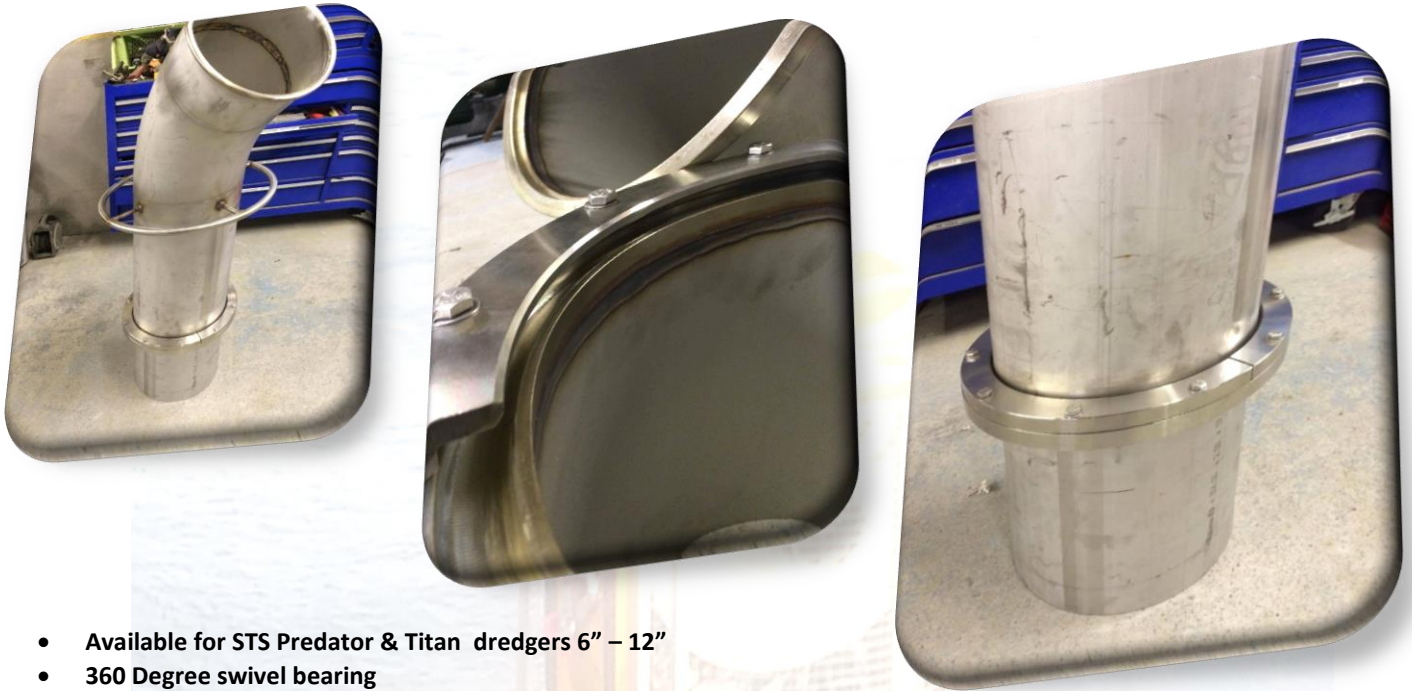

- Available for STS Predator & Titan dredgers 6" – 12"
- 360 Degree swivel bearing
- Comes with Diver / ROV friendly grab handle
- Made from Stainless Steel
- Stainless Steel bearing assembly
- Push – Fit hose end
- No loss of suction from the sealing ring

The STS Cobra Suction Head has been designed to reduce wear on vital manipulator parts by taking away the torque generated by the suction hose. This gives the ROV or diver much more manoeuvrability of the suction head during dredging operations.

With a 360 degree ring bar handle the cobra head can be picked up in any orientation and operated easily, eliminating excess stress on expensive manipulator parts.

Our stainless steel sealing ring ensures no loss of suction from the dredger during operations and avoids the use of greased components coming into contact with abrasive sands.



Subsea Tooling Services 3" *Gremlin* Dredger



- Can be mounted to any Work Class / Observation Class ROV safely and quickly
- Certified ROV mounting frame for fast mobilisation & on deck turnaround
- Optimum dredging up to 40mm rocks
- Easily adapted to ROV or Diver use
- Self-standing frame
- Cam-Lock hose connectors for quick & easy connections
- Twin balanced shaft bearings which prolongs hydraulic motor life
- Depth compensated bearing housing provides unlimited depth
- Lightweight design

Operational Specification

Hydraulic Flow	15 – 20 Litres per minute
Optimal Hydraulic Pressure	150 – 200 Bar
Gross Water Flow	15 m ³ /h
Removal Capacity Sand (t/h)*	22 Tons per hour
Removal Capacity Rocks (t/h)*	15Tons per hour
Unrestricted Diameter	75mm
Dimensions of Dredger L x W x H x W Kg	1100mm x 125mm x 320mm x 27 Kg (Weight in Water = 18 Kg)
Dimensions of Transit Case L x W x H	1170mm x 370mm x 560mm
Hydraulic Hoses Supplied	3 x ½" Certified Hose's 3000mm Long c/w 8 JIC Female Swivel Ends

* Removal capacity is theoretical, removal rates will vary depending on the type of seabed being dredged.

The STS 3" Gremlin system is a completely new concept in performance dredging. Its unique features make it the most efficient 3" dredger on the market saving both vessel and operational time.

The dredger can be easily mounted to the host ROV using its dedicated interface frame or mounted to the standard STS dredge deployment frame for diver use.

While optimum performance has always been a priority with this system, safety has also been a top priority. As such the *Gremlin* features a self-standing frame which means the dredger will sit upright on its own, which will help avoid manual handling injuries whilst fitting the dredger to the ROV or deployment frame.

Optimum performance is achieved by utilising the latest fluid dynamic research.



Subsea Tooling Services 4" MKI T4 ROV *Predator* Dredger



- Can be mounted to any Work Class ROV safely & quickly
- Certified lifting points & rigging
- Can be assembled / disassembled subsea by work class ROV / Diver
- Certified ROV mounting frame for fast mobilisation & on deck turnaround (optional)
- Can be configured for dredging or jetting subsea without need for ROV recovery (x 2 WROV required)
- Depth rated to 5000 MSW
- Optimum dredging up to 90mm rocks
- Comes with clay jetting nozzle & agitator as standard
- Optional lengths of suction / discharge hoses that can be changed out subsea
- Easily adapted to ROV or Diver use
- Can be converted to jetting mode subsea

Operational Specification

Hydraulic Flow	40 – 60 Litres per minute
Optimal Hydraulic Pressure	180 – 210 Bar
Gross Water Flow	4000 Litres per minute (Through Ejector)
Removal Capacity Sand (t/h)*	30 metric tons per hour
Removal Capacity Rocks (t/h)*	15 metric tons per hour
Unrestricted Diameter	100 mm
Dimensions of Dredger L x W x H	1700mm x 450mm x 225mm
Dimensions of Transit Case L x W x H	1200mm x 640mm x 680mm
Hydraulic Hoses Supplied	3 x Certified Hose's 3000mm Long c/w JIC Female Swivel Ends

* Removal capacity is theoretical, removal rates will vary depending on the type of seabed being dredged.

The STS *Predator* system is a completely new concept in performance dredging. Its unique features make it the most efficient dredger on the market saving both vessel and operational time.

The dredger can be easily mounted to the host ROV using its dedicated interface frame.

While optimum performance has always been a priority with this system, safety has also been a top priority. As such the *Predator* features certified lifting points and associated rigging and when placed on the deck the dredger sits upright on its integrated frame reducing the risk of manual handling injuries.

Optimum performance is achieved by utilising the latest fluid dynamic research.

The STS *Predator* can be assembled or disassembled subsea minimising ROV recovery time and increasing vessel productivity.



Subsea Tooling Services 6" MKI T6-8 ROV *Predator* Dredger



- Can be mounted to any Work Class ROV
- Certified lifting points & rigging
- Can be assembled / disassembled subsea by work class ROV / Diver
- Certified ROV mounting frame for fast mobilisation & on deck turnaround (optional)
- Can be configured for dredging or jetting subsea without need for ROV recovery (x 2 WROV required)
- Depth rated to 5000 MSW
- Optimum dredging up to 110mm rocks
- Comes with clay jetting nozzle & agitator as standard
- Optional lengths of suction / discharge hoses that can be changed out subsea
- Easily adapted to ROV or Diver use
- Can be converted to jetting mode subsea

Operational Specification

Hydraulic Flow	55 – 80 Litres per minute
Optimal Hydraulic Pressure	180 – 210 Bar
Gross Water Flow	7500 Litres per minute
Removal Capacity Sand (t/h)*	65 metric tons per hour
Removal Capacity Rocks (t/h)*	55 metric tons per hour ** Based on a rock size of 50 – 120mm rocks**
Unrestricted Diameter	150mm
Dimensions of Dredger L x W x H	2440mm x 450mm x 640mm
Dimensions of Transit Case L x W x H	1900mm x 750mm x 650mm
Hydraulic Hoses Supplied	3 x Certified Hose's 3000mm Long c/w 8 JIC Female Swivel (6 JIC Case)

* Removal capacity is theoretical, removal rates will vary depending on the type of seabed being dredged.

The STS *Predator* system is a completely new concept in performance dredging. Its unique features make it the most efficient dredger on the market saving both vessel and operational time.

The dredger can be easily mounted to the host ROV using its dedicated interface frame.

While optimum performance has always been a priority with this system, safety has also been a top priority. As such the *Predator* features certified lifting points and associated rigging and when placed on the deck the dredger sits upright on its integrated frame reducing the risk of manual handling injuries.

Optimum performance is achieved by utilising the latest fluid dynamic research.

The STS *Predator* can be assembled or disassembled subsea minimising ROV recovery time and increasing vessel productivity.

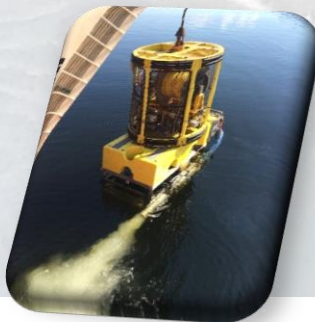

Subsea Tooling Services 6" MKII T6 ROV *Predator* Dredger



- Can be mounted to any Work Class ROV safely & quickly
- Certified lifting points & rigging
- Can be assembled / disassembled subsea by work class ROV / Diver
- Certified ROV mounting frame for fast mobilisation & on deck turnaround
- Can be configured for dredging or jetting subsea without need for ROV recovery (x 2 WROV required)
- Depth rated to 5000 MSW
- Optimum dredging up to 110mm rocks
- Comes with clay jetting agitator nozzle as standard
- Optional lengths of suction / discharge hoses that can be changed out subsea
- Easily adapted to ROV or Diver use
- Can be converted to jetting mode subsea
- Hydraulic Back Flush Unit reverse flow
- Remote flexi exhaust system

**Now comes
with
hydraulic
back flush as
standard!!!**

Operational Specification

Hydraulic Flow	60 – 100 Litres per minute
Optimal Hydraulic Pressure	180 – 210 Bar
Gross Water Flow	6000 Litres per minute (Through Ejector)
Removal Capacity Sand (t/h)*	65 metric tons per hour
Removal Capacity Rocks (t/h)*	50 metric tons per hour ** Based on a rock size of 50 – 100mm **
Unrestricted Diameter	150mm
Dimensions of Dredger L x W x H (Assembled)	2600mm x 300mm x 630mm x 120Kg
Dimensions of Transit Case L x W x H	2109mm x 840mm x 970mm
Hydraulic Hoses Supplied	3 x Certified Hose's 3000mm Long c/w 8 JIC Female Swivel (6 JIC Case)

* Removal capacity is theoretical, removal rates will vary depending on the type of seabed being dredged.

The STS *Predator* MKII T-6 system is a completely new concept in performance dredging. Its unique features make it the most efficient dredger on the market saving both vessel and operational time.

The dredger can be easily mounted to the host ROV using its dedicated interface frame or mounted inside a ROV skid.

While optimum performance has always been a priority with this system, safety has also been a top priority. As such the *Predator* features certified lifting points and associated rigging and when placed on the deck the dredger sits upright on its integrated frame reducing the risk of manual handling injuries.

Optimum performance is achieved by utilising the latest fluid dynamic research.

The MKII T-6 can be assembled or disassembled subsea minimising ROV recovery time and increasing vessel productivity.

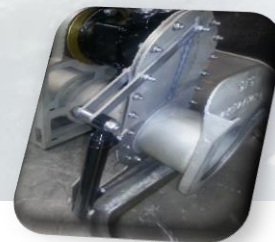

Subsea Tooling Services 8" MKI T8 ROV *Predator* Dredger



- Can be mounted to any Work Class ROV safely & quickly
- Certified lifting point & rigging
- Can be assembled / disassembled subsea by work class ROV / Diver
- Certified ROV mounting frame for fast mobilisation & on deck turnaround (optional)
- Can be configured for dredging or jetting subsea without need for ROV recovery (x 2 WROV required)
- Depth rated to 5000 MSW
- Optimum dredging up to 150mm rocks
- Comes with clay jetting nozzle & agitator as standard
- Optional lengths of suction / discharge hoses that can be changed out subsea
- Easily adapted to ROV or Diver use
- Can be converted to jetting mode subsea

Operational Specification

Hydraulic Flow	55 – 80 Litres per minute
Optimal Hydraulic Pressure	180 – 210 Bar
Gross Water Flow	8000 Litres per minute (Through Ejector)
Removal Capacity Sand (t/h)*	100 metric tons per hour
Removal Capacity Rocks (t/h)*	85 metric tons per hour
Unrestricted Diameter	200mm
Dimensions of Dredger L x W x H + Weight in Kg	3100mm x 350mm x 670mm 130 Kg
Dimensions of Transit Case L x W x H	2200mm x 850mm x 1000mm
Hydraulic Hoses Supplied	3 x Certified Hose's 3000mm Long c/w 8 JIC Female Swivel (6 JIC Case)

* Removal capacity is theoretical, removal rates will vary depending on the type of seabed being dredged.

The STS *Predator* MKI T-8 system is a completely new concept in performance dredging. Its unique features make it the most efficient dredger on the market saving both vessel and operational time.

The dredger can be easily mounted to the host ROV using its dedicated interface frame.

While optimum performance has always been a priority with this system, safety has also been a top priority. As such the *Predator* features certified lifting points and associated rigging and when placed on the deck the dredger sits upright on its integrated frame reducing the risk of manual handling injuries.

Optimum performance is achieved by utilising the latest fluid dynamic research.

The STS MKI T-8 can be assembled or disassembled subsea minimising ROV recovery time and increasing vessel productivity.



Subsea Tooling Services 10" MKI T10 ROV *Predator* Dredger



- Can be mounted to any Work Class ROV safely & quickly
- Certified lifting points & rigging
- Can be assembled / disassembled subsea by work class ROV / Diver
- Certified ROV mounting frame for fast mobilisation & on deck turnaround (optional)
- Can be configured for dredging or jetting subsea without need for ROV recovery (x 2 WROV required)
- Depth rated to 5000 MSW
- Optimum dredging up to 230mm rocks
- Comes with clay jetting nozzle & agitator as standard
- Optional lengths of suction / discharge hoses that can be changed out subsea
- Easily adapted to ROV or Diver use
- Can be converted to jetting mode subsea

Operational Specification

Hydraulic Flow	75– 90 Litres per minute
Optimal Hydraulic Pressure	190 – 210 Bar
Gross Water Flow	10000 Litres per minute (Through Ejector)
Removal Capacity Sand (t/h)*	120 metric tons per hour
Removal Capacity Rocks (t/h)*	35 metric tons per hour
Unrestricted Diameter	250mm
Dimensions of Dredger L x W x H x Weight in Air	2800mm x 450mm x 635mm (Height to top of lifting point) x 155 Kg
Dimensions of Transit Case L x W x H	2109mm x 840mm x 970mm
Hydraulic Hoses Supplied	3 x Certified Hose's 3000mm Long c/w 8 JIC Female Swivel (6 JIC Case)

* Removal capacity is theoretical, removal rates will vary depending on the type of seabed being dredged.

The STS *Predator* system is a completely new concept in performance dredging. Its unique features make it the most efficient dredger on the market saving both vessel and operational time.

The dredger can be easily mounted to the host ROV using its dedicated interface frame. While optimum performance has always been a priority with this system, safety has also been a top priority. As such the *Predator* features certified lifting points and associated rigging and when placed on the deck the dredger sits upright on its integrated frame reducing the risk of manual handling injuries & damage to the equipment.

Optimum performance is achieved by utilising the latest fluid dynamic research. The STS MKI T-10 can be assembled or disassembled subsea minimising ROV recovery time and increasing vessel productivity.

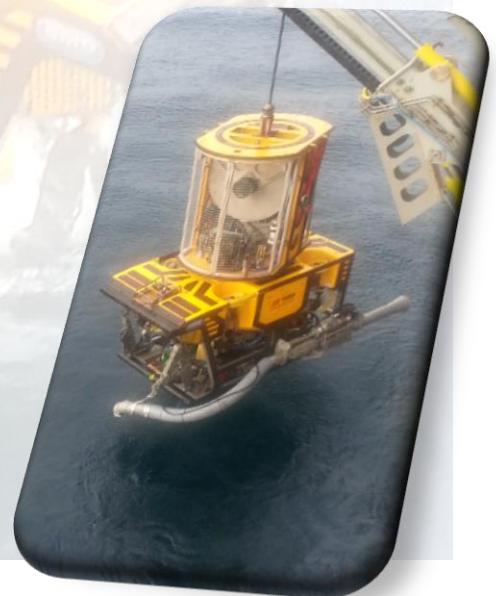
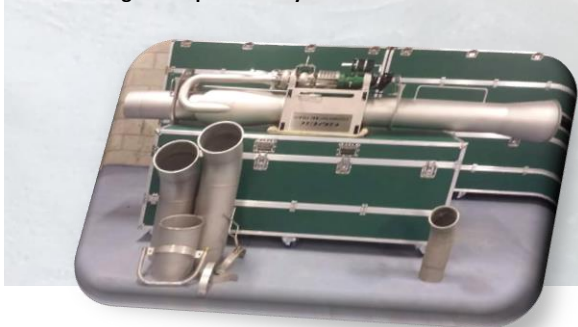

Subsea Tooling Services 12" MKI T12 *Titan* Mass Flow Dredger



- Can be deployed subsea on unique deployment frame
- Certified lifting points & rigging
- 360 Degree hydraulic actuated turn table for rapid suction nozzle re-positioning
- 4 x subsea deployable / retractable hydraulic stabilization legs that come with soft seabed anchor feet
- Comes with hydraulic back flush option
- Depth rated to 5000 MSW
- Optimum dredging up to 275mm rocks
- Optional lengths of suction / discharge hoses that can be changed out subsea
- Remote exhaust function for remote spoil dumping

Operational Specification

Hydraulic Flow	150 Litres per minute
Optimal Hydraulic Pressure	250 – 300 Bar
Gross Water Flow	16500 Litres per minute (Through Ejector)
Removal Capacity Sand (t/h)*	120 metric tons per hour
Removal Capacity Rocks (t/h)*	90 metric tons per hour ** Based on a rock size of 6 – 8" **
Unrestricted Diameter	300mm
Dimensions of Dredger L x W x H x weight in Kg	3000mm x 600mm x 800mm x 250 Kg
Dimensions of Deployment Frame L x W x H x weight in Kg	2500mm x 2500mm x 1500mm x 2500 Kg
Hydraulic Hose Reeler & Topside HPU	Optional

* Removal capacity is theoretical, removal rates will vary depending on the type of seabed being dredged.

The 12" Dredger system is designed to be deployed on its own unique dredge deployment frame, that acts as a platform for all dredging operations.

Once landed out the deployment frame can be hydraulically activated to deploy 4 x stabilization legs that will raise the deployment frame upwards and offer a stable platform to dredge from.

The 360 degree slew acts to aim the dredger towards to worksite and the exhaust in the opposite direction.

The dredger can be operated by either a hydraulic downline from the surface or direct from the ROV supply, provided it can provide the required flow / pressure.



Subsea Tooling Services 12" *Titan* Dredger Deployment Basket

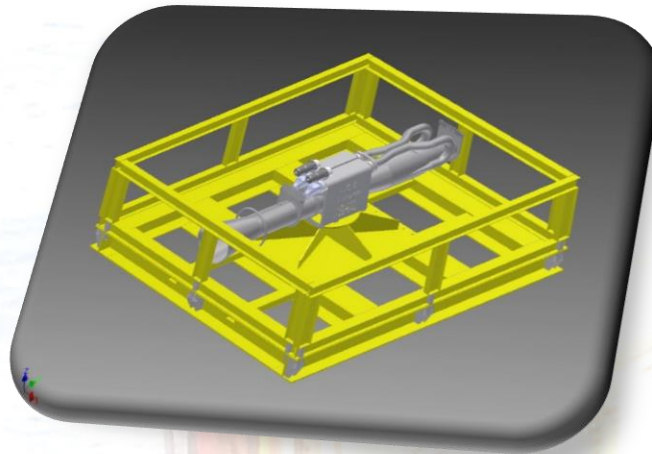

- Built in accordance with DNV 2.7-3
- Certified lifting points & rigging
- 360 Degree hydraulic actuated turn table for rapid suction nozzle re-positioning
- 4 x subsea deployable / retractable hydraulic stabilization sides that come with soft seabed anchor feet
- Depth compensated slew motor
- Depth rated to 5000 MSW
- Non slip grating on floor and sides
- Independent PO check valves fitted to all hydraulic cylinders for position holding & safe use
- Remote exhaust system can be deployed in basket

Operational Specification

External Dimensions L x W x H mm	3400mm x 3400m x 1315mm WIDE LOAD NOTIFICATION REQUIRED
Internal Dimensions L x W x H mm	3094mm x 3094mm x 1163mm
TARE Load	2500 Kg
Payload	5000 Kg
Max Gross Weight	7180 Kg
Depth Rating	5000 MSW
Certification Class	DNV 2.7-3
Lifting Height	5000mm

The Subsea Tooling Services 12" dredger deployment basket is the ideal solution to deploy the dredge system to depth. Not only does it keep all the dredger components safe during deployment, but it also offers a safe & stable working platform for the diver / ROV to deploy the dredger and use it efficiently.

To avoid moving the dredger around on the seabed, the dredger can be hydraulically orientated on the platform to face the work site. 4 hydraulic actuated sides fold down to offer stabilization and a large work platform for both divers & ROVs.

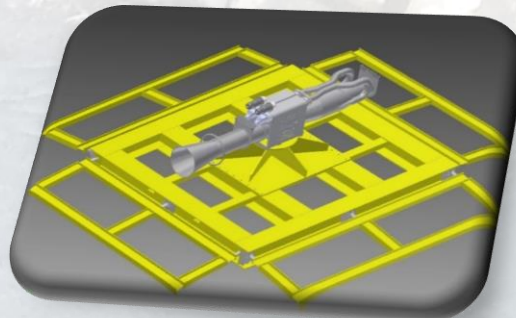

Subsea Tooling Services Seabed Saturation Lance



- Can be configured from dredging to jetting subsea
- No need for additional pumps as driven directly from a STS *Predator* dredger
- Can be deployed in a STS subsea basket and used as and when required
- ROV / Diver friendly handles
- 2" diameter water inlet
- 4 Bar pressure output @ 40,000 lph
- Rear T bar for maximum seabed penetration
- Comes with 2" 4000mm long water hose and dredger interface plate & exhaust blanking plate

Operational Specification

Dimensions L x W x H (mm)	1420mm x 150mm x 500mm
Water Inlet	2"
Gross Water Flow	7000 Litres per minute
Pressure	4 Bar
Dredger Interface	Subsea Connectable Horse Shoe Interface
Nozzle Diameter	40mm
Weight	50 Kg

The STS seabed saturation lance is the ideal tool for softening up heavy compacted seabed / drill cuttings.

The lance system can be used in conjunction with the STS range of *Predator* dredgers.

As the saturation lance utilises water flow from the dredger pump it means that no additional pumps need to be hired in to operate the lance.

The dredger can be reconfigured subsea from dredging mode to saturation lance mode without the need for ROV recovery.

All dredging / jetting components can be deployed & recovered in an STS subsea basket.



Subsea Tooling Services Diver / ROV Deployable Dredge Frame



- Can be deployed from vessel / rig moon pool
- Suction / exhaust hose can be connected subsea by diver / ROV
- Hydraulics can be supplied from a down line system or hot stab from the ROV
- No sharp edges to avoid injury to diver / ROV tether
- Certified 4 point lifting rigging with steel ferrules
- Built in accordance with DNV 2.7/3
- Comes with ROV / diver grab handles
- Comes with transponder bucket

Operational Description

Dimensions L x W x H	1470mm x 1675mm x 1400mm (to top of crash frame)
Weight	750 Kg (including dredger) up to 10"
Certification	Constructed in accordance with DNV 2.7/3
Dredger Interface	Compatible with all STS Predator dredgers from 4" to 10"
Rigging	4 x certified steel wire slings c/w steel ferrules
Safety Features	Non slip grating / Grab Handles
Diver Hydraulic Interface	Rear mounted panel with diver friendly butterfly connections
ROV Hydraulic Interface (Optional on Request)	Side mounted 3 port female hot stab receptacle c/w dummy stab.

The Subsea Tooling Services dredger deployment frame is ideal for deploying our dredgers safely to the sea floor.

This dredger deployment method can be used in conjunction with divers or work class ROVs.

As with all our *Predator* dredgers the suction hose & exhaust hose can be connected up to the dredger subsea simply by dropping the hose end connector into the connection flange and locking it there using the dredgers hose lock function.

Using this method of deployment saves attaching tools to the ROV, and keeps the work class ROVs free for other project specific purposes.

This system is also diver friendly and offers a rear mounted diver panel where the diver can hook up the hydraulic down lines from the surface.



Subsea Tooling Services Dredger Remote Spares Kit



Specification

- Spare Hydraulic Motor x 1
- Spare Dredge Pump Mechanical Seal x 1
- Spare Suction Hose Clamps x 2
- Spare Pump Seal Kit x 1
- Spare Operations Manual x 1
- Spare Hydraulic Hoses (Pressure / Return & Case Drain)

The Subsea Tooling Services Remote spares kit offers our clients the chance to carry out repairs to the STS dredger in remote locations. At Subsea Tooling Services we understand that sometimes things can go wrong with mechanical equipment, and the requirement to replace working parts cannot be avoided.

We offer a selective spares kit to dredge units going to remote global locations and as an optional extra for equipment in local areas also.