

PERFORMER 74

Profile system Gealan S8000 with 5 chambers

Profilsystem Gealan S8000 mit 5 Kammer
Sistema di profili Gealan S8000 con 5 camere
Sistemul de profile cu 5 camere Gealan S8000

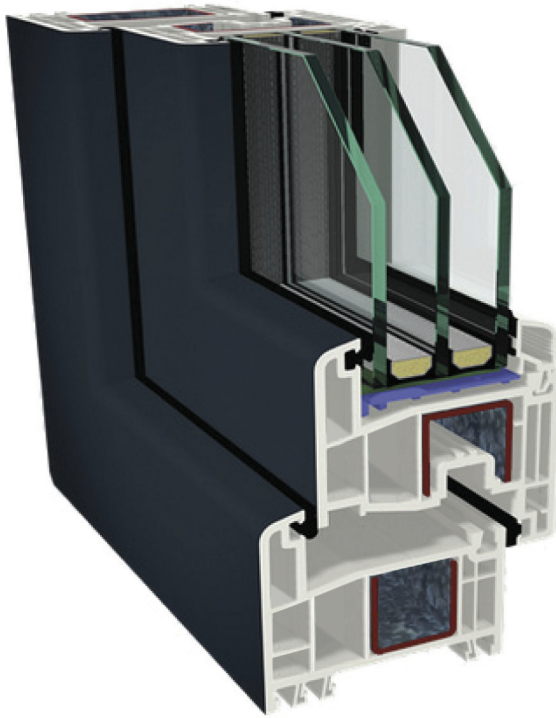

Profile System Manufacturer
Gealan Fenster-Systeme GmbH
Hofer Strasse 80, Oberkotzau
Deutschland



Heat transfer coefficient
Wärmedurchgangskoeffizient
Trasmittanza termica
Transmitanta termica

up to
bis
fino a
pana la $U_f = 1,2 \text{ W/(m}^2\text{K)}$



Resistance to wind load
Widerstandsfähigkeit
gegen Windlast
Resistenza ai carichi di vento
Rezistentă la încărcarea din vant

up to
bis
fino a
pana la Clasa C5/B5



**Tightness against driving rain -
unprotected (A)**
Schlagregendichtheit - Ungeschützt (A)
Tenuta all'acqua metodo di prova A
Etanșeitatea la apă
expunere directă

up to
bis
fino a
pana la 9A



Air permeability
Luftdurchlässigkeit
Tenuta all'aria
Permeabilitatea aerului

up to
bis
fino a
pana la Clasa 4



Sound insulation
Schallschutz
L'isolamento acustico
Izolarea acustică

up to
bis
fino a
pana la 47 dB



Burglar-resistant
Einbruchhemmung
Resistenza antieffrazione
Rezistentă antifracție

up to
bis
fino a
pana la RC 2 (WK 2)

System features / Systemmerkmale / Caratteristiche del sistema / Caracteristici Sistem

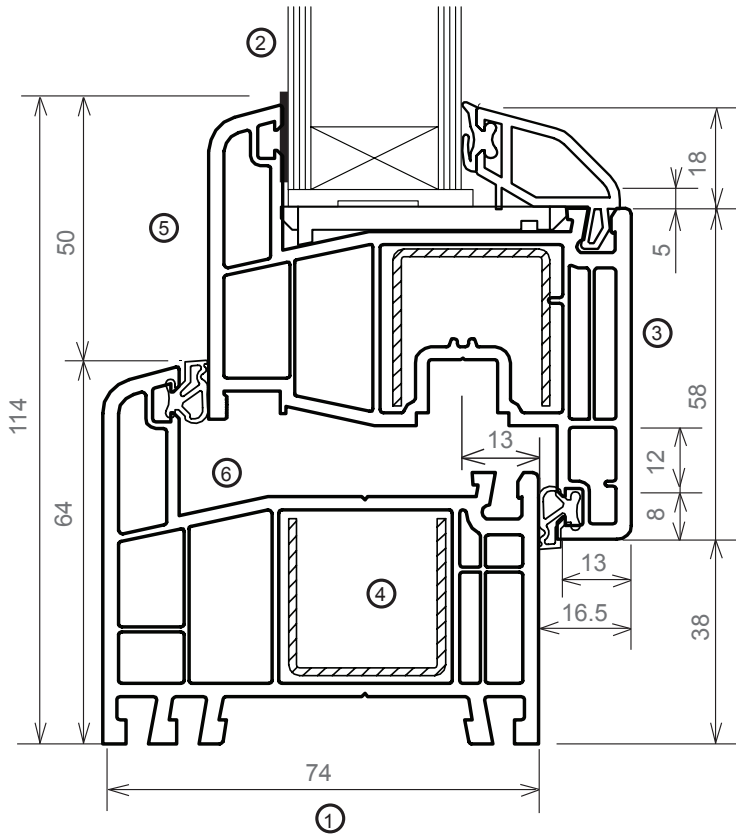

1. A construction depth of 74 mm ensures excellent heat and sound insulation
2. GEALAN-STV® is the ground-breaking system for bonding panes and casement, that delivers decisive benefits
3. Efficient use of material in the profile design saves resources and thus helps the environment
4. Very good rigidity due to large steel stiffeners in the frame and sash
5. Available in either flat profile with a bevelled glazing bead, or semiflush with round glazing beads
6. Easy to clean, thanks to a generously large sash rebate

- | | | |
|--|---|---|
| <p>GER</p> <ol style="list-style-type: none"> 1. 74 mm Bautiefe sorgen für gute Wärme- und Schalldämmung 2. GEALAN-STV® ist das bahnbrechende System, um Scheibe und Flügelüberschlag trocken zu verkleben 3. Materialoptimierte Profilgeometrie schont Ressourcen und damit die Umwelt 4. Gute Stabilität durch große Stahlstiefungen in Blendrahmen und Flügel 5. Klassische Linienführung der harmonisch abgestuften Außenansicht 6. Hohe Reinigungsfreundlichkeit durch groß dimensionierten Blendrahmenfalz | <p>ITL</p> <ol style="list-style-type: none"> 1. Profondità di costruzione del telaio 74 mm che assicura un'eccellente isolamento termico e acustico 2. STV® - GEALAN è il sistema rivoluzionario, di incollaggio a secco tra vetro e la battuta dell'anta che fornisce dei vantaggi notevoli 3. Uso efficiente dei materiali nella progettazione profilo consente di risparmiare risorse e, quindi, aiuta l'ambiente 4. Straordinaria stabilità grazie ai rinforzi utilizzati nel telaio e nell'anta 5. All'esterno del nodo ci sono due possibilità di scelta tra anta a sezione quadra o tonda 6. Facile da pulire con battuta battente di grandi dimensioni | <p>ROM</p> <ol style="list-style-type: none"> 1. Adancime de constructie de 74 mm pentru proprietati deosebite de izolare termica 2. Sistemul inovator GEALAN-STV® de lipire uscata a sticlei ofera multiple avantaje 3. Utilizare eficienta a materialelor in proiectarea profilului conserva resursele contribuind la protectia mediului 4. Stabilitate foarte buna datorita armaturii de otel groase din toc si cercevea 5. Design clasic fara varsta, cu baghete si cercevele rotunjite sau drepte 6. Usor de curatat datorita canalului de mari dimensiuni a tocului |
|--|---|---|

Color program / Dekorübersicht / Programma Colori / Program culori

Finishes	Color Shades	Laminated		Support material	Renolit Code	Gasket
		exterior	interior			
Dekore Pellicola Folie	Farbbezeichnung Colore Denumire culoare	Folierung Pellicolato Infoliere		Trägermaterial Colore Massa Material Bază	Renolit Code Codice Renolit Cod Renolit	Dichtung Guarnizione Garnitura
Wood grain / Holzdekore / Effetto Legno / Imitatie Lemn	Golden Oak	x	x	braun	9.2178001-116700	black
	Nussbaum V	x	x	braun	9.2178007-116700	black
Single Colors / Uni-Farben / Uni-culore / Culori Uni	Weiss	x	x	white	F456-5053	gray
	Cremeweiss	x	x	white	02.20.11.000001-116700	gray
	Anthrazitgrau	x	x	white	701605-116700	black



CENTRUM STAVEBNÍHO INŽENÝRSTVÍ a.s.
 (Building Engineering Centre, joint-stock company)
 Workplace in ZLÍN, K Cihelně 304, 764 32 ZLÍN - Louky

issues to

Applicant: GEALAN Fenster-Systeme GmbH
 Hofer Straße 80
 95145 Oberkotzau, Deutschland

CERTIFICATE

Of the product characteristic

No. CV – 15 – 772/Z

Product: The frame profiles of S 8000 IQ , PVC Tilt and Turn window (Pos. 2)

Manufacturer: See Applicant

Description:

Frame and sash	Frame 8032 00, 64 mm wide and 74 mm thick; frame reinforcement 8716 51, 1,5 mm thick; sash 8088 00, 76 mm wide and 74 mm thick; reinforcement 8716 51, 1,5 mm thick
Other profiles	glazing bead 7116 00 with extruded gasket
Insulating panel	Sandwich panel 35,8 mm thick: 1,5 mm PVC – 32,8 mm thermal insulation from hard foam - 1,5 mm PVC
Sealing	outer gasket 8186 92; inner gasket 8187 92; outer glazing gasket 8156 92
Hardware	All-Peripheral Hardware Siegenia TITAN AF, 6 point closure, 2 tilt and turn hinges, handle

Result:

Title of tested parameter	Testing method	Result
Thermal transmittance U_f	ČSN EN 12412-2	1,2 W/(m ² .K)

The result U_f fulfils the standard ČSN 73 0540, part 2 for recommended thermal transmittance:

$$U_f \leq U_{rec,20} = 1,3 \text{ W/(m}^2\text{.K)}$$

Background documents: Test report No. 311/15. CSI, a.s. Zlín, AO 212

This Certificate applies only for a product which its specification is given in the test report in detail. It certifies only above given properties and neither implies nor substitutes certification in accordance with the Law No. 22/1997 Coll. on technical requirements for products.

Issue date: 30.09.2015
Valid till: 30.09.2017
Elaborated by: Ing. Nizar Al-Hajjar



 Ing. Vladan Pánovec
 Workplace head

Nachweis
Energieeinsparung und Wärmeschutz

Prüfbericht 402 29298/2



Auftraggeber **GEALAN Fenster-
Systeme GmbH**
Hofer Straße 80

95145 Oberkotzau

Grundlagen
EN 12412-2 :2003-07
Bestimmung des
Wärmedurchgangskoeffizienten
mittels des
Heizkastenverfahrens, Teil 2:
Rahmen
Entspricht der nationalen
Fassung DIN EN .

Produkt	Flügel- / Blendrahmen - Profilkombination
Bezeichnung	S8000IQ
Bautiefe	Bautiefe Blendrahmen 74 mm Bautiefe Flügelrahmen 84,5 mm
Anstoßbreite	124 mm
Rahmenmaterial	PVC-U/weiß
Ausstattung	Stahl/verzinkt
Besonderheiten	—

Darstellung

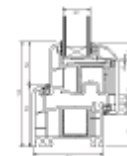

Verwendungshinweise

Dieser Prüfbericht dient zum
Nachweis des Wärmedurch-
gangskoeffizienten U_f

Gültigkeit

Die genannten Daten und
Ergebnisse beziehen sich
ausschließlich auf den
geprüften und beschriebenen
Gegenstand.

Die Prüfung des
Wärmedurchgangskoeffizienten
ermöglicht keine Aussage über
weitere leistungs- und
qualitätsbestimmenden
Eigenschaften der vorliegenden
Konstruktion.

Wärmedurchgangskoeffizient



$$U_f = 1,2 \text{ W}/(\text{m}^2 \cdot \text{K})$$



ift Rosenheim
8. Februar 2006

Ulrich Sieberath
Institutsleiter

L.A. Konrad Huber
Prüfchef Wärmeschutz &
Energietechnik

Veröffentlichungshinweise

Es gilt das ift-Merkblatt
„Hinweise zur Benutzung von
ift-Prüfberichten“.

Das Deckblatt kann als
Kurzfassung verwendet
werden.

Inhalt

Der Nachweis umfasst
insgesamt 5 Seiten

1. Gegenstand
2. Durchführung
3. Einzelergebnisse

02407/202



ift Rosenheim GmbH
Geschäftsführer:
Dipl.-Ing. (FH) Ulrich Sieberath
Dr. Jochen Pechl

Theodor-Greif-Straße 7-8
D-83026 Rosenheim
Tel. +49 (0) 9021 / 201-0
Fax +49 (0) 8031 / 201-290
www.ift-rosenheim.de

Str. 83026 Rosenheim
AG Traunstein, HRB 14763
Sparplatz Rosenheim
Kfz. 38 22
BLZ 711 500 00

Akreditierte Prüfstelle, Überwachungs-
und Zertifizierungsstelle
nach Landesbauordnung BAY 18
Notifizierung in Europa: Nr. 6757

Zusammenfassender Prüfbericht

Widerstandsfähigkeit bei Windlast,
Schlagregendichtheit, Luftdurchlässigkeit,
Bedienkräfte, Mechanische Beanspruchung,
Dauerfunktion, Tragfähigkeit von
Sicherheitsvorrichtungen, Stoßfestigkeit
Nr. 101 32802/Z



Auftraggeber **GEALAN
Fenster-Systeme GmbH
Hofer Str. 80**

Grundlagen

EN 14351-1 : 2006-03, Fenster
und Außentüren – Produktnorm

95145 Oberkotzau

Prüfnamen:

EN 1026 : 2000-06
EN 1027 : 2000-06
EN 12211 : 2000-06
EN 12046-1 : 2003-11
EN 14608 : 2004-03
EN 14609 : 2004-03
EN 1191 : 2000-02
RAL-RG 607/3
EN 13049 : 2003-08

Bauteil
Bezeichnung des
Systems

Fenster und Fenstertüren mit den Öffnungsarten:
Dreh, Drehkipp, Fest und zweiflügelig mit
aufgehendem Mittelstück

Rahmenmaterial **PVC-U/weiß**

Systembeschreibung **Auszug siehe Anlage 3**

Darstellung

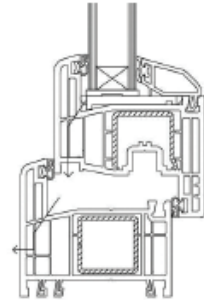

Besonderheiten **Profile gem. EN 12608, Klasse B (Wandstärke der Sicht
flächen $\geq 2,5$ mm, der nicht sichtbaren Flächen $\geq 2,0$ mm)**

Probekörper	1	2	3	
Darstellung				
Fenstergröße in mm	1396 x 2376	1032 x 2376	1864 x 1576	
Prüfung	Klassifizierung			
 EN 12210	Widerstands- fähigkeit bei Windlast	C5 / B5	C3 / B3	C4 / B4
 EN 12208	Schlagregen- dichtheit	9A	7A	8A
 EN 12207	Luftdurch- lässigkeit	4	4	4
 EN 13115	Bedienkräfte	1	1	1
 EN 13115	Mechanische Beanspruchung	4	4	4
 EN 12400	Dauerfunktion	2	2	2
 EN 13049	Stoßfestigkeit	2*		
		* Diese Eigenschaft wurde exemplarisch an Probekörper 2 geprüft		
 EN 13049	Tragfähigkeit von Sicherheitsvor- richtungen	Schwellenwert erfüllt	Schwellenwert erfüllt	Schwellenwert erfüllt
Falzhindernistest und Laibungstest nach RAL-RG 607/3 : 1995-02 Güte- und Prüfbestimmungen für Drehbeschläge und Drehkippbeschläge				Anforderung erfüllt

Verwendungshinweise

Dieser Prüfbericht dient zum
Nachweis der obengenannten
Eigenschaften für Fenster nach
EN 14351-1: 2006-3

Gültigkeit

Die Prüfergebnisse können
gemäß Übertragungsmatrix
(Punkt 2) übertragen werden.
Witterungs- und Alterungs-
erscheinungen wurden nicht be-
rücksichtigt.

Veröffentlichungshinweise

Es gilt das ift-Merkblatt „Bedin-
gungen und Hinweise zur Be-
nutzung von ift-Prüfdokumen-
tationen“.

Inhalt

Der zusammenfassende Prüf-
bericht umfasst insgesamt 29
Seiten.

- Anlage 1: Zugrundeliegende
Nachweise
- Anlage 2: Übertragungsmatrix
- Anlage 3: Auszug aus der
Systembeschreibung
- Anlage 4: Wichtige
Systemmerkmale

ift Rosenheim
14. Juni 2007

Jörn Peter Lass, Dipl.-Ing. (FH)
Prüfstellenleiter
ift Zentrum Fenster & Fassaden



ift Rosenheim GmbH
Geschäftsführer:
Dipl.-Ing. (FH) Ulrich Sieberath
Dr. Jochen Peichl

Theodor-Gietl-Str. 7 - 9
D-83026 Rosenheim
Tel. +49 (0)8031/251-0
Fax +49 (0)8031/281-290
www.ift-rosenheim.de

Robert Kolacny, Dipl.-Ing. (FH)
Prüfingenieur
ift Zentrum Fenster & Fassaden

Sitz: 83026 Rosenheim
AG Traunstein, HRB 14763
Sparkasse Rosenheim
Kto. 3822
BLZ 711 500 00

Notified Body Nr.: 0757
Anerkannte PUZ-Stelle: BAY 18
DAP-FL-0930-09
DAP-ZE-2390-00
TGA_Ze-18-08-00
TGA_Ze-18-08-00

Sound insulation test reports / Übersicht Schallprüfzeugnisse / Certificati d'isolamento acustico /
 Certificate izolare fonica

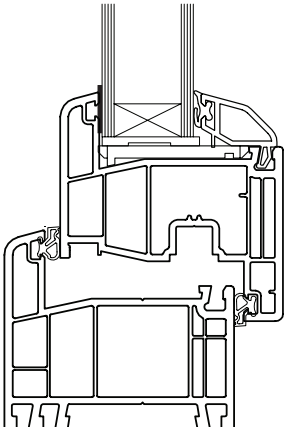
Element description Elementbeschreibung Descrizione elemento Descriere element	Pane structure (mm) Scheibenaufbau (mm) Struttura vetro (mm) Structura geam (mm)	Obtained values Rw.P=dB Erreichte Werte Rw.P=dB Valori raggiunti Rw.P=dB Valori obtinute Rw.P=dB
	4-16-4	34
	4-14-4-14-4	35
	6-16-4	38
	8-16-4	39
	6-14-4-14-4	40
	VSG 8-16-4	40
	VSG 10-16-4 (P4A)	40
	10-12-4-12-6	42
	VSG SI 6-16-6	43
	VSG SI 8-14-4-14-6	43
	VSG 10-12-4-16-6 (P4A)	43
	VSG SI 8-24-8	46
	VSG SI 8-12-4-12-8	45
	VSG SI 8-16-VSG SI 8	47
	VSG SI 10-16-VSG SI 8	47
	VSG SI 8-12-4-12- VSG SI 8	47

***VSG - Laminated glass / Verbundsicherheitsglas / Vetro stratificato / Sticla laminata**

***VSG SI - Acoustic laminated glass / Schallschutz-Verbundsicherheitsglas / Vetro stratificato acustico /**
 Sticla laminata cu control acustic

Symbol Legend / Symbol Legende / Legenda Simboli / Legenda simboluri

Window / Fenster /
Finestra / Fereastră

Window with mullion /
 Finster mit Pfosten /
Finestra con montante /
 Fereastră cu montant

Terrace door / Balkontüre
Porta balcone / Usa balcon

Door with sash rail /
 Tür mit Flügelsprosse /
Porta con traversa /
 Usa cu traversa

Residential Door / Haustüre
Portoncino / Usa intrare

Outswing door
 Außenöffnende Türen
Porta con apertura verso l'esterno
 Usa cu deschidere exterioara

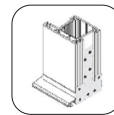
Renovation profile /
 Renovierungs-Blendrahmen /
Telaio ristrutturazione / Toc de
 renovare

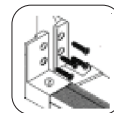
Threshold /
 Haustürschwelle /
Sotto soglia /
 Prag aluminiu

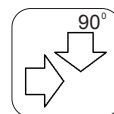
Window handle / Fenstergriff
Maniglia finestra / Maner fereastră

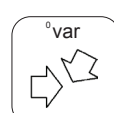
Threshold SLM /
 Haustürschwelle LFM /
Soglia in luce telaio /
 Prag montat in flat

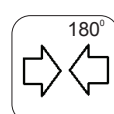
Double side door handle /
 Fenstergriffe mit Arretierung
Maniglia passante / Maner dublu

Coupling profiles 90 /
 Kopplungsprofile 90 /
Profili di accoppiamento 90 /
 Profile de cuplare 90

Door Handle / Drückergarnitur /
Maniglione / Maner usa

Variable bay pole /
 Variable Eckkopplung /
Giunto angolare variabile /
 Profile de cuplare unghi variabil

Flag door hinge / Haustürband /
Cerniera a bandiera / Balama usa

H coupler /
 H Schieber /
Profilo di accoppiamento /
 Profil cuplare

Door hinge RB / Haustürband RB /
Cerniera tubolare /
 Balama tubulara usa

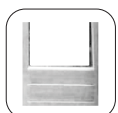
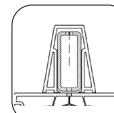
Outer frame extension /
 Blendrahmen Verbreiterung /
Allargatore Telaio /
 Profile extensie toc

Double hung window /
 Stulpfenster / *Finestra a due ante /*
 Fereastră in doua canate

Bank connection profile /
 Sohlbankprofile /
Profilo di appoggio inferiore /
 Profile suprainaltare pervaz

Extention profile /
 Höhenausgleichsprofil /
Zoccolo porta / Bandou usa

Reinforcing plant-on profile /
 Statik-Aufsatz /
Rinforzo /
 Ranforsare aplicată

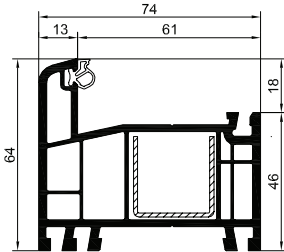
Frame profiles / Rahmenprofile / Profili Telaio / Profile Toc

Profile: 8032
Steel 8716
28.5x28.5 - 1.5 mm

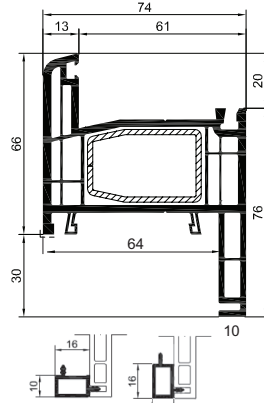

Profile: 8030
Steel 8701
43x27.5 - 2 mm



3297

Profile: 8027
Steel 8701
43x27.5 - 2 mm

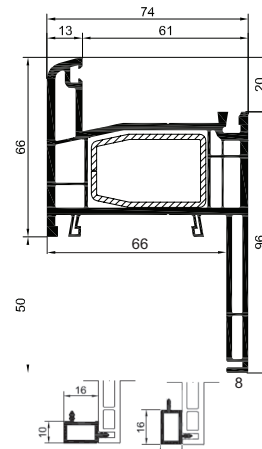
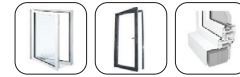

3297



Profilo	Forma irregolare		
8001	Alb	8001-Telaio a L 66mm	
8011	Alb	8010-Telaio a L 74mm	
8015	Alb	8015-Telaio a L 110mm Bianco	
8027	Alb	8027-Telaio a Z 50	
8030	Alb	8030-Telaio a Z 30	

Sash profiles / Flügelprofile / Profili Anta / Profile Cercevea

Profile: 8088
Steel 8716
28.5x28.5 - 1.5 mm

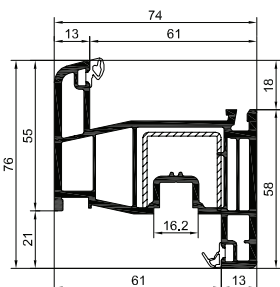
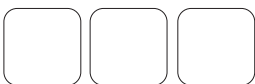

Profilo	Forma irregolare		
8001	Alb	8001-Telaio a L 66mm	
8011	Alb	8010-Telaio a L 74mm	
8015	Alb	8015-Telaio a L 110mm Bianco	
8027	Alb	8027-Telaio a Z 50	
8030	Alb	8030-Telaio a Z 30	

Sash rails & Floating mullion profiles / Pfosten & Stulpprofile / Profili per traverso & Profili per battuta centrale / Profile montant si Profile Stulp

Profile: 8080
Steel 8701
43x27.5 - 2 mm

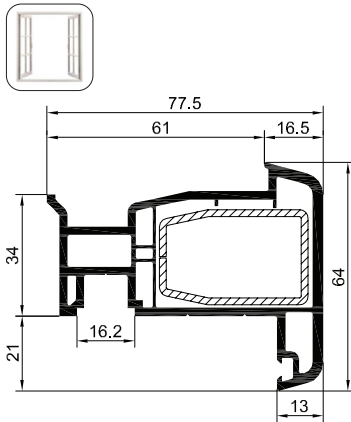

Profile: 8039
Steel 8701
43x27.5 - 2 mm

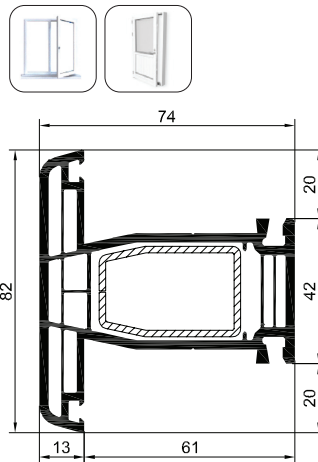

Profile: 8040
Steel 8713
49x34 - 2 mm

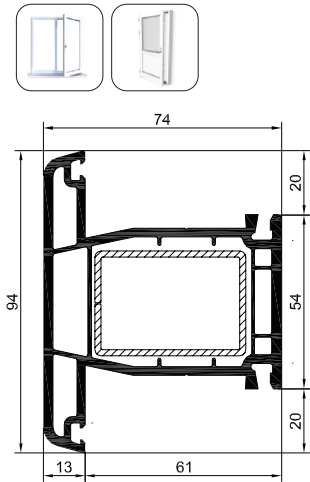

Dimens	mm	Particolari >>
▶ 8039	Alb	8039-Profilo montante 82mm
8040	Alb	8040-Profilo montante 94mm
8080	Alb	8080-Profilo di riporto 64mm
8273	Alb	Profilo riporto zoccolo 98mm, Bianco

Profile: 8273
Steel 8736

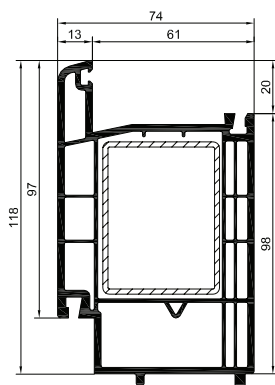

Threshold & Weather bar / Schwelle & Wetter Schenkel / Soglia & Profilo Gocciolatoio /
Praguri & Lacrimare

Profile: 6861501

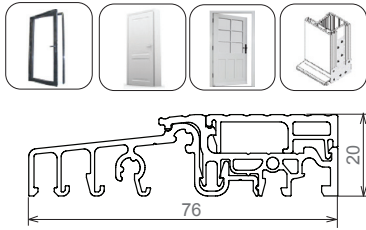

Profile: 259599

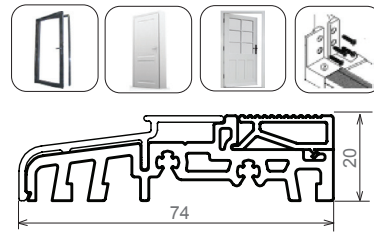

6861501	6861501 Soglia TT 20mm
6861501	6861501 Soglia TT 20mm con Guarnizione
8001	8001-Telaio a L 66mm
8001	8001-Telaio a L 66mm
8011	8010-Telaio a L 74mm
8011	8010-Telaio a L 74mm
8015	8015-Telaio a L 110mm Bianco
8015	8015-Telaio a L 110mm Bianco
8027	8027-Telaio a Z 50
8027	8027-Telaio a Z 50
8030	8030-Telaio a Z 30
8030	8030-Telaio a Z 30
FaraPrag	Senza Soglia

Profile: LC01



Gasket: 6802101



Coupling Profiles / Kopplungsprofile / Profili di accoppiamento / Profile cuplare

Profile: 500730

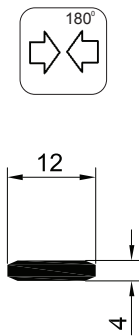

Profile: 7281

Steel 7796
 $I_x = 9,19 \text{ cm}^4$

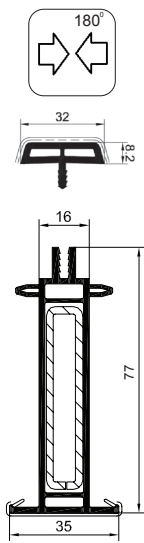

Profile: 2304

Steel 7718
 $I_x = 7,11 \text{ cm}^4$

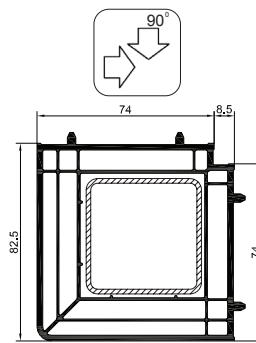

Profile: 2233

Steel 7711
 $I_x = 7,54 \text{ cm}^4$

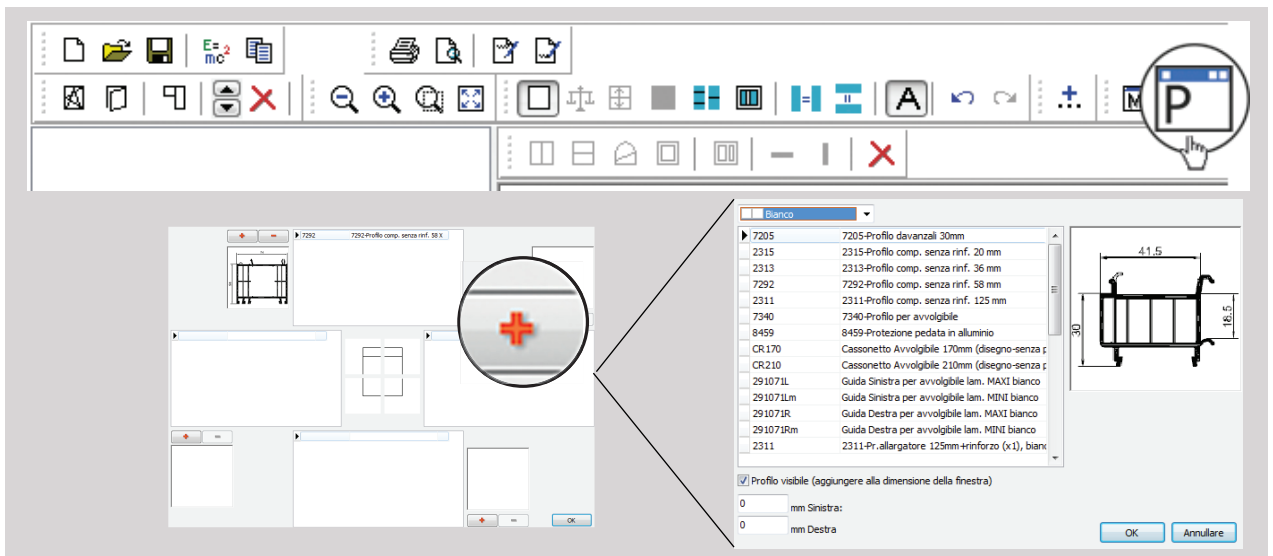
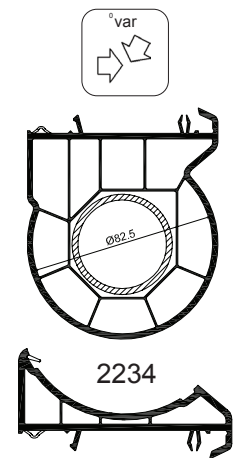

Bank connection profile / Bankanschluss profile / Profili di appoggio inferiore /

Profile suprainaltare

Profile: 3217

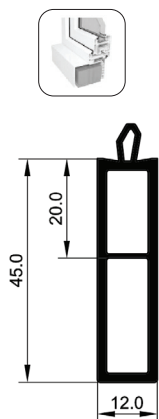

Profile: 7310

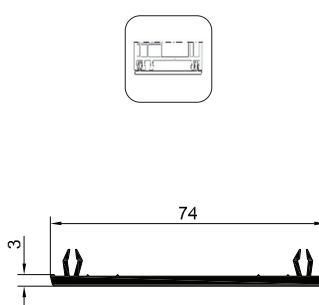

Profile: 7205

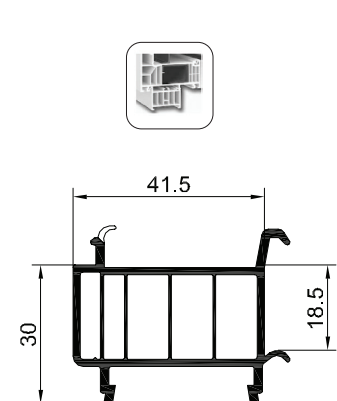

Extension profile / Verbreiterung profile / Allargatori / Extensii toc

Profile: 2315

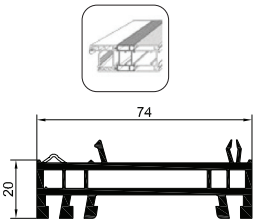

Profile: 2313
Steel 2724*
*Optional

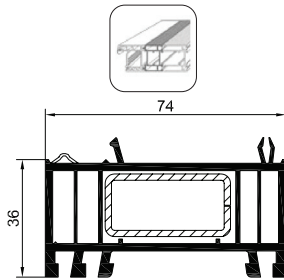

Profile: 7292
Steel 2724*
*Optional

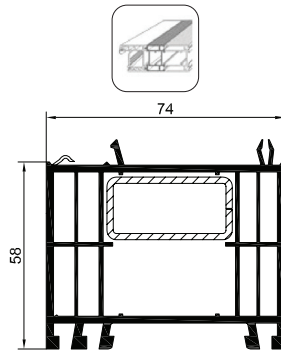

Profile: 2311
Steel 2724*
*Optional

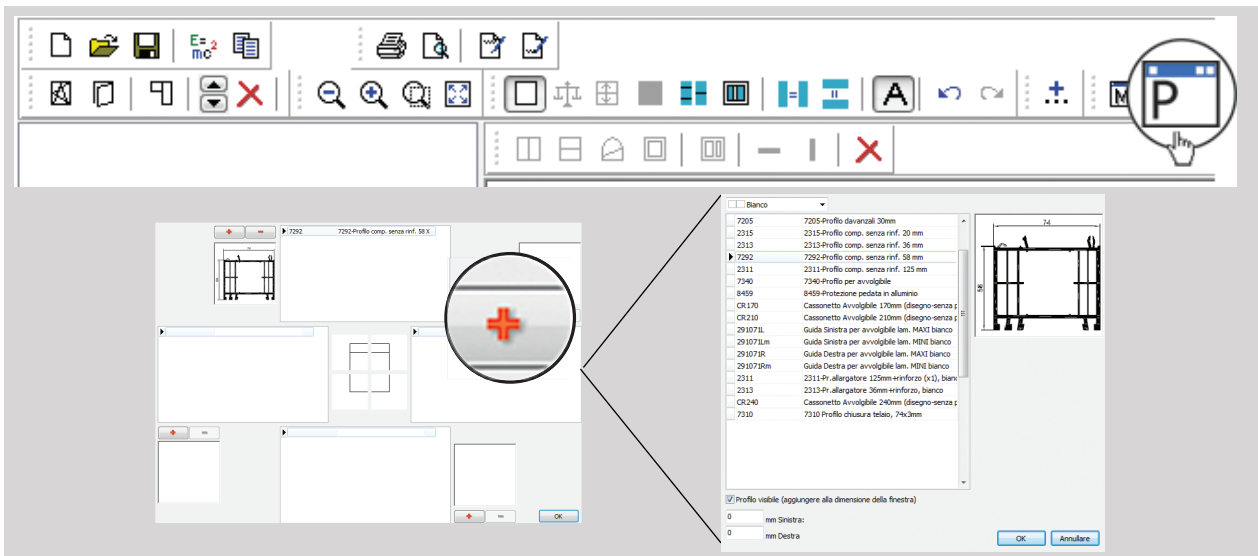
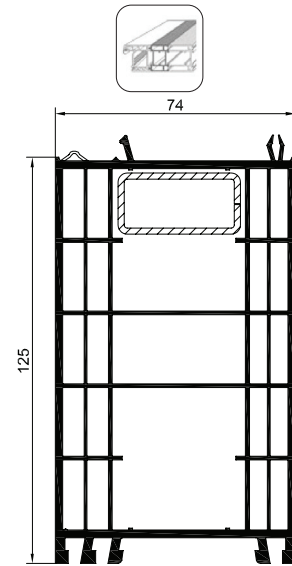

Gasket / Dichtung / Guarnizione / Garnitură

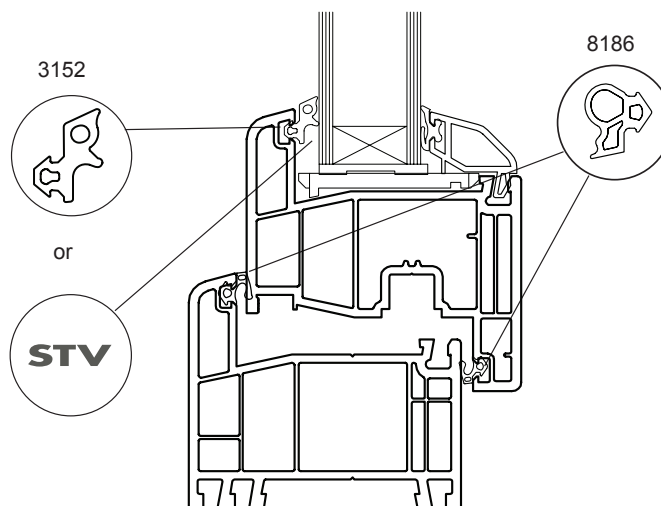

Fixed light / Festfeld / Fissa / Fix

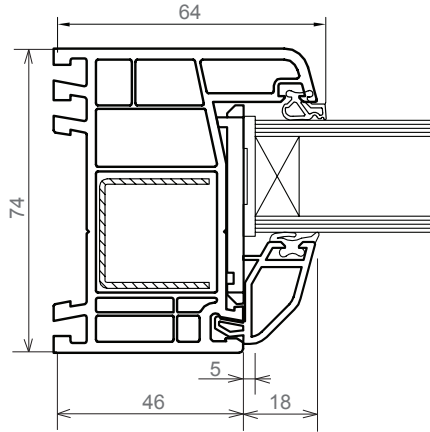
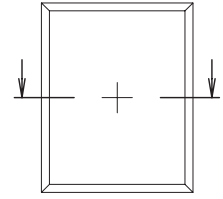

Frame Steel	8032	$I_x=1,74 \text{ cm}^4$ $I_y=1,05 \text{ cm}^4$
	8716	
	28.5x28.5 t=1.5mm	

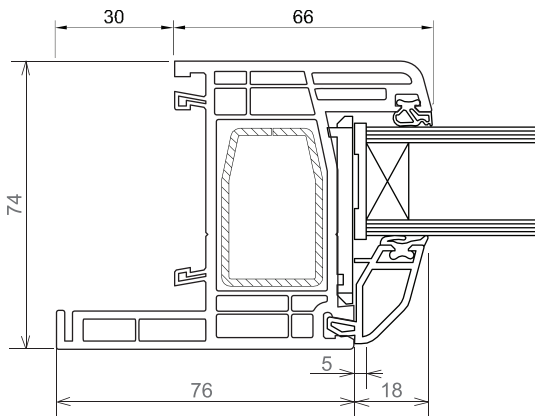

Frame Steel	8030	$I_x=5,92 \text{ cm}^4$ $I_y=2,87 \text{ cm}^4$
	8701	
	43x27.5 t= 2 mm	

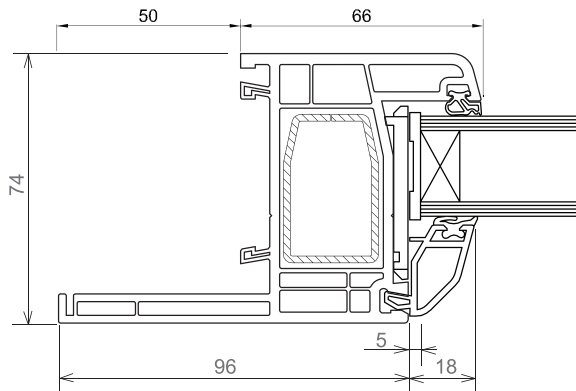

Frame Steel	8027	$I_x=5,92 \text{ cm}^4$ $I_y=2,87 \text{ cm}^4$
	8701	
	43x27.5 t= 2 mm	

Fixed light with transom / Festfeld Pfosten /
Fissa con montate / Fix cu montant

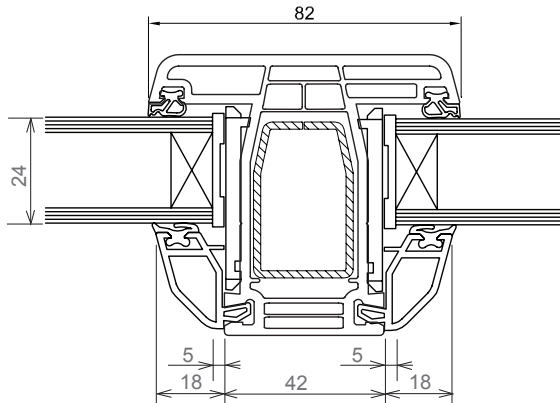
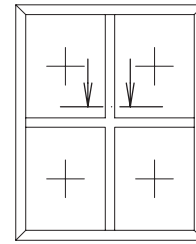

Transom	8039	$I_x=5,92 \text{ cm}^4$ $I_y=2,87 \text{ cm}^4$
Steel	8701	
	43x27.5	
	t = 2 mm	

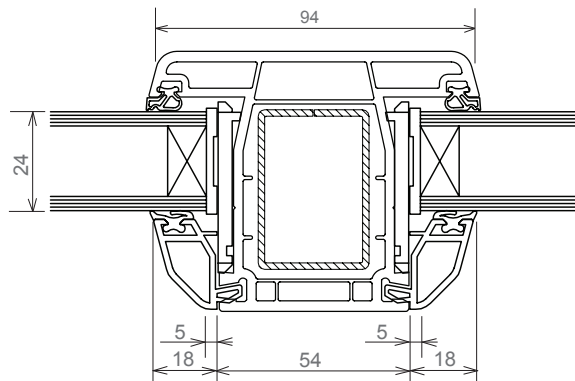

Transom	8040	$I_x=10,20 \text{ cm}^4$ $I_y=5,78 \text{ cm}^4$
Steel	8713	
	49x34	
	t = 2 mm	

Frame - Sash / Blendrahmen - Flügel /
Telaio - Anta / Toc - Cercevea

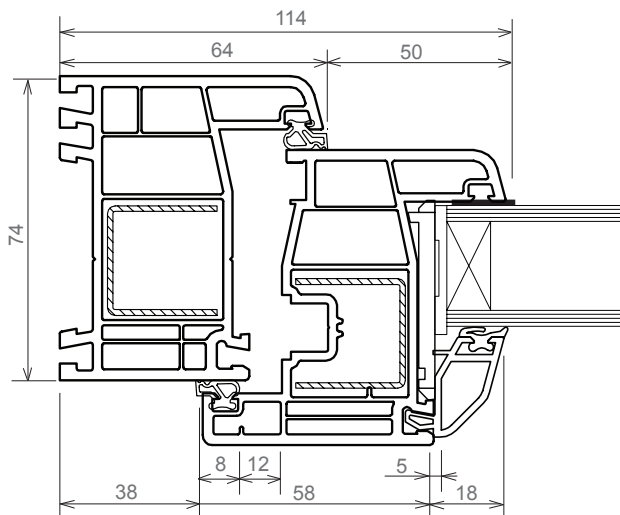
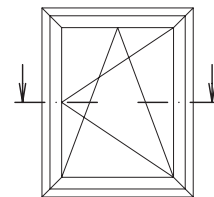

Frame	8032	$I_x=1,74 \text{ cm}^4$ $I_y=1,05 \text{ cm}^4$
Steel	8716	
	28.5x28.5 t=1.5 mm	
Sash	8088	$I_x=1,74 \text{ cm}^4$ $I_y=1,05 \text{ cm}^4$
Steel	8716	
	28.5x28.5 t=1.5 mm	

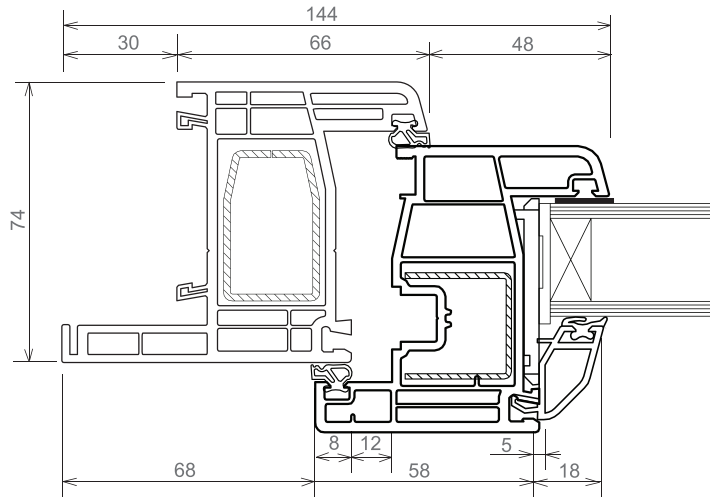

Frame	8030	$I_x=5,92 \text{ cm}^4$ $I_y=2,87 \text{ cm}^4$
Steel	8701 43x27.5 t=2 mm	
Sash	8088	$I_x=1,74 \text{ cm}^4$ $I_y=1,05 \text{ cm}^4$
Steel	8716 28.5x28.5 t=1.5 mm	

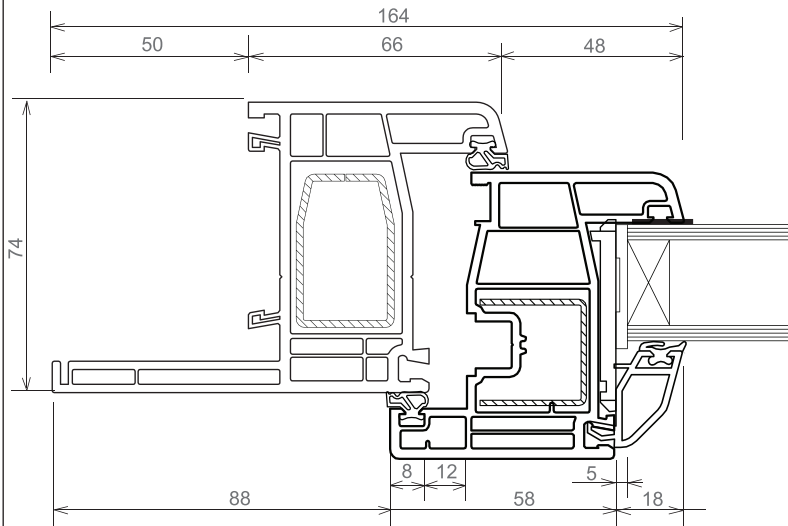

Frame	8027	$I_x=5,92 \text{ cm}^4$ $I_y=2,87 \text{ cm}^4$
Steel	8701 43x27.5 t=2 mm	
Sash	8088	$I_x=1,74 \text{ cm}^4$ $I_y=1,05 \text{ cm}^4$
Steel	8716 28.5x28.5 t=1.5 mm	

**Fixed light - Transom - Sash / Festfeld - Pfosten - Flügel /
Fisso - Montante - Anta / Fix - Montant - Cercevea**

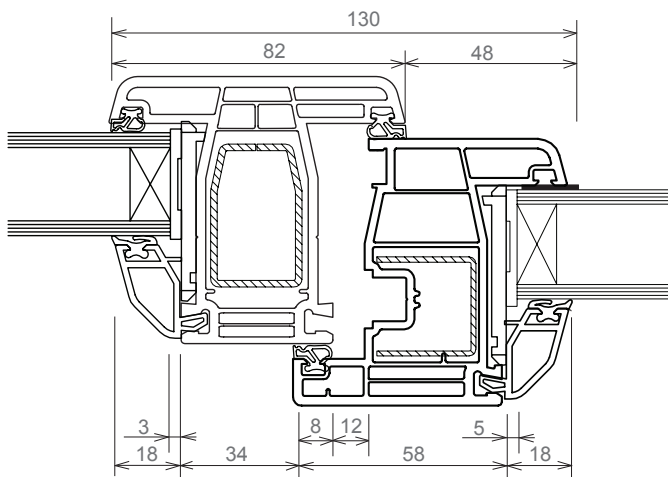
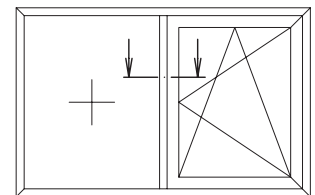

Transom	8039	$I_x=5,92 \text{ cm}^4$ $I_y=2,87 \text{ cm}^4$
Steel	8701 43x27.5 t=2 mm	
Sash	8088	$I_x=1,74 \text{ cm}^4$ $I_y=1,05 \text{ cm}^4$
Steel	8716 28.5x28.5 t=1.5 mm	

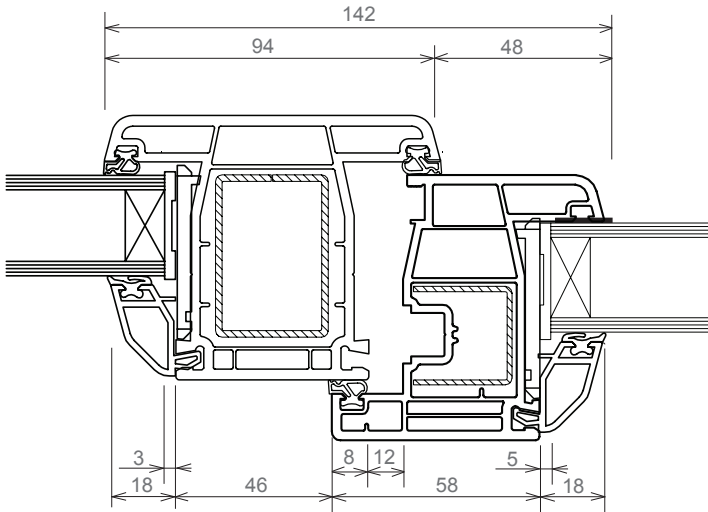

Transom	8040	
Steel	8713	$I_x=10,20 \text{ cm}^4$
	49x34	$I_y=5,78 \text{ cm}^4$
	t = 2 mm	
Sash	8088	
Steel	8716	$I_x=1,74 \text{ cm}^4$
	28.5x28.5	$I_y=1,05 \text{ cm}^4$
	t=1.5 mm	

Sash - Transom - Sash / Flügel Pfosten Flügel /
Anta - Montante Anta / Cercevea - Montant - Cercevea

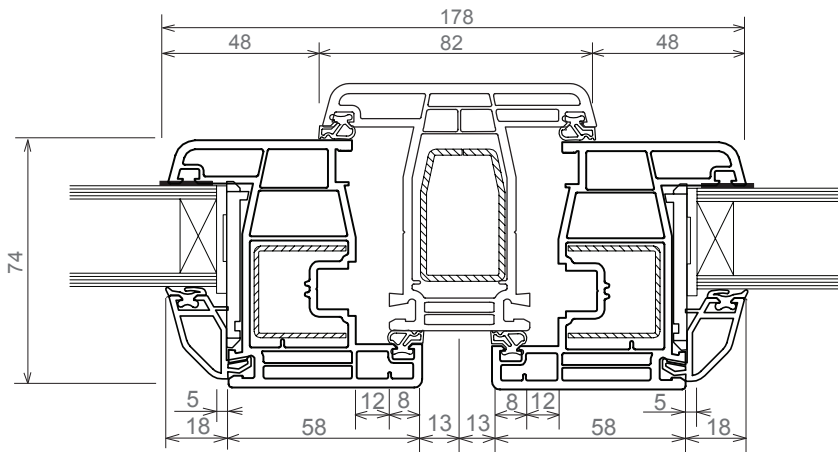
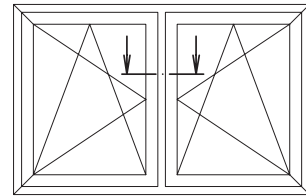

Sash	8088	
Steel	8716	$I_x=1,74 \text{ cm}^4$
		$I_y=1,05 \text{ cm}^4$
Transom	8039	
Steel	8701	$I_x=5,92 \text{ cm}^4$
	43x27.5	$I_y=2,87 \text{ cm}^4$
	t=2 mm	
Sash	8088	
Steel	8716	$I_x=1,74 \text{ cm}^4$
		$I_y=1,05 \text{ cm}^4$

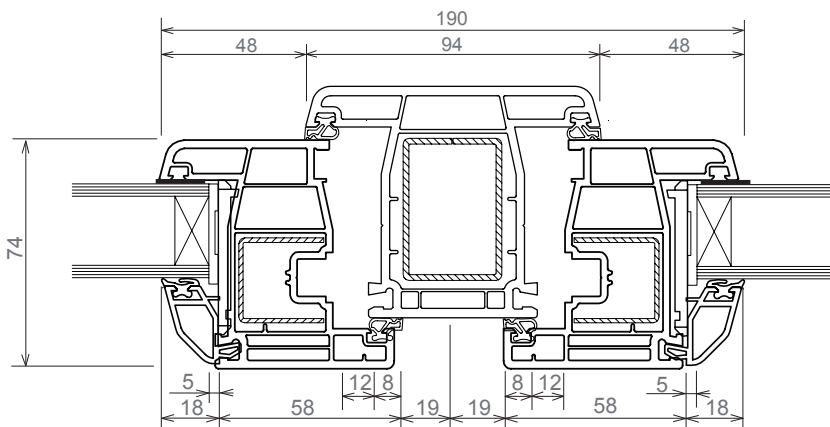

Sash	8088	
Steel	8716	$I_x=1,74 \text{ cm}^4$
		$I_y=1,05 \text{ cm}^4$
Transom	8040	
Steel	8713	$I_x=10,20 \text{ cm}^4$
	49x34	$I_y=5,78 \text{ cm}^4$
	t = 2 mm	
Sash	8088	
Steel	8716	$I_x=1,74 \text{ cm}^4$
		$I_y=1,05 \text{ cm}^4$

**Sash - Floating Mullion - Sash / Flügel - Stulp - Flügel /
Anta - Profilo Riporto - Anta / Cercevea - Ștulp - Cercevea**

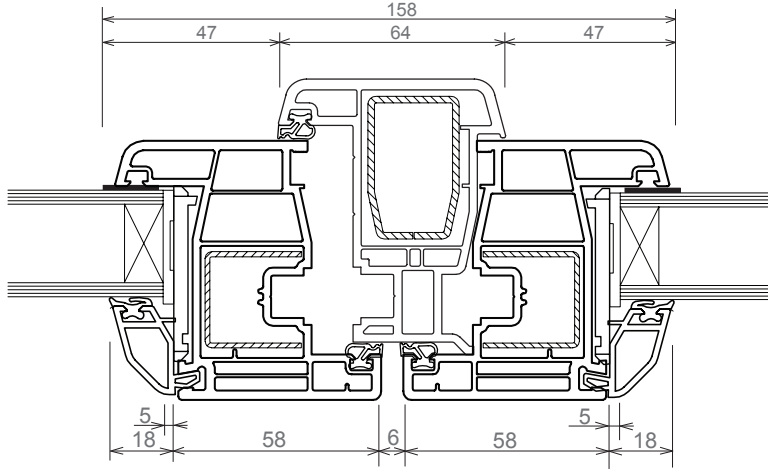
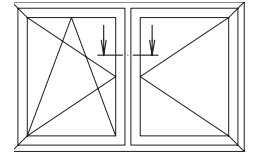

Sash Steel	8088 8716	$I_x=1,74 \text{ cm}^4$ $I_y=1,05 \text{ cm}^4$
Floating Mullion Steel	8080 8701 43x27.5 t=2 mm	$I_x=5,92 \text{ cm}^4$ $I_y=2,87 \text{ cm}^4$
Sash Steel	8088 8716	$I_x=1,74 \text{ cm}^4$ $I_y=1,05 \text{ cm}^4$

**Threshold - Sash / Schwellenprofil - Flügel /
Soglia - Anta / Prag - Cercevea**

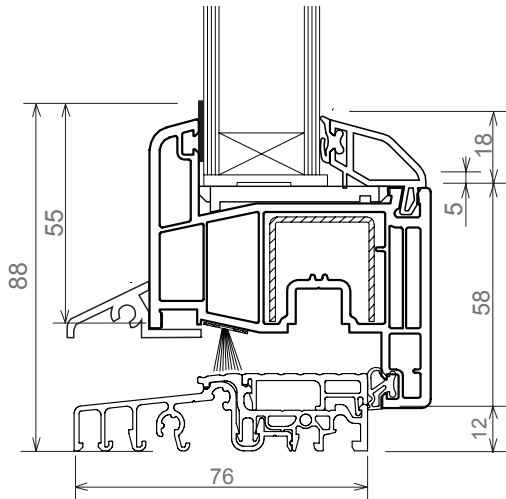
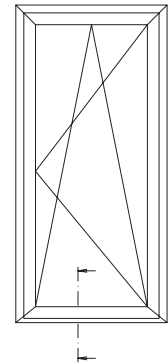

Threshold	6861501	
Sash Steel	8088 8716 28.5x28.5 t=1.5 mm	$I_x=1,74 \text{ cm}^4$ $I_y=1,05 \text{ cm}^4$

PERFORMER 74
RONDO
STYLE 76
PASIV 82
KUBUS
PREMIDOOR 76
PREMIDOOR 88
PREMILINE
BESCHLÄG
HARDWARE
GLAS
GLASS
ROLLO TOP
ROLLO FRONT
BORA
HERCULES 70

**Coupling profiles / Kopplungsprofile /
Profili di accoppiamento / Profile de cuplare**

Coupling profile gasket / Kopplungsdichtung / Guarnizione giunto / Garnitură de cuplare

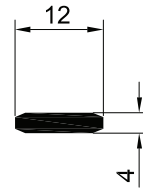
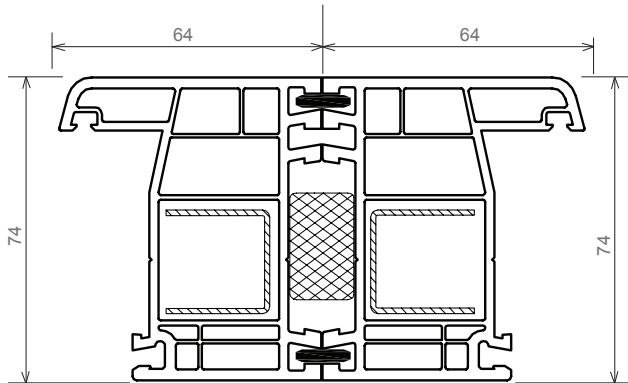

500730

H coupler / H Kopplung / Profilo di accoppiamento / Profil cuplare ranforsat

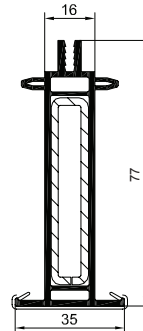
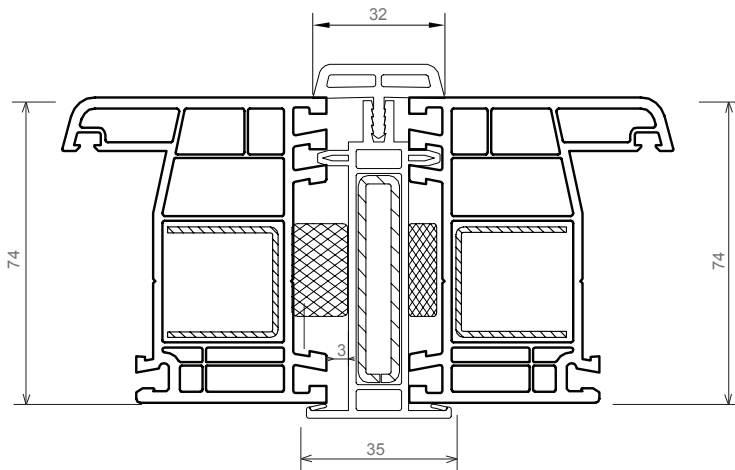

7281
Steel 7796
 $I_x=9,19\text{cm}^4$

**Corner coupling 90° / Eckkopplung 90° /
Giunto angolare 90° / Profil cuplare 90°**

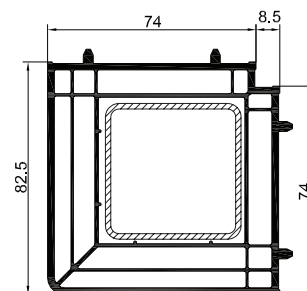
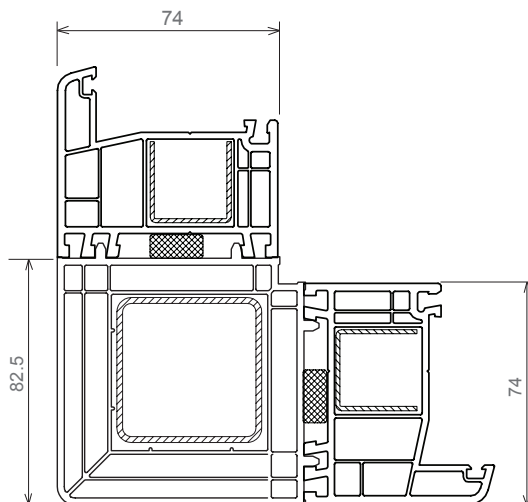

2304
Steel 7718
 $I_x=7,11\text{cm}^4$

Bay pole / Eckkopplung variabel / *Giunto angolare variabile* / Profil cuplare unghi variabil

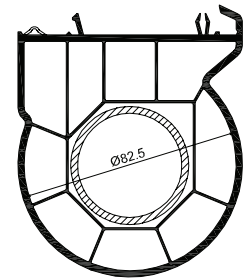
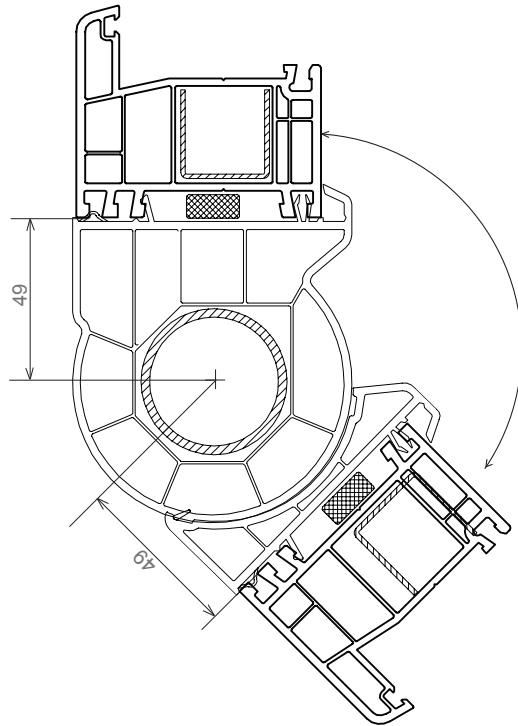

2233
Steel 7711
 $I_x = 7,54 \text{ cm}^4$

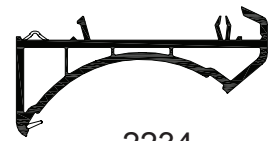

2234

Base profiles / Sohlbankprofile /
Profilo appoggio inferiore / Profile supraînălțare pervaz

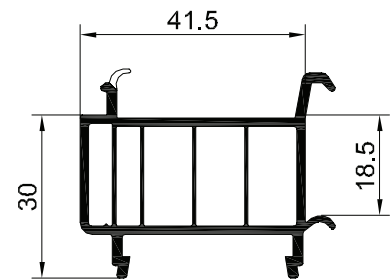
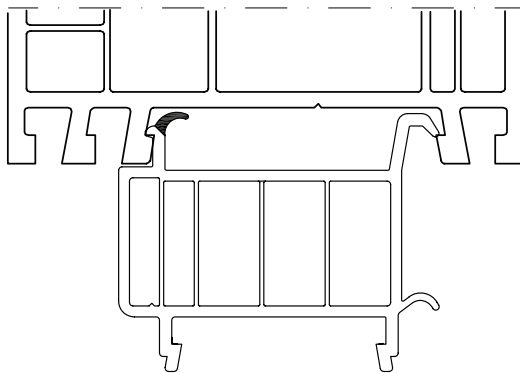

7205

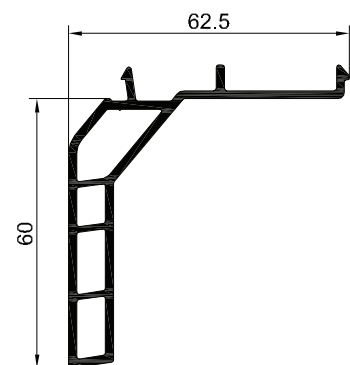
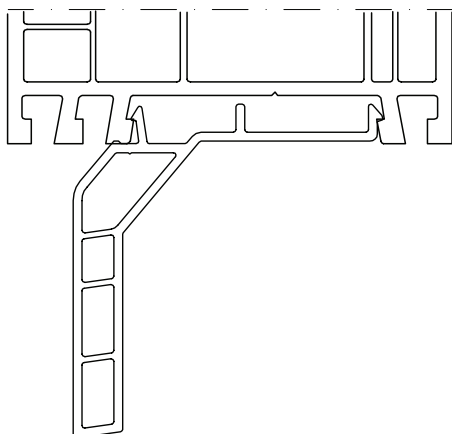

7209

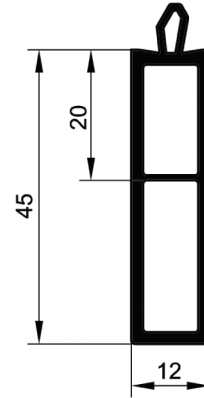
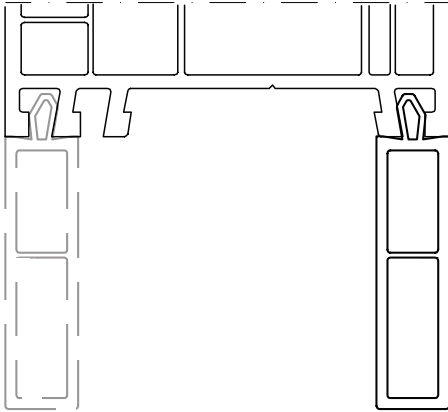

3217

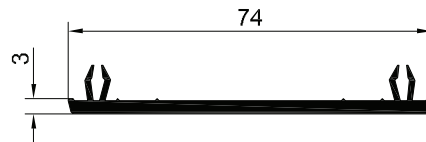
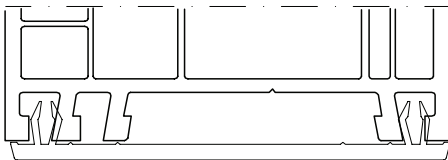

7310

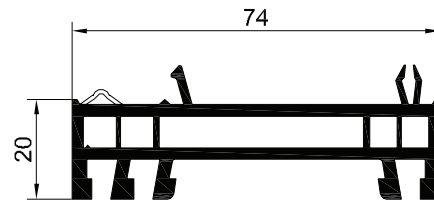
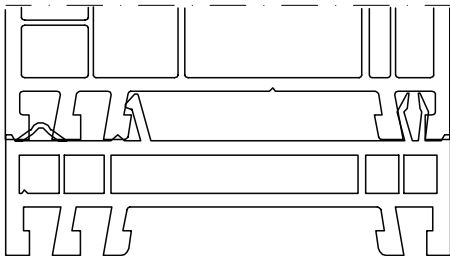

2315

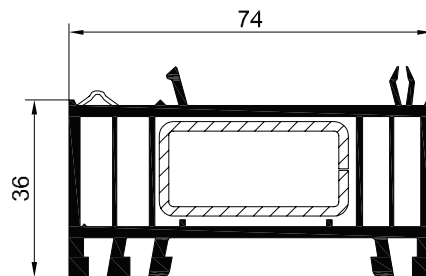
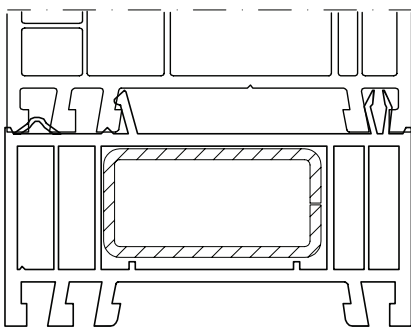

2313
Steel 2724*
*Optional

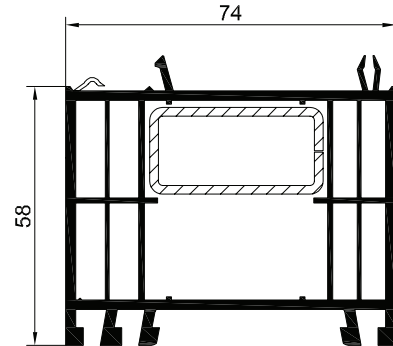
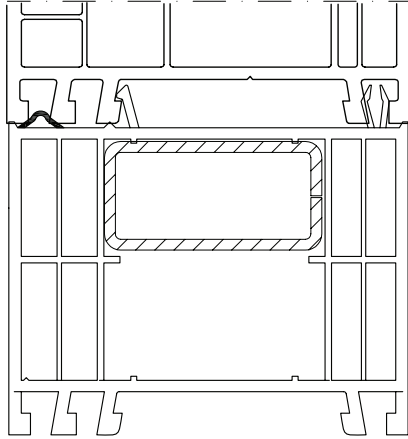

7292
Steel 2724*
*Optional

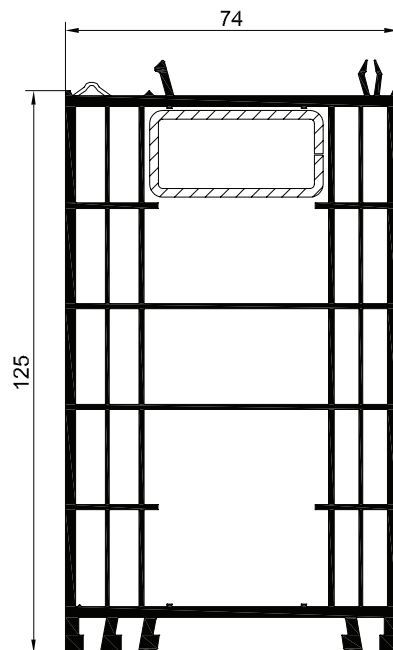
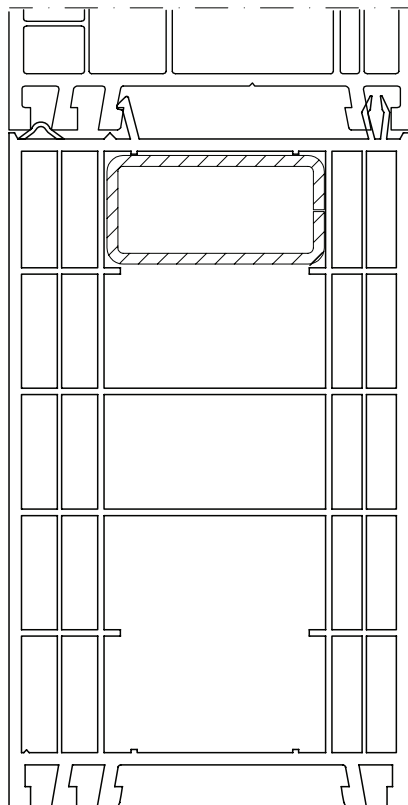

2311
Steel 2724*
*Optional

PERFORMER 74
RONDO
STYLE 76
PASIV 82
KUBUS
PREMIDOOR 76
PREMIDOOR 88
PREMILINE
BESCHLÄG
HARDWARE
GLASS
GLASS
ROLLO TOP
ROLLO FRONT
BORA
HERCULES 70

Window Sash Maximum Sizes / Fenster Flügelgrößen Diagramme /
Campi d'applicazione Anta Finestra / Dimensiuni maxime cercevea fereastră

Opening types

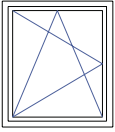

Profile: **WHITE** / WEISS / BIANCO / ALB

Glass: $\leq 30 \text{ kg/m}^2$

Sash: Standard

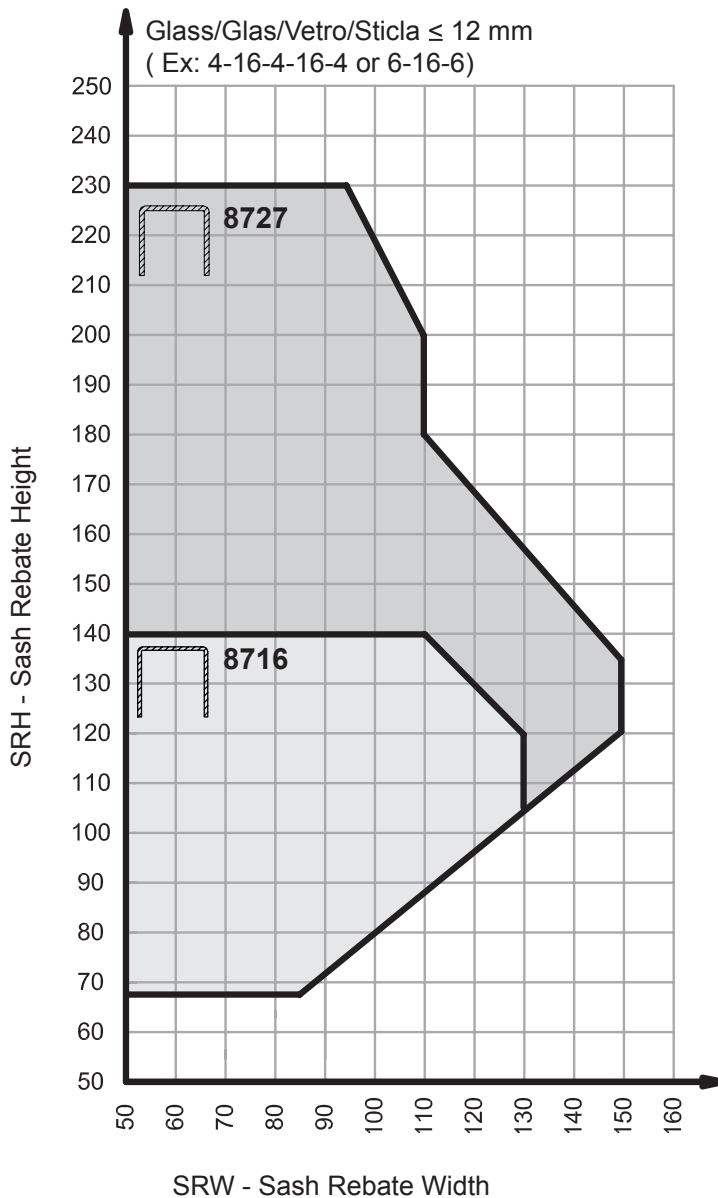

Steel

8727

28.5x28.5 $I_x=2,20 \text{ cm}^4$
t=2 mm

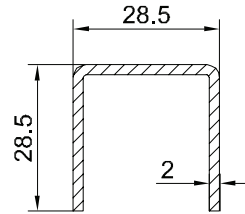

Steel

8716

28.5x28.5 $I_x=1,74 \text{ cm}^4$
t=1.5 mm

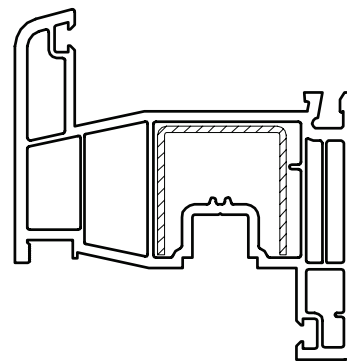
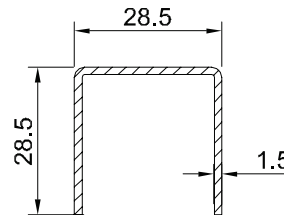

Sash 8088

The sash width must not be greater than the sash height by more than 25%

Die Flügelbreite darf die Flügelhöhe um nicht um mehr als 25% überschreiten.

La larghezza dell'anta non deve superare l'altezza della medesima di oltre il 25%

Lățimea cercevelei nu trebuie să depășească înălțimea acesteia cu mai mult de 25%

Window Sash Maximum Sizes / Fenster Flügelgrößen Diagramme /
Campi d'applicazione Anta Finestra / Dimensiuni maxime cercevea fereastră

Opening types

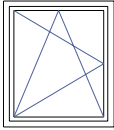

Profile: **WHITE / WEISS / BIANCO / ALB**

Glass: $\leq 30 \text{ kg/m}^2$

Sash: STV

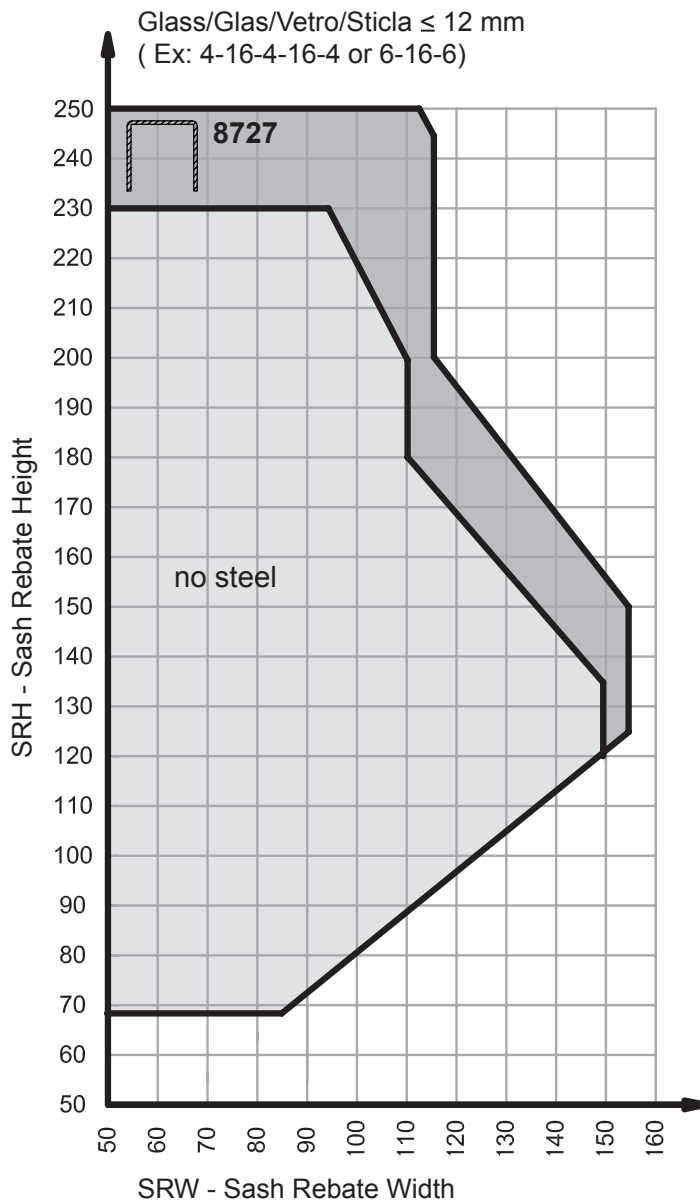

Steel

8727

28.5x28.5 $I_x=2,20 \text{ cm}^4$
t=2 mm

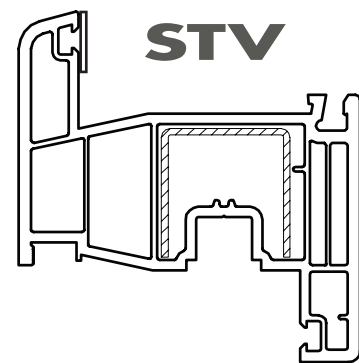
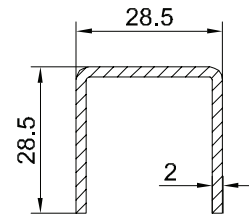

Sash 8088A

The sash width must not be greater than the sash height by more than 25%

Die Flügelbreite darf die Flügelhöhe um nicht um mehr als 25% überschreiten.

La larghezza dell'anta non deve superare l'altezza della medesima di oltre il 25%

Lățimea cercevelei nu trebuie să depășească înălțimea acesteia cu mai mult de 25%

Window Sash Maximum Sizes / Fenster Flügelgrößen Diagramme /
Campi d'applicazione Anta Finestra / Dimensiuni maxime cercevea fereastră

Opening types

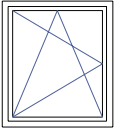

Profile: **COLOR / FARBE / PELLICOLATO / COLOR**

Glass: $\leq 30 \text{ kg/m}^2$

Sash: Standard

Steel

8727

28.5x28.5 $I_x=2,20 \text{ cm}^4$
t=2 mm

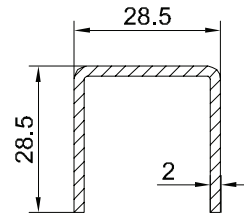

Steel

8716

28.5x28.5 $I_x=1,74 \text{ cm}^4$
t=1.5 mm

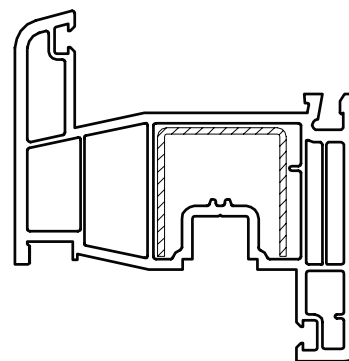
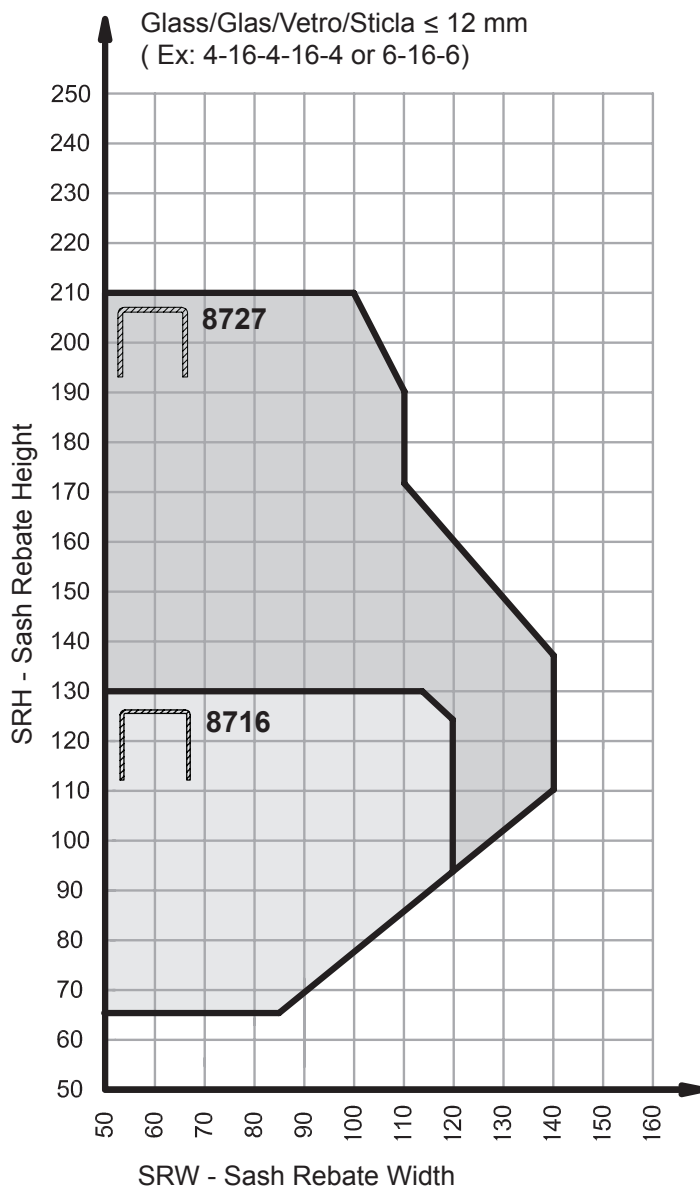
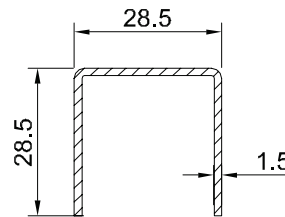

Sash 8088

The sash width must not be greater than the sash height by more than 25%

Die Flügelbreite darf die Flügelhöhe um nicht um mehr als 25% überschreiten.

La larghezza dell'anta non deve superare l'altezza della medesima di oltre il 25%

Lățimea cercevelei nu trebuie să depășească înălțimea acesteia cu mai mult de 25%

Window Sash Maximum Sizes / Fenster Flügelgrößen Diagramme /
Campi d'applicazione Anta Finestra / Dimensiuni maxime cercevea fereastră

Opening types

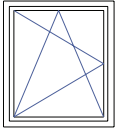

Profile: **COLOR / FARBE / PELLICOLATO / COLOR**

Glass: $\leq 30 \text{ kg/m}^2$

Sash: STV

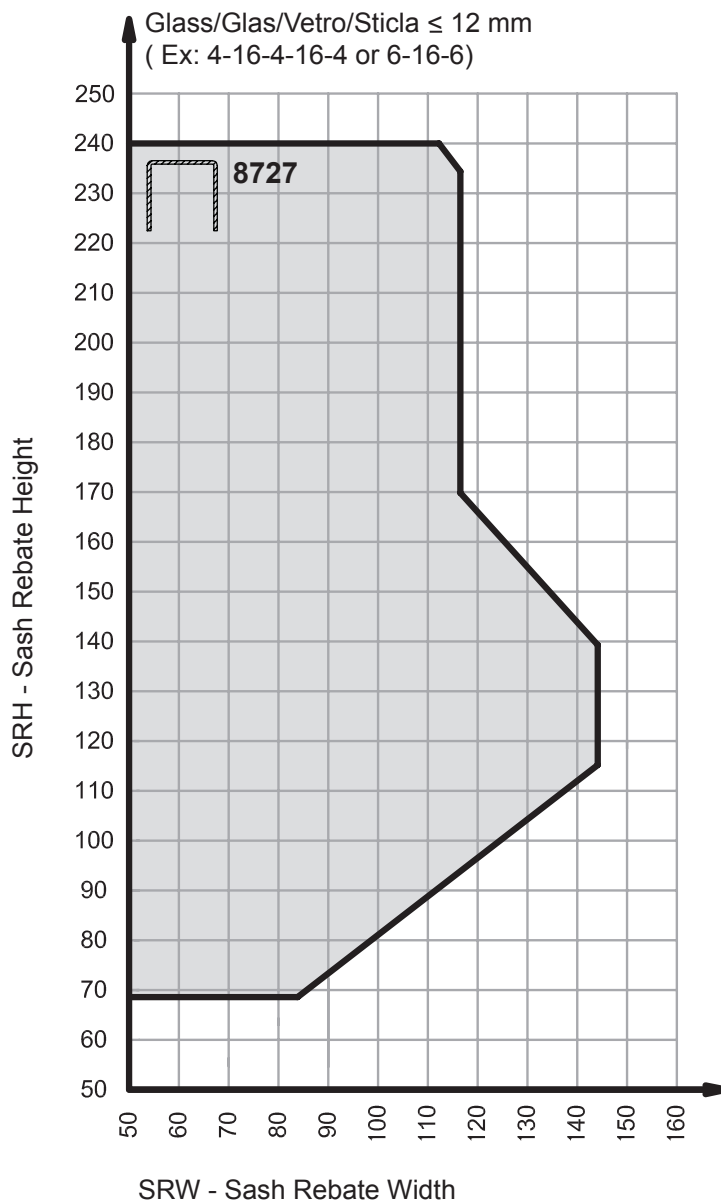

Steel

8727

28.5x28.5 $I_x=2,20 \text{ cm}^4$
 $t=2 \text{ mm}$

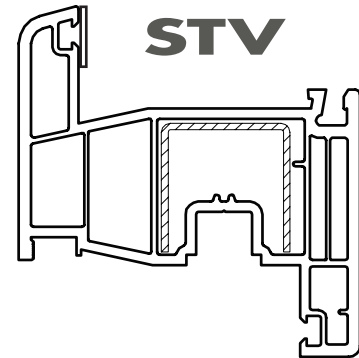
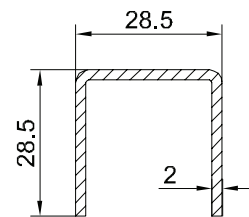

Sash 8088A

The sash width must not be greater than the sash height by more than 25%

Die Flügelbreite darf die Flügelhöhe um nicht um mehr als 25% überschreiten.

La larghezza dell'anta non deve superare l'altezza della medesima di oltre il 25%

Lățimea cercevelei nu trebuie să depășească înălțimea acesteia cu mai mult de 25%

Window Sash Maximum Sizes / Fenster Flügelgrößen Diagramme /
Campi d'applicazione Anta Finestra / Dimensiuni maxime cercevea fereastră

Opening types

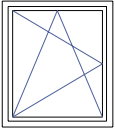

Profile: **WHITE and COLOR** / WEISS und FARBE /
BIANCO e PELLICOLATO / ALB si COLOR
Glass: $\leq 50 \text{ kg/m}^2$
Sash: Standard

Steel

8727
28.5x28.5 $I_x=2,20 \text{ cm}^4$
t=2 mm

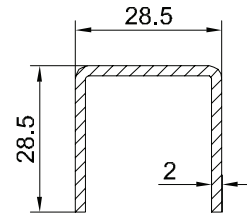

Steel

8716
28.5x28.5 $I_x=1,74 \text{ cm}^4$
t=1.5 mm

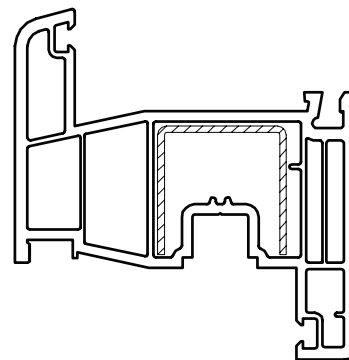
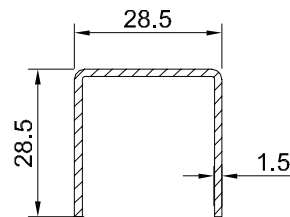

Sash 8088

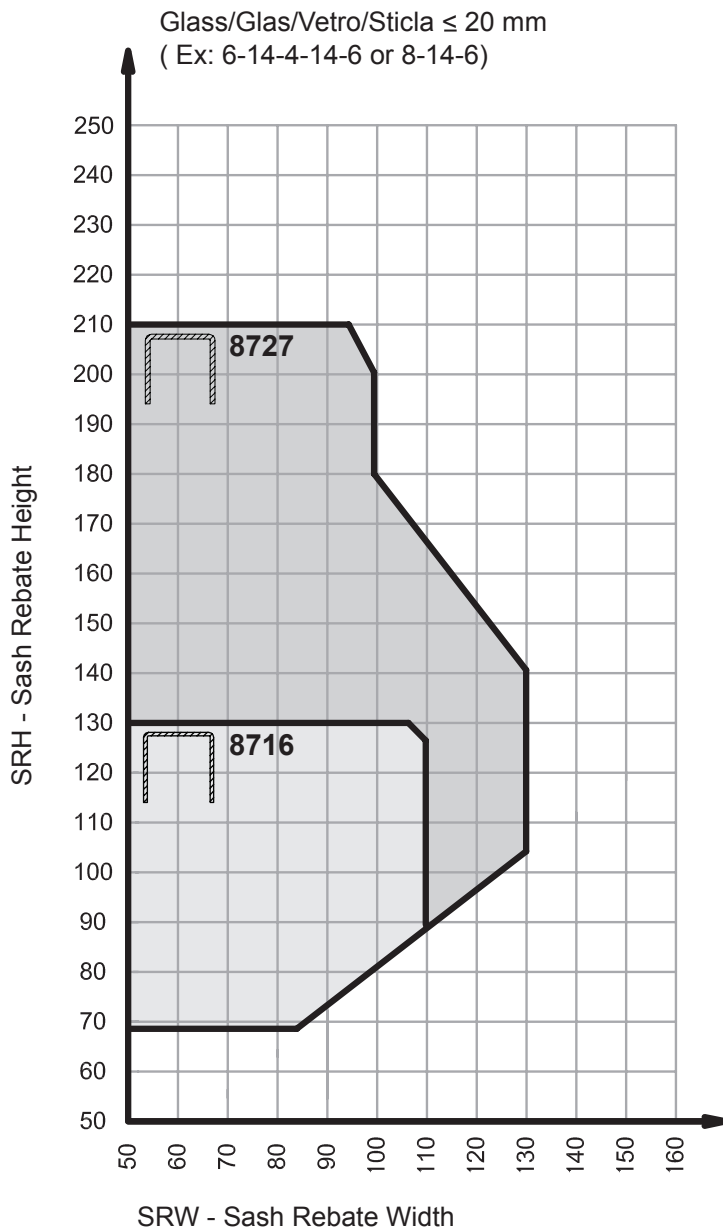

The sash width must not be greater than the sash height by more than 25%

Die Flügelbreite darf die Flügelhöhe um nicht um mehr als 25% überschreiten.

La larghezza dell'anta non deve superare l'altezza della medesima di oltre il 25%

Lățimea cercevelei nu trebuie să depășească înălțimea acesteia cu mai mult de 25%

Window Sash Maximum Sizes / Fenster Flügelgrößen Diagramme /
Campi d'applicazione Anta Finestra / Dimensiuni maxime cercevea fereastră

Opening types

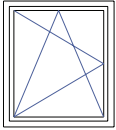

Profile: **WHITE** and **COLOR** / WEISS und FARBE /
BIANCO e PELLICOLATO / ALB si COLOR
Glass: $\leq 50 \text{ kg/m}^2$
Sash: STV

Steel

8727
28.5x28.5 $I_x=2,20 \text{ cm}^4$
t=2 mm

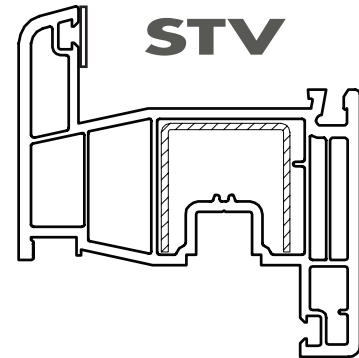
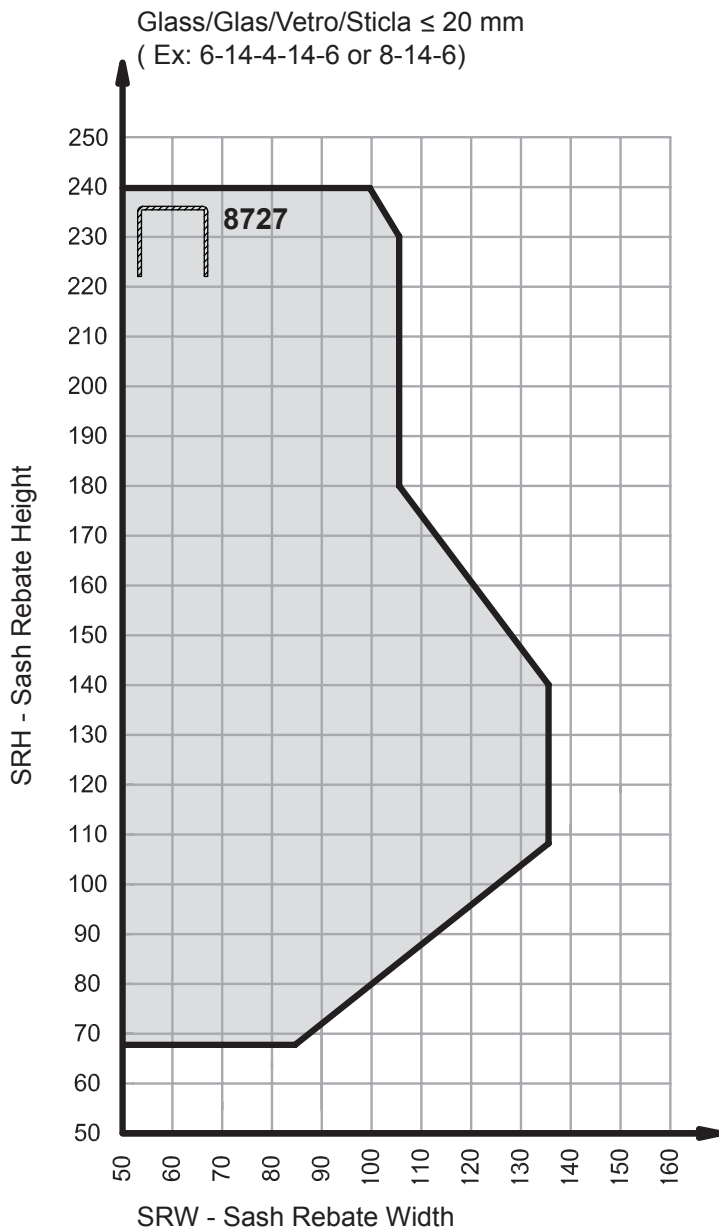
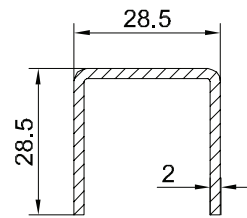

Sash 8088A

The sash width must not be greater than the sash height by more than 25%

Die Flügelbreite darf die Flügelhöhe um nicht um mehr als 25% überschreiten.

La larghezza dell'anta non deve superare l'altezza della medesima di oltre il 25%

Lățimea cercevelei nu trebuie să depășească înălțimea acesteia cu mai mult de 25%

Window Sash Maximum Sizes / Fenster Flügelgrößen Diagramme /
Campi d'applicazione Anta Finestra / Dimensiuni maxime cercevea fereastră

Opening types

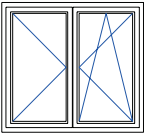

Profile: **WHITE** / WEISS / BIANCO / ALB

Glass: $\leq 30 \text{ kg/m}^2$

Sash: Standard

Steel

8727

28.5x28.5 $I_x=2,20 \text{ cm}^4$
t=2 mm

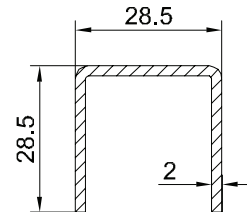

Steel

8716

28.5x28.5 $I_x=1,74 \text{ cm}^4$
t=1.5 mm

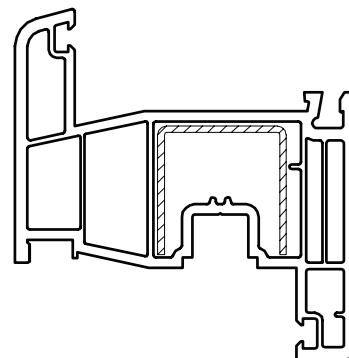
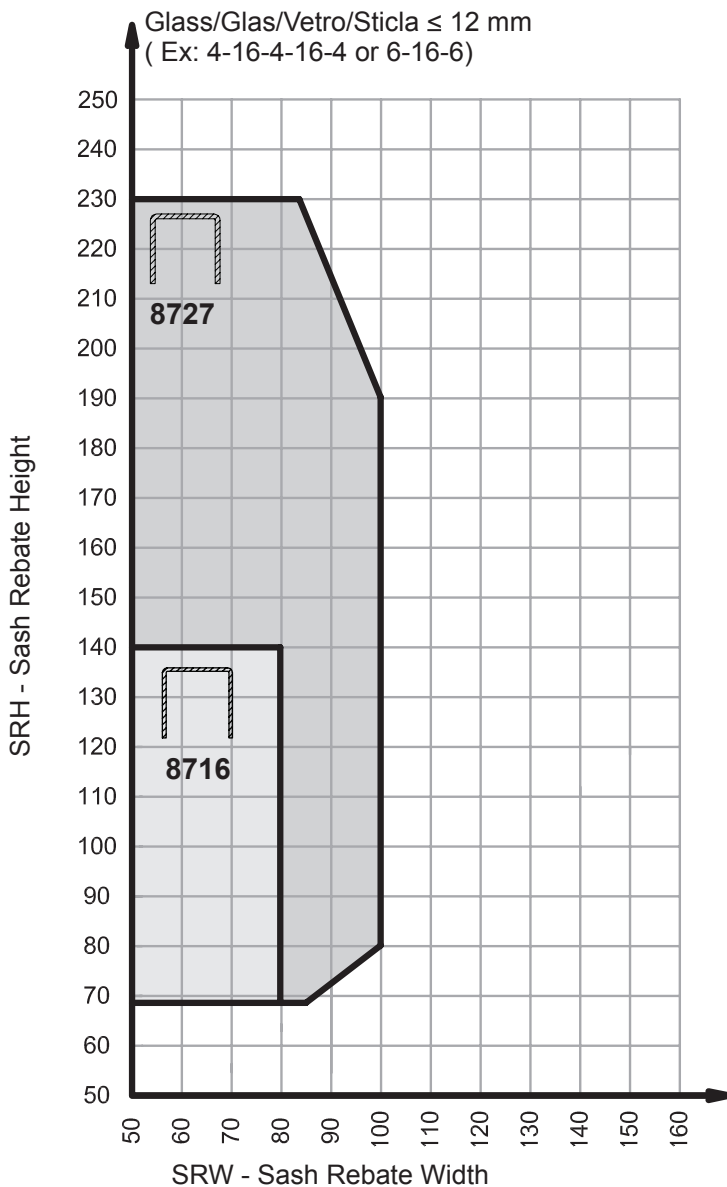
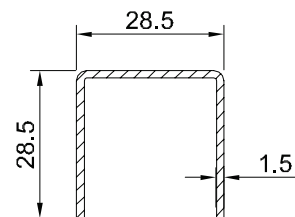

Sash 8088

The sash width must not be greater than the sash height by more than 25%

Die Flügelbreite darf die Flügelhöhe um nicht um mehr als 25% überschreiten.

La larghezza dell'anta non deve superare l'altezza della medesima di oltre il 25%

Lățimea cercevelei nu trebuie să depășească înălțimea acesteia cu mai mult de 25%

Window Sash Maximum Sizes / Fenster Flügelgrößen Diagramme /
Campi d'applicazione Anta Finestra / Dimensiuni maxime cercevea fereastră

Opening types

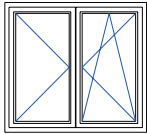

Profile: **WHITE / WEISS / BIANCO / ALB**

Glass: $\leq 30 \text{ kg/m}^2$

Sash: STV

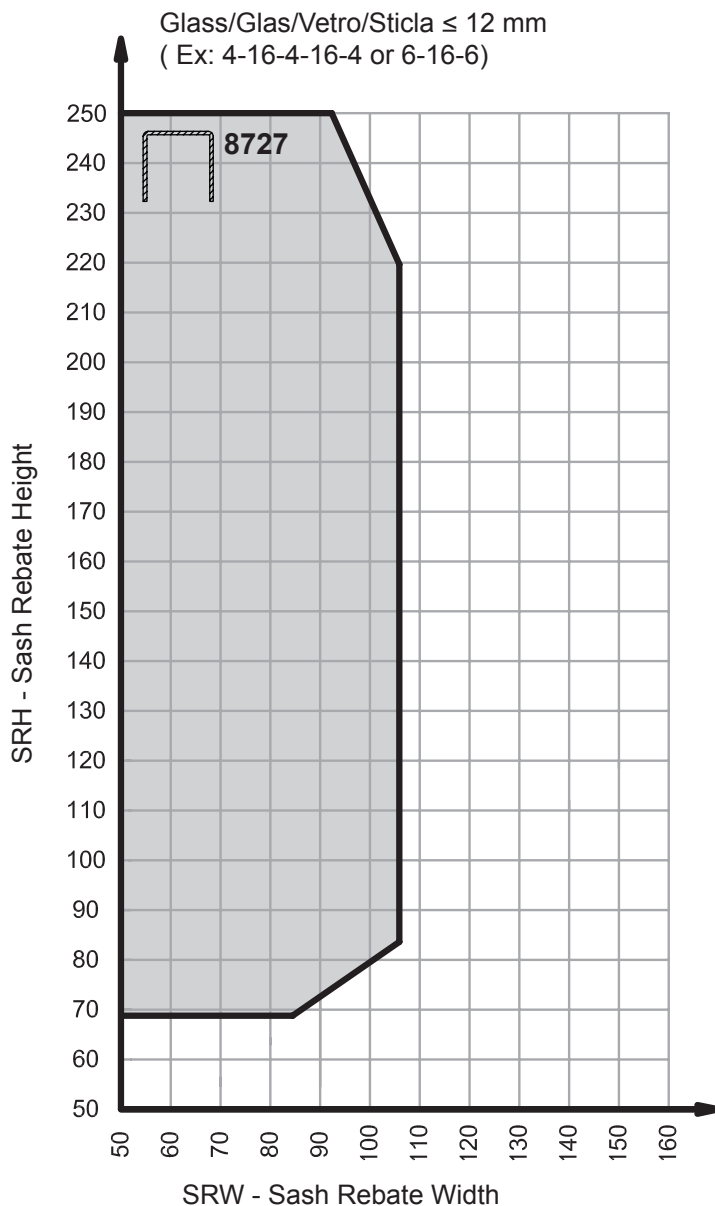

Steel

8727

28.5x28.5 $I_x=2,20 \text{ cm}^4$
t=2 mm

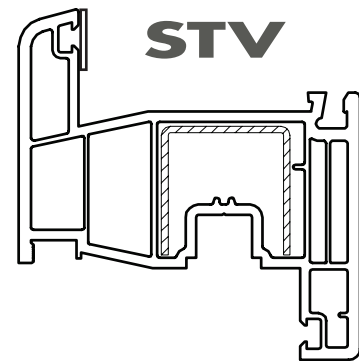
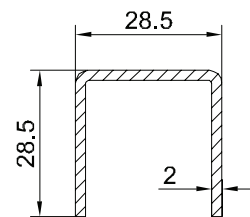

Sash 8088A

The sash width must not be greater than the sash height by more than 25%

Die Flügelbreite darf die Flügelhöhe um nicht um mehr als 25% überschreiten.

La larghezza dell'anta non deve superare l'altezza della medesima di oltre il 25%

Lățimea cercevelei nu trebuie să depășească înălțimea acesteia cu mai mult de 25%

Window Sash Maximum Sizes / Fenster Flügelgrößen Diagramme /
Campi d'applicazione Anta Finestra / Dimensiuni maxime cercevea fereastră

Opening types

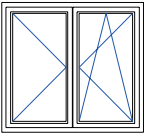

Profile: **COLOR / FARBE / PELLICOLATO / COLOR**

Glass: $\leq 30 \text{ kg/m}^2$

Sash: Standard

Steel

8727

28.5x28.5 $I_x=2,20 \text{ cm}^4$
t=2 mm

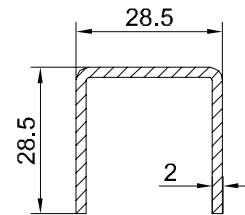

Steel

8716

28.5x28.5 $I_x=1,74 \text{ cm}^4$
t=1.5 mm

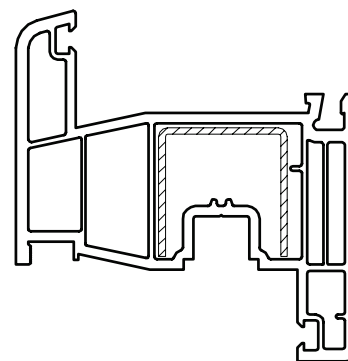
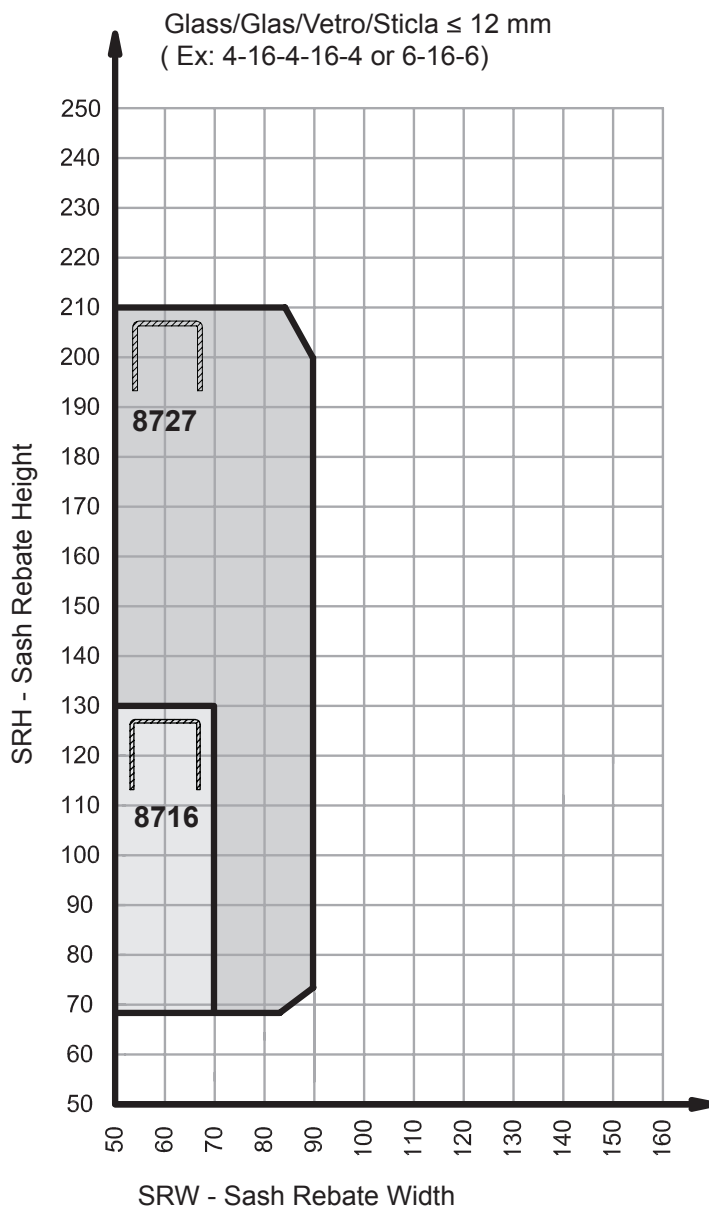
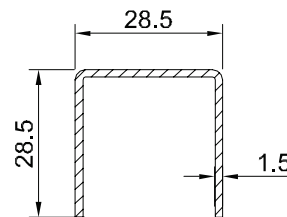

Sash 8088

The sash width must not be greater than the sash height by more than 25%

Die Flügelbreite darf die Flügelhöhe um nicht um mehr als 25% überschreiten.

La larghezza dell'anta non deve superare l'altezza della medesima di oltre il 25%

Lățimea cercevelei nu trebuie să depășească înălțimea acesteia cu mai mult de 25%

Window Sash Maximum Sizes / Fenster Flügelgrößen Diagramme /
Campi d'applicazione Anta Finestra / Dimensiuni maxime cercevea fereastră

Opening types

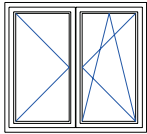

Profile: **COLOR / FARBE / PELLICOLATO / COLOR**

Glass: $\leq 30 \text{ kg/m}^2$

Sash: STV

Steel

8727

28.5x28.5 $I_x=2,20 \text{ cm}^4$

t=2 mm

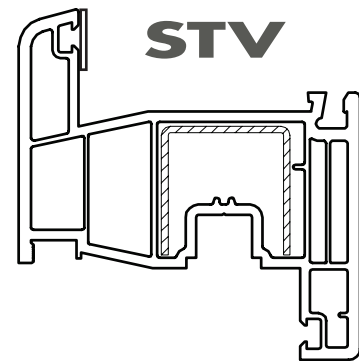
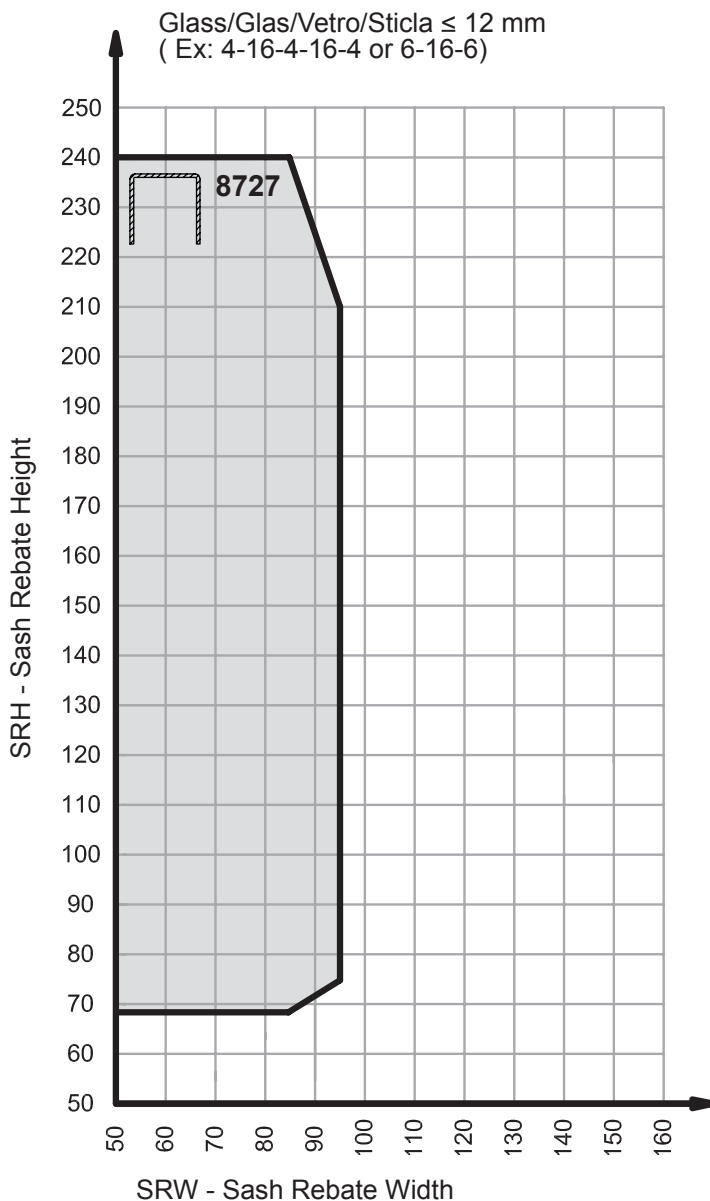
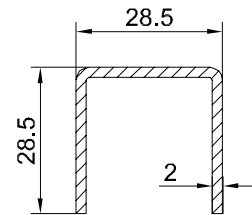

Sash 8088A

The sash width must not be greater than the sash height by more than 25%

Die Flügelbreite darf die Flügelhöhe um nicht um mehr als 25% überschreiten.

La larghezza dell'anta non deve superare l'altezza della medesima di oltre il 25%

Lățimea cercevelei nu trebuie să depășească înălțimea acesteia cu mai mult de 25%

Window Sash Maximum Sizes / Fenster Flügelgrößen Diagramme /
Campi d'applicazione Anta Finestra / Dimensiuni maxime cercevea fereastră

Opening types

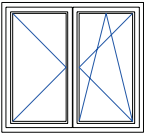

Profile: **WHITE and COLOR** / WEISS und FARBE /
BIANCO e PELLICOLATO / ALB si COLOR
Glass: $\leq 50 \text{ kg/m}^2$
Sash: Standard

Steel

8727
28.5x28.5 $I_x=2,20 \text{ cm}^4$
t=2 mm

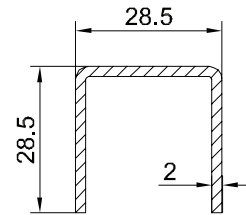

Steel

8716
28.5x28.5 $I_x=1,74 \text{ cm}^4$
t=1.5 mm

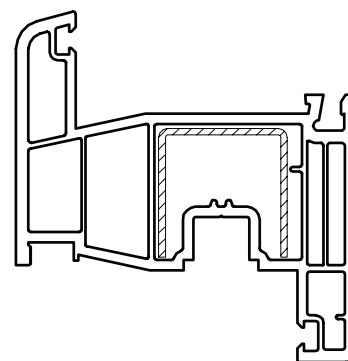
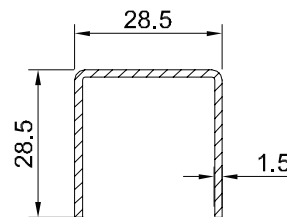

Sash 8088

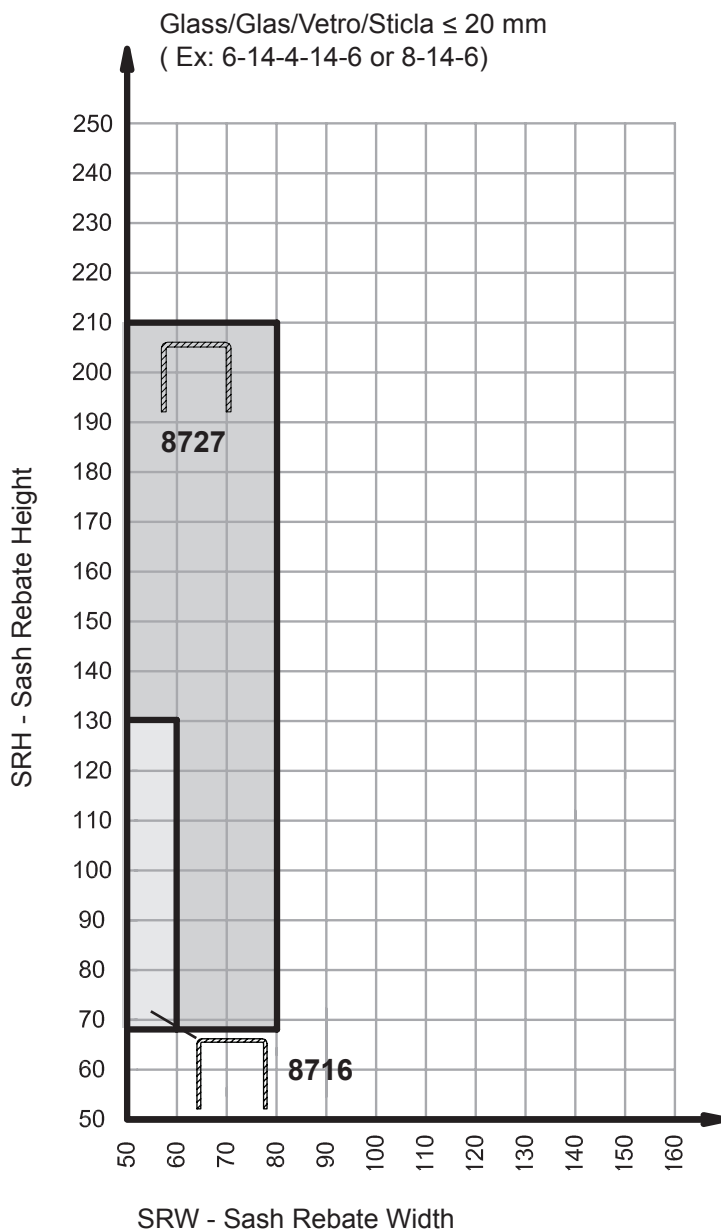

The sash width must not be greater than the sash height by more than 25%

Die Flügelbreite darf die Flügelhöhe um nicht um mehr als 25% überschreiten.

La larghezza dell'anta non deve superare l'altezza della medesima di oltre il 25%

Lățimea cercevelei nu trebuie să depășească înălțimea acesteia cu mai mult de 25%

Window Sash Maximum Sizes / Fenster Flügelgrößen Diagramme /
Campi d'applicazione Anta Finestra / Dimensiuni maxime cercevea fereastră

Opening types

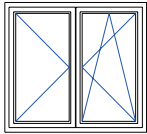

Profile: **WHITE** and **COLOR** / WEISS und FARBE /
BIANCO e PELLICOLATO / ALB si COLOR
Glass: $\leq 50 \text{ kg/m}^2$
Sash: STV

Steel

8727
28.5x28.5 $I_x=2,20 \text{ cm}^4$
t=2 mm

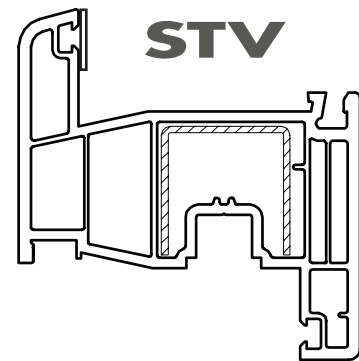
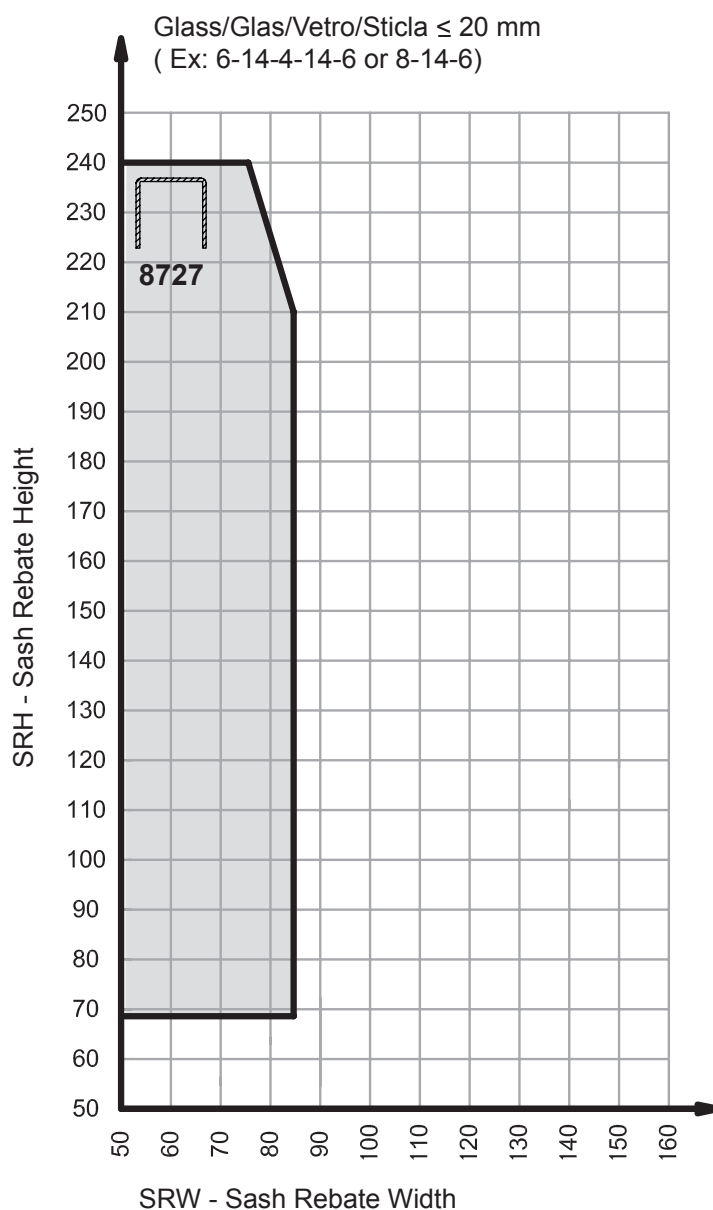
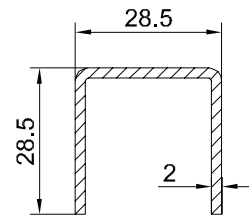

Sash 8088A

The sash width must not be greater than the sash height by more than 25%

Die Flügelbreite darf die Flügelhöhe um nicht um mehr als 25% überschreiten.

La larghezza dell'anta non deve superare l'altezza della medesima di oltre il 25%

Lățimea cercevelei nu trebuie să depășească înălțimea acesteia cu mai mult de 25%

Window Frame Maximum Sizes / Fenster Blendrahmengrößen Diagramme /
Campi d'applicazione Telaio Finestra / Dimensiuni maxime toc fereastră

Opening types

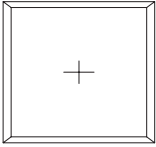



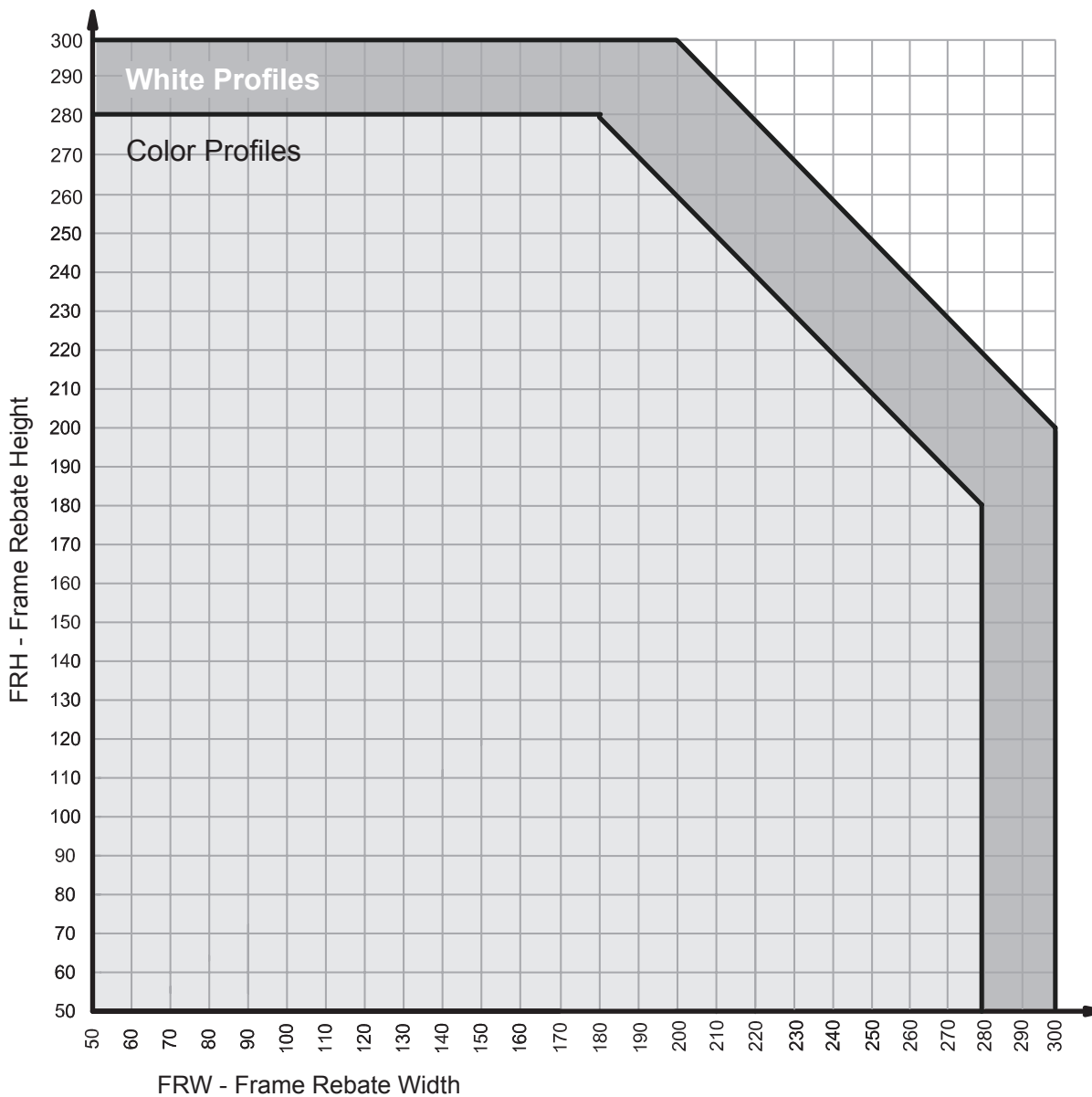

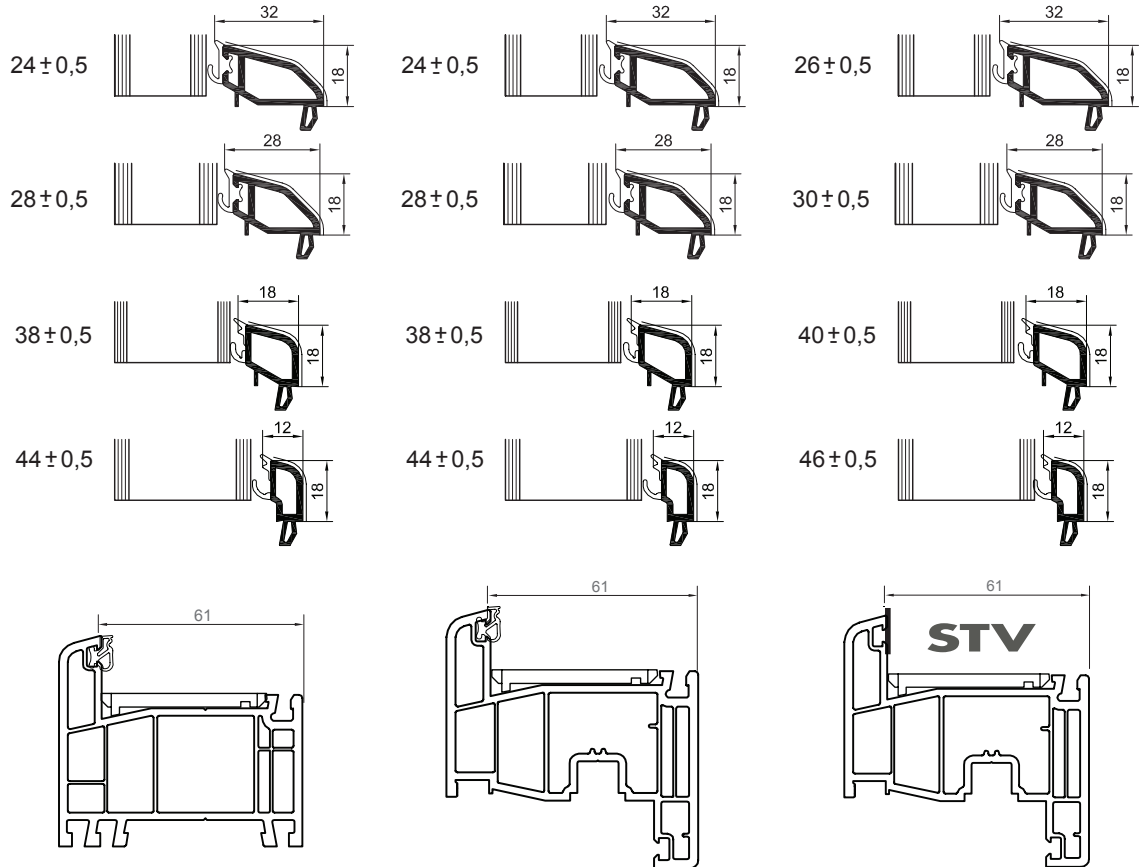

Profile: **WHITE** and **COLOR** / WEISS und FARBE /
BIANCO e PELLICOLATO / ALB si COLOR

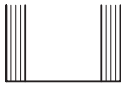
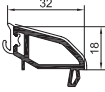

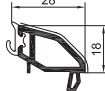
Glazing Beads / Glasleiste / Fermavetri / Baghete de fixare geam



Profile	Glass / Glas / Vetro / Sticlă	Glazing bead / Glasleiste Fermavetro / Baghetă	Gasket / Dichtung Guarnizione / Garnitură
Frame 8032, 8030, 8027 Sash 8088 Mullion 8080	 24 mm	7124 	black or gray
Frame 8032, 8030, 8027 Sash 8088 Mullion 8080	 28 mm	7128 	black or gray
Frame 8032, 8030, 8027 Sash 8088 Mullion 8080	 38 mm	7138 	black or gray
Frame 8032, 8030, 8027 Sash 8088 Mullion 8080	 44 mm	7144 	black or gray

