



# Aisle-Master

## COMBI-WR Walkie Reach



### Load Capacity Chart

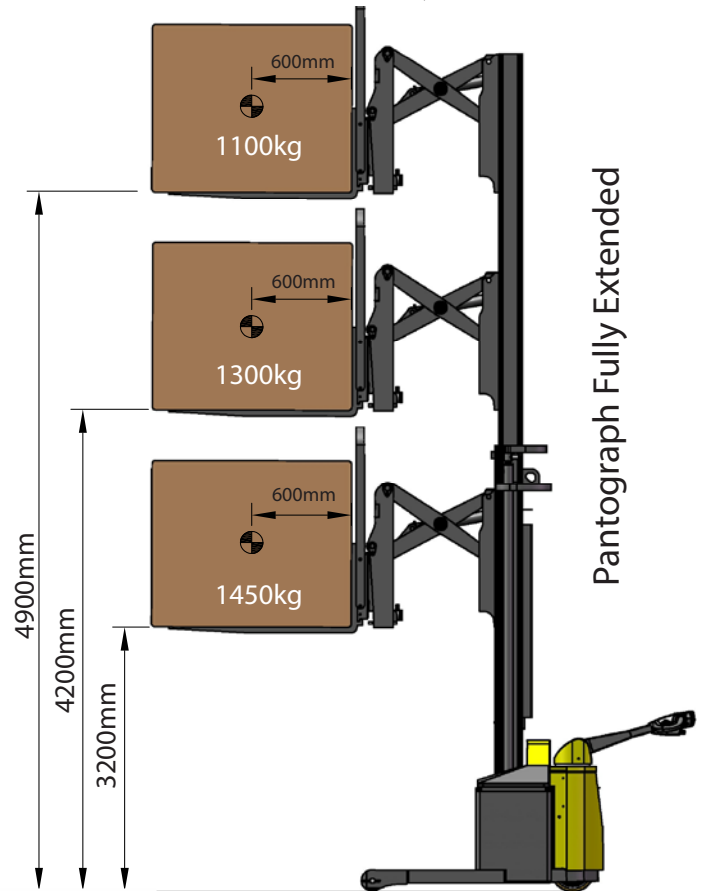

### Multi Position Tiller

International Application No. PCT/EP2012/067238

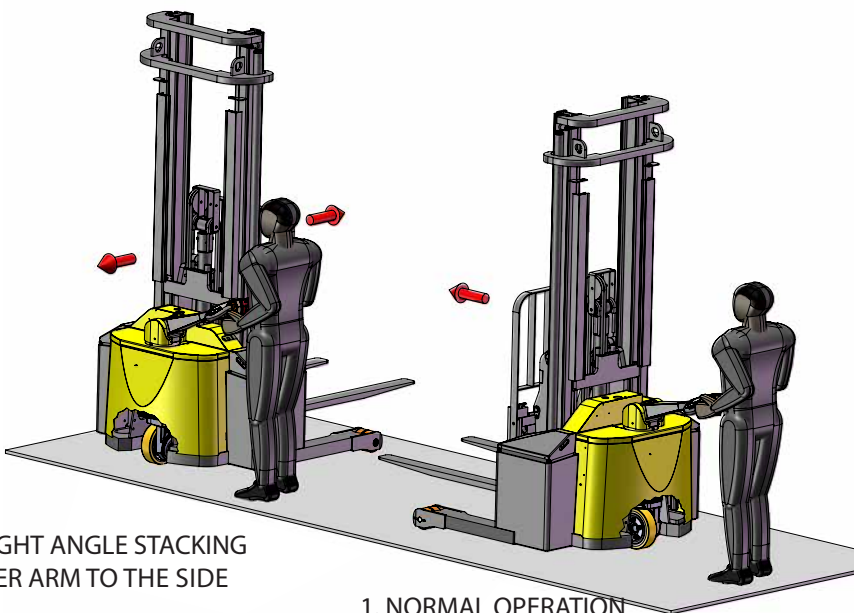

2. RIGHT ANGLE STACKING  
TILLER ARM TO THE SIDE

1. NORMAL OPERATION  
REAR WHEEL PARALLEL  
WITH TILLER ARM



Fork Lift Truck  
Association

**Winner**



Aisle-Master Ltd, Monaghan, Ireland  
Tel: +353 (0)47 80400

[www.Aisle-Master.com](http://www.Aisle-Master.com)



# Aisle-Master

## COMBI-WR Walkie Reach

	DESCRIPTION	STD	OPTIONAL	
1a	Max. Lift Height	3000mm	4200mm	4900mm
1b	Free Lift Height	900mm	1500mm	1850mm
2	Height Mast Closed	2100mm	2700mm	3050mm
3	Max. (Mast Raised)	4200mm	5400mm	6100mm
4	Overall Length	1950mm		
5	Fork Travel	590mm		
6	Ground Clearance Under Mast	80mm		
7	Ground Clearance to Centre of Wheelbase	50mm		
8	Width	1320mm		
9	Outside Spread of Fork Arms	815mm		
10	Track Front	1165mm		
11	Frame Opening	1008mm		
12	Load Centre Distance	600mm		
13	Overhang Front	603mm		
14	Wheelbase	1172mm		
15	Overhang Back	175mm		
16	Fork Side Shift	80mm Left / 80mm Right		
17	Length from Face of Fork	880mm		
18	Fork Backward Tilt	3°		
19	Fork Forward Tilt	3°		
20	Minimum Outside Radius	1350mm		
21	Leg Height	127mm		
22	Leg Length	530mm		
A	Capacity	1450kg @ 3200mm Lift		
B	Unladen Weight	2500kg / 2600kg / 2700kg		
C	Maximum Ground Speed	6 Km/h		
D	Gradability	5%		
E	Battery Capacity	24V / 270 Ah		
F	Fork Section	35mm x 100mm x 1070mm		
G	Front Tyre (Polyurethane)	OD 127mm / Width 75mm		
H	Rear Tyre (Vulkollan)	OD 250mm / Width 75mm		
I	Standard Colour	Yellow & Grey		
J	AC Electric Traction Motor	24V / 2.5 kW		
K	AC Electric Pump Motor	24V / 5 kW		

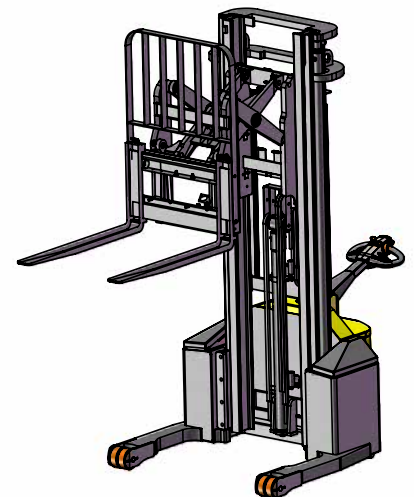
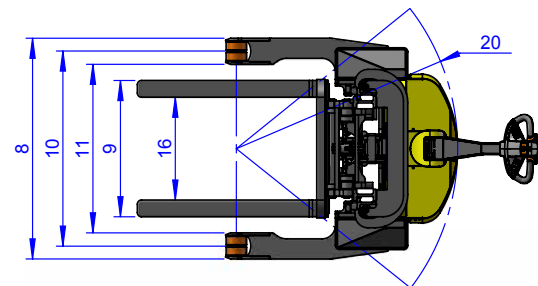
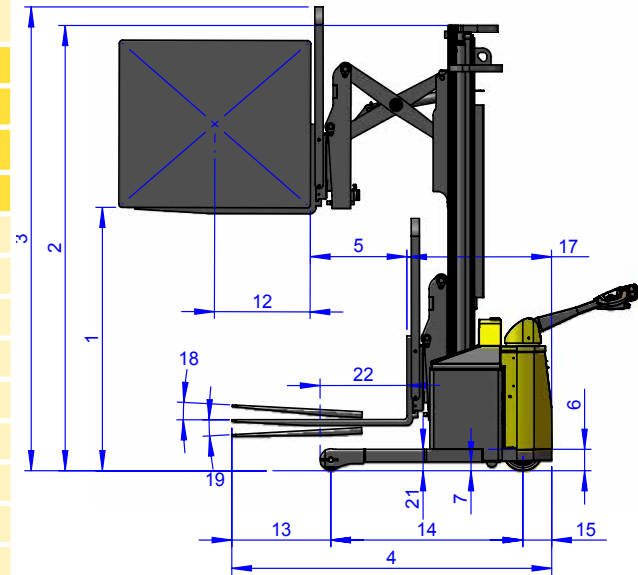

### Features Include:

- Pantograph
- Power Steering
- AC Motor Technology
- 1200mm High Load Back Rest
- Rear Wheel Drive
- 80/80mm Side Shift

Aisle-Master Ltd.  
Co. Monaghan  
Ireland

Tel: +353 47 80400 | Fax: +353 47 80402  
Australia: 1300 369 899  
E-Mail: info@aisle-master.com  
Website: www.aisle-master.com



Aisle-Master Ltd, Monaghan, Ireland  
Tel: +353 (0)47 80400

[www.Aisle-Master.com](http://www.Aisle-Master.com)