

BIMBA meets your NEEDS.

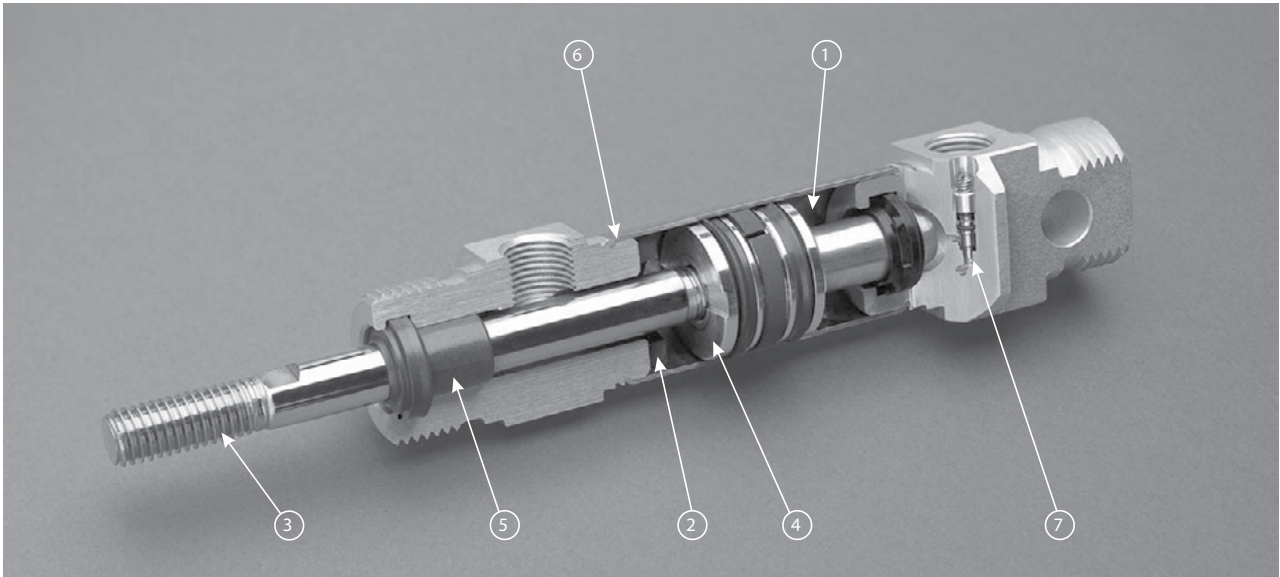

Reliable Service, World-Wide

- From a world-wide leader producing millions of actuators each year.

Environmental

- Pre-lubricated for longer, maintenance free operation. ①

Noise Reduction

- Shock absorbing bumpers. ②

Performance and Quality Processes Throughout

- Roll formed threads. ③
- High strength pistons permanently rivetted and sealed. ④
- Roller burnished stainless steel rods.

Productivity

- Advanced bearing and seal materials for higher speed applications. ⑤

Safety

- Double rolled construction. ⑥
- Permanent mechanical retention; needles cannot blowout under pressure. ⑦

Reduced Envelope

- Space savings available resulting from smaller external dimensions.

A Material For Any Application

- Heads available in Aluminium, Stainless Steel and Delrin.

Unique Customer Solutions

- Rapid design and delivery time for custom modifications.

The model number for all Bimba ISO6432 cylinders consists of five Alpha-Numeric clusters. The first designates the TYPE, the second the BORE SIZE, the third the STROKE LENGTH, the fourth the MOUNTING STYLE, and the fifth the OPTIONS.

Please refer to the chart below for an explanation of the following model number:

EM-25-100-N-CNT : This is an ISO6432 type cylinder with a magnet, with 25mm bore size, 100mm stroke size, nose mounted, and with cushions in both heads and no thread rod.

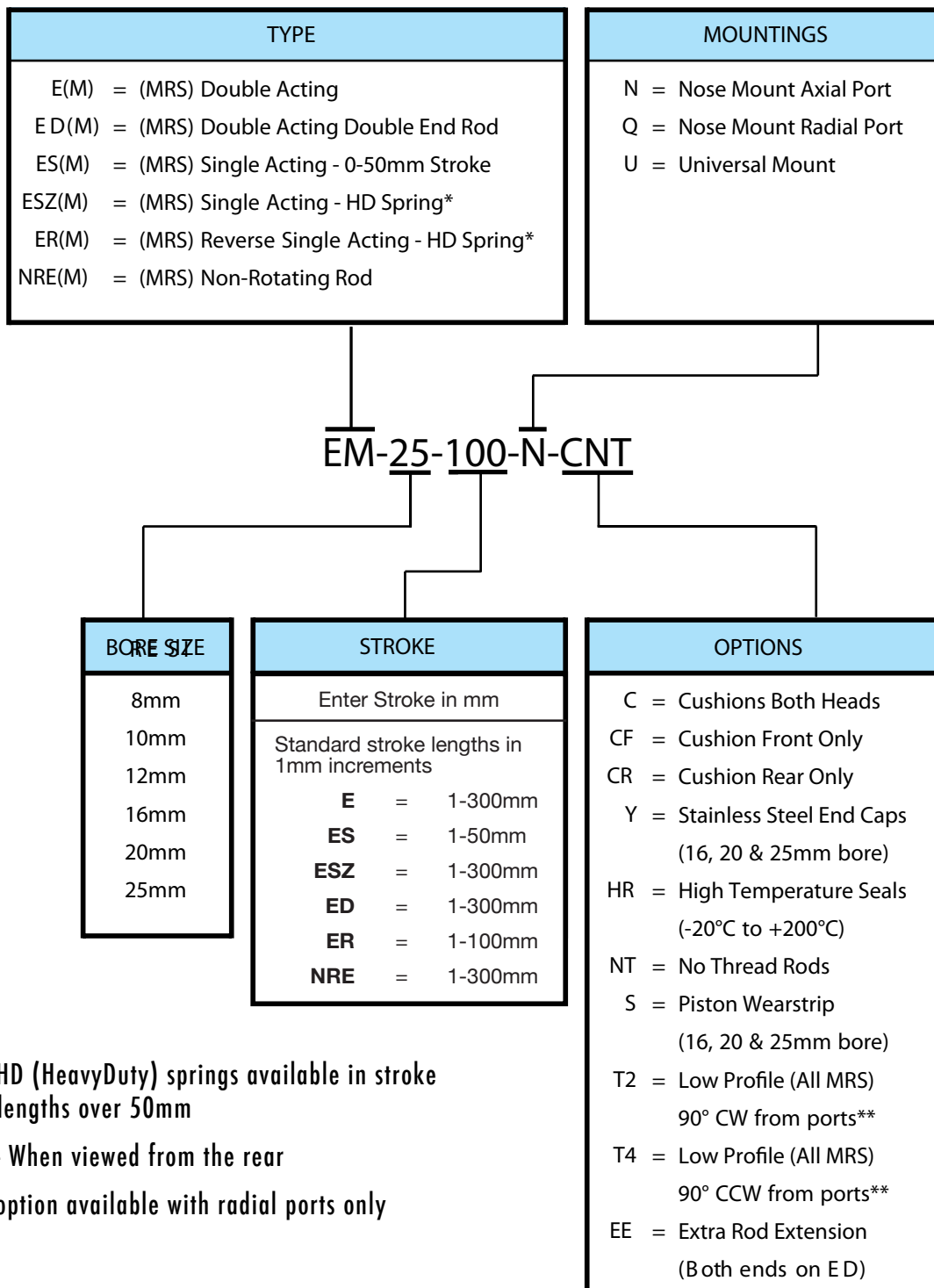

* - HD (HeavyDuty) springs available in stroke lengths over 50mm

** - When viewed from the rear

Y - option available with radial ports only

COMPATIBILITY CHART

Due to design or incompatibility restrictions, the following options may NOT be ordered in combination. For example stainless steel end cap may not be ordered with cushions. Options NT and EE are available independently, with each other or with all viable option combinations.

BORE	OPTION				
	NRE	C	Y	M	S
8	N/A	N/A	N/A	N/A	N/A
10	N/A	N/A	N/A	N/A	N/A
12	N/A	N/A	N/A	N/A	N/A
16	C, Y	NRE, Y	NRE, C	S	M
20	C, Y	NRE, Y	NRE, C	S	M
25	C, Y	NRE, Y	NRE, C	S	M

CONVERSION TABLE

	Metric Unit Of Measure	Metric To Imperial Conversion	Imperial Unit Of Measure	Imperial To Metric Conversion
Force	Newtons (N)	x 0.2248	Pounds (Lbs)	x 4.448
Pressure	Bar (b)	x 14.5	Pounds Per Square Inch (PSI)	x 0.069
Measurement	Millimetres	x 0.03937	Inches	x 25.4
Temperature	Centigrade	$\frac{9 \times ^\circ\text{C}}{5} + 32$	Fahrenheit	$\frac{5 \times (^\circ\text{F} - 32)}{9}$

GENERAL SPECIFICATIONS

	BORE					
	8	10	12	16	20	25
Cushion Length (mm) Each End	N/A			18	21	21
Operating Pressure Range Maximum Minimum - Double Acting	10 bar 0.5 bar					
Operating Temperature Range Standard Seals High Temperature Seals	-10°C to +80°C -20°C to +200°C					
Operating Media	Filtered Compressed Air/Lubricated or Non-Lubricated					
Standard Stroke Lengths	See Table on page 2.2					
Maximum Stroke Length*	1000mm					
Stroke Tolerance	+1.0mm/-0mm					
Piston Speed	5mm/s to 1000mm/s (Higher speed available on request)					
Life Expectancy	3000km					

* Varies according to bore size, please consult Mac Valves Pacific.

WEIGHT

	BORE					
	8	10	12	16	20	25
Option N	20	22	41	53	102	149
Option U	23	25	46	59	118	167
Type ED	28	30	61	74	152	218
adder per 10mm stroke	2	2	4	5	8	11

Weights (approximate) are for zero stroke, in grams.

ROD BUCKLING FORMULA

The maximum recommended cylinder stroke is dependent upon:

1. Mounting type
2. Rod diameter
3. Rod end connection

Using the following formula it is possible to determine the buckling load for a given stroke length of cylinder.

HOW TO CALCULATE ROD BUCKLING FORCES EXAMPLE:

Q. What is the buckling load for a 25mm bore cylinder with a pivoted and guided load attached, stroke 200mm?

A. Using the formula: $BL = \frac{\pi^2 EJ}{(l \times M)^2 S}$

$$BL = \frac{\pi^2 EJ}{(l \times M)^2 S}$$

- BL = Permissible Buckling Load (N)
- E = Young's Modulus of Elasticity (N/mm²)
- J = Moment of Inertia (mm⁴)
- l = Buckling Length = Stroke (mm)
- M = Stroke Multiplier (see table below)
- S = Safety Factor (recommended minimum 5)

$$\begin{aligned}
 E &= 190.05 \times 10^3 \text{ N/mm}^2 \\
 l &= 200 \text{ mm (stroke)} \\
 M &= 2 \text{ (for pivoted and guided load)} \\
 S &= 5 \text{ (safety factor)} \\
 D &= 10 \text{ mm (piston rod diameter for cylinder)} \\
 J &= \frac{\pi D^4}{64} = \frac{\pi 10^4}{64} = 490.87 \text{ mm}^4 \\
 BL &= \frac{\pi^2 \times 190.05 \times 10^3 \times 490.9}{(2 \times 200)^2 \times 5} = 1150.9 \text{ N} = 1.15 \text{ kN}
 \end{aligned}$$

ROD END CONNECTION	CYLINDER MOUNTING	TYPE	STROKE MULTIPLIER
FIXED & GUIDED		A	0.5
PIVOTED & GUIDED		B	0.7
FIXED & SUPPORTED		C	2
PIVOTED & GUIDED		C	2

OUTPUT FORCES

Cylinder output forces can be determined in one of two ways:

1. Calculation

$$\text{Cylinder Output Force (N)} = \text{Power Factor} \times \text{Pressure (bar)}$$

BORE	POWER FACTOR	
	EXTENSION	RETRACTION
8	5.3	4.0
10	7.9	6.6
12	11.3	8.5
16	20.1	17.3
20	31.4	26.1
25	49.1	41.2

2. Graph

Extend

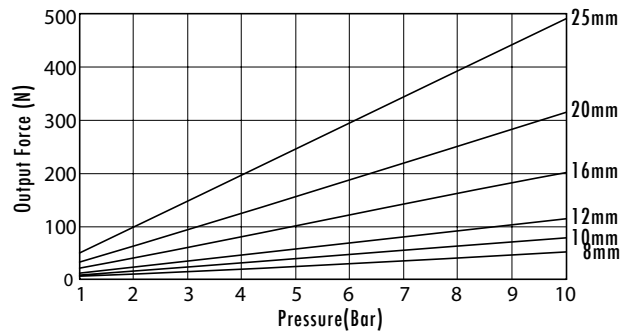

Retract

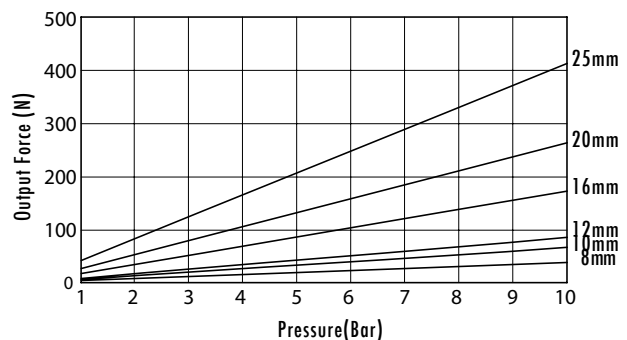

AIR CONSUMPTION CHART

The air consumption chart is based on the following formula for a complete cylinder cycle (cylinder extends and retracts):

$$Q = \left[\frac{\pi D^2}{4} + \left(\frac{\pi(D^2 - d^2)}{4} \right) \right] h p 10^{-6}$$

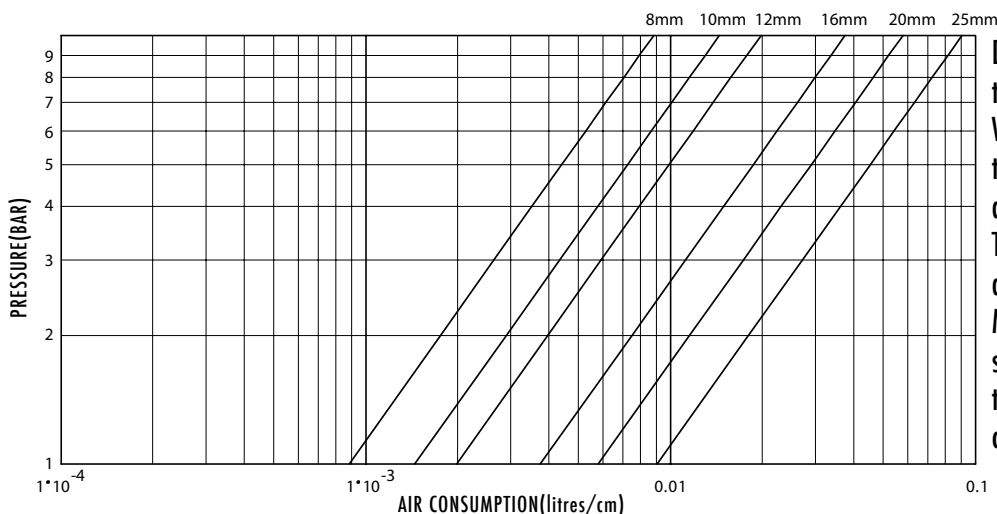

Draw a line across for the pressure used. Where this intersects the required bore size, draw vertical line down. This will give you the air consumption. Multiply this by the stroke in cm, and this will give the air consumption per cycle.

EXAMPLE:

Q = Air volume per cm of stroke(L)
D = Piston or piston rod diameter(mm)
h = Stroke(mm)
p = Operating pressure(bar)
d = Piston rod diameter(mm)

Cylinder Stroke = 2.5cm
 Cylinder Bore = ø 25mm
 Operating Pressure = 7Bar
 Air Consumption = 0.158 Litres

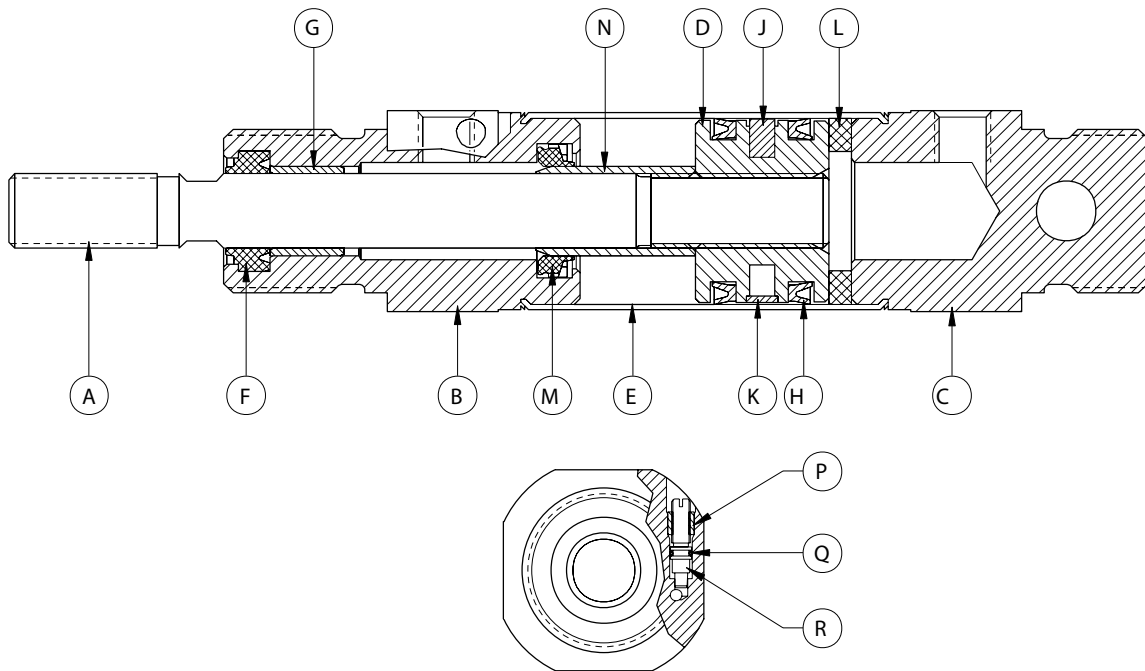

ITEM	COMPONENT	MATERIAL
A	Piston Rod	Stainless Steel (type 303 s31)
B	Rod Guide	Aluminium Alloy (anodised) Delrin® Plastic - (type PCE) Stainless Steel - (option Y)
C	Rear Head	Aluminium Alloy (anodised) Delrin® Plastic - (type PCE) Stainless Steel - (option Y)
D	Piston	Aluminium Alloy Brass - (type ED)
E	Body	Stainless Steel (type 304)
F	Rod Seal/Rod Wiper	Nitrile (NBR) or Fluoro-rubber (FPM) - (option HR)
G	Rod Bearing	Self Lubricating Thermoplastic Alloy
H	Piston Seal	Nitrile (NBR) or Fluoro-rubber (FPM) - (option HR)
J	Magnet	Neodymium Iron Boron Nitrile
K	Piston Bearing Ring	Carbon Filled PTFE
L	Bumper	Fluoro-rubber (FPM)
M	Cushion Seal	Nitrile (NBR) - Standard or Fluoro-rubber (FPM) - (option HR)
N	Cushion Sleeve	Aluminium Alloy
P	Cushion Screw Retainer	Aluminium Alloy (anodised) Stainless Steel - (type PCE)
Q	Cushion o-ring	Fluoro-rubber (FPM)
R	Cushion Screw	Stainless Steel (type 303 s31)

NOSEMOUNT - N Option

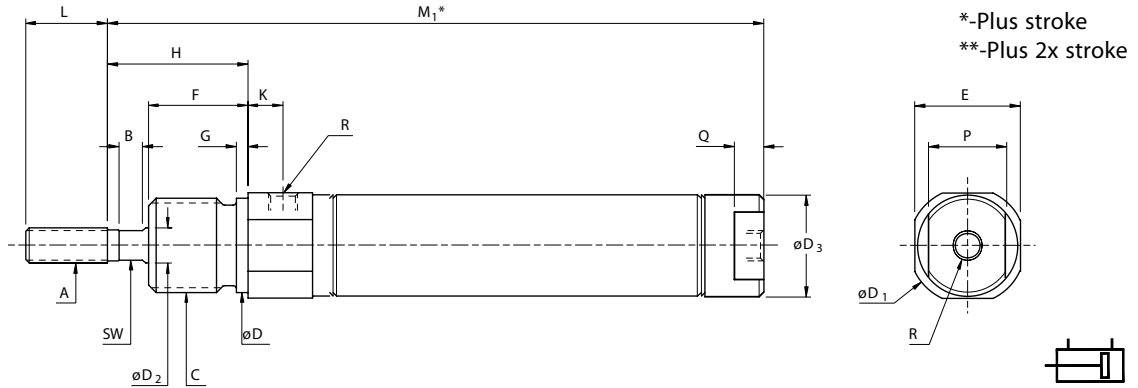

UNIVERSAL MOUNT - U Option

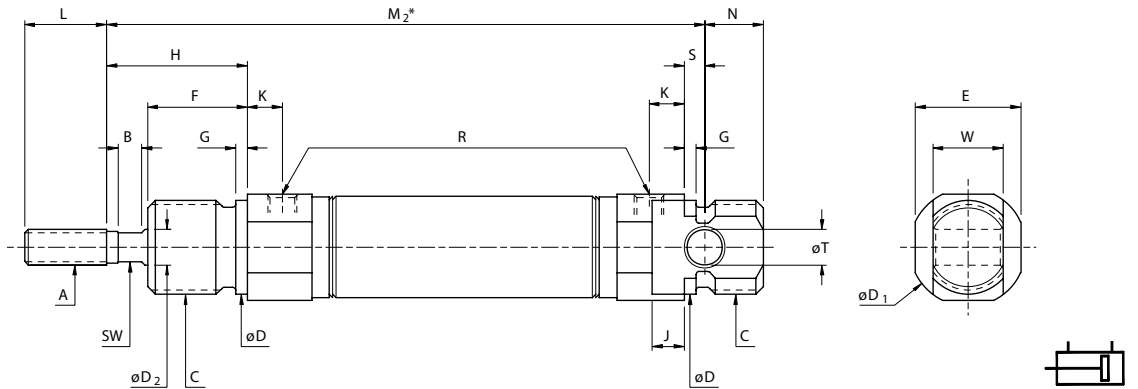

DOUBLE ENDED

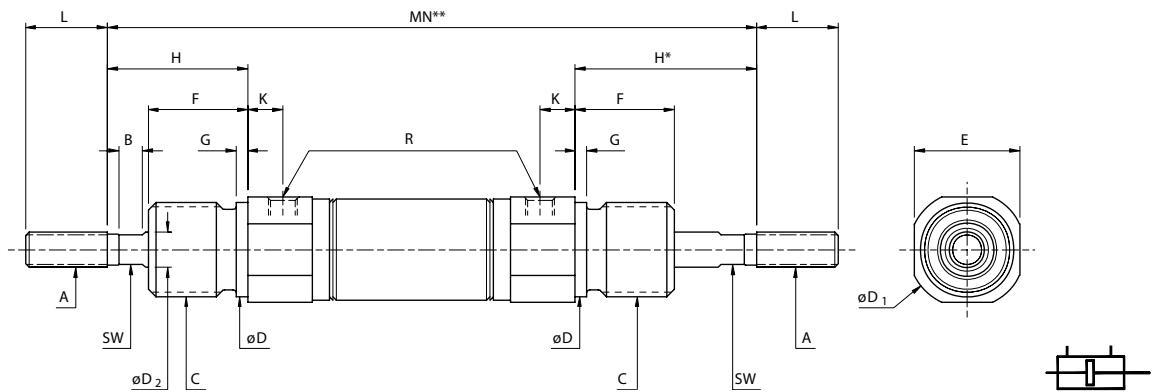

Bore	A ^{6g}	B	C ^{6g}	D	D ₁	D ₂ ^{h8}	D ₃	E	F	G	H	J	K	L	P	Q	N	R	S	T ^{H9}	W ^{d13}	SW	M ₁	M ₂	MN
8	M4x0.7	-	M12x1.25	12	17	4	9	15	12	2	16	3	6	12	8	4	9	M5x0.8	3	4	8	-	56.5	64	77
10	M4x0.7	-	M12x1.25	12	17	4	11	15	12	2	16	3	6	12	10	5	9	M5x0.8	3	4	8	-	58	64	77
12	M6x1.0	4	M16x1.5	16	20	6	13	18	17	2	24	5.4	6	14	10	5	8	M5x0.8	3.6	6	12	5	68.7	77	97
16	M6x1.0	4	M16x1.5	16	20	6	17	18	17	2	24	5.5	6	14	13	5	10	M5x0.8	3.5	6	12	5	74	84	104
20	M8x1.25	4	M22x1.5	22	28	8	21	24	19	3	25	8	8	19	19	7	11	G1/8	4	8	16	6	84.5	96	117
25	M10x1.25	4	M22x1.5	22	30	10	26	27	22	3	30	6	8	20	22	8	11	G1/8	6	8	16	8	92	106	130

ISO 6432 - Double Acting - with Adjustable Cushioning



Q option

Radially ported rear head available on non-cushioned cylinders. The M_1 dimension increases by the amount shown a long side.

Bore	Adder	Bore	Adder
8	4.5	16	6.5
10	3	20	7.5
12	4.7	25	8

NOSEMOUNT-N Option

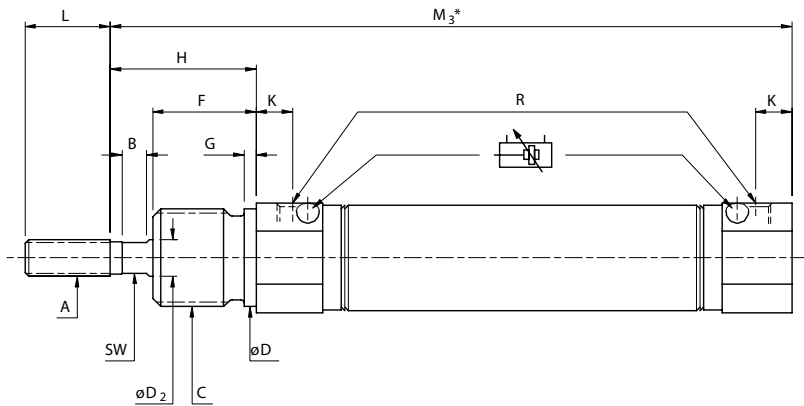

* - Plus stroke

** - Plus 2x stroke

UNIVERSAL MOUNT-U Option

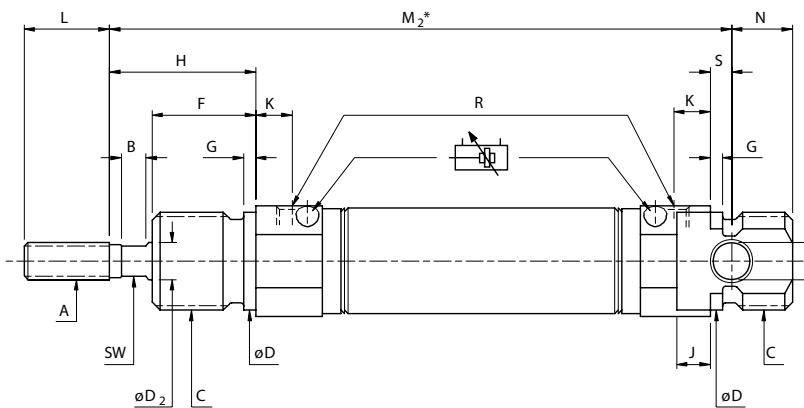

DOUBLE ENDED

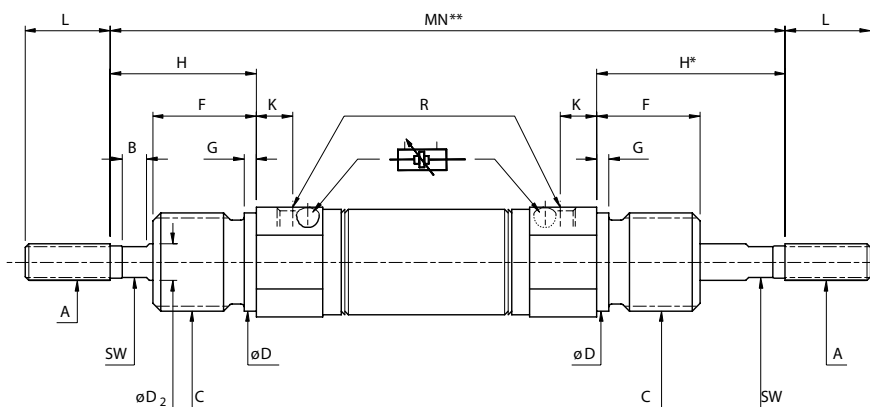

Bore	A ^{6g}	B	C ^{6g}	D	D ₁	D ₂ ^{h8}	E	F	G	H	J	K	L	N	R	S	T ^{H9}	W ^{d13}	SW	M ₂	M ₃	MN
16	M6x1.0	4	M16x1.5	16	20	6	18	17	2	24	5.5	6	14	10	M5x0.8	3.5	6	12	5	84	80.5	104
20	M8x1.25	4	M22x1.5	22	28	8	24	19	3	25	8	8	19	11	G1/8	4	8	16	6	96	92	117
25	M10x1.25	4	M22x1.5	22	30	10	27	22	3	30	6	8	20	11	G1/8	6	8	16	8	106	100	130

The ESZ & ER series offer a heavier spring force than the ES, and the flexibility of strokes exceeding 50mm.

NOSEMOUNT-N Option

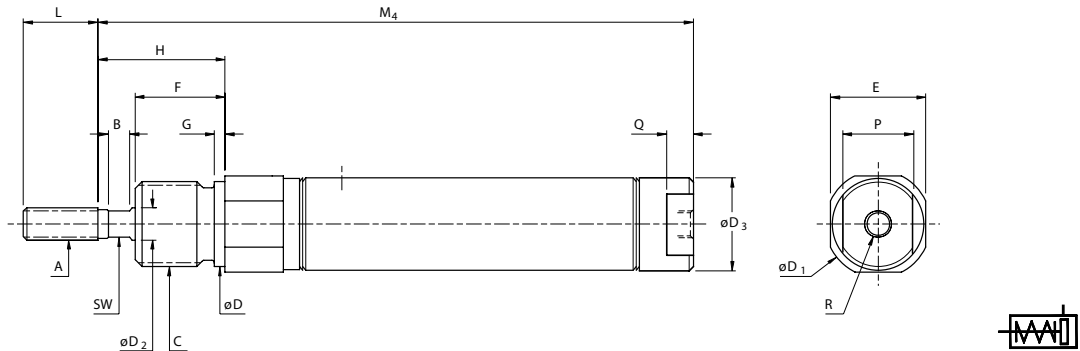

UNIVERSAL MOUNT-U Option

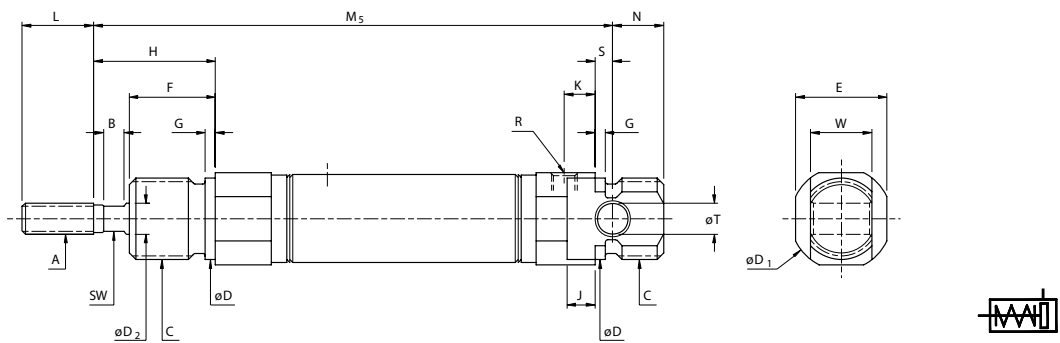

NOSEMOUNT-N Option

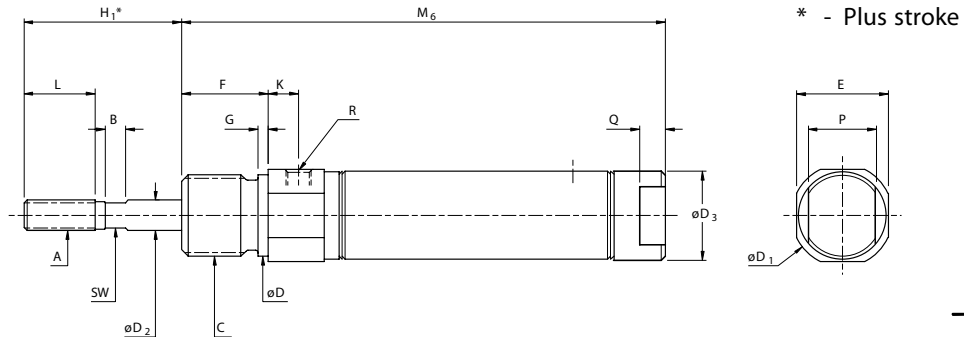

UNIVERSAL MOUNT-U Option

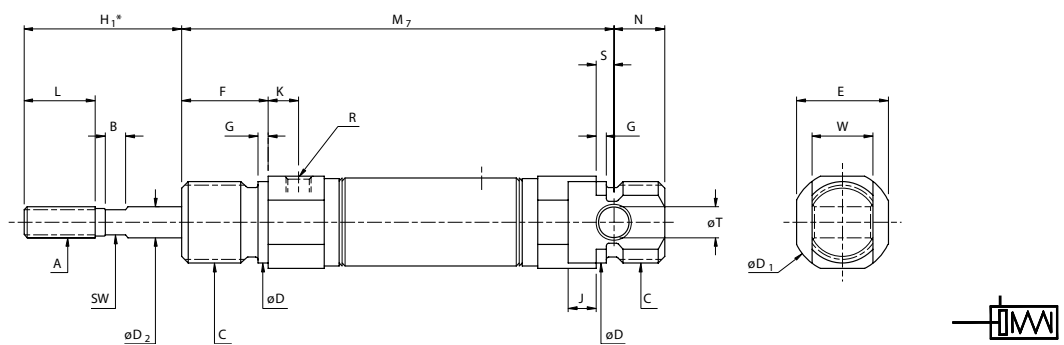

See following table for dimensions

Bore	A ^{6g}	B	C ^{6g}	D	D ₁	D ₂ ^{h8}	D ₃	E	F	G	H	H ₁	J	K	L	N	P	Q	R	S	T ^{H9}	W ^{d13}	SW
8	M4x0.7	-	M12x1.25	12	17	4	9	15	12	2	16	16	3	6	12	9	8	4	M5x0.8	3	4	8	-
10	M4x0.7	-	M12x1.25	12	17	4	11	15	12	2	16	16	3	6	12	9	10	5	M5x0.8	3	4	8	-
12	M6x1.0	4	M16x1.5	16	20	6	13	18	17	2	24	21	5.4	6	14	8	10	5	M5x0.8	3.6	6	12	5
16	M6x1.0	4	M16x1.5	16	20	6	17	18	17	2	24	21	5.5	6	14	10	13	5	M5x0.8	3.5	6	12	5
20	M8x1.25	4	M22x1.5	22	28	8	21	24	19	3	25	27	8	8	19	11	19	7	G1/8	4	8	16	6
25	M10x1.25	4	M22x1.5	22	30	10	26	27	22	3	30	28	6	8	20	11	22	8	G1/8	6	8	16	8

CALCULATING CYLINDER LENGTHS

In order to provide greater customer flexibility, Bimba ESZ and ER cylinders can be fitted with multiple springs.

To calculate the length ("M" dimension), use the following formula based on the table below:

Example 1 : ESZ-25-78-U

ESZ-25-_-U Base length (M_5) = 103mm
 Multiplier = Stroke \div Increment = $78 \div 25 = 3.12$
 Multiplier = 3 (always round down)
 Multiplier x Adder = $3 \times 47 = 141$ mm
 Add Base Length = $141 + 103 = 244$

Add whole stroke increment:

Stroke - (Multiplier x 25) = $78 - 75 = 3$
 ESZ-25-78-U = $244 + 3 = 247$

Example 2 : ER-12-86-N

ER-12-86-N Base length (M_6) = 60.2mm
 Multiplier = Stroke \div Increment = $86 \div 12.5 = 6.88$
 Multiplier = 6 (always round up)
 Multiplier x Adder = $6 \times 29 = 174$ mm
 Add Base Length = $174 + 60.2 = 234.2$

Add whole stroke increment:

Stroke - (Multiplier x 12.5) = $86 - 75 = 11$

ER-12-86-N = $234.2 + 11 = 245.2$

	ESZ - Single Acting, Rod To Retract				ER - Single Acting, Rod To Extend			
	$M_4(N)$	$M_5(U)$	Adder	Increment	$M_6(N)$	$M_7(U)$	Adder	Increment
8	63.8	71.3	20.8	12.5	51.5	59	20.8	12.5
10	57	63	24		53	59	29	
12	67.2	75.5	26.5		60.2	68.5	29	
16	72	82	48.5	25	65	75	49	25
20	81.5	93	46.5		75.5	87	49	
25	89	103	47		81	95	41.7	

SPRING FORCES

Bore	ES (available up to 50mm stroke)				ESZ & ER	
	Preload At Strokes (N)			Final Load (N)	Preload At 10mm Stroke (N)	Final Load (N)
	10mm	25mm	50mm			
8	5.1	4.2	2.6	5.7	1.8	8
10	5.1	4.2	2.6	5.7	3.1	8
12	5.8	4.4	3.1	6.2	4.9	16
16	5.8	4.4	3.1	6.2	8.9	22.7
20	20	16.5	11.1	22	12	31.7
25	28	23.1	15.6	31.1	12	39.2

CLEVIS FOOT

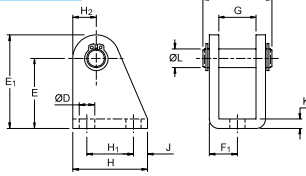

Bore	Type	D	E	E ₁	F	F ₁	G	H	H ₁	H ₂	J	K	L
8, 10	CFB-1	4.5	24	29	17	6.5	8.1	20	12.5	5	4	2.5	4
12, 16	CFB-2	5.5	27	34	23	9	12.1	25	15	7	5	3	6
20, 25	CFB-3	6.6	30	40	29.5	12	16.1	32	20	10	6	4	8

FOOT MOUNTING

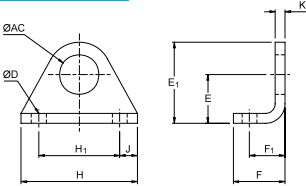

Bore	Type	AC	D	E	E ₁	F	F ₁	H	H ₁	J	K
8, 10	FB-1	12.1	4.6	15	25	16	11	36	25	5.5	3
12, 16	FB-2	16.1	5.6	20	33	20	14	45	32	6.5	4
20, 25	FB-3	22.1	6.6	25	40	24	17	56	40	8	4.5

ROD CLEVIS

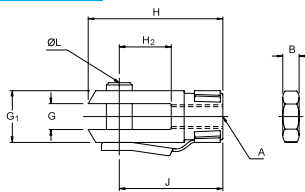

Bore	Type	A	B	G	G ₁	H	H ₂	J	L
8, 10	RC-M4x0.7	M4x0.7	3.2	4	8	21	8	16	84
12, 16	RC-M6x1.0	M6x1.0	5	6	12	31	12	24	6
20	RC-M8x1.25	M8x1.25	4	8	16	42	16	32	8
25	RC-M10x1.25	M10x1.25	5	10	20	52	24	40	10

FLANGE MOUNTING

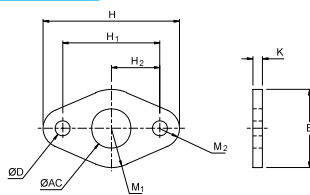

Bore	Type	AC	D	E	H	H ₁	H ₂	K	M ₁	M ₂
8, 10	MF-1	12.1	4.6	24	42	30	15	3	12	6
12, 16	MF-2	16.1	5.6	28	54	40	20	4	14	7
20, 25	MF-3	22.1	6.6	38	66	50	25	4.5	19	8

SPHERICAL ROD EYE

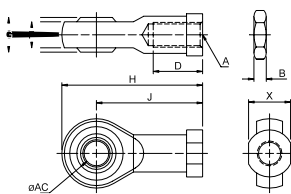

Bore	Type	A	AC	B	D	F	G	H	J	X
8, 10	SRE-M4x0.7	M4x0.7	5	3.2	10	6	8	36	27	9
12, 16	SRE-M6x1.0	M6x1.0	6	5	12	6.75	9	40	30	11
20	SRE-M8x1.25	M8x1.25	8	4	16	9	12	48	36	14
25	SRE-M10x1.25	M10x1.25	10	5	20	10.5	14	57	43	17

ROD/MOUNTING NUT

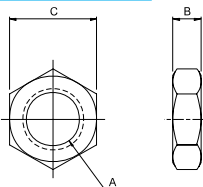

Bore	Type	A	B	C	Type	A	B	C
8, 10	RN-1	M4x0.7	3.2	7	MN-3	M22x1.5	10	32
12, 16	RN-2	M6x1.0	5	10				
20	RN-3	M8x1.25	4	13				
25	RN-4	M10x1.25	5	17				
					MN-1	M12x1.25	7	19
					MN-2	M16x1.5	8	24

ROD COUPLER

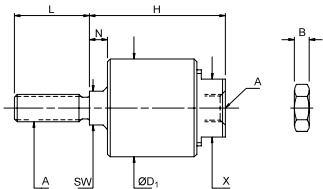

Bore	Type	A	B	D ₁	H	L	N	SW	X
8, 10	AC-M4x0.7	M4x0.7	3.2	14	24	14	6.5	-	11.3
12, 16	AC-M6x1.0	M6x1.0	5	17	24	16	5	5	10
20	AC-M8x1.25	M8x1.25	4	29	40	22	5.3	10	17
25, 32	AC-M10x1.25	M10x1.25	5	29	40	24	5.3	10	17
40	AC-M12x1.25	M12x1.25	7	32	47	24	8.2	13	20
50, 63	AC-M16x1.5	M16x1.5	8	32	48	32	10	13.5	20
80, 100	AC-M20x1.5	M20x1.5	9	45	57	40	10	21	28

BIMBA meets your NEEDS.

The model number for all Bimba PCE cylinders consists of five alpha-numeric clusters. The first designates the TYPE, the second the BORE SIZE, the third the STROKE LENGTH, the fourth the MOUNTING style, and the fifth the OPTIONS.

Please refer to the charts below for an explanation of the following model number:

PCEM-25-100-N-CNT: This is a PCE type cylinder with a magnet, with 25mm bore size, 100mm stroke size, nose mounted, and with cushions in both heads and no rod threads.

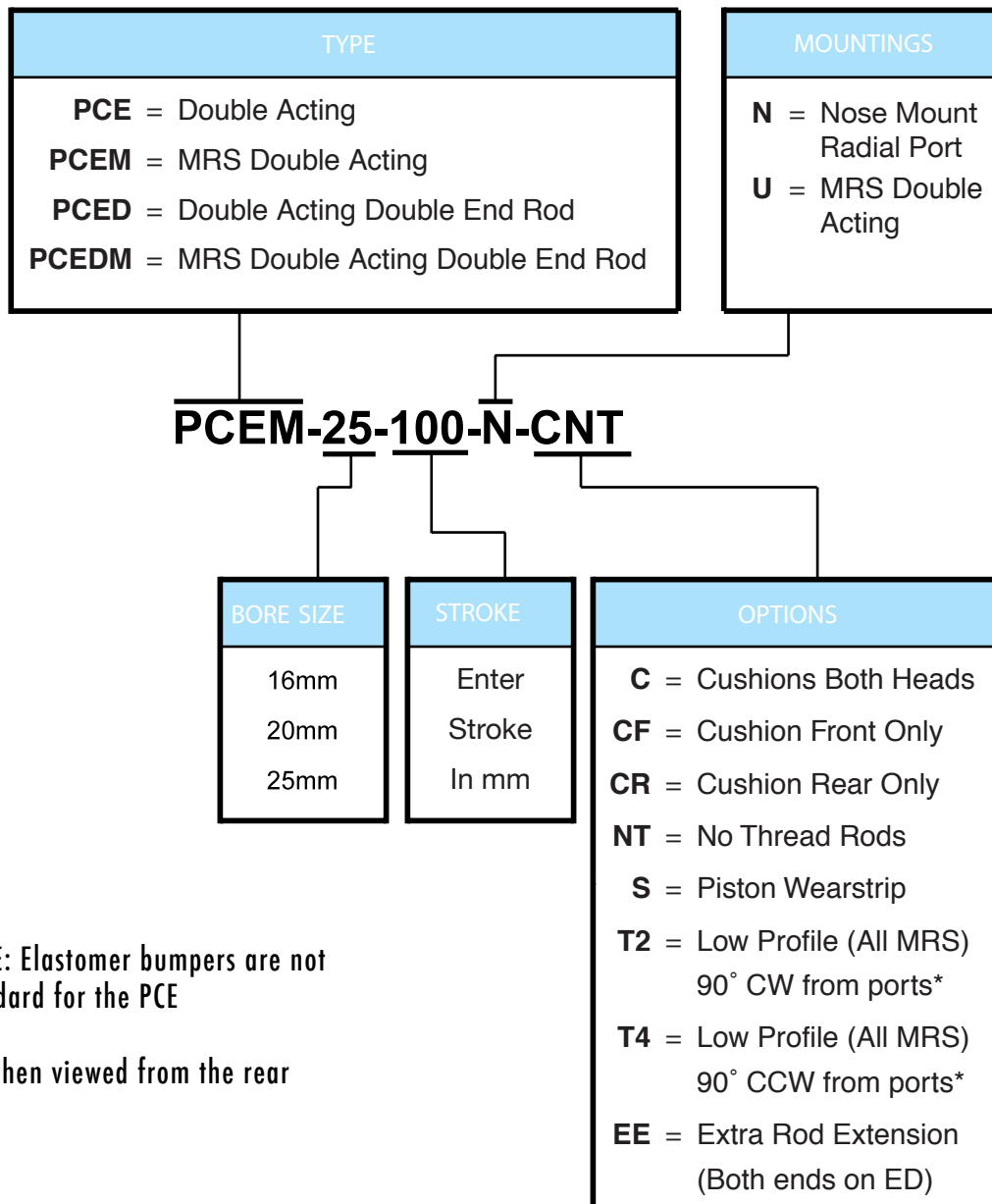

NOTE: Elastomer bumpers are not standard for the PCE

* - when viewed from the rear

The Bimba PCE cylinder has stainless steel body, stainless steel rod and Delrin® end caps.

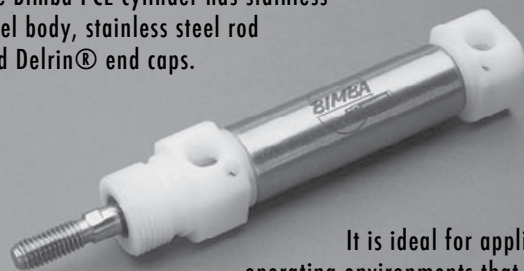

It is ideal for applications operating environments that require exposure to moisture, lubricants and specific solvents.

GENERAL SPECIFICATIONS

	BORE		
	16	20	25
Cushion Length (mm) Each End	18	21	21
Head Material	Delrin® Plastic type 150SA		
Operating Pressure Max. Min.	7 bar 0.5 bar		
Operating Temperature Range	-10°C to +80°C		
Operating Media	Filtered Compressed Air/Lubricated or Non-Lubricated		
Standard Stroke Lengths	1mm to 300mm		
Maximum Stroke Length*	1000mm		
Stroke Tolerance	+1.0mm/-0mm		
Piston Speed	5mm/s to 1000mm/s		
Life Expectancy	3000km		

*Varies according to bore size, please consult your local BIMBA distributor.

WEIGHTS

	Bore		
	16	20	25
Option N	40	77	117
Option U	43	85	126
Type ED	57	116	176
adder per 10mm stroke	5	8	11

Weights (approximate) are for zero stroke, in grams.

NOSEMOUNT-N Option

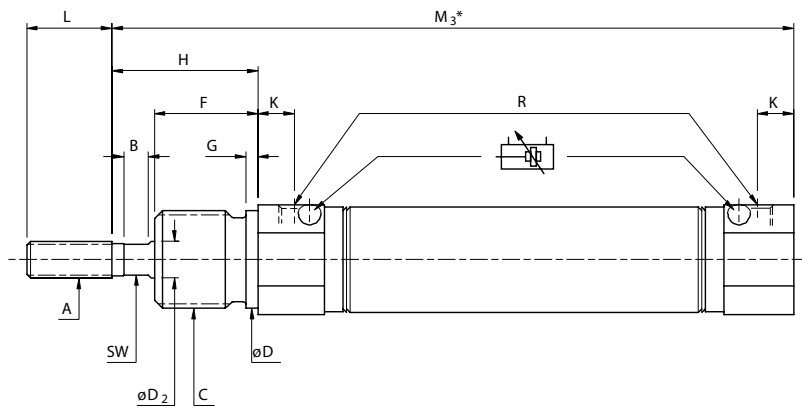

* - Plus stroke
** - Plus 2x stroke

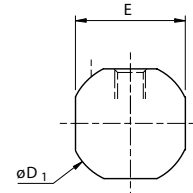

UNIVERSAL MOUNT-U Option

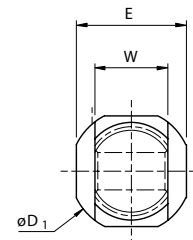
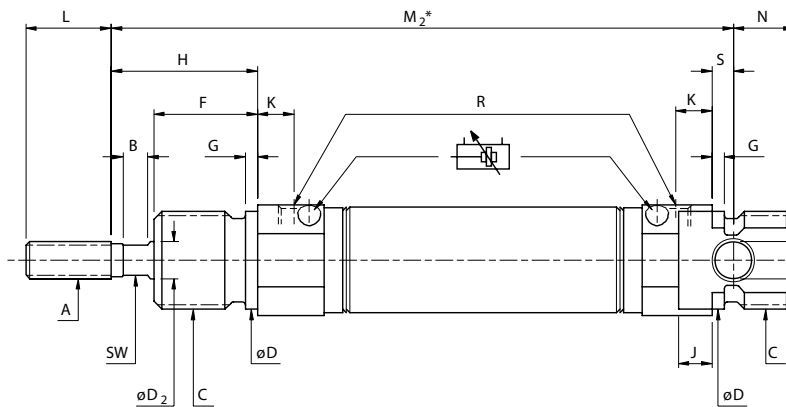

DOUBLE ENDED

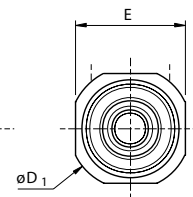
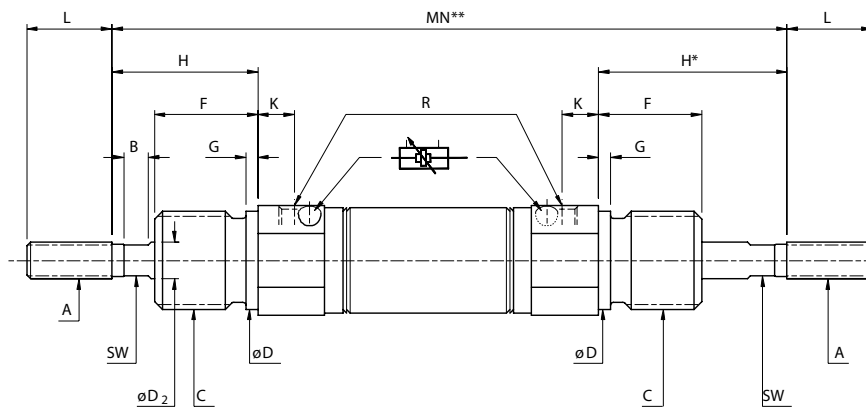

Bore	A ^{6g}	B	C ^{6g}	D	D ₁	D ₂ ^{h8}	E	F	G	H	J	K	L	N	R	S	T ^{H9}	W ^{d13}	SW	M ₂	M ₃	MN
16	M6x1.0	4	M16x1.5	16	20	6	18	17	2	24	5.5	6	14	10	M5x0.8	3.5	6	12	5	84	80.5	104
20	M8x1.25	4	M22x1.5	22	28	8	24	19	3	25	8	8	19	11	G1/8	4	8	16	6	96	92	117
25	M10x1.25	4	M22x1.5	22	30	10	27	22	3	30	6	8	20	11	G1/8	6	8	16	8	106	100	130

PIVOT BRACKET

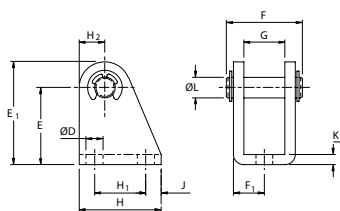

Bore	Type	D	E	E ₁	F	F ₁	G	H	H ₁	H ₂	J	K	L
16	CFB-2-SS	5.6	27	34	24	9	12.5	25	15	7	5	3	6
20,25	CFB-3-SS	6.6	30	40	30.5	12	16.5	32	20	10	6	4	8

FOOT MOUNTING BRACKET

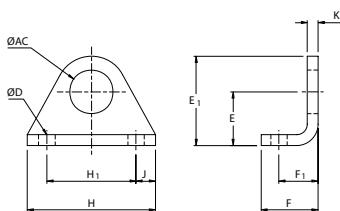

Bore	Type	AC	D	E	E ₁	F	F ₁	H	H ₁	J	K
16	FB-2-SS	16.1	5.6	20	33	20	14	42	32	5	4
20, 25	FB-3-SS	22.1	6.6	25	40	25	17	54	40	7	5

ROD CLEVIS BRACKET

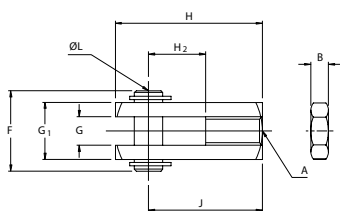

Bore	Type	A	B	F	G	G ₁	H	H ₂	J	L
16	RC-2-SS	M6x1.0	5	16	6	12	31	12	24	6
20	RC-3-SS	M8x1.25	4	20	8	16	42	16	32	8
25	RC-4-SS	M10x1.25	5	26	10	20	52	24	40	10

ROD NUT

Bore	Type	A	B	C
16	RN-2-SS	M6 x 1.0	5	10
20	RN-3-SS	M8 x 1.25	4	13
25	RN-4-SS	M10 x 1.25	5	17

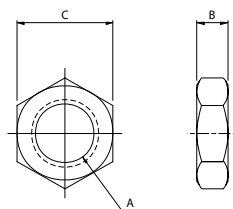

MOUNTING NUT

Bore	Type	A	B	C
16	MN-2-SS	M16 x 1.5	8	24
20, 25	MN-3-SS	M22 x 1.5	10	32