

SECTION 10

VG & VQ PUMPS

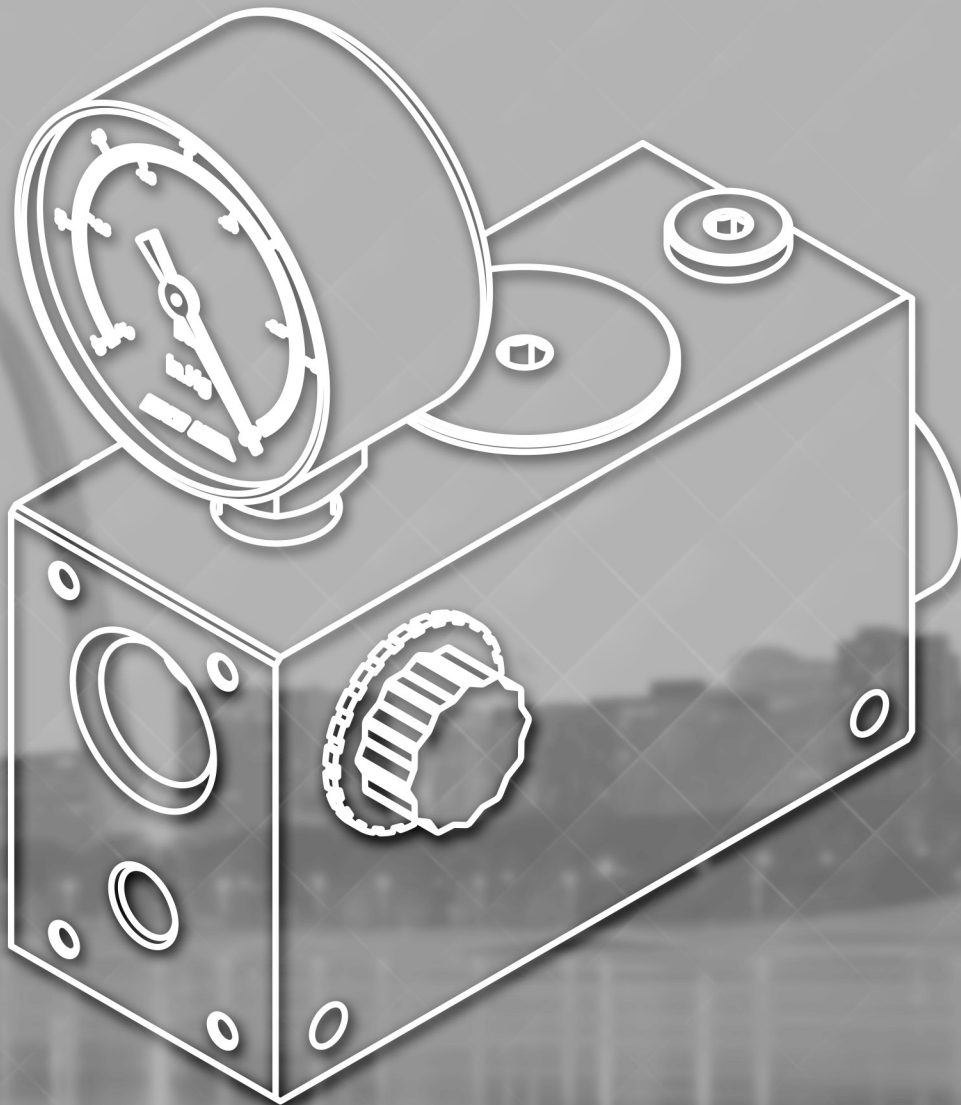

EDCO USA[®]

VG & VQ PUMPS

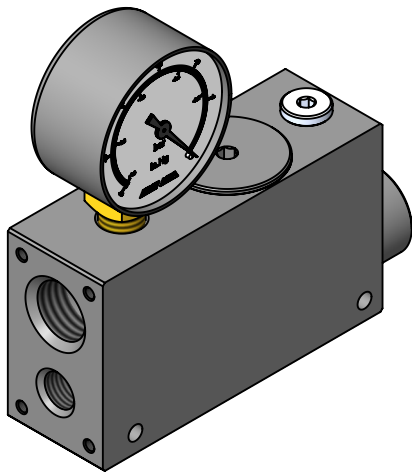

VG PUMPS

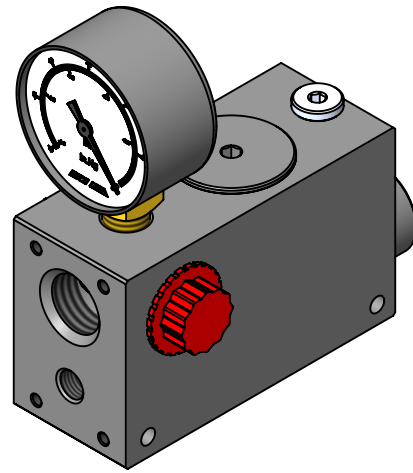

VQ PUMPS

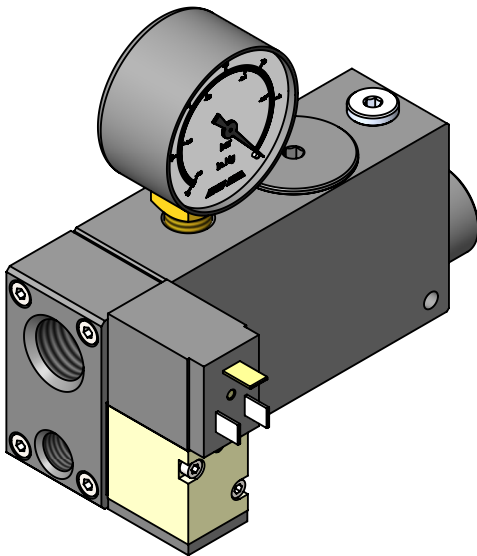

NORMALLY CLOSED SOLENOID

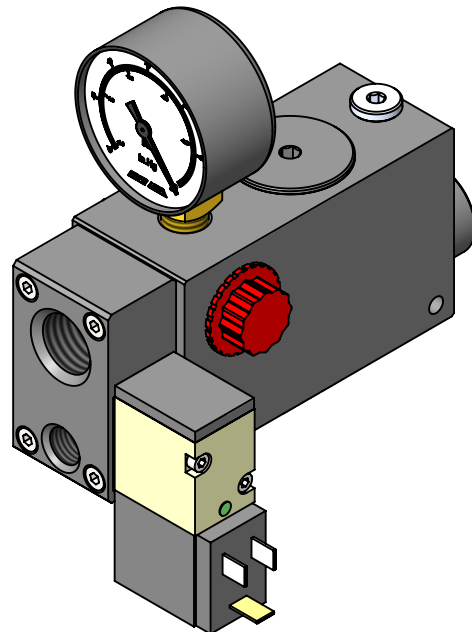

NORMALLY OPEN SOLENOID

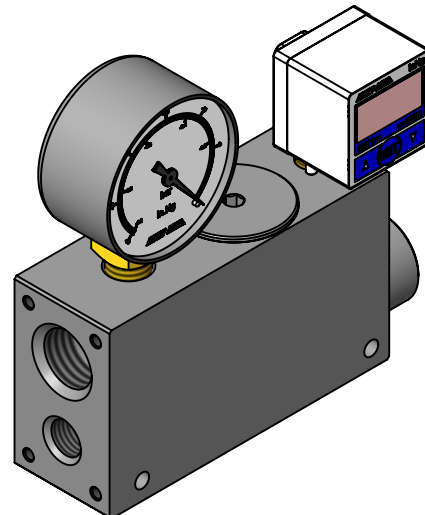

ADDITIONAL OPTIONS

General Information	10:3
VG Pumps	10:4
VQ Pumps	10:5
Options	10:6
Performance	10:7 - 10:8

VG & VQ PUMPS

EDCO VG-Series and VQ-Series pumps have different bodies to make them directly interchangeable with competitors' pumps but utilize the same ejector nozzles so performance is the same regardless of body style. These multi-stage vacuum pumps are designed as direct physical replacements for competitive brand pumps and consistently provide equal or better performance. Customers who were previously limited to a sole source for pumps of this style will now have the option of using higher-quality, all-metal EDCO pumps.

VG-Series and VQ-Series multi-stage pumps are designed as a drop-in interchange for similarly shaped competitors' pumps, but the similarity ends there. Our all-metal pumps feature externally removable, one-piece valves and one-piece, fully-machined aluminum bodies to eliminate loose parts and are manufactured in-house on precision CNC machines to the highest quality standards.

EDCO pumps produce consistently higher performance because of our precision-machined brass nozzles and one-piece valve with over 3X the flow area of competitive designs which provides improved vacuum flow and increased ability to pass ingested debris. EDCO quality control inspectors individually test each and every product before shipment to assure that catalog specifications are met.

An option exclusive to EDCO is an integral solenoid control valve to control on/off which reduces plumbing complexity, fitting costs, and labor as well as increase system reliability by eliminating potential leak points. The solenoid valve is shipped assembled to the pump in the normally-closed (not-passing) mode but can be easily changed to normally-open (passing) mode by simply inverting the valve whenever the application

requires it.

Instead of gang-mounting multiple VG-Series or VQ-Series pumps to a manifold to obtain a higher flow capacity pump, EDCO offers larger multi-stage pumps in Classic Series (3/4" port) or Dual-Base Classic Series (1-1/2" port) styles that are much more compact and easier to maintain.

Competitive catalog data can be misleading, so we highly recommend that you test and validate our pump performance in your system or contact us so that we can provide you with actual comparative test results for competitive pumps. EDCO publishes both large performance graphs and tabulated data to provide accurate tools for system designers. Please contact us for application assistance or for any product questions. EDCO products are designed and manufactured in the USA so we know both their capabilities and limitation. Of course, 3D CAD models are available and most can be downloaded from our website.

EDCO can provide private labeling for OEM customers at no extra charge for those who request it. All that is needed is a DXF or Illustrator file of your logo, part number, and any additional information desired. An initial order of at least five pumps is required but future orders can be any quantity. The laser-engraved white logo and company details will stand out in sharp contrast to the black anodized pump body.

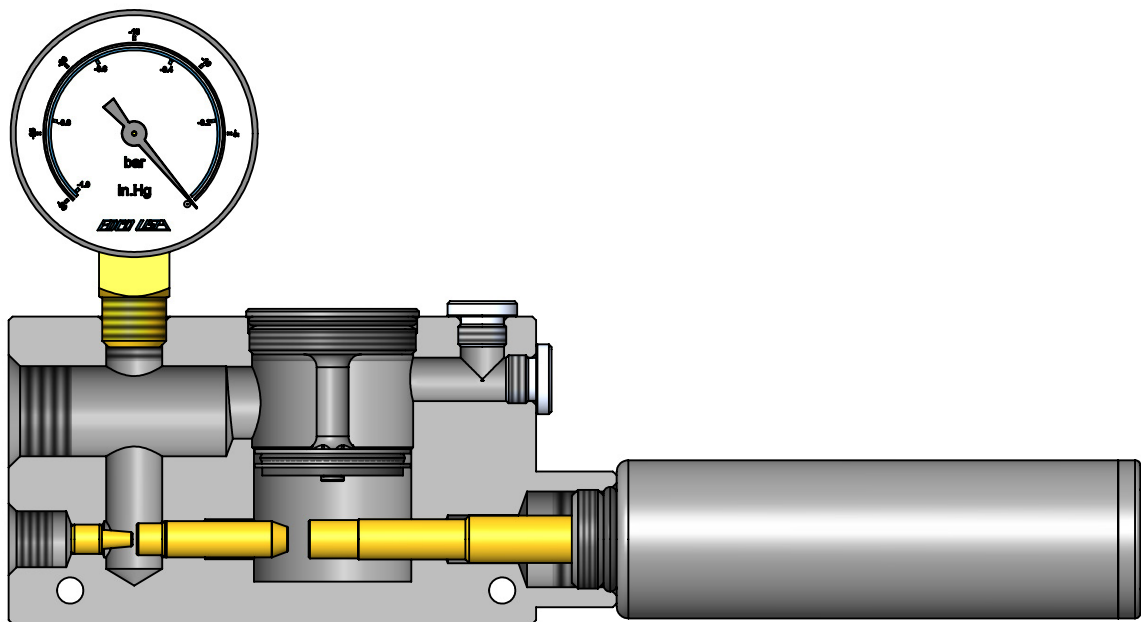

VG PUMPS

CAPACITY	PORTS	SOLENOID ¹	SOLENOID OPTION ¹
065	(Blank) = NPTF	(Blank) = None	(Blank) = No Solenoid
065	G = G Threads	12V = 12 Volt DC	R = Right Side
075		24V = 24 Volt DC	L = Left Side
130			
140			
260			

¹When selecting the solenoid option, you must pick a solenoid voltage. Solenoid will be shipped in the normally closed position

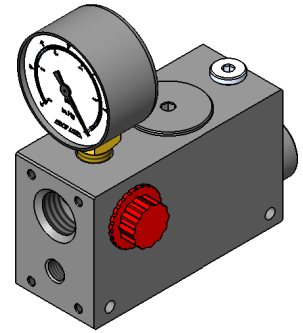

Weight: 1.51 lb [684.9 g]

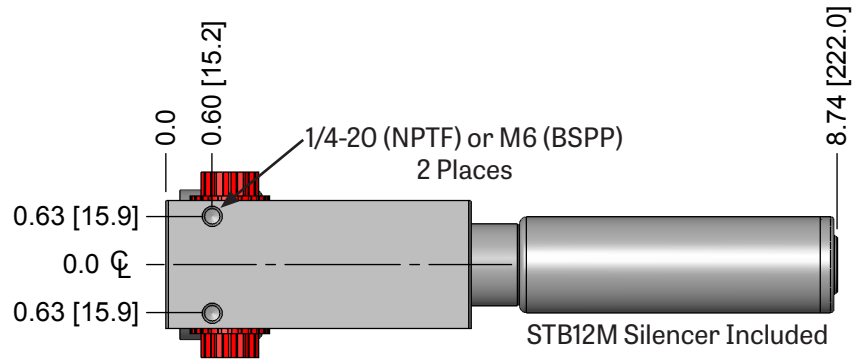
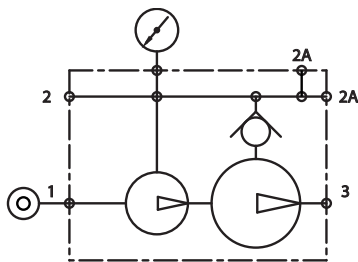
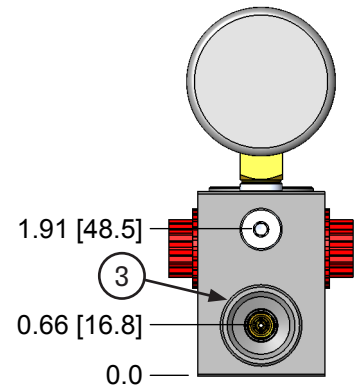
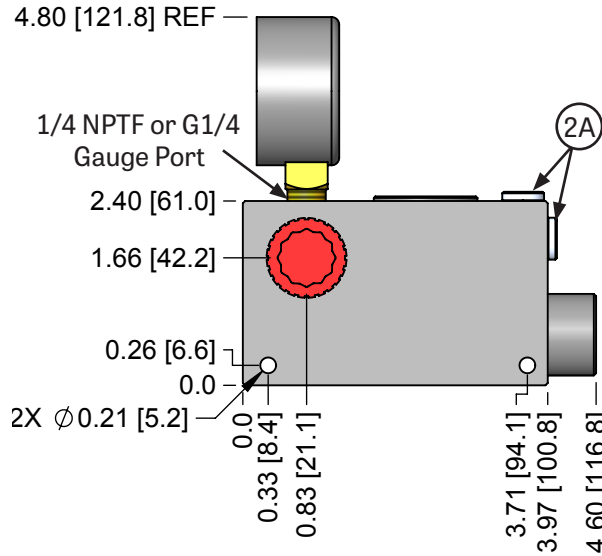
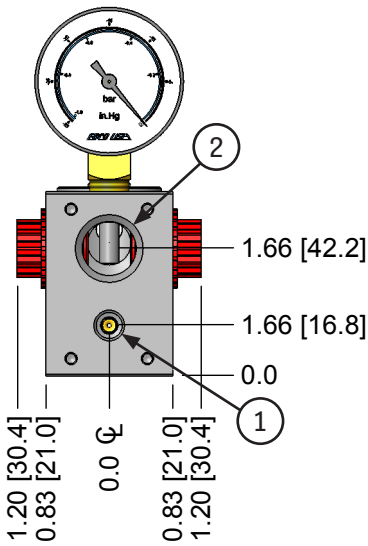
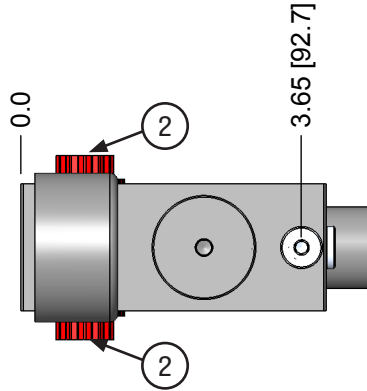

CODE	FUNCTION	NPTF	G
1	Air Supply	G 1/8 NPSF	G 1/8
2	Vacuum - Main	1/2 NPTF	G 1/2
2A	Vacuum - Alternate	G 1/8 NPSF	G 1/8
3	Exhaust	1/2 NPTF	G 1/2

VQ PUMPS

VQ-	CAPACITY	PORTS	SOLENOID ¹	SOLENOID OPTION ¹
	60	(Blank) = NPTF	(Blank) = None	(Blank) = No Solenoid
	60L	G = G Threads	12V = 12 Volt DC	R = Right Side
	120		24V = 24 Volt DC	L = Left Side
	120L			
	180			
	180L			
	240			

¹When selecting the solenoid option, you must pick a solenoid voltage. Solenoid will be shipped in the normally closed position.

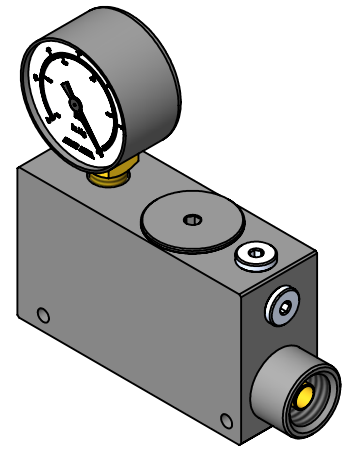

Weight: 1.35 lb [612.3 g]

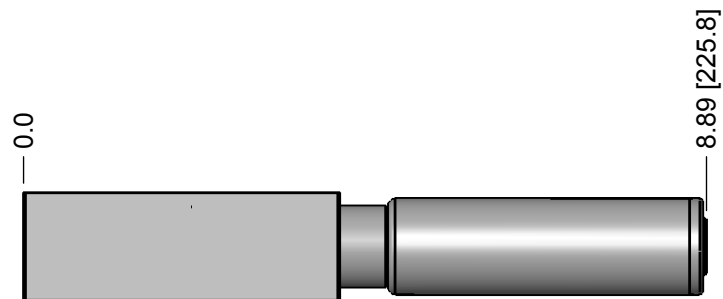
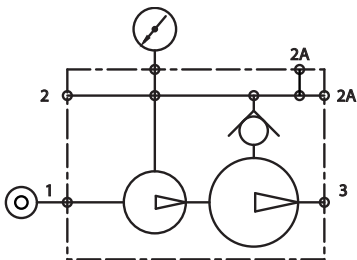
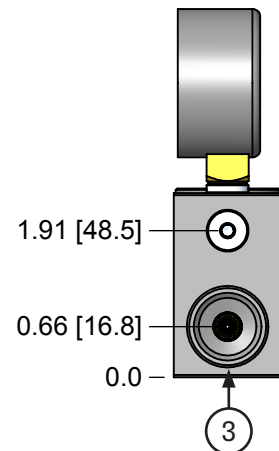
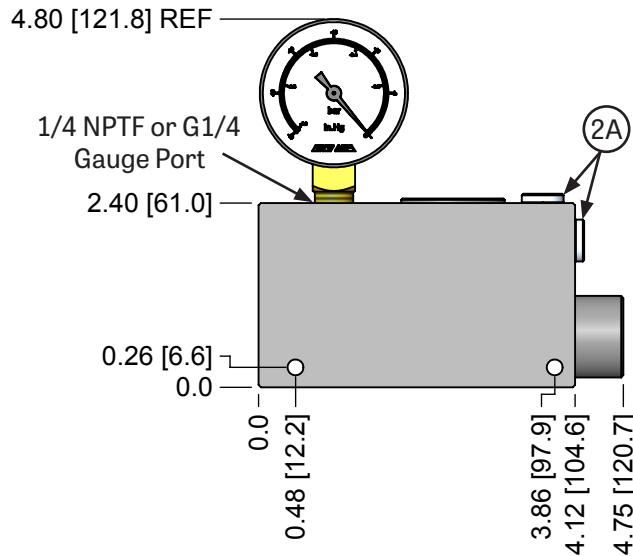
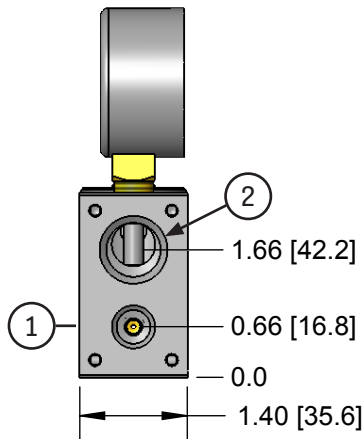
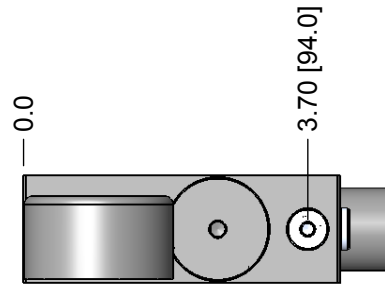

STB12M Silencer Included

CODE	FUNCTION	NPTF	G
1	Air Supply	1/4 NPTF	G 1/4
2	Vacuum - Main	1/2 NPTF	G 1/2
2A	Vacuum - Alternate	G 1/8 NPSF	G 1/8
3	Exhaust	1/2 NPTF	G 1/2

VG & VQ PUMPS SOLENOID OPTION

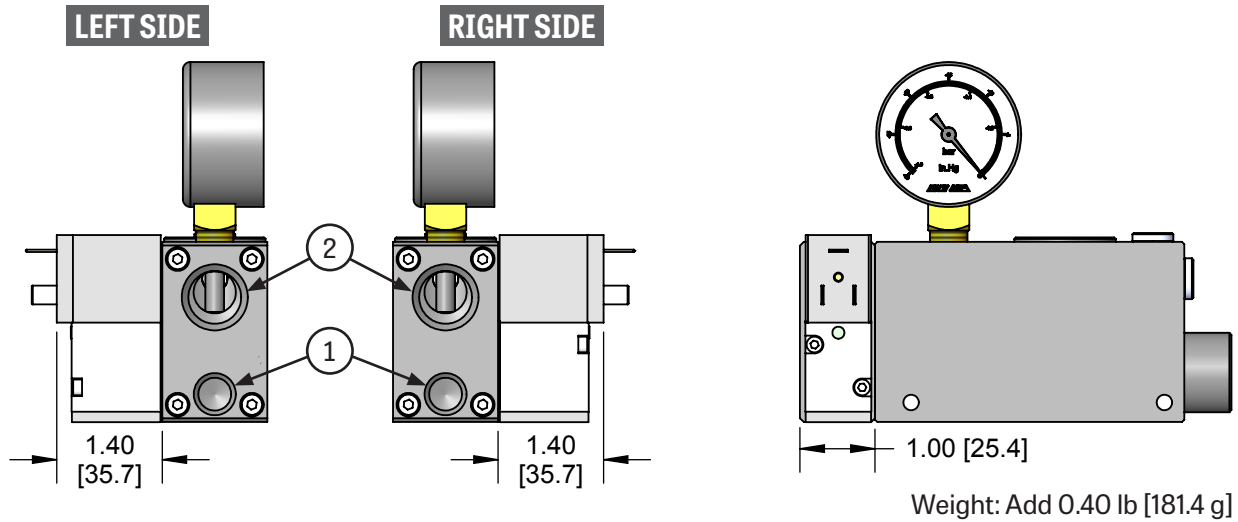

Order DIN T-1 Molded Cord separately:
163-2M31 - 2 M Cord with Varistor & LED, 12-24 VDC

CODE	FUNCTION	NPTF	G
1	Air Supply	1/4 NPTF	G 1/4
2	Vacuum - Main	1/2 NPTF	G 1/2 NPSF

ADDITIONAL OPTIONS

These additional options are shown for demonstration purposes.

Please order any additional items needed separately.

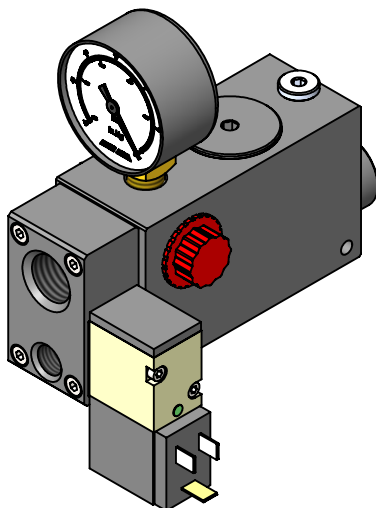

NORMALLY OPEN SOLENOID

Flip solenoid 180°

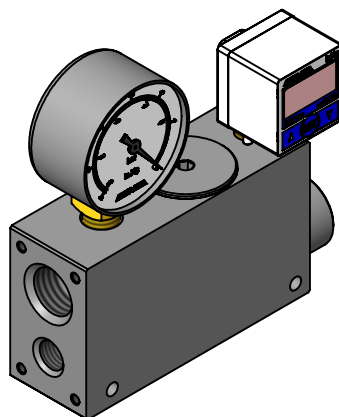

DVN-200 VAC SWITCH

VG & VQ PUMPS PERFORMANCE

Vacuum Flow Index (scfm/ pump scale)

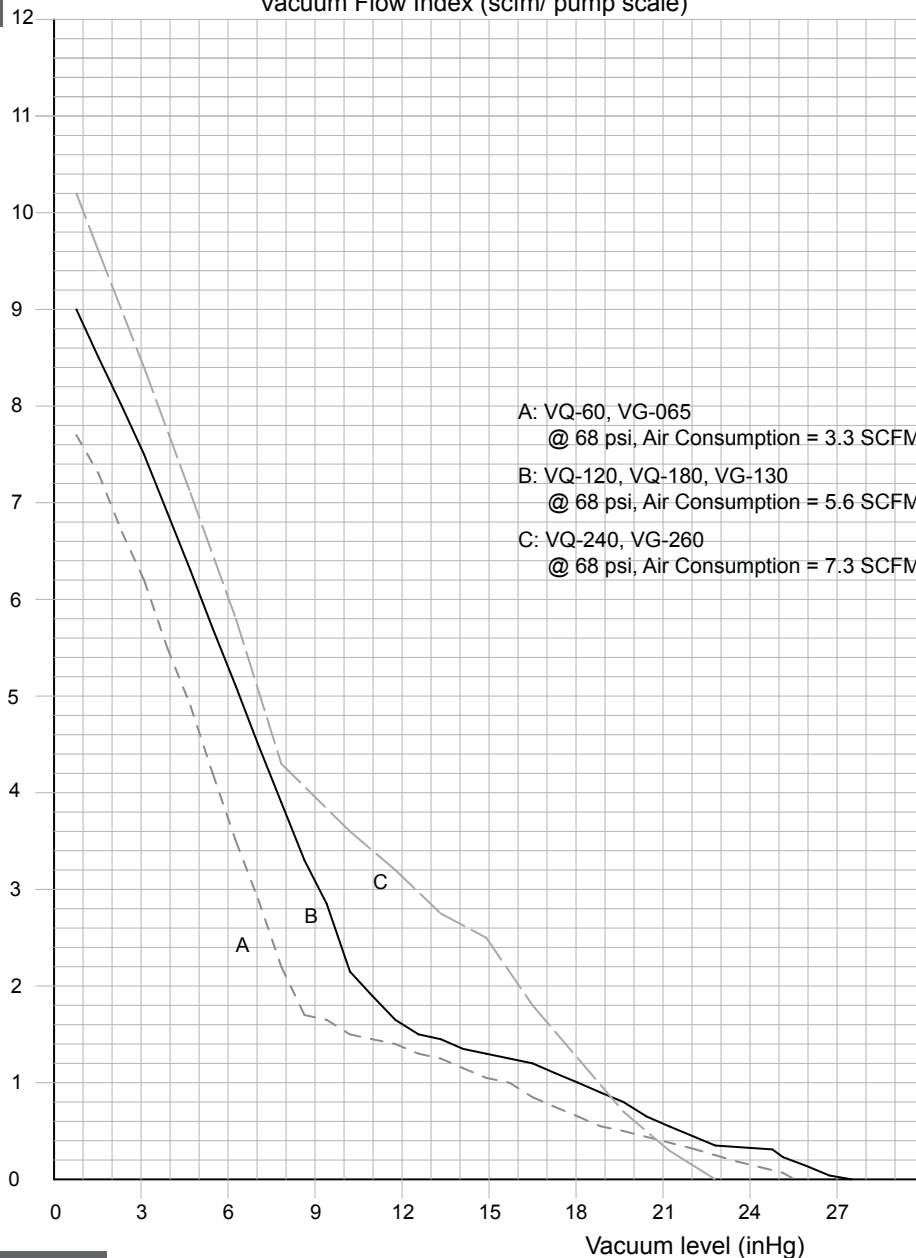

10

VACUUM FLOW - SCFM

MODEL		AIR SUPPLY PSI	CONSUMPTION INDEX SCFM	MAX IN-HG	SCFM VACUUM FLOW AT IN-HG VACUUM LEVEL							
					3	6	9	12	15	18	21	24
VG-065	VQ-60	68	3.3	25.5	6.3	3.8	1.7	1.4	1.0	0.7	0.4	0.15
VG-130	VQ-120	68	5.6	27.5	7.6	5.3	3.1	1.6	1.3	1.0	0.6	0.3
-	VQ-180	68	5.6	27.5	7.6	5.3	3.1	1.6	1.3	1.0	0.6	0.3
VG-260	VQ-240	68	7.3	22.7	8.5	6.0	4.0	3.1	2.5	1.3	0.4	-

EVACUATION TIME - SEC / 100 CU IN

SCFM X 28.32 = nl / m

MODEL		AIR SUPPLY PSI	CONSUMPTION INDEX SCFM	MAX IN-HG	SECONDS TO EVACUATE ONE CU-FT TO IN-HG VACUUM LEVEL							
					3	6	9	12	15	18	21	24
VG-065	VQ-60	68	3.3	25.5	0.65	2.4	3.7	6.9	12.1	20.8	37	46
VG-130	VQ-120	68	5.6	27.5	0.55	1.4	2.9	5.3	9.3	16	28	35
-	VQ-180	68	5.6	27.5	0.55	1.4	2.9	5.3	9.3	16	28	35
VG-260	VQ-240	68	7.3	22.7	0.63	1.3	2.5	4.5	7.6	12.8	13.2	-

sec / 100 cu in X 0.61 = sec / l

All performance data presented is a representation of production pumps but is not a guarantee due to variations in local barometric pressure and of mass produced components.

VG & VQ PUMPS PERFORMANCE

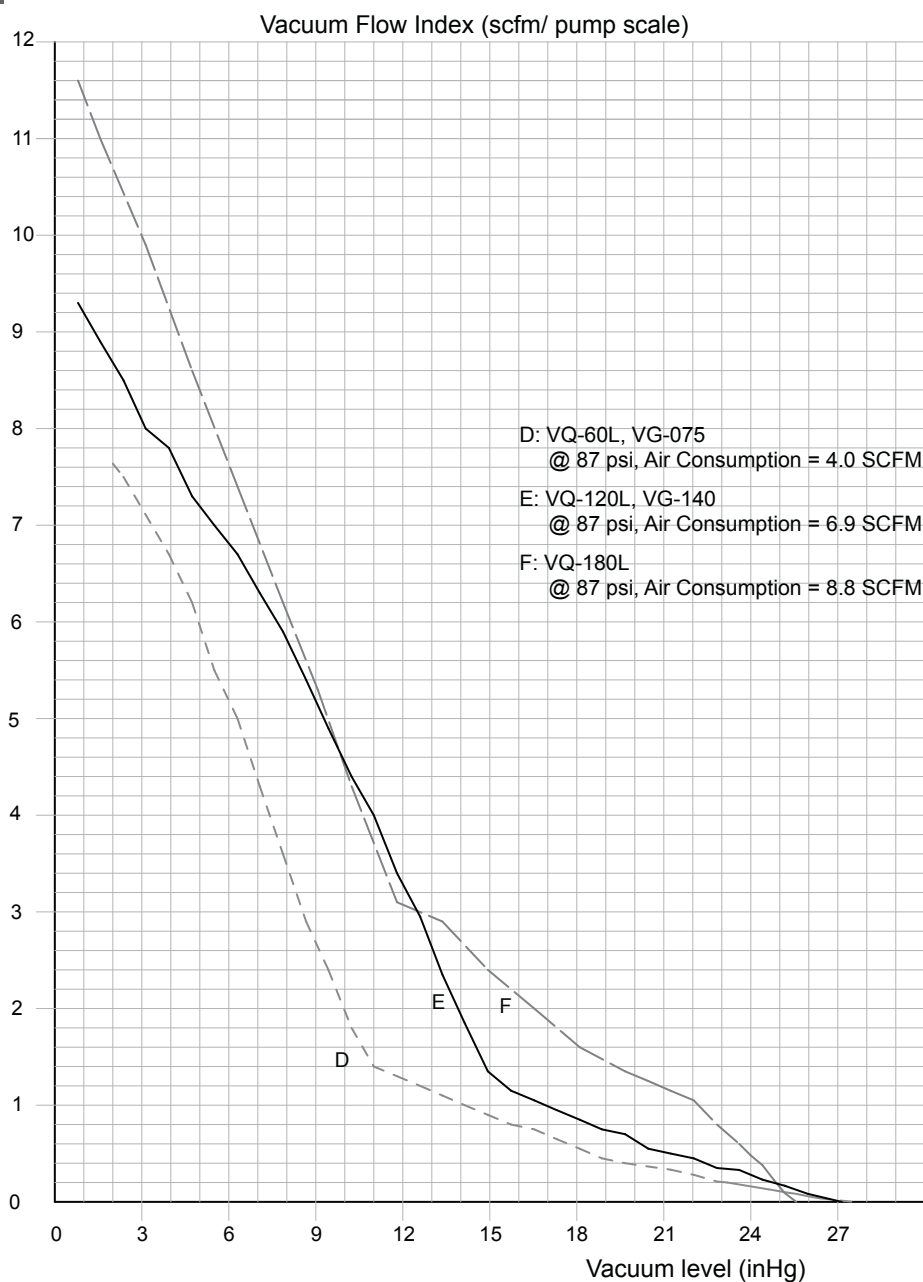

VACUUM FLOW - SCFM

MODEL		AIR SUPPLY PSI	CONSUMPTION INDEX SCFM	MAX IN-HG	SCFM VACUUM FLOW AT IN-HG VACUUM LEVEL							
					3	6	9	12	15	18	21	24
VG-075	VQ-60L	87	4.0	27.5	7.2	5.2	2.7	1.3	0.9	0.6	0.3	0.14
VG-140	VQ-120L	87	6.9	27.0	8.1	6.8	5.1	3.3	1.3	0.9	0.5	0.3
-	VQ-180L	87	8.8	25.5	10.0	7.6	5.4	3.1	2.4	1.6	1.2	0.5

SCFM X 28.32 = nl / m

EVACUATION TIME - SEC / 100 CU IN

MODEL		AIR SUPPLY PSI	CONSUMPTION INDEX SCFM	MAX IN-HG	SECONDS TO EVACUATE ONE CU-FT TO IN-HG VACUUM LEVEL							
					3	6	9	12	15	18	21	24
VG-075	VQ-60L	87	4.0	27.5	0.6	1.5	3.0	5.7	10.2	17.7	32	62
VG-140	VQ-120L	87	6.9	27.0	0.53	1.3	2.5	4.3	7.4	12.8	23	44
-	VQ-180L	87	8.8	25.5	0.42	1.1	2.9	3.7	6.4	10.9	19.2	24

sec / 100 cu in X 0.61 = sec / l

All performance data presented is a representation of production pumps but is not a guarantee due to variations in local barometric pressure and of mass produced components.