

## PNEUMATIC ACTUATORS

### Pneumatic actuators

### Aluminium double acting "DAN" pneumatic actuator (new version)

---

[features](#)

---

[features & benefits](#)

---

[output torque](#)

---

[codes, dimensions and materials](#)

---



### Features

---

#### TECHNICAL FEATURES

Torque from 8 Nm to 8000 Nm.

Mounting flange according to EN ISO 5211

F03 - F04 - F05 - F07 - F10 - F12 - F14 - F16 - F25.

In accordance with EN 15714-3

Rotation angle 90°

Torque: directly proportional to the air supply (see table).

The code numbers after the DA letters, always correspond to the breakaway torque in Nm by 5,6 bar air supply.

ATEX version in conformity with directive 2014/34/EU. Please add YX at the end of the code for ATEX version.

#### WORKING CONDITION

Temperature: from 0 °C to +80 °C; from -20 °C to +80 °C with dry air only. (Special versions: high temperature: -20 °C +150 °C; low temperature: -50 °C +60 °)

Air supply: 5,6 bar; maximum 8,4 bar.

Operating media: compressed filtered air, not necessarily lubricated.

In case of lubricated air, either non detergent oil or NBR compatible oil, must be used.

## Features & benefits

"The image may not be representative of the product"

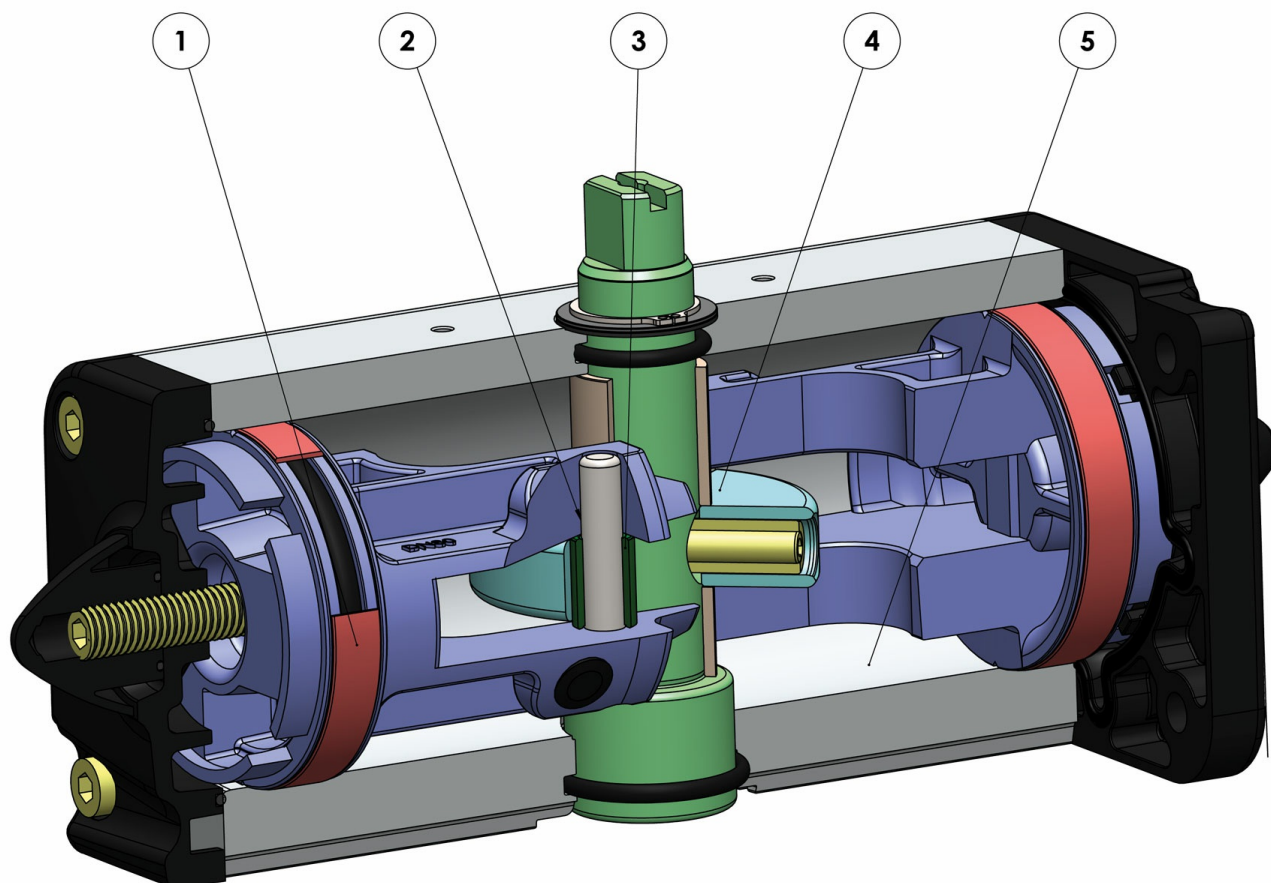

FEATURES AND BENEFITS		
1	Energized and self-lubricated strips	<p>Less friction between piston and cylinder</p> <p>It prevents the bonding of the seal to the cylinder even after long periods of inactivity</p>
2	Slots, bushes and pins made by steel with hardness higher than 50 HRC	Higher resistance to the forces inside the actuator
3	Rolling friction between piston and slot	Less friction
4	Scotch yoke with rolling friction (transforming rotary motion into linear motion using piston and shaft without teeth/gears)	Reduced friction between piston and shaft with consequently less wear on the relevant parts
		Empowered Breakaway Torque (BTO & BTC)
		Smaller volume/size than rack and pinion actuators (with the same torque) therefore less space required for installation
		Less weight than the rack and pinion (-30% kg / Nm), with consequent savings on the construction sizing of the plant/equipment
5	Rolled cylinder	Lower air consumption compared to the rack and pinion actuators (-40% air cm <sup>3</sup> /Nm for Double Acting and -20% air cm <sup>3</sup> /Nm for Spring Return) therefore less load on the compressor or the possibility of using a smaller compressor's size.
		Less wear of the energized ties thanks to the low roughness of the surface (0.15 micron Ra)

	From sizes bigger than DAN15, NAMUR interface for solenoid valve is already integrated.	No need for extra plate.
	100% in-house manufacturing process technology	Maximum control and accuracy in all the stages of the manufacturing process
	ATEX Certificate	Installation is allowed in a potential explosive environment
	SIL 3 Certified	Guarantee of the high level of functional safety.

# Output torque

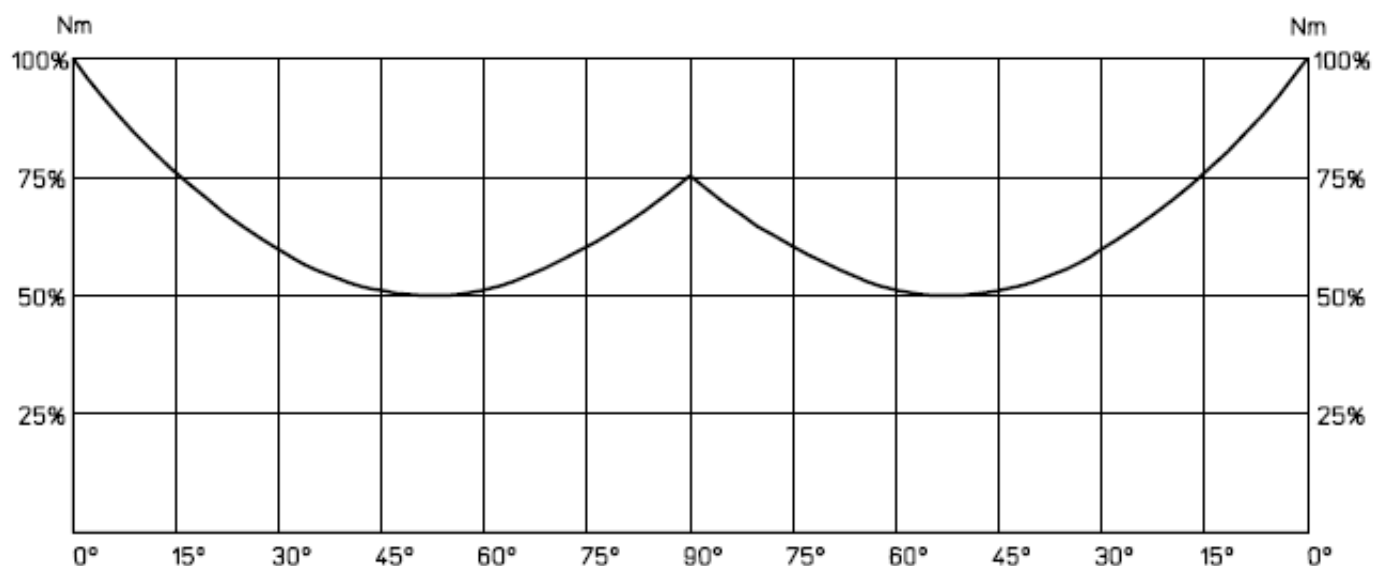

**OUTPUT TORQUE TABLE (Nm)  $\alpha^\circ$  = rotation angle**

SIZE	$\alpha^\circ$	3 bar	4 bar	5 bar	5,6 bar	6 bar	7 bar	8 bar
DA 08	0°	4,3	5,7	7,1	8,0	8,6	10,0	11,4
	45°	2,1	2,8	3,6	4,0	4,3	5,0	5,7
	90°	4,3	5,7	7,1	8,0	8,6	10,0	11,4
DAN 15	0°	8,0	10,7	13,4	15,0	16,1	18,8	21,4
	50°	4,0	5,4	6,7	7,5	8,0	9,4	10,7
	90°	6,0	8,1	10,1	11,3	12,1	14,1	16,1
DAN 30	0°	16,1	21,4	26,8	30,0	32,1	37,5	42,9
	50°	8,0	10,7	13,4	15,0	16,1	18,8	21,4
	90°	12,0	16,1	20,1	22,5	24,1	28,1	32,1
DAN 45	0°	24,0	32,1	40,2	45,0	48,3	56,4	64,2
	50°	12,0	16,2	20,1	22,5	24,0	28,2	32,1
	90°	18,0	24,3	30,3	34,0	36,3	42,3	48,3
DAN 60	0°	32,1	42,9	53,6	60,0	64,3	75,0	85,7
	50°	16,1	21,4	26,8	30,0	32,1	37,5	42,9
	90°	24,1	32,1	40,2	45,0	48,2	56,3	64,3
DAN 106	0°	56,8	75,7	94,6	106	113,6	132,5	151,4
	50°	28,4	37,9	47,3	53,0	56,8	66,3	75,7
	90°	42,9	57,1	71,4	80,0	85,7	100,0	114,3
DAN 120	0°	64,3	85,7	107,1	120,0	128,6	150,0	171,4
	50°	32,1	42,9	53,6	60,0	64,3	75,0	85,7
	90°	48,2	64,3	80,4	90,0	96,4	112,5	128,6
DAN 180	0°	96,0	128,4	160,8	180,0	193,2	225,6	264,8
	50°	48,0	64,8	80,4	90,0	96,0	112,8	128,4
	90°	72,0	97,2	121,2	135,0	145,2	169,2	193,2

DAN 240	0°	128,6	171,4	214,3	240,0	257,1	300,0	342,9
	50°	64,3	85,7	107,1	120,0	128,6	150,0	171,4
	90°	96,4	128,6	160,7	180,0	192,9	225,0	257,1
DAN 360	0°	192,0	256,8	321,6	360,0	386,4	451,2	513,6
	50°	96,0	129,6	160,8	180,0	192,0	225,6	264,8
	90°	144,0	194,4	242,4	270,0	290,4	338,4	386,4
DAN 480	0°	257,1	342,9	428,6	480,0	514,3	600,0	685,7
	50°	128,6	171,4	214,3	240,0	257,1	300,0	342,9
	90°	192,9	257,1	321,4	360,0	385,7	450,0	514,3
DAN 720	0°	384,0	513,6	643,2	720,0	772,8	902,4	1027,2
	50°	192,0	259,2	321,6	360,0	384,0	451,2	529,6
	90°	288,0	388,8	484,8	540,0	580,8	676,8	772,8
DAN 960	0°	514,3	685,7	857,1	960,0	1028,6	1200,0	1371,4
	50°	257,1	342,9	428,6	480,0	514,3	600,0	685,7
	90°	385,7	514,3	642,9	720,0	771,4	900,0	1028,6
DAN 1440	0°	768,0	1027,2	1286,4	1440,0	1545,6	1804,8	2057,4
	50°	384,0	518,4	643,2	720,0	768,0	902,4	1059,2
	90°	576,0	777,6	969,9	1080,0	1161,6	1353,6	1545,6
DAN 1920	0°	1028,6	1371,4	1714,3	1920,0	2057,1	2400,0	2742,9
	50°	514,3	685,8	857,1	960,0	1028,6	1200,0	1371,4
	90°	771,4	1028,6	1285,7	1440,0	1542,9	1800,0	2057,1
DA 2880	0°	1543,0	2057,0	2571,4	2880,0	3085,7	3600,0	4114,3
	50°	771,4	1028,6	1285,7	1440,0	1543,0	1800,0	2057,1
	90°	1157,0	1543,0	1928,6	2160,0	2314,3	2700,0	3085,7
DA 3840	0°	2050,0	2840,0	3425,0	3840,0	4110,0	4880,0	5485,0
	50°	1025,0	1370,0	1710,0	1920,0	2055,0	2400,0	2740,0
	90°	1540,0	2055,0	2570,0	2880,0	3085,0	3600,0	4014,0
DA 5760	0°	3085,7	4114,3	5143,0	5760,0	6171,4	7200,0	8228,6
	50°	1542,9	2057,0	2571,4	2880,0	3085,7	3600,0	4114,3
	90°	2314,3	3085,7	3857,1	4320,0	4628,6	5400,0	6171,4
DA 8000	0°	4285,7	5714,3	7142,9	8000,0	8571,4	10000,0	-
	50°	2142,9	2857,1	3571,4	4000,0	4285,7	5000,0	-
	90°	3214,3	4285,7	5357,1	6000,0	6428,6	7500,0	-



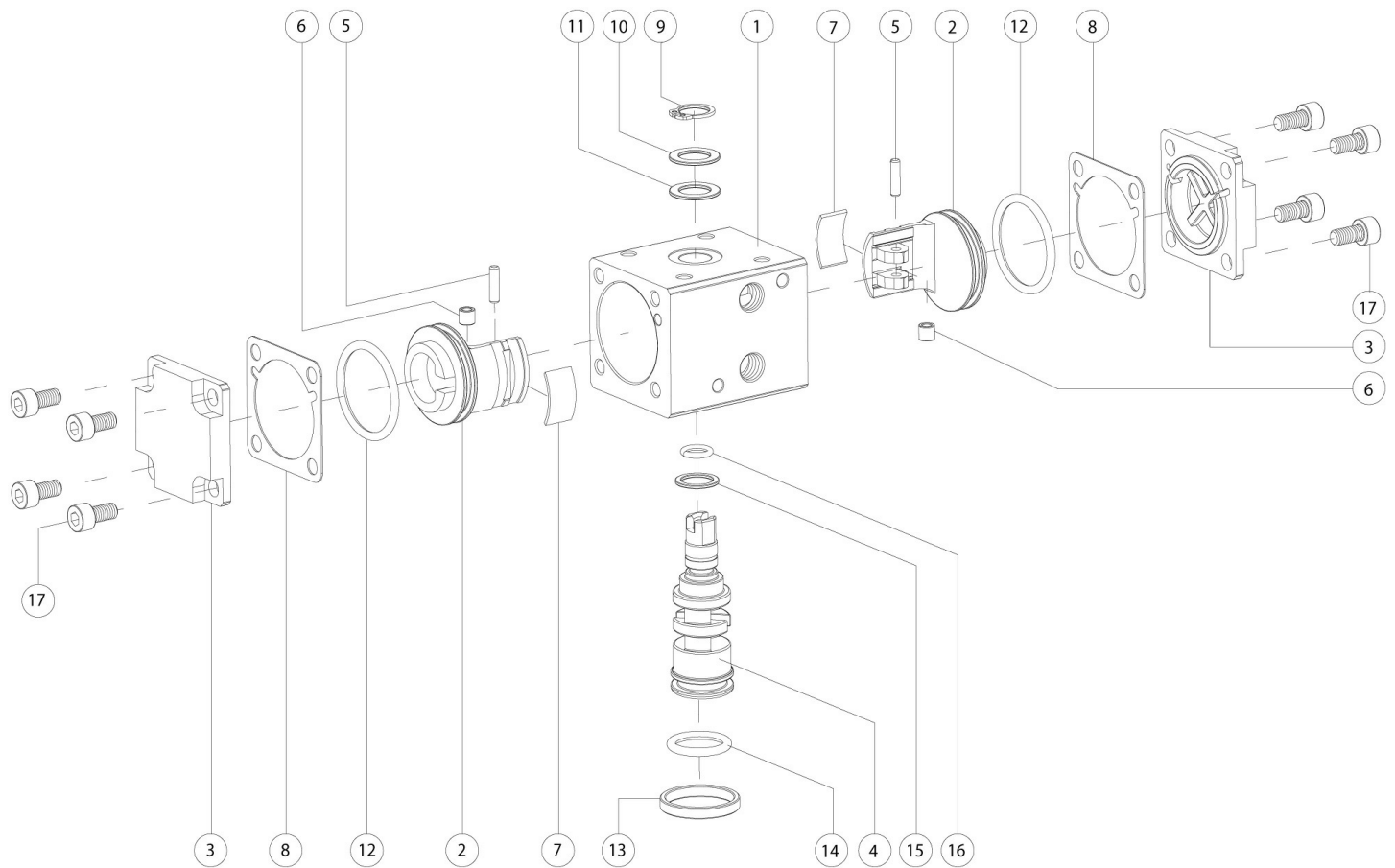

#### MATERIALS SPECIFICATION

Pos	Denomination	Q.TA' Q.ty	Material
1	Cylinder	1	Aluminium alloy
2	Piston	2	Aluminium alloy
3	Cap DA	2	Aluminium alloy
4	Shaft	1	Steel alloy
5	Sleeve	2	Steel alloy
6	Bush	2	Steel alloy
7*	Support band	2	Acetalic resins
8*	O-ring	2	NBR
9	Seeger	1	Stainless steel
10	Washer	1	Stainless steel
11*	Ext. support ring	1	Acetalic resins
12*	O-ring	2	NBR
13	Center ring F03	1	Alluminium alloy
14*	O-ring	1	FKM
15*	Int.support ring	1	Acetalic resins
16*	O-ring	1	FKM
17	Screw	8	Stainless steel

\*Components of spare part kit

# Codes, dimensions and materials - DAN15

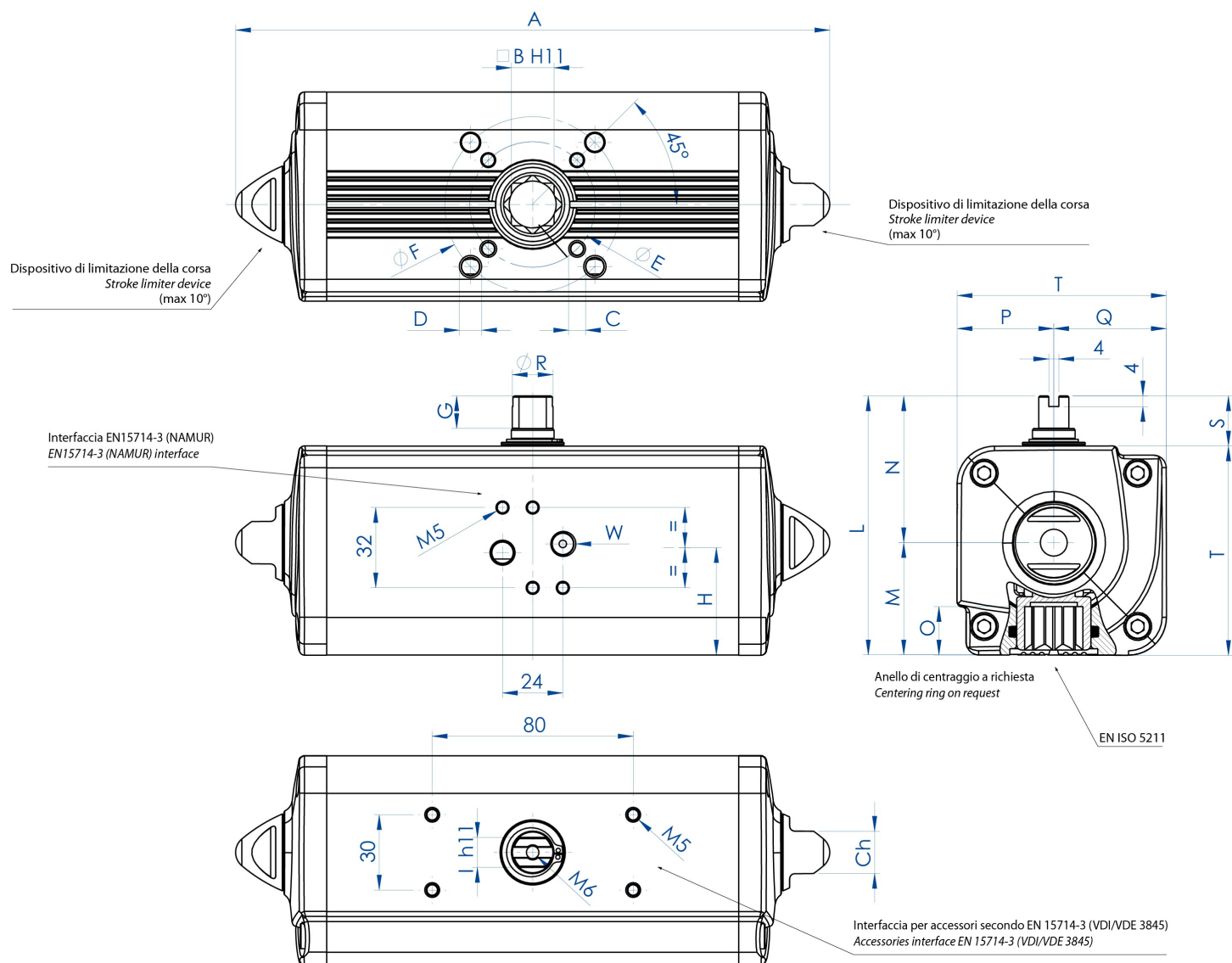

## DATA TABLE

Code	DAN0015411S	DAN0015412S
Spare seals	KGGI0012	
<b>Size</b>	<b>DAN 15</b>	
ISO	F03	F04
A	159,1	159,1
B	11	11
C x depth	M5x8	M5x8
D x depth	-	-
E	36	42
F	-	-
G	10	10
H	26,8	26,8
I	8	8
L	72,2	72,2
M	28	28



N	44,2	44,2
O	13,2	13,2
P	24,2	24,2
Q	28	28
R	9,2	9,2
S	20	20
T	52,2	52,2
W (gas)	1/8"	1/8"
Ch	13	13
Weight (Kg)	0,75	0,75
Air (dm3/cycle)	0,08	0,08

H = CENTER OF PLATE'S FIXING

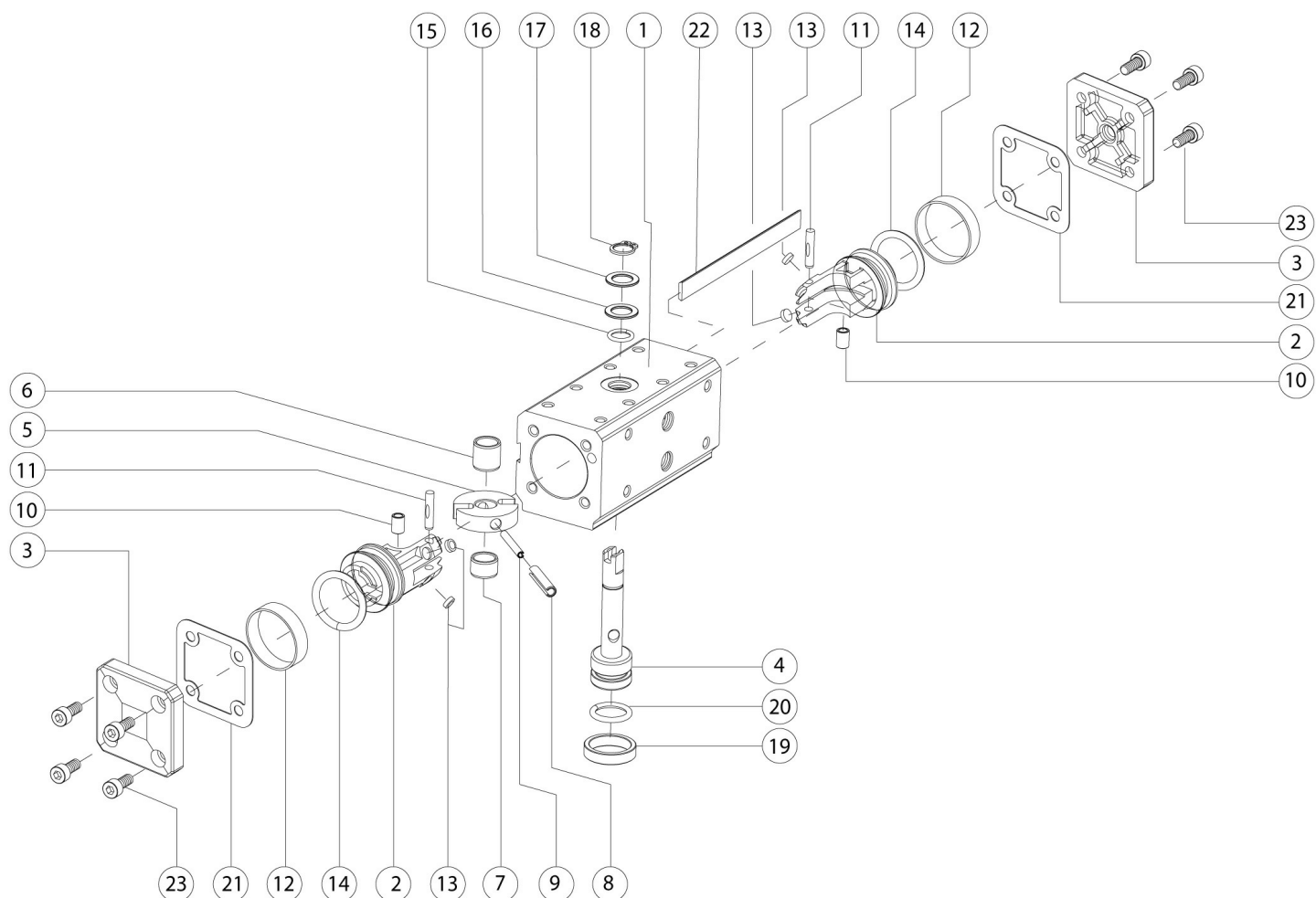

### MATERIALS SPECIFICATION

Pos	Denomination	Q.ty	Material
1	Cylinder	1	Aluminium alloy
2	Piston	2	Aluminium alloy
3	Cap DA	2	Aluminium alloy
4	Shaft	1	Stainless steel
5	Scotch yoke	1	Steel alloy
6	Bush	1	Acetalic resins

7	Bush	1	Acetalic resins
8	Ext. elastic pin	1	Steel alloy
9	Int. elastic pin	1	Steel alloy
10	Bush	2	Steel alloy
11	Sleeve	2	Steel alloy
12*	Dynamic seal	2	Polyurethan
13*	suppoert disk	4	Carbo-graphite filled PTFE
14*	O-ring	2	NBR
15*	O-ring	1	Viton
16*	Ext. support ring	1	Acetalic resins
17	Washer	1	Stainless steel
18	Seeger	1	Stainless steel
19	Center ring F03	1	Aluminium alloy
20*	O-ring	1	Viton
21*	Gasket	2	AFM-38
22	Plate	1	Aluminium
23	Screw	8	Stainless steel

\*Components of spare part kit

# Codes, dimensions and materials - DAN30 - DAN360

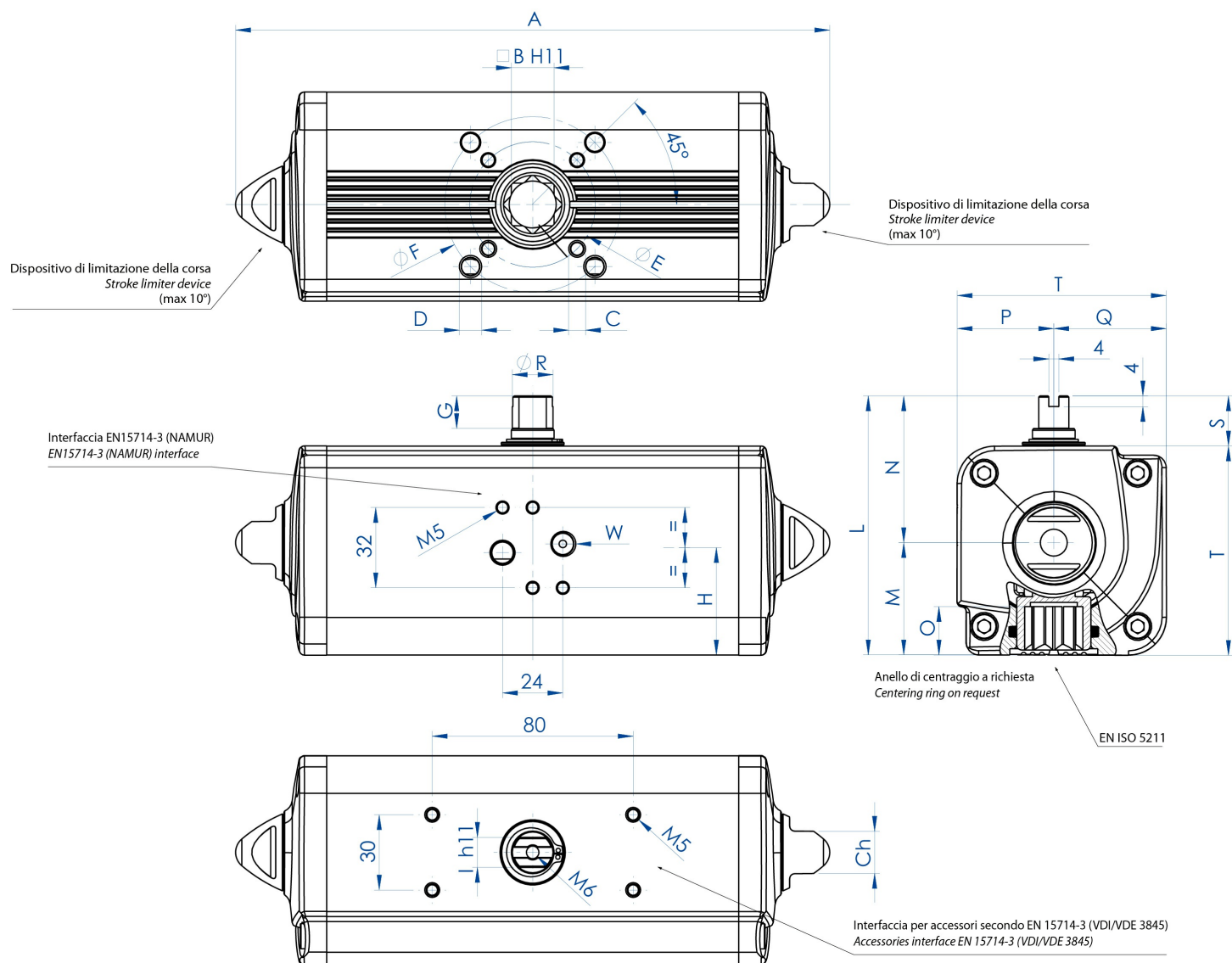

## DATA TABLE

Code	DAN0030411S	DAN0030412S	DAN0045411S	DAN0045412S	DAN0060411S	DAN0060412S
Spare seals	KGGI0014		KGGI0015		KGGI0016	
Size	DAN30		DAN45		DAN60	
ISO	F03/F05	F04	F04	F03/F05	F04	F05/F07
A	174,3	174,3	188,5	188,5	198,1	198,1
B	11	11	11	11	14	14
C x depth	M5x8	M5x8	M5x8	M5x8	M5x8	M6x9
D x depth	M6x9	-	M6x9	-	-	M8x12
E	36	42	36	42	42	50
F	50	-	50	-	-	70
G	10	10	13	13	13	13
H	30,3	30,3	32,5	32,5	35,7	35,7
I	9	9	10	10	10	10
L	79,2	79,2	84,5	84,5	90,4	90,4
M	31,5	31,5	34,5	34,5	37,7	37,7

N	47,7	47,7	50	50	52,7	52,7
O	13,2	13,2	13,2	13,2	16,5	16,5
P	27,7	27,7	30	30	32,7	32,7
Q	31,5	31,5	34,5	34,5	37,7	37,7
R	10,9	10,9	12,7	12,7	14,5	14,5
S	20	20	20	20	20	20
T	59,2	59,2	64,5	64,5	70,4	70,4
W (gas)	1/8"	1/8"	1/8"	1/8"	1/8"	1/8"
Ch	13	13	13	13	13	13
Weight (Kg)	1	1	1,2	1,2	1,6	1,6
Air (dm3/cycle)	0,15	0,15	0,22	0,22	0,3	0,3

H = CENTER OF PLATE'S FIXING

Code	DAN0106411S	DAN0120411S	DAN0180411S	DAN0240411S	DAN0360411S
Spare seals	KGGI0060	KGGI0018	KGGI0019	KGGI0020	KGGI0021
<b>Size</b>	<b>DAN106</b>	<b>DAN120</b>	<b>DAN180</b>	<b>DAN240</b>	<b>DAN360</b>
ISO	F05/F07	F05/F07	F07/F10	F07/F10	F07/F10
A	237,1	257,4	289,9	313,6	339,3
B	17	17	22	22	22
C x depth	M6X9	M6X9	M8X12	M8X12	M8X12
D x depth	M8X12	M8X12	M10X15	M10X15	M10X15
E	50	50	70	70	70
F	70	70	102	102	102
G	13	13	16	17	19
H	42,8	44,8	54,5	58,1	60
I	12	12	15	15	19
L	103,3	107	137,5	141,1	148
M	44,8	46,8	56,5	60,1	62
N	58,5	60,2	81	81	86
O	19,3	19,3	24,8	24,8	24,3
P	38,5	40,2	51	51	56
Q	44,8	46,8	56,5	60,1	62
R	16,2	18	20,2	22,5	22,5
S	20	20	30	30	30
T	83,3	87	107,5	111,1	118
W (gas)	1/8"	1/8"	1/8"	1/8"	1/8"
Ch	17	22	22	22	22
Weight (Kg)	2,5	2,6	4,6	5,4	6,5
Air (dm3/cycle)	0,55	0,59	0,95	1,3	1,8

H = CENTER OF PLATE'S FIXING

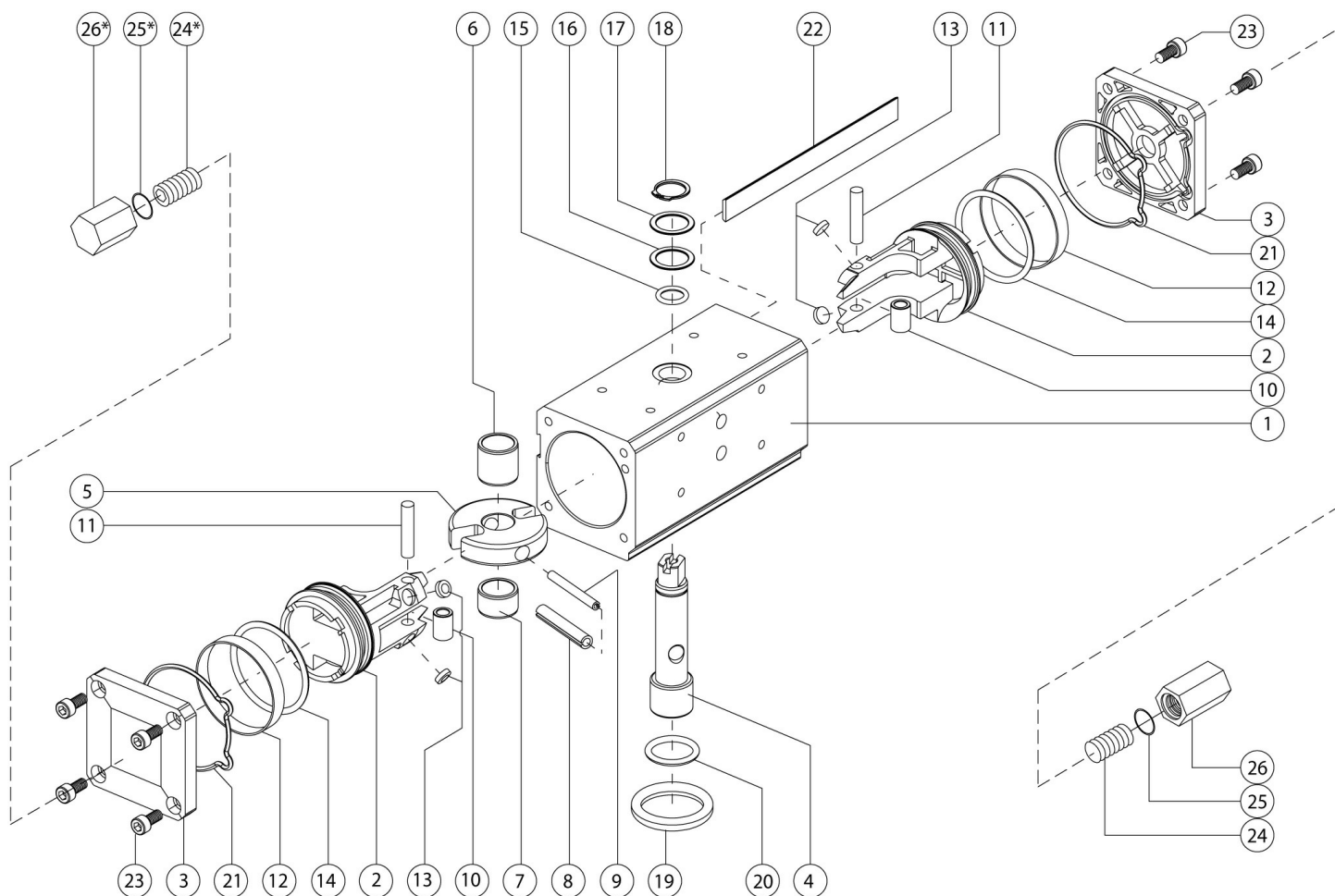

#### MATERIALS SPECIFICATION

Pos	Denomination	Q.ty	Material
1	Cylinder	1	Aluminium alloy
2	Piston	2	Aluminium alloy
3	Cap DA	2	Aluminium alloy
4	Shaft	1	Stainless steel
5	Scotch yoke	1	Steel alloy
6	Bush	1	Resina acetlica Acetalic resins
7	Bush	1	Resina acetlica Acetalic resins
8	Ext. elastic pin	1	Steel alloy
9	Int. elastic pin	1	Steel alloy
10	Bush	2	Steel alloy
11	Sleeve	2	Steel alloy
12**	Dynamic seal	2	Polyurethan
13**	suppoert disk	4	Carbo-graphite filled PTFE
14**	O-ring	2	NBR
15**	O-ring	1	FKM
16**	Ext.support ring	1	Resina acetlica Acetalic resins
17	Washer	1	Stainless steel
18	Seeger	1	Stainless steel
19	Center ring F03	1	Aluminium alloy

20**	O-ring	1	FKM
21**	O-ring	2	NBR
22	Plate	1	Aluminium
23	Screws	8	Stainless steel
24*	Grub screws	2	Stainless steel
25*	O-ring	2	Gomma nitrilica NBR
26*	Adjusting nut	2	Aluminium alloy

\* Actuator with regulation Code: DA\_\_\_411

\*\*Components of spare part kit

# Codes, dimensions and materials - DAN480

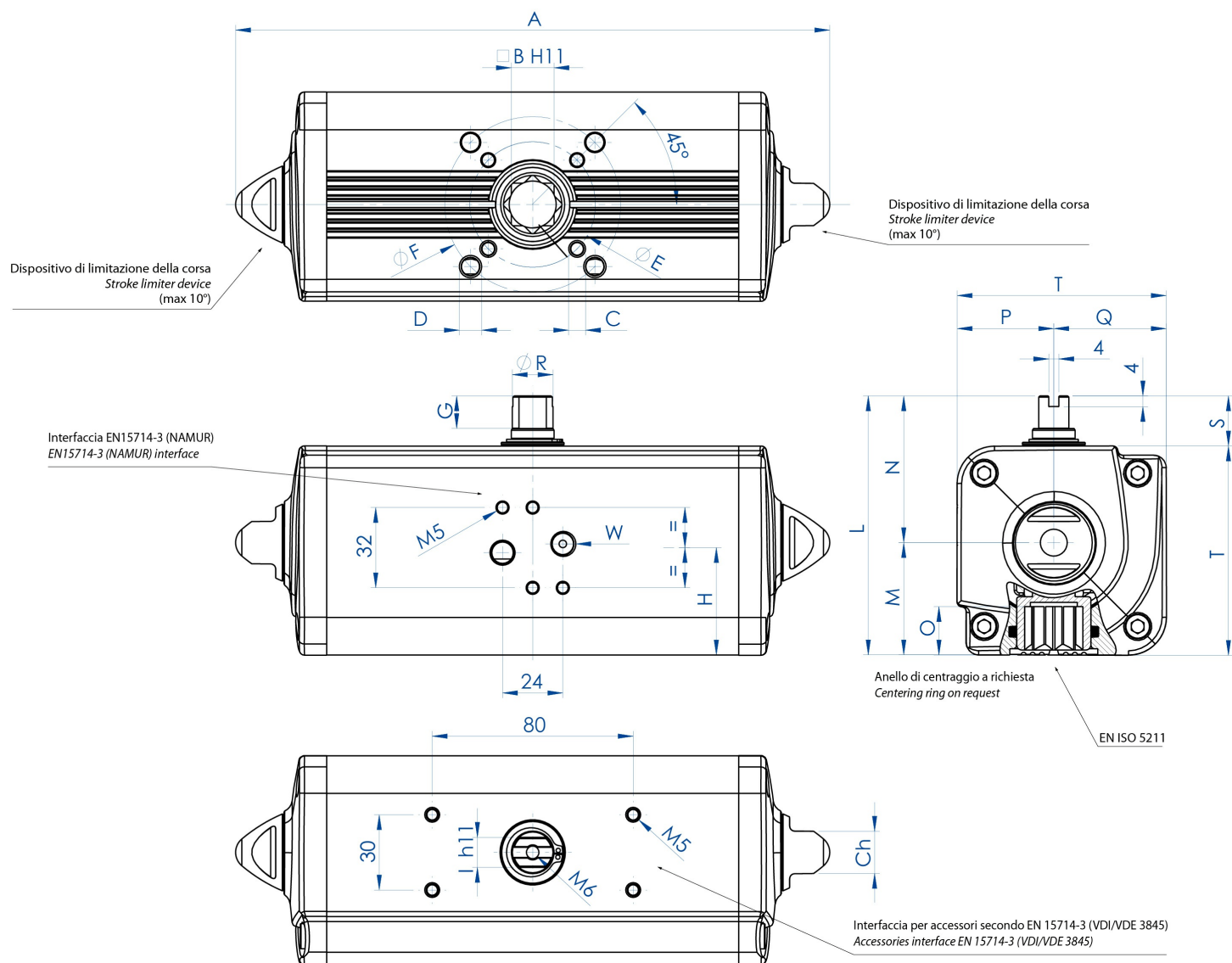

## DATA TABLE

Code	DAN0480411S
Spare seals	KGGI0022
<b>Size</b>	<b>DAN480</b>
ISO	F10/F12
A	387,7
B	27
C x depth	M10x15
D x depth	M12x18
E	102
F	125
G	19
H	57,4
I	19
L	164,9
M	72,9

N	92
O	29,5
P	62
Q	72,9
R	29
S	30
T	134,9
W (Gas)	1/4"
Ch	27
Weight (Kg)	9,6
Air (dm3/cycle)	2,6

H = CENTER OF PLATE'S FIXING

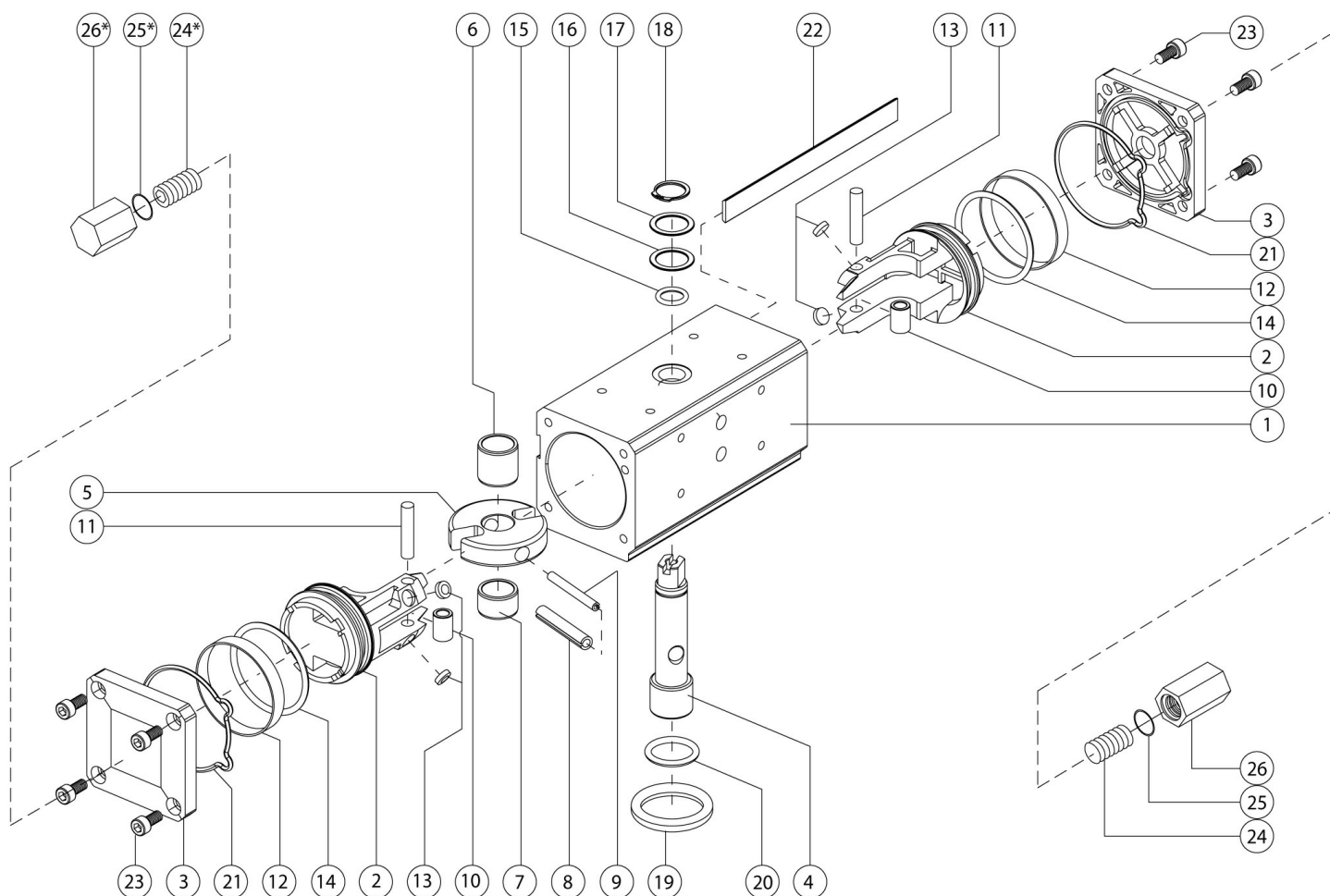

**MATERIALS SPECIFICATION**

Pos	Denomination	Q.ty	Material
1	Cylinder	1	Aluminium alloy
2	Piston	2	Aluminium alloy
3	Cap DA	2	Aluminium alloy
4	Shaft	1	Stainless steel
5	Scotch yoke	1	Steel alloy
6	Bush	1	Acetalic resins
7	Bush	1	Acetalic resins



8	Ext. elastic pin	1	Steel alloy
9	Int. elastic pin	1	Steel alloy
10	Bush	2	Steel alloy
11	Sleeve	2	Steel alloy
12**	Dynamic seal	2	Polyurethan
13**	suppoert disk	4	Carbo-graphite filled PTFE
14**	O-ring	2	NBR
15**	O-ring	1	Viton
16**	Ext. support ring	1	Acetalic resins
17	Washer	1	Stainless steel
18	Seeger	1	Stainless steel
19	Center ring F03	1	Aluminium alloy
20**	O-ring	1	Viton
21**	Gasket	2	AFM-38
22	Plate	1	Aluminium
23	Screw	8	Stainless steel
24*	Grub screw	2	Stainless steel
25*	O-ring	2	NBR
26*	Adjusting nut	2	Alluminium alloy
* Actuator with regulation Code: DA__411			
**Components of spare part kit			

# Codes, dimensions and materials - DAN720

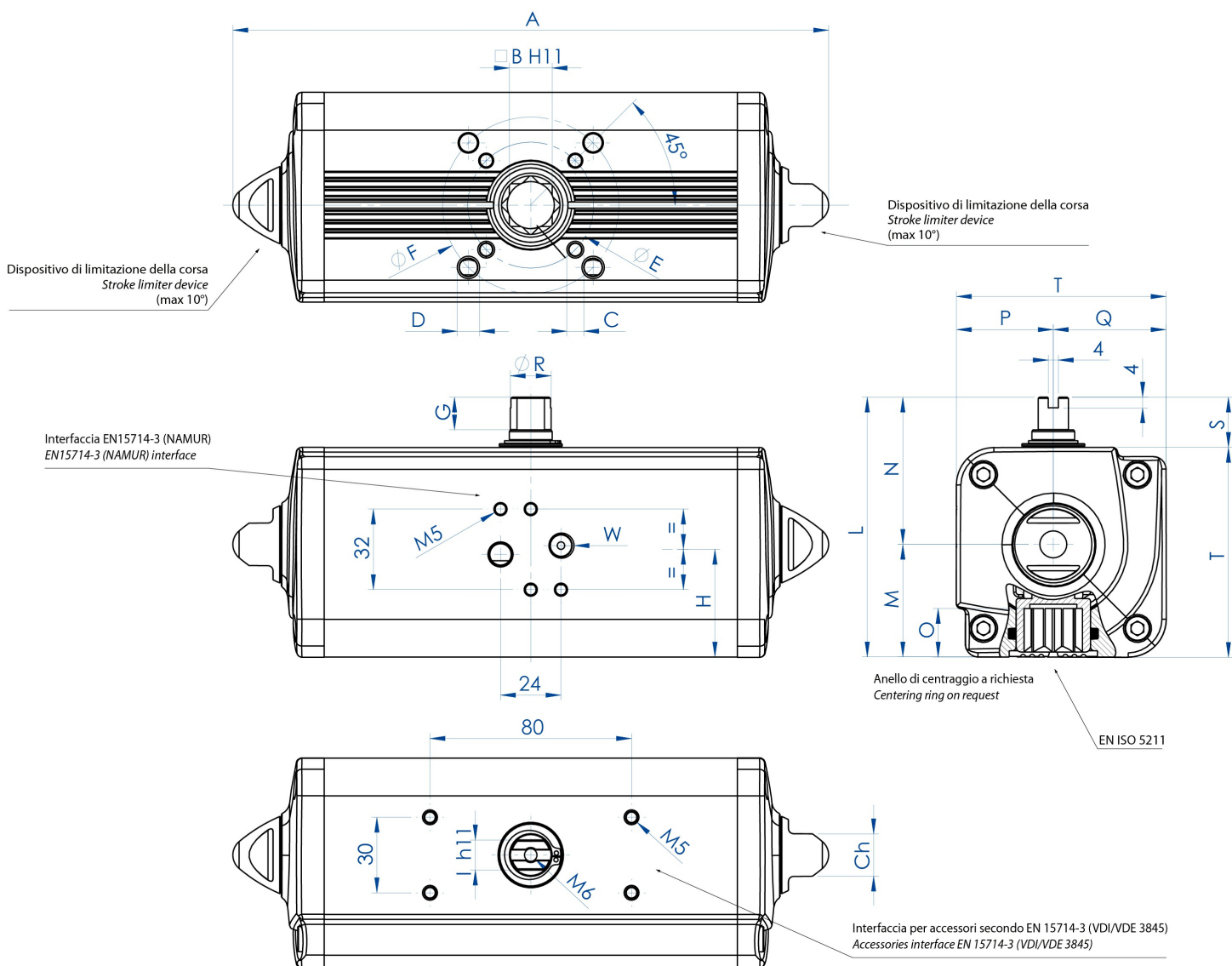

## DATA TABLE

Code	DAN0720411S
Spare seals	KGGI0023
<b>Size</b>	<b>DAN720</b>
ISO	F10/F12
A	433
B	27
C x depth	M10x15
D x depth	M12x18
E	102
F	125
G	19,5
H	61,5
I	22
L	178
M	78,5

N	99,5
O	29,5
P	69,5
Q	78,5
R	31,8
S	30
T	148
W (Gas)	1/4"
Ch	27
Weight (Kg)	12
Air (dm3/cycle)	3,5

H = CENTER OF PLATE'S FIXING

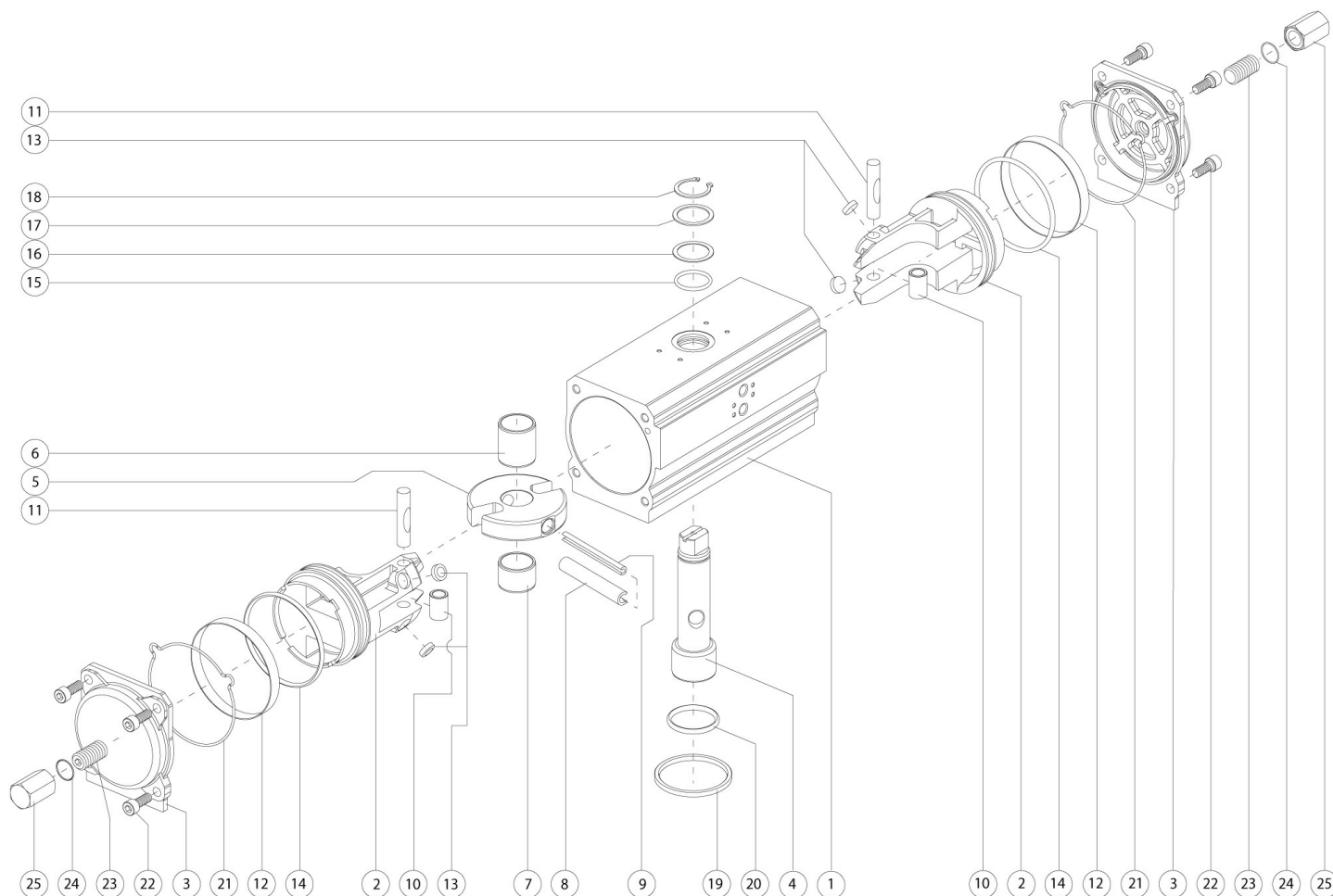

**MATERIALS SPECIFICATION**

Pos	Denomination	Q.ty	Material
1	Cylinder	1	Aluminium alloy
2	Pyston	2	Aluminium alloy
3	Cap DA	2	Aluminium alloy
4	Shaft	1	Stainless steel
5	Scotch yoke	1	Steel alloy
6	Bush	1	Acetalic resins
7	Bush	1	Acetalic resins

8	Ext. elastic pin	1	Steel alloy
9	Int. elastic pin	1	Steel alloy
10	Bush	2	Steel alloy
11	Sleeve	2	Steel alloy
12**	Dynamic seal	2	Polyurethan
13**	Support disk	4	Carbo-graphite filled PTFE
14**	O-ring	2	NBR
15**	O-ring	1	Viton
16**	Ext.support ring	1	Acetalic resins
17	Washer	1	Stainless steel
18	Seeger	1	AISI 420
19	Center ring F12	1	Aluminium alloy
20**	O-ring	1	Viton
21**	O-ring	2	NBR
22	Screws	8	Stainless steel
23*	Grub screws	2	Steel alloy
24*	O-ring	2	NBR
25*	Adjusting nut	2	Aluminium alloy
* Actuator with regulation Code: DA___411			

\*\*Components of spare part kit

# Codes, dimensions and materials - DAN960

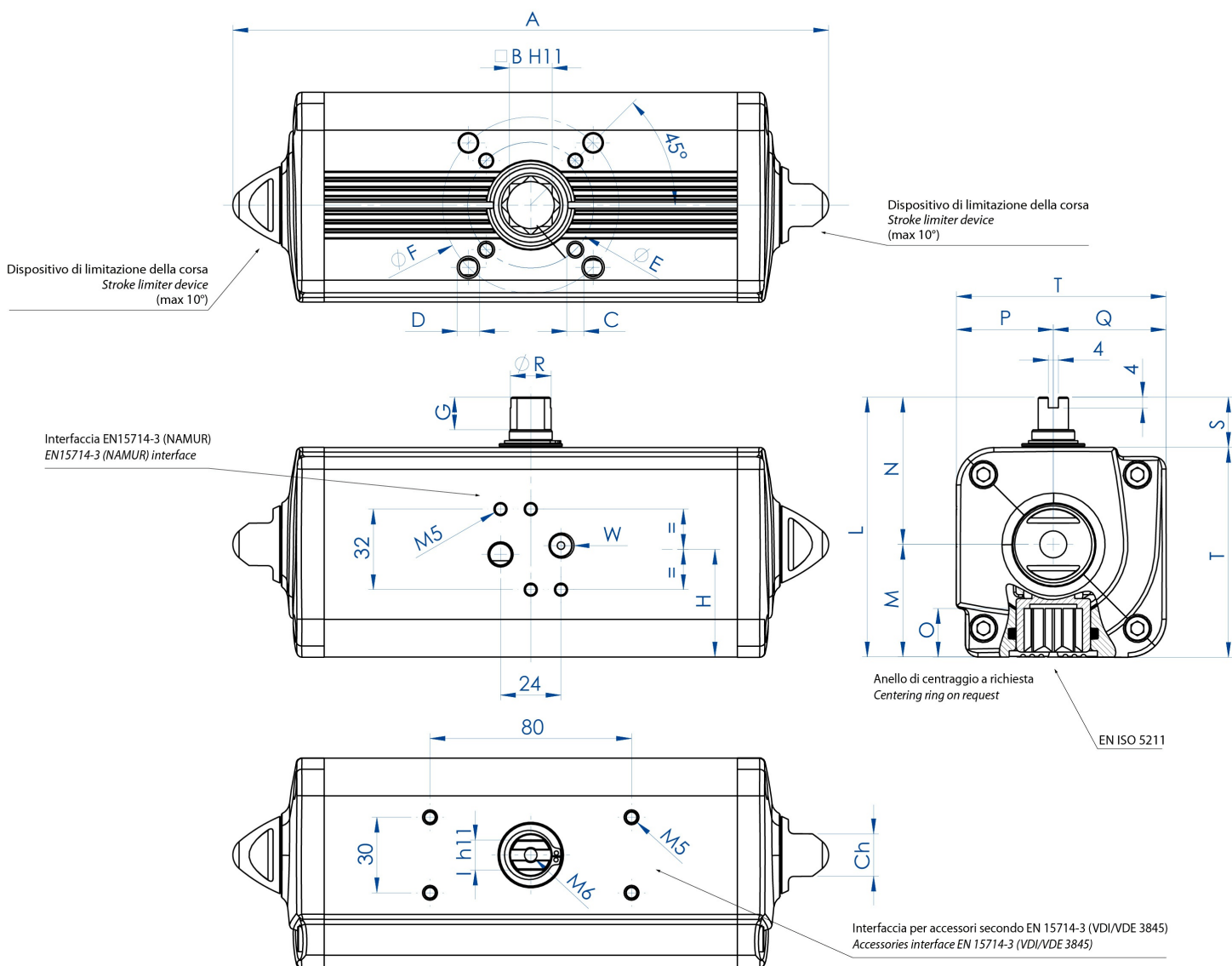

## DATA TABLE

Code	DAN0960411S	DAN0960412S
Spare seals	KGGI0024	
<b>Size</b>	<b>DAN960</b>	
ISO	F10/F12	F14
A	479,4	479,4
B	36	36
C x depth	M10x15	M16x24
D x depth	M12x18	-
E	102	140
F	125	-
G	19,5	19,5
H	78	78
I	24	24
L	198	198
M	93,5	93,5

N	104,5	104,5
O	38,8	38,5
P	74,5	74,5
Q	93,5	93,5
R	36,5	36,5
S	30	30
T	168	168
W (Gas)	1/4"	1/4"
Ch	27	27
Weight (Kg)	17,4	17,4
Air (dm3/cycle)	4,9	4,9

H = CENTER OF PLATE'S FIXING

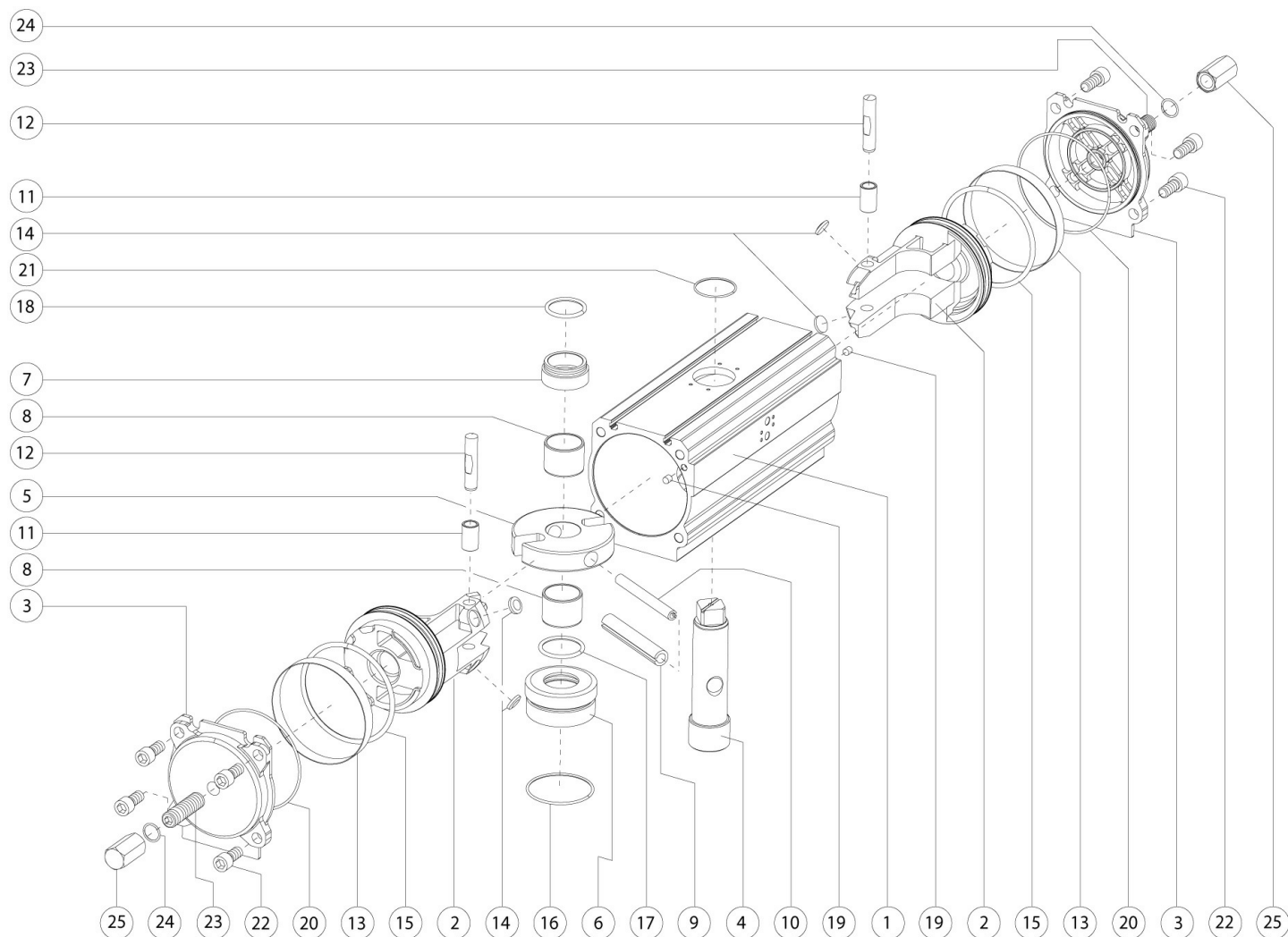

### MATERIALS SPECIFICATION

Pos	Denomination	Q.TA' Q.ty	Material
1	Cylinder	1	Aluminium alloy
2	Pyston	2	Aluminium alloy
3	Cap DA	2	Aluminium alloy
4	Shaft	1	Stainless steel
5	Scotch yoke	1	Stainless steel

6	Bush	1	Aluminium alloy
7	Bush	1	Aluminium alloy
8	Bush	2	Acetalic resins
9	Ext. elastic pin	1	Stainless steel
10	Int. elastic pin	1	Stainless steel
11	Bush	2	Stainless steel
12	Sleeve	2	Stainless steel
13**	Dynamic seal	2	Polyurethan
14**	Support disk	4	Carbo-graphite filled PTFE
15**	O-ring	2	NBR
16	O-ring	1	NBR
17**	O-ring	1	Viton
18**	O-ring	1	Viton
19	Plug	2	NBR
20**	O-ring	2	NBR
21	O-ring	1	NBR
22	screws	8	Stainless steel
23*	Grub screws	2	Stainless steel
24*	O-ring	2	Gomma nitrilica NBR
25*	Adjusting nut	2	Aluminium alloy

\* Actuator with regulation Code: DA\_\_\_411

\*\*Components of spare part kit

# Codes, dimensions and materials - DAN1440 - DAN1920

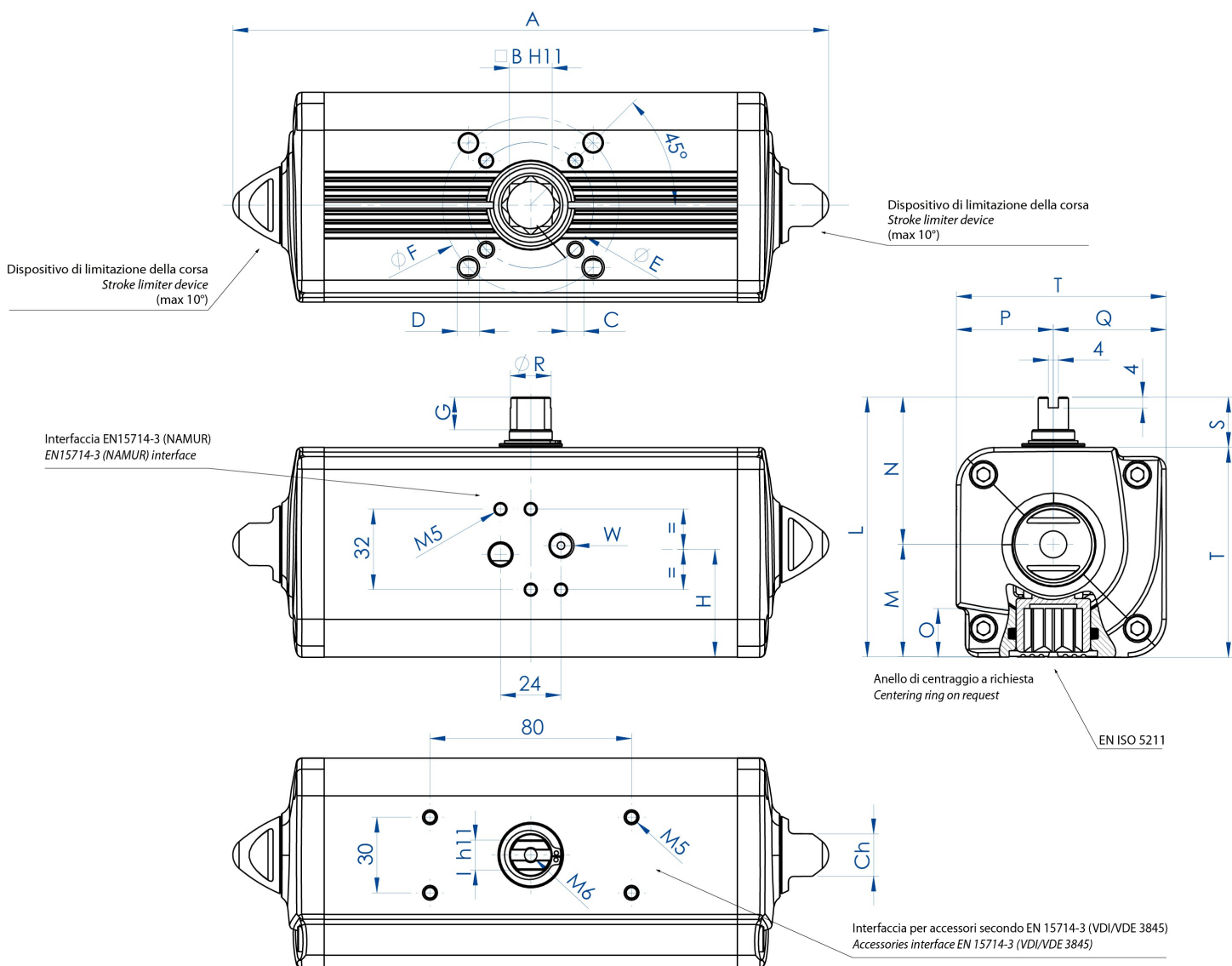

## DATA TABLE

Code	DAN1440412S	DAN1440411S	DAN1920412S	DAN1920411S
Spare seals	KGGI0025		KGGI0026	
<b>Size</b>	<b>DAN1440</b>		<b>DAN1920</b>	
ISO	F12	F14	F12/F16	F14
A	567	567	601	601
B	36	36	46	46
C x depth	M12x18	M16x24	M12x18	M16x24
D x depth	-	-	M20X30	-
E	125	140	125	140
F	-	-	165	-
G	19,5	19,5	18,5	18,5
H	86,5	86,5	99,2	99,2
I	27	27	32	32
L	216	216	237,7	237,7
M	101,5	101,5	114,7	114,7



N	114,5	114,5	123	123
O	38,5	38,5	48,5	48,5
P	84,5	84,5	93	93
Q	101,5	101,5	114,7	114,7
R	41	41	46	46
S	30	30	30	30
T	186	186	207,7	207,7
W (Gas)	1/4"	1/4"	1/4"	1/4"
Ch	36	36	36	36
Weight (Kg)	23,4	23,4	32	32
Air (dm3/cycle)	7,6	7,6	10,2	10,2

H = CENTER OF PLATE'S FIXING

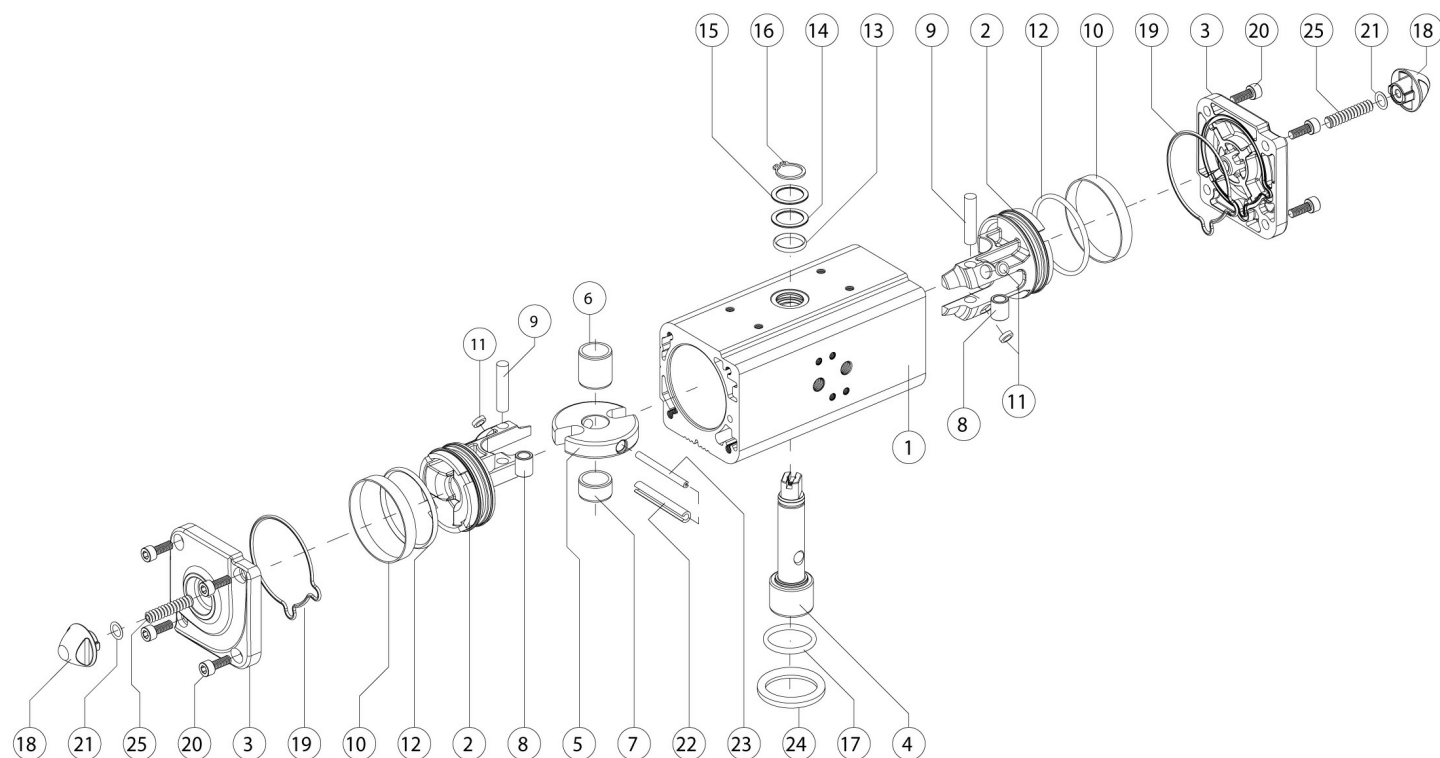

**MATERIALS SPECIFICATION**

Pos	Denomination	Q.ty	Material
1	Cylinder	1	Aluminium alloy
2	Piston	2	Aluminium alloy
3	Cap	2	Aluminium alloy
4	Shaft	1	Stainless steel
5	Scotch yoke	1	Steel alloy
6	Support bush	1	Acetalic resin
7	Shaft support	1	Acetalic resin
8	Bush	2	Steel alloy
9	Rotative sleeve	2	Steel alloy
10*	Dynamic seal	2	Polyurethan
11*	Piston's suport	4	PTFE caric carbo-grafite

12*	O-ring	2	Nitrilic rubber
13*	O-ring (upper sealing shaft)	1	FKM
14*	External support ring	1	Acetatic resins
15	Washer	1	Stainless steel
16	Seeger	1	Stainless steel
17*	O-ring (low sealing shaft)	1	FKM
18	Nut	2	Aluminium alloy
19*	Tappo o-ring	2	Nitrilic rubber
20	Screws	8	Stainless steel
21	O-ring	2	Nitrilic rubber
22	External elastic pin of the yoke	1	Steel alloy
23	Internal elastic pin of the yoke	1	Steel alloy
24	Centering ring	1	Aluminium alloy
25	Stroke adjustment screw	2	Stainless steel

\*Components of spare part kit

# Codes, dimensions and materials - DA2880

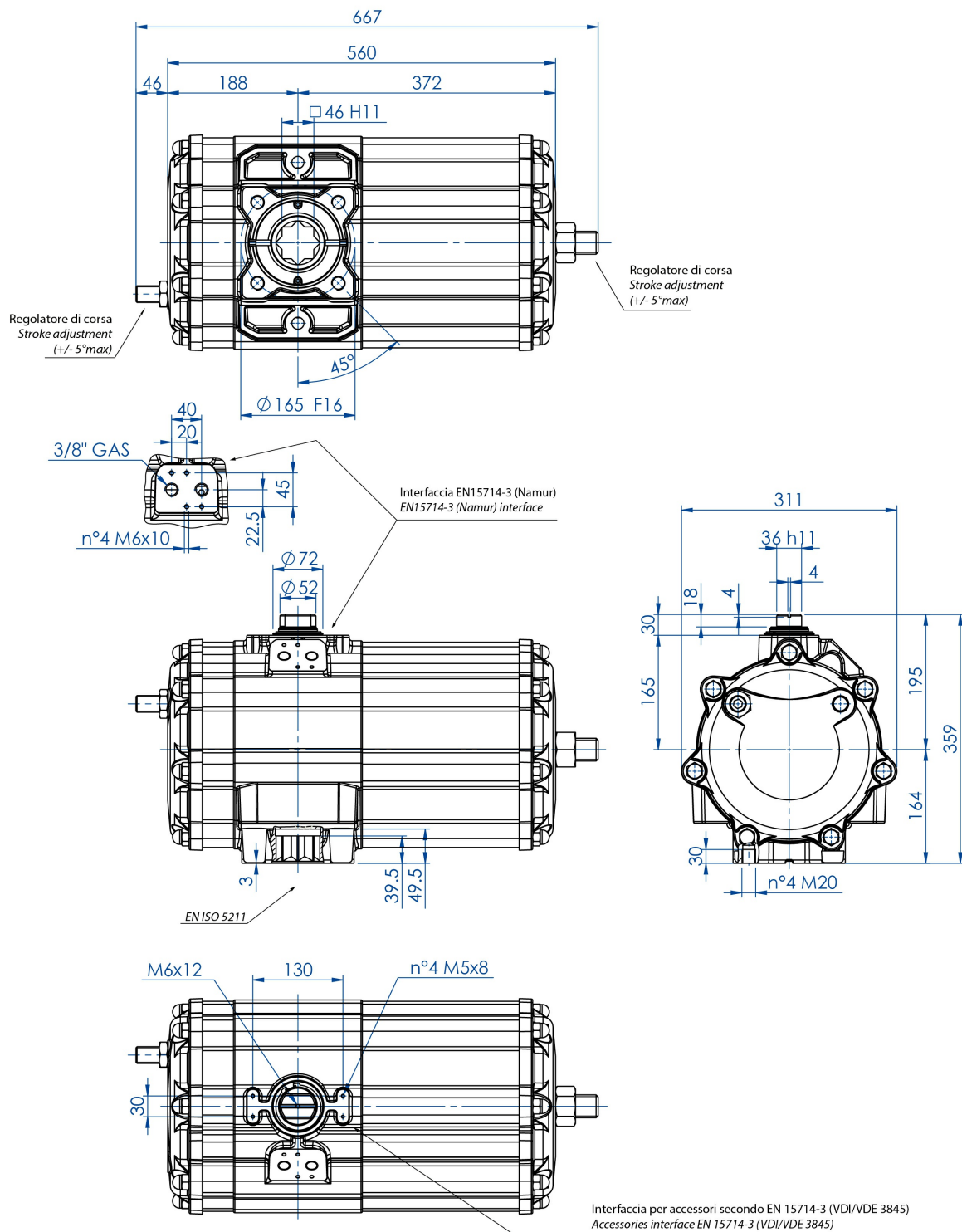

## DATA TABLE

Code	DA2880E16D0A
Weight (Kg)	55,4
Air volume (dm <sup>3</sup> /cycle)	20,0
Spare seals	KGDI1035

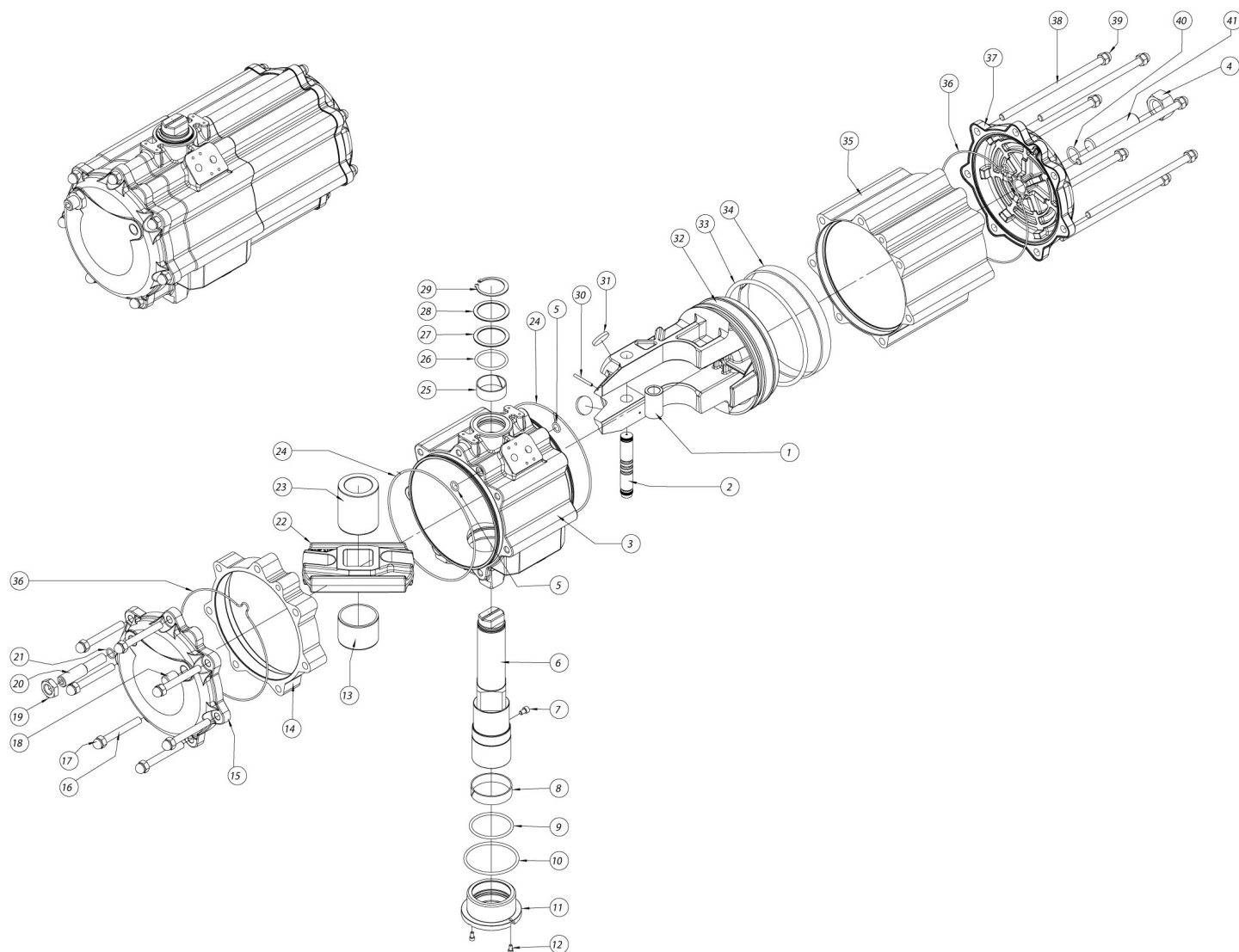

## MATERIALS SPECIFICATION

Pos	Denomination	Q.ty	Material
1	Steel bush	1	Steel alloy
2	Steel pin	1	Steel alloy
3	Body	1	Aluminium
4	Nut	1	Steel alloy
5*	O-ring	2	NBR
6	Shaft	1	Steel alloy
7	Screw	1	Steel alloy
8*	Bearing (shaft bottom)	1	Acetalic resins
9*	O-ring	1	FKM
10*	O-ring	1	FKM
11	Low bearing bush	1	Aluminium
12	Screw	2	Steel alloy
13	Bearing shaft	1	Acetalic resins
14	Spacer	1	Aluminium
15	Cap	1	Aluminium
16	Cap screw	7	Steel alloy

17	Cap nut	7	Steel alloy
18	Grub screw	1	Steel alloy
19	Nut	1	Steel alloy
20	Grub screw	1	Steel alloy
21*	O-ring	1	NBR
22	Scotch yoke	1	Steel alloy
23	Bearing shaft	1	Acetalic resin
24*	O-ring	2	NBR
25*	Bearing (shaft top)	1	Acetalic resin
26*	O-ring	1	FKM
27*	Trusth bearing	1	Acetalic resin
28	Washer	1	Steel alloy
29	Seeger	1	Steel alloy
30	Spring pin	1	Steel alloy
31*	Bearing (piston back)	2	Acetalic resin
32	Piston	1	Aluminium
33*	O-ring	1	NBR
34*	Bearing (piston head)	1	Acetalic resin
35	Lateral cylinder	1	Aluminium
36*	O-ring	2	NBR
37	Cap	1	Aluminium
38	Cap screw	7	Steel alloy
39	Cap nut	7	Steel alloy
40*	O-ring	1	NBR
41	Grub screw	1	Steel alloy

\*Components of spare part kit

# Codes, dimensions and materials - DA3840

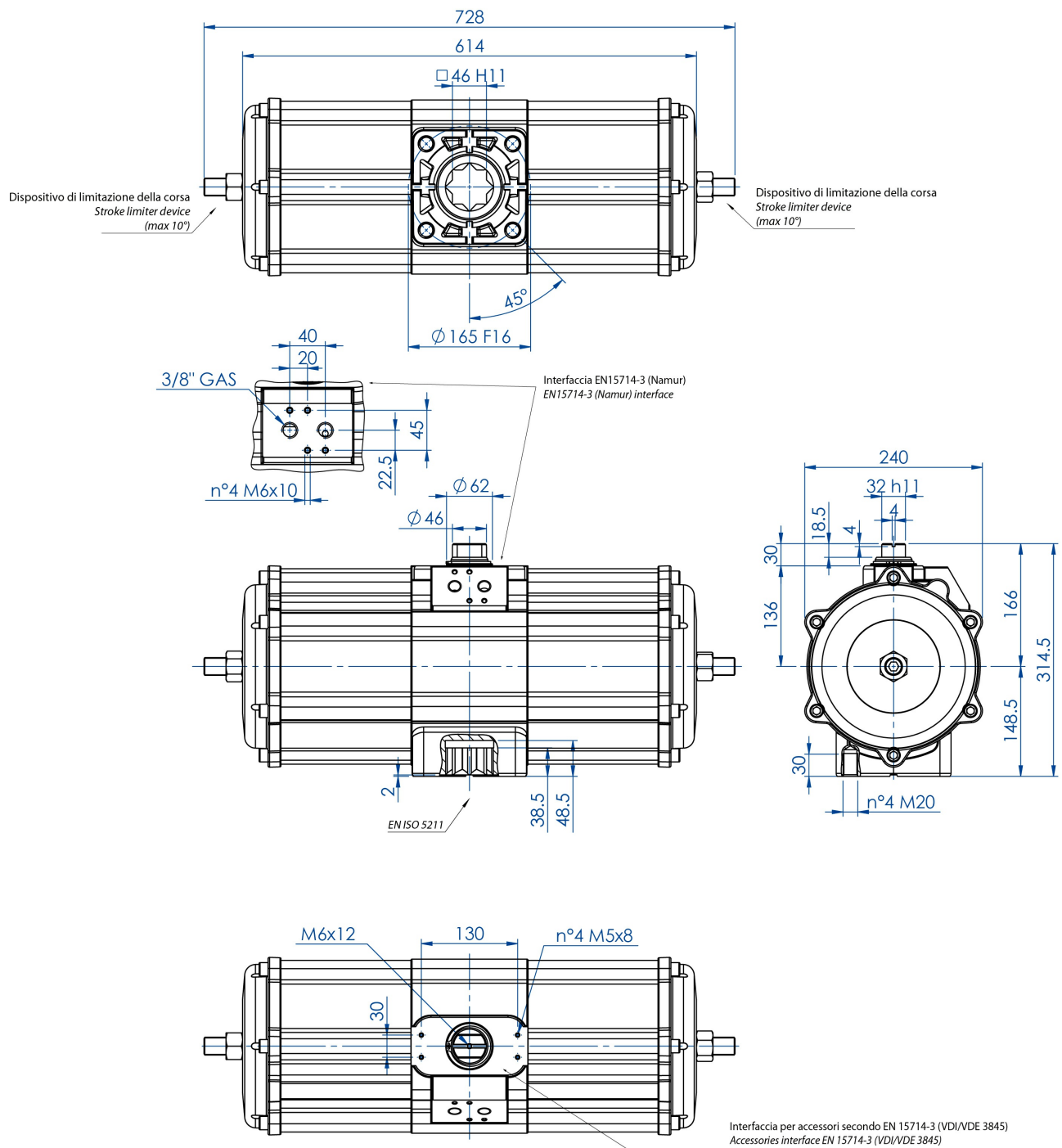

## DIMENSION TABLE

Code	DA3840E1600A
Weight (kg)	49,0
Air volume (dm <sup>3</sup> /cycle)	25,6
Spare seals	KGDI0030

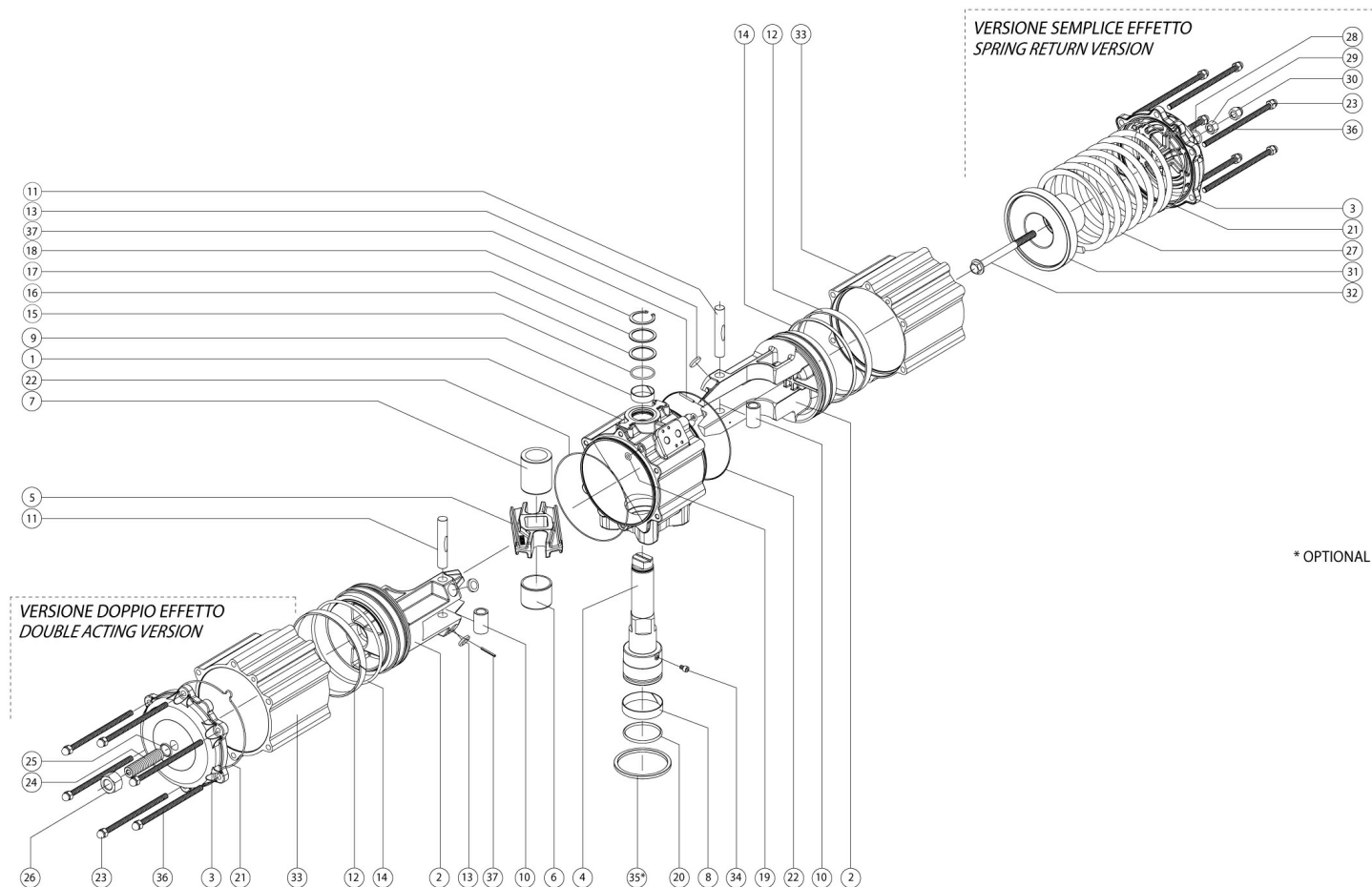

### MATERIALS SPECIFICATION

Pos	Denomination	Q.ty	Material
1	Cylinder	1	Aluminium alloy
2	Piston	2	Aluminium alloy
3	Cap	2	Aluminium alloy
4	Shaft	1	Stainless steel
5	Scotch yoke	1	Steel alloy
6	Bearing shaft	1	Acetalic resins
7	Bearing shaft	1	Acetalic resins
8*	Bearing (shaft bottom)	1	Acetalic resins
9*	Bearing (shaft top)	1	Acetalic resins
10	Steel bush	2	Steel alloy
11	Steel pin	2	Lega acciaio
12*	Bearing (piston head)	2	Acetalic resins
13*	Bearing (piston back)	4	Acetalic resins
14*	O-ring	2	NBR
15*	O-ring	1	FKM
16*	Thrust bearing	1	Acetalic resins
17	Washer	1	Stainless steel
18	Seeger	1	Stainless steel
19*	O-ring	2	NBR
20*	O-ring	1	FKM

21*	O-ring	2	NBR
22*	O-ring	2	NBR
23	Cap nut	12	Stainless steel
24	Grub screws	2	Stainless steel
25*	O-ring	2	NBR
26	Nut	2	Stainless steel
27	Spring	4	Steel alloy
28*	O-ring	2	NBR
29	Nut	2	Stainless steel
30	Cap nut	2	Stainless steel
31	Spring cap	2	Aluminium alloy
32	Screw	2	Stainless steel
33	Cylinder	2	Aluminium alloy
34	Screw	1	Stainless steel
35	Center ring	1	Aluminium alloy
36	Cap screw	12	Steel alloy
37	Spring pin	2	Steel alloy

\*Components of spare part kit





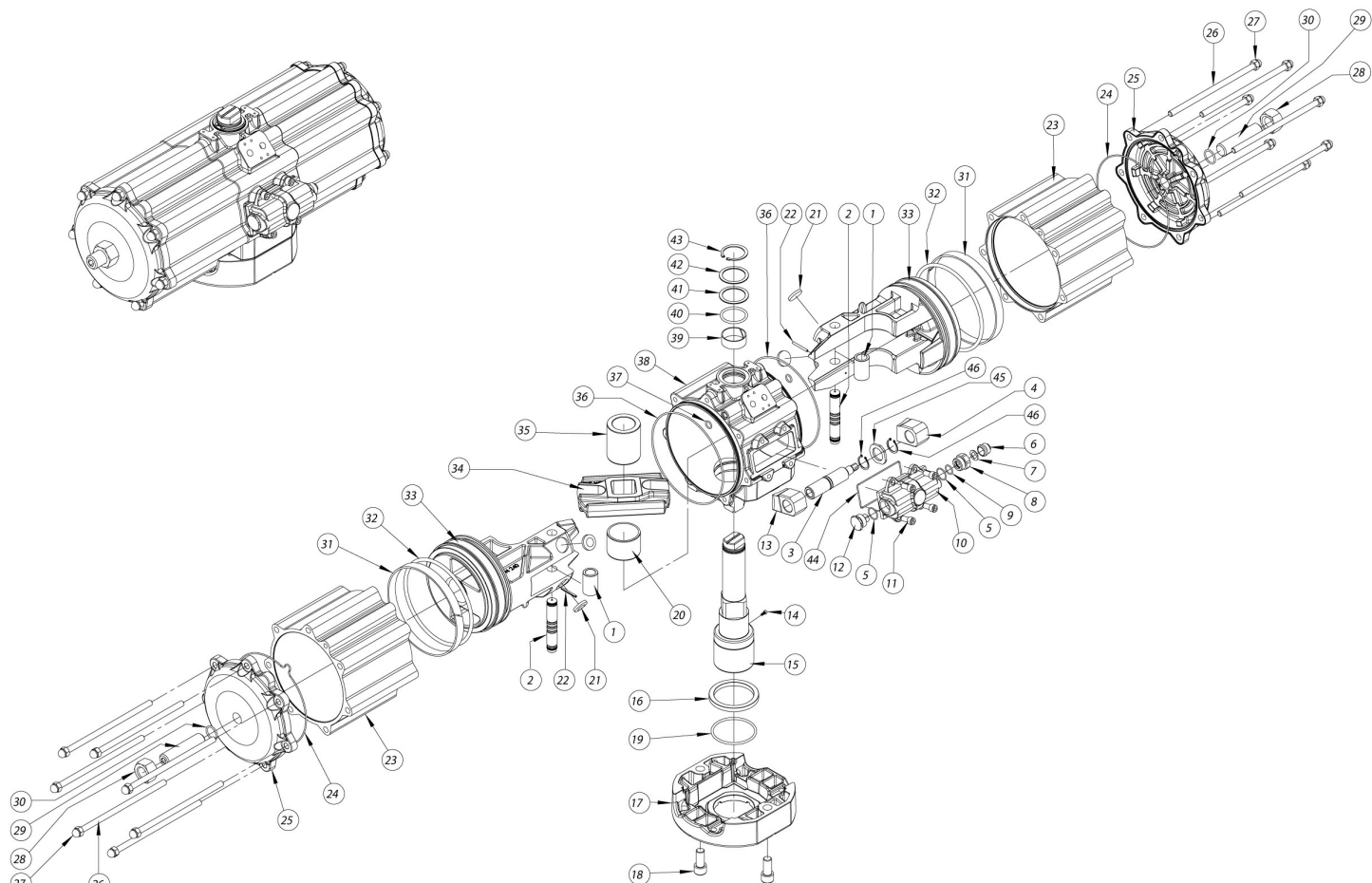

### MATERIALS SPECIFICATION

Pos	Denomination	Q.TA'	Material
1	Steel bush	2	Steel alloy
2	Steel pin	2	Steel alloy
3	Regolation screw	1	Steel alloy
4	Left stop	1	Steel alloy
5*	O-ring	2	NBR
6	Pretection cap	1	Aluminium
7	Antirotaion washer	1	Steel alloy
8	Metal ring	1	Stainless steel
9*	O-ring	1	NBR
10	Carter	1	Aluminium
11	Screw	4	Steel alloy
12	Metal ring	1	Stainless steel
13	Right stop	1	Steel alloy
14	Screw	1	Steel alloy
15	Shaft	1	Steel alloy
16	Bearing (shaft bottom)	1	Acetalic resins
17	Interface F25	1	Aluminium
18	Screw	2	Steel alloy
19*	O-ring	1	FKM

20	Bearing shaft	1	Acetalic resins
21*	Bearing (piston back)	4	Acetalic resins
22	Spring pin	2	Steel alloy
23	Lateral cylinder	2	Aluminium
24*	O-ring	2	NBR
25	Cap	2	Aluminium
26	Cap screws	14	Steel alloy
27	Cap nut	14	Steel alloy
28	Nut	2	Steel alloy
29	Grub screws	2	Steel alloy
30*	O-ring	2	NBR
31*	Bearing (piston head)	2	Acetalic resin
32*	O-ring	2	NBR
33	Piston	2	Aluminium
34	Scotch yoke	1	Steel alloy
35	Bearing shaft	1	Acetalic resin
36*	O-ring	2	NBR
37*	O-ring	2	NBR
38	Body	1	Aluminium
39*	Bearing (shaft top)	1	Acetalic resin
40*	O-ring	1	FKM
41*	Thrust bearing	1	acetalic resin
42	Washer	1	Steel alloy
43	Seeger	1	Steel alloy
44*	Gasket	1	NBR
45	Washer	1	Steel alloy
46	Seeger	2	Steel alloy

\*Components of spare part kit

# Codes, dimensions and materials - DA8000

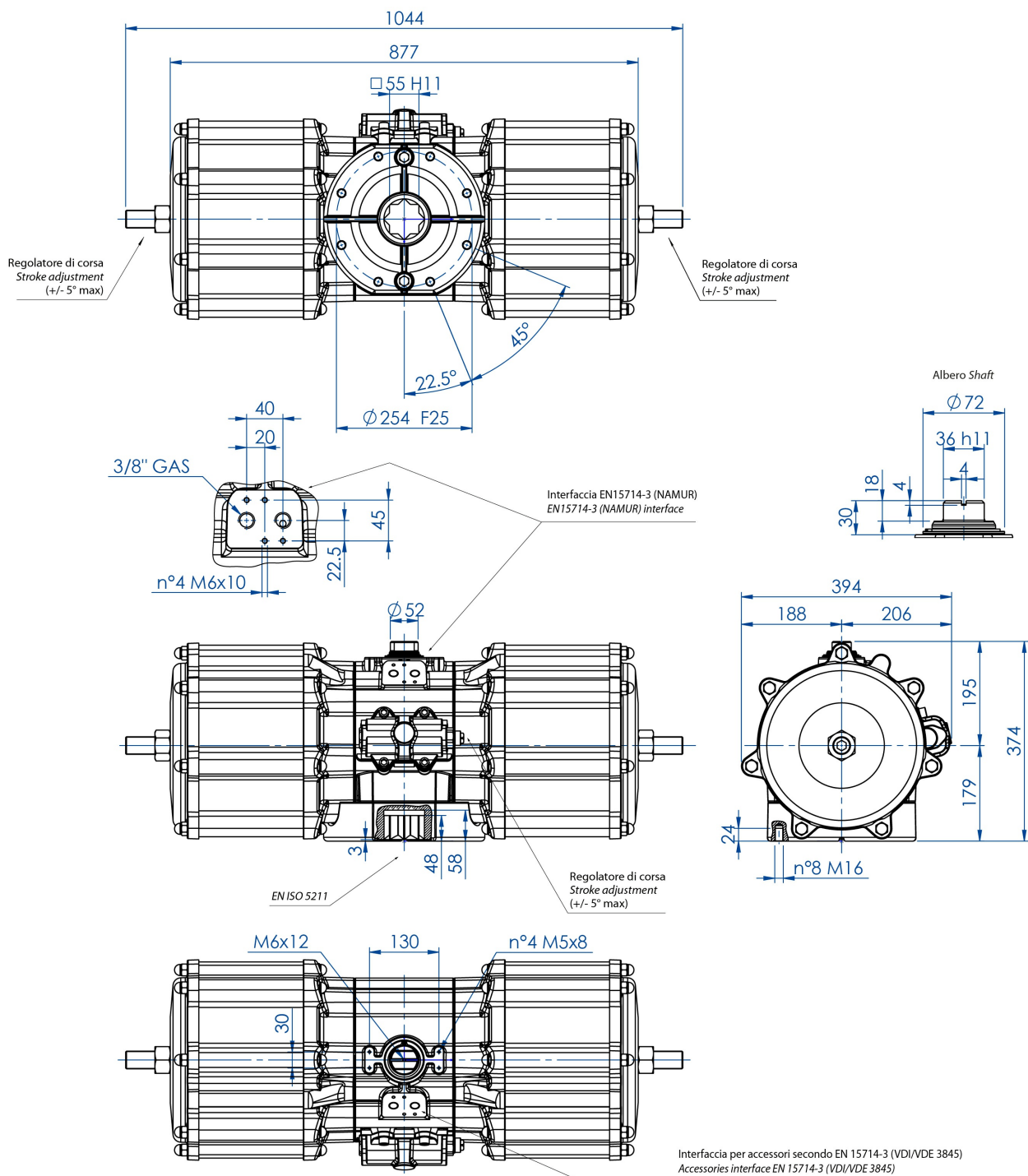

## DATA TABLE

Code	DA8000E25D0A
Weight (Kg)	105,5
Air volume (dm <sup>3</sup> /cycle)	50,0
Spare seals	KGDI1040

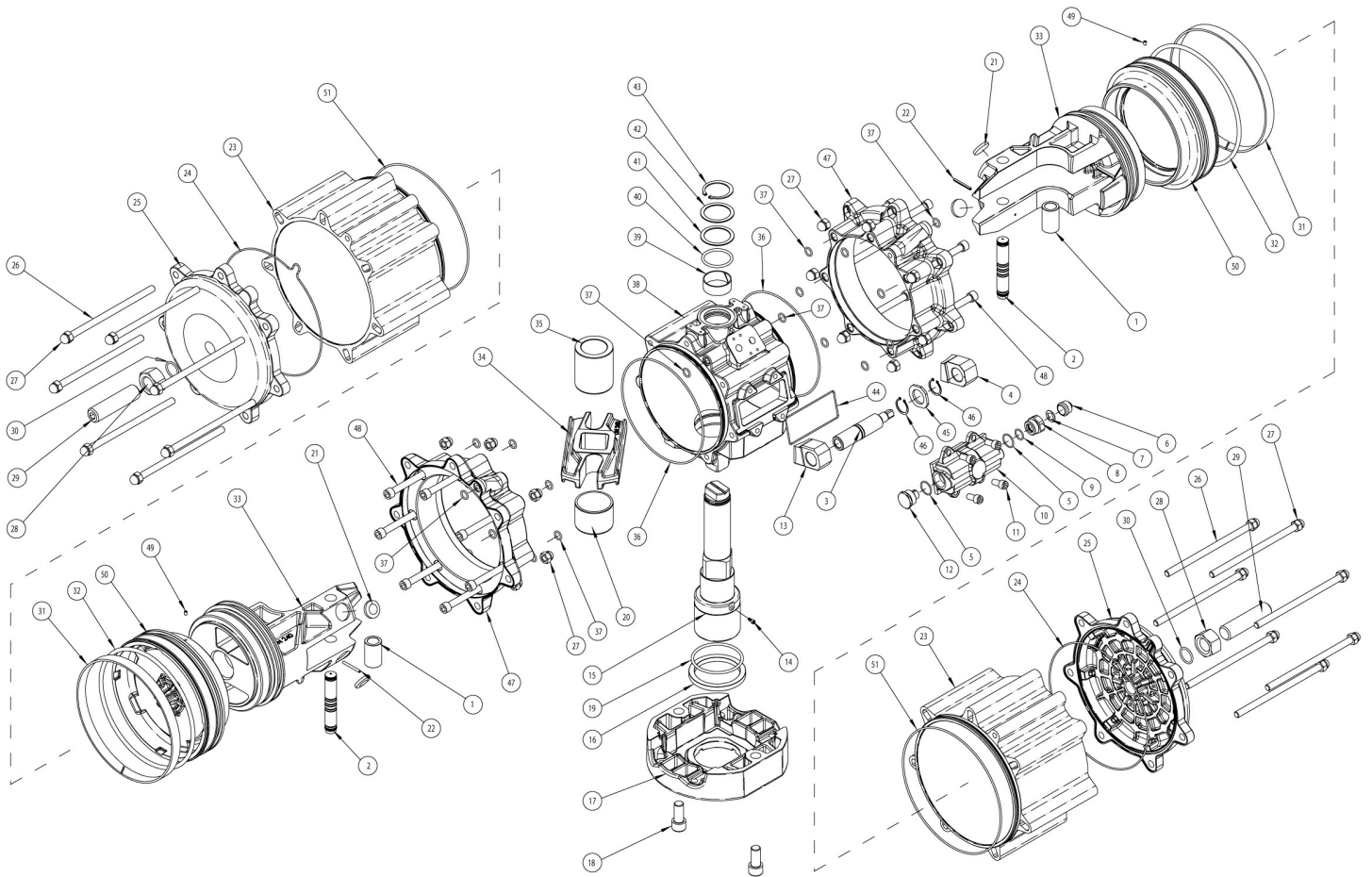

## MATERIALS SPECIFICATION

Pos	Denomination	Q.TA'	Material
1	Steel bush	2	Steel alloy
2	Steel pin	2	Steel alloy
3	Regulation screw	1	Steel alloy
4	Left stop	1	Steel alloy
5*	O-ring	2	NBR
6	Protection cap	1	Aluminium
7	Antirotation washer	1	Steel alloy
8	Metal ring	1	Stainless steel
9*	O-ring	1	NBR
10	Carter	1	Aluminium
11	Screw	4	Steel alloy
12	Metal ring	1	Stainless steel
13	Right stop	1	Steel alloy
14	Screw	1	Steel alloy
15	Shaft	1	Steel alloy
16	Bearing (shaft bottom)	1	Acetalic resins
17	Interface F25	1	Aluminium
18	Screw	2	Steel alloy
19*	O-ring	1	FKM
20	Bearing shaft	1	Acetalic resins

21	Bearing (piston back)	4	Acetalic resins
22	Spring pin	2	Acciaio Steel alloy
23	Lateral cylinder	2	Aluminium
24*	O-ring	2	NBR
25	Cap	2	Aluminium
26	Cap screws	14	Steel alloy
27	Cap nut	28	Steel alloy
28	Nut	2	Steel alloy
29	Grub screws	2	Steel alloy
30*	O-ring	2	NBR
31*	Bearing (piston head)	2	Acetalic resins
32*	O-ring	2	NBR
33	Piston	2	Aluminium
34	Scotch yoke	1	Steel alloy
35	Bearing shaft	1	Acetalic resins
36*	O-ring	2	NBR
37*	O-ring	18	NBR
38	Body	1	Aluminium
39*	Bearing (shaft top)	1	Acetalic resins
40*	O-ring	1	FKM
41*	Thrust bearing	1	Resina acetlica
42	Washer	1	Steel alloy
43	Seeger	1	Steel alloy
44*	Gasket	1	NBR
45	Washer	1	Steel alloy
46	Seeger	2	Steel alloy
47	Flange	2	Aluminium
48	Screws	14	Steel alloy
49	Grub screw	2	Steel alloy
50	Flange	2	Aluminium
51*	O-ring	2	NBR

\*Components of spare part kit