

MERCEDES-BENZ
SPRINTER



UPFIT
GUIDE

RANGER
DESIGN

Helping Mobile Technicians Work More Effectively by Providing Organized Storage Solutions

At Ranger Design, we believe more is possible.

We believe work vehicles and the technicians that drive them can become more organized, more efficient, more productive and more profitable. At Ranger Design we're committed to bringing you the products and services that make that possible.

More means helping you choose the right work van for your

application, as well as giving you engineering support and expert advice to help design the most efficient work space in your new vehicle.

More also means getting that new van outfitted and on the road faster, so you can start using it for the reason you bought it.

We're committed to bringing you more, because we believe more is possible.



MORE IS POSSIBLE



TABLE OF CONTENTS

CHOOSE YOUR PRODUCT LINE	P. 4
PLAN YOUR VAN OUTFIT	P. 6
GETTING STARTED	P. 8
PARTITIONS	P. 10
PACKAGES	P. 16
SHELVING	P. 34
DRAWERS	P. 46
ACCESSORIES	P. 51
LADDER RACKS	P. 55
HOW TO BUY	P. 60
INDEX	P. 62

Choose A Product Line To Match Your Needs

Ranger Fleetline and Proline product groups ensure that fleets of any size have the best equipment to fit their budget, trade or fuel saving targets.



Ranger Fleetline shown



Ranger Proline shown

	MATERIAL	BENEFITS	PRODUCTS	WARRANTY
<p>WHY BUY RANGER FLEETLINE? You want better quality and price than other steel products on the market.</p>	Steel	Tough Low cost Quiet	Shelving, Partitions, Drawers, Accessories	3 years*
<p>WHY BUY RANGER PROLINE? You want the toughest, quietest product on the market. You need to optimize payload without sacrificing quality.</p>	Aluminum	Toughest Lightweight Quiet	Shelving, Partitions, Drawers, Accessories, Ladder Racks	10 years*

*Ranger Design Inc. van equipment is warranted to be free from defects in material and workmanship under normal use and service for the period indicated, from the date of the original retail purchase, when installed per Ranger Design instructions in the original vehicle. Please contact Customer Service for full warranty details. Email: cs@rangerdesign.com

Throughout the catalog **FLEETLINE** products are depicted with yellow and **PROLINE** products with black.

1-800-565-5321
7 A.M. – 8 P.M. EST

World Class Customer Service



Real people, ready to answer in 2 rings or less*

We are pleased to offer efficient, personalized service and to answer all questions regarding:

- › Pricing/Quoting
- › Product install
- › Order status
- › Consultation
- › Shipment status
- › New product availability
- › Product specifications
- › Warranty claims
- › Returns/Restocking
- › Vehicle specifications

*Call customer service and the phone will be answered in 2 rings or less. Yes, a real, live person working in one of our offices in North America is available to answer your questions. No automated attendant. No complicated phone tree and offshore service. Call us to experience the difference.

PLAN YOUR VAN OUTFIT

INSIDE ROOF HEIGHT

To determine the maximum shelf height that can be used in the van.

PARTITION DEPTH

This indicates the space taken up by our partition for this vehicle. Please note that this measurement is determined by the partition that encroaches the most. Some partitions may take up less space. Take note that this measurement may not necessarily be on the floor.

DOOR OPENING

To determine where shelving will land in relation to the door opening. Use this measurement to determine the space available for drawer units.

DIMENSIONS IN RED

These dimensions indicate unique measurements for each wheelbase. Use red dimensions to determine the exact wheelbase of your van.

FLOOR SPACE

This area is usable floor space but due to curvature of the van there may not be the same available area at the roof. Please measure actual van for specific measurement at roof.

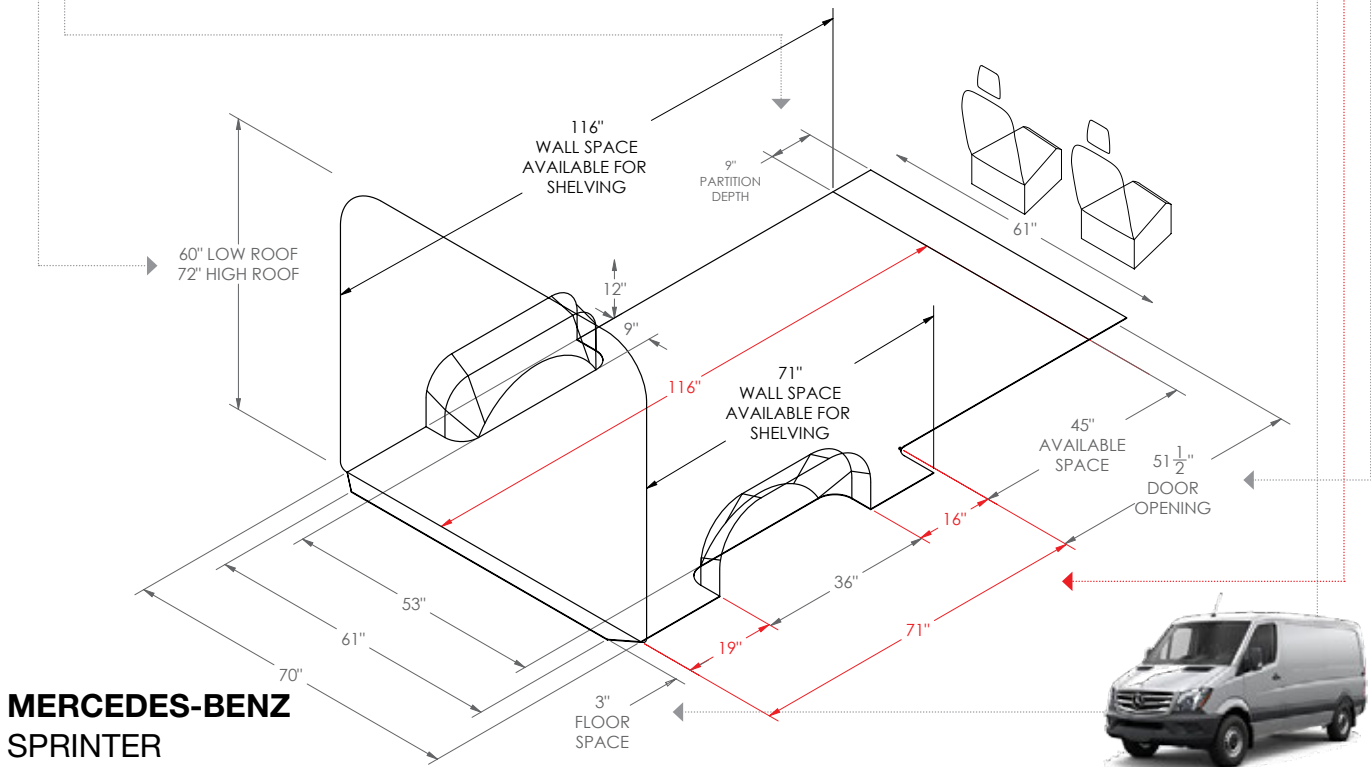

MERCEDES-BENZ SPRINTER

Regular 144" Wheelbase



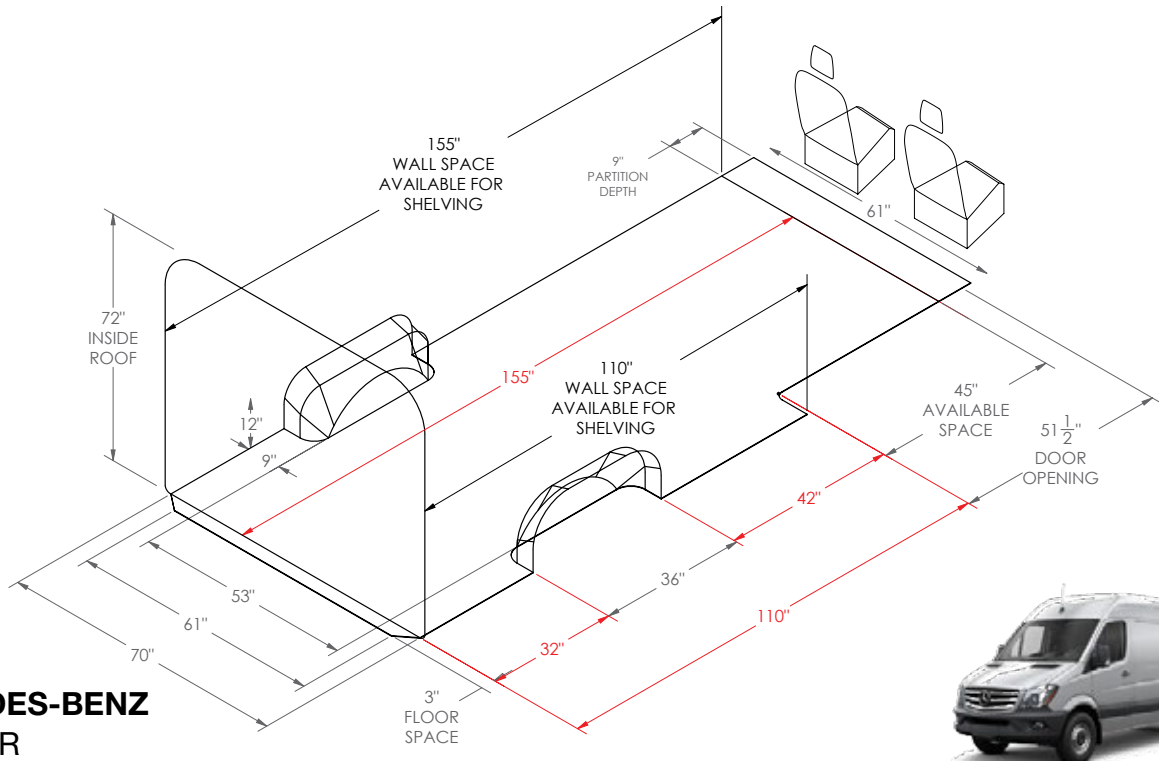

MERCEDES-BENZ SPRINTER

Long 170" Wheelbase

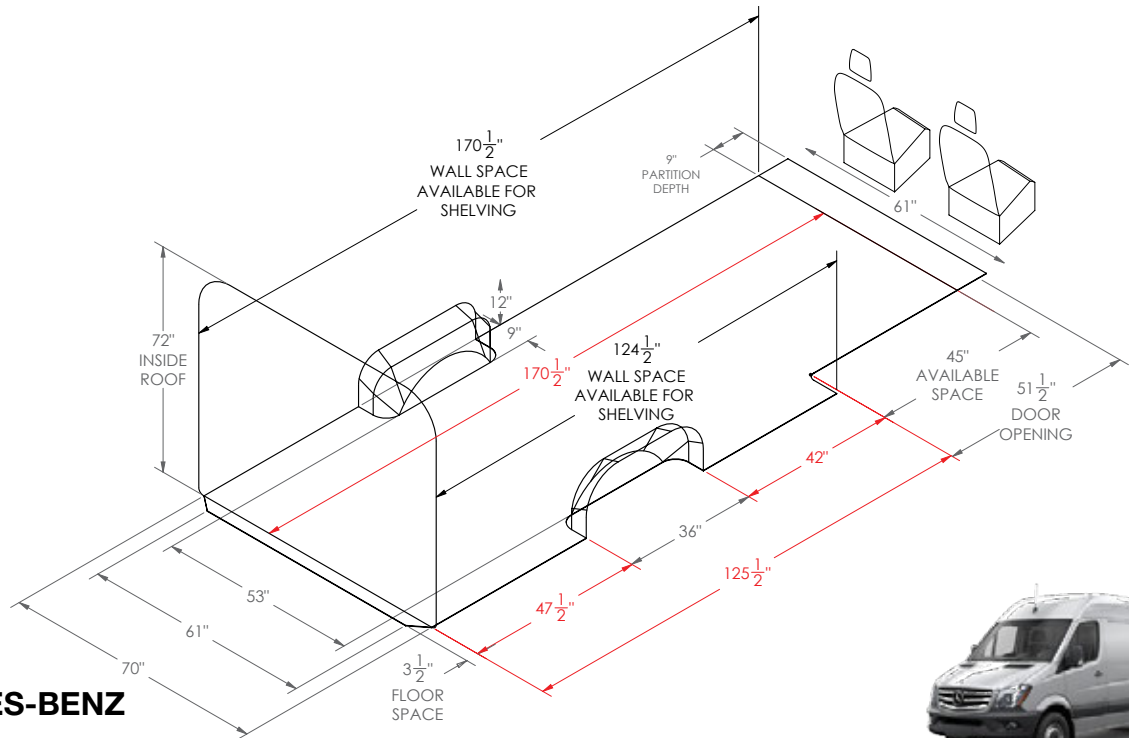

MERCEDES-BENZ SPRINTER

Extended 170" Wheelbase

Take a few minutes to write down these simple steps

Plan your storage zones

For how long do you plan to use the vehicle? A year 2–5 years 10 years or more (see page 4)

Will payload capacity be an issue? Yes No Why? _____

What type of industry are you in? _____

What kind of partition do I need?

Do I need to see my cargo or see out the side doors? Yes No

Do I need the ability to go from the cabin to the cargo area through the partition? Yes No

List the equipment/products you will need to store

Place the items that you need most often in the most accessible locations.

	How often will you use this?			Zone
	Daily	Weekly	Monthly	
_____	<input type="checkbox"/>	<input type="checkbox"/>	<input type="checkbox"/>	A-B-C-D-E
_____	<input type="checkbox"/>	<input type="checkbox"/>	<input type="checkbox"/>	_____
_____	<input type="checkbox"/>	<input type="checkbox"/>	<input type="checkbox"/>	_____
_____	<input type="checkbox"/>	<input type="checkbox"/>	<input type="checkbox"/>	_____
_____	<input type="checkbox"/>	<input type="checkbox"/>	<input type="checkbox"/>	_____

Will I need to carry larger objects Yes No Dimensions: _____

List the tools you will need to carry

Place heavy tools closest to the access doors.

	How often will you use this?			Zone
	Daily	Weekly	Monthly	
_____	<input type="checkbox"/>	<input type="checkbox"/>	<input type="checkbox"/>	A-B-C-D-E
_____	<input type="checkbox"/>	<input type="checkbox"/>	<input type="checkbox"/>	_____
_____	<input type="checkbox"/>	<input type="checkbox"/>	<input type="checkbox"/>	_____
_____	<input type="checkbox"/>	<input type="checkbox"/>	<input type="checkbox"/>	_____
_____	<input type="checkbox"/>	<input type="checkbox"/>	<input type="checkbox"/>	_____

What kind of ladder(s) will I be carrying? Step ladder Extension ladders
 Size _____ Size _____

Storage Zones

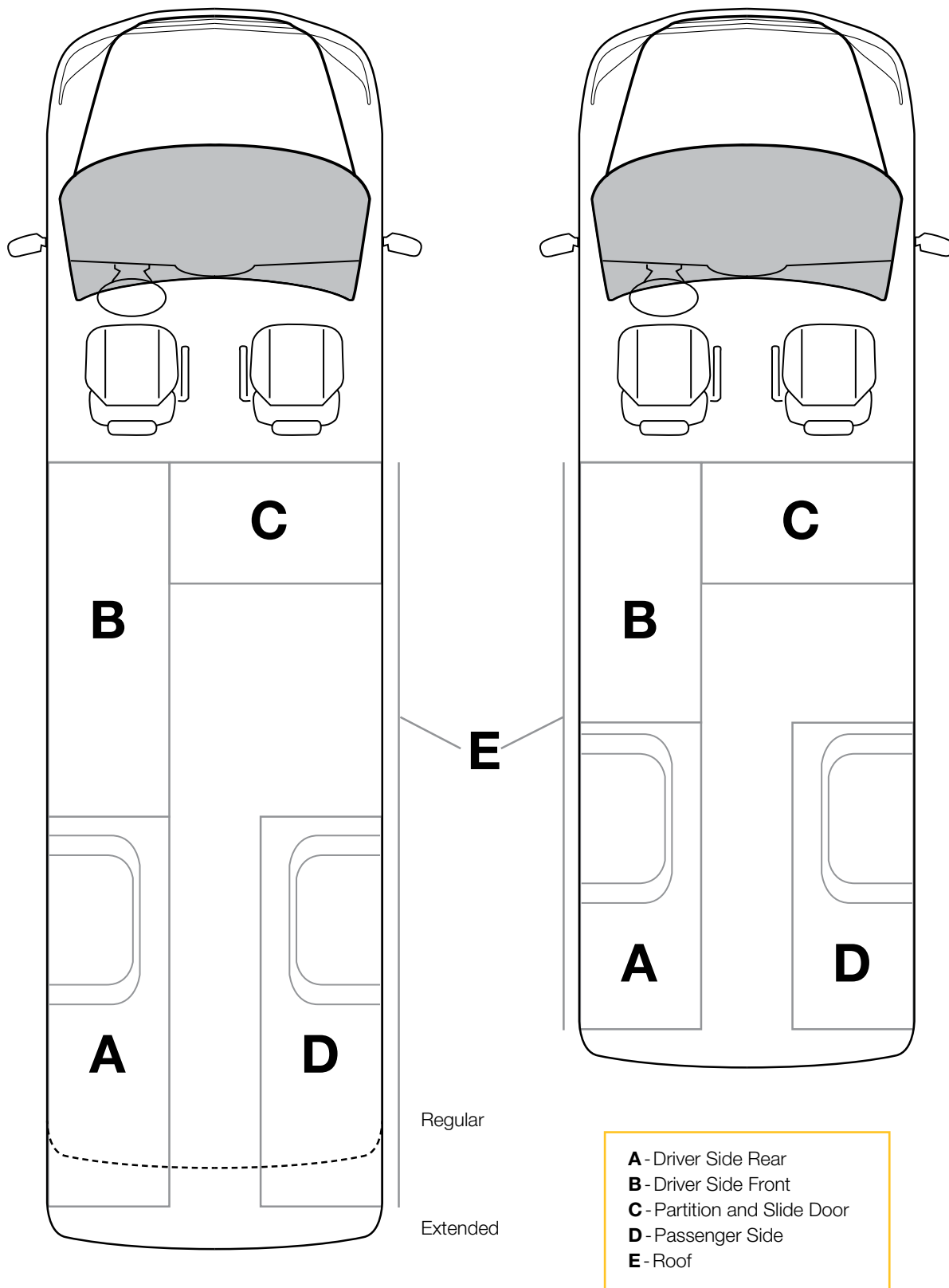



SAFETY PARTITIONS

Crash tested safety partitions protect the most important asset: you



SAFE

Designed for maximum impact resistance.
Proven by crash test.

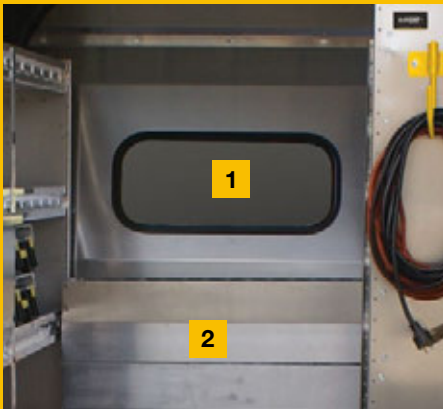

EFFICIENT

1. Contoured to maintain seat travel and ensure driver comfort. 2. Contoured to capitalize on cargo area floor space.



QUIET

Thickness of material cancels vibrations.

SAFETY PARTITIONS

STRAIGHT WALK THROUGH PARTITION P. 12

CONTOURED SAFETY PARTITION P. 13

CONTOURED SAFETY PARTITION WITH TEMPERED WINDOW P. 13

SINGLE SIDE STRAIGHT PARTITION P. 14

STRAIGHT WALK THROUGH PARTITION WITH TEMPERED GLASS WINDOW, SWING DOOR P. 14

Ranger safety partitions provide a solid and secure barrier between the occupants of the van and the cargo.

Built from heavy gauge steel and aluminum, they are designed for maximum impact resistance and uphold a standard of safety set only by Ranger products.

Ranger partitions also provide a more comfortable environment for the driver by giving more seat travel and by not rattling as the vehicle drives down the road.



SAFETY PARTITIONS

PARTITIONS



C20-DL

Straight Partition with Perforated Window, No Access

Steel	
Low Roof	
80 lbs	
1 hr	
Yes	



C20-DH

Straight Partition with Perforated Window, No Access

Steel	
High Roof	
89 lbs	
1 hr	
Yes	



C24-DL

Straight Walk Through Partition

Steel	
Low Roof	
61 lbs	
1 hr	
No	



C24-DH

Straight Walk Through Partition

Steel	
High Roof	
66 lbs	
1 hr	
No	



C30-DL

Straight Partition with Perforated Window, Swing Door

Steel	
Low Roof	
83 lbs	
1 hr	
No	



C30-DH

Straight Partition with Perforated Window, Swing Door

Steel	
High Roof	
92 lbs	
1 hr	
No	



3010-DL

Contoured Safety Partition

Aluminum	
Low Roof	
57 lbs	
1.2 hrs	
No	



3010-DH

Contoured Safety Partition

Aluminum	
High Roof	
59 lbs	
1.2 hrs	
No	



3015-DH

Mid Position Straight Safety Partition

Aluminum	
High Roof	
59 lbs	
1.2 hrs	
No	



3020-DL

Contoured Safety Partition with Tempered Glass Window

Aluminum	
Low Roof	
64 lbs	
1.2 hrs	
No	



3020-DH

Contoured Safety Partition with Tempered Glass Window

Aluminum	
High Roof	
66 lbs	
1.2 hrs	
No	



3025-DH

Mid Position Straight Safety Partition with Tempered Glass Window

Aluminum	
High Roof	
66 lbs	
1.2 hrs	
No	

SAFETY PARTITIONS



3060-DL

Single Side Straight Partition

Aluminum

Low Roof

29 lbs

0.7 hr

No



3060-DH

Single Side Straight Partition

Aluminum

High Roof

30 lbs

0.7 hr

No



3064-DL

Straight Walk Through Partition

Aluminum

Low Roof

40 lbs

1 hr

No



3064-DH

Straight Walk Through Partition

Aluminum

High Roof

42 lbs

1 hr

No



3068-DL

Straight Partition with Tempered Glass Window, Sliding Door

Aluminum

Low Roof

78 lbs

1.5 hrs

No



3068-DH

Straight Partition with Tempered Glass Window, Sliding Door

Aluminum

High Roof

80 lbs





1.5 hrs

Yes



3069-DL





Straight Partition with Tempered Glass Window, Swing Door

Aluminum	
 Low Roof	
 73 lbs	
 1.5 hrs	
 Yes	



3069-DH

Straight Partition with Tempered Glass Window, Swing Door

Aluminum	
 High Roof	
 76 lbs	
 1.5 hrs	
 Yes	



3068-DH Straight partition with tempered glass window, sliding door.



TRADE PACKAGES

Pre-engineered packages
for a broad range of trades.



CHOICE

A range of Fleetline and Proline packages are available for each vehicle.



TRADE SPECIFIC

Packages are created with the specific trades in mind. Optimized for maximum productivity.



PERFECT FIT

Engineered to optimize space. Layout designed to ensure that all tools are well within reach.

TRADE PACKAGES

CONTRACTOR P. 18

ELECTRICAL/TELECOM P. 20

HVAC P. 22

SERVICE P. 24

DELIVERY P. 30

PLUMBER P. 32

Get more out of your work van: Ranger packages are designed specifically with your trade in mind. Our aim is to ensure that your most frequently used tools and equipment are well within reach.

Do you see a way that we can improve our packages? We appreciate your feedback! Contact our customer service team at **1-800-565-5321**.



CONTRACTOR PACKAGES

PACKAGES

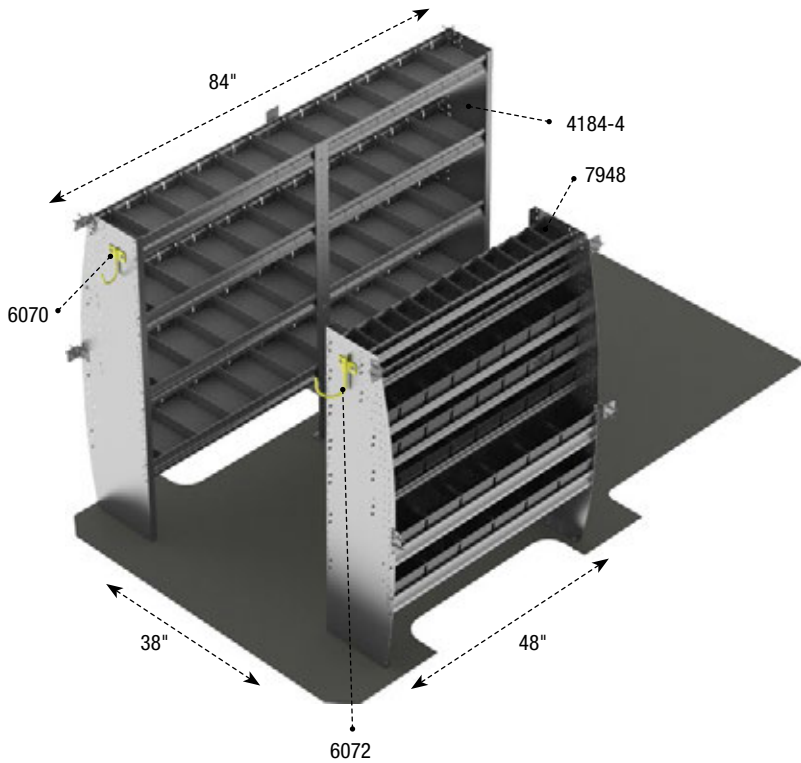

G210 Contractor Package

Aluminum

144"

Low/High Roof

212 lbs

3.2 hrs

No

Qty	Part #	Description
1	4184-4	Countoured Shelf Unit
1	6070	Fixed Hook
1	6072	Swivel Hook
1	7948	Countoured Bin Unit

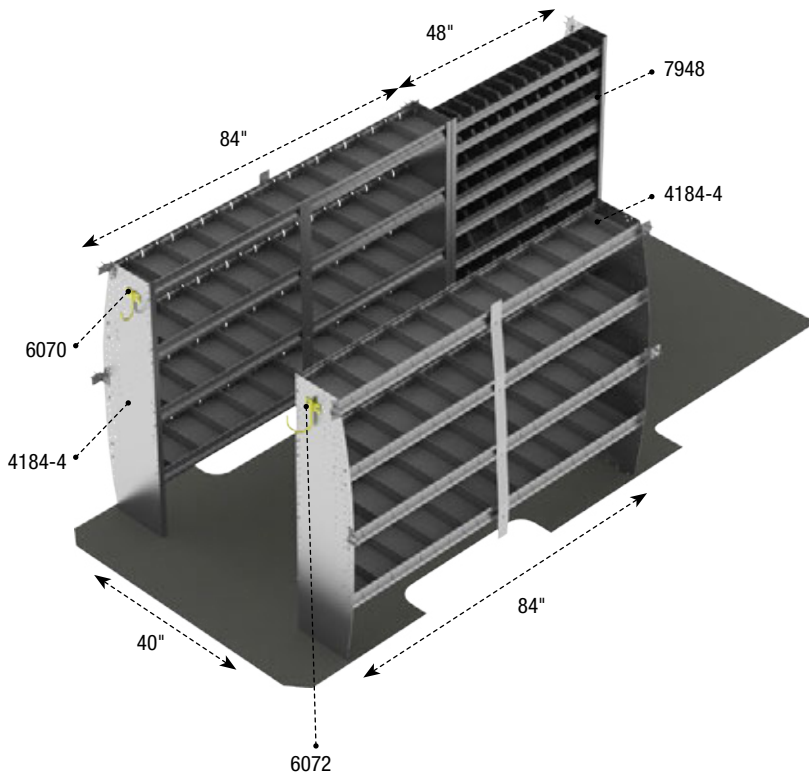

G710 Contractor Package

Aluminum

170", 170" Ext

High Roof

300 lbs

4.6 hrs

No

Qty	Part #	Description
2	4184-4	Countoured Shelf Unit
1	6070	Fixed Hook
1	6072	Swivel Hook
1	7948	Countoured Bin Unit

CONTRACTOR PACKAGES

PACKAGES

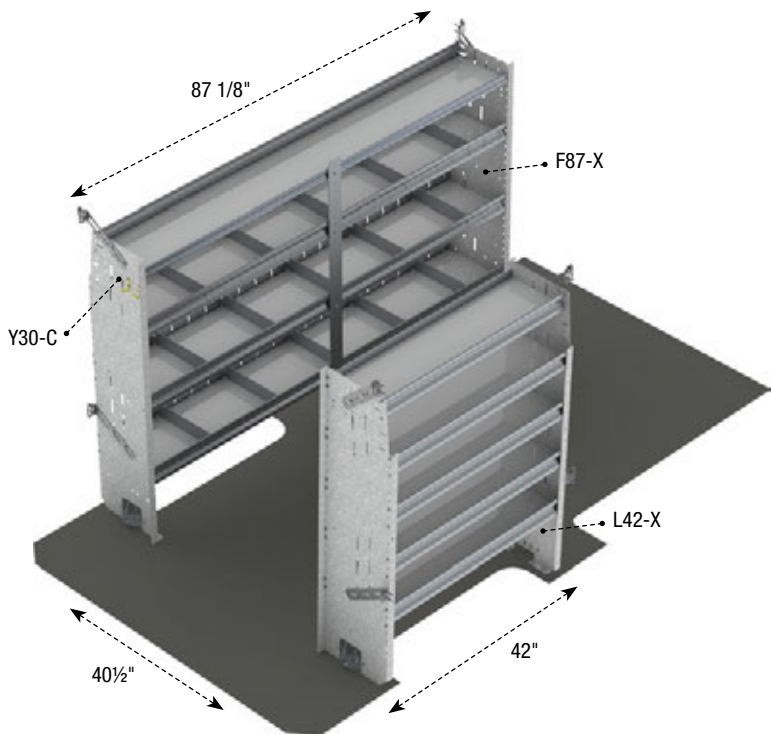

Z10-G2 Contractor Package

Steel

144"	Low/High Roof	207 lbs
2.4 hrs	No	

Qty	Part #	Description
1	F87-X	Square Back Shelving Unit
1	L42-X	Square Back Open Shelf Unit
2	Y30-C	Coat Hook

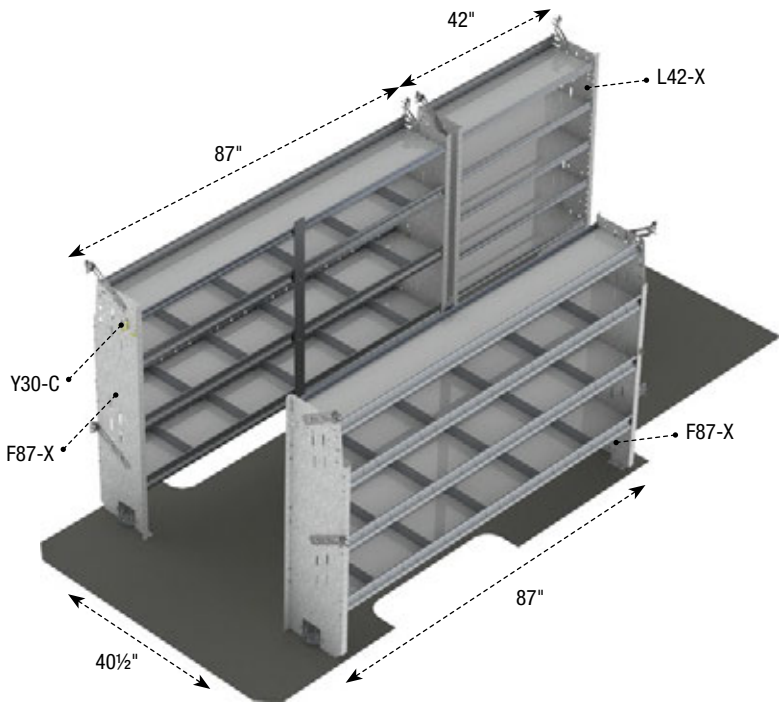

Z10-G7 Contractor Package

Steel

170", 170" Ext	High Roof	332 lbs
3.4 hrs	No	

Qty	Part #	Description
2	F87-X	Square Back Shelving Unit
1	L42-X	Square Back Open Shelf Unit
2	Y30-C	Coat Hook

Efficient layout lets you find everything quickly and easily.



*Preproduction model shown, do not use as an installation guide.



EFFICIENT

Ergonomic design reduces injuries and increases productivity.



QUIET

The combination of the extrusion shelf tray and end-panels create durable, vibration-free shelves.



TOUGH

Extrusion builds durability into shelf.

ELECTRICAL/TELECOM PACKAGES

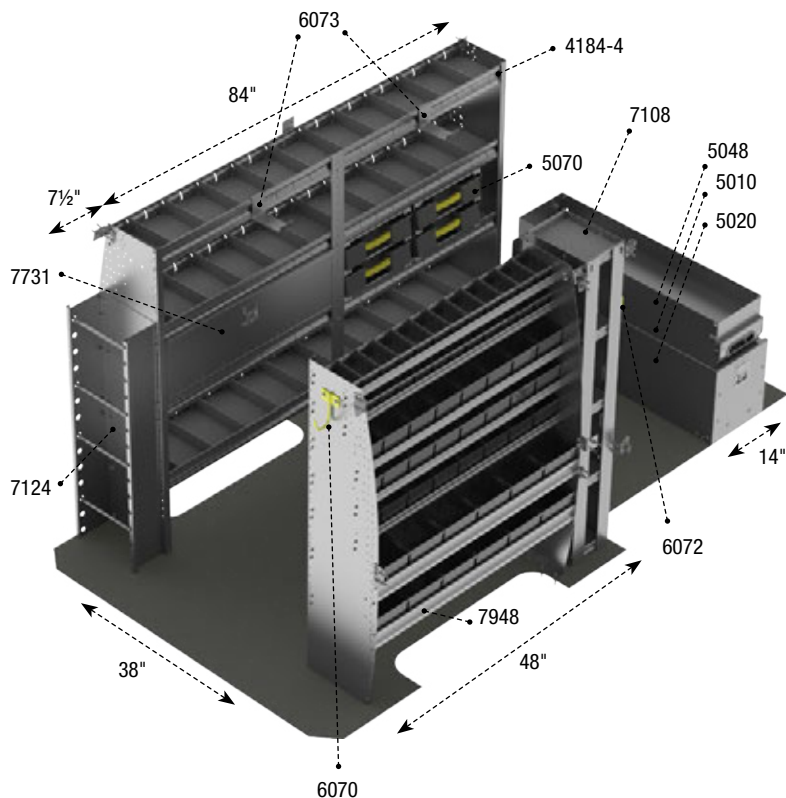

G211 Electrical/Telecom Package

Aluminum

144"	Low/High Roof	379 lbs
8.1 hrs	No	

Qty	Part #	Description
1	4184-4	Countoured Shelf Unit
1	5010	Partslider 48" Deep
1	5020	Tool Drawers
1	5048	Top Edge
4	5070	Partskeeper
1	6070	Fixed Hook
1	6072	Swivel Hook
2	6073	Large Removable Hook
1	7108	Bookshelf
2	7124	Reel Holder
1	7731	Shelving Locker 39.875" W x 12.063" H
1	7948	Countoured Bin Unit

PACKAGES

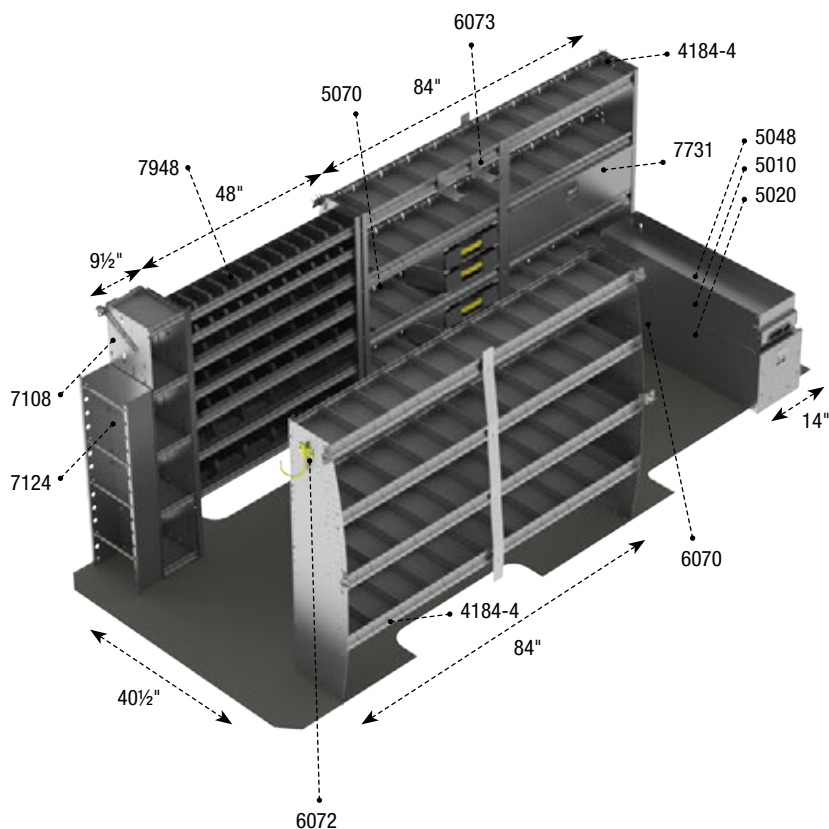

G711 Electrical/Telecom Package

Aluminum

170", 170" Ext	High Roof	467 lbs
9.5 hrs	No	

Qty	Part #	Description
2	4184-4	Countoured Shelf Unit
1	5010	Partslider 48" Deep
1	5020	Tool Drawer
1	5048	Top Edge
4	5070	Partskeeper
1	6070	Fixed Hook
1	6072	Swivel Hook
2	6073	Large Removable Hook
1	7108	Bookshelf
2	7124	Reel Holder
1	7731	Shelving Locker 39.875" W x 12.063" H
1	7948	Countoured Bin Unit

Efficient layout lets you find everything quickly and easily.



G212

HVAC Package



QUIET
The combination of the extrusion shelf tray and end-panels create durable, vibration-free shelves.



EFFICIENT
Ergonomic design reduces injuries and increases productivity.



TOUGH
Extrusion builds durability into shelf.

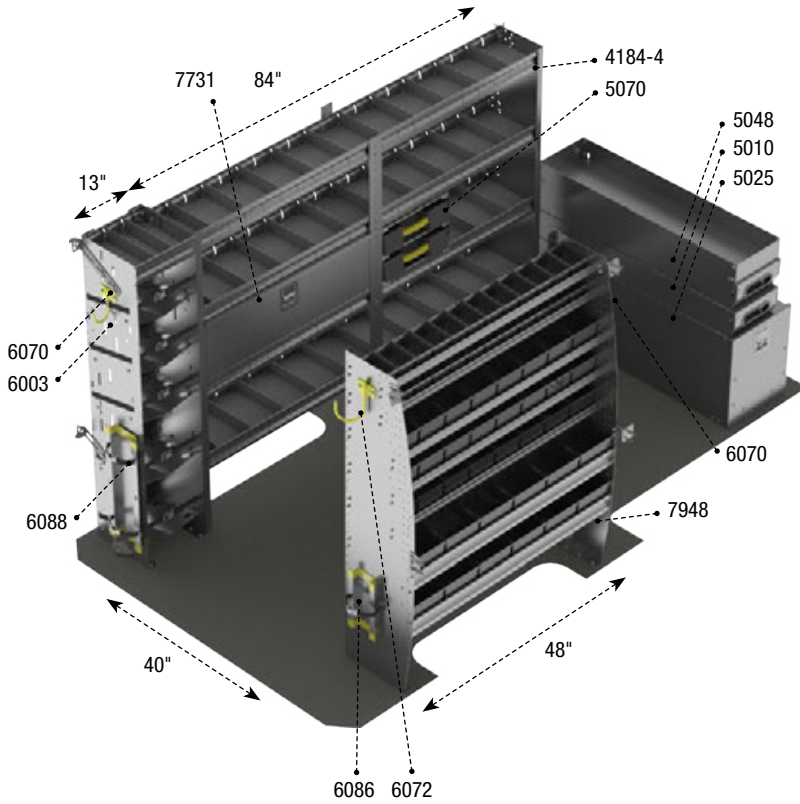

G212 HVAC Package

Aluminum

144"	Low/High Roof	400 lbs
8 hrs	No	

Qty	Part #	Description
1	4184-4	Countoured Shelf Unit
2	5010	Partslider 48" Deep
1	5025	Jumbo Tool Drawer
1	5048	Top Edge
2	5070	Partskeeper
1	6003	5 Tier Freon Rack - Small & Large Bottles
2	6070	Fixed Hook
1	6072	Swivel Hook
1	6086	Small Bottle Holder
1	6088	Large Bottle Holder
1	7731	Shelving Locker 39.875" W x 12.063" H
1	7948	Countoured Bin Unit

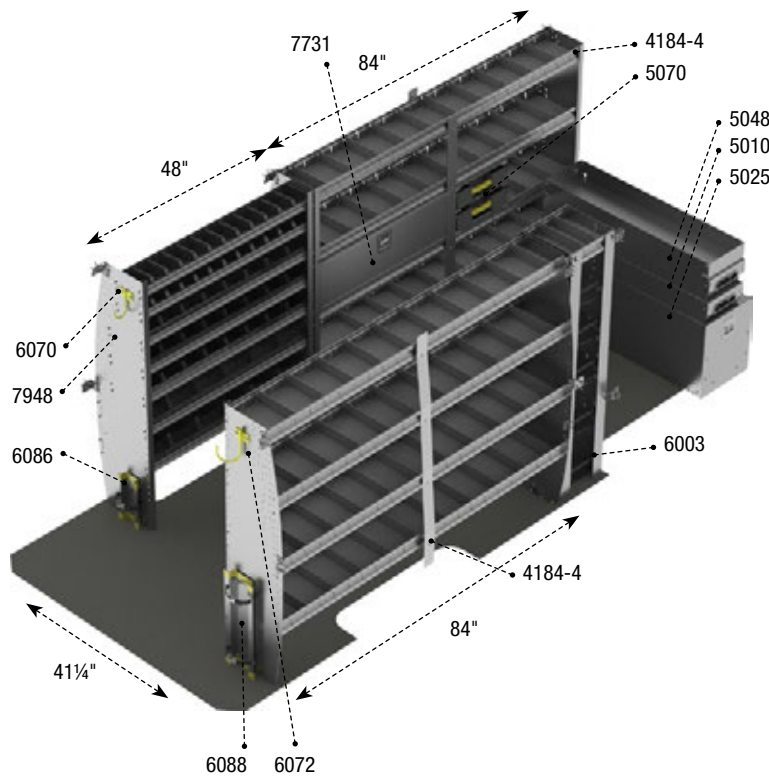

G712 HVAC Package

Aluminum

170", 170" Ext	High Roof	488 lbs
9.4 hrs	No	

Qty	Part #	Description
2	4184-4	Countoured Shelf Unit
2	5010	Partslider 48" Deep
1	5025	Jumbo Tool Drawer
1	5048	Top Edge
2	5070	Partskeeper
1	6003	5 Tier Freon Rack - Small & Large Bottles
1	6070	Fixed Hook
1	6072	Swivel Hook
1	6086	Small Bottle Holder
1	6088	Large Bottle Holder
1	7731	Shelving Locker 39.875" W x 12.063" H
1	7948	Countoured Bin Unit

Efficient layout lets you find everything quickly and easily.



G216

Service Package

*Preproduction model shown, do not use as an installation guide.



QUIET

The combination of the extrusion shelf tray and end-panels create durable, vibration-free shelves.



EFFICIENT

Ergonomic design reduces injuries and increases productivity.



TOUGH

Extrusion builds durability into shelf.

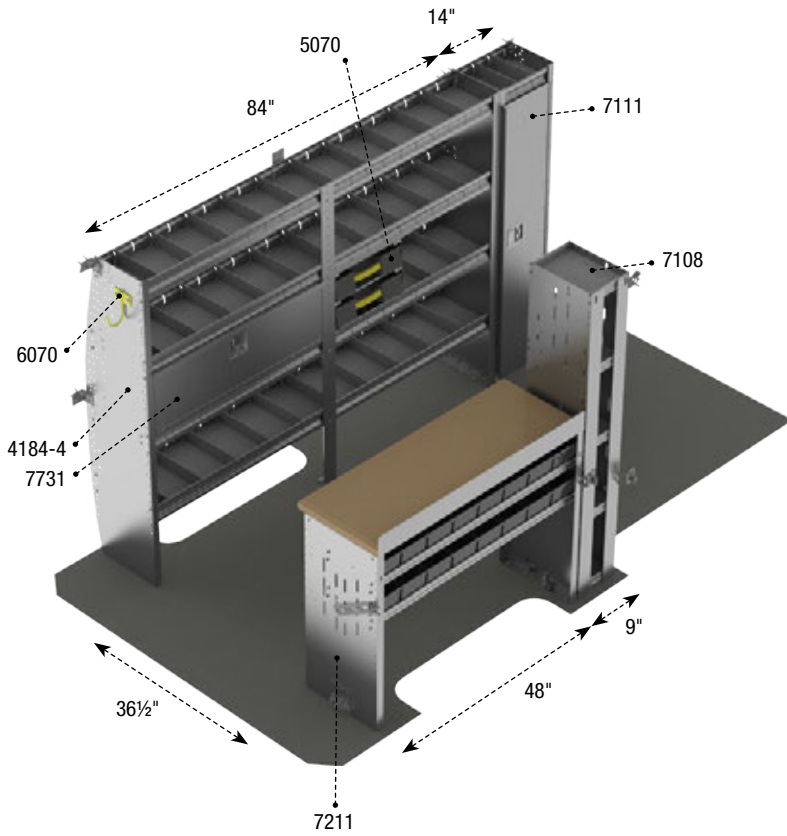

G216 Service Package

Aluminum

144"	Low/High Roof	250 lbs
5.2 hrs	No	

Qty	Part #	Description
1	4184-4	Countoured Shelf Unit
2	5070	Partskeeper
1	6070	Fixed Hook
1	7108	Bookshelf
1	7111	Locker Unit
1	7211	Workbench
1	7731	Aluminum Locking Door

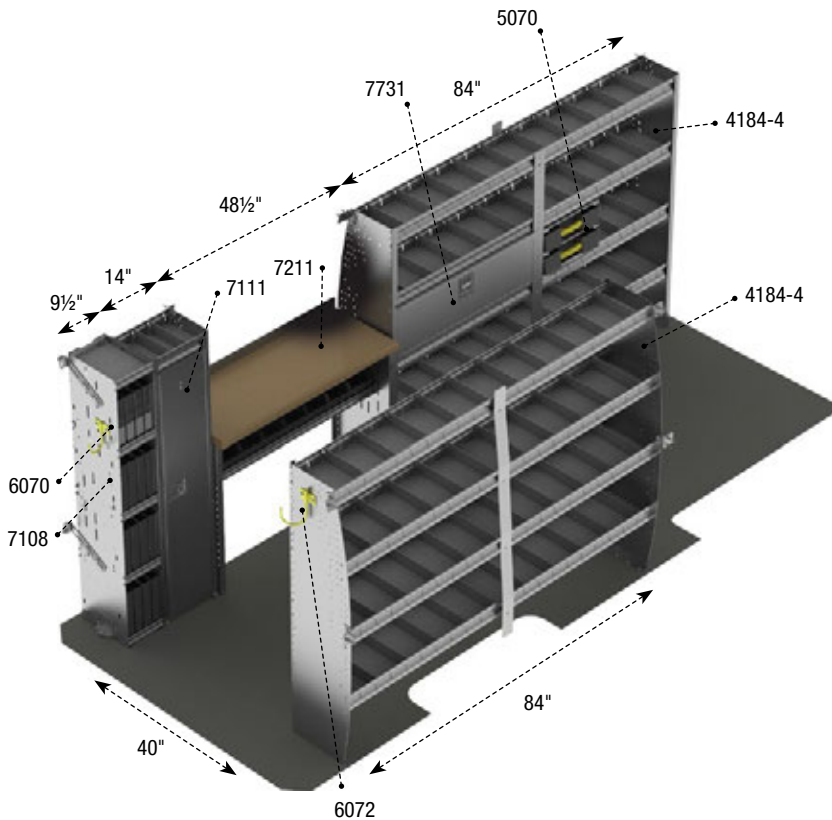

G716 Service Package

Aluminum

170", 170" Ext	High Roof	338 lbs
6.6 hrs	No	

Qty	Part #	Description
2	4184-4	Countoured Shelf Unit
2	5070	Partskeeper
1	6070	Fixed Hook
1	6072	Swivel Hook
1	7108	Bookshelf
1	7111	Locker Unit
1	7211	Workbench
1	7731	Shelving Locker 39.875" W x 12.063" H



Efficient layout lets you find everything quickly and easily.

G217

Service Package

*Preproduction model shown, do not use as an installation guide.



QUIET
The combination of the extrusion shelf tray and end-panels create durable, vibration-free shelves.



EFFICIENT
Ergonomic design reduces injuries and increases productivity.



TOUGH
Extrusion builds durability into shelf.

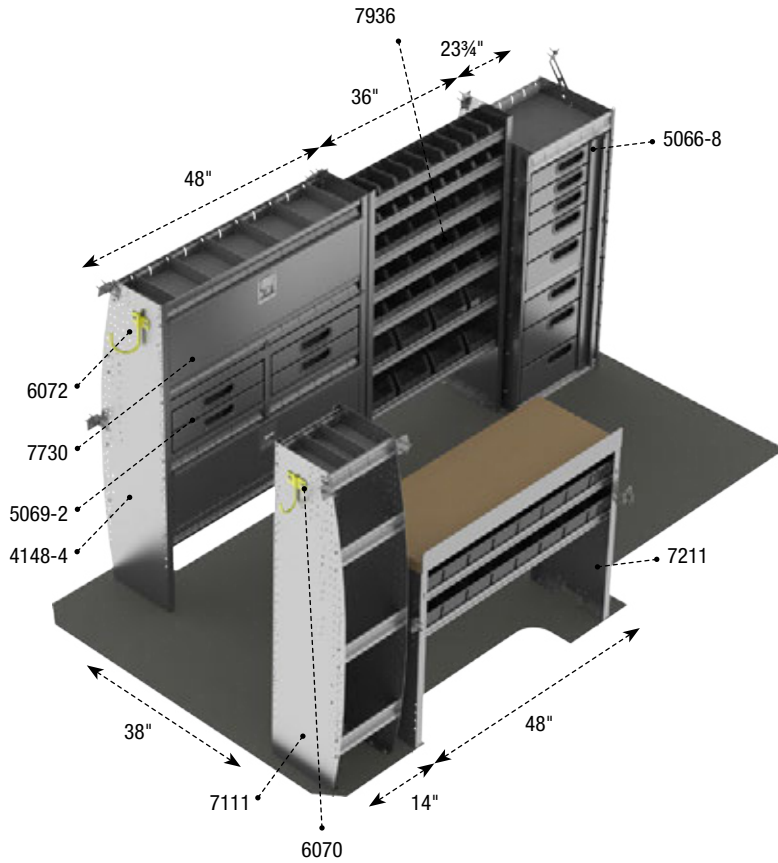

G217 Service Package

Aluminum

144"	Low/High Roof	518 lbs
8 hrs	No	

Qty	Part #	Description
1	4148-4	Countoured Shelf Unit
1	5066-8	8 Drawer Cabinet
2	5069-2	2 Drawer Cabinet
1	6070	Fixed Hook
1	6072	Swivel Hook
1	7111	Locker Unit
1	7211	Workbench
2	7730	Aluminum Locking Door
1	7936	Countoured Bin Unit

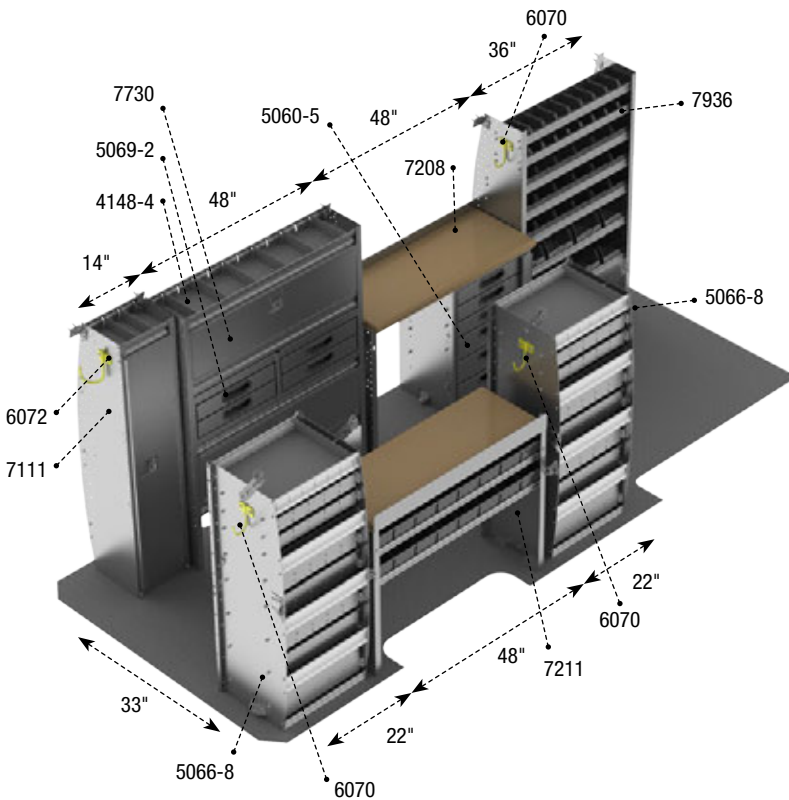

G717 Service Package

Aluminum

170", 170" Ext	High Roof	837 lbs
10.5 hrs	No	

Qty	Part #	Description
1	4148-4	Countoured Shelf Unit
1	5060-5	5 Drawers + 1 Door Cabinet
2	5066-8	8 Drawer Cabinet
2	5069-2	2 Drawer Cabinet
3	6070	Fixed Hook
1	6072	Swivel Hook
1	7111	Locker Unit
1	7208	Workbench
1	7211	Workbench
2	7730	Aluminum Locking Door
1	7936	Countoured Bin Unit



*Preproduction model shown, do not use as an installation guide.

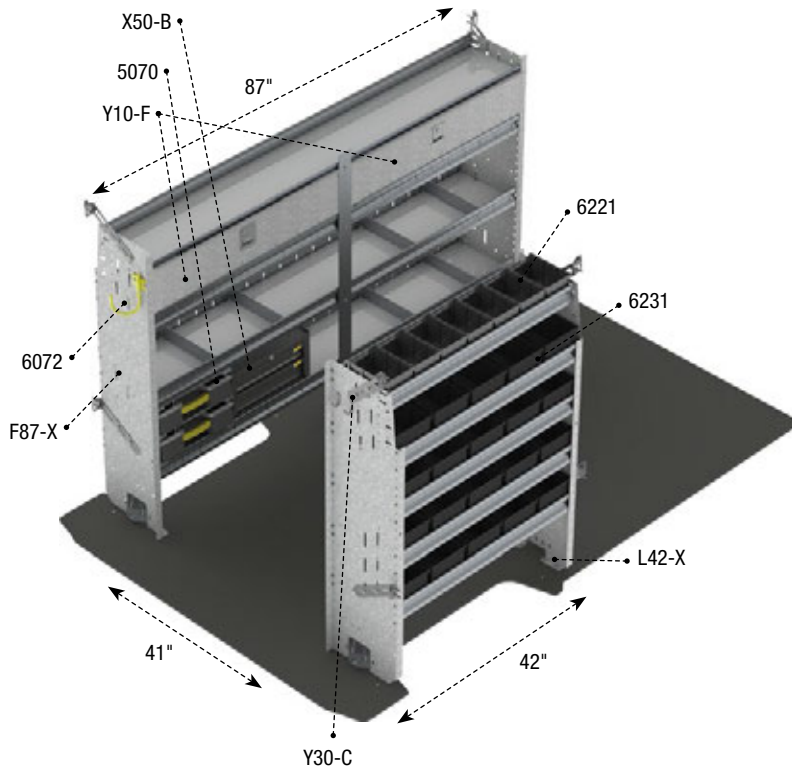

Z16-G2 Service Package

Steel

144"

Low/High Roof

295 lbs

4.5 hrs

No

Qty	Part #	Description
2	5070	Partskeeper
1	6072	Swivel Hook
1	L42-X	Square Back Shelving Unit
1	F87-X	Square Back Shelving Unit
1	X50-B	Fleetline 2 Drawer Unit
2	Y10-F	Y Series Locking Doors
2	Y30-C	Coat Hook
7	6221	Medium Bin - Black
20	6231	Large Bin

PACKAGES

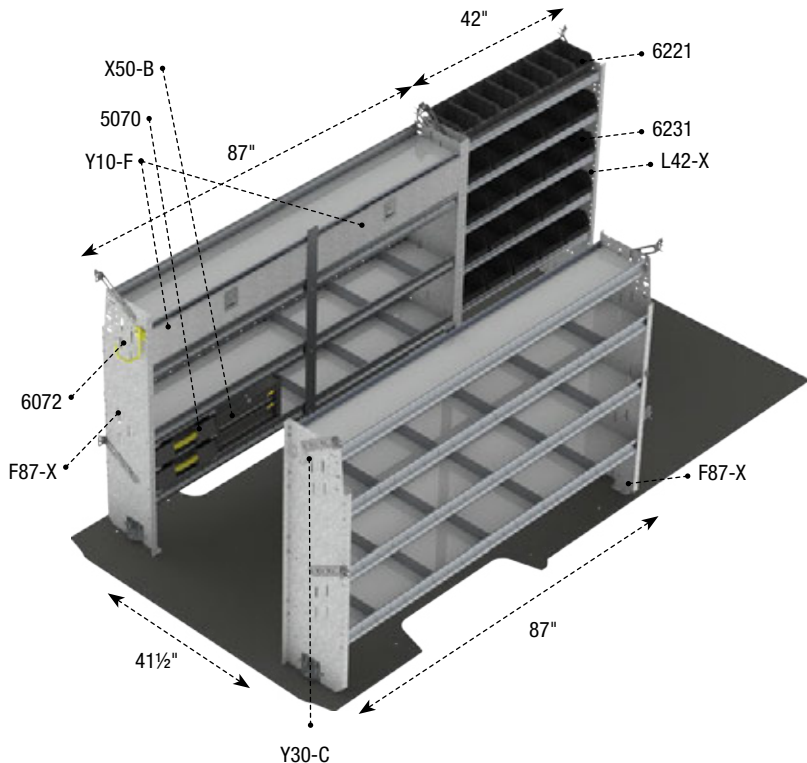

Z16-G7 Service Package

Steel

170", 170" Ext

High Roof

420 lbs

5.5 hrs

No

Qty	Part #	Description
2	5070	Partskeeper
1	6072	Swivel Hook
2	F87-X	Square Back Shelving Unit
1	L42-X	Square Back Open Shelf Unit
1	X50-B	Fleetline 2 Drawer Unit
2	Y10-F	Y Series Locking Doors
2	Y30-C	Coat Hook
7	6221	Medium Bin - Black
20	6231	Large Bin

Efficient layout lets you find everything quickly and easily.



G719

Delivery Package



QUIET

The combination of the extrusion shelf tray and end-panels create durable, vibration-free shelves.



EFFICIENT

Ergonomic design reduces injuries and increases productivity.

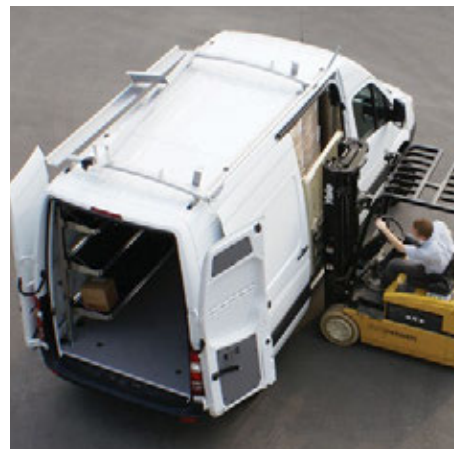

TOUGH

Extrusion builds durability into shelf.

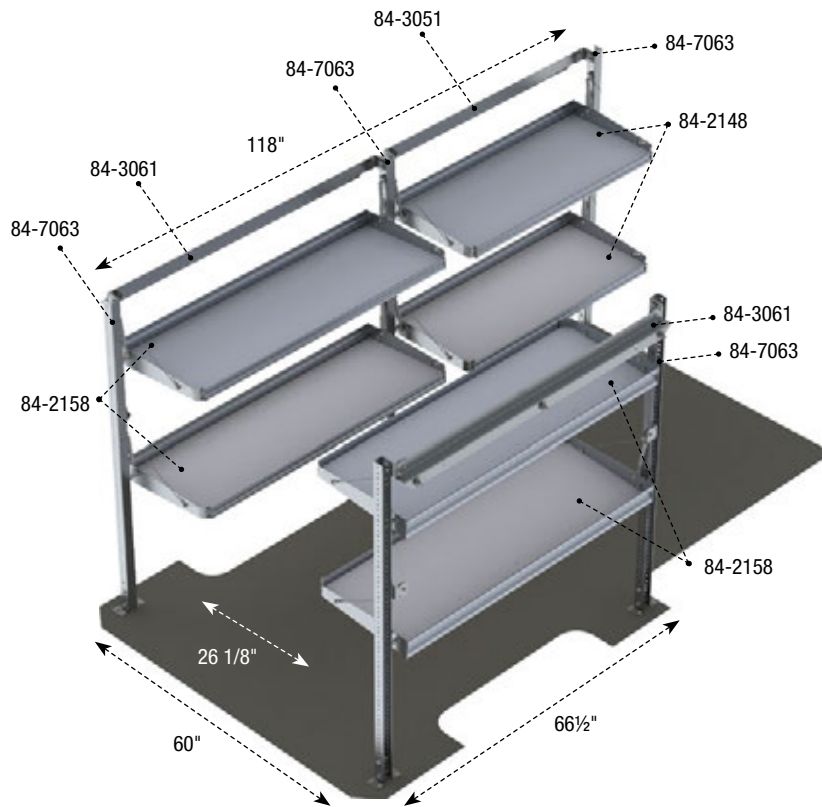

G219

Delivery Package

Aluminum

144"	Low/High Roof	181 lbs
3.9 hrs	No	

Qty	Part #	Description
2	84-2148	Shelf - Fold-Away Shelving Unit - 21" x 48"
4	84-2158	Shelf - Fold-Away Shelving Unit - 21" x 58"
1	84-3051	Mounting Bar - 51"Lg For Fold-Away Shelving Unit: 48"W
2	84-3061	Mounting Bar - 61"Lg For Fold-Away Shelving Unit: 58"W
5	84-7063	Post Assembly - Two Fold-Away Aluminum W/ Steel Foot, 63 1/2"H

PACKAGES

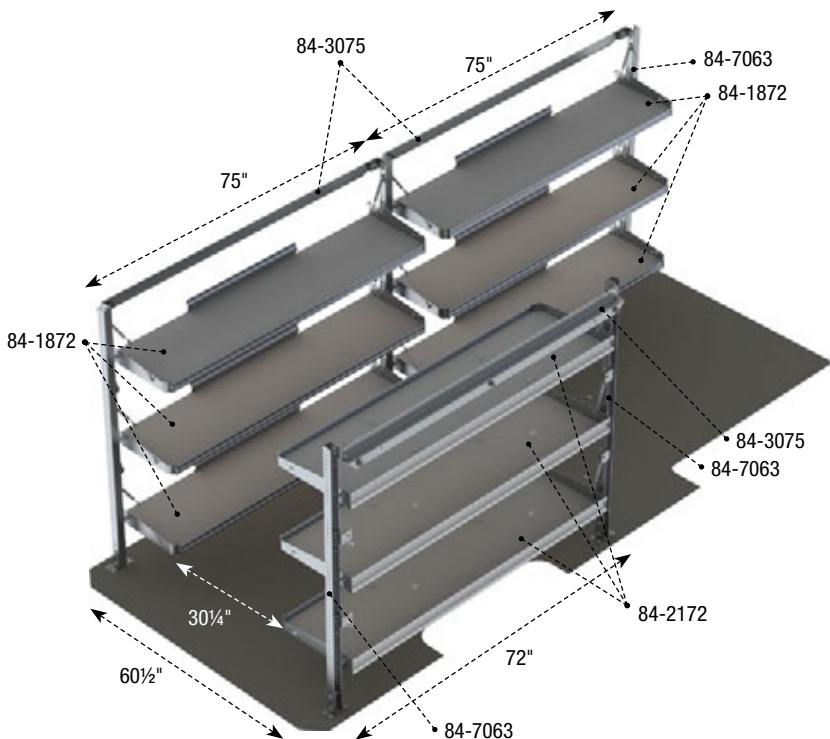

G719

Delivery Package

Aluminum

170", 170" Ext	High Roof	221 lbs
4.2 hrs	No	

Qty	Part #	Description
6	84-1872	Shelf - Fold-Away Shelving Unit - 18" x 72"
3	84-2172	Shelf - Fold-Away Shelving Unit - 21" x 72"
3	84-3075	Mounting Bar - 75"Lg For Fold-Away Shelving Unit: 72"W
5	84-7063	Post Assembly - Two Fold-Away Aluminum W/ Steel Foot, 63 1/2"H

Efficient layout lets you find everything quickly and easily.



G215

Plumber Package



QUIET

The combination of the extrusion shelf tray and end-panels create durable, vibration-free shelves.



EFFICIENT

Ergonomic design reduces injuries and increases productivity.



TOUGH

Extrusion builds durability into shelf.

PLUMBER PACKAGES

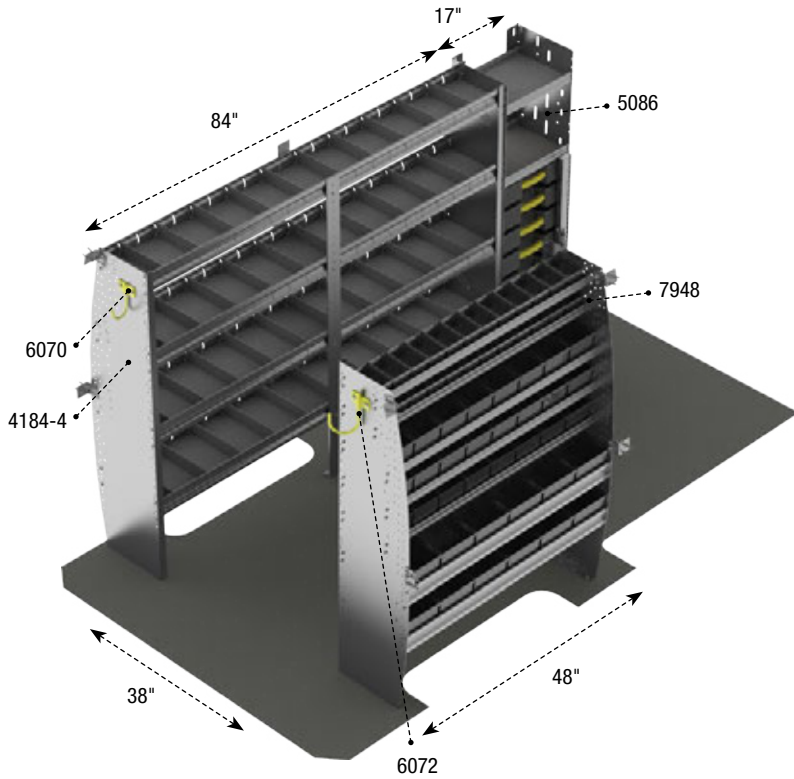

G215 Plumber Package

Aluminum

144"	Low/High Roof	269 lbs
4.2 hrs	No	

Qty	Part #	Description
1	4184-4	Countoured Shelf Unit
1	5086	Partskeeper Cabinet With 8 Carry Cases & 2 Shelves
1	6070	Fixed Hook
1	6072	Swivel Hook
1	7948	Countoured Bin Unit

PACKAGES

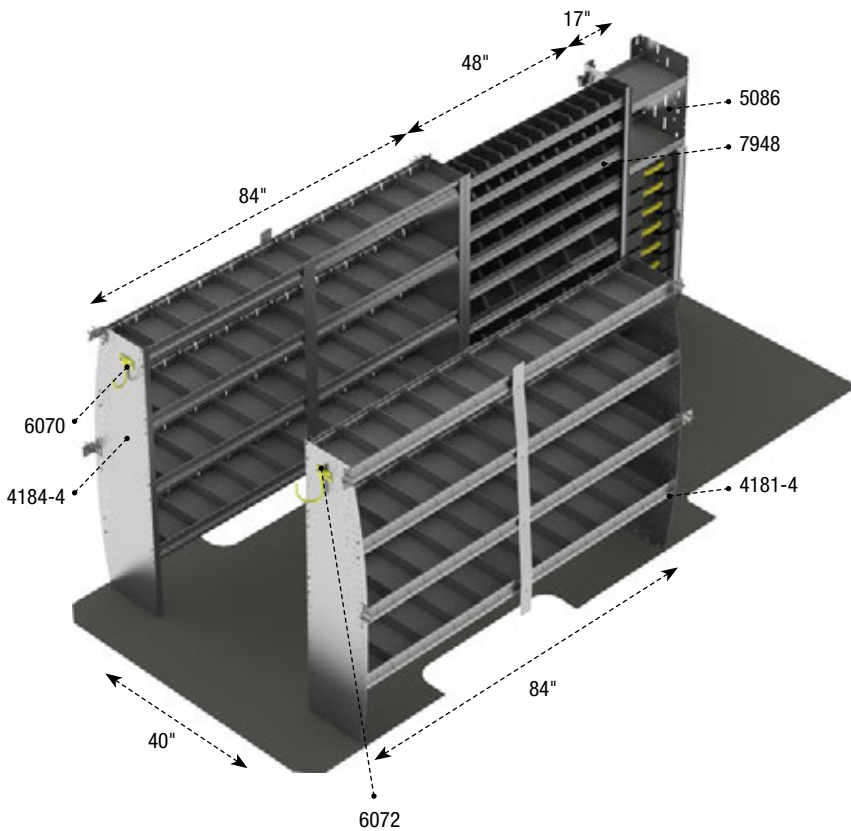

G715 Plumber Package

Aluminum

170", 170" Ext	High Roof	357 lbs
5.6 hrs	No	

Qty	Part #	Description
2	4184-4	Countoured Shelf Unit
1	5086	Partskeeper Cabinet With 8 Carry Cases & 2 Shelves
1	6070	Fixed Hook
1	6072	Swivel Hook
1	7948	Countoured Bin Unit



SHELVING

Industry leading strength.
The perfect fit for the toughest jobs.



TOUGH

Extrusion builds durability into shelf.



QUIET

Shelf tray and end panel are engineered to be vibration free.

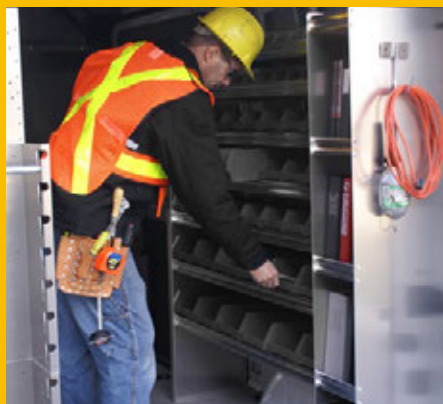

EFFICIENT

Ergonomics reduce injuries and increase productivity.

SHELVING

CONTOURED UNITS

CONTOURED BIN SHELVING UNIT P. 36

CONTOURED REFRIGERANT BIN UNIT P. 36

CONTOURED SHELVING UNIT W/ DIVIDERS P. 37

DEEP SQUARE BACK UNITS

DEEP SQ. BACK BIN SHELVING UNIT P. 40

DEEP SQ. BACK SHELVING UNIT P. 40

DEEP SQ. BACK SHELVING UNIT W/ DIVIDERS P. 41

FOLD-AWAY SHELVING P. 41

SQUARE BACK UNITS

SQUARE BACK BIN SHELVING UNIT P. 42

SQUARE BACK SHELVING UNIT P. 42

SQUARE BACK SHELVING UNIT W/ DIVIDERS P. 43

BOOKSHELF P. 43

LOCKER P. 44

WORKBENCH P. 44

DOORS P. 45

Ranger Design shelving is built strong and durable, often outlasts the vehicle and can be transferred to a newer van or truck. Designed to fit with maximum efficiency, Ranger shelving optimizes the space in a work van's cargo area.



SHELVING

Contoured Bin Shelving Unit

Aluminum



Sprinter
Low Roof



Sprinter
High Roof



7936	15.5" D x 36" W x 62.5" H	99 lbs			18 (sm), 18 (md), 8 (lrg)	1.4 hrs	No
7948	15.5" D x 48" W x 62.5" H	123 lbs			24 (sm), 24 (md), 12 (lrg)	1.4 hrs	No
7960	15.5" D x 60" W x 62.5" H	143 lbs			30 (sm), 30 (md), 14 (lrg)	1.4 hrs	Yes



Contoured Bin Shelving Unit

Aluminum



Sprinter
High Roof



8936-7	15.5" D x 36" W x 72" H	100 lbs			18 (sm), 18 (md), 8 (lrg)	1.4 hrs	No
8948-7	15.5" D x 48" W x 72" H	124 lbs			24 (sm), 24 (md), 12 (lrg)	1.4 hrs	No
8960-7	15.5" D x 60" W x 72" H	144 lbs			30 (sm), 30 (md), 14 (lrg)	1.4 hrs	No



Contoured Bin Shelving Unit

Aluminum



Sprinter
High Roof



8936-8	15.5" D x 36" W x 72" H	112 lbs			18 (sm), 18 (md), 12 (lrg)	1.4 hrs	No
8948-8	15.5" D x 48" W x 72" H	140 lbs			24 (sm), 24 (md), 18 (lrg)	1.4 hrs	No
8960-8	15.5" D x 60" W x 72" H	164 lbs			30 (sm), 30 (md), 21 (lrg)	1.4 hrs	No



Contoured Refrigerant Bin Unit

Aluminum



Sprinter
Low Roof



Sprinter
High Roof



5748	16" D x 48" W x 62.5" H	106 lbs			24 (sm), 24 (md)	1.2 hrs	No
5760	16" D x 60" W x 62.5" H	120 lbs			30 (sm), 30 (md)	1.2 hrs	No



Contoured Refrigerant Bin Unit

Aluminum



Sprinter
High Roof



8748	15.5" D x 48" W x 72" H	107 lbs			24 (sm), 24 (md)	1.4 hrs	No
8760	15.5" D x 60" W x 72" H	121 lbs			30 (sm), 30 (md)	1.4 hrs	No



Contoured Shelving Unit with Dividers

Aluminum



Sprinter
Low Roof



Sprinter
High Roof



4136-4	16" D x 36" W x 62.5" H	46 lbs	4 Shelves (10", 11", 13", 13")	24	7733	1.2 hrs	No
4148-4	16" D x 48" W x 62.5" H	56 lbs	4 Shelves (10", 11", 13", 13")	24	7730	1.2 hrs	No
4160-4	16" D x 60" W x 62.5" H	66 lbs	4 Shelves (10", 11", 13", 13")	32	7732	1.2 hrs	No



Contoured Shelving Unit with Dividers

Aluminum



Sprinter
Low Roof



Sprinter
High Roof



4136-5	16" D x 36" W x 62.5" H	53 lbs	5 Shelves (10", 11", 13", 13", 13")	30	7728	1.2 hrs	No
4148-5	16" D x 48" W x 62.5" H	65 lbs	5 Shelves (10", 11", 13", 13", 13")	30	7725	1.2 hrs	No
4160-5	16" D x 60" W x 62.5" H	78 lbs	5 Shelves (10", 11", 13", 13", 13")	40	7727	1.2 hrs	Yes



Contoured Shelving Unit with Dividers

Aluminum



Sprinter
Low Roof



Sprinter
High Roof



4172-4	16" D x 72" W x 62.5" H	76 lbs	4 Shelves (10", 11", 13", 13")	40	7733	1.4 hrs	No
4184-4	16" D x 84" W x 62.5" H	88 lbs	4 Shelves (10", 11", 13", 13")	40	N/A	1.4 hrs	No
4196-4	16" D x 96" W x 62.5" H	98 lbs	4 Shelves (10", 11", 13", 13")	48	7730	1.4 hrs	No



SHELVING

Contoured Shelving Unit with Dividers

Aluminum



Sprinter
Low Roof



Sprinter
High Roof



4172-5	16" D x 72" W x 62.5" H	90 lbs	5 Shelves (10", 11", 13", 13", 13")	50	7728	1.4 hrs	No
4184-5	16" D x 84" W x 62.5" H	102 lbs	5 Shelves (10", 11", 13", 13", 13")	50	N/A	1.4 hrs	Yes
4196-5	16" D x 96" W x 62.5" H	118 lbs	5 Shelves (10", 11", 13", 13", 13")	60	7725	1.4 hrs	No



Contoured Shelving Unit with Dividers

Aluminum



Sprinter
High Roof



8848-5	15.5" D x 48" W x 72" H	66 lbs	5 Shelves (8", 11", 12", 13", 13")	30	7725	1.3 hrs	No
8860-5	15.5" D x 60" W x 72" H	79 lbs	5 Shelves (8", 11", 12", 13", 13")	40	7727 or 7732	1.3 hrs	No



Contoured Shelving Unit with Dividers

Aluminum



Sprinter
High Roof



8848-6	15.5" D x 48" W x 72" H	75 lbs	6 Shelves (8", 11", 12", 13", 13", 13")	36	7720	1.3 hrs	No
8860-6	15.5" D x 60" W x 72" H	91 lbs	6 Shelves (8", 11", 12", 13", 13", 13")	48	7722	1.3 hrs	No



Contoured Shelving Unit with Dividers

Aluminum



Sprinter
High Roof



8872-5	15.5" D x 72" W x 72" H	91 lbs	5 Shelves (8", 11", 12", 13", 13")	40	7728	1.3 hrs	No
8884-5	15.5" D x 84" W x 72" H	103 lbs	5 Shelves (8", 11", 12", 13", 13")	50	N/A	1.3 hrs	No
8896-5	15.5" D x 96" W x 72" H	119 lbs	5 Shelves (8", 11", 12", 13", 13")	60	7725	1.3 hrs	No



FULLY OPTIMIZE SPACE IN YOUR HIGH ROOF VAN

RANGER DESIGN Tall shelving

- Contoured to fit tightly to the wall of the vehicle to maximize aisle space

84 series p.**43**
87 series p.**37**
88 series p.**38**
89 series p.**36**

COMPETITOR Shelving

- Shorter
- Not fitted to the wall of the vehicle, reducing aisle space

RANGER DESIGN Regular shelving

- Contoured to fit tightly to the wall of the vehicle to maximize aisle space

F series p.**41**
41 series p.**37**
57 series p.**36**
79 series p.**36**
84-2 series p.**41**

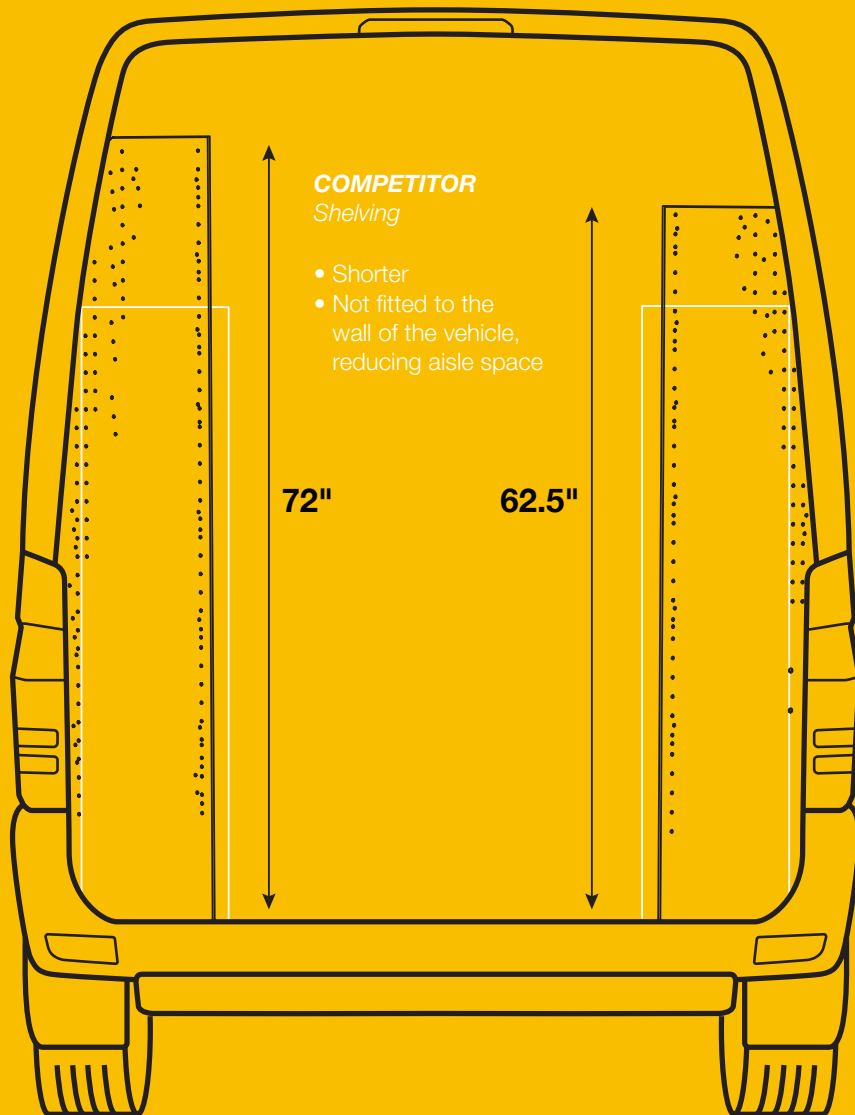

SHELVING

Contoured Shelving Unit with Dividers

Aluminum



Sprinter High Roof



8872-6	15.5" D x 72" W x 72" H	105 lbs	6 Shelves (8", 11", 12", 13", 13", 13")	48	7723	1.3 hrs	No
8884-6	15.5" D x 84" W x 72" H	117 lbs	6 Shelves (8", 11", 12", 13", 13", 13")	60	N/A	1.3 hrs	No
8896-6	15.5" D x 96" W x 72" H	139 lbs	6 Shelves (8", 11", 12", 13", 13", 13")	72	7720	1.3 hrs	No



Deep Square Back Bin Shelving Unit

Steel



Sprinter Low Roof



Sprinter High Roof



H38-T	17.5" D x 38" W x 58" H	93 lbs			Y11-D	1 hr	No
H42-T	17.5" D x 42" W x 58" H	100 lbs			Y11-F	1 hr	No
H56-T	17.5" D x 56" W x 58" H	120 lbs			Y11-J	1 hr	No
H70-T	17.5" D x 70" W x 58" H	140 lbs			Y11-C	1 hr	No

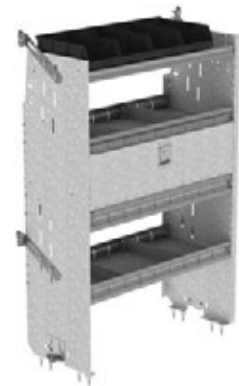

Deep Square Back Bin Shelving Unit

Steel



Sprinter Low Roof



Sprinter High Roof



H87-T	17.5" D x 87" W x 58" H	165 lbs			Y11-F	1 hr	No
--------------	-------------------------	---------	--	--	-------	------	----



Deep Square Back Shelving Unit

Steel



Sprinter Low Roof



Sprinter High Roof





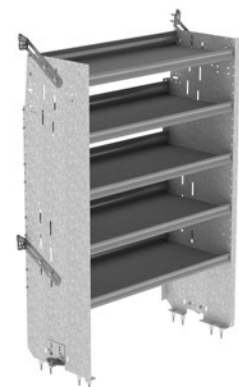





L38-T	17.5" D x 38" W x 58" H	88 lbs			Y10-D	1 hr	No
L42-T	17.5" D x 42" W x 58" H	93 lbs			Y10-F	1 hr	No
L56-T	17.5" D x 56" W x 58" H	112 lbs			Y10-B	1 hr	No
L70-T	17.5" D x 70" W x 58" H	130 lbs			Y10-C	1 hr	No



Deep Square Back Shelving Unit









Steel

								
Sprinter Low Roof	Sprinter High Roof							
L87-T	17.5" D x 87" W x 58" H	154 lbs				Y10-F	1 hr	No



Deep Square Back Shelving Unit with Dividers









Steel

								
Sprinter Low Roof	Sprinter High Roof							
F38-T	17.5" D x 38" W x 58" H	80 lbs				Y11-D	1 hr	No
F42-T	17.5" D x 42" W x 58" H	85 lbs				Y11-F	1 hr	No
F56-T	17.5" D x 56" W x 58" H	101 lbs				Y11-J	1 hr	No
F70-T	17.5" D x 70" W x 58" H	115 lbs				Y11-C	1 hr	No



Deep Square Back Shelving Unit with Dividers





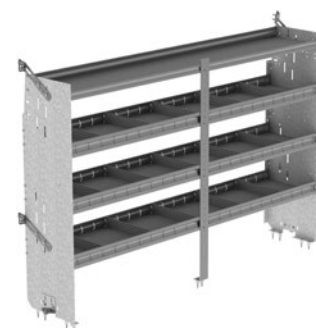



Steel

								
Sprinter Low Roof	Sprinter High Roof							
F87-T	17.5" D x 87" W x 58" H	136 lbs				Y11-F	1 hr	No



Fold-Away Shelving

Aluminum

								
Sprinter Low Roof	Sprinter High Roof							
8436-2	21" D x 43" W x 63.5" H	42 lbs		2 Shelves (20", 20")			1.2 hrs	No
8448-2	21" D x 55" W x 63.5" H	58 lbs		2 Shelves (20", 20")			1.2 hrs	Yes
8458-2	21" D x 65" W x 63.5" H	64 lbs		2 Shelves (20", 20")			1.3 hrs	Yes
8472-2	21" D x 79" W x 63.5" H	74 lbs		2 Shelves (20", 20")			1.4 hrs	Yes

*Weight capacity for fold-away shelving is 65 lbs / linear foot.



SHELVING

Fold-Away Shelving

Aluminum



Sprinter High Roof



8448-3	21" D x 55" W x 72" H	74 lbs	3 Shelves (17", 20", 20")			1.6 hrs	No
8458-3	21" D x 65" W x 72" H	83 lbs	3 Shelves (17", 17", 20")			1.7 hrs	No
8472-3	21" D x 79" W x 72" H	98 lbs	3 Shelves (17", 17", 20")			1.8 hrs	Yes

*Weight capacity for fold-away shelving is 65 lbs / linear foot.



Square Back Bin Shelving Unit

Steel



Sprinter Low Roof



Sprinter High Roof



H38-X	14" D x 38" W x 58" H	80 lbs	4 Shelves (9", 13", 13", 13")	9	6	1 hr	No
H42-X	14" D x 42" W x 58" H	86 lbs	4 Shelves (9", 13", 13", 13")	9	7	1 hr	No
H56-X	14" D x 56" W x 58" H	103 lbs	4 Shelves (9", 13", 13", 13")	12	9	1 hr	No
H70-X	14" D x 70" W x 58" H	120 lbs	4 Shelves (9", 13", 13", 13")	12	11	1 hr	No

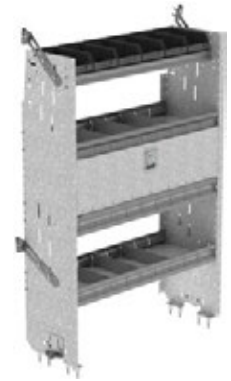

Square Back Bin Shelving Unit

Steel



Sprinter Low Roof



Sprinter High Roof



H87-X	14" D x 87" W x 58" H	145 lbs	4 Shelves (9", 13", 13", 13")	18	14	1 hr	No
--------------	-----------------------	---------	-------------------------------	----	----	------	----



Square Back Shelving Unit

Steel



Sprinter Low Roof



Sprinter High Roof



L38-X	14" D x 38" W x 58" H	78 lbs	5 Shelves (11", 13", 13", 13", 13")			1 hr	Yes
L42-X	14" D x 42" W x 58" H	82 lbs	5 Shelves (9", 13", 13", 13", 13")			1 hr	Yes
L56-X	14" D x 56" W x 58" H	99 lbs	5 Shelves (9", 13", 13", 13", 13")			1 hr	Yes
L70-X	14" D x 70" W x 58" H	115 lbs	5 Shelves (9", 13", 13", 13", 13")			1 hr	No



Square Back Shelving Unit

Steel



Sprinter Low Roof



Sprinter High Roof



L87-X	14" D x 87" W x 58" H	141 lbs	5 Shelves (9", 13", 13", 13", 13")			1 hr	No
--------------	-----------------------	---------	------------------------------------	--	--	------	----



Square Back Shelving Unit with Dividers

Steel



Sprinter Low Roof



Sprinter High Roof



F38-X	14" D x 38" W x 58" H	70 lbs	4 Shelves (9", 13", 13", 13")	9	Y12-D	1 hr	No
F42-X	14" D x 42" W x 58" H	74 lbs	4 Shelves (9", 13", 13", 13")	9	Y12-F	1 hr	Yes
F56-X	14" D x 56" W x 58" H	88 lbs	4 Shelves (9", 13", 13", 13")	12	Y12-J	1 hr	Yes
F70-X	14" D x 70" W x 58" H	102 lbs	4 Shelves (9", 13", 13", 13")	12	Y12-C	1 hr	Yes



Square Back Shelving Unit with Dividers

Steel



Sprinter Low Roof



Sprinter High Roof



F87-X	14" D x 87" W x 58" H	125 lbs	4 Shelves (9", 13", 13", 13")	18	Y12-F	1 hr	Yes
--------------	-----------------------	---------	-------------------------------	----	-------	------	-----



Bookshelf

Aluminum



Sprinter Low Roof



Sprinter High Roof



7108	14" D x 9" W x 62.5" H	30 lbs				0.5 hr	No
-------------	------------------------	--------	--	--	--	--------	----



SHELVING

7111

Contoured locker w/top shelf

Aluminum



Sprinter



16" D x 14" W x 62.5" H



35 lbs



1 hr



No

7210

Workbench w/hardwood top, 1 shelf w/door

Aluminum

UNIVERSAL



18" D x 48" W x 36" H



75 lbs



1.2 hrs



No

7208

Workbench w/hardwood top, one end panel (Drawer cabinet not included)

Aluminum

UNIVERSAL



18" D x 48" W x 36" H



47 lbs



0.5 hr



No

7211

Workbench w/hardwood top, 2 bin shelves

Aluminum

UNIVERSAL



18" D x 48" W x 36" H



75 lbs



1 hr



No

7209

Workbench w/hardwood top, 1 shelf

Aluminum

UNIVERSAL



18" D x 48" W x 36" H



65 lbs



1 hr







Yes



7208 Workbench with hardwood top mounted with a **5060-5** 5 Drawer cabinet







Shelving Doors

Aluminum					
		Use with shelf width			
7720	44.88" W x 8.69" H	48", 96"	7 lbs	0.5 hr	No
7722	56.88" W x 8.69" H	60"	9 lbs	0.5 hr	No
7723	32.88" W x 8.69" H	36", 72"	5 lbs	0.5 hr	No
7724	20.88" W x 8.69" H	24"	4 lbs	0.5 hr	No
7725	44.88" W x 10.38" H	48", 96"	8 lbs	0.5 hr	Yes
7727	56.88" W x 10.38" H	60"	9 lbs	0.5 hr	No
7728	32.88" W x 10.38" H	36", 72"	6 lbs	0.5 hr	Yes
7729	20.88" W x 10.38" H	24"	4 lbs	0.5 hr	No
7730	44.88" W x 12.06" H	48", 96"	8 lbs	0.5 hr	Yes
7731	38.88" W x 12.06" H	84"	8 lbs	0.5 hr	No
7732	56.88" W x 12.06" H	60"	10 lbs	0.5 hr	No
7733	32.88" W x 12.06" H	36", 72"	6 lbs	0.5 hr	No
7734	20.88" W x 12.06" H	24"	5 lbs	0.5 hr	No
7735	44.88" W x 13.75" H	48", 96"	9 lbs	0.5 hr	No
7737	56.88" W x 13.75" H	60"	11 lbs	0.5 hr	No
7738	32.88" W x 13.75" H	36", 72"	7 lbs	0.5 hr	No
7739	20.88" W x 13.75" H	24"	5 lbs	0.5 hr	No







Shelf Block

Closes the space behind shelving doors

Aluminum					
		Use with shelf width			
7740	12" W x From 11" to 16.5", adjustable	All	3 lbs	0.5 hr	No







Shelving Doors

Steel					
		Use with shelf width			
Y10-B	19.88" W x 8.69" H	56"	7 lbs	0.5 hr	No
Y10-C	34.88" W x 8.69" H	70"	9 lbs	0.5 hr	Yes
Y10-D	37.88" W x 8.69" H	38"	10 lbs	0.5 hr	No
Y10-F	41.88" W x 8.69" H	42", 87"	12 lbs	0.5 hr	Yes
Y10-H	47.88" W x 8.69" H	48"	14 lbs	0.5 hr	No
Y10-M	31.88" W x 8.69" H	32"	8 lbs	0.5 hr	No
Y11-C	34.88" W x 10.38" H	70"	10 lbs	0.5 hr	Yes
Y11-D	37.88" W x 10.38" H	38"	11 lbs	0.5 hr	Yes
Y11-E	35.88" W x 10.38" H	36"	10.5 lbs	0.5 hr	No
Y11-F	41.88" W x 10.38" H	42", 87"	13 lbs	0.5 hr	Yes
Y11-M	31.88" W x 10.38" H	32"	8 lbs	0.5 hr	No
Y12-C	34.88" W x 12.06" H	70"	10 lbs	0.5 hr	No
Y12-D	37.88" W x 12.06" H	38"	12 lbs	0.5 hr	No
Y12-F	47.88" W x 12.06" H	42", 87"	14 lbs	0.5 hr	No
Y12-M	31.88" W x 12.06" H	32"	8 lbs	0.5 hr	No



Shelving Doors

Steel					
		Use with shelf width			
Y10-J	55.88" W x 8.69" H	56"	15 lbs	0.5 hr	No
Y11-J	55.88" W x 10.38" H	56"	16 lbs	0.5 hr	No
Y12-J	55.88" W x 12.06" H	56"	17 lbs	0.5 hr	No





DRAWERS

Durable storage compartments, designed for quick and easy access.



TOUGH

Proline drawers are backed by a 10 year warranty.



QUICK

Easy to use slam latch.



SECURITY

Secure keyed lock.

DRAWERS

CAB BOXES P. 48
DRAWER CABINETS P. 48
PARTSKEEPERS P. 49
TOOL DRAWERS P. 50

Ranger manufactures a variety of tough, quiet drawer systems and storage modules. Using top quality components such as full-extension, high-capacity ball-bearing drawer slides, secure locks, and Ranger's unique braided stainless steel cable-pull handles. These drawers are the organizational quality that you deserve.

If you never again want to experience the frustration of drawers that jam, sag, and don't latch properly, we have the solution.



DRAWERS



5045

Cab box with locking lid

Aluminum

18" D x 12" W x 16" H

—

16 lbs

0.4 hr

No



5044

Raised base for 5045/
W40-A cab box, Sprinter

Aluminum

11.5" D x 22.5" W x 9" H

—

2 lbs

0.2 hr

No



W40-A

Fleetline cab box with locking lid

Steel

18" D x 12" W x 16" H

—

22 lbs

0.4 hr

No



5060-6

6 Drawer cabinet

Aluminum

18" D x 24" W x 36" H

150 lbs

114 lbs

1 hr

No



5066-8

8 Drawer cabinet

Aluminum

20.5" D x 24" W x 56" H

150 lbs

168 lbs

1 hr

No



5069-2

2 Drawer cabinet

Aluminum

14" D x 24" W x 12" H

150 lbs

34 lbs

0.5 hr

Yes



X50-B

Compact 2-Drawer Unit

Steel

12.5" D x 18.5" W x 10.5" H

—

19 lbs

0.3 hr

Yes



X50-C

Compact 3-Drawer Unit

Steel

12.5" D x 18.5" W x 10.5" H

—

20 lbs

0.3 hr

Yes



X51-F

Compact 9-Drawer Unit

Steel

12" D x 17" W x 12" H

—

26 lbs

0.3 hr

Yes



5070

Partskeeper carry case with holder, universal

Aluminum

14" D x 17" W x 5.5" H

—

7 lbs

0.3 hr

Yes



5086

Partskeeper cabinet with 8 carry cases & 2 shelves

Aluminum

14" D x 17" W x 62.5" H

—

57 lbs

1 hr

Yes



5010

Partslider drawer

Aluminum

48" D x 12" W x 6" H

150 lbs

30 lbs

0.5 hr

Yes

DRAWERS



5020

Tool drawer

Aluminum

48" D x 14" W x 16" H

320 lbs

46 lbs

1 hr

Yes



5025

Jumbo tool drawer

Aluminum

48" D x 16" W x 19" H

320 lbs

61 lbs

1 hr

Yes



5048

Top edge, for 5010 Partslider

Aluminum

48" D x 12" W x 4" H

—

5 lbs

0.2 hr

Yes

DRAWERS



5020 Tool drawer mounted with its complementary **5010** Partslider drawer and **5048** Top edge.

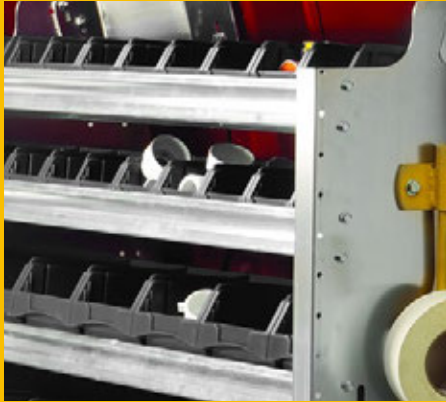

VERSATILE

Removable storage bins ensure organization on the jobsite or on the go.



SECURE

Trade specific accessories with a place for all tools and supplies.



PRODUCTIVE

Stay productive with the most used items well within reach.

ACCESSORIES

Choose the finishing details to tailor the upfit to your specific needs.

BOTTLE HOLDERS P. 52

HOOKS P. 52

OTHERS P. 52

PAPER HOLDERS P. 53

WINDOW GRILLS P. 54

BINS P. 54

The finishing details are just as important when you're setting up your commercial van as they are when you're on the job site. Customize your vehicle with our wide range of options to ensure that you can perform at peak efficiency.



ACCESSORIES



6001
4 Tier refrigerant rack for large bottles

Aluminum	
14" D x 13" W x 62.5" H	
34 lbs	
0.7 hr	
No	



6003
5 Tier refrigerant rack for large bottles

Aluminum	
14" D x 13" W x 62.5" H	
36 lbs	
0.7 hr	
Yes	



6010
Two level adjustable bottle holder

Aluminum	
10.25" D x 9.5" W x 36" H	
5 lbs	
0.4 hr	
No	



6020
Horizontal refrigerant bottle holder

Aluminum	
12.5" D x 48" W x 13" H	
17 lbs	
0.5 hr	
No	



6041
Locking cabinet

Aluminum	
15" D x 15.5" W x 33" H	
26 lbs	
0.7 hr	
No	



6049
Ventilation kit for cabinet

Aluminum	
—	
—	
—	
No	



6086
Small aluminum bottle holder, with a black nylon strap

Aluminum	
6" W x 12" H	
1 lb	
0.2 hr	
Yes	



6088
Large aluminum bottle holder, with two black nylon straps

Aluminum	
8" W x 24" H	
2 lbs	
0.2 hr	
Yes	



6070
6" Hook, 3" opening, painted

Steel	
3" D	
0.4 lb	
0.2 hr	
Yes	



6072
8" Swivel Hook, 4" opening, painted

Steel	
—	
0.6 lb	
0.2 hr	
Yes	



6073
Large aluminum movable hook, 6.5" opening

Aluminum	
6.5" D x 2.75" W x 4" H	
1 lb	
0.01 hr	
Yes	



Y30-C
Coat Hook, 1" opening, chrome plated

Steel	
1" D	
0.1 lb	
0.2 hr	
Yes	

ACCESSORIES



6052

Vise Holder with an 8"x8" mounting plate

Steel

	–
	37 lbs
	0.5 hr
	No



6057

Can Holder

Aluminum

	3" D x 8.5" W x 3" H
	1 lb
	0.2 hr
	No



6061

Paper Holder, extra deep, 2 slots

Aluminum

	3.75" D x 12.75" W x 12" H
	2 lbs
	0.2 hr
	No



6063

Paper Holder, extra deep, 5 slots

Aluminum

	3.75" D x 12.75" W x 24" H
	5 lbs
	0.2 hr
	Yes



Y31-A

Paper Holder, extra deep, 3 slots

Steel

	3.75" D x 12.75" W x 16" H
	9 lbs
	0.2 hr
	Yes

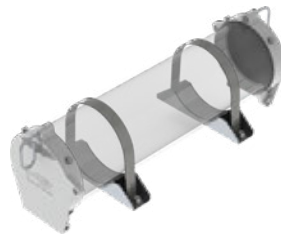

6079

Transport tube door kit complete

Aluminum

	6" D
	6 lbs
	0.8 hr
	No



7124

Reel Holder with two 5/8" diameter rods

Aluminum

	7.25" D x 15" W x 24" H
	9 lbs
	0.5 hr
	No



6068

Hard Hat Holder, painted wire

Steel

	–
	0.5 lb
	0.2 hr
	No



1130

Elevated strobe mount

Aluminum

	8" W
	1 lb
	0.1 hr
	No

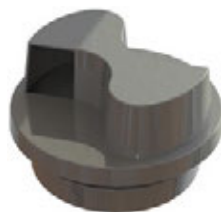

6050

Flettner vent, rotary design

Plastic

	8.9" D
	1.5 lbs
	1 hr
	No



6054

Hitch Step, comes with hitch pin to fit a 2"x2" hitch

Aluminum

	6" D x 12" W
	4 lbs
	–
	No



6082

Triangle kit with aluminum holder

Other

	–
	14 lbs
	0.2 hr
	No

ACCESSORIES



6093

Grab handle

Plastic

9.5" D

0.1 lb

0.5 hr

No



6221

Medium Bin, Graphite

Plastic

10" D x 6" W x 4.5" H

0.56 lb

-

Yes



6231

Large Bin, Graphite

Plastic

14" D x 8" W x 5.5" H

1.33 lbs

-

Yes



6107

Set of 2 rear window grills

Steel

Standard / High Roof

8 lbs

0.2 hr

No

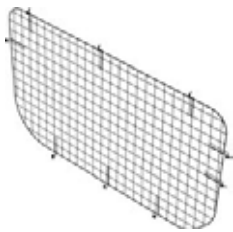

6117

Window grill, passenger side sliding door

Steel

Standard / High Roof

8 lbs

0.2 hr

No

INTRODUCING THE NEW RANGER DESIGN

SEAT COVERS



Our key advantages are:

- Tight custom fit for each vehicle
- Durable material and easy maintenance
- Urethane coating to make the fabric water and stain resistant
- Machine wash and dryer safe
- Easy installation within 30 minutes for a set
- No interference with factory seat functions: heat, cold, air bag
- Minimal seams
- Guaranteed to stay in place
- Puncture resistant
- Durable fabric with a 1 year warranty

6257

Seat covers

4 lbs

0.3 hr

No



TOUGH

Military grade aluminum extrusion, high density plastic and stainless steel components ensure no corrosion over the lifetime of the rack.



QUIET

Aerodynamic design with minimal wind noise.



SAFE

No metal contact to ladder, leading to longer life of ladders with less chance of fiberglass splinters.

LADDER RACKS

Ergonomic Ladder Racks make loading and unloading easier.

STANDARD LADDER RACK P. 56

CARGO RACK P. 56

MAX RACK P. 56

COMBINATION LADDER RACK P. 57

DOUBLE CLAMP LADDER RACK P. 57

ACCESSORY P. 57

Ranger ladder racks make loading and unloading ladders an easy operation. Ranger Design offers drop-down ladder racks for high roof vans, extra tough racks capable of carrying 28' ladders on compact vans, interior ladder carriers and many other options for different applications.



LADDER RACKS



Third bar crossbow kit for Max Rack

Aluminum

15-1805	Universal	Universal	72"	10 lbs	
----------------	-----------	-----------	-----	--------	--



Passenger Side Retrofit kit

Aluminum

15-1810	Universal	Universal		57 lbs	1 hr
----------------	-----------	-----------	--	--------	------



Driver Side Retrofit kit

Aluminum

15-1815	Universal	Universal		57 lbs	1 hr
----------------	-----------	-----------	--	--------	------



Handle Assembly for Max Rack

Aluminum

18-2507	Universal	Universal	66"		
----------------	-----------	-----------	-----	--	--



Cargo rack

Aluminum

1505-DH	Universal	High Roof	68"	480 lbs	20 lbs	0.8 hr
----------------	-----------	-----------	-----	---------	--------	--------



Standard ladder rack

Aluminum

1510-DH	Universal	High Roof	68"	400 lbs	21 lbs	0.9 hr
----------------	-----------	-----------	-----	---------	--------	--------



Single clamp ladder rack

Aluminum

1520-DH	Universal	High Roof	68"	400 lbs	30 lbs	1.2 hrs
----------------	-----------	-----------	-----	---------	--------	---------



Combination ladder rack

Aluminum						
1525-DH	Universal	High Roof	68"	400 lbs	48 lbs	1.7 hrs



Double clamp ladder rack

Aluminum						
1530-DH	Universal	High Roof	68"	400 lbs	49 lbs	1.7 hrs



Max Rack, Single side ladder rack

Aluminum						
1820-DH	Universal	High Roof	72"	100 lbs	82 lbs	2 hrs



Max Rack, Double side ladder rack

Aluminum						
1830-DH	Universal	High Roof	72"	200 lbs	139 lbs	3 hrs



Access Pro, Inside Ladder Carrier

Aluminum						
1050-FS	Universal	Universal	96"		9 lbs	1 hr



Ladder rack accessory

Aluminum						
1127	Universal	Universal			18 lbs	0.5 hr



RANGER LADDER RACKS

Upgrade your ladder rack with the addition of this third or fourth bar.

15-0527 Additional bar upgrade kit



MAX RACK

DESIGNED FOR HIGH ROOF VANS

SAFE & EASY TO USE

50" OF TRAVEL

The Max Rack drops lower in one movement than any other rack in the industry.

- Max Rack
- Competitor's rack

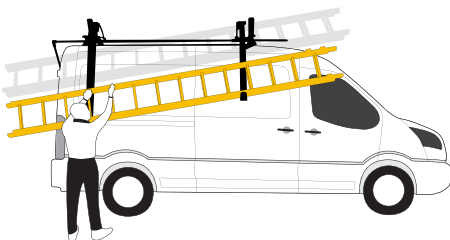

- › Two pressurized gas shocks support the weight of the ladder, assist in lifting and lowering the ladder and also hold it in the closed position.
- › Max Rack is adjustable to fit most ladders.

LOW PROFILE

There is less chances of the Max Rack hitting low hanging objects.



- › Ladders only touch composite materials, reducing ladder wear.
- › Comes down in one single motion.

EXTREME WEATHER PROOF

The Max Rack was put through extreme weather testing.



CYCLE TESTING

The Max Rack completed over 4300 cycles, which represents approximately 15 years of normal use.

MAX RACK IS FAST AND EASY TO OPERATE

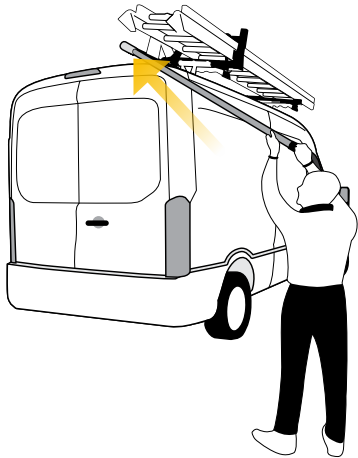

1

STEP ONE

With both hands, insert the control arm into the Max Rack.

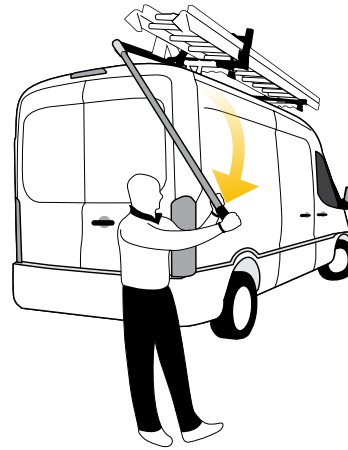

2

STEP TWO

Pull the control arm down towards you.

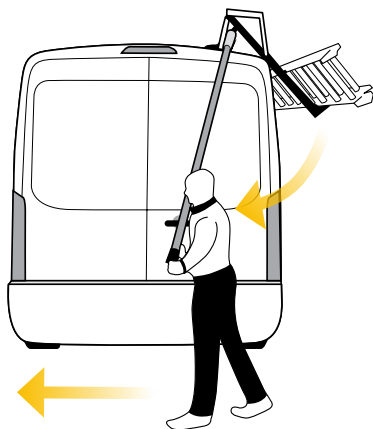

3

STEP THREE

Turn around. Push the control arm forward.

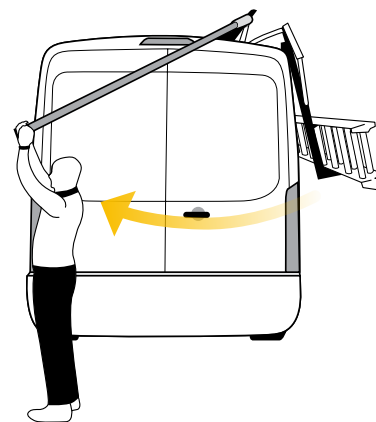

4

STEP FOUR

Continue to push the control arm until the Max Rack has finished its descent.

RACK CAPACITY



STEP LADDERS
8' AND 10'

Fits all Max Racks



The Max Rack can carry extension ladders up to 32' long.

Please verify the chart on page 4 for the maximum ladder length that the Max Rack can carry on your vehicle.

The weight capacity per single Max Rack is 100lbs.

Over 350 Distributors Across the Continent

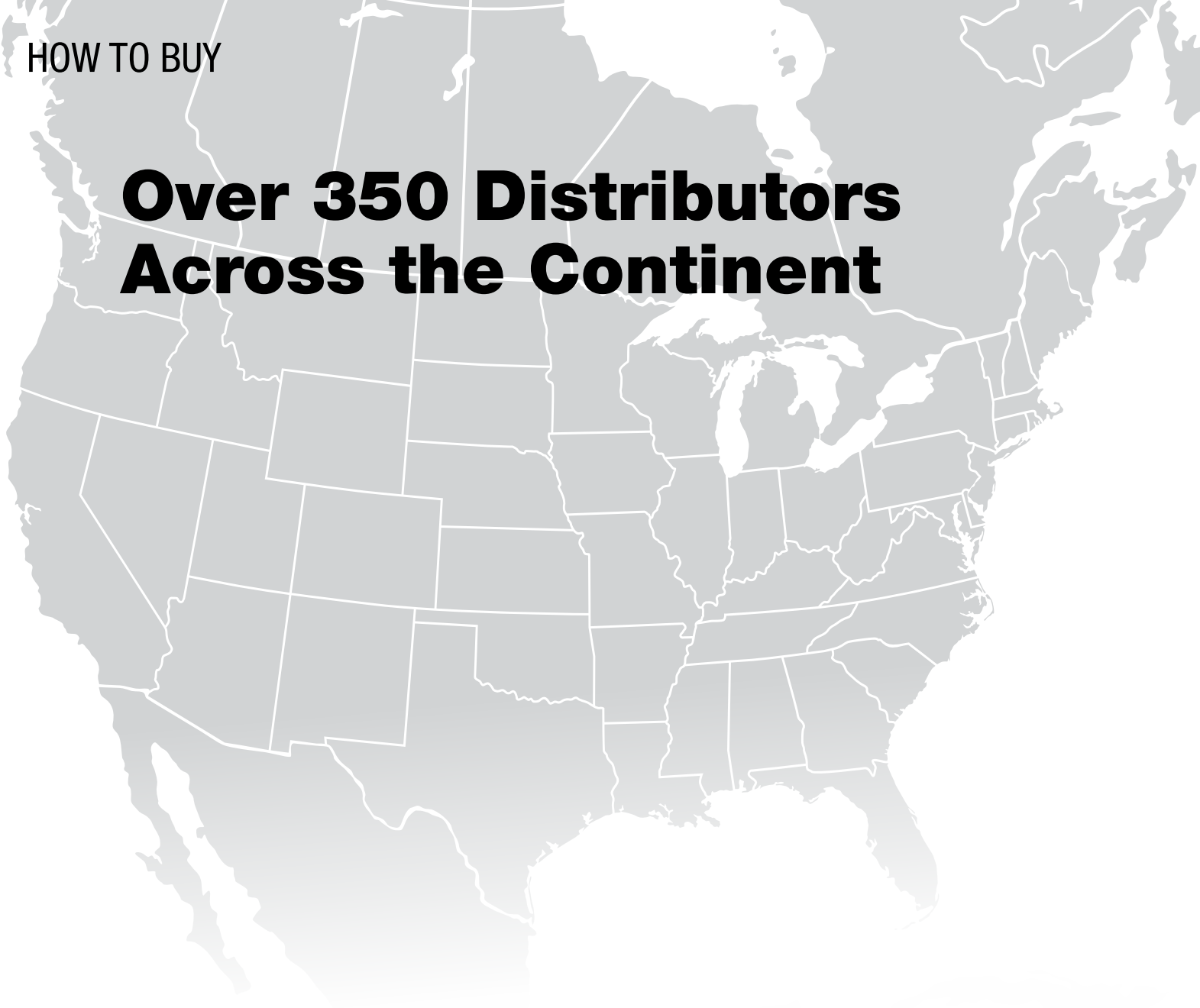

Regular Order

Quickship Order

How to Order

Contact one of our 300 distributors
rangerdesign.com/find-dealer.

Ranger Quickship service is available
through your local distributor.

Lead Time

Orders ship from our factory within
5 business days.

Orders placed with Ranger before 1PM EST will
ship from our factory in the next business day.



Throughout the catalog products and packages with this symbol can be ordered through our Quickship service.

Turn-Key Fleet Services



Ship Through or Local Installation Across North America for all Types of Cargo Vans

We are pleased to offer efficient, personalized service and to answer all questions regarding:

1. Analysis

- › Cargo Needs Analysis
- › Custom 3D CAD Layouts
- › Hands-on Equipment Demo

2. Testing

- › Test Fitting
- › Pilot Build and Review
- › Optimize Package Based on Technician Feedback

3. Delivery

- › Delivery, Production and Installation Planning and Scheduling
- › Vehicle Status Tracking

4. Service

- › Dedicated Fleet Account Management Team
- › 300 Ranger Dealers Service Support Network
- › Live Customer Service

INDEX

1050-FS	57	5069-2	48	7732	45	F70-T	41
1127	57	5070	49	7733	45	F70-X	43
1130	53	5086	49	7734	45	F87-T	41
15-1805	56	5748	36	7735	45	F87-X	43
15-1810	56	5760	36	7737	45	G210	18
15-1815	56	6001	52	7738	45	G211	21
1505-DH	56	6003	52	7739	45	G212	23
1510-DH	56	6010	52	7740	45	G215	33
1520-DH	56	6020	52	7936	36	G216	25
1525-DH	57	6041	52	7948	36	G217	27
1530-DH	57	6049	52	7960	36	G219	31
18-2507	56	6050	53	8436-2	41	G710	18
1820-DH	57	6052	53	8448-2	41	G711	21
1830-DH	57	6054	53	8448-3	42	G712	23
3010-DH	13	6057	53	8458-2	41	G715	33
3010-DL	13	6061	53	8458-3	42	G716	25
3015-DH	15	6063	53	8472-2	41	G717	27
3020-DH	13	6068	53	8472-3	42	G719	31
3020-DL	13	6070	52	8748	37	H38-T	31
3025-DH	13	6072	52	8760	37	H38-X	42
3060-DH	14	6073	52	8848-5	38	H42-T	40
3060-DL	14	6079	53	8848-6	38	H42-X	42
3064-DH	14	6082	53	8860-5	38	H56-T	40
3064-DL	14	6086	52	8860-6	38	H56-X	42
3068-DH	14	6088	52	8872-5	38	H70-T	40
3068-DL	14	6093	54	8872-6	40	H70-X	42
3069-DH	15	6107	54	8884-5	38	H87-T	40
3069-DL	15	6117	54	8884-6	40	H87-X	42
4136-4	37	6221	54	8896-5	38	L38-T	40
4136-5	37	6231	54	8896-6	40	L38-X	42
4148-4	37	6257	54	8936-7	36	L42-T	40
4148-5	37	7108	43	8936-8	36	L42-X	42
4160-4	37	7111	44	8948-7	36	L56-T	40
4160-5	37	7124	53	8948-8	36	L56-X	42
4172-4	37	7208	44	8960-7	36	L70-T	40
4172-5	38	7209	44	8960-8	36	L70-X	42
4184-4	37	7210	44	C20-DH	12	L87-T	41
4184-5	38	7211	44	C20-DL	12	L87-X	43
4196-4	37	7720	45	C24-DH	12	W40-A	48
4196-5	38	7722	45	C24-DL	12	X50-B	45
5010	49	7723	45	C30-DH	12	X50-C	45
5020	50	7724	45	C30-DL	12	X51-F	45
5025	50	7725	45	F38-T	41	Y10-B	45
5044	48	7727	45	F38-X	43	Y10-C	45
5045	48	7728	45	F42-T	41	Y10-D	45
5048	50	7729	45	F42-X	43	Y10-F	45
5060-6	48	7730	45	F56-T	41	Y10-H	45
5066-8	48	7731	45	F56-X	43	Y10-J	45

Y10-M45	Y11-M.....45	Y30-C52	Z10-G7.....19
Y11-C.....45	Y12-C.....45	Y31-A53	Z16-G2.....29
Y11-D.....45	Y12-D.....45	X50-B.....49	Z16-G7.....29
Y11-E.....45	Y12-F.....45	X50-C49	
Y11-F.....45	Y12-J.....45	X51-F49	
Y11-J.....45	Y12-M.....45	Z10-G2.....19	



NEED HELP WITH YOUR ORDER

Contact us at cs@rangerdesign.com
or call **1-800-565-5321**

Ask us for our other Mercedes-Benz
product related catalogs.

Maximize Cargo Capacity & Vehicle Performance With Contractor Grade, Organized Storage Systems

When you want the perfect upfit solution for your work vehicle, turn to Ranger Design. Crash-tested for toughness, Ranger's shelving and upfits will take whatever abuse you can dish out. Their unsurpassed craftsmanship, combined with ideal fit and finish, provide a quiet ride with no rattles.



CUSTOMER SERVICE

cs@rangerdesign.com

1-800-565-5321

www.rangerdesign.com



THE PERFECT FIT
FOR YOUR TOUGHEST JOBS