

REVISIONS			DATE	DWN	CHK
ZONE	REV	DESCRIPTION			
A		RELEASED PER ECN 1103725			

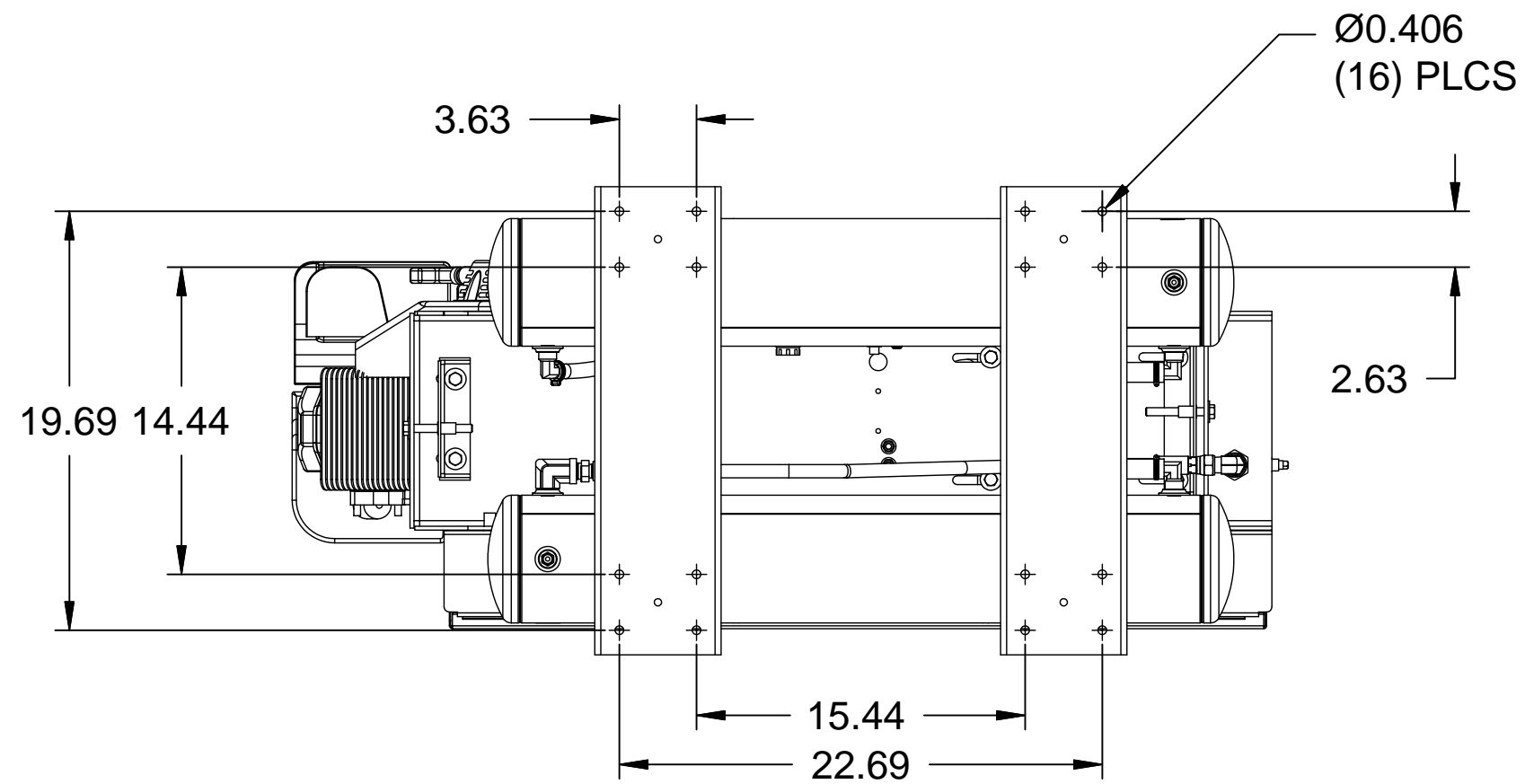
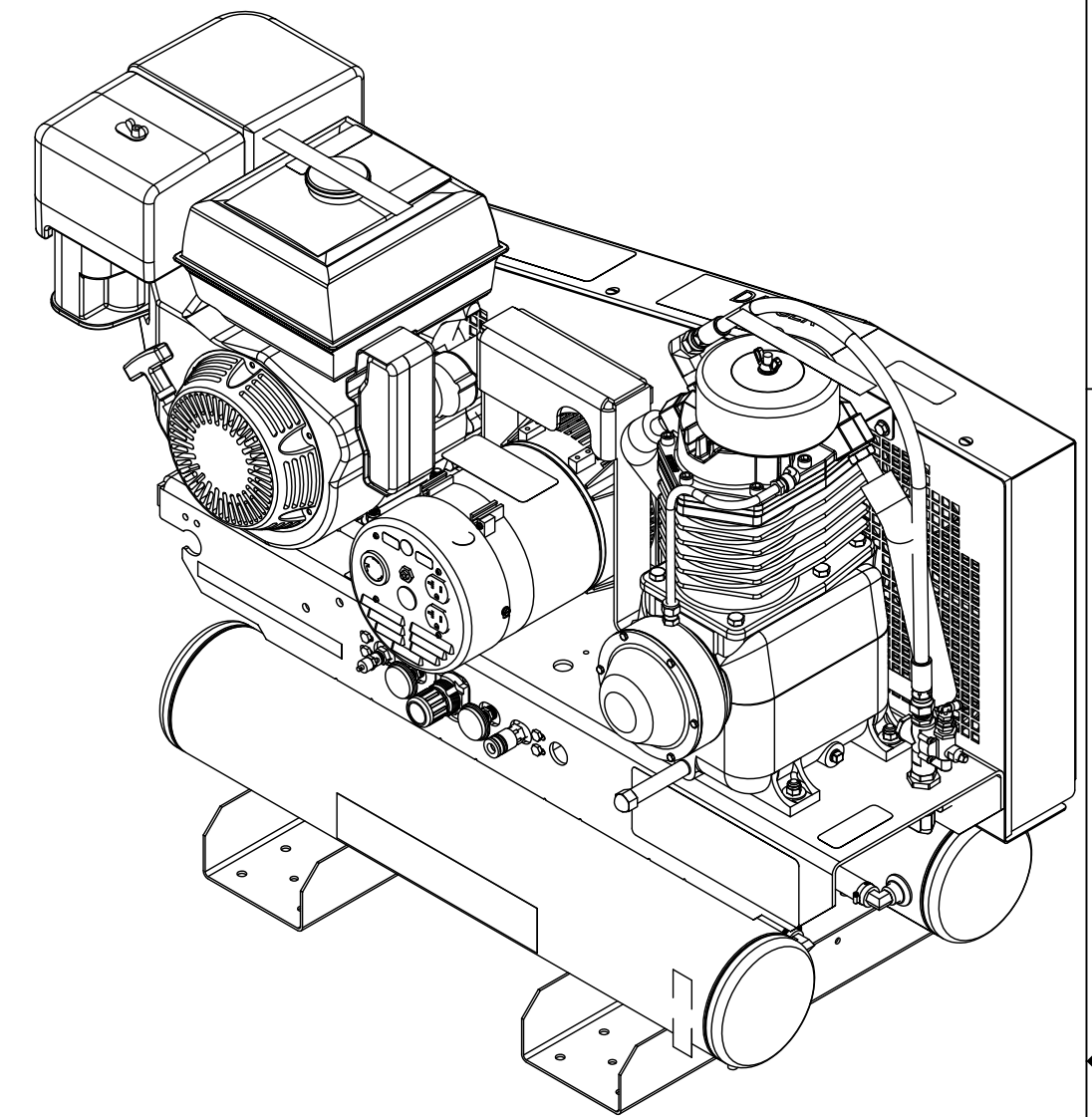
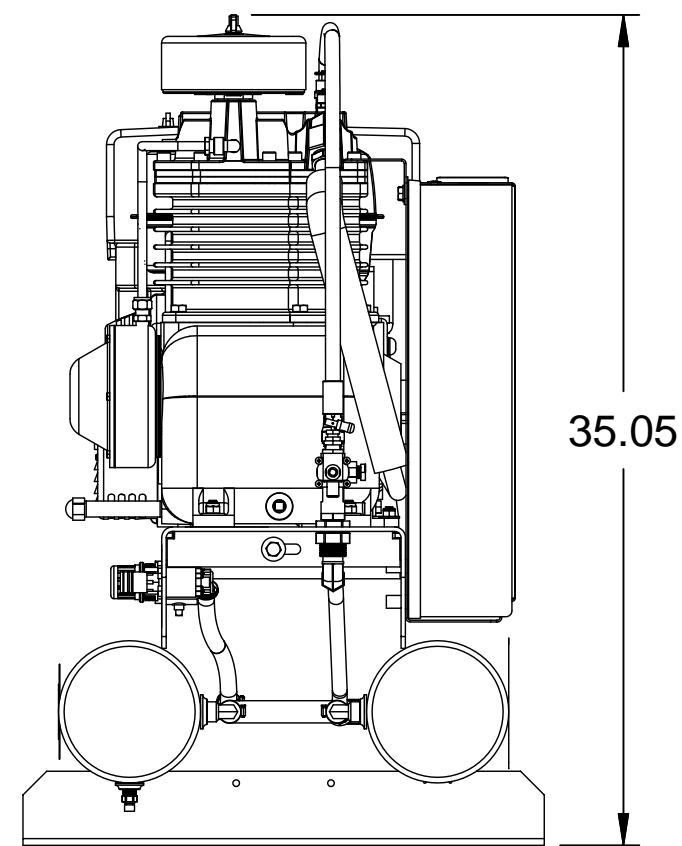
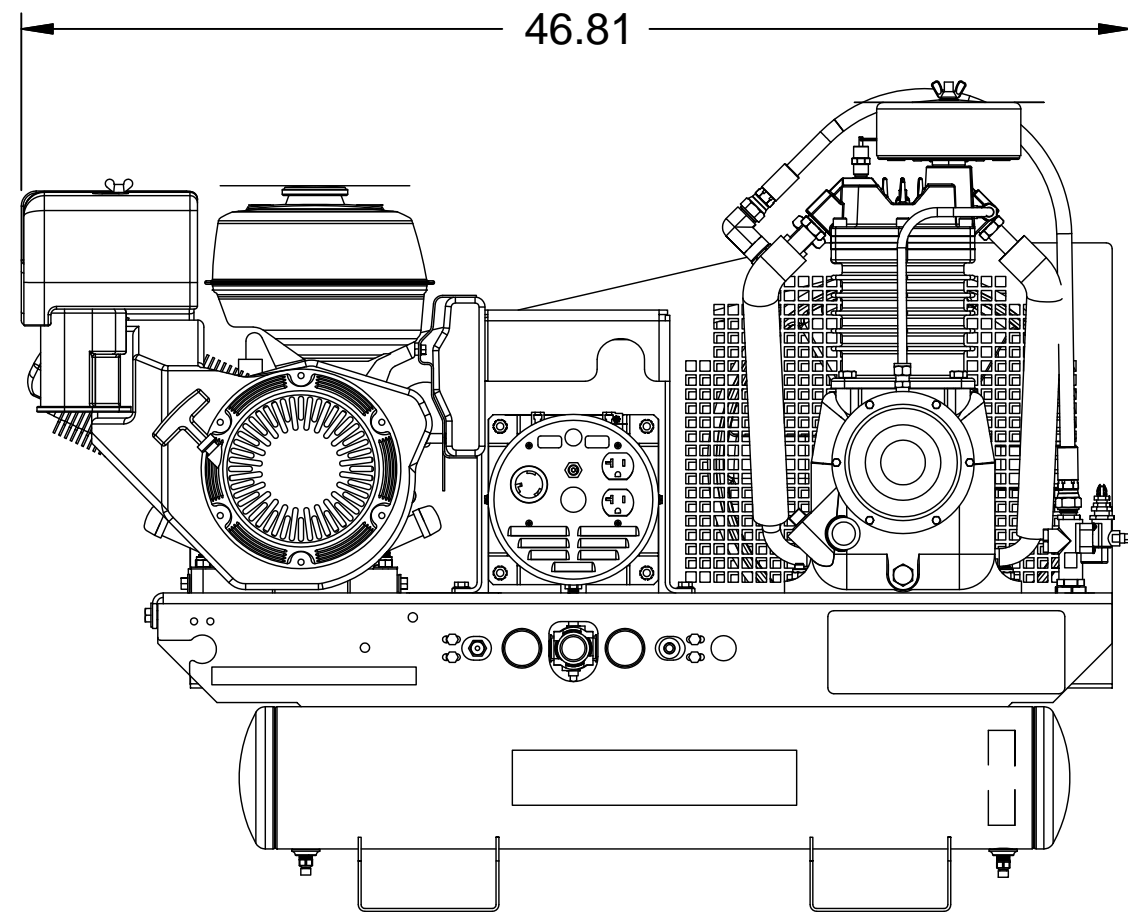
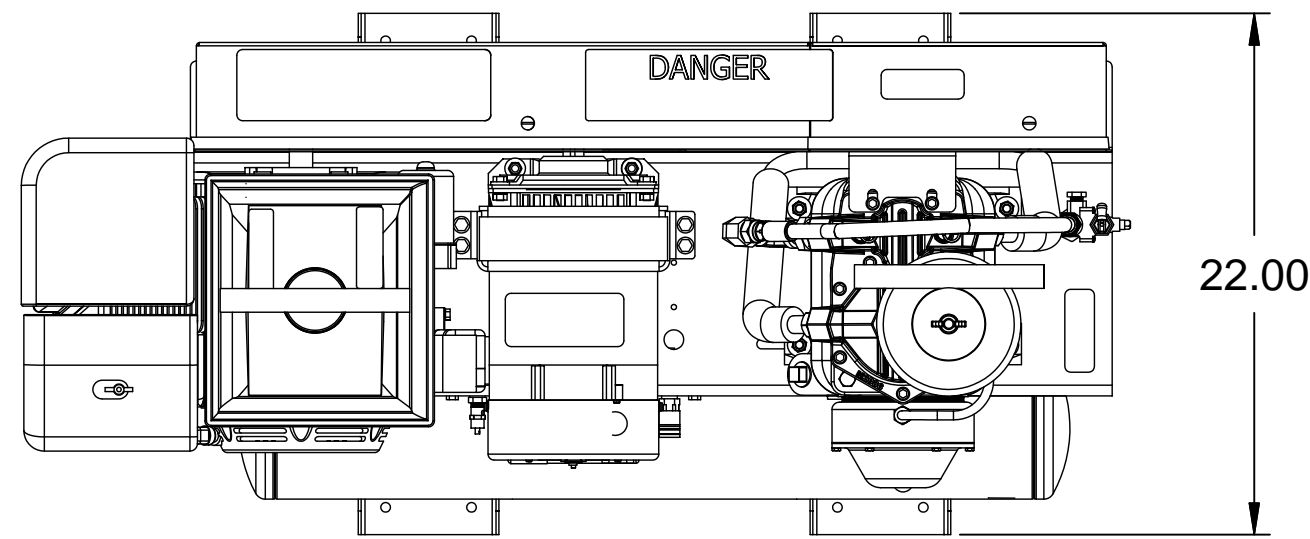

FINISH OF CHAMFERS & FILLETS TO CONFORM TO ROUGHEST ADJACENT AREA.
 SURFACE ROUGHNESS MAX. PER ASME B46.1 SPEC.
 FULL THD DEPTHS ARE MINIMUM.

UNLESS OTHERWISE SPECIFIED
 DIMENSIONS ARE IN INCHES
 TOL. ON DECIMALS: .X = ±.05
 TOL. ON DECIMALS: .XX = ±.02
 TOL. ON DECIMALS: .XXX AS SPECIFIED
 TOL. ON ANGLES: ± 0°-30'

THIRD ANGLE
 PROJECTION

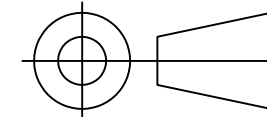

CONFIDENTIAL - THE INFORMATION CONTAINED IN THIS DOCUMENT IS THE PROPERTY OF GARDNER DENVER, INC. IT IS NOT FOR PUBLIC DISCLOSURE. POSSESSION OF THE INFORMATION DOES NOT CONVEY ANY RIGHT TO LOAN, SELL OR DISCLOSE THE INFORMATION. UNAUTHORIZED REPRODUCTION OR USE OF THE INFORMATION IS PROHIBITED. THIS DOCUMENT IS TO BE RETURNED TO GARDNER DENVER, INC. UPON THE COMPLETION OF THE PURPOSE FOR WHICH IT IS LOANED OR UPON REQUEST.

DIMENSIONING AND TOLERANCING PER ASME Y14.5-2009
 THREADS PER ASME B1.1 GAGING SYSTEM 21 U.O.S., ANSI B1.20.1 & B1.20.3

Gardner Denver

Gardner Denver Inc.
 Quincy, IL.

HEAT TREATMENT ENG. REF:

TITLE
COMP- GEN
 HGRV7-LPH-G

DWN BY	KWT	10/20/16	ENGINEERING APPROVAL	DWG NO.	REV
CK'D BY	RK	10/20/16	KT	CC1153480	A
SCALE			NTS		SHEET 1 of 1