

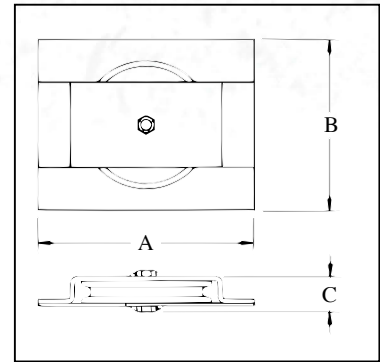

S-600S
Horizontal Lead Block

Horizontal Lead Blocks

- Available painted or galvanized.
- Fitted with steel sheaves.
- Self Lubricated Bronze Bushed.



S-600S / G-600S

Sheave Diameter (in.)	600 Series Stock No.		Resultant Working Load Limit (Tons)*	Wire Rope Size (in.)	Weight Each (lbs.)	Dimensions (in.)		
	S-600-S Painted	G-600-S Galv.				A	B	C
6	771999	772006	2	3/8	10.0	11.00	6.38	2.50
8	772015	772024	2-1/2	1/2	21.0	13.00	8.50	3.00
10	772033	772042	3	5/8	36.0	15.00	10.50	3.25
12	772051	772060	4	3/4	61.0	17.00	12.50	4.00
14	772079	772088	5	7/8	96.0	19.00	14.50	4.00

*Ultimate Load is 4 times the Resultant Working Load Limit.



G-601S
Vertical Lead Block

Vertical Lead Blocks

- Available painted or galvanized.
- Fitted with steel sheaves.
- Self Lubricated Bronze Bushed.

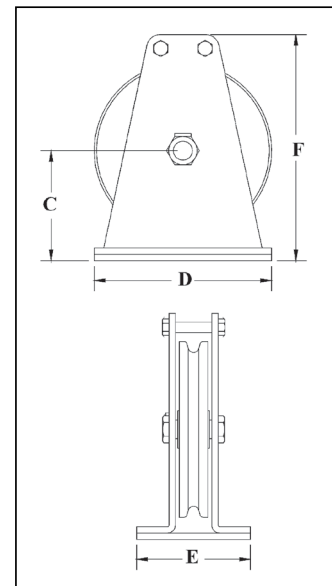

S-601S / G-601S

Sheave Diameter (in.)	601 Series Stock No.		Resultant Working Load Limit (Tons)*	Wire Rope Size (in.)	Weight Each (lbs.)	Dimensions (in.)			
	S-601-S Painted	G-601-S Galv.				C	D	E	F
6	772195	772202	2	3/8	10.00	3.50	6.00	5.50	7.00
8	772211	772220	2-1/2	1/2	24.50	4.88	8.00	6.75	9.75
10	772239	772248	3	5/8	31.50	6.38	10.00	7.75	11.75
12	772257	772266	4	3/4	60.00	7.25	12.00	6.00	15.25
14	2003424	2003425	5	7/8	98.00	8.75	14.00	9.00	18.00

*Ultimate Load is 4 times the Resultant Working Load Limit.