

# SPEED PRO

*Feel the difference*

## THE QUICKEST AND MOST ROBUST SERIES BY ZUMEX

The new Speed Pro range gives way to the reinvention of a generation of juicers that provide an even more efficient, safe and impeccable service both in the Retail sector and in Food Service.

**Offer the best freshly squeezed juice to your customers and bring them a Life Essence experience.**



### SPEED PRO

Model indicated for restaurants with a high juice demand due to its capacity and easy cleaning.

DIMENSIONS	593 x 574 x 989 mm / 23.35 x 22.6 x 38.94"
NET WEIGHT	64,7 kg   142,4 lb



### SPEED PRO SELF SERVICE

It is characterized by its autonomy and adaptability to restaurants, self services and hotel buffets.

DIMENSIONS	593 x 658 x 1050 mm / 23.35 x 25.91 x 41.34"
NET WEIGHT	72,2 kg   158,9 lb



### SPEED PRO SELF SERVICE PODIUM

Ideal for large Retail establishments due to its efficiency, simple operation and functionality.

DIMENSIONS	675 x 700 x 1765 mm / 26,57 x 27.56 x 69.49"
NET WEIGHT	118.1 kg   259.9 lb



### SPEED PRO TANK PODIUM

The perfect option for supermarkets, with its 5-litre (1,32 gal.) storage tank, which preserves freshly squeezed juice with the same quality.

DIMENSIONS	675 x 700 x 1765 mm / 26,57 x 27.56 x 69.49"
NET WEIGHT	116.7 kg   256.6 lb



### SPEED PRO COOLER PODIUM

Freshly squeezed and refrigerated juice, ready to drink. With temperature-controlled cooling device, 7-litre (1,85 gal.) tank and level detector.

DIMENSIONS	675 x 727 x 1850 mm / 26,57 x 28.62 x 72.83"
NET WEIGHT	128.3 kg   282.2 lb

## TECHNICAL CHARACTERISTICS

FRUITS PER MINUTE	40 f/min	VOLTAGE	220-240 V   50-60 Hz / 115 V   60 Hz
GALLONS PER MINUTE	0,66-1,99 gal/min	POWER	300 W (560 W COOLER) / 320 W (560 W COOLER)
FRUIT DIAMETER	65-85 mm (50-65 mm KIT D65)	CONSUMPTION	1.2 A (2.4 A) / 2.7 A (4.85 A COOLER)
HOPPER CAPACITY	20 kg   44 lb	SAFETY	Triple magnetic system



## PRODUCT HIGHLIGHTS



### New Feeder

4 kg more autonomy, up to 20kg.  
 Front door, 7cm easier.  
 Better orange rotation.  
 Broader feeder tube, up to 85mm diameter.  
 New Drain&Clean system, for better cleaning.

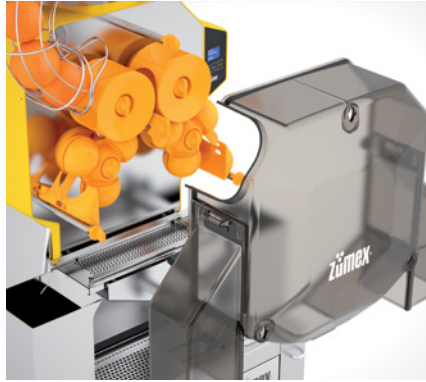

### Better juice extraction block

Redesign of feeder tube, with *Flap*.  
 New structure, with integrated electronics and invisible detectors.  
 New extraction cover with Click&Clean lugs, easy to dismantle.  
 New peel outlet system with automatic stop safety.

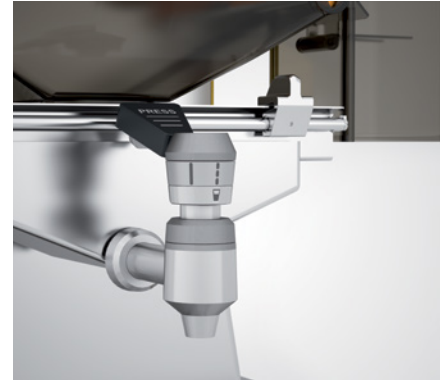

### 2Service Tap

New tap for a perfect service, more intuitive, functional and easier to clean.  
 Choose the best way to serve the juice, continuous or discontinuous.  
 Removable stainless steel bin "in just one click".



### PulpOut system

Slide and eliminate the pulp when you want.  
 Without affecting the performance.



### Intelligent Touch

Electronic devices for all models.  
 Choose the working mode: automatic or professional, the language or the number of oranges you want to squeeze.



### Waste management

9 kg more capacity, up to 52 kg of waste.  
 New trolley with wheels.  
 Security and mobility increased.

## ACCESSORIES



### D65 SQUEEZING KIT

This accessory permits squeezing fruit with **less than 65 mm diameter** such as small oranges, tangerines and limes.



### DYNAMIC CUTTING SYSTEM DCS

Squeezing **soft and very ripe citrus fruit** has a solution. There is no fruit that resists its dynamic blades.



### ZUMEX DISPLAY

For you to always have your **freshly squeezed juice bottles ready to take away**. Available in two sizes.



### SELF SERVICE TRAY KIT

Front support that is secured to the module, enabling the tray to be left on it **in self-service establishments**.

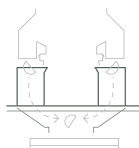

### COUNTER TOP KIT

Integrate bar counter waste management in the most practical and clean way with the **Counter Bar Kit**.



### BOTTLE RACK

Ideal for self-service applications, where there is a need to dispense bottles, jars or glasses. Includes three trays.  
**Zumex Pack, with 6 bottle formats** and customizable labels.