



SC-3 Features

The SC-3 features 3 stainless steel rollers, with the bottom roller being threaded to reduce splashing and guide the juice into your container. As you can see in the diagram (pictured bottom right), the SC-3 is extremely easy to disassemble. The rollers, along with the juice compartment, are removable for easy cleaning. Just wipe down the machine with a mild detergent and you are finished.

This machine also features an overload protection that will protect the motor in case the machine jams. In the event this does occur, the forward and reverse switch will unjam the unit. The featured gear box reduces the stress on the ½ HP motor, while adding more torque to process even the toughest cane.

Invest in Quality

The SC-3 Sugarcane Juicer is constructed with Stainless Steel that will hold up wonderfully in any busy environment. It utilizes a safety switch so that the customer cannot access the machine when the front guard is removed.

This machine offers a one year warranty, the longest warranty in the business because we stand behind our product 100%. Since 1982 we have been specializing in juicers and corers with the highest quality equipment available in the industry today and have juicers that will process anything from apples to wheatgrass. We take pride in our customer service and support.

Space Saving Specs

Inlet hole diameter: 2 ¼ inches
Output Speed: 15 rpm
Weight: 158 lbs.
Length: 24 inches
Width: 10 inches
Height: 21 inches
Motor: 110, ½ HP 7.5 amps

SC-3 Sugarcane Juicer

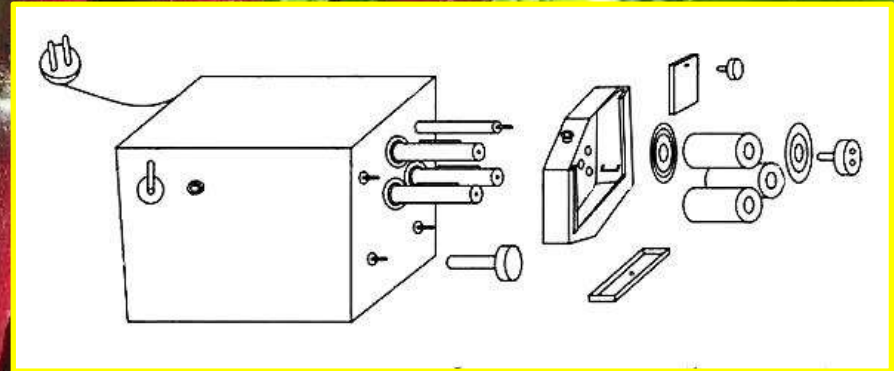

Simple to Disassemble

Numerous Profitable Serving Options



Serve Over Ice



Mix for Mojitos



Make Lemonade

~~MULLIGAN ASSOCIATES, INC.~~
~~286 Barbados Drive, Jupiter, FL 33458~~
~~(800) 627-2886 / (561) 745-8733~~
~~(561) 277-2466 Fax www.juicernet.com~~



10 Benefits of Drinking Sugarcane Juice

- ❖ It is a great preventive and healing source for sore throat, cold and flu.
- ❖ It has a low glycemic index which keeps the body healthy.
- ❖ This is one sweet drink diabetics can enjoy without fear because it has no simple sugars.
- ❖ Studies indicate that due to its alkaline nature, it has positive activity against prostate and breast cancer cells.
- ❖ It hydrates the body quickly to prolong heat and physical activity.
- ❖ It is an excellent substitute for soda.
- ❖ It refreshes and energizes the body instantly as it is rich in carbohydrates.
- ❖ Sugarcane strengthens the stomach, kidneys, heart, eyes, and brain.
- ❖ Liberal intake of sugarcane juice provides the body with necessary protein and other food elements.
- ❖ It keeps the urinary flow clear and helps the kidneys to perform their functions smoothly.