

KEYSTONE CLASSIC

#120 Yth Novice--#121 NP Novice--#123 13 & Under

Show Date: 05/24-26, 2019

www.HorseShowPatterns.com

www.HorseShowPatterns.com

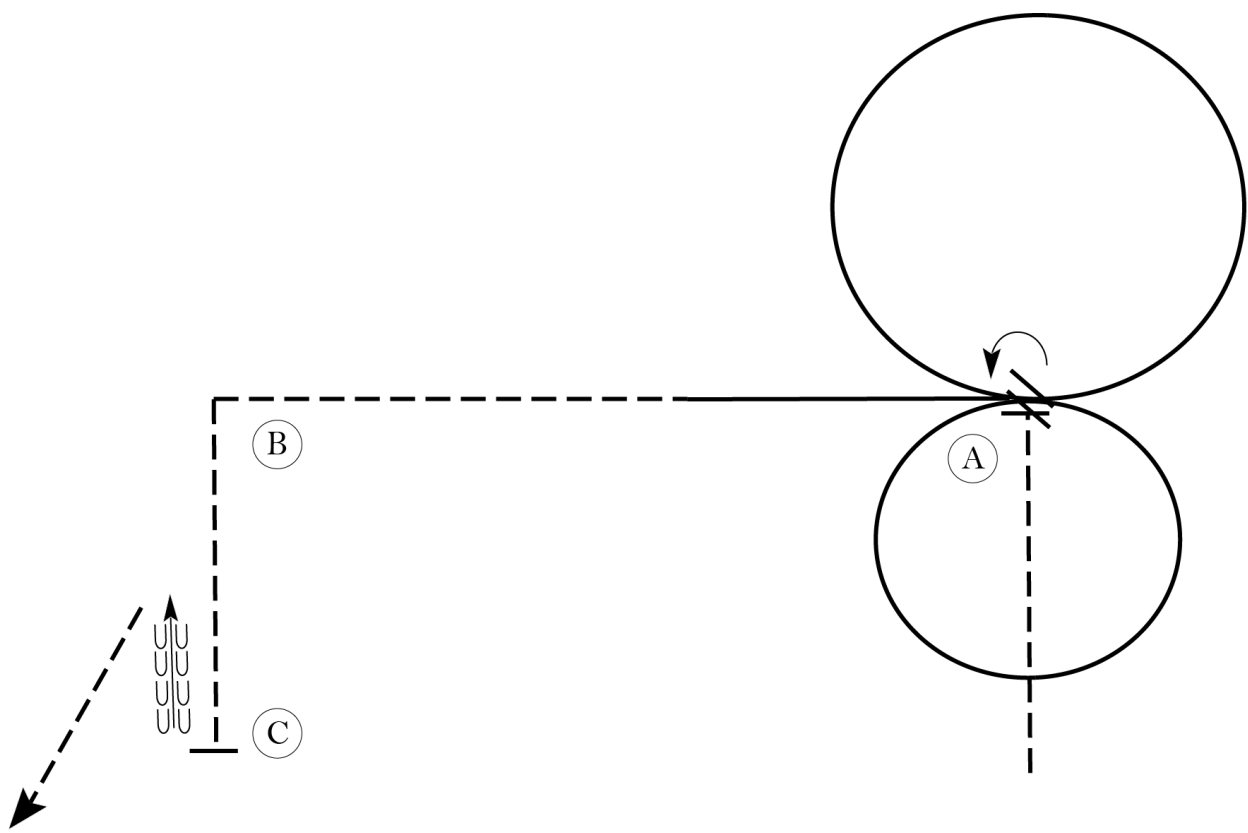

1. Trot on the left diagonal past A.
2. Stop and perform a 90 degree turn on the forehand to the left.
3. Canter a large circle to the right on the right lead.
4. Perform a simple lead change.
5. Canter a smaller circle to the left on the left lead and continue toward B.
6. Halfway to B, break to a sitting trot.
7. As you pass B, pick up the right diagonal and continue to C.
8. Stop at C and back one horse length and exit at a trot.

Follow the instructions of your ring steward.

Walk	-----
Trot	- - - - -
Extended Trot	-----
Canter	—————
Leg Yield	
Lead Change	↘ ↙
Back	← ← ← ← ←
Marker	⊙
Sidepass	← - - - - →
Hand Gallop	———

[HSE/2-78]

Pattern Provided by:
Your Judges

KEYSTONE CLASSIC

#124 35& Over--#125 14-18--#126 Non Pro--#127 Masters

Show Date: 05/24-26, 2019

w w w . H o r s e S h o w P a t t e r n s . c o m

w w w . H o r s e S h o w P a t t e r n s . c o m

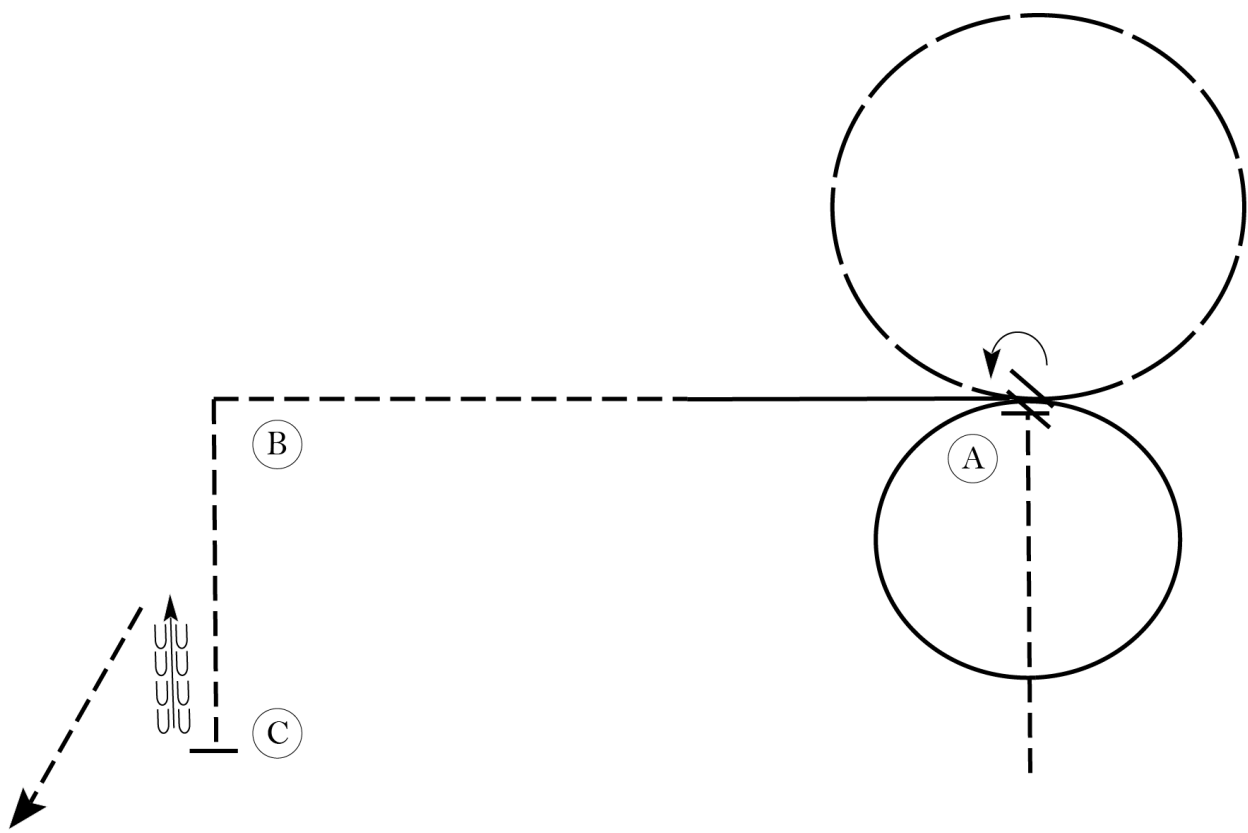

1. Trot on the left diagonal past A.
2. Stop and perform a 90 degree turn on the forehand to the left.
3. Hand gallop a circle to the right on the right lead.
4. Perform a simple lead change.
5. Canter a circle to the left on the left lead and continue toward B.
6. Halfway to B, break to a sitting trot.
7. As you approach B, drop your irons and continue to C.
8. Stop at C and pick up your irons.
9. Back one horse length and exit at a trot.

Follow the instructions of your ring steward.

Walk	-----
Trot	- - - - -
Extended Trot	-----
Canter	—————
Leg Yield	
Lead Change	↘ ↙
Back	← ← ← ← ←
Marker	⊙
Sidepass	← - - - - →
Hand Gallop	———

[HSE/3-78]

Pattern Provided by:
Your Judges

KEYSTONE CLASSIC

Saddle Seat Equitation Yth #96--Non Pro #97

Show Date: 05/24-26, 2019

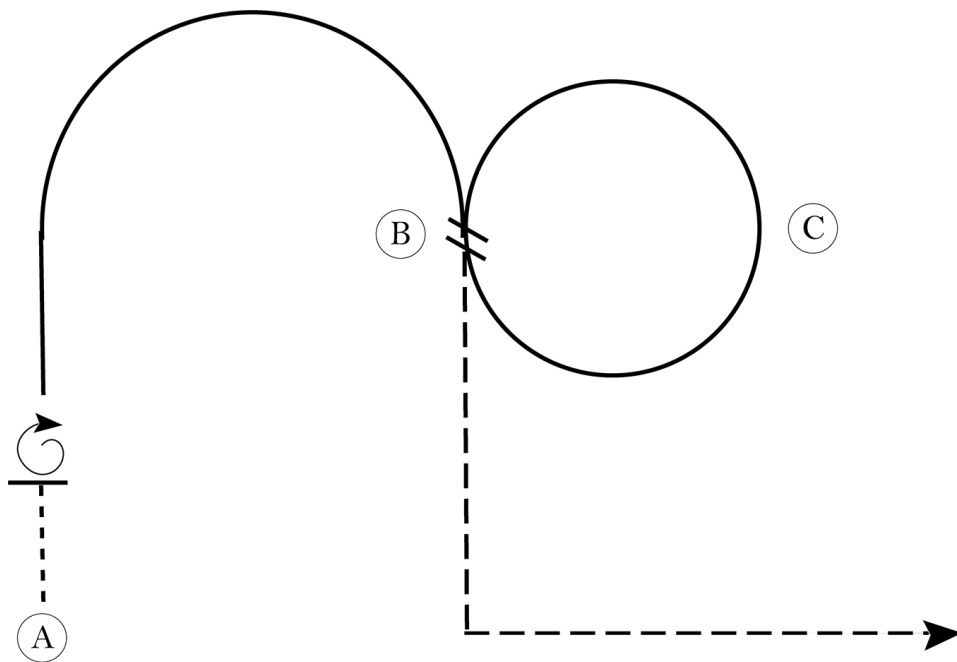

Be ready with your horse's tail to A.

1. Walk two horse lengths from A.
2. Stop and perform a 360 degree turn on the fore hand to the right.
3. Canter on the right lead in a half circle to B.
4. Perform a simple lead change at B.
5. Canter a circle to the left at B.
6. Rising trot on the left diagonal until even with A.
7. Turn left and change diagonals.
8. Rising trot on the right diagonal straight away from A.

Pattern is over once you have passed C at the trot.

Follow the directions of your ring steward.

Walk	-----
Trot	- - - - -
Extended Trot	— — — —
Canter	—————
Lead Change	↙ ↘
Back	← ← ← ← ←
Marker	(B)
Hand Gallop	—————

[HSE/3-46]

Pattern Provided by:

Your Judges

w w w . H o r s e S h o w P a t t e r n s . c o m

w w w . H o r s e S h o w P a t t e r n s . c o m

KEYSTONE CLASSIC

#118, #119, #122--Walk Trot Hunt Seat Equitation

Show Date: 05/24-26, 2019

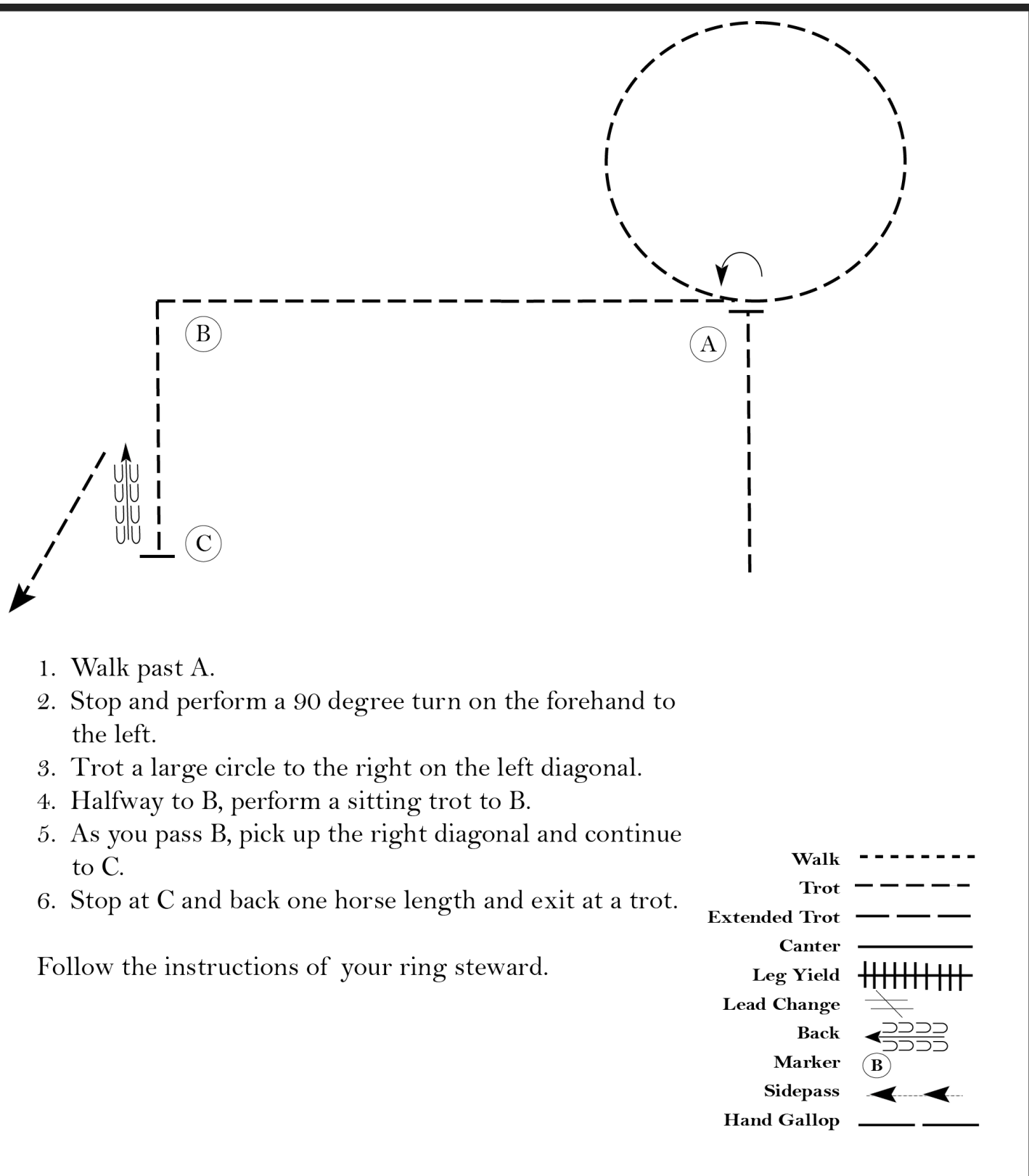

1. Walk past A.
2. Stop and perform a 90 degree turn on the forehand to the left.
3. Trot a large circle to the right on the left diagonal.
4. Halfway to B, perform a sitting trot to B.
5. As you pass B, pick up the right diagonal and continue to C.
6. Stop at C and back one horse length and exit at a trot.

Follow the instructions of your ring steward.

Walk
Trot	-----
Extended Trot	- - - - -
Canter	—————
Leg Yield	
Lead Change	↘↘↘
Back	←←←
Marker	(B)
Sidepass	←- - - -→
Hand Gallop	—————

[HSE/WT-78]

Pattern Provided by:

Your Judges

KEYSTONE CLASSIC

Hunter Hack Jr/Sr/Non Pro/Yth-#70,71,72,73

Show Date: 05/24-26, 2019

www.HorseShowPatterns.com

www.HorseShowPatterns.com

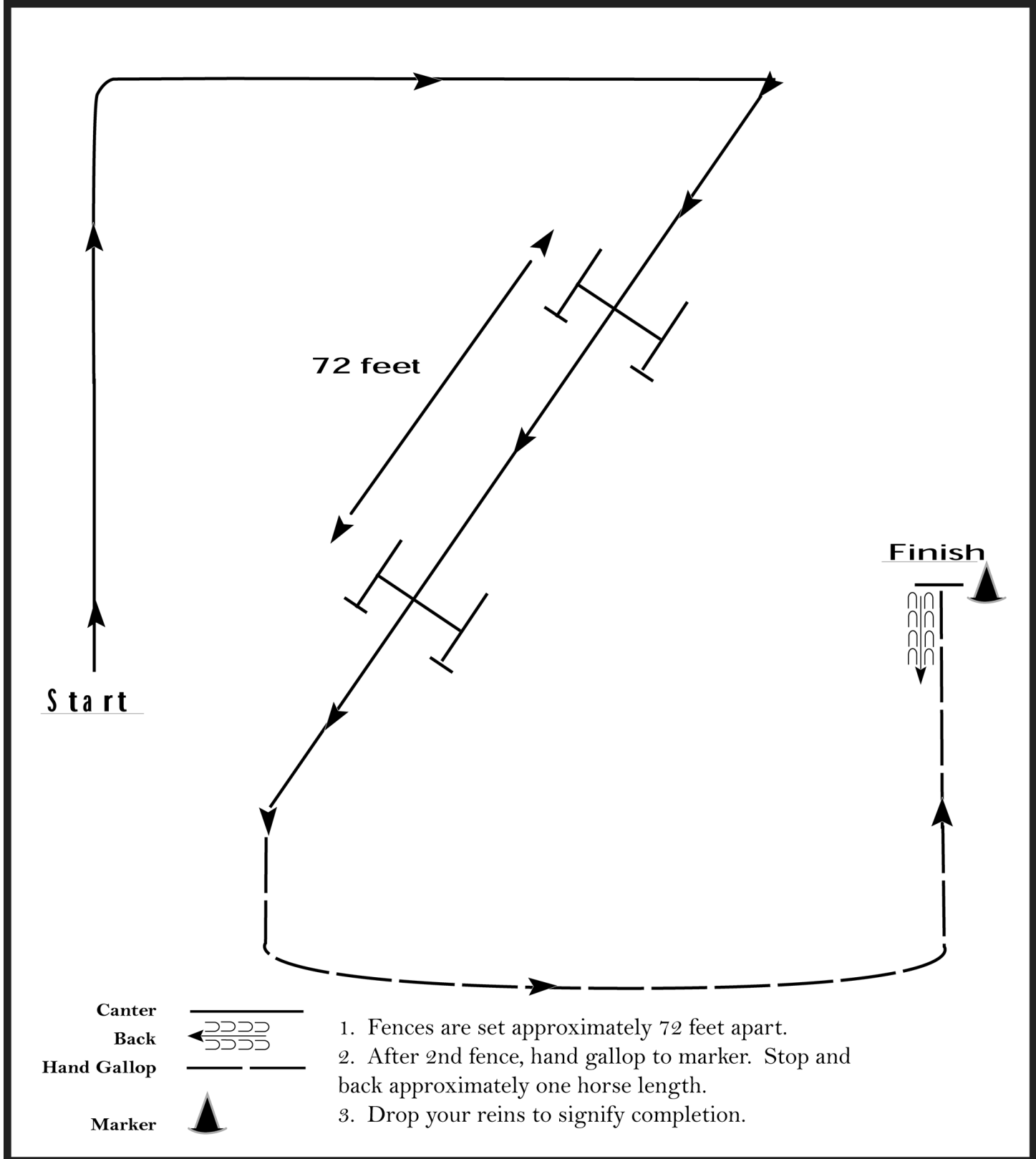

[HH/72-19]

Pattern Provided by:
Your Judges

KEYSTONE CLASSIC

#142 Novice Yth--#143 Novice NP--#144 13 & Under

Show Date: 05/24-26, 2019

w w w . H o r s e S h o w P a t t e r n s . c o m

w w w . H o r s e S h o w P a t t e r n s . c o m

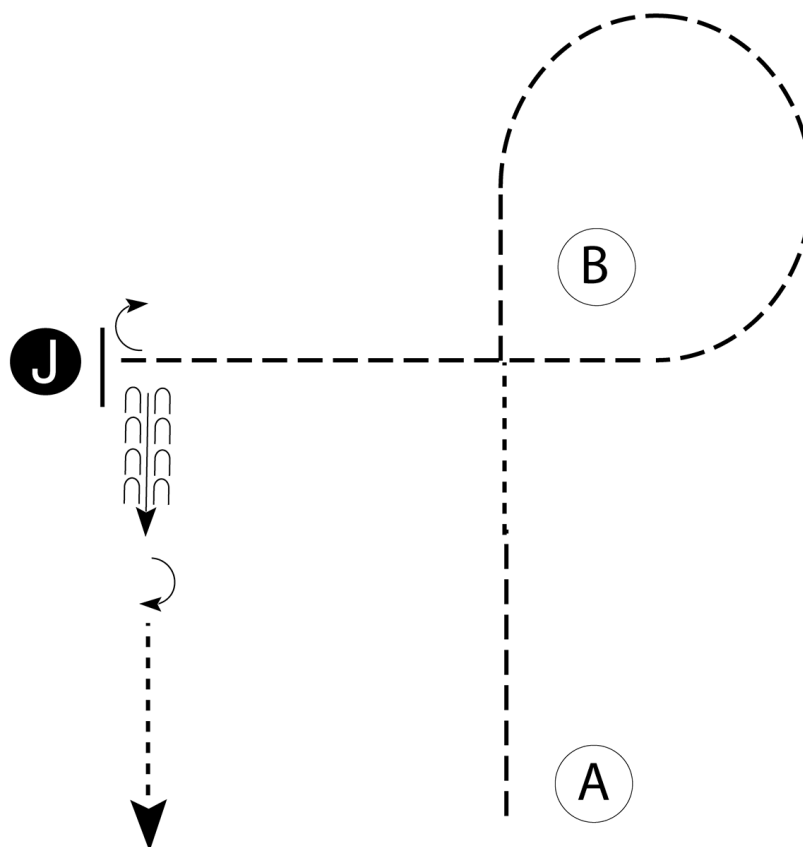

Be ready at A.

1. Trot halfway to B.
2. Walk two horse lengths.
3. Trot to and around B as shown.
4. Trot to the judge. Stop and set up for inspection.
5. When dismissed, perform a 90 degree turn and back approximately 2 horse lengths.
6. Perform a 180 degree turn and walk straight away.

Follow the instructions of your ring steward.

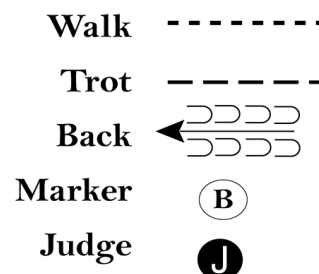

[S/2-78]

Pattern Provided by:
Your Judges

KEYSTONE CLASSIC

#145 35 & Over--#146 14-18--#147 Non Pro--#148 Masters

Show Date: 05/24-26, 2019

w w w . H o r s e S h o w P a t t e r n s . c o m

w w w . H o r s e S h o w P a t t e r n s . c o m

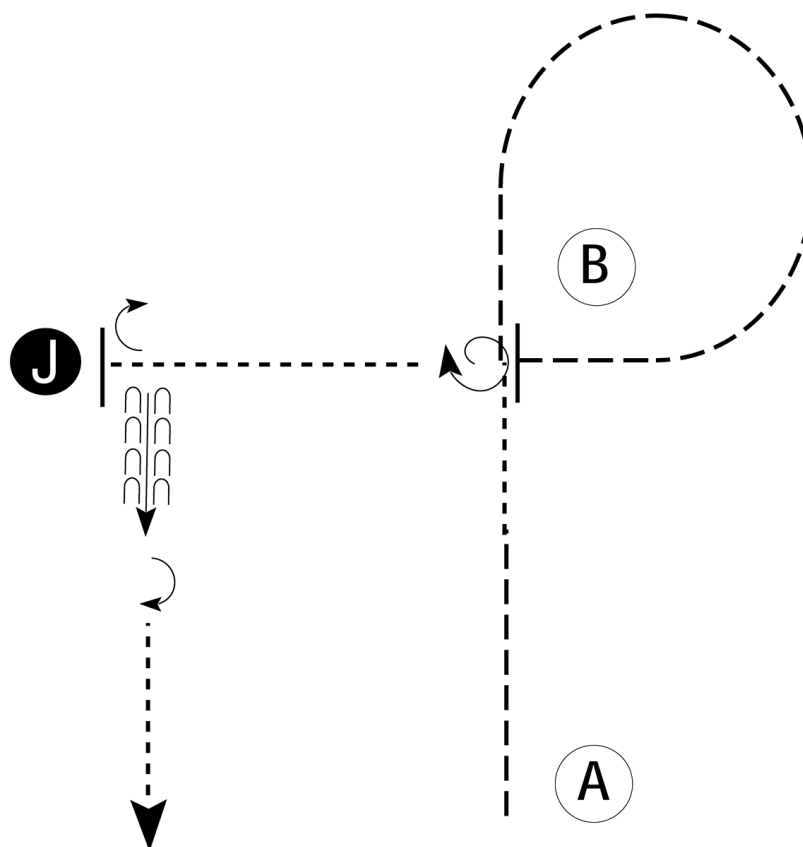

Be ready at A.

1. Trot halfway to B.
2. Walk two horse lengths.
3. Trot to and around B as shown.
4. Trot past B and stop. Perform a 360 degree turn.
5. Walk to judge and set up for inspection.
6. When dismissed, perform a 90 degree turn and back approximately 2 horse lengths.
7. Perform a 180 degree turn and walk straight away.

Follow the instructions of your ring steward.

Walk	-----
Trot	- - - - -
Back	← 
Marker	ⓑ
Judge	ⓐ

[S/3-78]

Pattern Provided by:
Your Judges

KEYSTONE CLASSIC

#168 Yth Novice--#169 NP Novice--#171 13 & Under

Show Date: 05/24-26, 2019

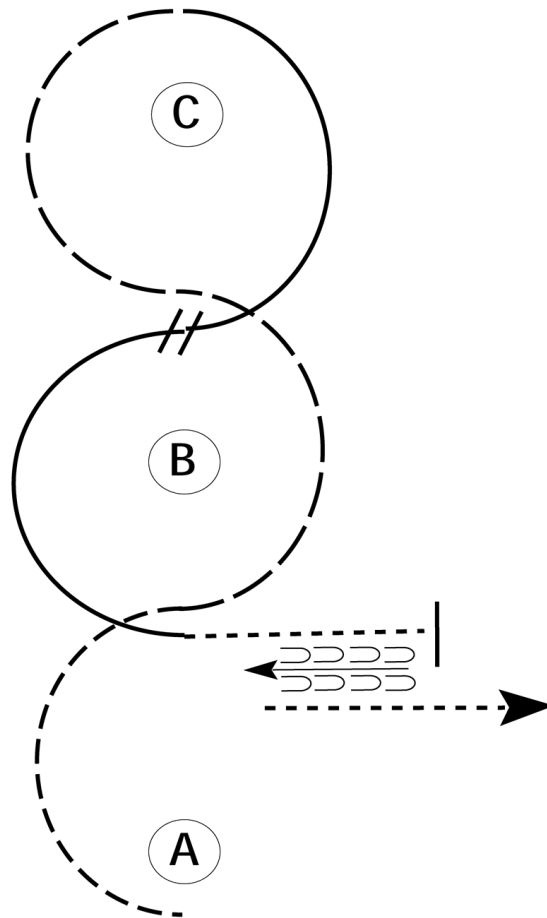

Be ready at A.

1. Jog in a half circle until between A and B.
2. Extend the jog around B and C as shown.
3. Lope on the right lead in a half circle until between C and B.
4. Perform a simple lead change.
5. Lope on the left lead in a half circle until between B and A.
6. Walk approximately 2 horse lengths.
7. Stop and back approximately one horse length then walk straight away.

Walk
Jog	-----
Extended Jog	-----
Lope	—————
Lead Change	///
Back	←←← ←←←
Marker	ⓑ

Follow the instructions of your ring steward.

[WH/2-85]

Pattern Provided by:

Your Judges

KEYSTONE CLASSIC

#149 Yth Bareback--#150 Non Pro Bareback

Show Date: 05/24-26, 2019

www.HorseShowPatterns.com

www.HorseShowPatterns.com

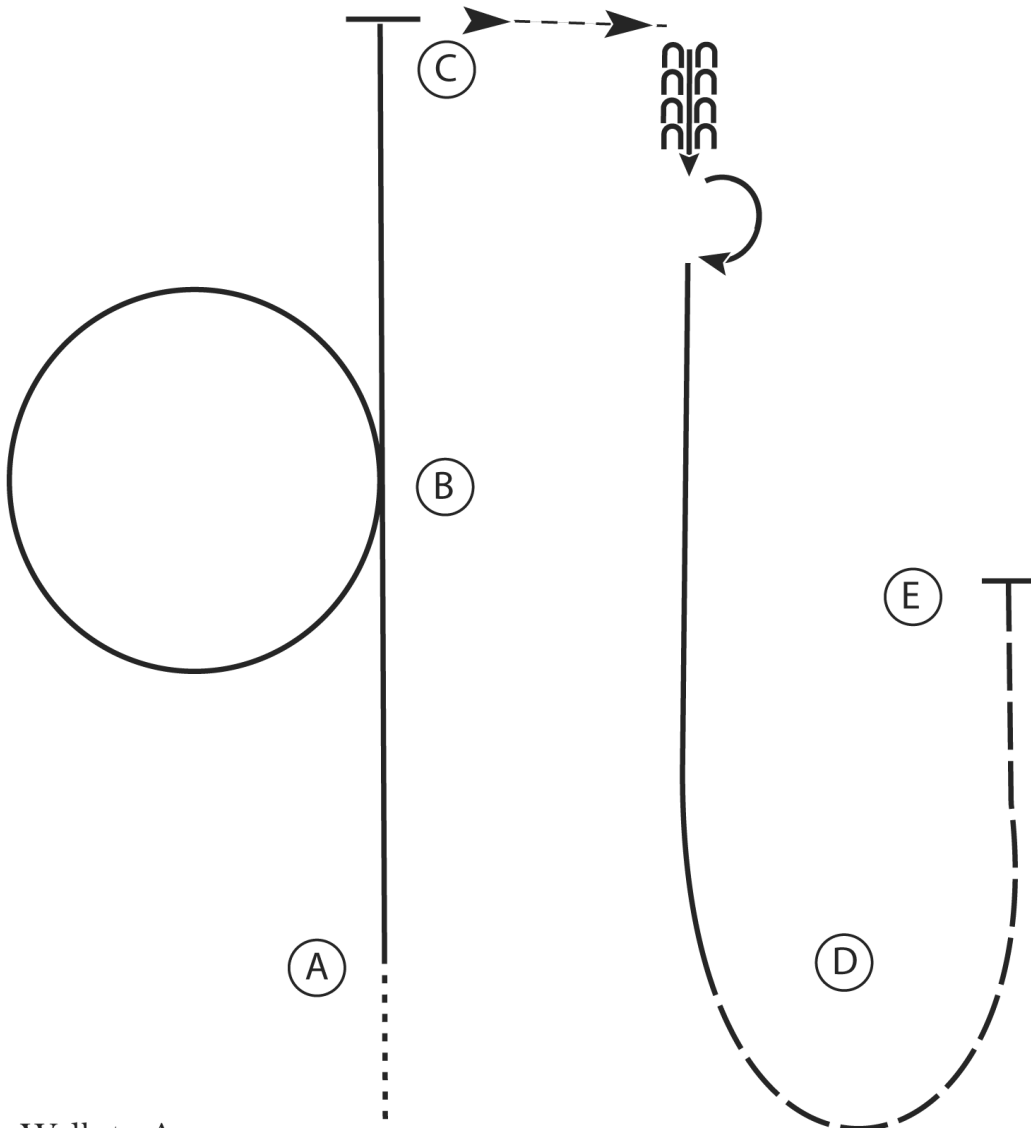

1. Walk to A
2. At A lope on the left lead to B
3. At B lope a circle to the left and continue to C
4. Stop past C and sidepass right
5. Back 3 steps
6. Perform a 180 degree turn to the right on the hindquarters
7. Lope on the right lead to D
8. At D extend the jog around D
9. Stop at E

Walk
Jog	-----
Extended Jog	-----
Lope	—————
Leg Yield	
Lead Change	⚡
Back	←←← →→→
Marker	(B)
Sidepass	←←←

[WH/3-26]

Pattern Provided by:

Your Judges

KEYSTONE CLASSIC

#172 35 & Over--#173 14-18--#174 Non Pro--#175 Masters

Show Date: 05/24-26, 2019

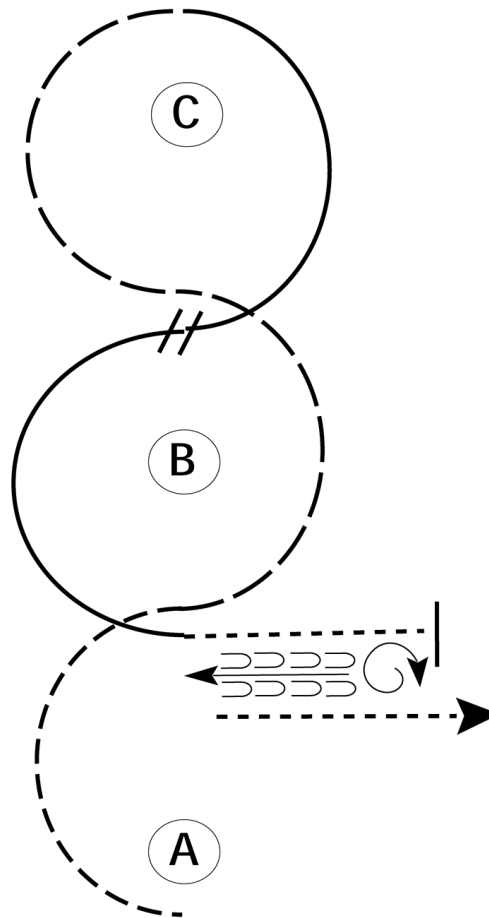

Be ready at A.

1. Jog in a half circle until between A and B.
2. Extend the jog around B and C as shown.
3. Lope on the right lead in a half circle until between C and B.
4. Perform a simple lead change.
5. Lope on the left lead in a half circle until between B and A.
6. Walk approximately 2 horse lengths.
7. Stop and perform a full turn to the right.
8. Back approximately one horse length and walk straight away.

Walk -----

Jog - - - - -

Extended Jog - - - - -

Lope _____

Lead Change

Back

Marker

Follow the instructions of your ring steward.

[WH/3-85]

Pattern Provided by:

Your Judges

KEYSTONE CLASSIC

#166 Yth W/T--#167 NP W/T--#170 Yth W/T 11-18

Show Date: 05/24-26, 2019

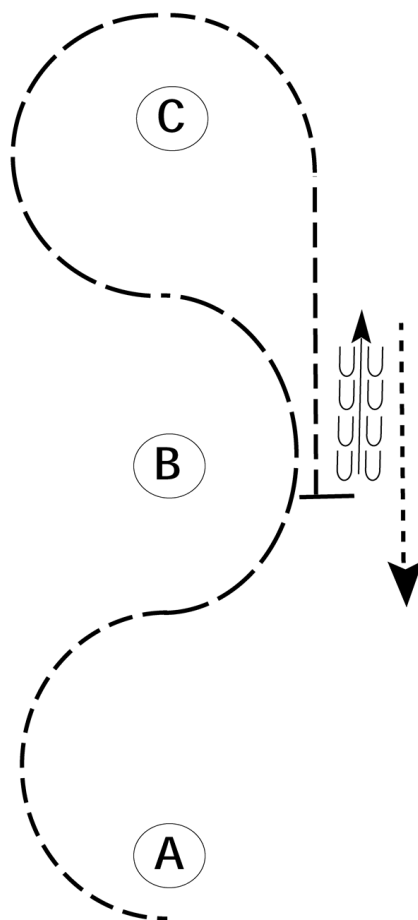

Be ready at A.

1. Jog in a half circle until between A and B.
2. Extend the jog around B and C as shown.
3. Slow to a jog and jog until even with B.
4. Stop and back approximately one horse length.
5. Walk straight away.

Follow the instructions of your ring steward.

Walk	-----
Jog	- - - - -
Extended Jog	— — — —
Lope	
Lead Change	— / —
Back	← — — — —
Marker	ⓑ

[WH/WT-85]

Pattern Provided by:
Your Judges

w w w . H o r s e S h o w P a t t e r n s . c o m

w w w . H o r s e S h o w P a t t e r n s . c o m

KEYSTONE CLASSIC

#141 Walk Trot Showmanship 10 & Under

Show Date: 05/24-26, 2019

w w w . H o r s e S h o w P a t t e r n s . c o m

w w w . H o r s e S h o w P a t t e r n s . c o m

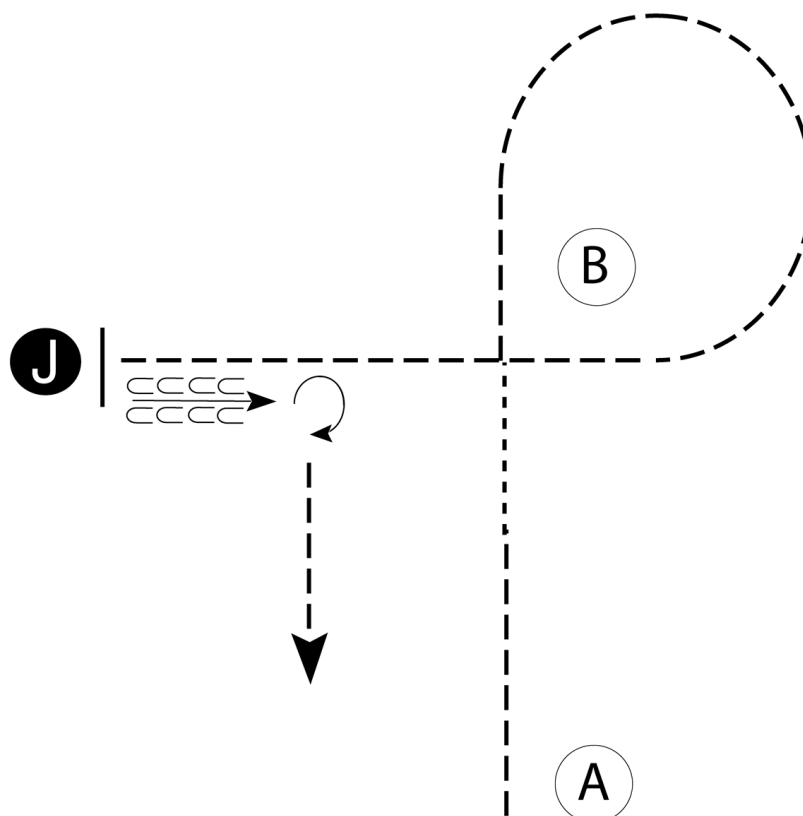

Be ready at A.

1. Trot halfway to B.
2. Walk two horse lengths.
3. Trot to and around B as shown.
4. Trot to the judge. Stop and set up for inspection.
5. When dismissed, back approximately 2 horse lengths.
6. Perform a 270 degree turn and trot straight away.

Follow the instructions of your ring steward.

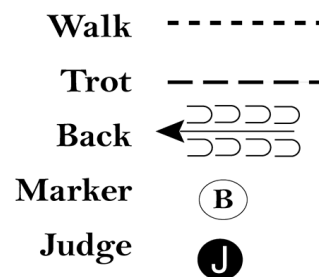

[S/1-78]

Pattern Provided by:

Your Judges

KEYSTONE CLASSIC

English Showmanship--13 & Under #94/14-18 #95

Show Date: 05/24-26, 2019

w w w . H o r s e S h o w P a t t e r n s . c o m

w w w . H o r s e S h o w P a t t e r n s . c o m

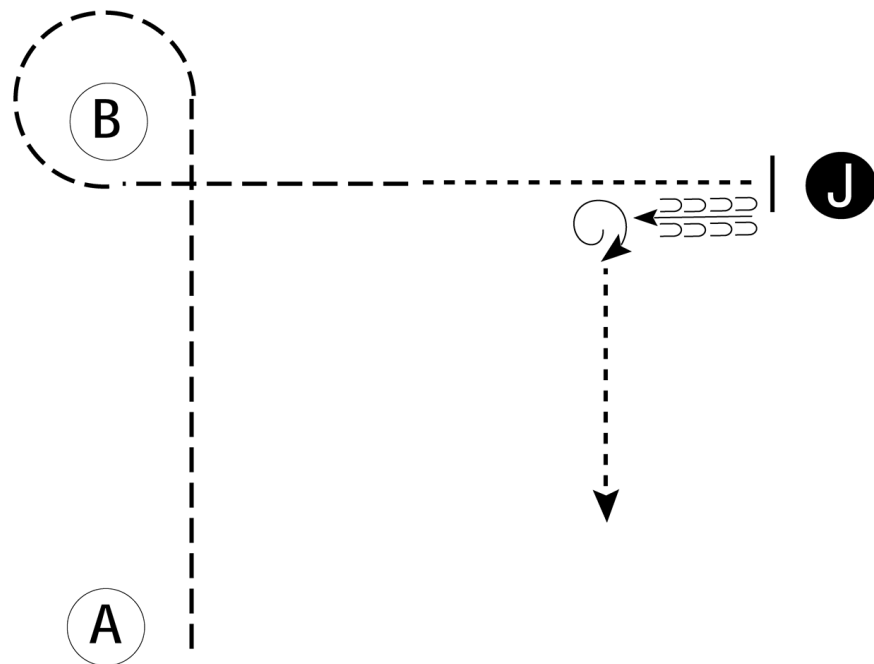

Be ready at A.

1. Trot from A to B.
2. Trot a tight circle around B.
3. Continue to trot halfway to judge.
4. Break to a walk and walk to judge.
5. Stop and set up for inspection.
6. When dismissed, back approximately one horse length.
7. Perform a 1 1/4 turn and walk away.

Follow the directions of your ring steward.

Walk	-----
Trot	- - - - -
Back	← 
Marker	ⓑ
Judge	ⓐ

[S/3-56]

Pattern Provided by:
Your Judges

KEYSTONE CLASSIC

#140 Youth/Non Pro Showmanship Sweepstakes

Show Date: 05/24-26, 2019

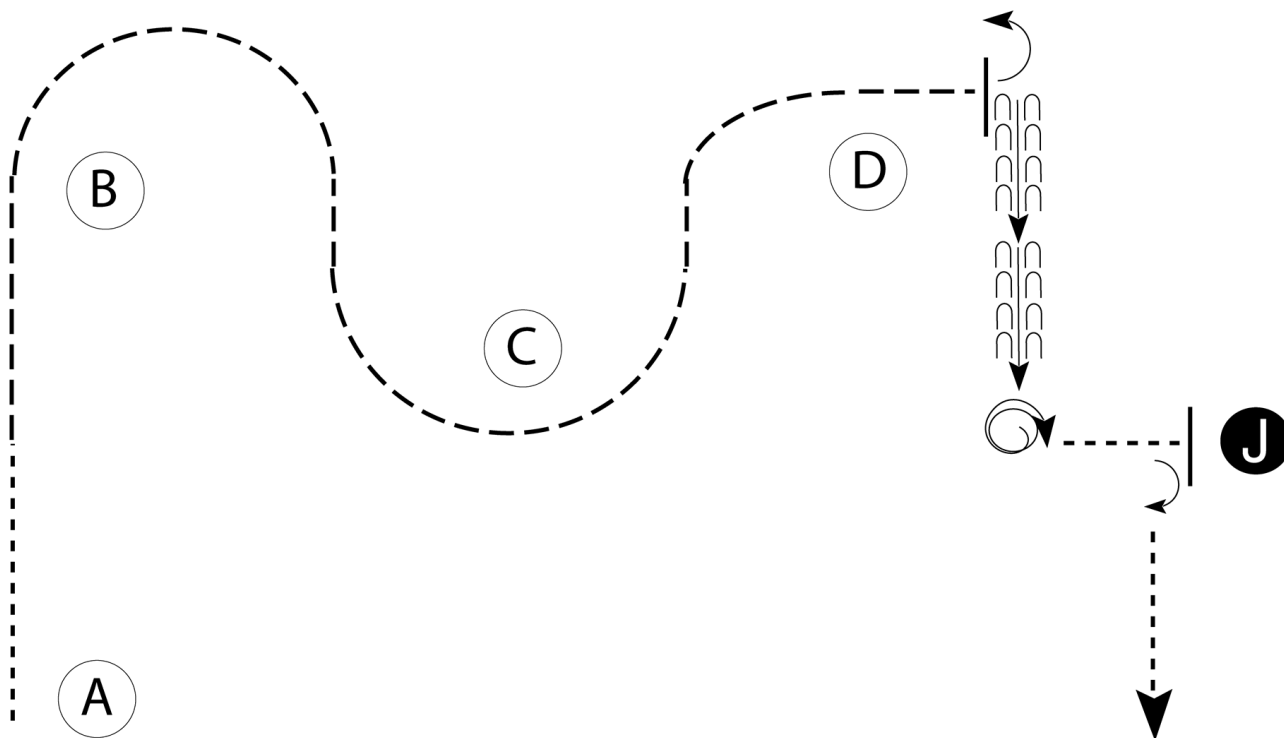

Be ready at A.

1. Walk from A halfway to B.
2. Trot around markers B, C and past D.
3. Stop. Perform a 1/4 pull turn.
4. Back.
5. Perform 2 1/4 turns and walk to the judge.
6. Stop and set up for inspection.
7. When dismissed, perform a 1/4 turn and walk away.

Follow the instructions of your ring steward.

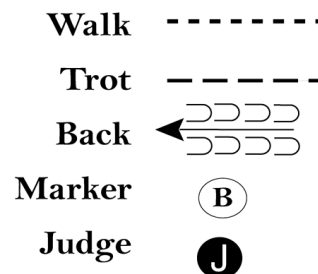

[S/3-74]

Pattern Provided by:

Your Judges

KEYSTONE CLASSIC

#63, #64, #65, #66, #67, #68, #69--Hunter Classes

Show Date: 05/24-26, 2019

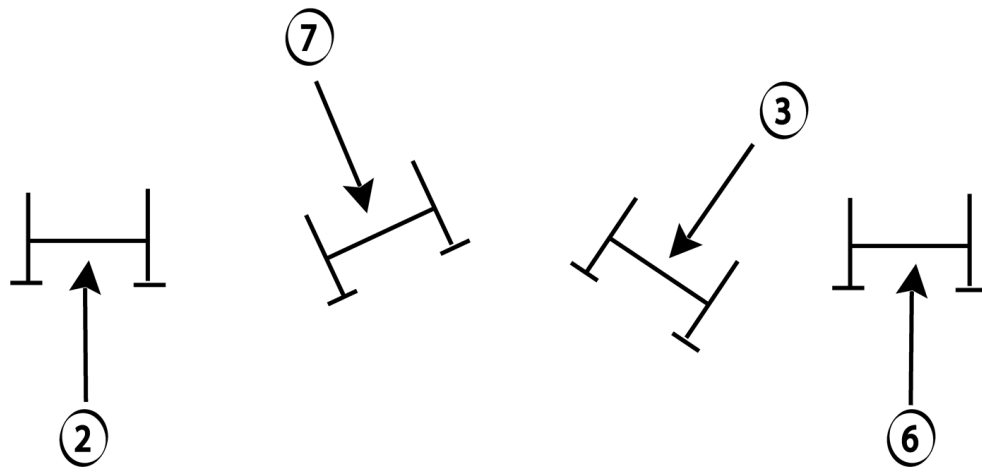

60 Feet

60 Feet

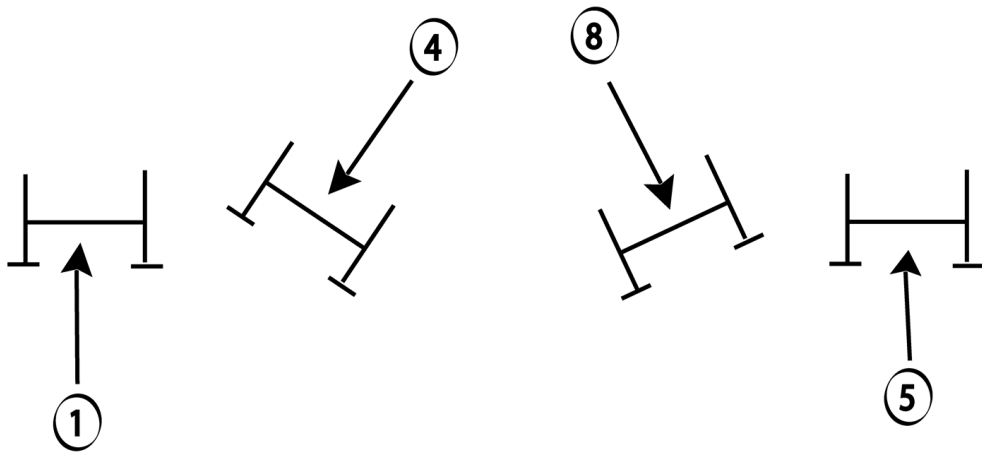

Pattern Provided by:
Your Judges

[WH/O-2]

w w w . H o r s e S h o w P a t t e r n s . c o m

w w w . H o r s e S h o w P a t t e r n s . c o m

KEYSTONE CLASSIC

Ranch Riding Yth #59-N/P #60-Open #61

Show Date: 05/24-26, 2019

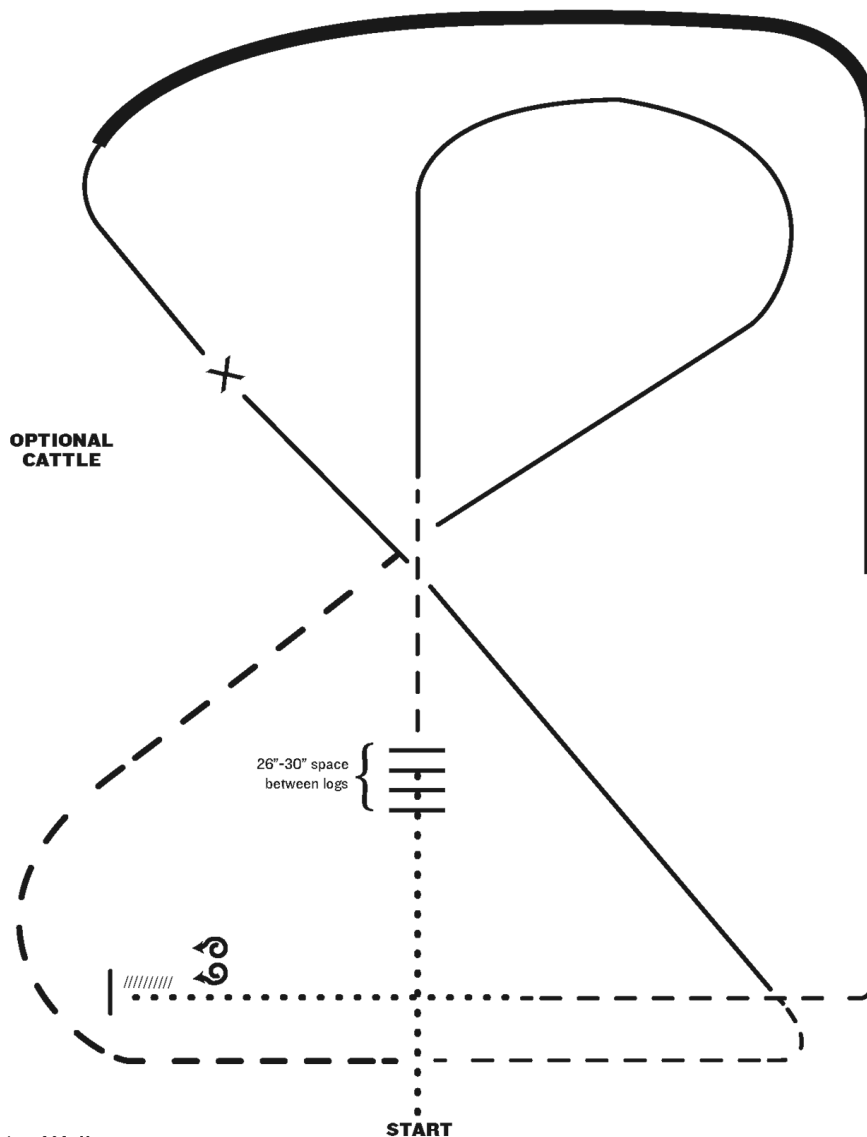

1. Walk
2. Walk over logs
3. Trot
4. Lope right lead
5. Extended trot
6. Trot
7. Lope left lead
8. Change leads (simple or flying)
9. Right lead, extended lope
10. Collect Lope
11. Trot
12. Walk
13. Stop and back
14. 360 degree turn each direction (either direction 1st) (L-R or R-L)

Note: The drawn description of this pattern is only intended for the general depiction of the pattern. Exhibitors should utilize the arena space to best exhibit their horses.

[RR/AQHA-5]

Pattern Provided by:
Your Judges

KEYSTONE CLASSIC

Reining--Yth #12--N/P #13--Open #14

Show Date: 05/24-26, 2019

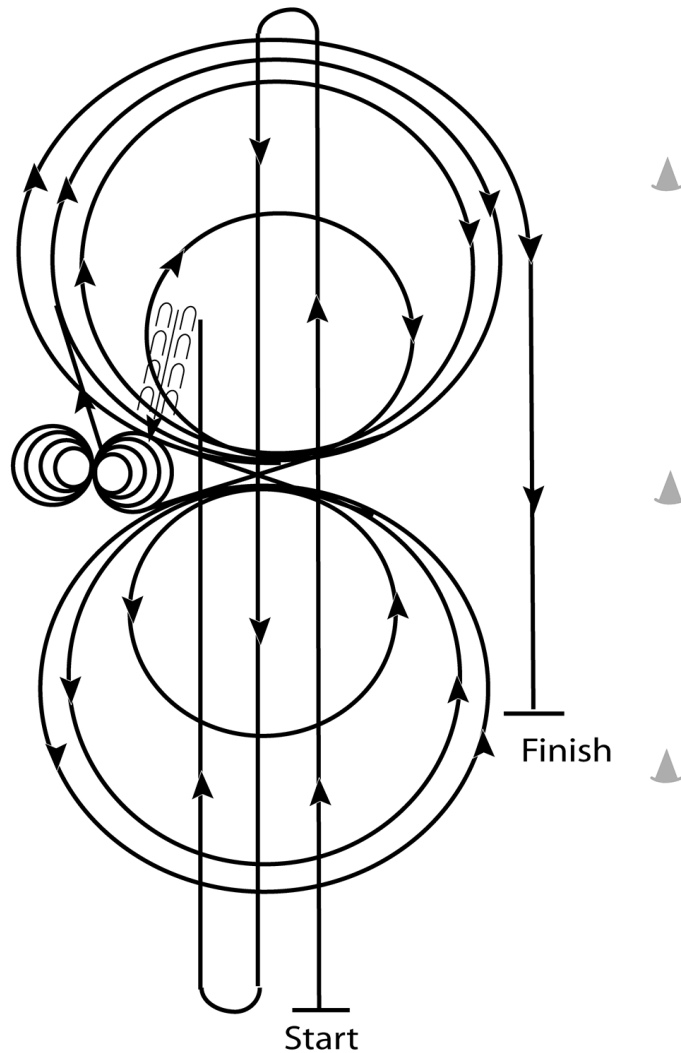

1. Run at speed to the far end of the arena past the end marker and do a left rollback – no hesitation.
2. Run to the opposite end of the arena past the end marker and do a right rollback – no hesitation.
3. Run past the center marker and do a sliding stop. Back up to the center of the arena at least ten feet (3m). Hesitate.
4. Complete four spins to the right.
5. Complete four and one-quarter spins to the left so that horse is facing left wall or fence. Hesitate.
6. Beginning on the right lead, complete three circles to the right: the first two circles large and fast; the third circle small and slow. Change leads at the center of the arena.
7. Complete three circles to the left: the first two circles large and fast; the third circle small and slow. Change leads at the center of the arena.
8. Begin a large fast circle to the right but do not close this circle. Run straight down the right side of the arena past the center marker and do a sliding stop at least twenty feet (6.09m) from the wall or fence. Hesitate to demonstrate completion of the pattern.
Rider may drop bridle to the designated judge.

[R/AQHAP-7]

Pattern Provided by:

Your Judges

KEYSTONE CLASSIC

Green Western Riding #128

Show Date: 05/24-26, 2019

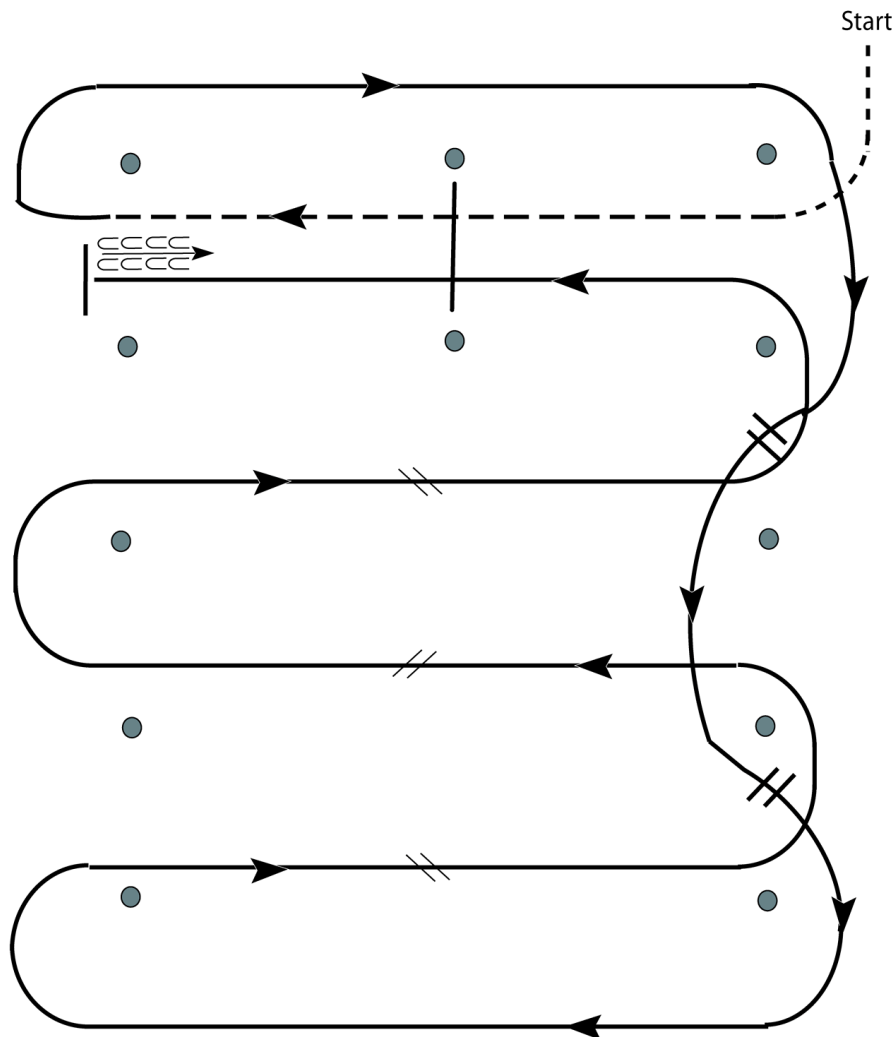

1. Walk, transition to jog, jog over log.
2. Transition to right lead and lope around end.
3. First line change.
4. Second line change. Lope around end of arena.
5. First crossing change.
6. Second crossing change.
7. Third crossing change.
8. Lope over log.
9. Lope, stop and back.

[WR/GP-4]

Pattern Provided by:

Your Judges

KEYSTONE CLASSIC

Western Riding--Yth #129--N/P #130--Open #131

Show Date: 05/24-26, 2019

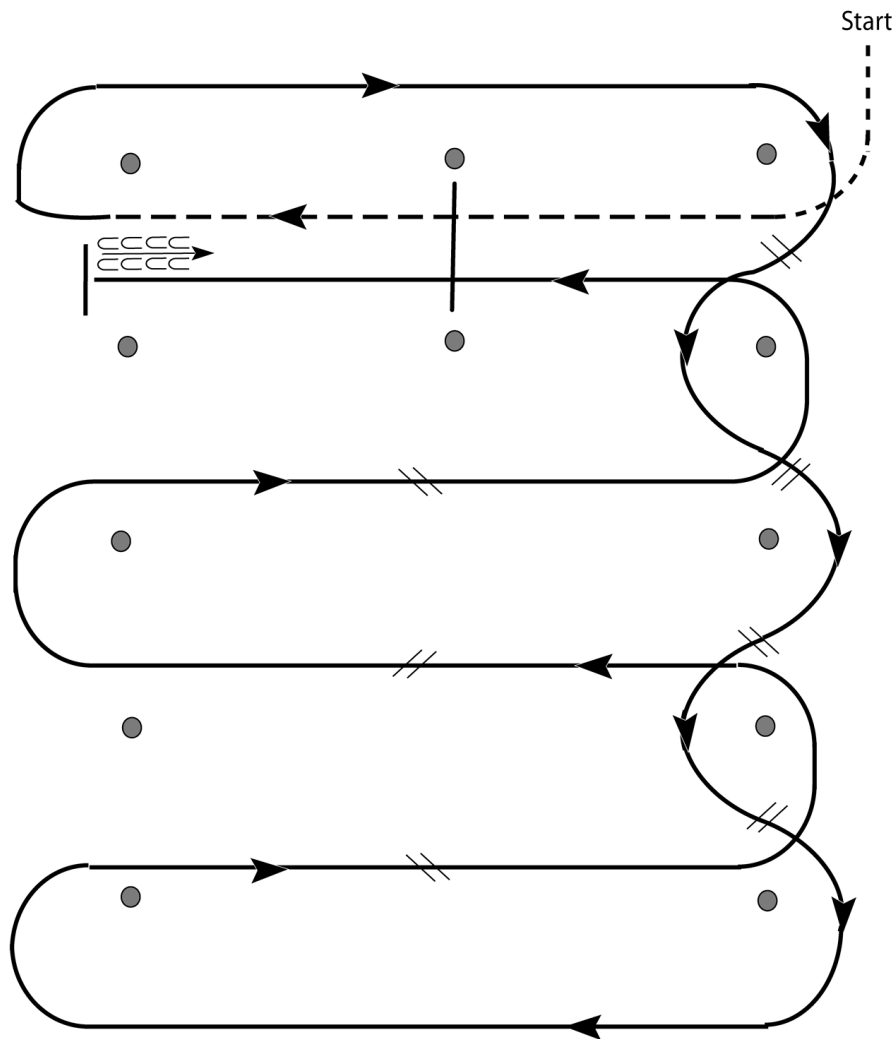

1. Walk, transition to jog, jog over log.
2. Transition to right.
3. First line change.
4. Second line change.
5. Third line change.
6. Fourth line change.
7. First crossing change.
8. Second crossing change.
9. Third crossing change.
10. Lope over log.
11. Lope, stop and back.

[WR/OP-4]

Pattern Provided by:

Your Judges