

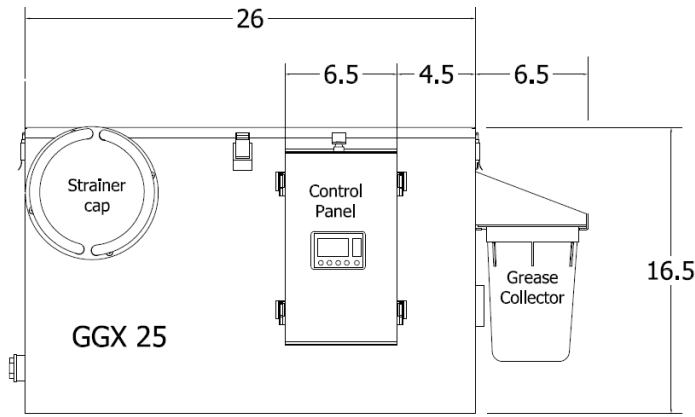

GGX25 Grease Guardian Standard Specification

25 GPM - 50 Pounds
Grease Capacity



FRONT VIEW

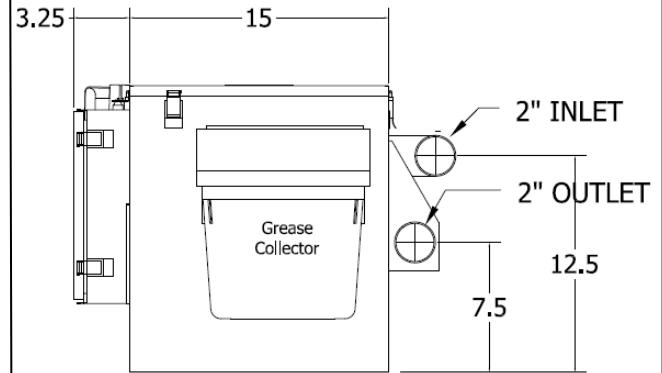

SIDE VIEW

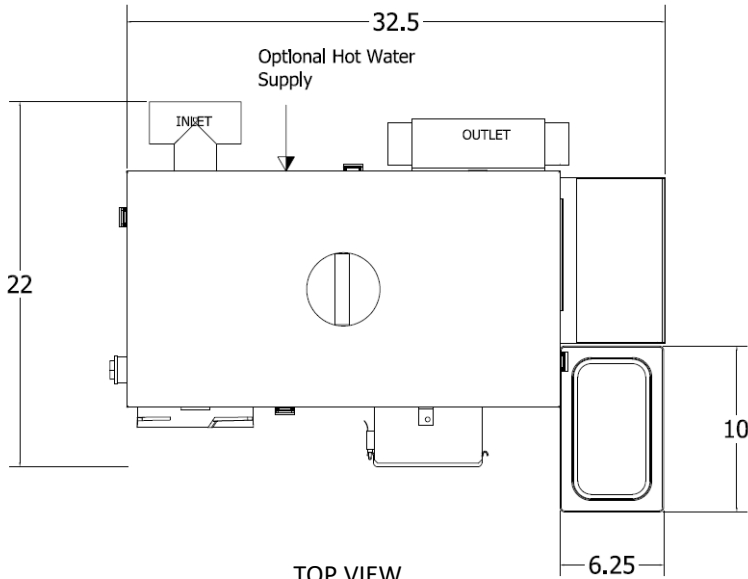

TOP VIEW

GREASE GUARDIAN STANDARD FEATURES

- 3 Year Warranty
- 16 gauge stainless steel welded tank
- Fully sealed air tight lid
- Universal flow direction
- PLC/HMI automatic controller
- Energy saving mode
- Long life skimming blade
- Dry basket solids strainer
- 1.1 gallon grease collection container
- 1/2" hot water connection
- Concealed plumbing & electrical connections
- No internal tank user maintenance required
- Integral flow control
- Integral gas trap
- Grease Guardian World asset management



TECHNICAL DATA

Weight	102 pounds
Material	16 gauge stainless steel
Interior	Stainless steel & acetyl components
Maximum flow rate	25 gallons per minute
Total grease retention capacity	50+ pounds
Solids strainer capacity	6.6 pounds
Skimming rate / Low cycle	11 pounds per cycle
Skimming rate / High cycle	22 pounds per cycle
Available cycles / day	4
Programming / Control	Programmable Logic Controller
Electrical load	110VAC 630watts 5.73A



**GREASE GUARDIAN
GGX25**

KEY INSTALLATION NOTES

- Allow for the minimum clearances shown
- Allow 35" x 24" for tank and container base
- Allow adequate clearance for solids strainer
- Allow adequate space for grease container
- Inlet port is uni-directional (single)
- Outlet port is uni-directional (single)
- Keep outlet piping at 1/8" per foot or greater
- Use rubber pipe connections provided
- Only switch on after filling with water
- Refer to full manual for full instructions

PRE-START UP CHECKS

- Ensure unit is positioned on a level surface and is plumbed securely
- Ensure electrical outlet is fitted with dedicated ground fault circuit breaker
- Ensure unit is filled with water to the correct level
- Ensure strainer basket is fully closed
- Set PLC date and time as detailed in the manual
- Ensure the grease container is empty and secured in place

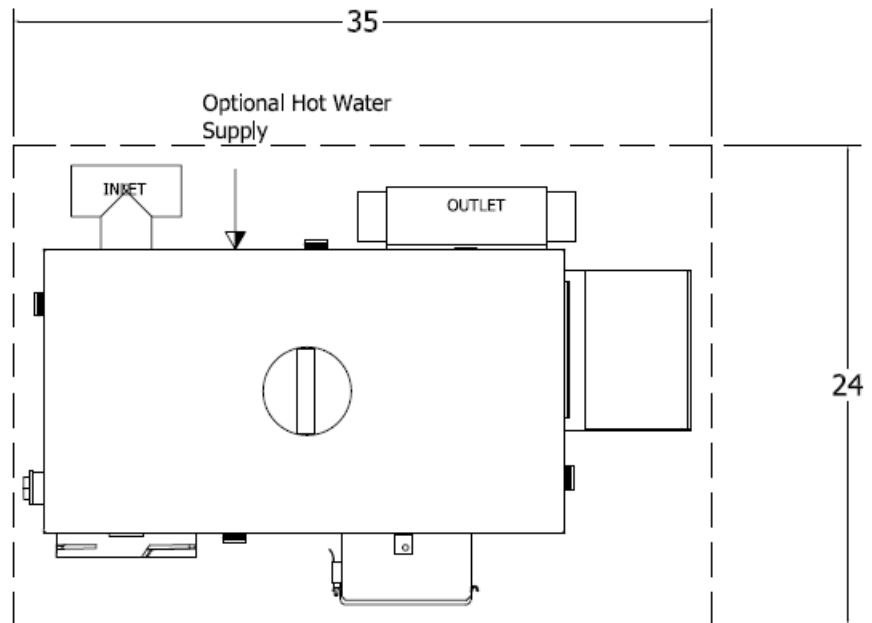

MINIMUM FLOOR SPACE RECOMMENDATION

SPECIFICATION

Install _____ Grease Guardian Model GGX25, self-cleaning automatic grease removal unit. 16 gauge fully welded 304 stainless steel tank stainless steel internal baffle plate, fully sealed air tight stainless steel lid and robust stainless steel clamps, above water heavy duty stainless steel dry solids strainer basket, uni-directional inlet and outlet flow connections, with easy fit pipe couplings, concealed plumbing and electrical connections, 25 gallon per minute flowrate, 50+ pounds grease retention capacity, and skimming rate of 11/22 pounds per low/high cycle. The GGX25 is supplied with a stainless steel rotating skimming drum, integral gas trap, integral flow control, totally enclosed geared drive unit, 600 watt immersion heater with self-regulating safety control, programmable controller and interface with energy saving mode. The GGX25 is suitable for floor or shelf mounting arrangements. The GGX25 is electrically tested and approved to UL499 and CSA C22-2 88-1952 standards. 3 year warranty is standard.

Electrical Details

GGX25 110VAC 630 Watts 5.73A



Grease Guardian World is an interactive online register for all Grease Guardian products, uploaded and managed by Grease Guardian, distributors and end users.