

merchant MEDIA

User Guide 3.5" Keypad



CRANE®

3330 Dixie Narco Blvd • Williston SC 29853
www.cranems.com

Rev 2 1/2013

P/N CR0018847

Table of Contents

| | |
|-------------------------------------|----------|
| • Compliance Requirements | Page 3 |
| • Specifications | Page 5 |
| • Cautions & Definitions | Page 8 |
| • Inspection & Installation | Page 10 |
| • Initial Start up | Page 18 |
| • Service Mode Security | Page 23 |
| • How do I Access the Service Modes | Page 25 |
| • Service Mode Chart | Page 29 |
| • Schematics | Page 223 |
| • Software License Information | Page 226 |

Compliance Requirements

- **LOCATION OF MANUFACTURER:**
- All machines are built at the Crane Merchandising Systems manufacturing facility, located at 3330 Dixie Narco Blvd, Williston SC 29853, USA

- **DATE OF MANUFACTURE:**
- Date of manufacture can be determined by viewing the Manufacturing Date on the Serial Number decal, located on the top left rear corner of the back of the machine cabinet.

- **PERMITTED & NON PERMITTED USES OF THIS MACHINE**
 - This machine is designed to dispense pre-packaged food, candy, beverage, snack and similar products. Use of unwrapped food products is not permitted.
 - It is not permitted to use this machine outdoors, or in an environment where flammable or explosive vapors are present.
 - This machine is not designed, nor should it be used to dispense flammable or explosive items, nor any other item that could not be safely dispensed by dropping it into the delivery bin.

Compliance Requirements

All models are built to meet or exceed all applicable standards, including but not limited to:

- International (CE) Approvals to meet or exceed the below listed standards:
 - 83/23/EEC (93/68/EEC) Low Voltage Directive.
 - 89/336/EEC EMC Directive
 - EN 60335-1 Safety of household and similar electrical appliances.
 - DIN VDE 0700 T224 Safety requirements for Automatic and coin-operated machines and control devices for commercial use.
 - EN 55022 Class B Limits and methods of measurements of Radio interference characteristics of information technology equipment.
 - IEC 801-1 Electromagnetic compatibility for industrial-processing measurement and control. Part 1: General.
 - IEC 801-2 Part 2; Electrostatic discharge requirements for industrial process measurement control equipment.
 - IEC 801-3 Part 3; Radiated electromagnetic field requirements.
 - IEC 801-4 Part 4; Electrically fast transient.
 - IEC 801-5 Draft; Surge immunity requirement.
 - IEC 801-6 Draft; Immunity to conducted disturbances induced by radio frequency.
 - EN 50082-1 Generic immunity requirements; Residential, Commercial, Light industry.
- Machines built for the US Market meet or exceed the requirements for UL751 for ambient machines, and UL541 for chilled machines, and have also been reviewed and passed the NAMA Construction Standard, and are permitted to bear the NAMA Mark.

Specifications

- **NOISE LEVEL**
 - This machine operates at less than 70 db (A).
- **ACCEPTABLE AMBIENT OPERATING TEMPERATURE RANGE.**
 - This equipment was designed and tested to work properly in a temperature range of 10°C to 32°C (50°F to 90°F) in still air (45% Relative Humidity, non-condensing). Usage at ambient conditions outside the range of the testing may cause unacceptable appearance or performance.
- **STORAGE CONDITIONS**
 - The machine capable of being stored in a temperature range of -18°C to 68°C (0°F to 155°F). Storage temperatures below 0°C (32°F) require that the operator to take the required precautions to insure that any water is removed from the condensate system prior to storage.
- **INDOOR USE ONLY**
 - This machine is designed to be used in an Indoor Setting only. Indoor Setting is defined as inside a structure constructed with four walls and a roof, and sufficiently protected from ambient conditions and not subjected to the effects of weathering. Any other usage is in direct violation of these instructions, and will void the warranty of the machine and its components.

Specifications

| Specifications | Model 186 4 Wide Ambient | Model 187 6 Wide Ambient |
|-------------------------------|-----------------------------|-----------------------------|
| Height (in) | 72 | 72 |
| Width (in) | 32.8 | 43.75 |
| Depth (in) | 38.5 | 38.5 |
| Floor Space (sq ft) | 8.8 | 11.7 |
| Container size (cu ft) | 52.8 | 70.2 |
| Shipping Weight (lbs) | 510 | 610 |
| Voltage | 120V | 120V |
| Running Amperes | 3A | 3A |
| Refrigeration/Charge | NA | NA |
| Compressor Size (hp) | | |
| High Side Test Pressure (psi) | | |
| Low Side Test Pressure (psi) | | |

Specifications

| Specifications | Model 471 4 Wide Combo | Model 472 6 Wide Combo |
|-------------------------------|---------------------------|---------------------------|
| Height (in) | 72 | 72 |
| Width (in) | 32.8 | 45.5 |
| Depth (in) | 32.5 | 32.5 |
| Floor Space (sq ft) | 7.4 | 10.3 |
| Container size (cu ft) | 44.4 | 61.6 |
| Shipping Weight (lbs) | 529 | 729 |
| Voltage | 120V | 120V |
| Running Amperes | 8A | 8A |
| Refrigerant/Charge | 7.5 oz. R134A | 9.8 oz R134A |
| Compressor Size (hp) | 1/3 | Super 1/3 |
| High Side Test Pressure (psi) | 250 | 250 |
| Low Side Test Pressure (psi) | 105 | 105 |

Cautions & Definitions

It is critical that all cautions and warnings be reviewed and complied with during the unpacking, installation, operation, and repair of this machine



CAUTION: This machine is designed for indoor usage only. Any other usage will void the Manufacturer's Warranty



CAUTION: Any procedure marked with the symbol at left requires that the Machine have the power applied and a shock hazard exists. Only a trained and authorized person should attempt these repairs.



CAUTION: It is important that this machine is hooked up to the proper voltage and polarity for your country. Use a Voltmeter to verify voltage and polarity. Should the reading be any different than a normal reading or if you are unsure of what the reading should be, contact an electrician.



CAUTION: Different countries may have unique plug arrangements. Ensure that the machine is properly grounded before operating. .



CAUTION: The power cord for all machines are of a type X attachment. If the power cord is damaged, it should be replaced by a trained service agent, or a similarly qualified person in order to avoid a hazard.

Cautions & Definitions



CAUTION: The machine is a heavy item. Ensure that sufficient personnel are available for lifting and transporting the machine. Use proper lifting procedures and equipment.



CAUTION: This machine is designed to dispense pre-packaged food, candy, beverage, snack and similar products. Use of unwrapped food products is in direct contradiction to these cautions.



CAUTION: If this machine is used to dispense perishable food, and local health codes require that the machine monitor the cabinet temperature, and prevent vending when the temperature exceeds a defined limit for a period of time, then the Health Code function must be enabled for those affected selections – see Health Code Setup



CAUTION: The electronic system components in this machine utilize static sensitive components. Precautions for handling sensitive devices should be observed when handling these items.

Inspection and Unpacking

The Merchant Media is assembled and packed so that a minimum amount of time is necessary for preparation to install it on location. The following steps are recommended to insure correct unpacking.

- **Shipping Damage:** Thoroughly inspect the exterior of the carton for damage which may have occurred during shipment. Report any damage to delivering carrier and follow their instructions.
- Remove the remainder of the packing material. On machines shipped with the lock in place, the keys are taped inside the coin return.
- Removal of shipping boards: There are 2 methods available for removal of the shipping boards on the bottom of the machine:
 - **a) Using a motorized lifting device (i.e. a forklift) raise the machine to a comfortable working height and remove the leg levelers with the use of a socket or wrench (1 5/16”). Do this on one side at a time. After the front and rear leg levelers are removed, the shipping board can then be removed. Replace the leg levelers in the legs of the machine before lowering to the ground**
 - **b) When using a pallet jack (non-motorized) insert a pry bar into the slit on the front and rear of the wooden boards, and twist the bar to force the boards to split apart, and remove from the machine. Screw the leg levelers all the way in before lowering the machine to the ground.**
- **NOTE: On the machine, the weight concentration is toward the back of the cabinet. Trucking and lifting should be done from the back. CAUTION should be taken when trucking from side.**
- On machines with lock in place, first unlock and turn handle to open door. When no lock is furnished, remove clip and turn handle. Swing door to its full open position.
- Remove all additional packing material from the machine.

Unpacking ADA Bin

Attention!

To avoid damage to the ADA delivery bin mechanism, remove the SHIPPING BOLTS from the bin sides prior to operating the ADA delivery bin!!!

The Shipping Bolts must be installed any time the machine is moved or transported. Failure to do so could result in damage to the delivery bin



View of shipping bolt
(2 shipped per bin)

Shipping Location

(two bolts – back of bin sides on left and right)



Bin tilted out to access bolts

Moving the merchandiser through a narrow doorway

NOTE

If necessary, this merchandiser can be moved through an opening as narrow as 30 inches by removing panels at the top and bottom of the cabinet.

Step 1- Remove the top Panel

1. Remove the screws that secure each end of the panel to the cabinet.
2. Pull the panel forward to remove it from the merchandiser.

Note: This only applies to an Ambient machines.

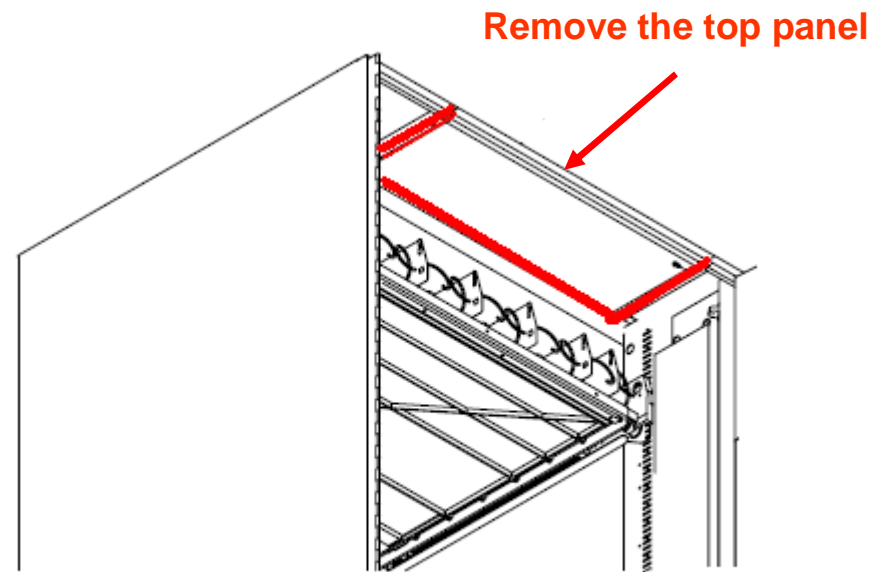

Figure 1

Moving the merchandiser through a narrow doorway

Step 2

REMOVING THE LOWER PANEL AND DELIVERY BIN

(Refer to Figures 2 and 3 at right.)

1. Open the slide-out monetary and the glass door. Locate the silver tab of the delivery bin latch on the lower delivery bin side of the monetary wall.
2. Lift the latch up to allow the delivery bin assembly to hinge down.
3. Lift up the delivery bin slightly and lift up on the drop rods to allow the rods to clear the stop brackets.
4. Slide the delivery bin assembly to the right to clear the hinges. The delivery bin assembly will not be attached to the machine.
5. Unhook the SureVend™ harness at the SureVend™ board, noting the wire routing.
6. Remove the screws that secure the bottom panel to the cabinet.
7. Pull the panel forward to remove it from the cabinet.

NOTE

To fit the merchandiser through some of the most narrow doorways, you may have to remove the trays. If you do, follow the procedure outlined on the following page.

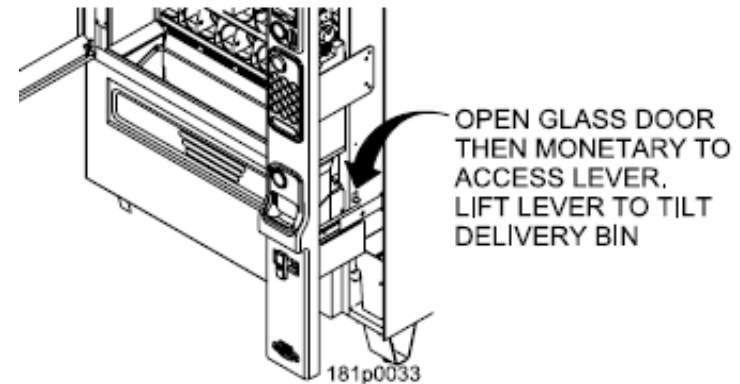

Figure 2

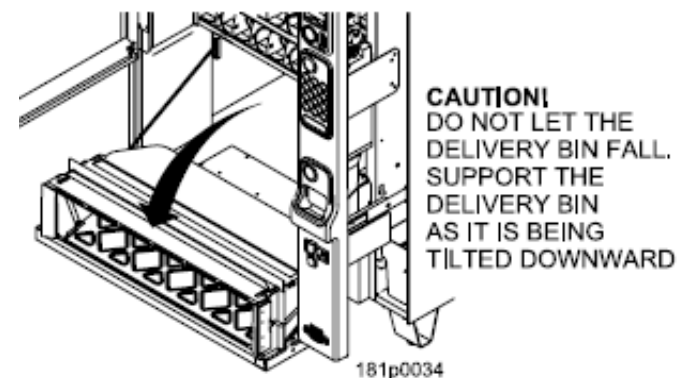
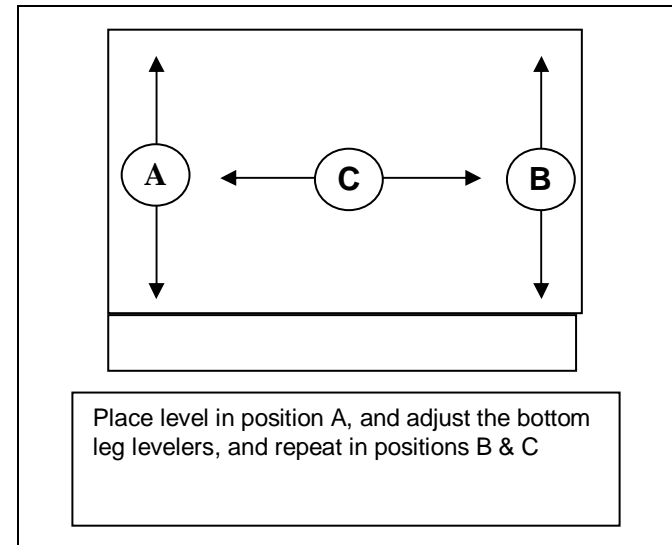

Figure 3

Installation

Leveling the unit

- **Leveling the Machine**
 - Leveling the machine on location is important for the proper function of the machine. There are four leveling screws in the legs of the machine to make any necessary adjustments. After positioning the machine, level it from front to rear and right to left directions. After leveling, turn front right (lock side) leveling screw in about one-half turn to drop this corner slightly to make the door easier to close and lock.



Installation Clearances

- **Clearance Requirements**
 - It is necessary on all machines to have 25mm (1") clearance on the left side of the machine for the door to properly open to access the shelves.
 - All chilled or refrigerated machines require 150mm (6") of clearance behind the machine for air circulation.

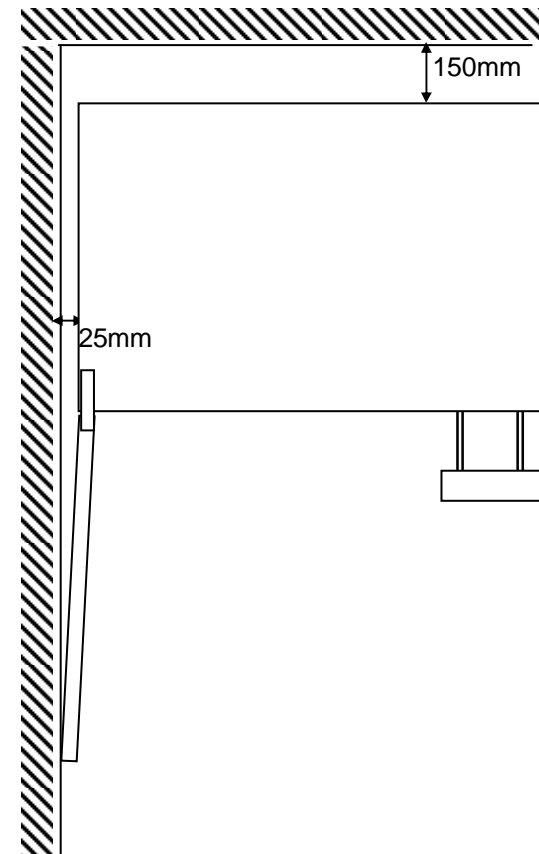

Installation

Electrical Supply Check



CAUTION: It is important that this machine is hooked up to the proper voltage and polarity for your country. Use a Voltmeter to verify voltage and polarity. Should the reading be any different than a normal reading or if you are unsure of what the reading should be, contact an electrician.

Power Requirements

The merchandiser is supplied with a service cord for the country of use and is terminated in a grounding type plug. The wall receptacle used for this merchandiser must be properly polarized, grounded, and of the correct voltage. Operating the merchandiser from a source of low voltage will **VOID YOUR WARRANTY**. Each merchandiser should have its own 15 Amp electrical circuit and that circuit should be protected with a circuit breaker or fuse conforming to local regulations.

1. **Voltage Check** - Place the leads of a voltmeter across the LINE (LIVE) and NEUTRAL terminals of the wall receptacle. The voltmeter should indicate 110-130 volts ac for 120 volt, 60 Hz locations, or 220- 240 volts ac for 230 volt, 50 Hz locations.
2. **Polarity Check** - Place the leads of a voltmeter across the LINE (LIVE) and GROUND terminals of the wall receptacle. The voltmeter should indicate 110-130 volts ac for 120 volt, 60 Hz locations, or 220- 240 volts ac for 230 volt, 50 Hz locations.
3. **Noise Potential Check** - Place the test leads of a voltmeter across the NEUTRAL and GROUND terminals of the wall receptacle. The meter should indicate 0 volts ac. A measurement greater than 1.5 - 2.0 volts ac could result in problems for the merchandiser's electronic circuitry caused by electrical noise.

NOTE

Any deviation from these requirements could result in unreliable performance from your merchandiser.

Filling the Machine

Loading the Machine

- A) Lift up shelf and pull out until it stops.
- B) Insert products into spirals
- C) Push shelf into machine until you feel the front edge of shelf ride over a ramp.

Note: If tall product hits shelf above when pushing in, lift the above shelf while pushing shelf in.

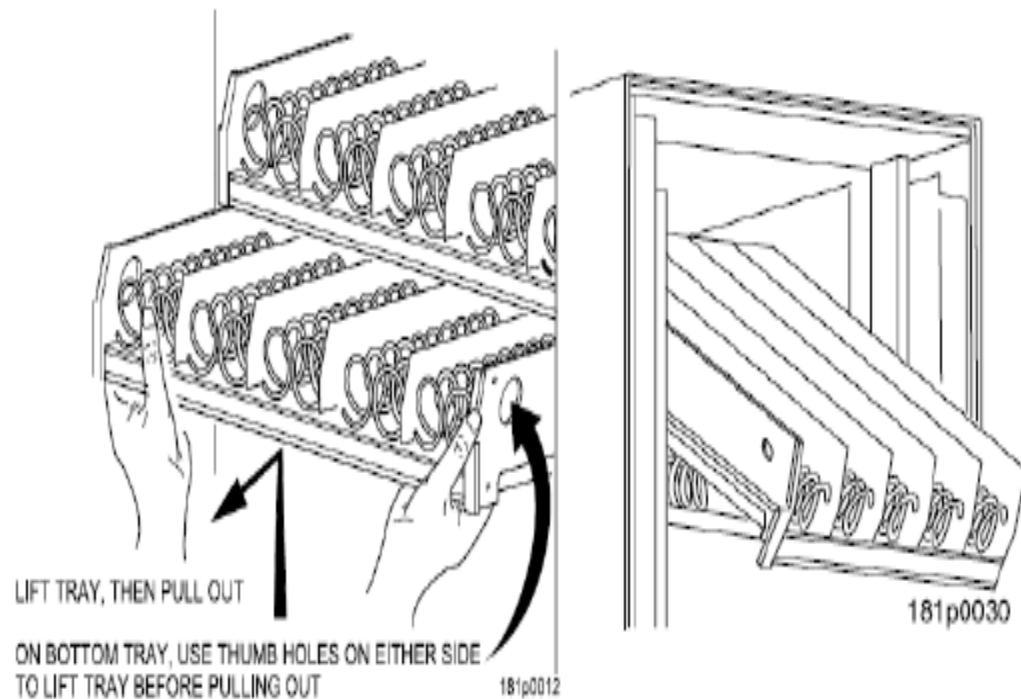

Payment Systems

- The Media Merchandisers are capable of accepting multiple forms of payment systems using a Multi Drop Buss or Executive (export only) interface.
- All payment devices are mounted on the slide out assembly. The front of this slide out assembly is called a Pill. There are multiple configurations of the Pill available should you need to add or take away payment peripherals in the future.
- If your payment peripherals were installed at the factory they should already be enabled in the electronics. Currently we enable only \$1 and \$5 bills in manufacturing. Instructions from the manufacturer for all peripherals installed at the factory are included in the bag assembly in the machine. Please refer to these instructions for information on filling coin tubes, adding bills to recyclers or other pertinent information.
- If your payment peripherals were not installed in manufacturing please refer to the instructions that came with payment system for set up and installation.
- See the service modes section of this document for information on enabling or disabling different bills and/or additional peripherals.

Initial Start Up

Powering up the machine

- Turn on the power switch located on front of the power box accessible by pulling out the swing panel.
- The Media Merchandisers run on the Linux operating system, it is essentially a computer so it will take several minutes to power up just like your computer at home.



Power Switch

Initial Start Up

Programming tips

- This Programming Guide is based on software version 10.5.X
- The software version is shown on the bottom right of the display anytime you are in the Service mode. The software version can also be displayed by pressing the Firmware Information icon in the service mode and reading the LE board information.
- Earlier or later versions of software may not contain all the same menus and/or options. Some Menu items may also be in different places within the menus & program differently.
- This programming guide is specific about what button numbers to push within the Modes. When certain Menu items are enabled and disabled additional menu items may appear or disappear. Most of the time this guide will be correct but rely on the display for the correct buttons to push.

Initial Start Up

Quick Start Tips

Below is a list of Menus that should be set up or checked before operating the Machine.

1. When opening the service door on the machine you will be prompted for a PIN, enter 3333 on the keypad.
2. Set the Prices by selecting button 4 in the service mode.
3. Make sure the Shopping Cart Size (max 3) and Shopping Cart Max Value is set to 3 X the highest price in Product Configuration. Press button 5 in the service mode and choose Shopping Cart Setup.
4. If you have added, moved or removed any motors go to Product Configuration, Press button 5 in the service mode, choose 1 Selection Configuration, then 1 for Auto Configuration and 1 again to start Auto Configuration.
5. If any motors are being coupled on the candy tray or squat tray go to Product Configuration, button 5 in the service mode and choose Couple Motors.
6. Verify your Coin Mechanism, Bill Validator and Card Reader are enabled in the Monetary Menu, button 7.
7. Verify the bills you want to accept are enabled in the Monetary Menu, button 7.
8. Set the Time and Date in the System Setting Menu, button 8.

Initial Start Up

Quick Start Tips

If your machine contains a refrigeration unit you must also set the following;

1. Verify or set the Configuration Version, go to System Settings (button 8). Press the lower half of the OK button to scroll down and verify the Configuration Version is set correctly.
2. To change the Configuration Version press 6, your options are Refrigerated, Non-perishable and Chilled. Do not choose European Control unless your area is within the region covered by these requirements.
3. Press OK to save your choice.
4. Next select Refrigeration Settings (button 7), this menu does not appear if the machine is set to Ambient.
5. Choose 1 to adjust Temperature if desired.
6. If set to Refrigerated choose button 3 to assign the selections to work with Health Control. The health control menu will not appear if you machine is set to anything other than Refrigerated.

Keypad and Screen

- The new Merchant Media platform uses a 3½” LCD screen to provide instructions and information required by the customer to purchase items in conjunction with a 14 button keypad integrated into the cladding on the monetary panel of the machine.
- Keypad also provides access to all Service Mode menus.

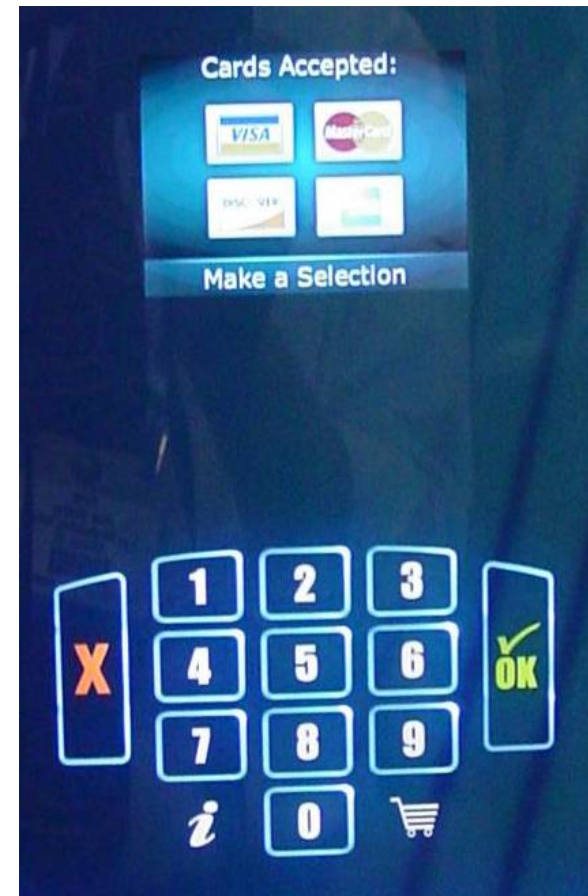

Accessing the Service Modes

- When the monetary compartment is opened, the display will prompt the operator to enter a PIN number on the keypad to gain access to the service modes.
 - The default PIN for route driver access is **1111** (limited access).
 - The default PIN for programming access is **3333**.



Service Modes

Initial Screens

If **Errors Exist**, an error list will be shown on the display that includes the time and date of the errors.

To escape to the home screen press the highlighted **red X**.

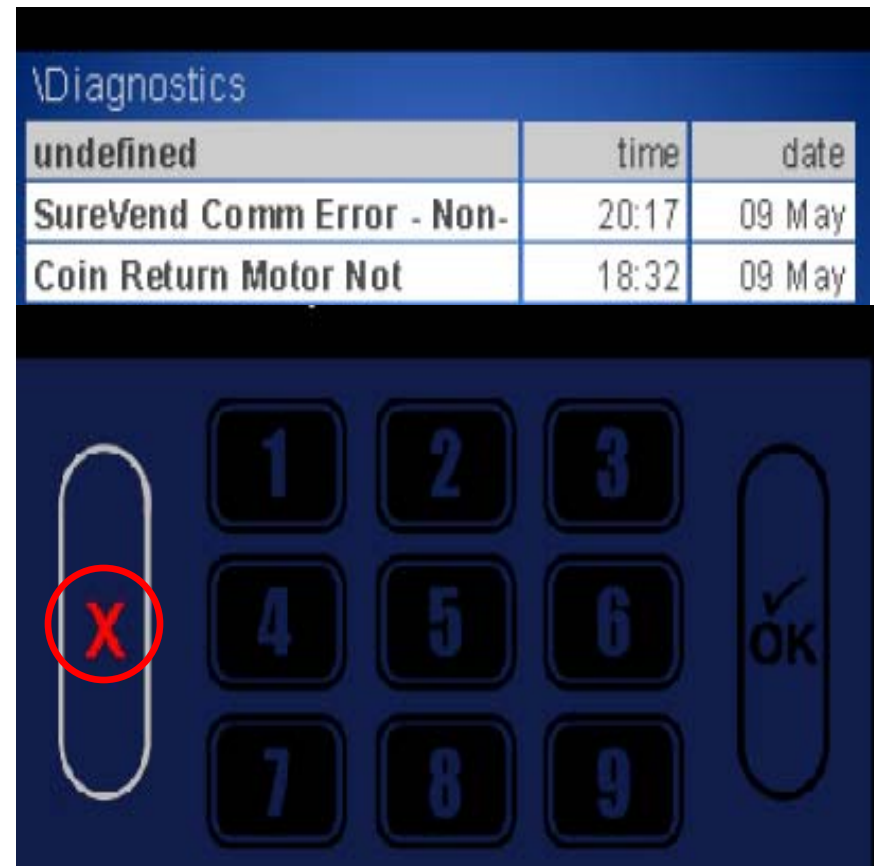

How Do I Access the Service Modes?

If PIN number **1111** was entered and **No Errors Exist**, the home screen for the Route Driver menu will appear. This menu allows limited access to the service modes. Pressing the corresponding key on the keypad will provide access to that menu

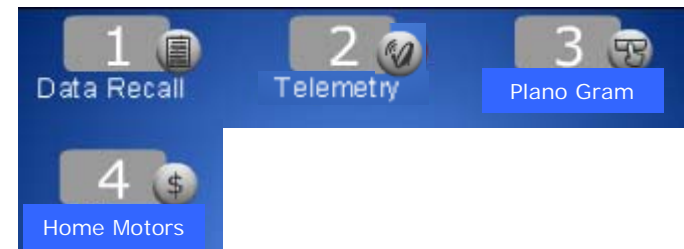

Route Driver access allows you to:

1. View Resettable and Non Resettable sales data.
2. Send a wireless Dex read.
3. Manage the existing Plano gram.
4. Home all Un-homed Motors.

For access to all other service modes use PIN # 3333

How Do I Access the Service Modes?

- If PIN number **3333** was entered and **No Errors Exist**, the home screen for the programming menu will appear allowing access to the service modes.
- Pressing the corresponding key on the keypad will provide access to that menu.
- Each of these icons represents a tiered menu that provides access to each of the menu items.



How do I use the keypad?

The backlit keypad includes:

- A. An OK (enter or save) key.
- B. The numeric keys 0 through 9.
- C. An X or cancel, or Escape key.
- D. An Information button.
- E. A Shopping Cart Button.
- F. Home – Although not backlit or identified on the keypad, if you press the area below the X and to the left of the information button (indicated by the red circle) the display will return to the home screen.

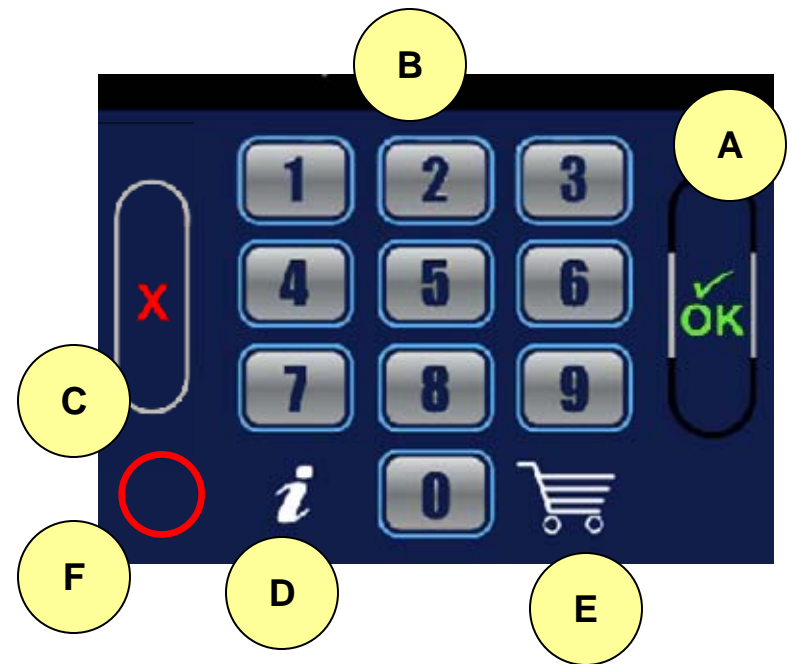







How do I use the keypad?

- A unique feature of the backlit keypad is the ability to illuminate only the specific buttons applicable to that process.
 - This is especially important during the service modes as certain functions will only permit the use of defined (lit) buttons, all others are disabled
- The X and OK keys have the ability to provide a scrolling feature in certain service modes by pressing the top or bottom of the long rounded buttons, when illuminated.



Menu Chart

Service Mode Menu Chart Menus 1 to 6







| 1  | 2  | 3  |
|--|--|---|
| Data Recall Non Resettable Sales Data Resettable Sales Data Events Identification Number SureVend™ Corrected | Diagnostics Shows Errors w Time Date | Test Test Vend Coin Return Motor Surround Lighting Test Screen Test MagTeck Head Test Refrigeration System SureVend Calibration Motor Test Summary Detailed Motor Test Lighting Relay Keypad Test |
| 4  | 5  | 6  |
| Price Individual Selections Entire Machine Price Tray 1 Price Tray 2 Duplicates for all trays | Product Configuration Selection Configuration FIFO Set Up Universal Product Code Shopping Cart Setup View Planogram Couple Motors SureVend | Special Vend Modes Free Vend Winner Vend Combo Vend Token Enabled Rapid Vend |

| | | |
|---|--|---|
| 1  Data Recall | 2  Diagnostics | 3  Test |
| 4  Price | 5  Product Configuration | 6  Special Vend Modes |
| 7  Money | 8  System Settings | 9  Security Codes |
| i  Timed Events | 0  Telemetry | L  Firmware Information |

Menu Chart

Service Mode Menu Chart

Menu 7 to End

| 7  | 8  | 9  |
|--|--|---|
| <ul style="list-style-type: none"> Coins In/Out Bill Validator Coin Mechanism Card Reader Bill Acceptance Declining Balance Change Without Purchase Accept On Low Change Low Change Message Credit For Failed Vend Card Revalue | <ul style="list-style-type: none"> Machine Information Time & Date Language DTS Software Updates Backup/Restore Copy Configuration Custom Configurations Screen Brightness Led Color Idol Timeout Advertisements Custom Messages Configuration Version Refrigeration Settings | <ul style="list-style-type: none"> Enter Pin Change Route Pin Change Operator Pin |
| i  | 0  | L  |
| <ul style="list-style-type: none"> Time of Day Events Backup Events Power Save Events | <ul style="list-style-type: none"> Send Dex Ping Server Sync Time w Server Get Network Status Send Log Files Update Configuration Load Network Get Cashless Terminal Cfg Enable Mesh Assign Unit Un Assign Unit | <ul style="list-style-type: none"> Peripheral Firmware Info SureVend Version I/O Board Version LE Board |





Data Recall Menu

- The Data Recall Menu permits the operator to review a variety of accountability and operational information including:
 - Non Resettable Sales Data
 - Resettable Sales Data
 - Events
 - ID Numbers (boards & peripherals)
 - SureVend Corrected Vends

Only the applicable Index buttons on the keypad will be lit.

- Pressing the Index key will access the next level in the menu.
- Click on one of the 5 illuminated buttons to advance to the tiered menu for that item.

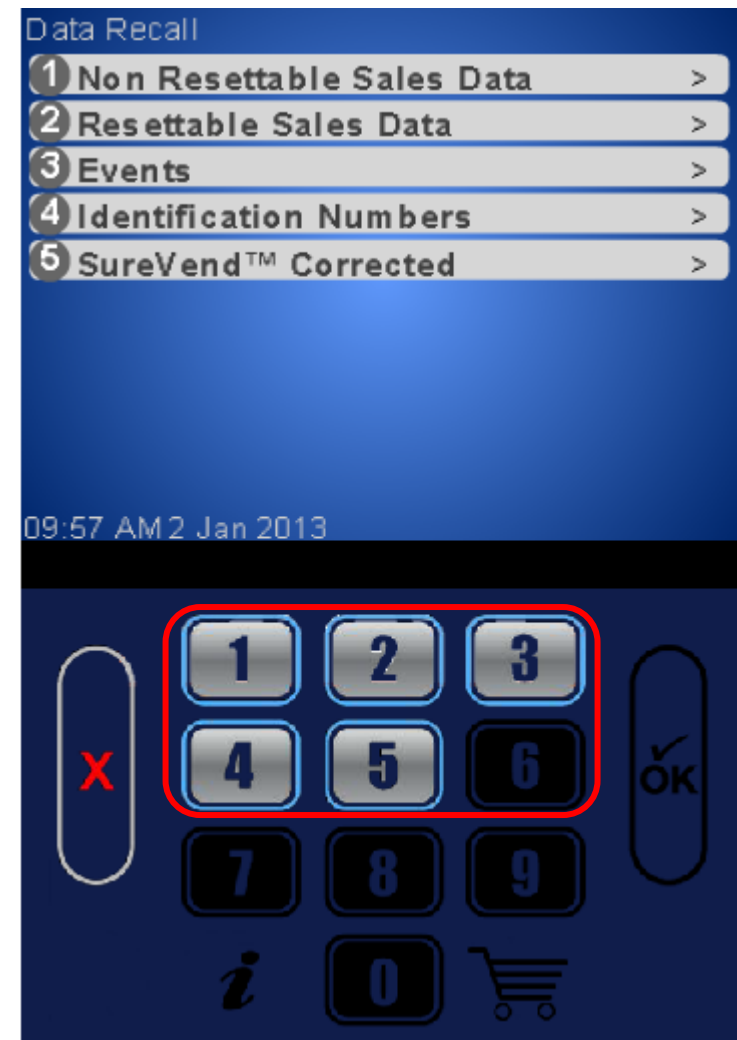



Data Recall Menu

Non Resettable Data

- Non Resettable Sales Data has 7 categories, permitting the operator to review each level of data individually.
- Press:
 - Button 1 = Overall Totals
 - Button 2 = By Tray
 - Button 3 = By Product
 - Button 4 = Cash
 - Button 5 = Cashless
 - Button 6 = Token
 - Button 7 = Bill Data





Data Recall Menu - Non Resettable Data

Overall Totals

Press button 1 to view the Overall Totals

This screen shows a summary of Overall Totals
Press the **X** key to return to the previous menu



| | | # |
|--------------|-----------------|-----------|
| Sales | \$50.00 | 5 |
| Discounts | \$0.00 | 0 |
| Surcharge | \$0.00 | 0 |
| Test Vend | \$180.00 | 18 |
| Free Vend | \$0.00 | 0 |
| Total | \$230.00 | 23 |

1 Data Recall

Data Recall Menu

Non Resettable Data by Tray

Press 2 to view sales information by tray.

Choose a tray number on the keypad to see the sales data for that tray.

Totals for the tray selected are shown on the display.
Press **X** to exit.

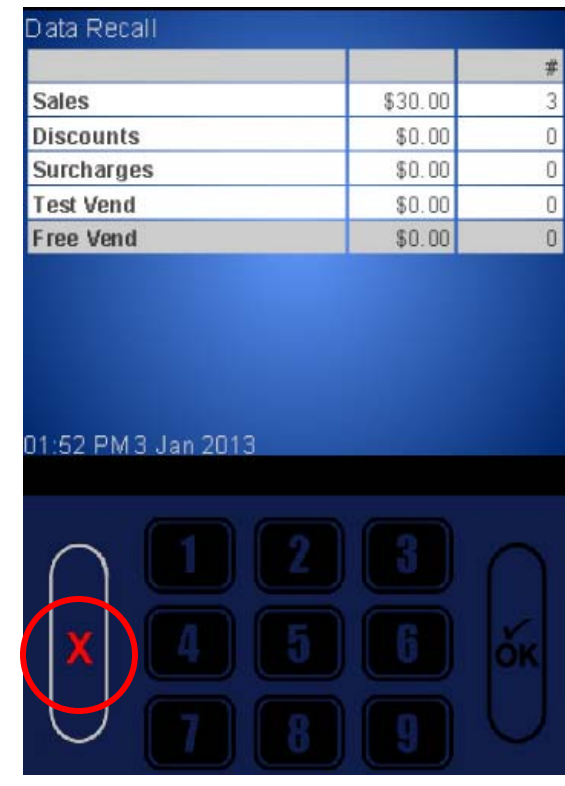
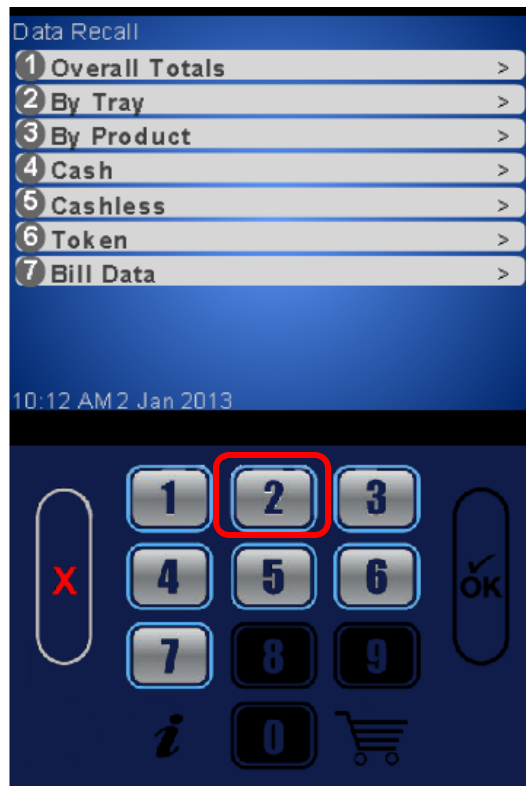



Data Recall Menu

Non Resettable Data by Product

Press 3 to view Sales Data by product.

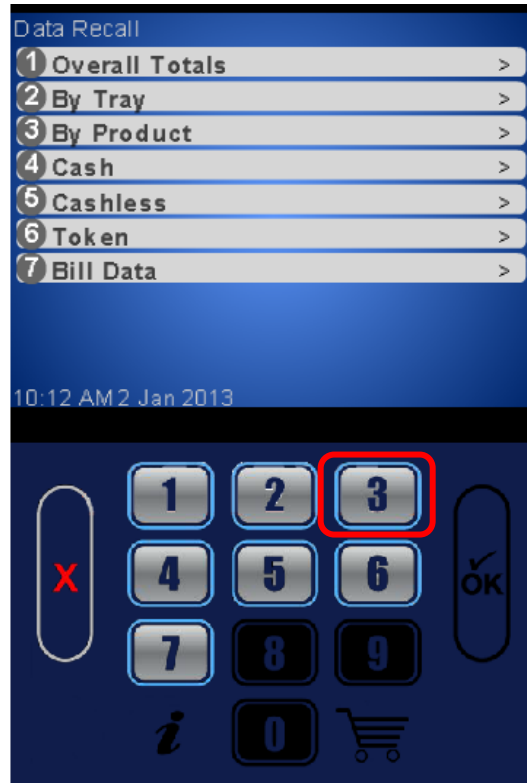

Choose a tray number on the keypad to see the sales data for that tray.

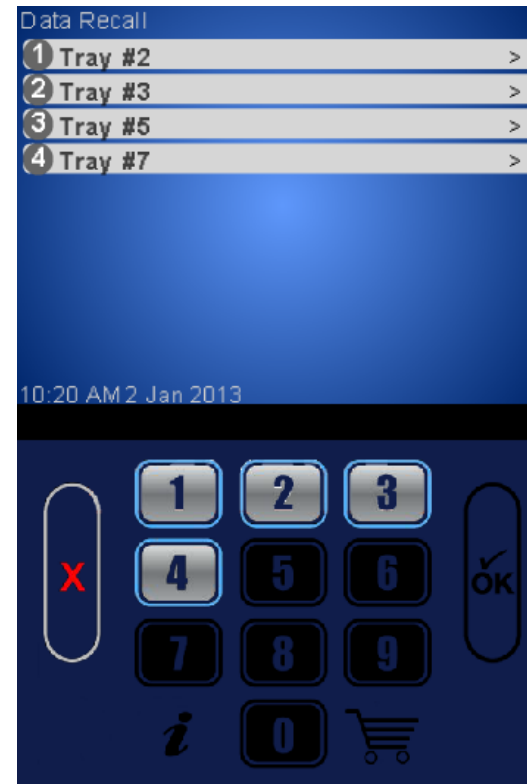



Data Recall Menu

Non Resettable Data by Product

The UPC code will show up when used along with the selection number. Press a number on the keypad to view Data by Product. Press the bottom of the OK button to scroll down to additional selections.

Totals for the selection chosen are shown on the display, including the last vend with the time & date.

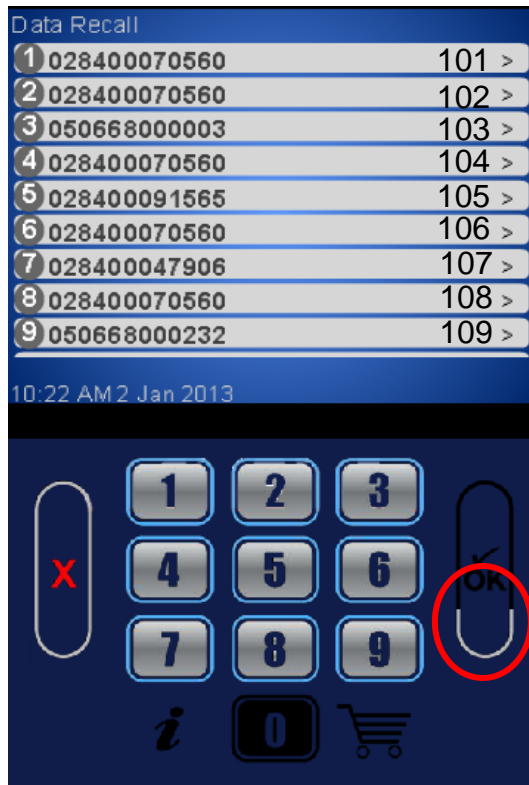

| Data Recall | | |
|-------------|----------------------|---|
| | | # |
| Price | \$10.00 | |
| Sales | \$0.00 | 0 |
| Discounts | \$0.00 | 0 |
| Surcharge | \$0.00 | 0 |
| Test Vend | \$0.00 | 0 |
| Free Vend | \$0.00 | 0 |
| Last Vend | undefined//undefined | |

1 Data Recall

Non Resettable Data Cash Totals

Press button 4 to view the Cash Totals

Note: The bottom of the OK key is illuminated to permit you to scroll down to the bottom of the list.

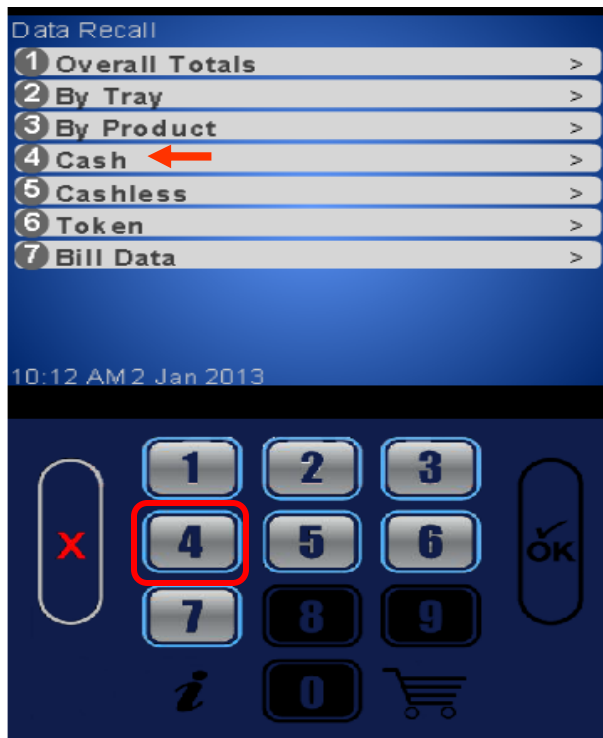

A screenshot of the 'Cash Totals' data table. The table has three columns: Description, Amount, and Count. The data rows are: Cash In (\$2.00), To Cashbox (\$0.00), To Tubes (\$0.00), Bills In (\$2.00), Dispensed (\$0.00), Manual Dispensed (\$0.00), Sales (\$50.00, 5), Discounts (\$0.00, 0), and Surcharge (\$0.00, 0). Below the table is a numeric keypad with a red circle around the bottom of the 'OK' key. The time and date '10:28 AM 2 Jan 2013' are displayed at the bottom.

| | | # |
|------------------|---------|-----|
| Cash In | \$2.00 | ___ |
| To Cashbox | \$0.00 | ___ |
| To Tubes | \$0.00 | ___ |
| Bills In | \$2.00 | ___ |
| Dispensed | \$0.00 | ___ |
| Manual Dispensed | \$0.00 | ___ |
| Sales | \$50.00 | 5 |
| Discounts | \$0.00 | 0 |
| Surcharge | \$0.00 | 0 |



Data Recall Menu

Non Resettable Cashless Sales Data

Press button 5 to view the Cashless Totals

This Screen shows Cashless Sales and number of Cashless vends by vend type, including Revalue if applicable

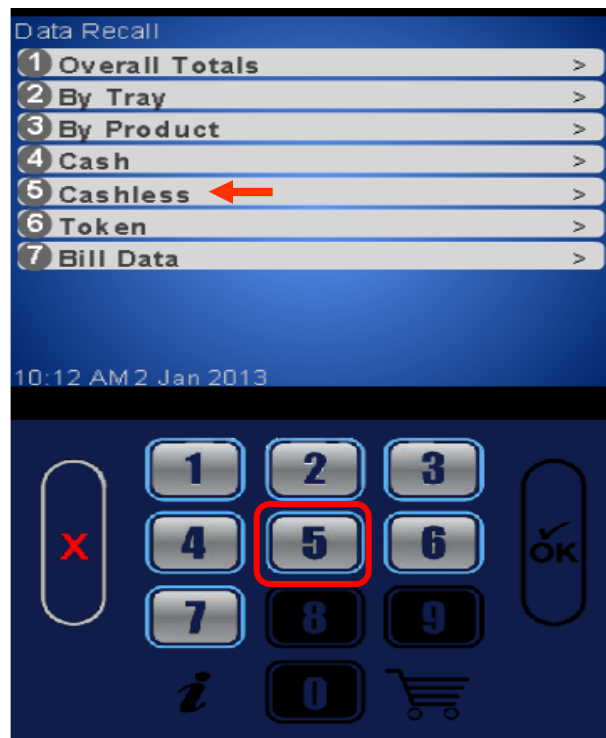

| Data Recall | | |
|-------------|--------|---|
| | | # |
| Sales | \$0.00 | 0 |
| Discounts | \$0.00 | 0 |
| Surcharge | \$0.00 | 0 |
| Revalue | \$0.00 | 0 |



Data Recall Menu

Non Resettable Token Sales Data

Press button 6 to view the Token/Coupon Totals

This Screen allows you to view Token sales, both by value and number of Tokens/Coupons vends.

Tokens and Coupons are both considered Tokens in accountability and setup. See Token setup in this manual.

Note: This menu is only displayed if Tokens/Coupons are enabled in the monetary menu under Bill Acceptance.



| Data Recall | | |
|-------------|--------|---|
| | | # |
| Vend Tkn | \$0.00 | 0 |
| Value Tkn | \$0.00 | 0 |
| Overpay | \$0.00 | 0 |



Data Recall Menu

Non Resettable Bills Sales Data

Press button 6 to view the Bill Sales Data

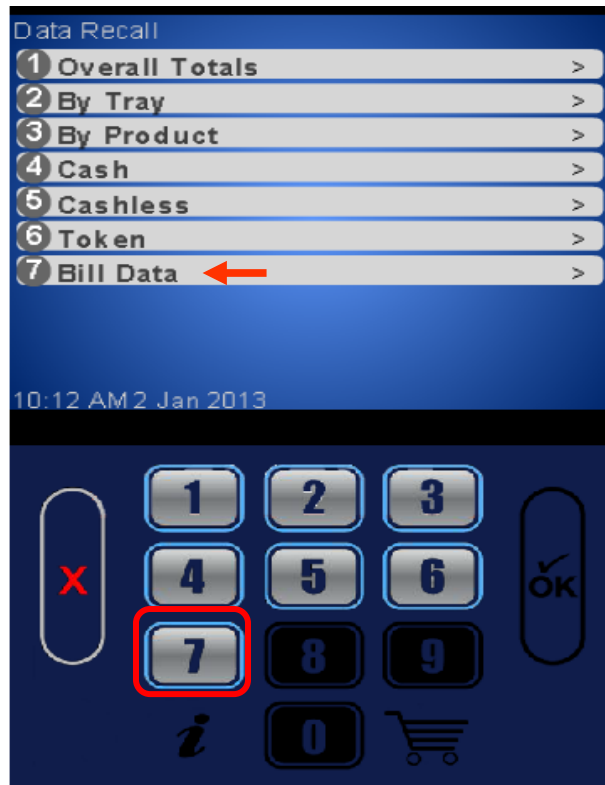

- This Screen allows you to view information about bills by denomination, both accepted and paid out when using a validator or recycler.
- Also included is the current value of bills stored in a recycler cassette

| Data Recall | | |
|--------------------------|--------|---------------|
| | In | Out |
| One | \$0.00 | \$0.00 |
| Two | \$0.00 | -/- |
| Five | \$0.00 | \$0.00 |
| Ten | \$0.00 | -/- |
| Twenty | \$0.00 | -/- |
| Fifty | \$0.00 | -/- |
| Hundred | \$0.00 | -/- |
| Recycler Contents | | \$9.00 |

1 Data Recall

Data Recall Menu Resettable Data

- This menu provides access to the interval or resettable sales data.
- The format of each of the menus is exactly the same as the Non-Resettable Data screens, therefore not duplicated in this programming guide.
- There is one additional menu in the Resettable menu, Clear Data. This menu allows you to clear the resettable data. The Non-Resettable Data can not be reset.
- This resettable data is also cleared each time the machine successfully transmits a DEX file if the option in System Settings, DTS is set to Auto.

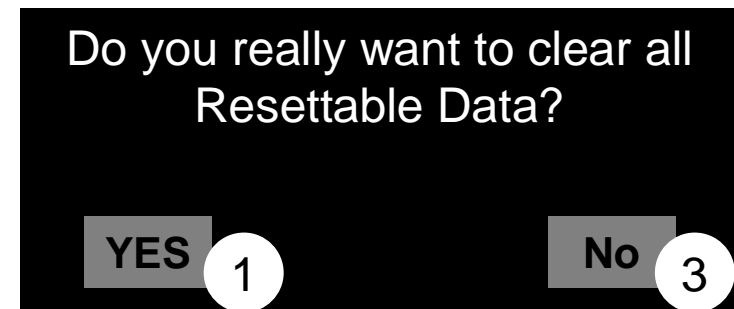
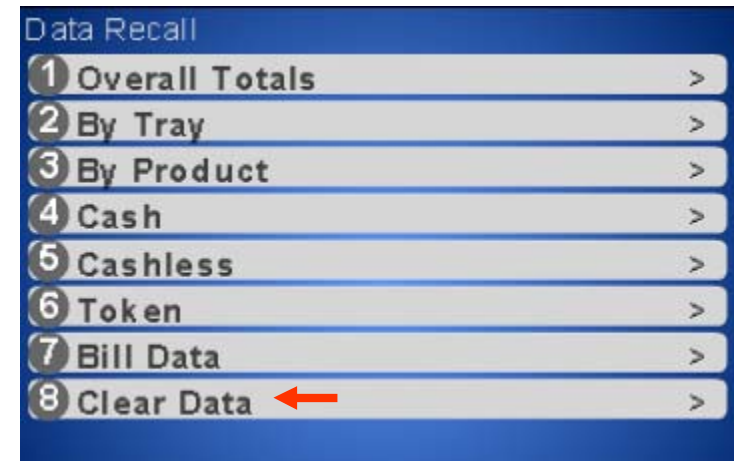



Data Recall Menu

Events

Event History

This menu allows the operator to review the most recent times for the following events:

- Press 1 for Power Loss history
- Press 2 for Door Open History

The following Event History will show on the display without entering a Menu.

- Last Data Clear
- Last Vend Information
- Last Piece Change
- Last Clock Set
- Last Health Control Event (if set to refrigerated).

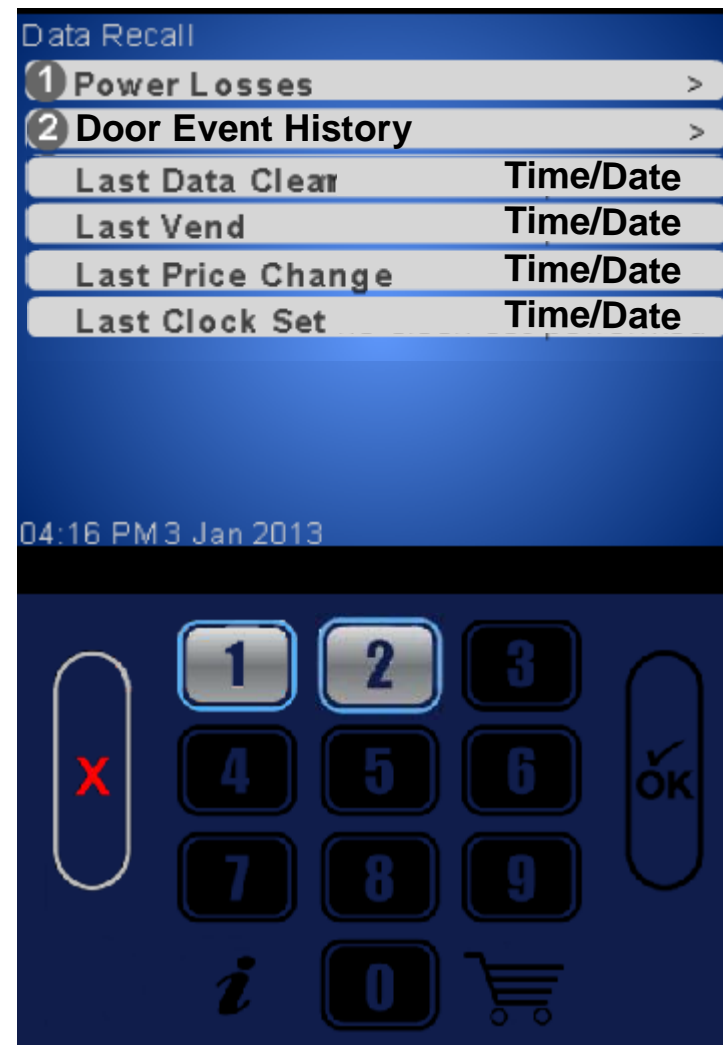



Data Recall Menu

Events – Power Losses

Press 1 to view
Power Loss History

Power Losses are shown on the
display including Duration, Date
and Time

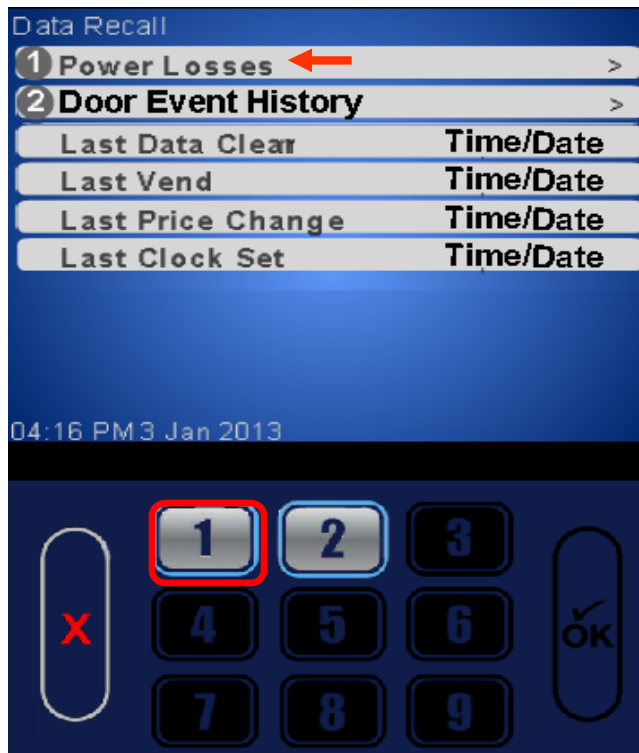

| Duration | Date | Time |
|-----------------|----------|----------|
| 42 hours 21 min | 08/01/13 | 18:02:46 |
| 2 hours 30 min | 07/01/13 | 06:05:21 |
| | | |
| | | |
| | | |
| | | |



Data Recall Menu

Events – Door Events

Press 2 to view Door Events History

The Door Events are shown on the display including Date and Time

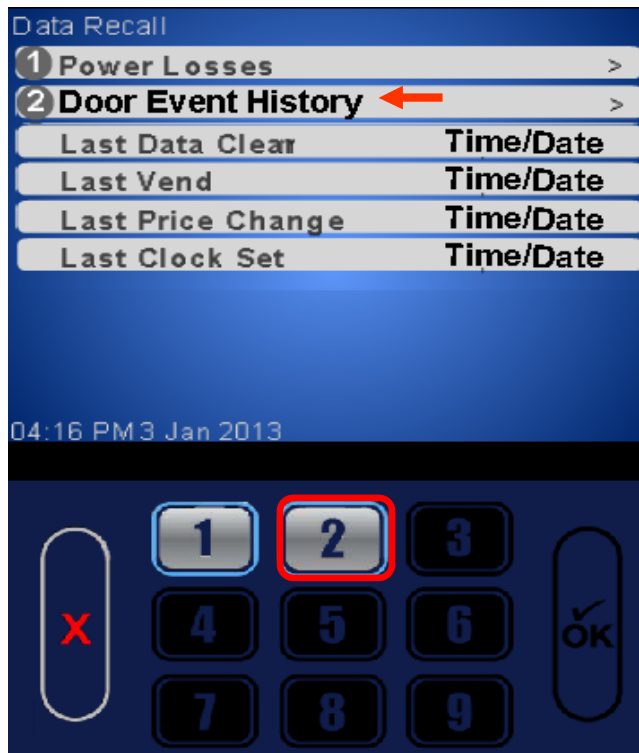

| Event | Date | Time |
|------------|----------|----------|
| Door Open | 08/01/13 | 18:02:46 |
| Door Close | | |
| Door Open | | |
| Door Close | | |
| Door Open | | |
| Door Close | | |



Data Recall Menu Identification Numbers

Press 4 for Identification numbers

All Items attached to the controller using MDB communications will be shown. Press **X** to exit.

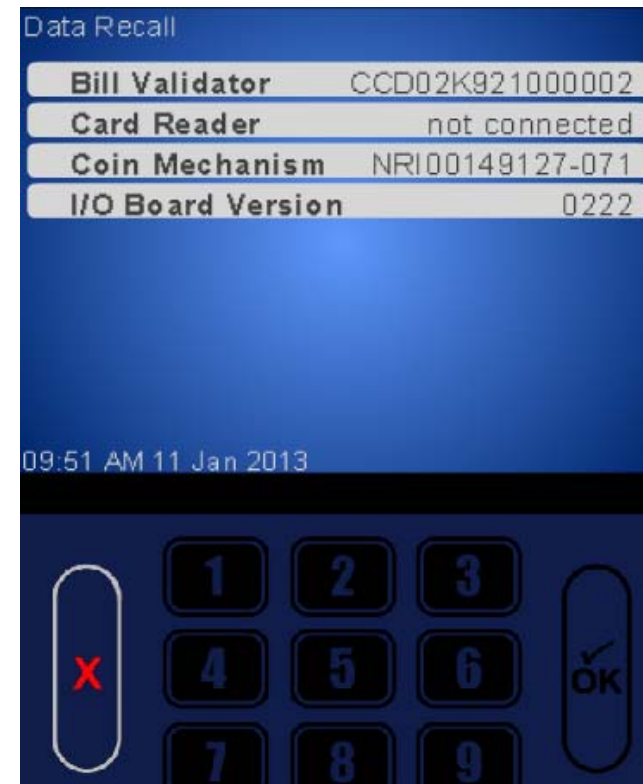
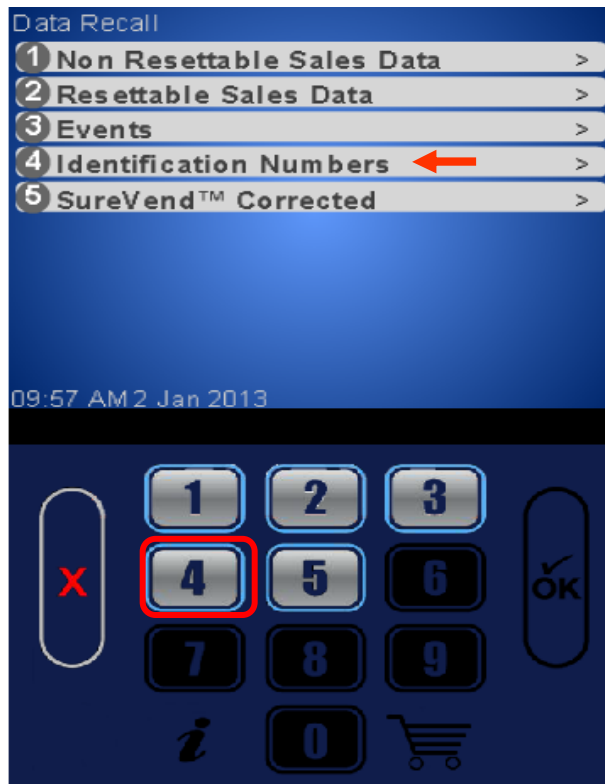



Data Recall Menu SureVend™ Corrected

SureVend™ Corrected

This menu allows the operator to review the number of SureVend™ Corrections.

- Press 1 to view Machine and Tray Totals.
- Press 2 to view by product.

The list of the last corrected vend information is viewable without entering the menu.



Continued →

1 Data Recall

Data Recall Menu SureVend™ Corrected

Press 5 to view
SureVend™ corrected
information

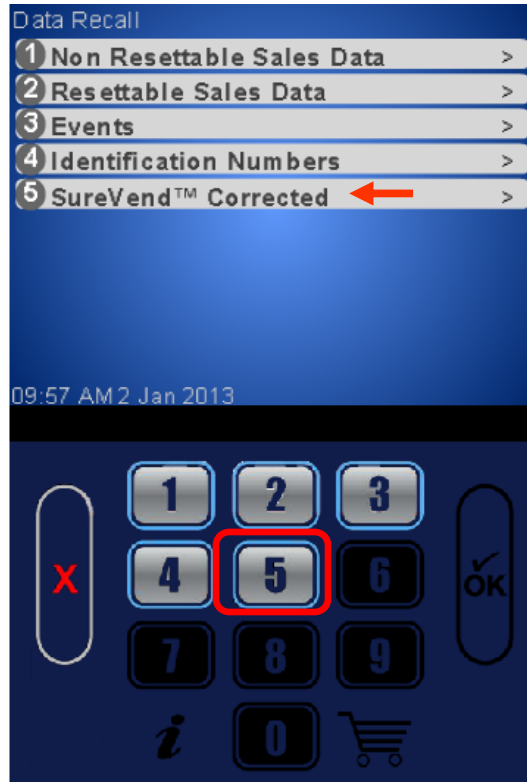

Press 1 to view
SureVend™ corrected
totals by Machine or tray



The display will resettable &
non resettable SureVend™
corrected totals by Machine
and Tray

| Data Recall | | |
|---------------|---|----|
| | R | NR |
| Machine Total | 0 | 0 |
| Tray #1 | 0 | 0 |
| Tray #2 | 0 | 0 |
| Tray #3 | 0 | 0 |
| Tray #4 | 0 | 0 |
| Tray #5 | 0 | 0 |
| Tray #6 | 0 | 0 |
| Tray #7 | 0 | 0 |

1 Data Recall

Data Recall Menu SureVend™ Corrected

Press 2 to view
SureVend™ corrected by
selection

Choose a tray to view
SureVend™ corrected
information by selection

The display will show
resettable & non resettable
SureVend™ corrected totals
by Selection

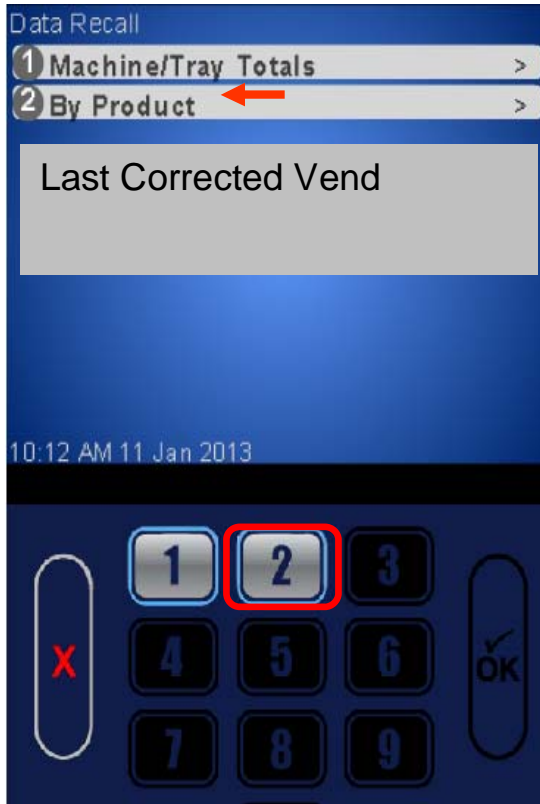

| Data Recall | | |
|-------------|---|----|
| | R | NR |
| 201 | 0 | 0 |
| 202 | 0 | 0 |
| 203 | 0 | 0 |
| 204 | 0 | 0 |
| 205 | 0 | 0 |
| 206 | 0 | 0 |
| 207 | 0 | 0 |
| 208 | 0 | 0 |
| 209 | 0 | 0 |
| 210 | 0 | 0 |



Diagnostics Menu

Diagnostics

- Pressing 2 on the keypad will cause the Diagnostics screen to appear. This screen shows the errors along with time and date they occurred.
- This screen will automatically appear when entering the service mode if errors currently exist.
- The errors do not need to be cleared, once corrected the error will be erased.
- If the error screen is full the bottom of the OK button will be lit allowing you to scroll to a second screen of errors.

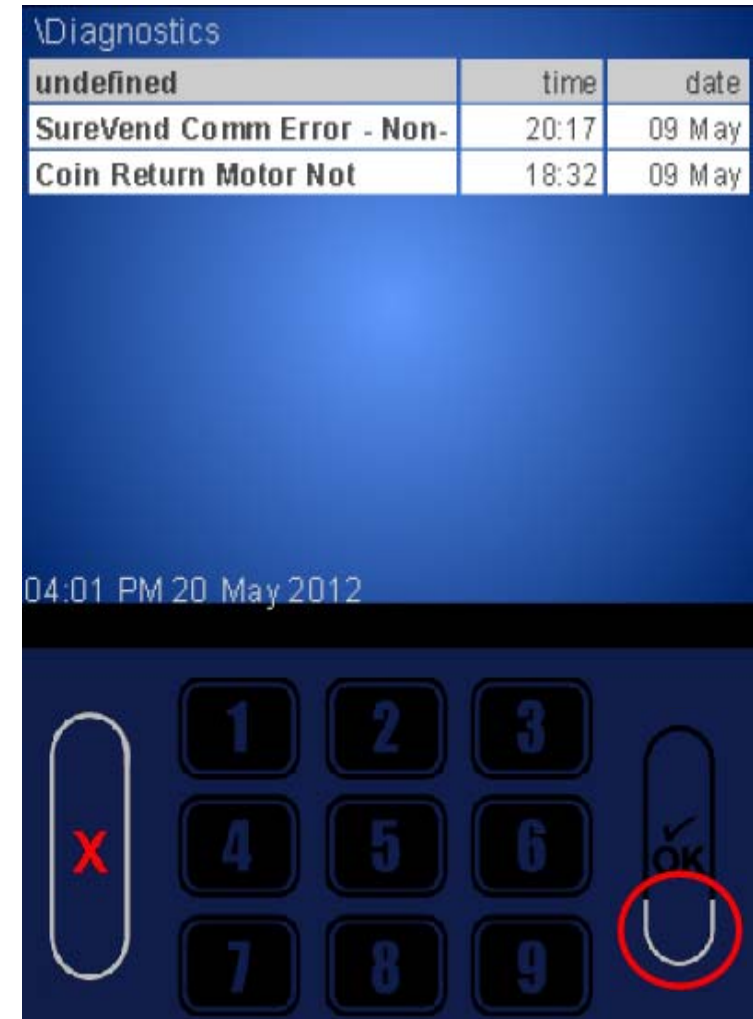

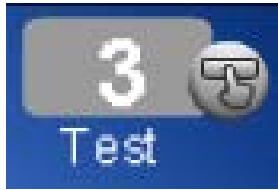

Test Menu

Press 3 on keypad to access the Test Menu.

- To test any of the menu items shown press the number to the left of the description on the keypad.
- Press the **Half Circle** under the OK button to scroll down to Light Relay & Keypad Test

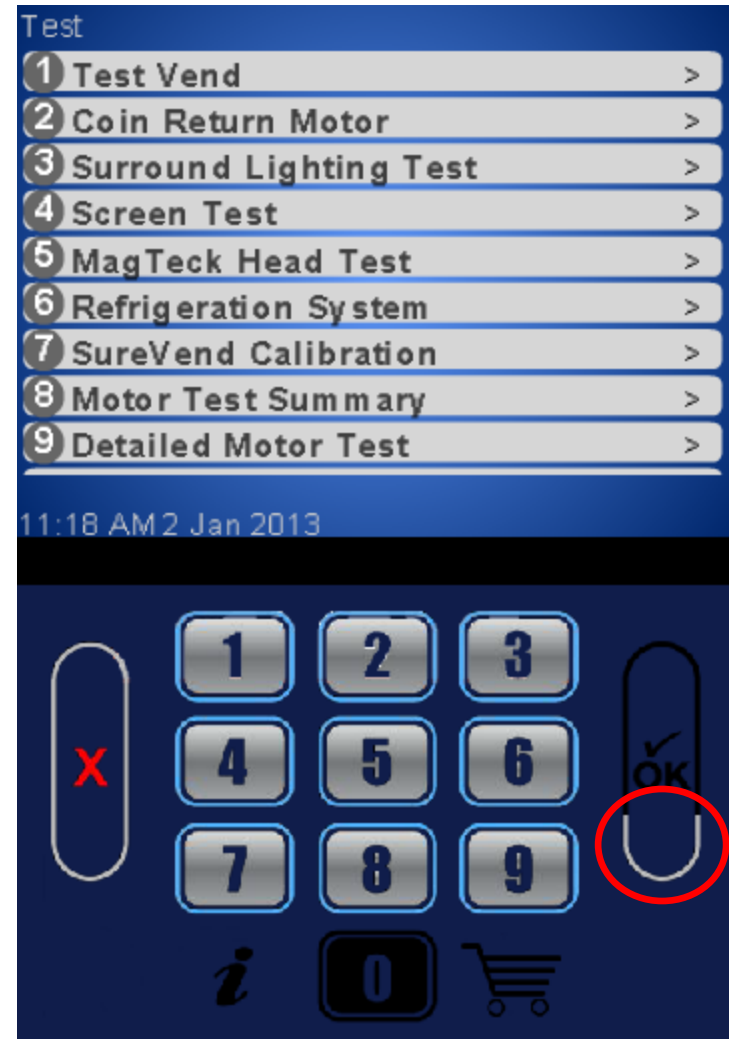

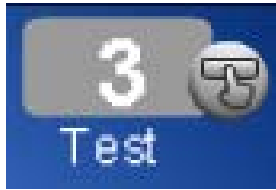

Test Menu

Test Vend

Press 1 for Test Vend

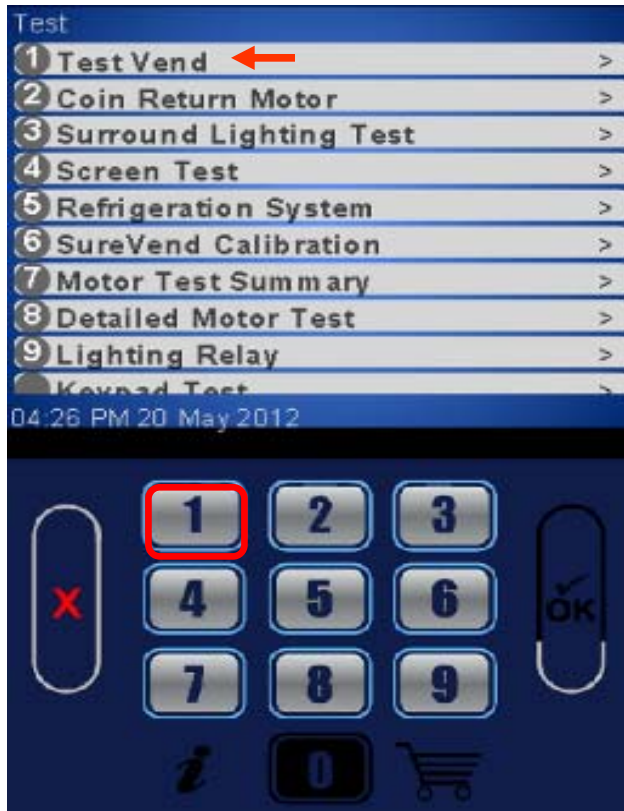

Press 1 to enable or disable SureVend™ for the test.

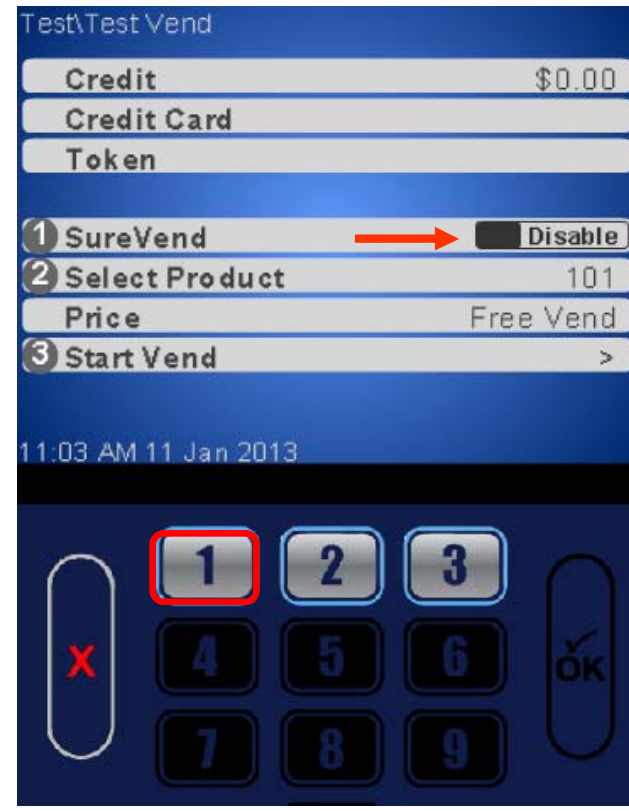

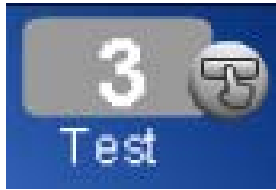

Test Menu

Test Vend

Press 2 and enter the selection number to be tested, followed by OK



Press 3 to test the selection entered.

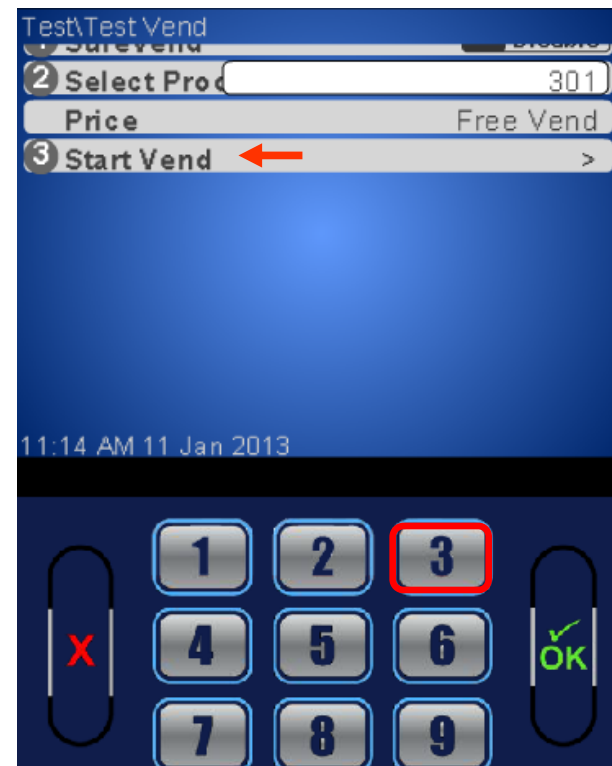

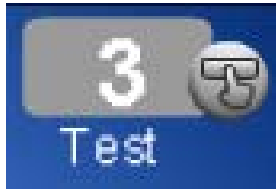

Test Menu

Coin Return Motor

Press 2 to test the coin return Motor

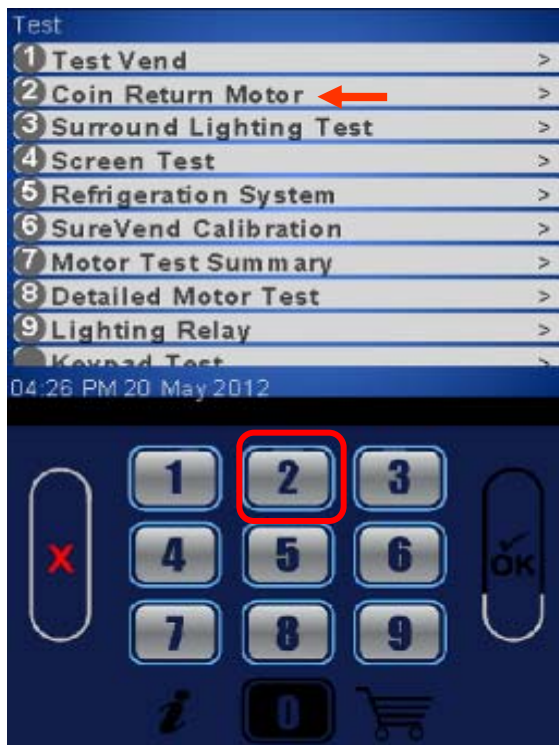

The display will show Coin Return motor should now be running,

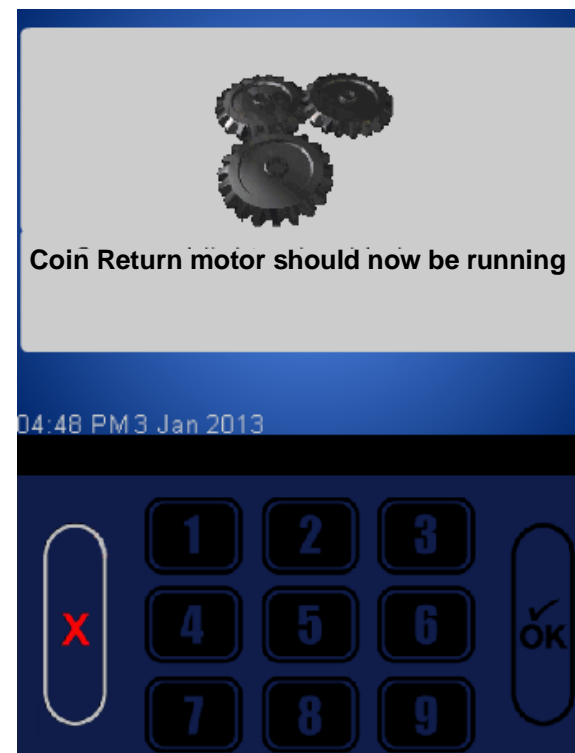

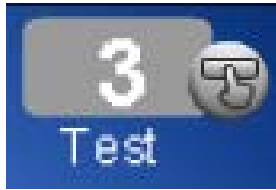

Test Menu

Surround Lighting Test

Press 3 for Surround Lighting Test

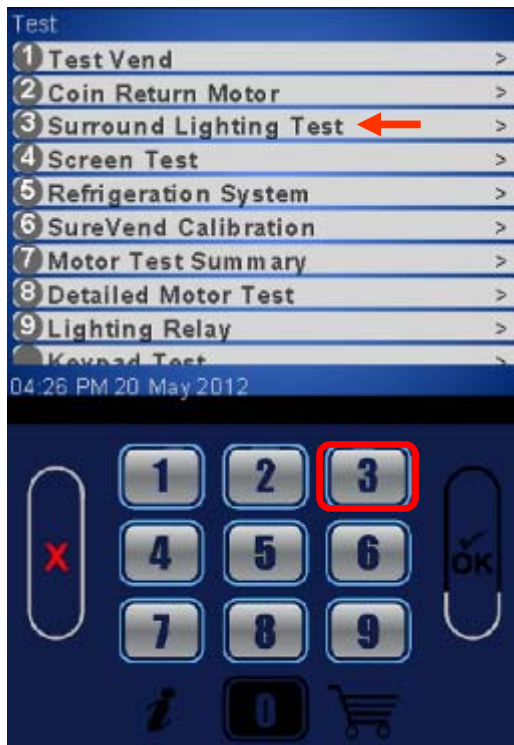

Press 1 to confirm Lighting Test



The Surround lights should be changing colors

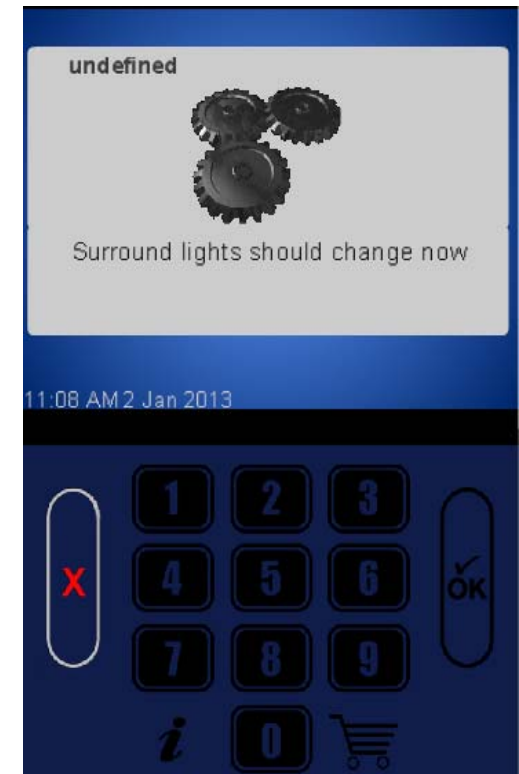

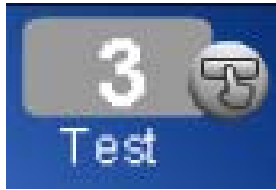

Test Menu Screen Test

Press 4 for Screen Test

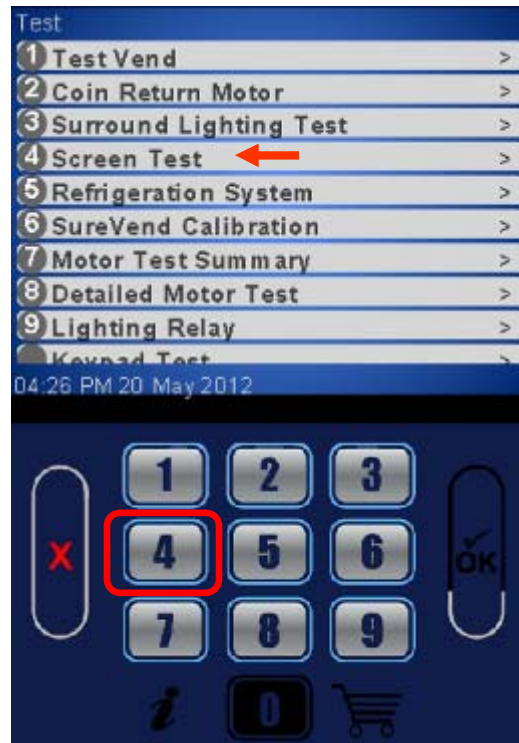

The display will illuminate
with Red, Green & Blue.
Press X to Exit.



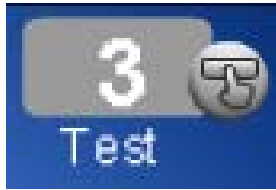

Test Menu

MagTeck Head Test

Press 5 for MagTeck Head Test

Swipe Card to test Magnetic Head. The display will keep track of how many good swipes versus bad, 28 good swipes out of 30 is considered passing

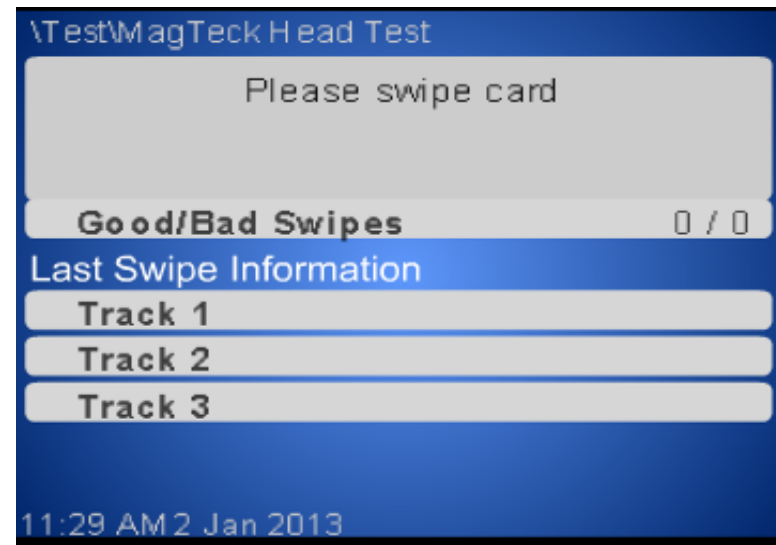
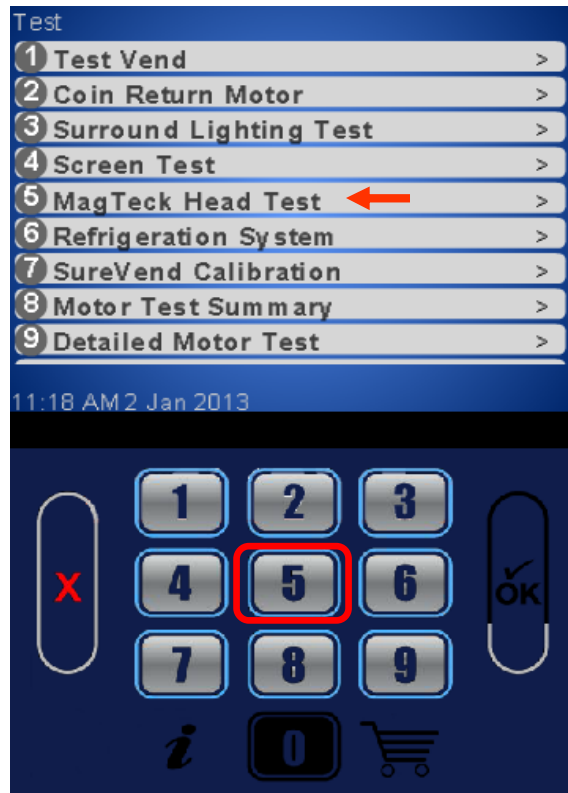

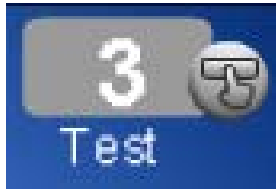

Test Menu Refrigeration System

Press 6 for Refrigeration System Test

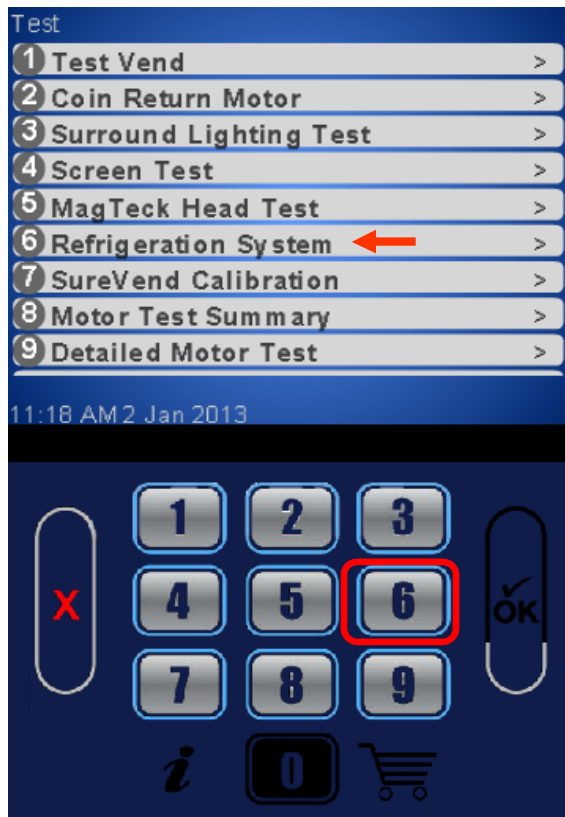

The display will show the current temperature for all the sensors in the machine as well as the current refrigeration Status ON/Off/Idle/Defrost and Time left on Health if applicable.

Pressing 1 will start a Refrigeration Deck Test

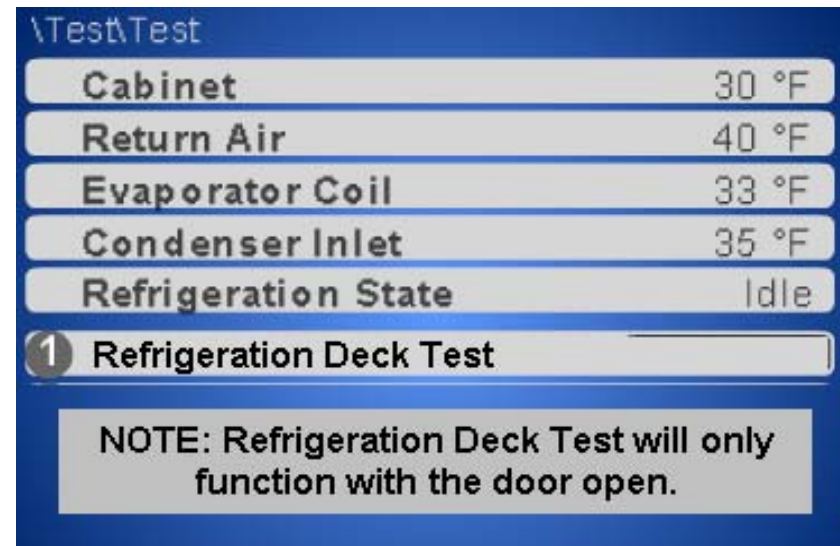

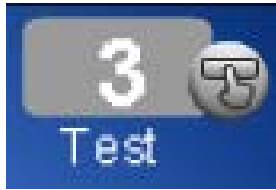

Test Menu

Refrigeration System

Press 1 to proceed to the Refrigeration Deck Test Menu

Note: The refrigeration Deck Test will only function with the door open

\Test\Test

| | |
|------------------------------------|-------|
| Cabinet | 30 °F |
| Return Air | 40 °F |
| Evaporator Coil | 33 °F |
| Condenser Inlet | 35 °F |
| Refrigeration State | Idle |
| 1 Refrigeration Deck Test ← | |

NOTE: Refrigeration Deck Test will only function with the door open.

Press 1 to toggle Compressor On/Off

Press 2 to toggle Evaporator Fan On/Off

\Test\Test

- 1 Toggle Compressor** >
Current Status - Off
- 2 Toggle Evaporator Fan** >
Current Status - Off

Warning! Compressor should not be turned on if it has been less than two minutes since it was last energized.

The Evaporator Fan will remain on at all times that the Compressor is energized.

11:53 AM 11 Jan 2013

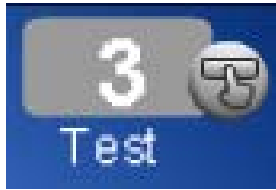

Test Menu

SureVend Calibration

Press 7 to view
SureVend Calibration

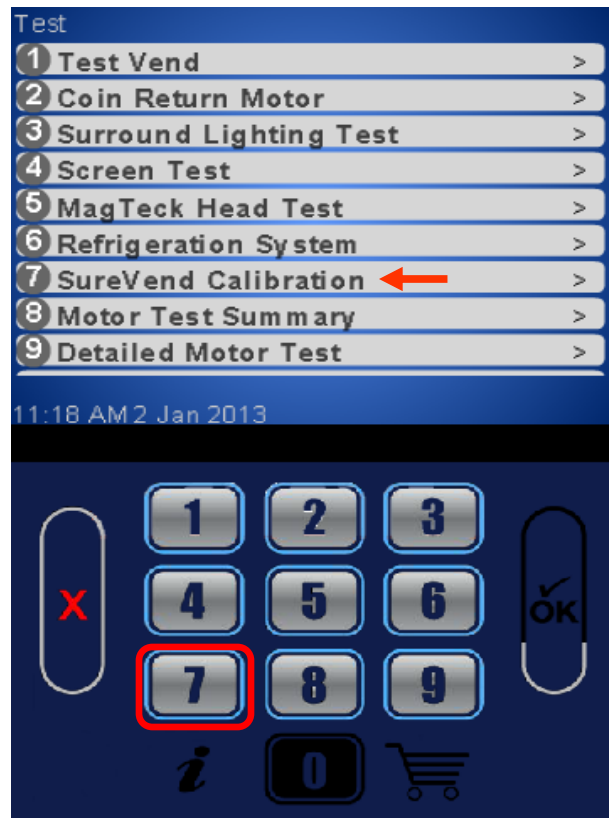

Number 1 is the sensor closest to the trays. Number 9 is closest to the glass. Fours, fives and sixes are all good. When you get a reading above 10, this indicates a partial blockage. Zero indicates a complete blockage or bad sensor.

Sensor number Calibration

| Sensor number | Calibration |
|---------------|-------------|
| 1 | 4 |
| 2 | 4 |
| 3 | 4 |
| 4 | 4 |
| 5 | 4 |
| 6 | 4 |
| 7 | 5 |
| 8 | 5 |
| 9 | 4 |

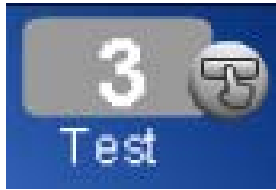

Test Menu

Motor Test Summary

Press 8 to view Motor Test Summary

- 1 = Number of Homed Motors
- 2 = Number of Motors seen by the controller
- 3 = Number of motors present but not at home
- 4 = Press to home all un-homed motors

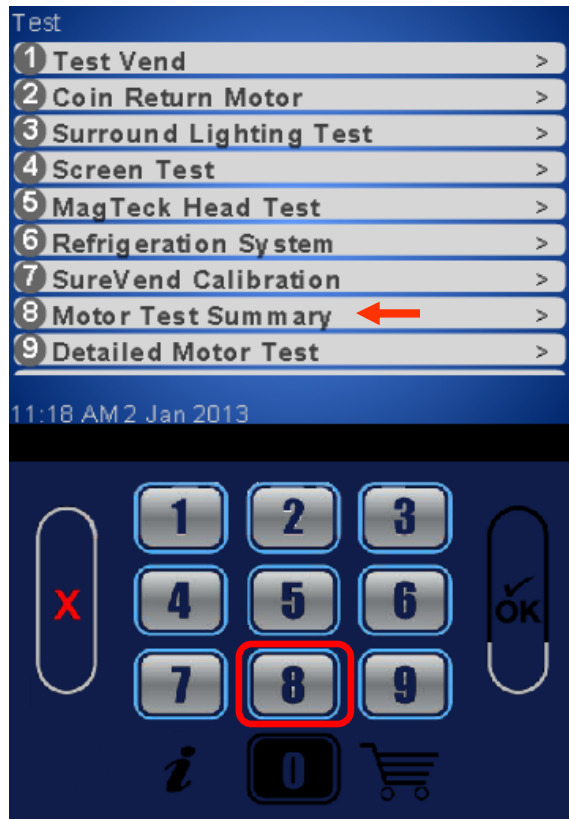

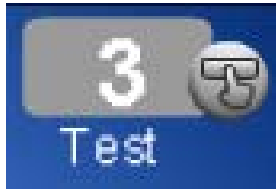

Test Menu

Detailed Motor Test

Press 9 to go to
Detailed Motor Test

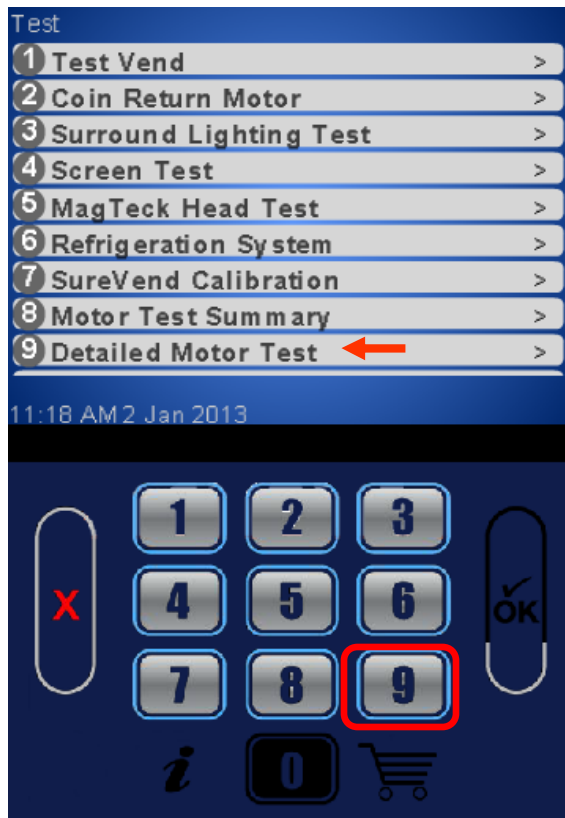

Select the tray you
wish to view



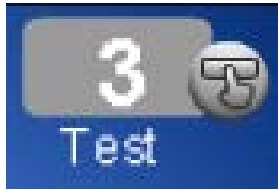

Test Menu

Detailed Motor Test

- **“H”** indicates that spiral is homed
- **“X”** indicates the spiral is present, but not configured
- **“F”** indicates spiral is a FIFO member
- **“C”** indicates spiral is coupled
- **“ERR”** indicates error is present for the spiral.
- **“W”** indicates spiral is a Winner member, Token member or a Combo member.
- **“T”** indicates spiral is a Time of Day event member.

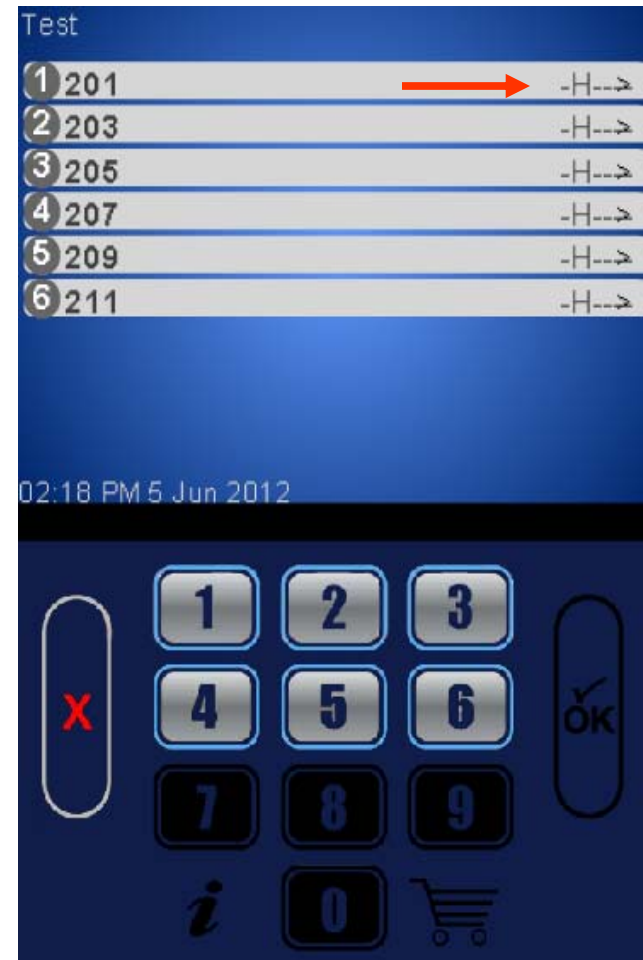

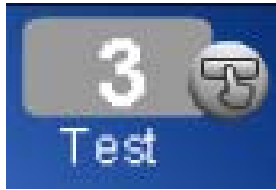

Test Menu Light Relay

Press the highlighted lower half of the OK button to scroll down to Relay Test

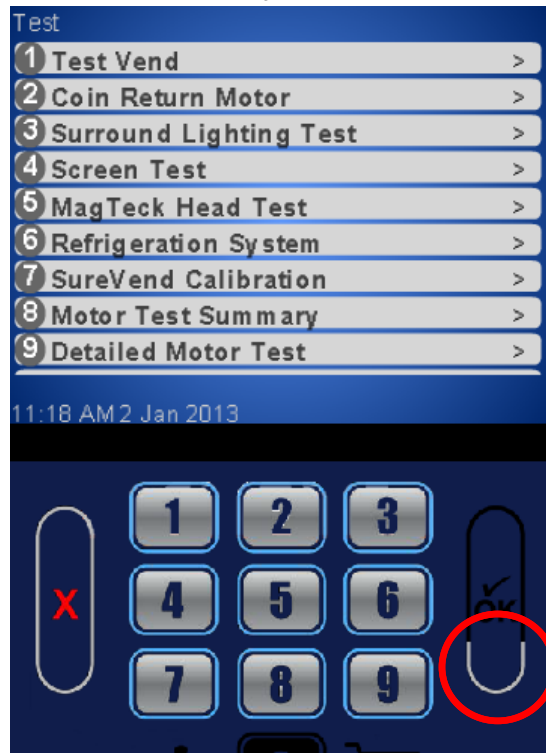

Press 2 to access Light Relay test

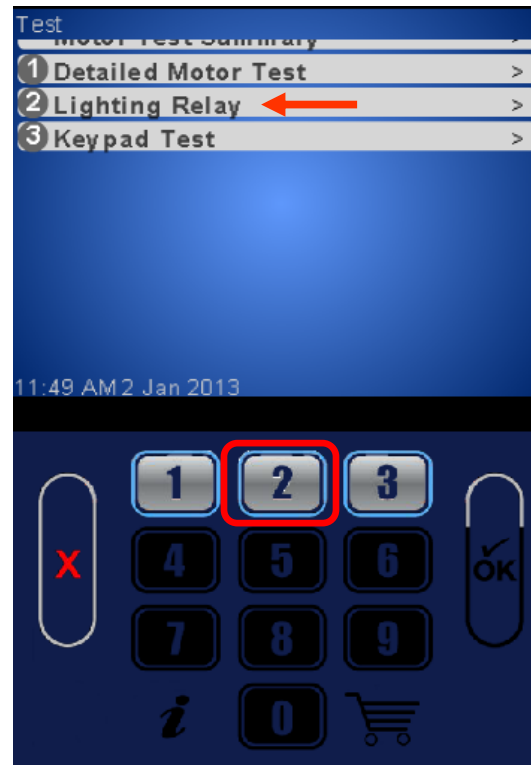

Press 1 to toggle cabinet lights off and on



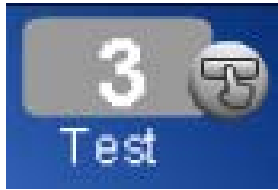

Test Menu

Keypad Test

Press 3 to enter
Keypad Test

The first highlighted key will be the upper half of the X key, once pressed the number 1 key will light. Continue pressing the highlighted keys in sequence until all keys have been tested. Press X at any time to exit.

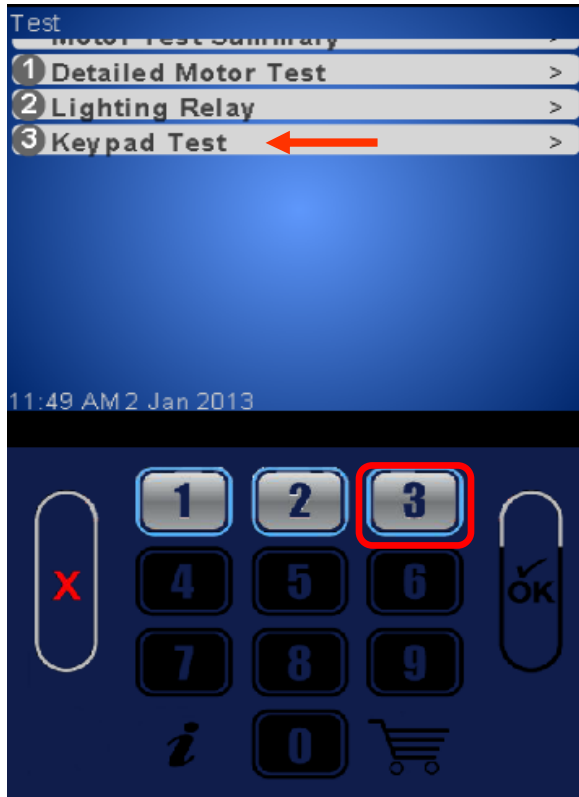

Press the Highlighted key

Press X to exit



Price Menu

Price Menu

Provides Access to Price setting options.

- Press number 4 on the keypad to access the Prices.

There are three options for setting prices:

- By Tray
- Entire Machine
- Individual Prices





Price Menu

Setting Prices by Tray

Setting Prices by Tray

- Choose tray you want to Price
- Enter the price for that tray and press OK.





Price Menu

Setting Entire Machine Prices

Entire Machine Pricing

- Press 5 to set the Entire Machine to one price.
- Enter the price desired and press OK.

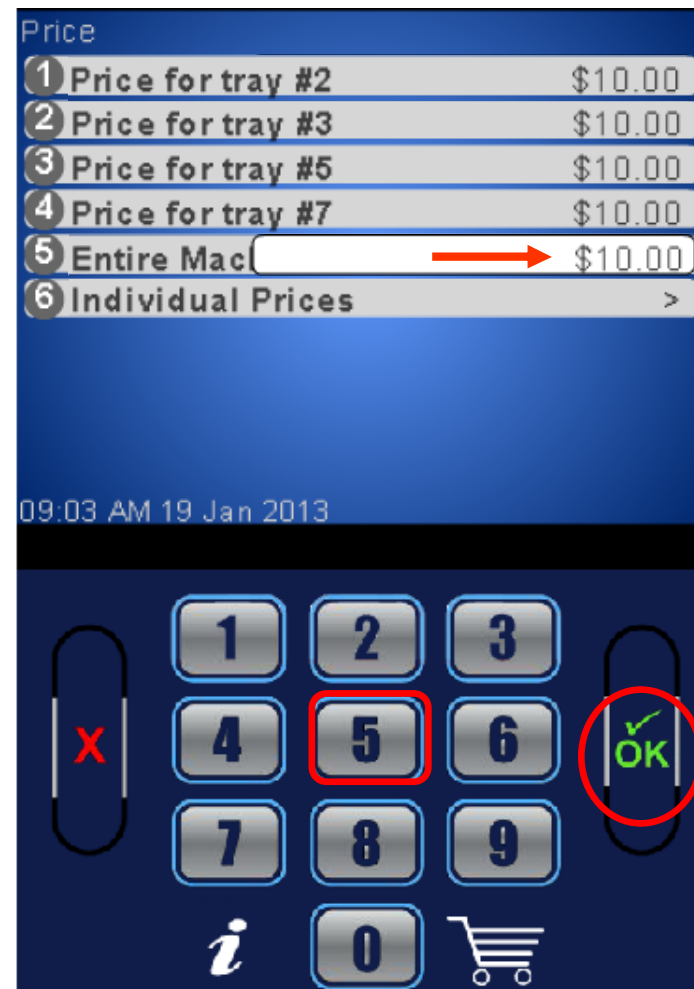



Price Menu

Setting Individual Prices

Individual Prices

Choose number one on the keypad to set individual prices.

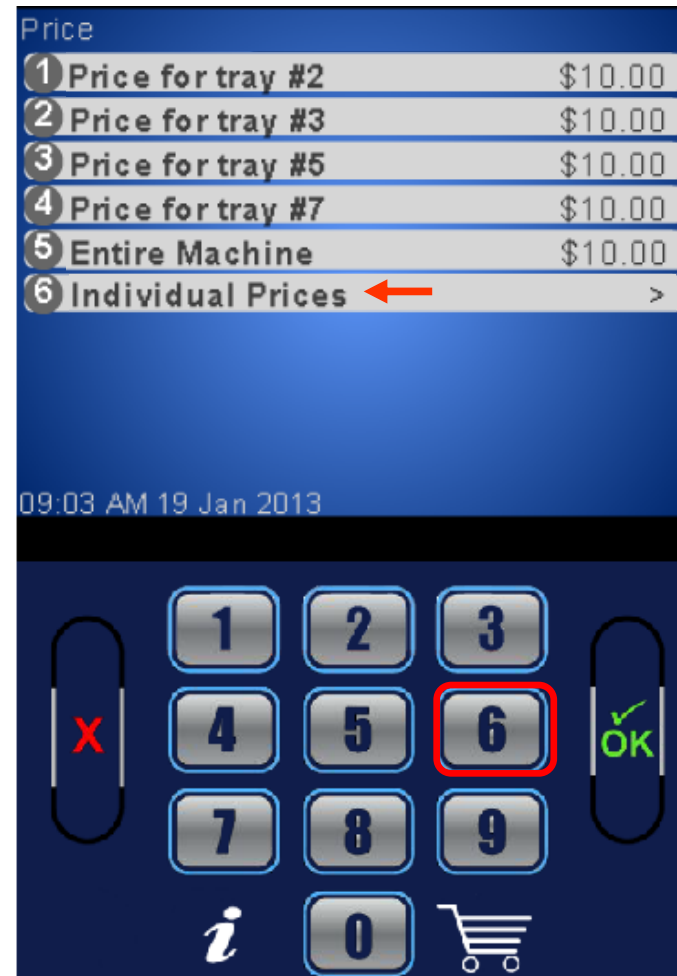



Price Menu

Setting Individual Prices

Step 1 –
Chose a Tray first



Step 2 –
Chose a Selection

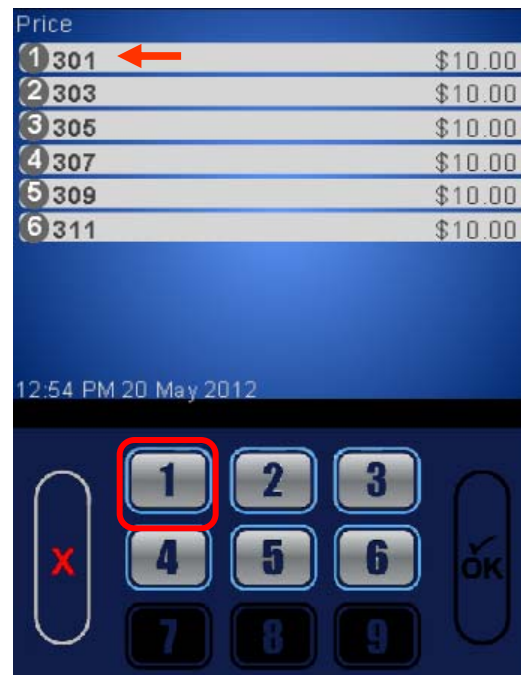

Step 3 –
Enter desired price
and press OK





Product Configuration

- The Product Configuration menu provides access to the following modes in the machine:
 - Selection Configuration
 - FIFO Setup
 - UPC Setup (package UPC)
 - Shopping Cart Setup
 - View Planogram
 - Couple Motors
 - SureVend





Product Configuration Selection Configuration

Press 1 to enter the Selection Configuration Menu.

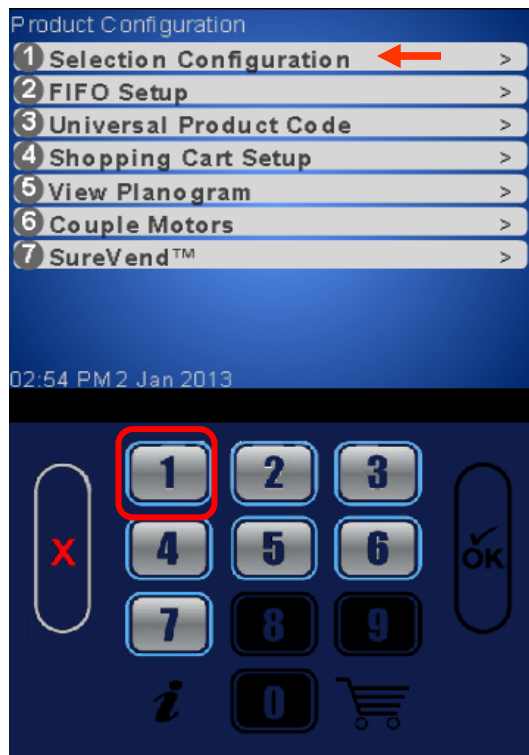

Press 1 to Auto Configure the motors.

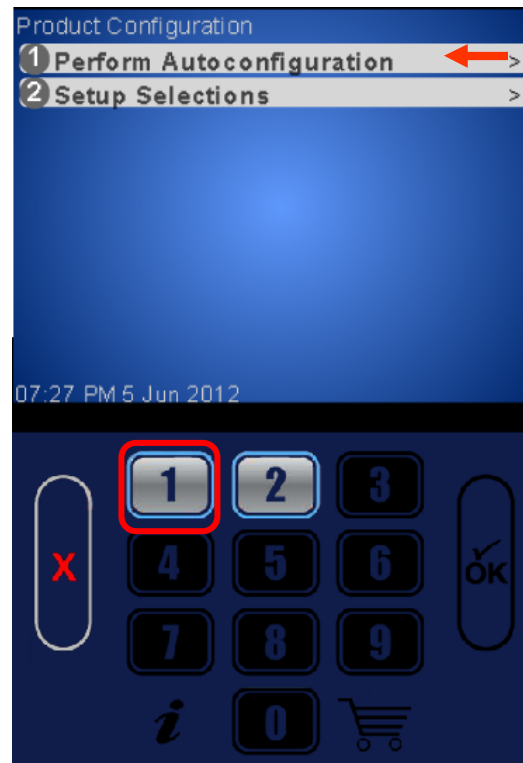

The controller will scan all the motors and automatically enable all motors that are detected.



Selection Configuration – Set Up Selections

Press 2 to manually configure selections.

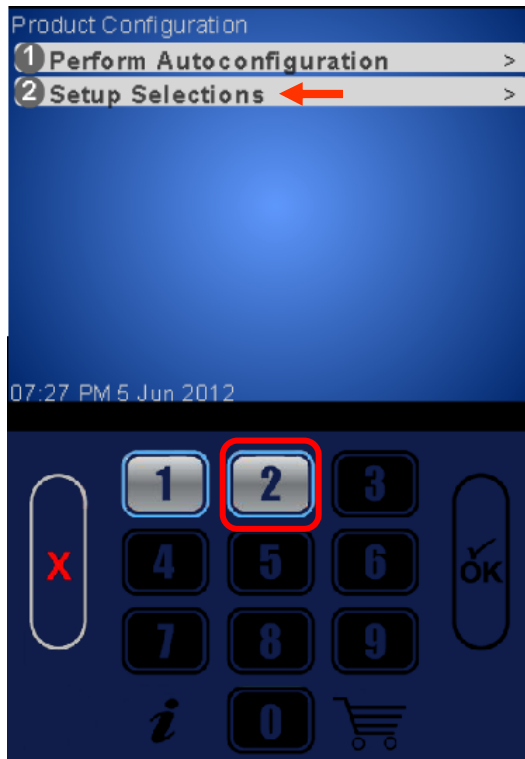

Select the desired tray to view or change the enabled selections. Disabling a selection can be used where a bad selection motor is present

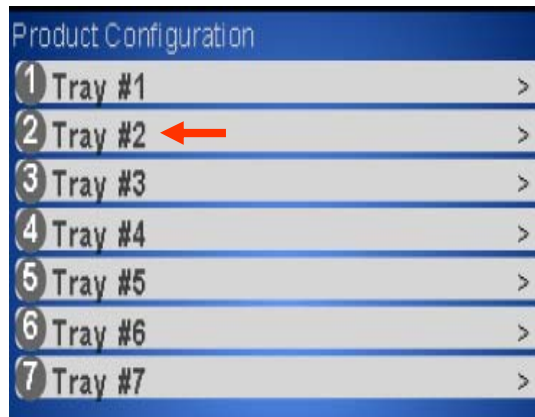

Use the keypad to add or remove a checkmark. Motors with a checkmark will be enabled and part of the configuration. In some cases the bottom of the OK button will be lit to scroll to additional selections.



FIFO (First In, First Out)

- **FIFO** (First In, First Out) allows you to program your machine to run multiple selections as a single selection.
- No matter which selection ID of the group is entered, the Merchant™ will vend round-robin from the group of spirals, skipping selections that are out-of-service.
- This feature can provide a First-In-First-Out for perishable foods.
- It also helps to prevent one spiral of duplicate selections to go empty before the others of the same selection.
- **Note: Ensure that all selections chosen for each FIFO group are the same price. If not, the machine will price all selections to the highest price in the group.**



Product Configuration

FIFO Continued

The FIFO menu allows you to:

- Add a Group
- Delete a Group
- Edit a Group
- View Existing Groups (Mappings)



Product Configuration

FIFO – Add a Group

Press 1 to Add a FIFO Group



Select the desired tray to view or change the enabled selections.

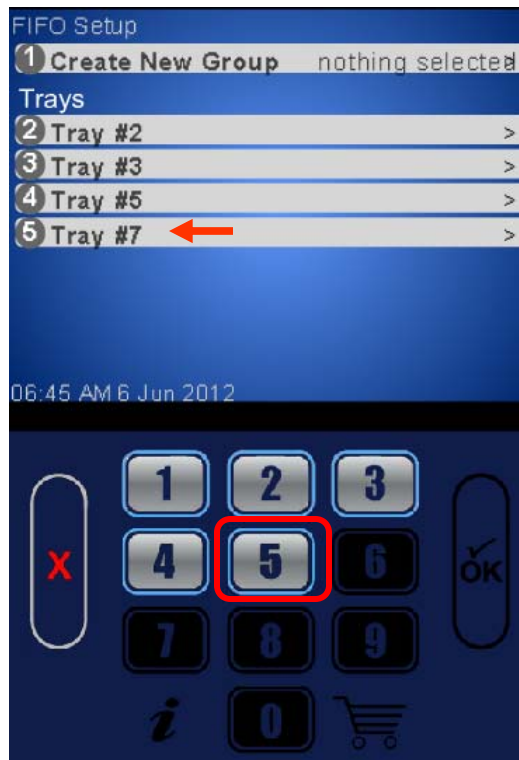

All available selections are shown. Press the keypad to add a checkmark to the motors to be configured.

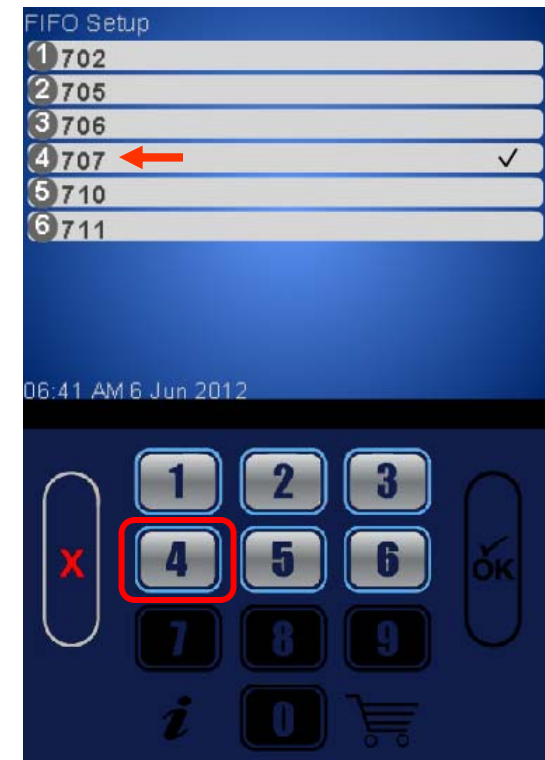

Product Configuration

FIFO – Delete a Group

Press 2 to Delete a
FIFO Group



Select the desired Group to
be Deleted and press OK



Press 1 to confirm or 2
to back out

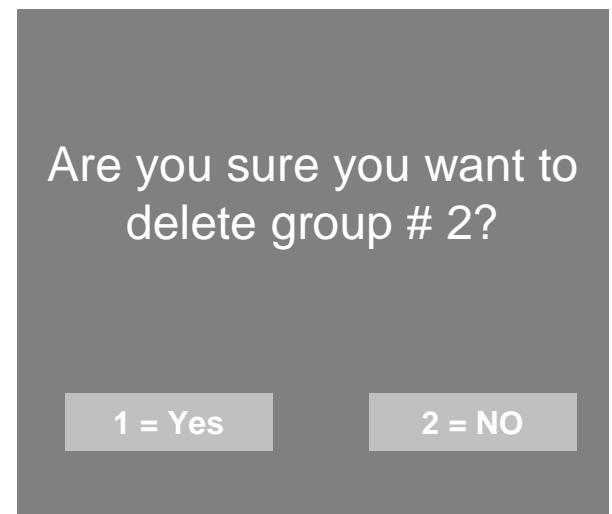

Product Configuration

FIFO – Edit a Group

Press 3 to Edit a FIFO Group



Select the desired group to Edit.



Product Configuration

FIFO – Edit a Group

Select the tray you wish to Edit



Use the keypad to check or uncheck a selection from the group. Press X to exit

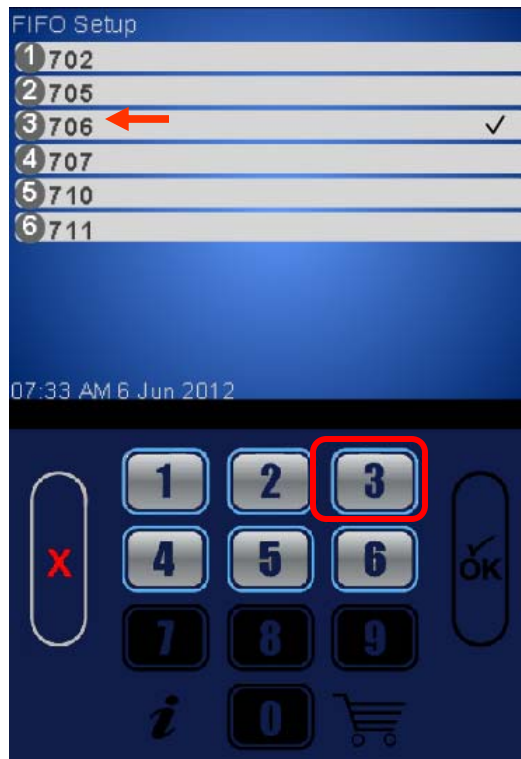

Be sure to save the changes by pressing 1



Product Configuration

FIFO – Mappings

Press 4 to for current FIFO Mappings.



Select the desired tray to View current mappings.



The display shows the current Mapping for the motors on the tray selected.



5
Product Configuration

Product Configuration

Universal Product Code

Select the tray the product is on that you want to view or change.

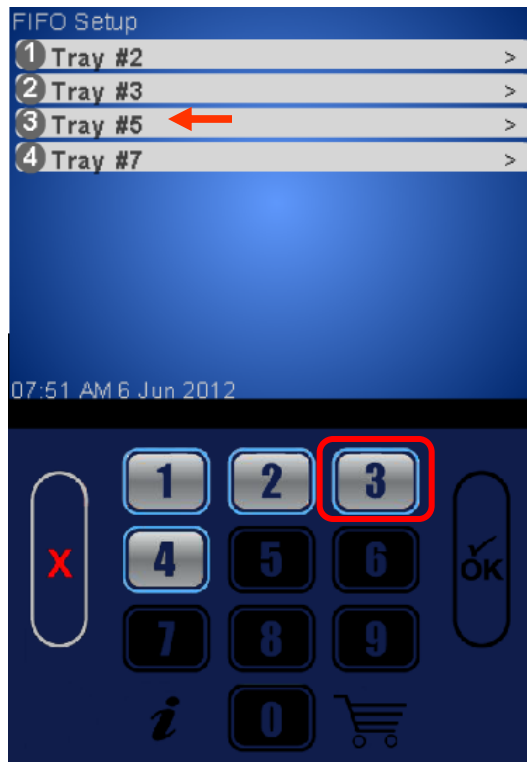

The display shows the current 12 digit UPC assigned to the selections, choose the selection you wish to change

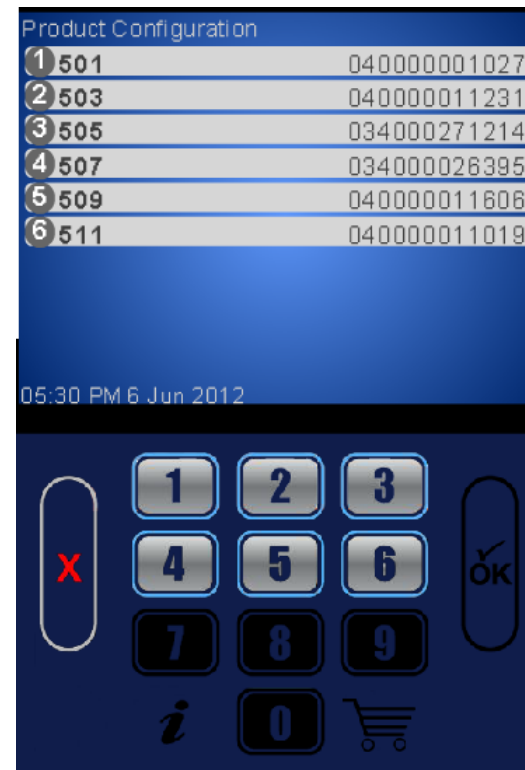



Product Configuration

Universal Product Code

- For a UPC code to be valid, The UPC Code must have been on you Flash drive when the Planogram was uploaded to the machine.
- Deleting a UPC Code will cause that selection to show a generic picture on the display and no nutritional information will be available for that selection.
- You can use the same UPC Code for multiple selections if you want two or more selections of the same product.
- Use the Numeric Keypad enter the 12 digit UPC code you wish to add.
- The shopping cart on the bottom right serves as a backspace key.
- Press OK to save.

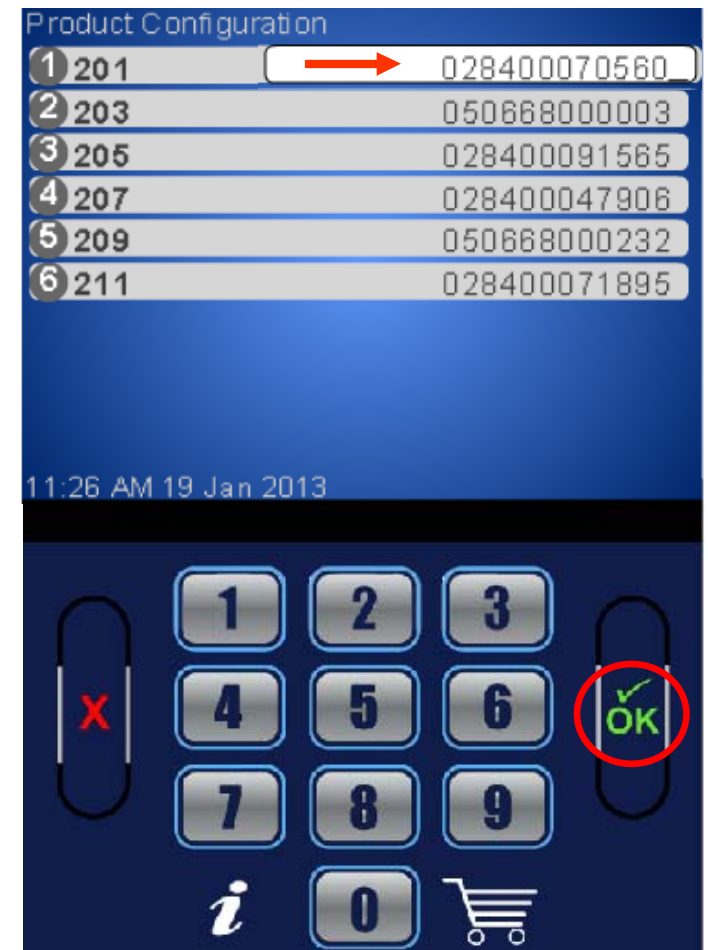

5 Product Configuration

Product Configuration Shopping Cart Setup

- This menu provides access to set up the Shopping Cart.
- Shopping Cart permits the user to select multiple items, and place them into a virtual “Shopping Cart” and to purchase them using a single financial transaction.
- Recommended Shopping Cart size is 3 items.
- The Maximum Shopping cart size allowed is 3 on the Keypad version.
- Max Fund amount can be roughly calculated by multiplying the highest vend price in the machine times the Shopping Cart size.

Note: When Rapid Vend is turned on in under the Special Vend Mode the shopping Cart is automatically disabled.

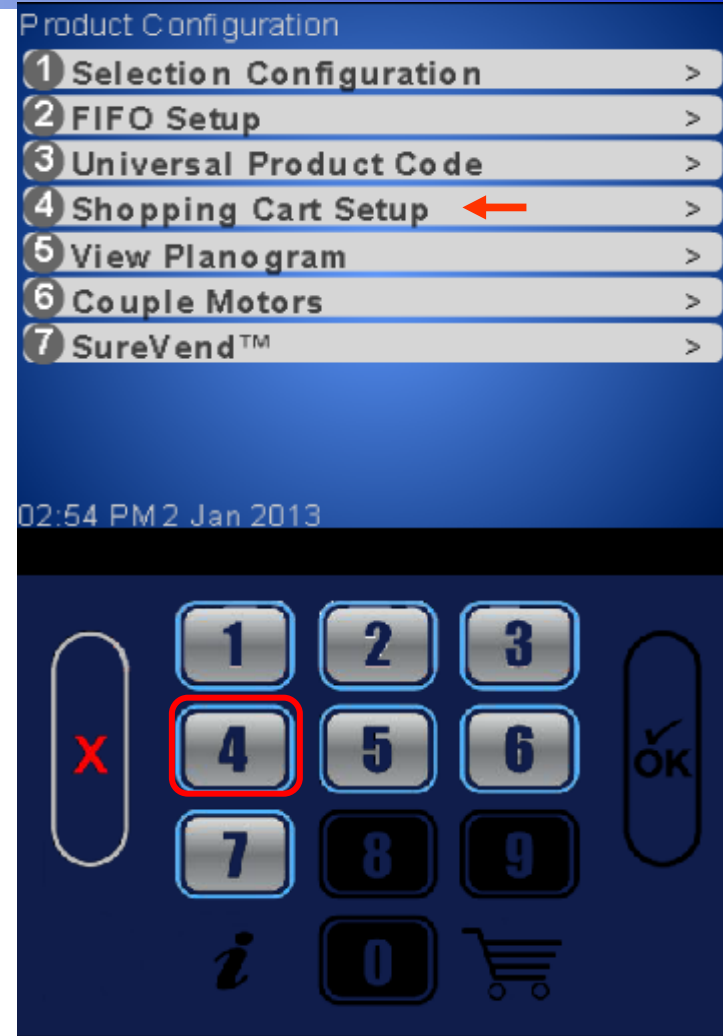

Continued →

5 Product Configuration

Product Configuration Shopping Cart Setup

Select 1 to change the maximum number of items in the cart, 3 is recommended. Press X to exit

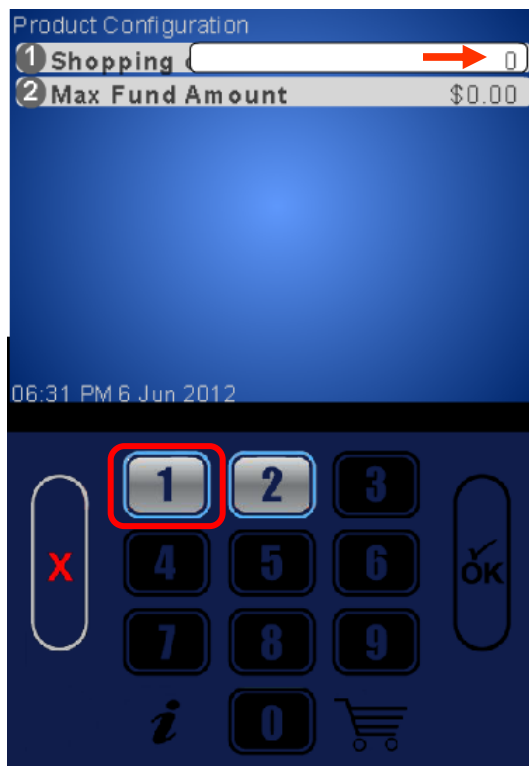

Select 2 to change the maximum amount of funds in the cart, We recommend the cart size times the highest vend price. Press X to exit





Product Configuration

View Planogram

To View the existing Planogram Press 5



Select a tray to view the existing Planogram



If a Planogram has been loaded into the machine, a picture of the product for each selection will be shown. If not a generic picture will be shown





Product Configuration

Couple Motors

Press 5 to enter the Product Configuration Menu.



Press 5 to enter the Couple Motors Menu.

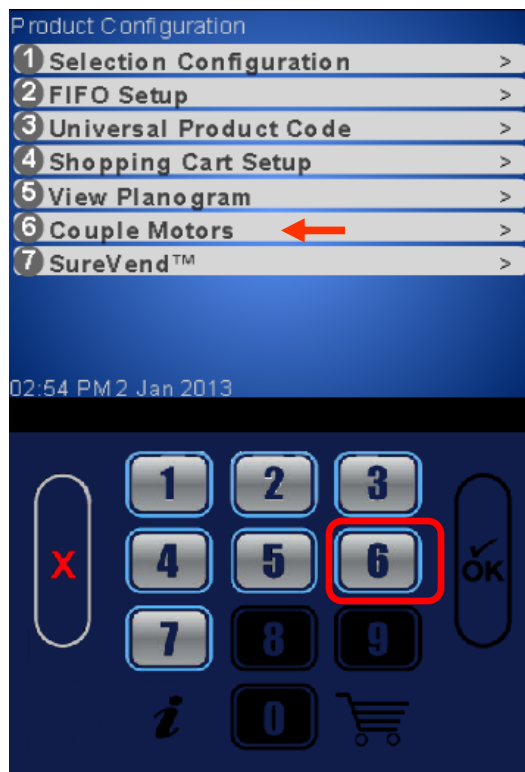

All available selections that can be coupled are shown. Use the keypad to add a checkmark to the selections to be coupled.

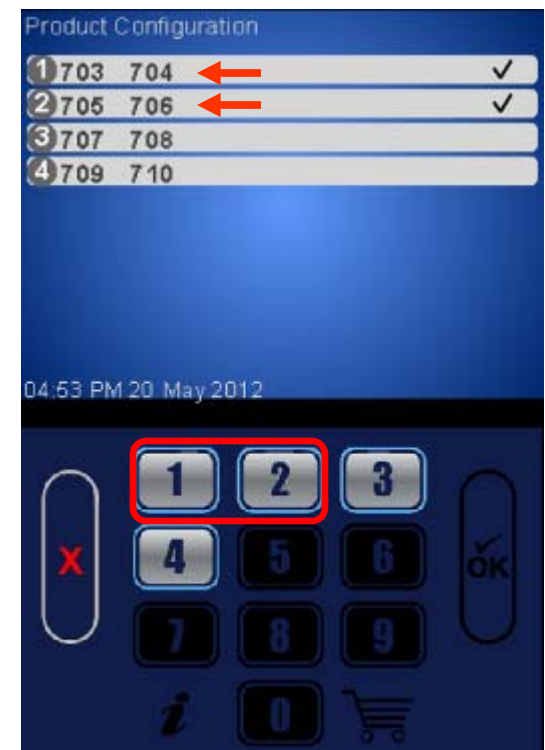



Product Configuration

SureVend™

SureVend™

- The SureVend™ Bin Sensor ensures a positive vend every time.
- The sensor is installed in the delivery bin and senses that a product has been delivered.
- If no product was delivered, the spiral will make up to two (default setting) additional turns.
- If the product is not delivered after three attempts, the machine will allow the customer to make another selection or press the coin return and receive their change back.

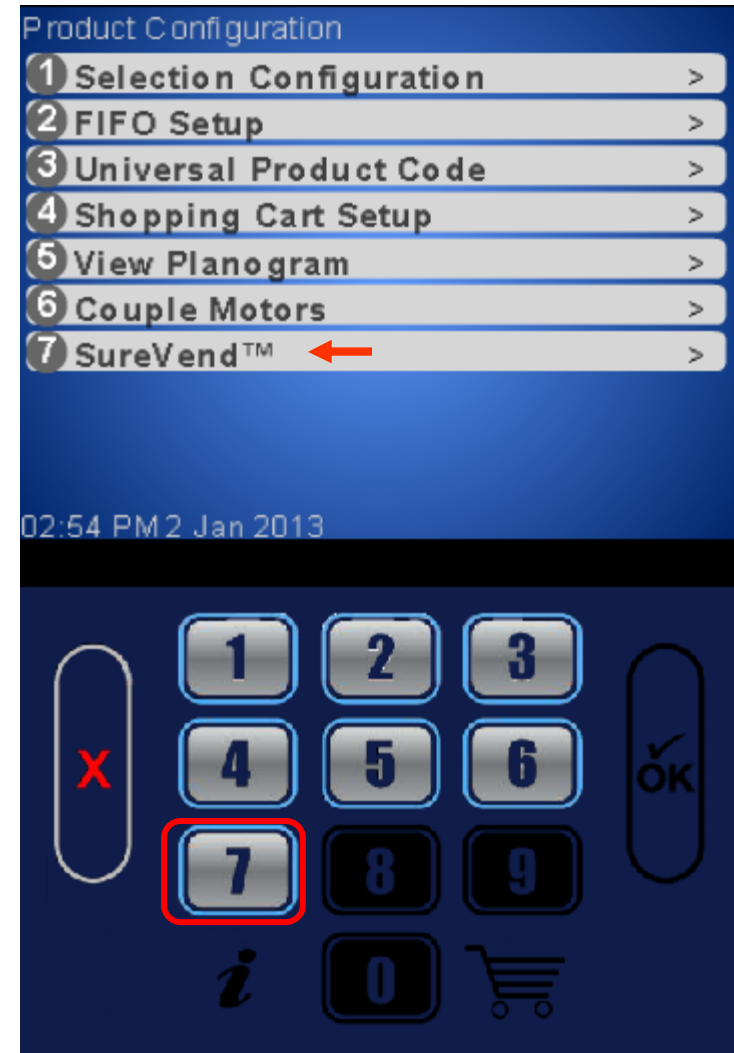

Press 1 to toggle the current state between on and off.

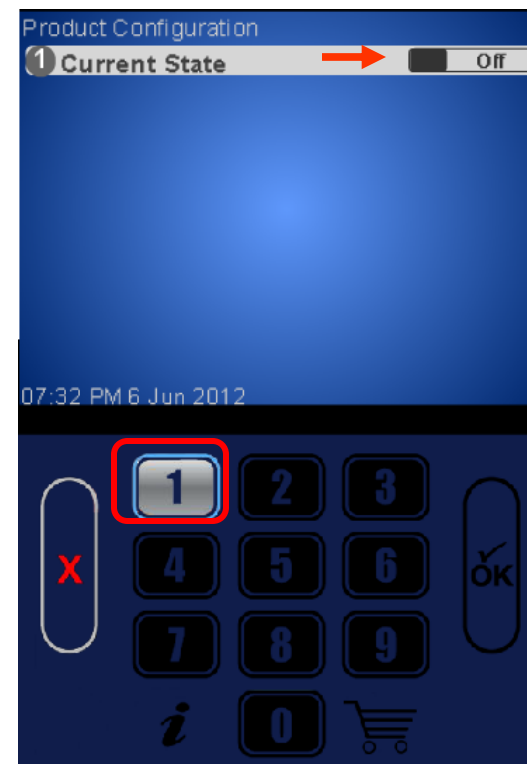

Press 2 to toggle between Must Surevend and Optional SureVend™

1= Options SureVend™, if the SureVend™ stops working the machine will stay in order and the spiral will turn only once.

2 = Must SureVend™, if the SureVend™ stops working the entire machine will go out of service.

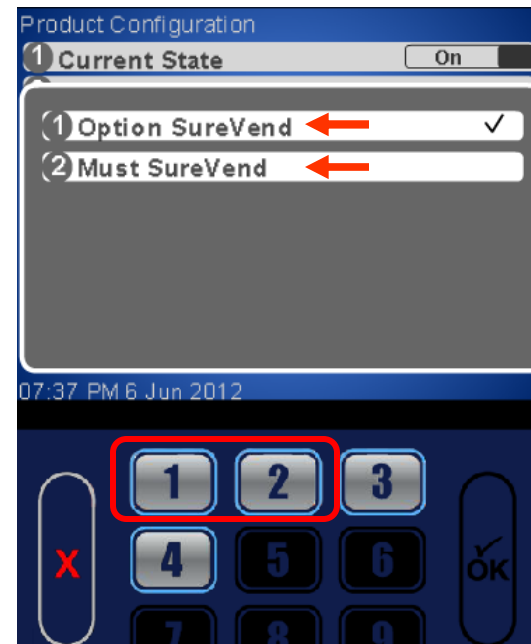
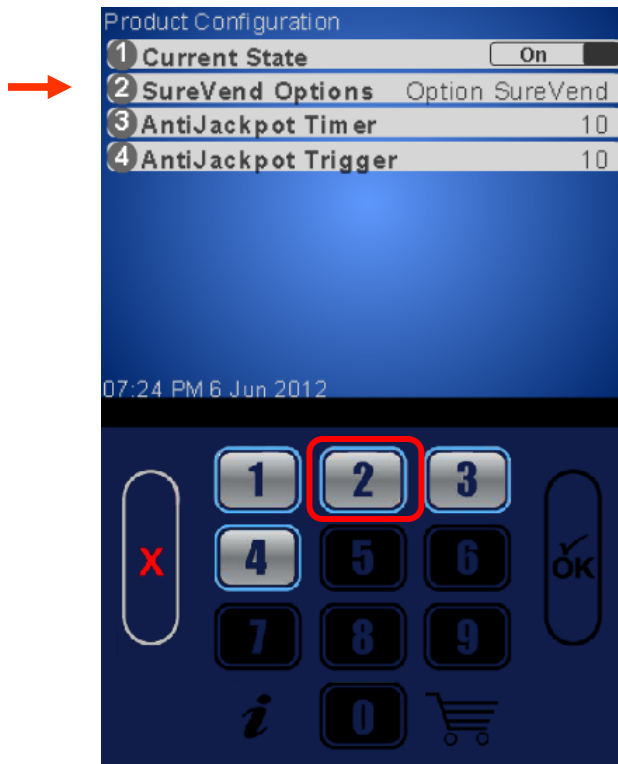

Continued →

5 Product Configuration

Product Configuration SureVend™

Press 3 to change the Anti-Jackpot timer, the default time is 10 minutes

Use the Keypad to enter a new time (in minutes) and press Ok. If a spiral turns 3 times and no product is detected by the SureVend™ that selection will be unavailable for the period of time set. After the time is expired, the selection will be available for purchase again, The SureVend™ will protect the customer from loosing money during this time.

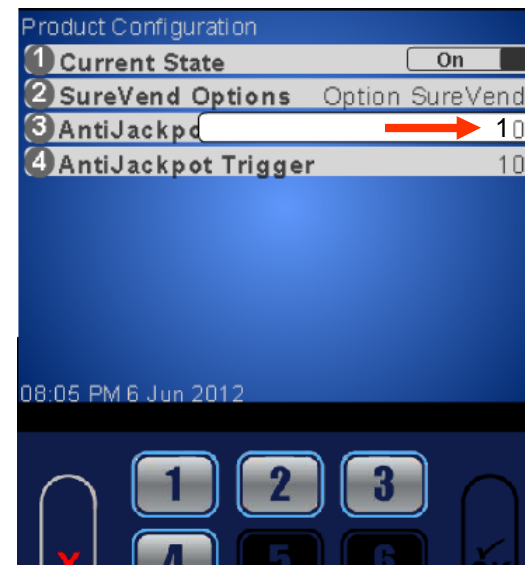

5 Product Configuration

Product Configuration SureVend™

Press 4 to change the Anti-Jackpot Trigger, the default is 2.

The Anti-Jackpot Trigger is how many additional turns the spiral makes if a product is not seen by the SureVend™ sensors on the first turn. The default setting is 2. Use the keypad to enter the new setting and press OK.

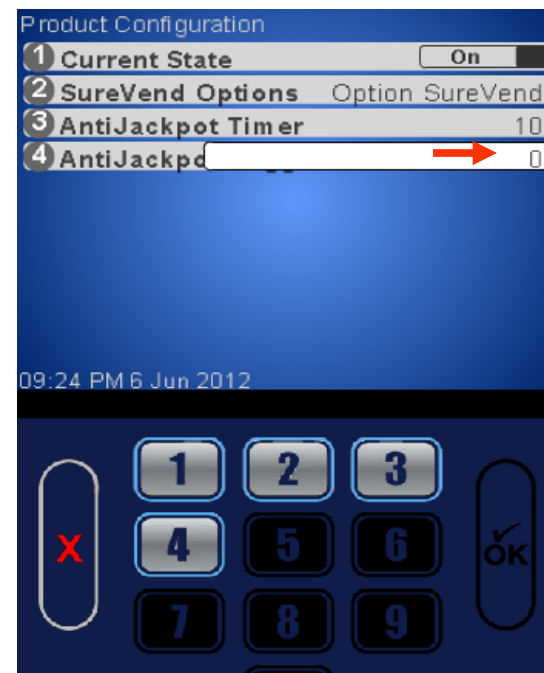
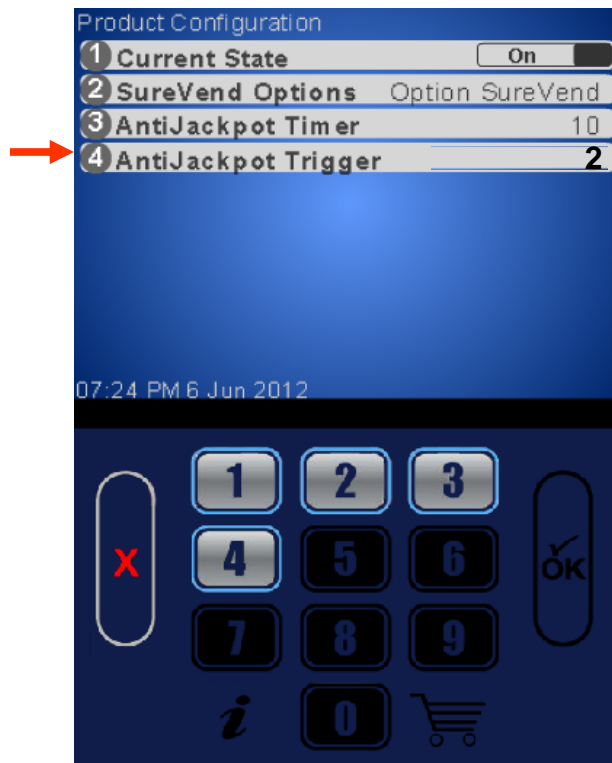



Special Vend Modes

Special Vend Modes provides access to:

- Free Vend
- Winner Mode
- Combo Vend
- Token Enable
- Rapid Vend

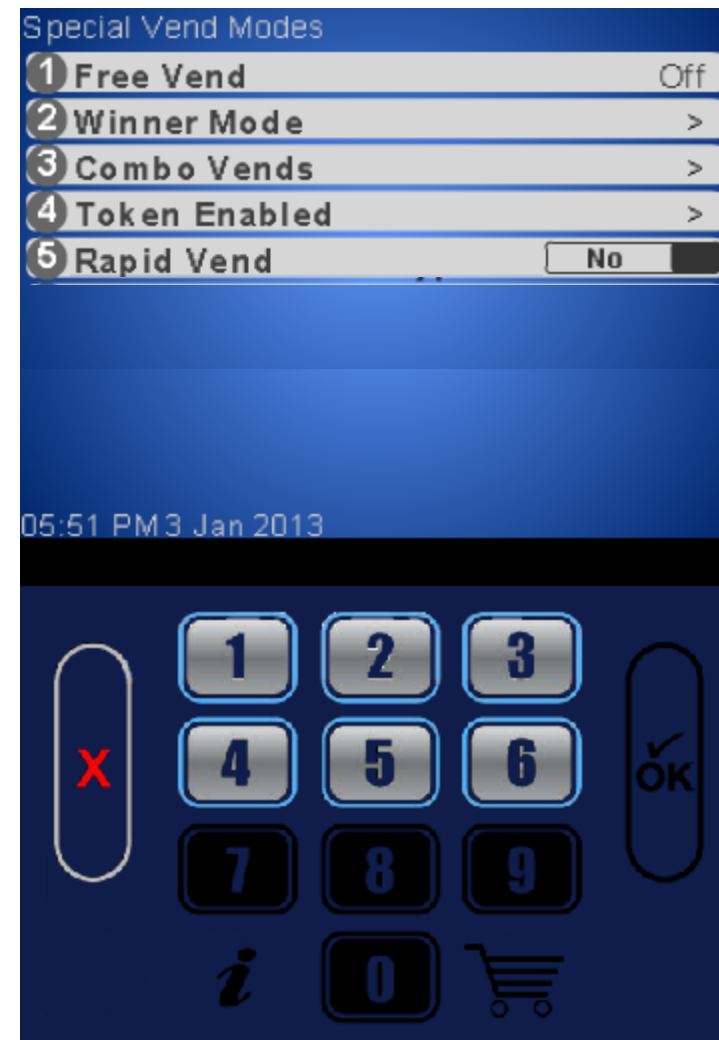



Special Vend Modes

Free Vend

Free Vend

- Press 1 to toggle the free vend setting between OFF and ON.
- When set to ON all items will be free until turned off.

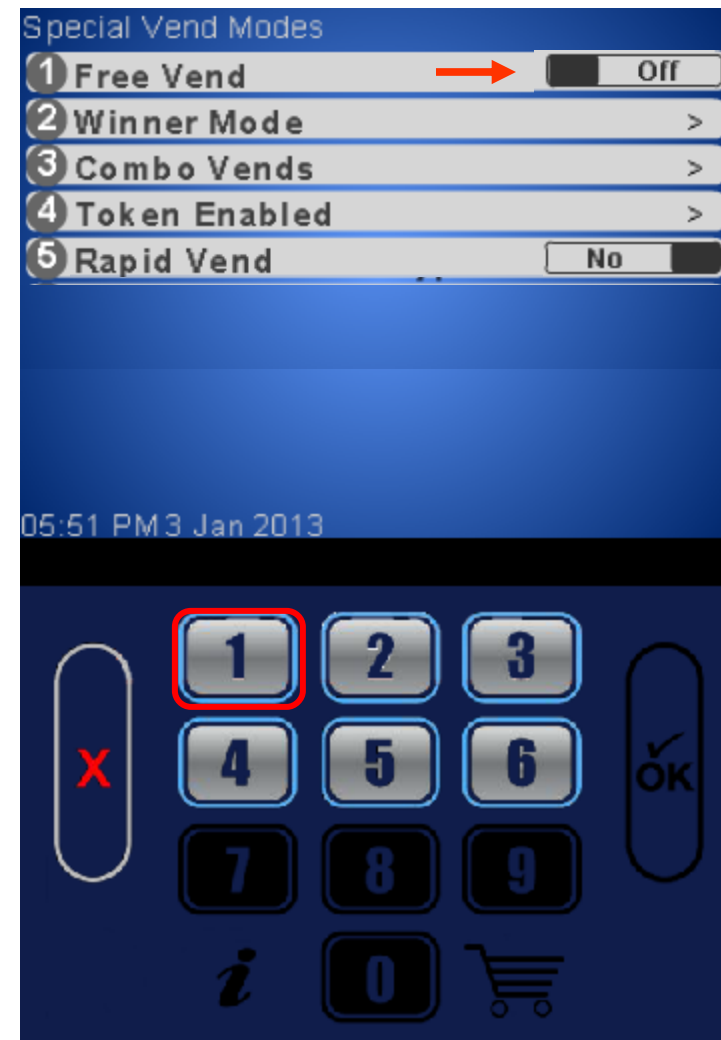



Special Vend Modes

Winner Mode

Winner Mode

When Winner Mode is turned on:

- The customer will receive their product and get their money back or an additional item (programmable).
- The display will prompt the customer that they are a winner.
- The frequency of a winner is programmable.

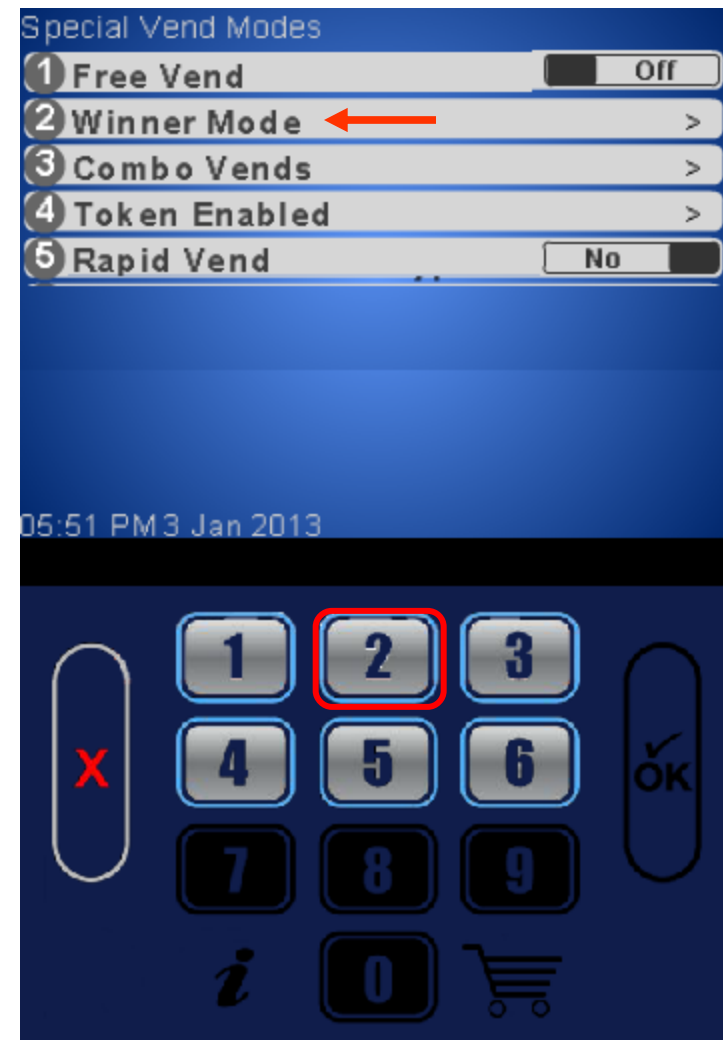



Special Vend Modes

Winner Mode

By choosing 1-4 on the keypad you can:

1 – Add a Group

2 – Delete a Group

3 – Edit a Group

4 – View the current selections assigned to a Winner Group





Special Vend Modes

Winner Mode – Add a Group

Adding a New Winner Group:

- To add a New Group you must first set the Parameters 2-4 and the choose the selections that are to be part of the group. Once selections are set, press 1 to add a new group.

Note: You will not be allowed to add a new group without setting selections first.



6
Special Vend Modes

Special Vend Modes

Winner Mode – Add a Group

Press 2 to toggle between Prize and Winner. If set to Winner the customer will receive their money back based on the frequency set

If set to Prize another menu item (4) will appear on the display. This is where you will choose the item the customer will win based on the frequency set.

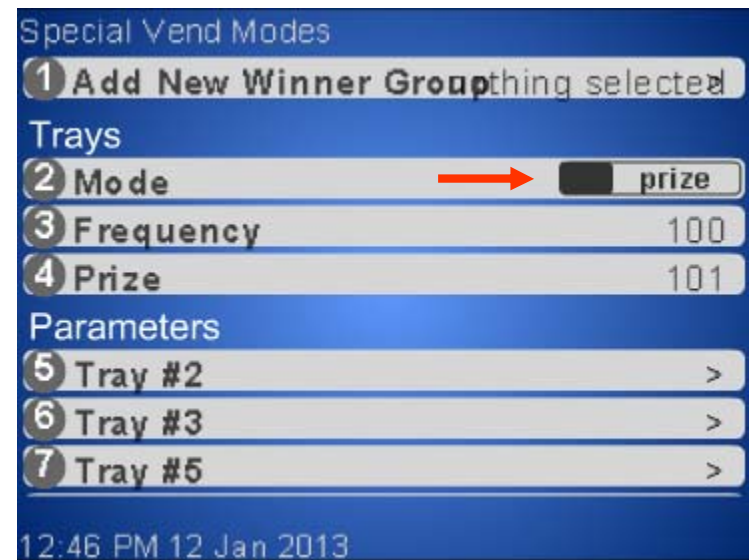
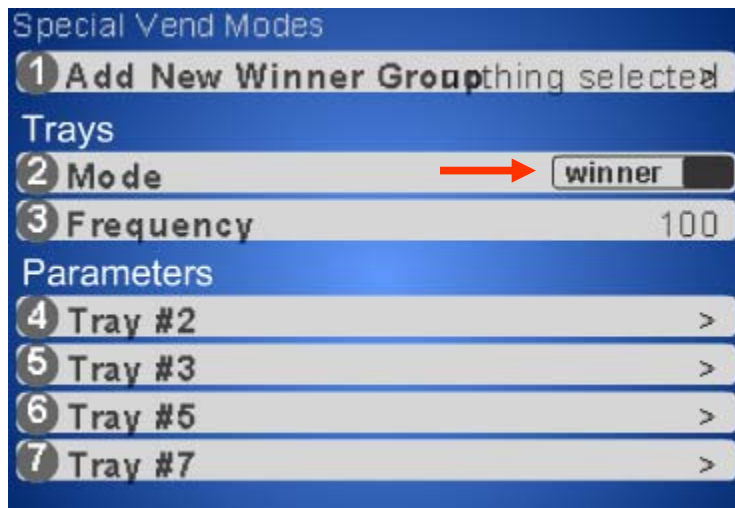



Special Vend Modes

Winner Mode – Add a Group

Choose number 3 to choose how often a customer will be a winner.

Use the keypad to enter the Frequency of a winner and press OK..

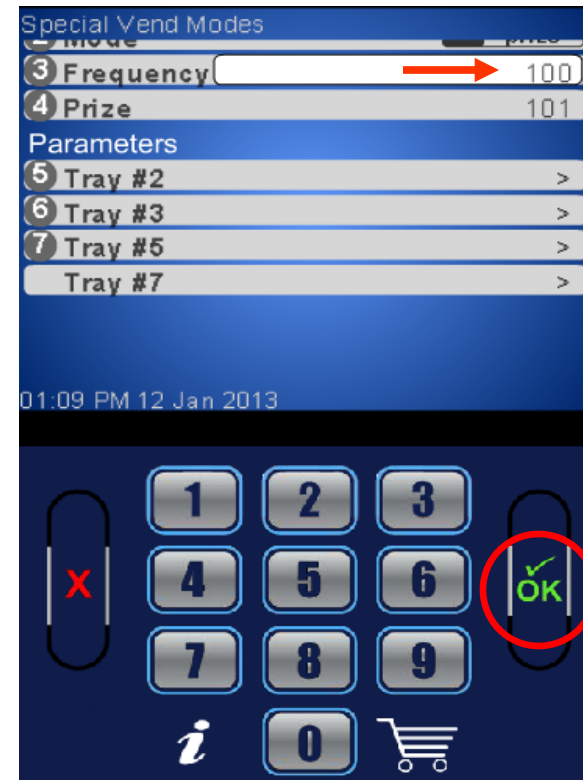
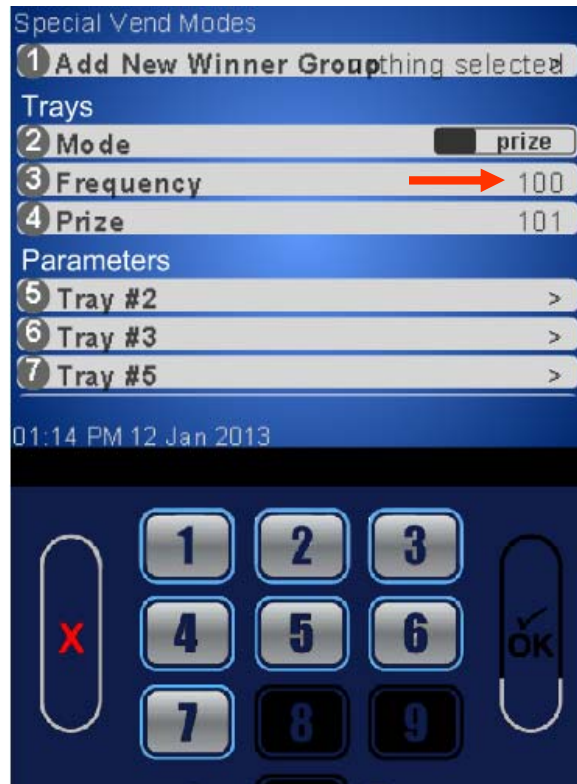



Special Vend Modes

Winner Mode – Add a Group

Select 4 to enter the selection number that will contain the prize. This menu will not be shown if winner was selected instead of Prize

Use the keypad to enter the selection number that will contain the prize and press OK.

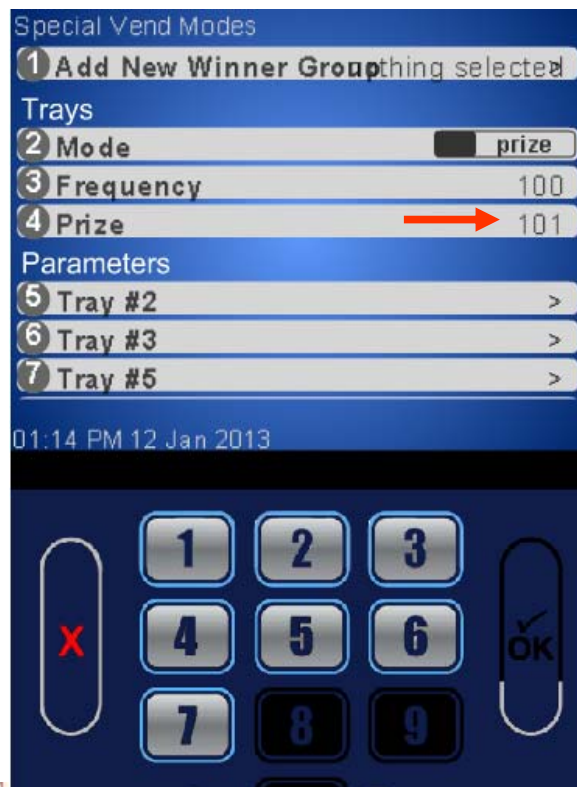

6
Special Vend Modes

Special Vend Modes

Winner Mode – Add a Group

Select the tray you wish to assign selections to work with Winner Mode.

Use the keypad to Select All, Clear All or add a checkmark to the selections to work with Winner Mode. Press the X key to exit and choose another tray to add selections to if desired.

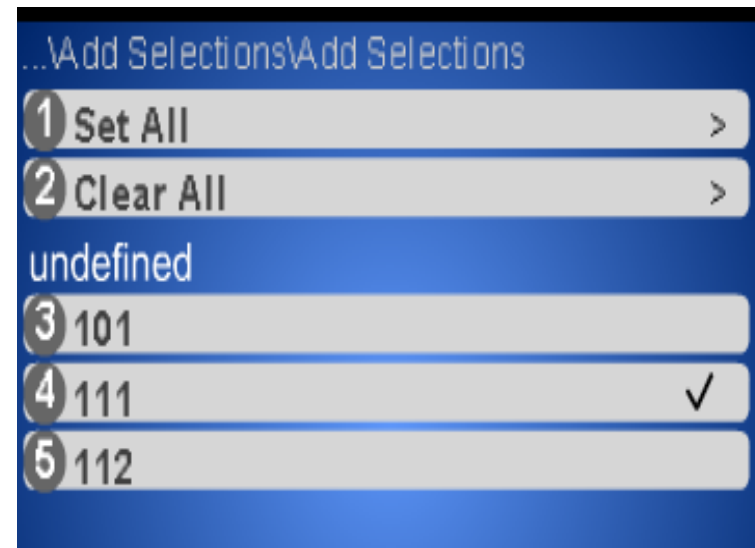
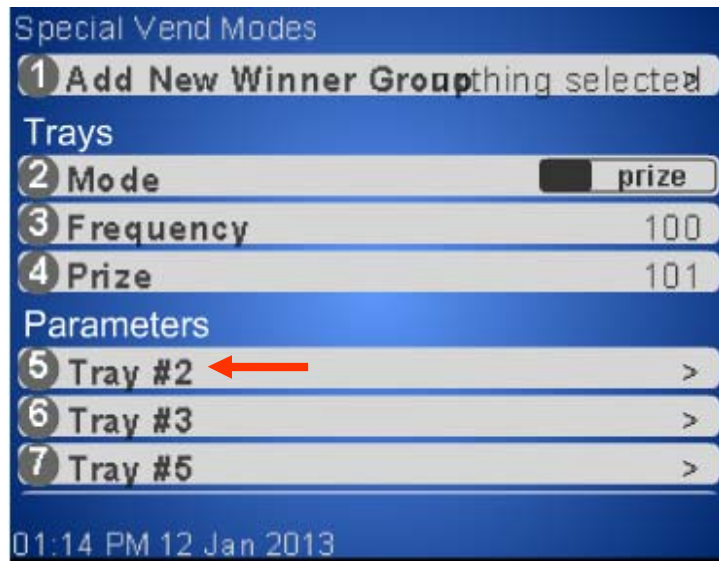



Special Vend Modes

Winner Mode – Add a Group

Save your work!

After entering your Parameters and selections for Winner Mode you must choose 1 to Add New Winner Group. If you do not press 1 before exiting, your settings will not be saved!

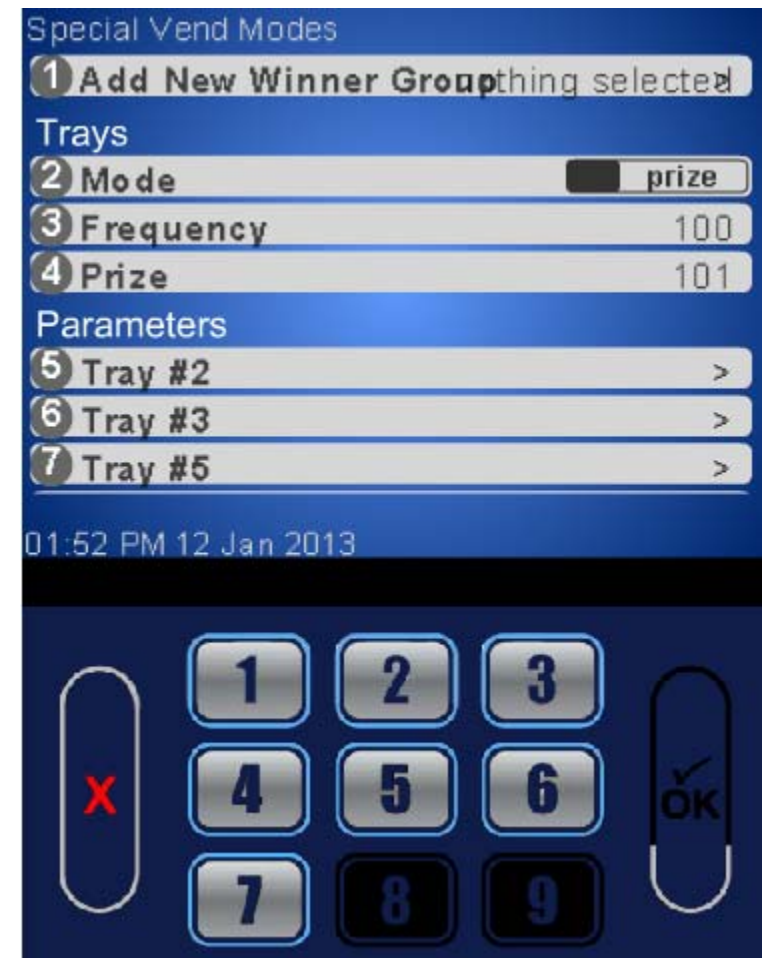



Special Vend Modes

Winner Mode – Delete a Group

Select 2 on the Keypad to Delete a Group

Select the group to Delete and press OK

Press 1 to confirm or 3 to cancel

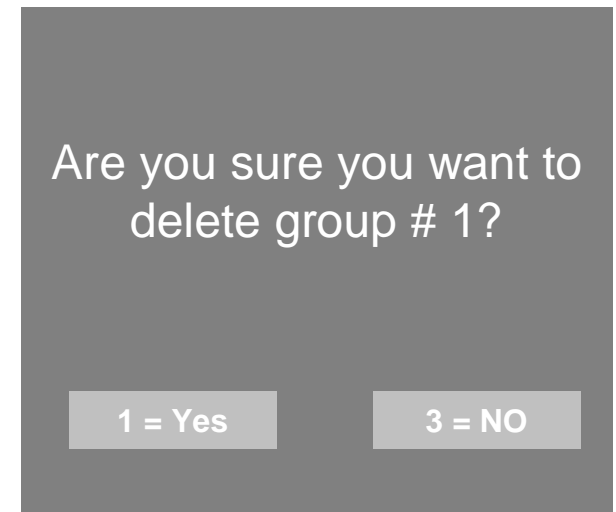

6 Special Vend Modes

Special Vend Modes

Winner Mode – Edit a Group

Select 3 on the Keypad to Edit a Group



Select the group to Edit and press OK



Use the keypad to Select the item you wish to Edit and press OK. **Save the changes when you are done Editing by pressing 1.**





Special Vend Modes

Winner Mode – Winner Selections Assigned

Select 4 on the Keypad to view selections currently assigned to Winner Groups



Select the tray you wish to View



The display will show you what groups each selection on the tray is assigned to





Special Vend Modes

Combo Vend

Combo Vend

- The Combo Vend Menu allows you to set up a selection to be offered in conjunction with another selection.
- A combo vend can be a combination of two or three products.
- All products in a combo vend can be discounted or just the last item.
- Items can be discounted by a value or percentage.
- Press 3 to access the Combo Vend set up mode.



Continued →



Special Vend Modes

Combo Vend

How Combo Vend Works

1. Select the first item and place it in the “Shopping Cart” by pressing the shopping cart icon.
2. Select the second item and place it in the “Shopping Cart”, if a third item is part of the Combo Vend it must be placed in the cart also.
3. Insert money and press OK
4. All items in the cart will be delivered.
5. The discount will be displayed and returned as change.

Rules for setting up Combo Vend

- The rapid vend feature must be set to NO, so that the “Shopping Cart” function is activated.
- Both “Shopping Cart” Value & number of items must be set high enough to accommodate the needs of the Combo Vend Promotion.
- Two items from the same group will not get a discount.
- For two of the same item to be discounted that item must be in group 1 & 2.



Special Vend Modes

Combo Vend

Combo Vend

1. Press 1 to toggle the discount type between value and percentage.
2. Press 2 to add a new Combo Vend.
3. Press 3 to delete an existing promotion.
4. Press 4 to edit an existing promotion.
5. Press 5 to view the existing selection set for a Combo Vend promotion.



Continued 



Special Vend Modes

Combo Vend – Discount Type

Discount Type

- Press 1 to toggle the Discount Type between type between Value and Percentage.
- Based on your selection in this menu the display will say discount percentage or value when you choose the Add New combo Menu.
- You can create & save both Discount and Value promotions but you must come back to this screen to change the discount type before you add a new combo vend if the discount type is different.





Special Vend Modes

Combo Vend – Add a New Combo Vend

Press 2 to Add a new Combo vend promotion

Note: You must set up your combo vend options 2-7 before you can save them by choosing 1 to add a new group. See step by step instructions on the following pages.

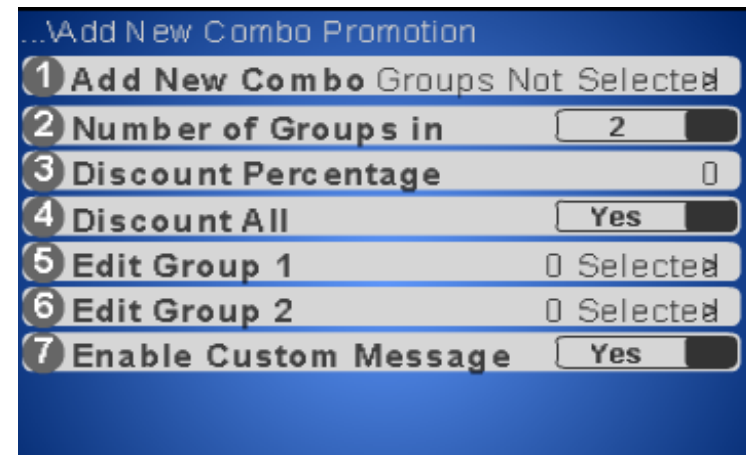



Special Vend Modes

Combo Vend – Add a New Combo Vend

Choose number 2 to toggle the number of items in the combo vend group. You can choose to have 2 or 3 selections as part of a combo vend group. If you choose 3, the customer must buy three items that are part of the group for the discount to apply.

Choose number 3 to set the value or percentage of the discount. The screen will say either discount or value based on your choice of discount type in the previous menu

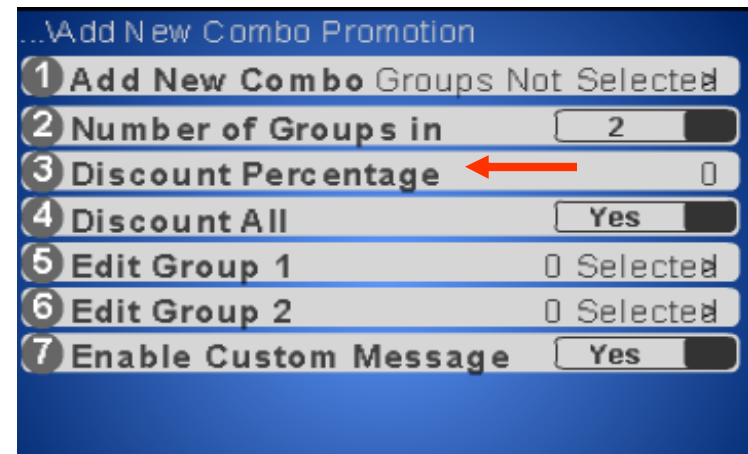
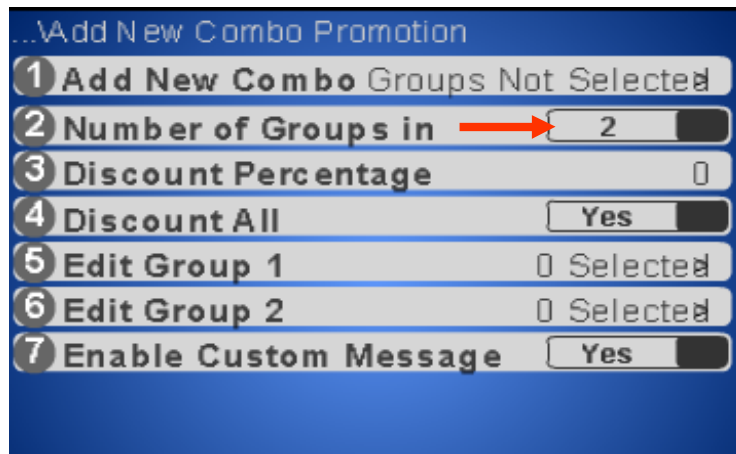



Special Vend Modes

Combo Vend – Add a New Combo Vend

Discount All

- Choose number 4 to toggle discount all between Yes and No.
- If you choose **Yes** all items that are part of a combo vend group will all be discounted by the amount set.
- If you choose **No** only the last item in the discount group will be discounted.

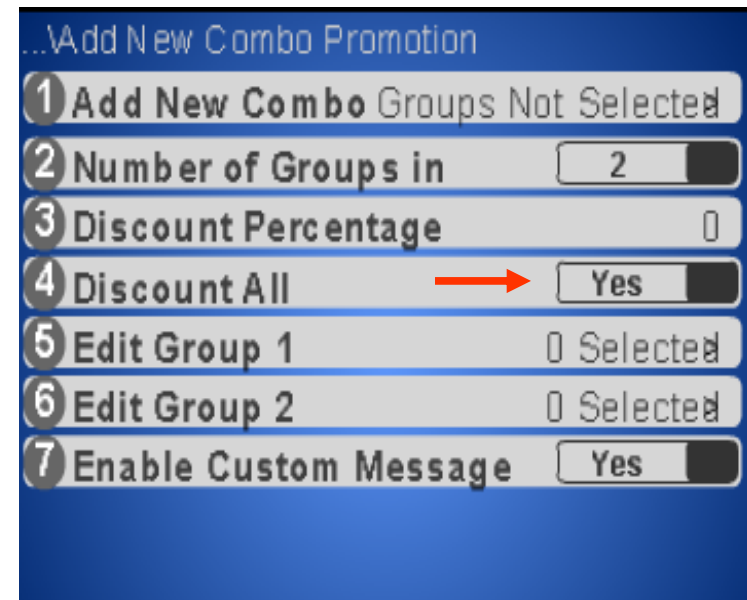



Special Vend Modes

Combo Vend – Add a New Combo Vend

Choose number 5 to set selections for group one, number 6 for group two and number 7 for group three. Group 3 will only appear if the number of groups is set to three.

Choose the tray or trays that contain selections to be added to the group.

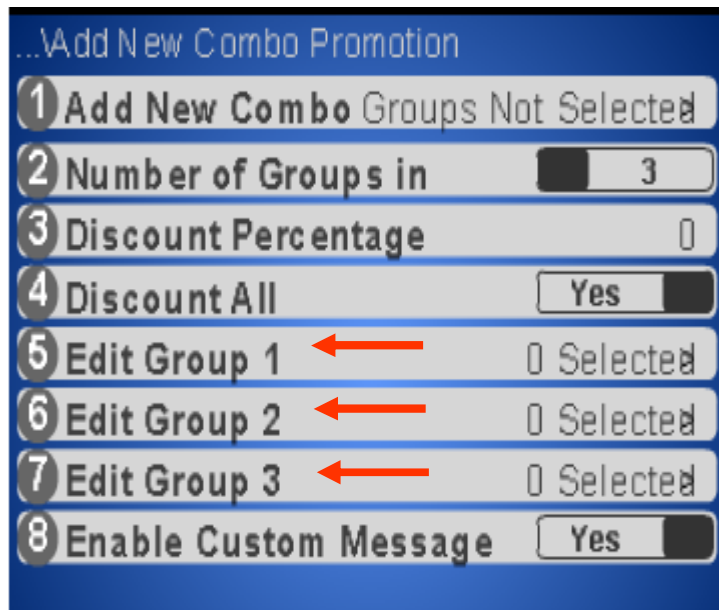



Special Vend Modes

Combo Vend – Add a New Combo Vend

Press 1 to add all selections on the tray to the group.

Press 2 to remove all selections on the tray from the group.

Press the index number in front of any selection number to add or remove a checkmark from that selection. A checkmark means that selection will be active for the Combo Vend group.

In some cases the bottom half of the OK button will be lit, pressing when lit will allow you to scroll down to additional selections on the shelf that do not fit on the screen.

Press the X key to exit and choose another tray to add selections to if desired.

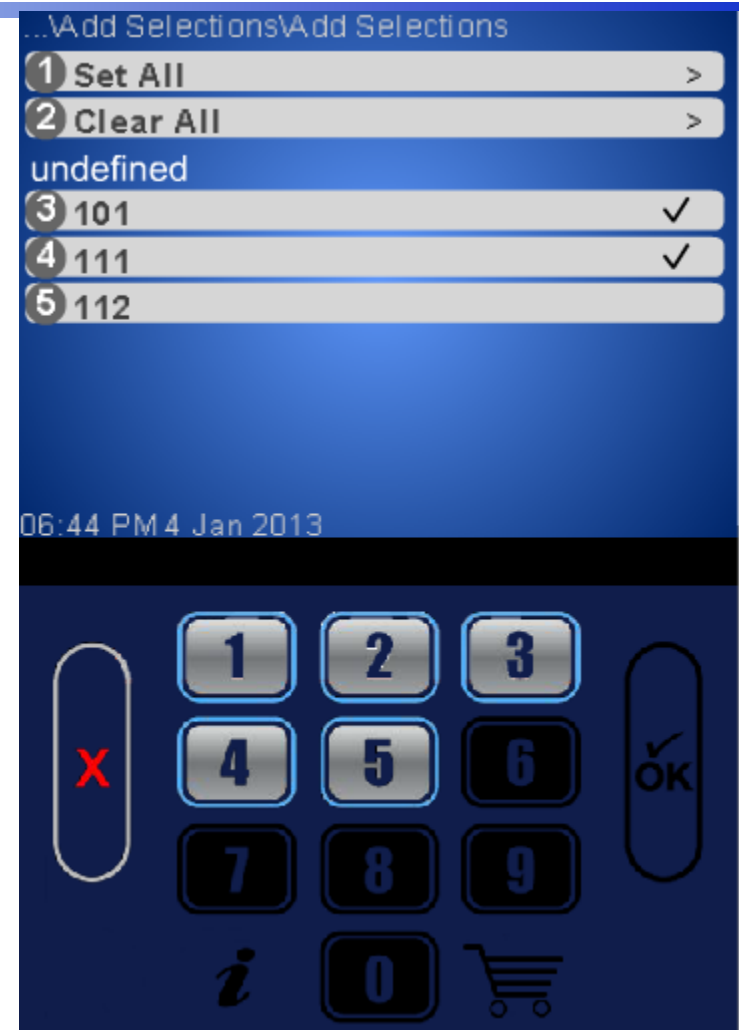



Special Vend Modes

Combo Vend – Add a New Combo Vend

After entering all selections for all groups
Press the X key to go back to the screen on
the right.

If you are setting a custom message for
Combo vends continue to the next screen.

**Important: If you are not setting a
custom message, be sure to save
your Combo Vend settings by
pressing 1. If you do not press 1
before exiting, your settings will not
be saved! You must have selections
added into all groups before you can
save by pressing 1.**

...Add New Combo Promotion

- 1 Add New Combo Groups Not Selected
- 2 Number of Groups in
- 3 Discount Percentage
- 4 Discount All
- 5 Edit Group 1
- 6 Edit Group 2
- 7 Enable Custom Message

07:02 PM 4 Jan 2013

X 1 2 3 4 5 6 7 8 9 0 i OK



Special Vend Modes

Combo Vend – Enable Custom Message

Press 7 to toggle Enable Custom Message to Yes to set a custom message. This message will be displayed when Combo Vend is active.

An additional menu item will appear, choose 8 to create the Custom Message

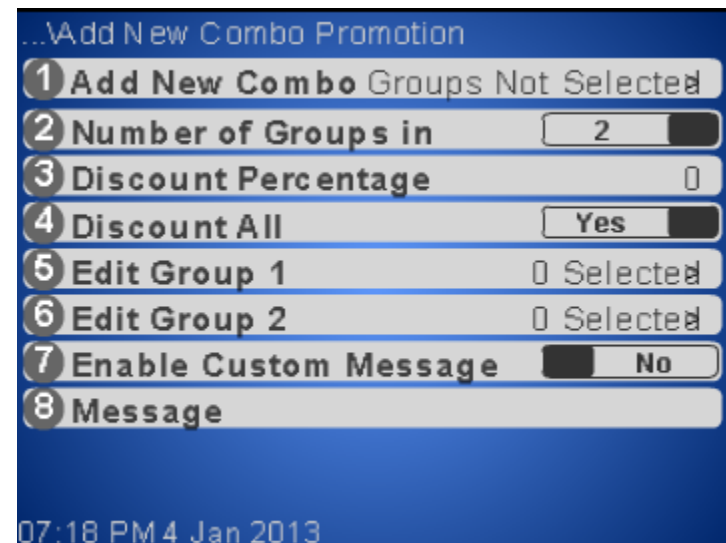
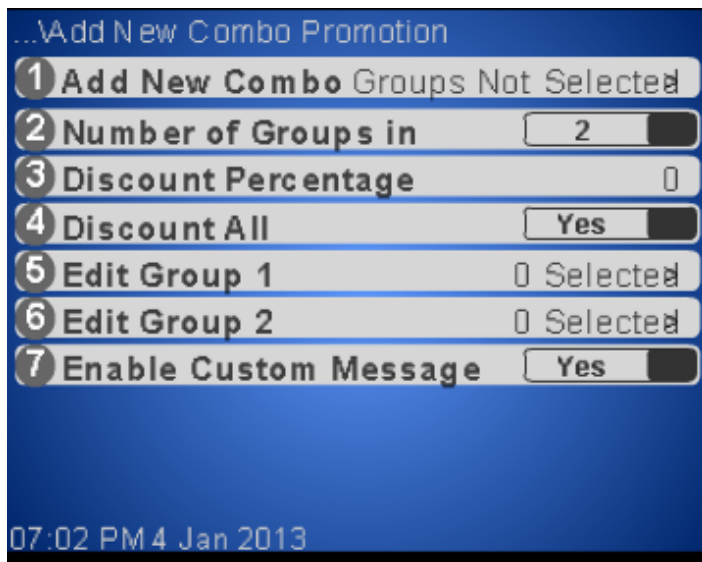



Special Vend Modes

Combo Vend – Enable Custom Message

- A numeric box will appear as a reference for the numbers to push on the keypad.
- As an example, if you want to enter the letter b you would press button 2 twice.
- Pressing **i** on the keypad will change the reference box between numbers letters and caps.
- The  is the backspace key.
- Once the message is entered press OK.

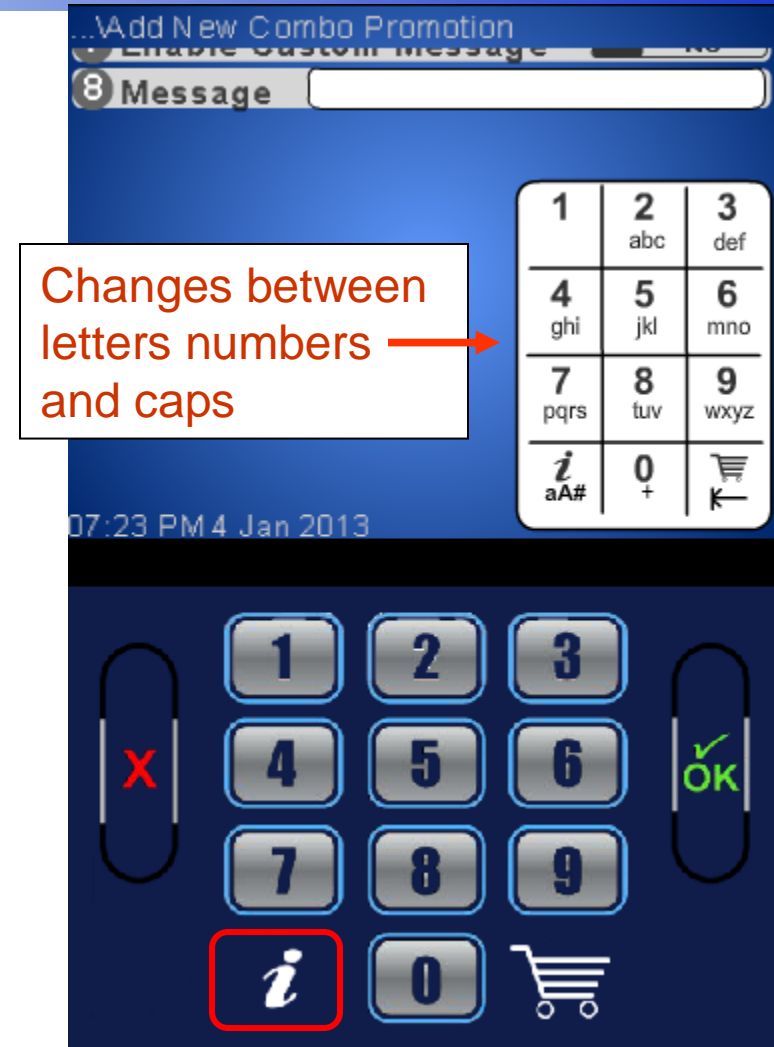

Continued →



Special Vend Modes

Combo Vend – Enable Custom Message

After entering your custom message, press the X key back to the screen on the right.

Important: Save your Combo Vend settings by pressing 1. If you do not press 1 before exiting, your settings will not be saved!

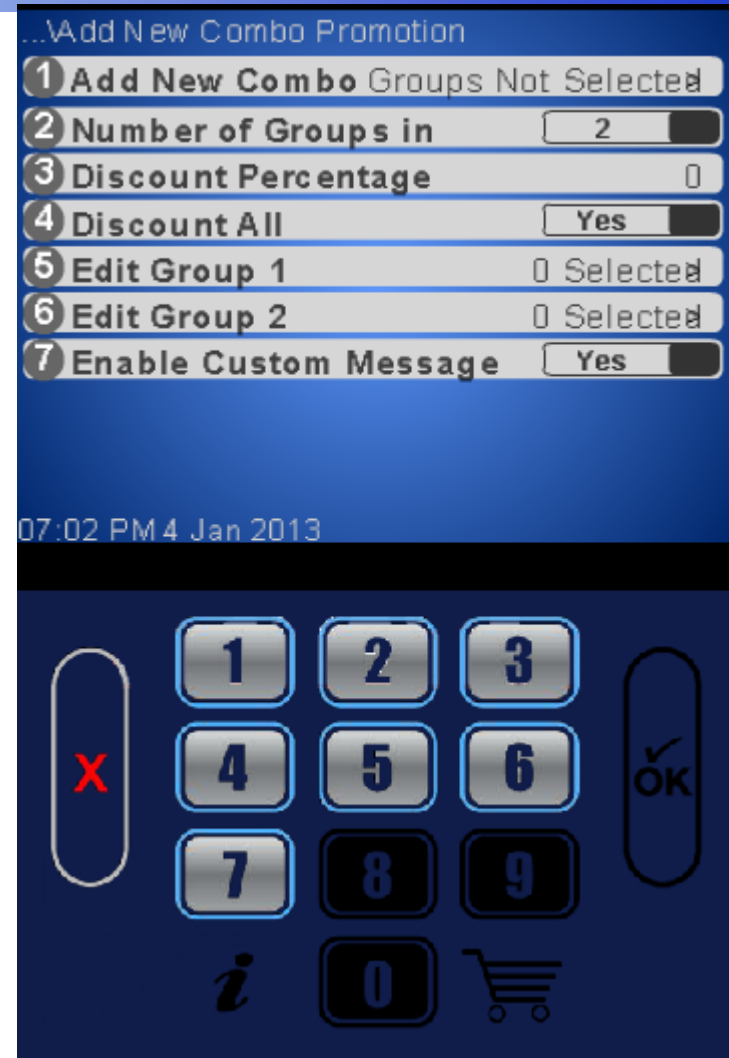



Special Vend Modes

Combo Vend – Delete Promotion

Select 3 on the Keypad to Delete an existing promotion

Select the promotion to Delete and press OK

Press 1 to confirm or 2 to back out

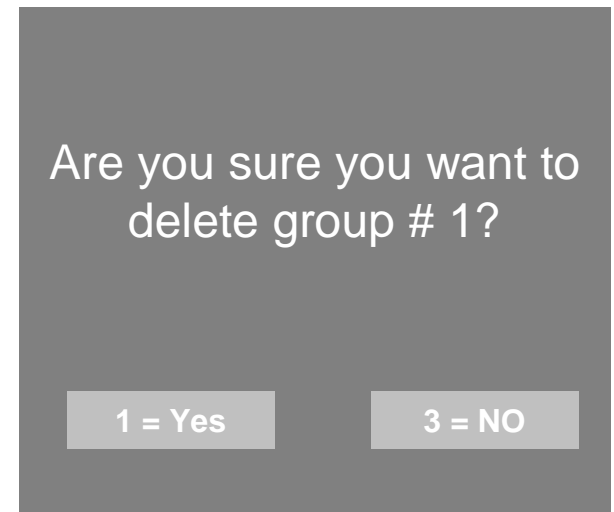
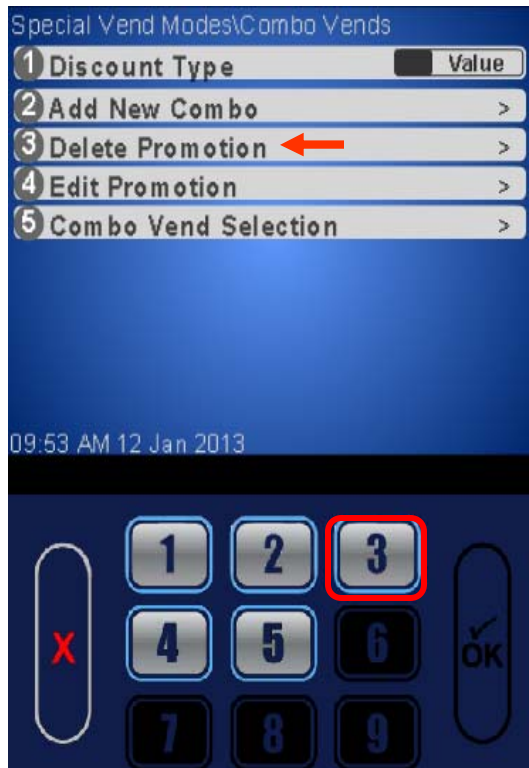

6
Special Vend
Modes

Special Vend Modes

Combo Vend – Edit Promotion

Select 3 on the Keypad to Edit a Group



Select the promotion you want to Edit.



Use the keypad to Select the item you wish to Edit.
Save the changes when you are done Editing by pressing 1.





Special Vend Modes

Combo Vend – View Assigned Selections

Select 5 on the Keypad to view selections currently assigned to a combo Vend

Select the tray you wish to View

The display shows each selection on the tray and the promo # it is assigned to.

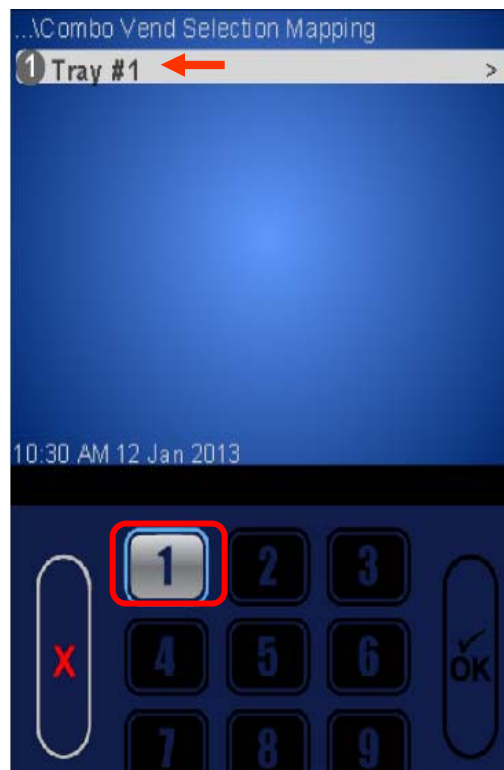



Special Vend Modes

Token Enable

Token Enable

- This Menu allows you to choose the selections the customer is permitted to purchase with Tokens or Coupons.
- **Note:** Tokens must be enabled in the Monetary menu under Bill Acceptance for Tokens or Coupons to work.
- Your Coin Mechanism or Bill Acceptor must be tuned and/or configured to accept your Token or Coupon.



Continued 



Special Vend Modes

Token Enable

Select 4 on the Keypad to assign to selections to work with Tokens/Coupons

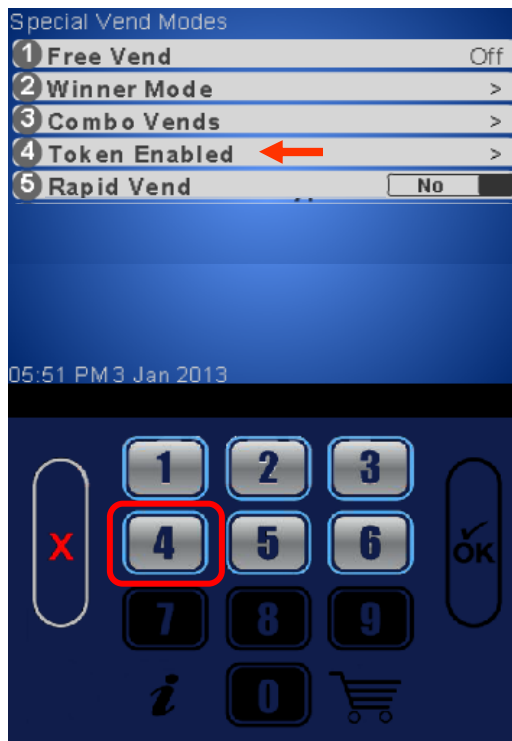

Select the tray you wish to assign selections to work with Tokens/Coupons



Use the keypad to select all, clear all or add a checkmark to the selections to work with a Token/Coupon

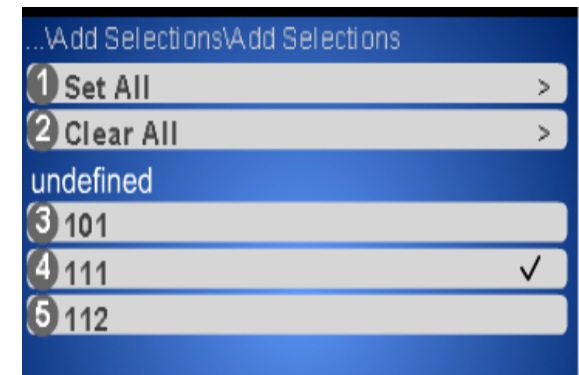



Special Vend Modes

Rapid Vend

Rapid Vend Mode

- Rapid Vend Mode when set to yes causes the machine to be set up as single vend only merchandiser.
- The product will vend of a product as soon as a selection is made without pressing OK.
- Press 5 to toggle Rapid Vend between Yes and No

Note: The shopping cart is automatically disabled when Rapid Vend is turned on.

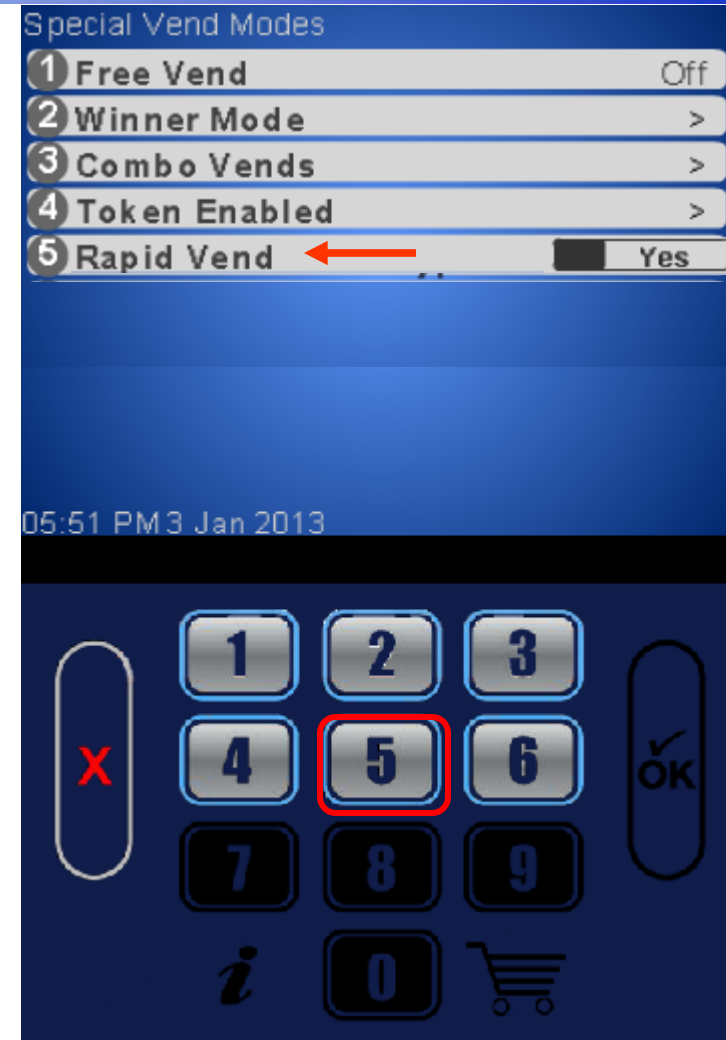

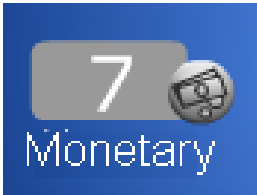

Monetary Menu

Monetary Menu Icon

- Allows the programming of settings for all credit devices and related functions.
- Press number 7 on the keypad to enter the Monetary Menu.

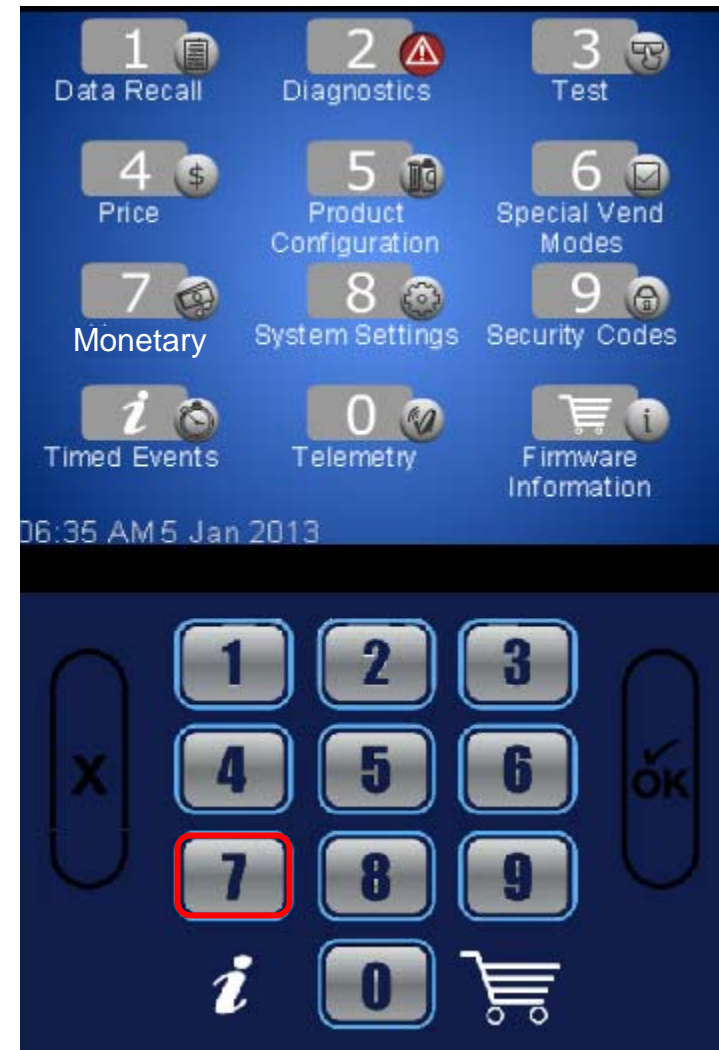



Money Menu Coins In/Out

Press number 1 to enter Coins In/Out menu.

The display will show the coin tube values and coin counts. This menu can also be used to dispense coins from coin mechanism by pressing the number on the keypad next to the value of the coin.

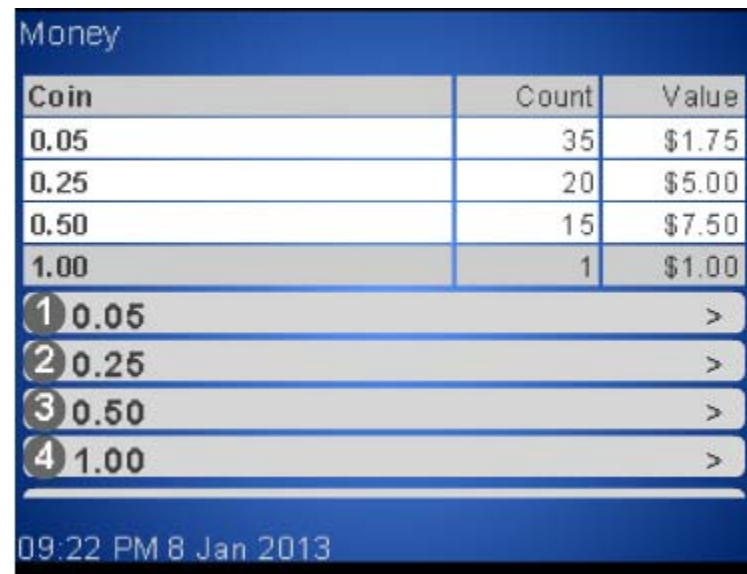
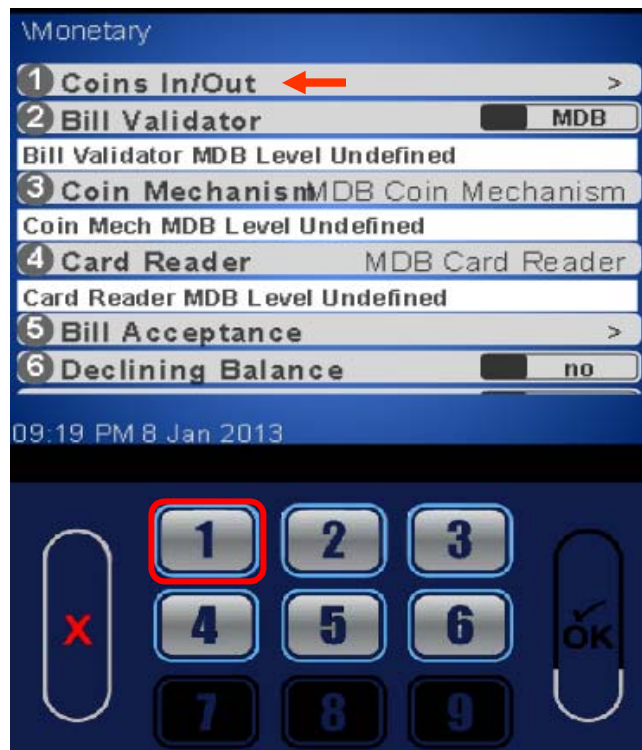

7 Monetary

Monetary Menu Coins In/Out

Press the bottom of the OK button to Set or View coin channels in the coin mechanism.

To set up the channels in your coin mechanism press 2. **This setting is not typically changed from the default of auto detect.**

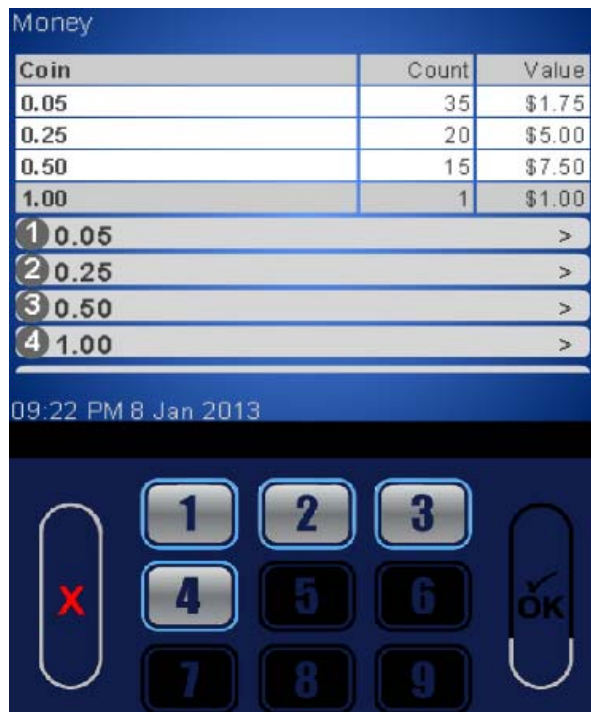

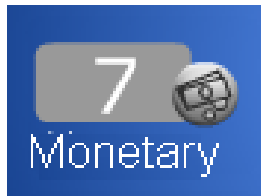

Monetary Menu

Coins In/Out

Press 1 to turn off Auto Detection for the coin tubes (**not recommended**). This will enable the menu that allow you to turn the coin mechanism channels on and off independently

Use the keypad to add or remove checkmarks from the channels. Removing a checkmark from a channel will disable the coin tuned to that channel.

Press the bottom of the OK button to scroll to the remaining of the 16 channels.



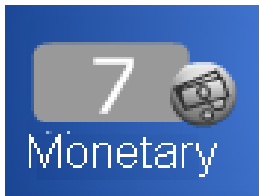

Monetary Menu

Bill Validator Enable

Press number 2 on the keypad to toggle between **MDB** or **No Bill** validator.

Once communication is established the communication level of the Bill Validator will be shown

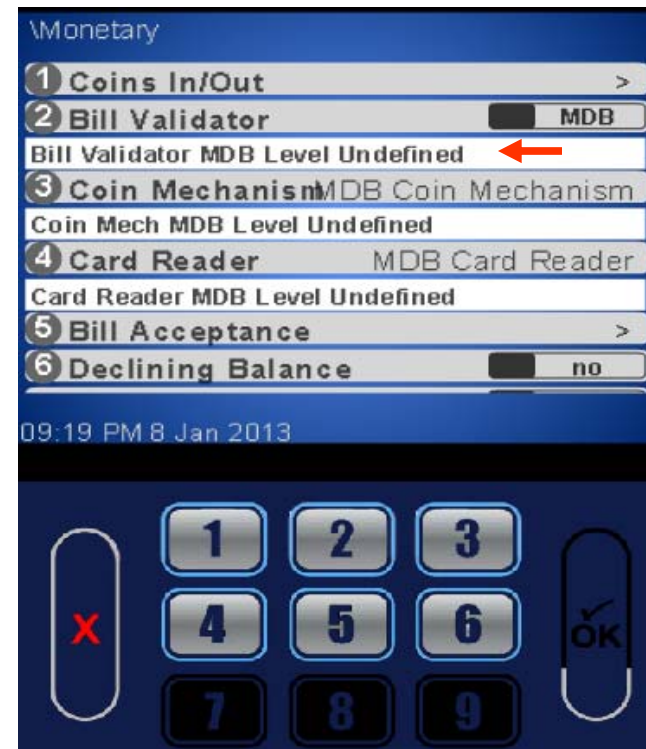
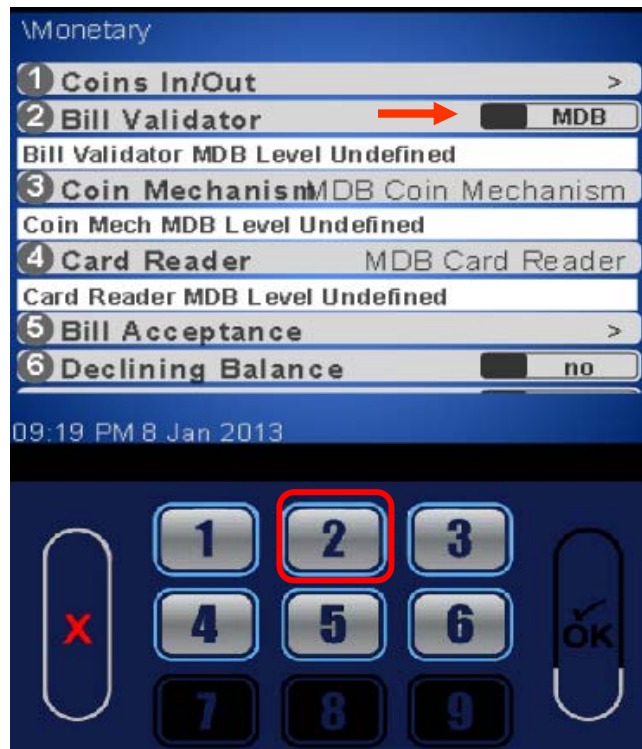

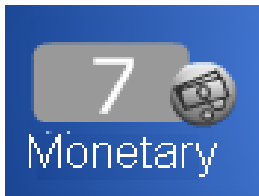

Monetary Menu

Coin Mechanism Enable

Press number 3 on the keypad to choose the coin mechanism type. The current setting is shown without entering the menu.

Choose your Coin Mechanism option and press OK.
Note: Exec is not used in the US.



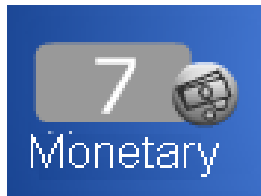

Monetary Menu

Card Reader

Press number 4 on the keypad to choose your card reader option. The current setting is shown without entering the menu.

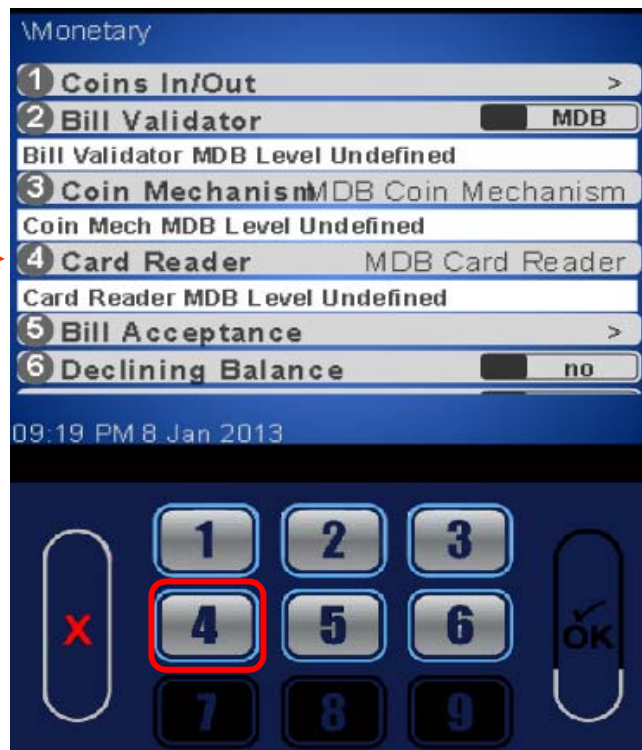

Choose your Card Reader option and press OK. Onboard is a swipe built into the front of the machine all other will be MDB Card Reader.

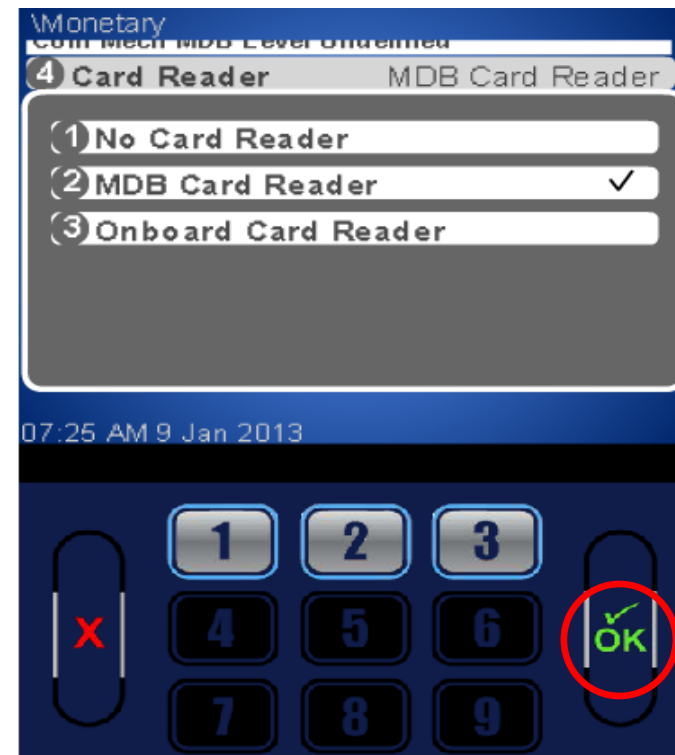

7 Monetary

Monetary Menu Bill Acceptance

Press 5 on the keypad to enter into the Bill Acceptance menu. All denominations enabled by the Bill Validator will be shown

Press the corresponding number on the keypad to select or unselect the bill denominations you wish to accept/not accept. Token must be enabled to accept Tokens or Coupons. You will also need to choose what selections work with tokens or coupons in the Special Vend Modes Menu.

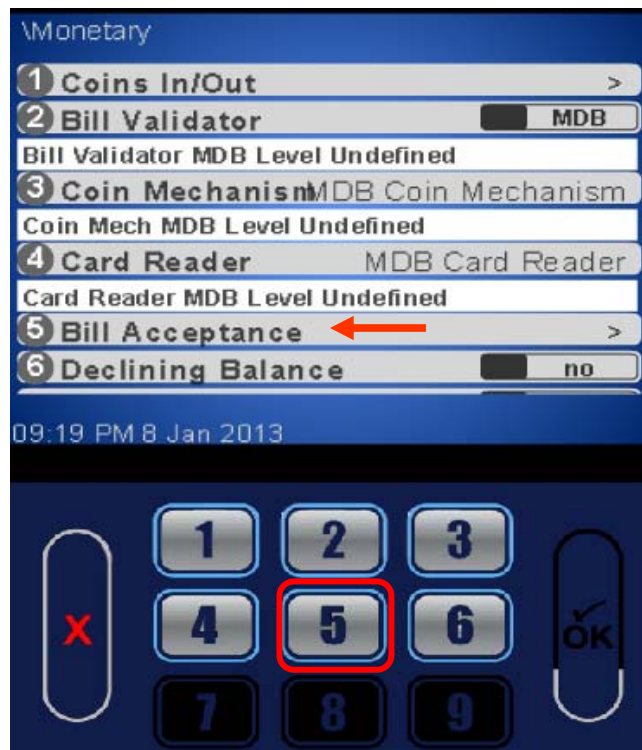

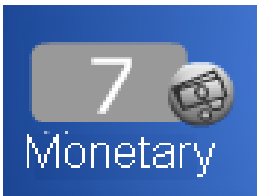

Monetary Menu

Declining Balance

Declining Balance

If Declining Balance is set to Yes the change due back after a vend will remain on the display allowing the customer to add more money to make an additional purchase.

– *Note: If set to yes, customer may press the coin return or X button to return remaining credit.*

- Press number 6 button on the keypad to toggle between Yes and No.
- Press the **X** button to exit this menu mode.

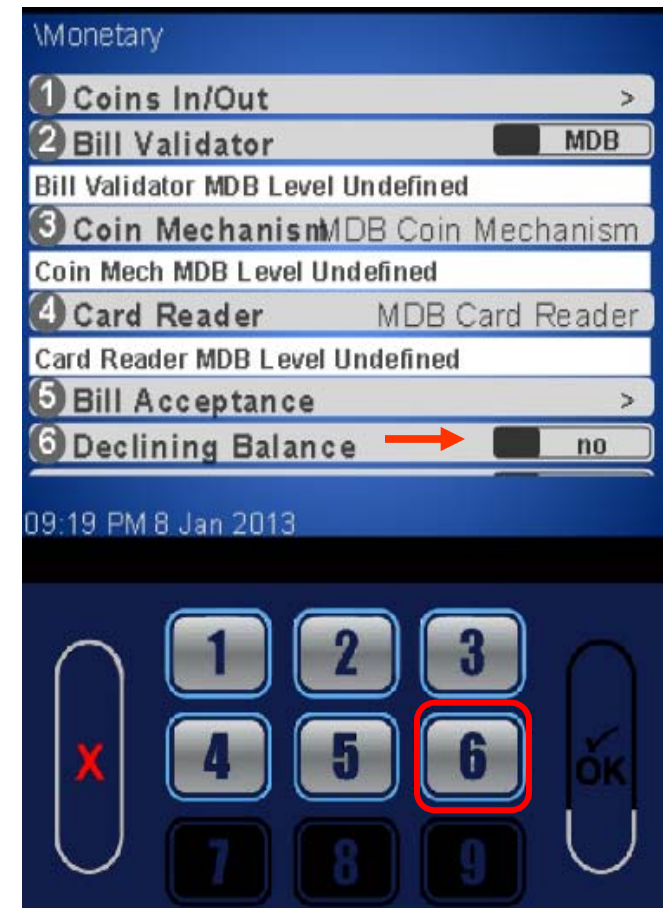

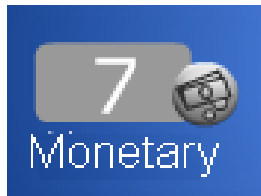

Monetary Menu

Force Vend

Force Vend

When Force Vend is set to **No**:

- All money inserted can be paid back by pressing the X to cancel the transaction.

When Force Vend is set to **Yes**, a consumer will not be able to receive their credit back when:

- The established credit meets or exceeds the minimum price of the selections in the machine
- Any bills are stacked in establishing credit
- Any non-tube coins are inserted in establishing credit
- A “No Change Without Purchase” message will be displayed when a consumer attempts to return credit.

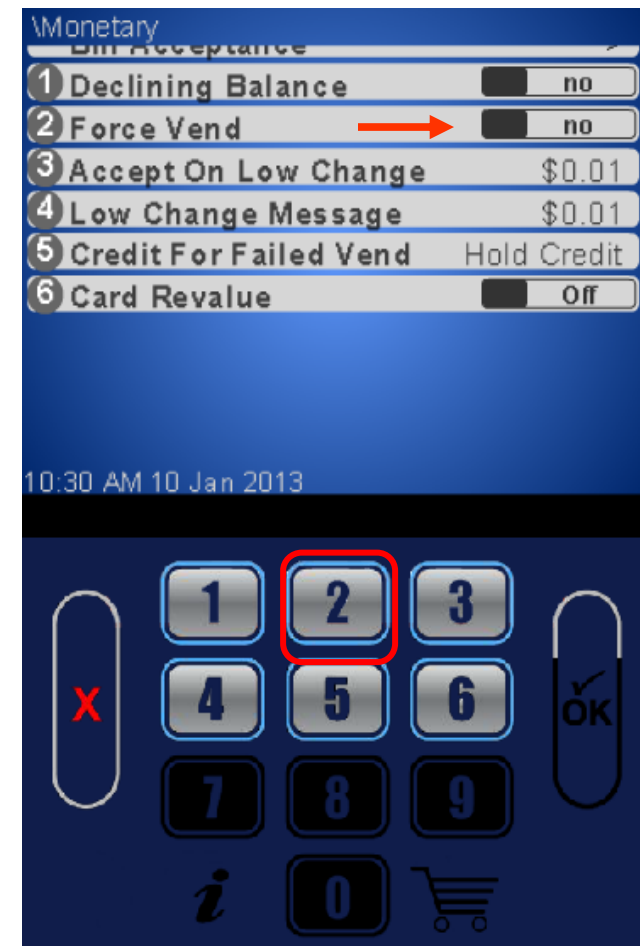



Monetary Menu

Force Vend

Press the highlighted lower half of the OK button to scroll down to Force Vend

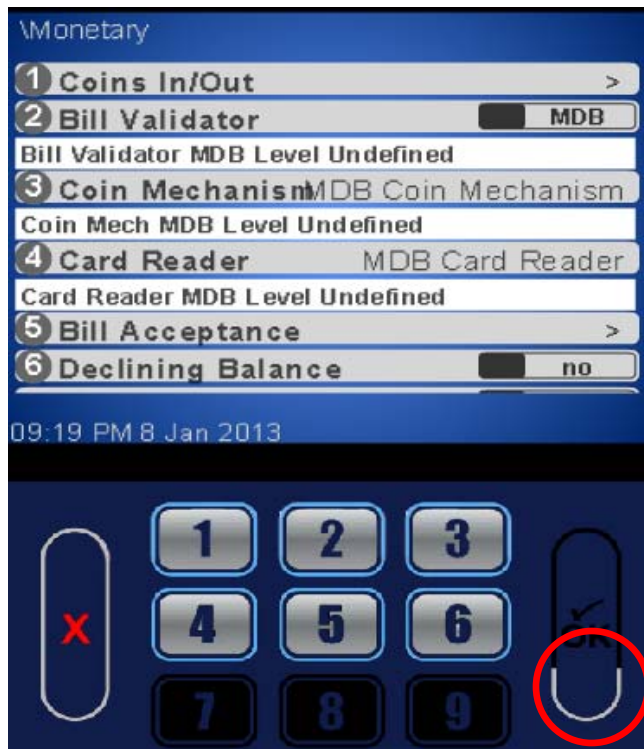

Press 2 to toggle Force Vend between Yes & No



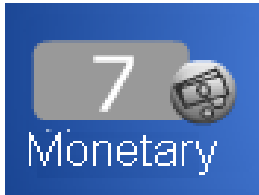

Monetary Menu

Accept on Low Change

Accept On Low Change

- Used to set acceptance of a bill depending on how much change is registered in the coin mechanism.
 - If set to default \$0.00, the machine will only accept a bill when the coin mech has enough change to pay back full credit.
 - If a value is set to anything other than \$0.00 bills will be accepted to the set value even though change may not be available (customer may get short changed).

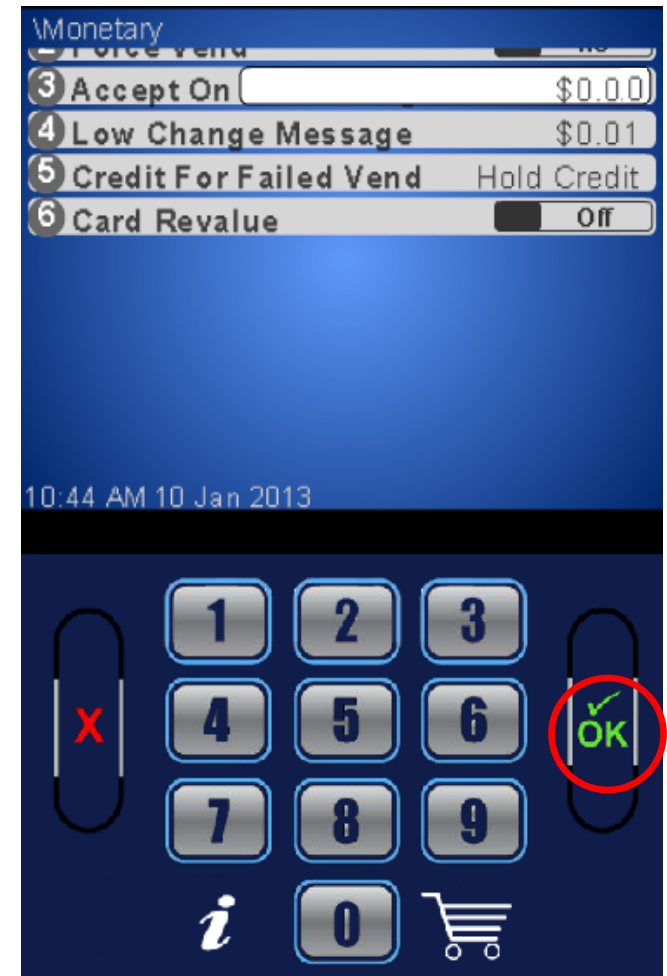

7 Monetary

Monetary Menu Accept on Low Change

Press the highlighted lower half of the OK button to scroll down to Accept on Low Change

Press 3 to enter the value of money you wish to accept when no change is available. Setting this to any other than \$0.00 may cause the customer to get short changed. Press OK to save

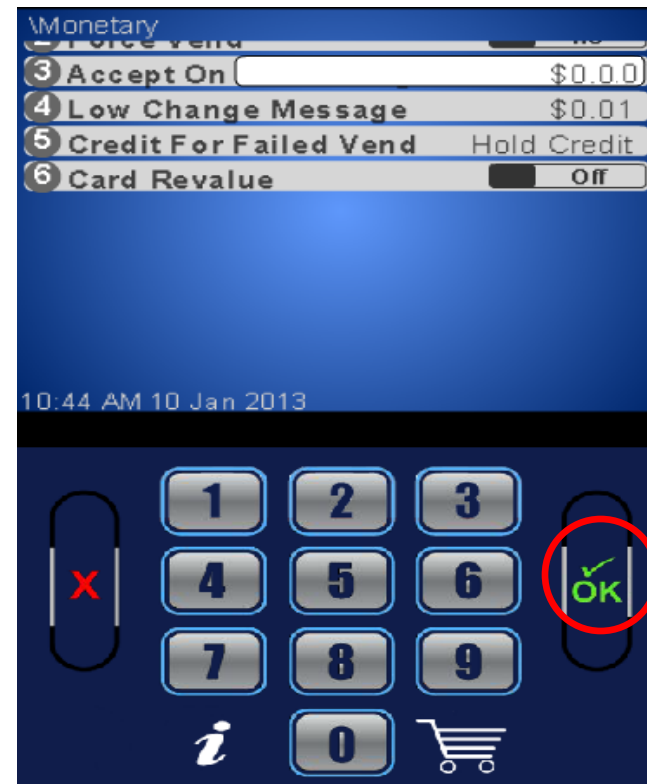
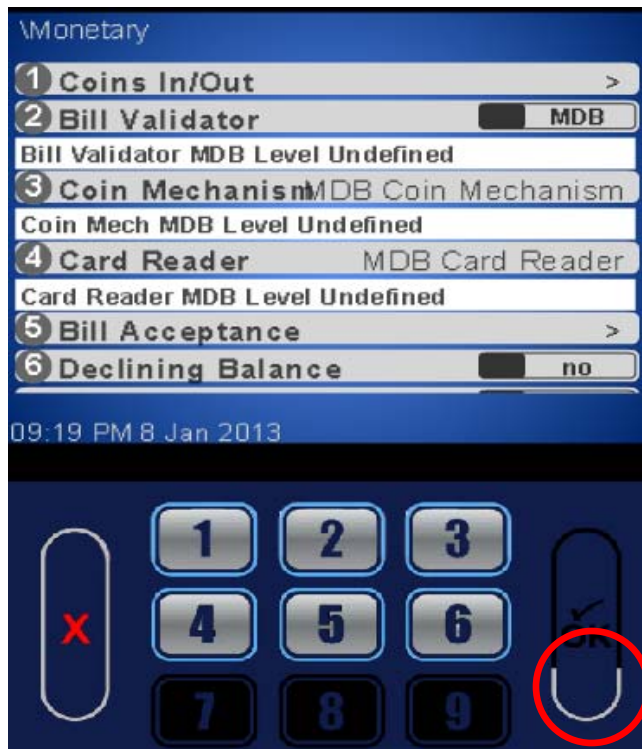

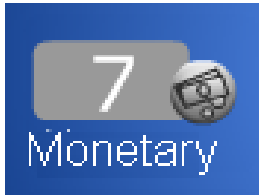

Monetary Menu Low Change Message

Low Change Message

- Used to set the lowest amount registered in the coin mechanism before the display shows “USE EXACT CHANGE”
- Press the number 4 button on keypad then enter lowest value on corresponding line above (default setting of \$1.00 recommended)
- Press the **OK** button when lit to lock in setting.
- Press the **X** button to exit this menu mode.

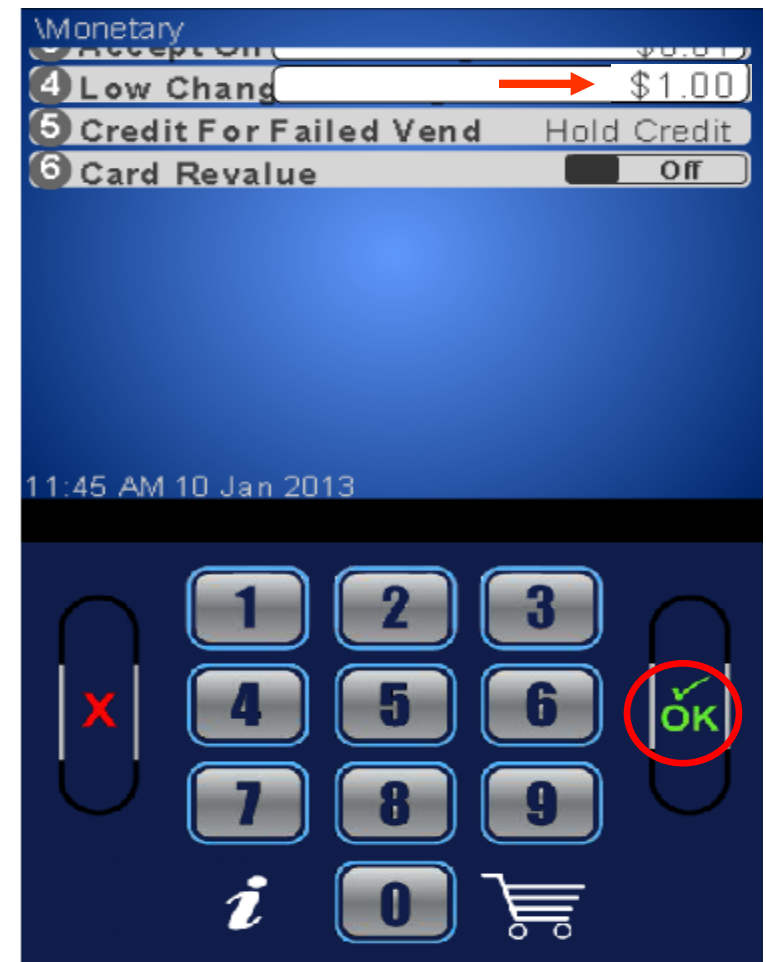

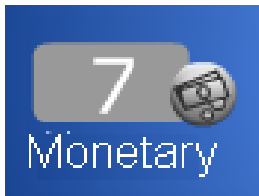

Monetary Menu

Low Change Message

Press the highlighted lower half of the OK button to scroll down.

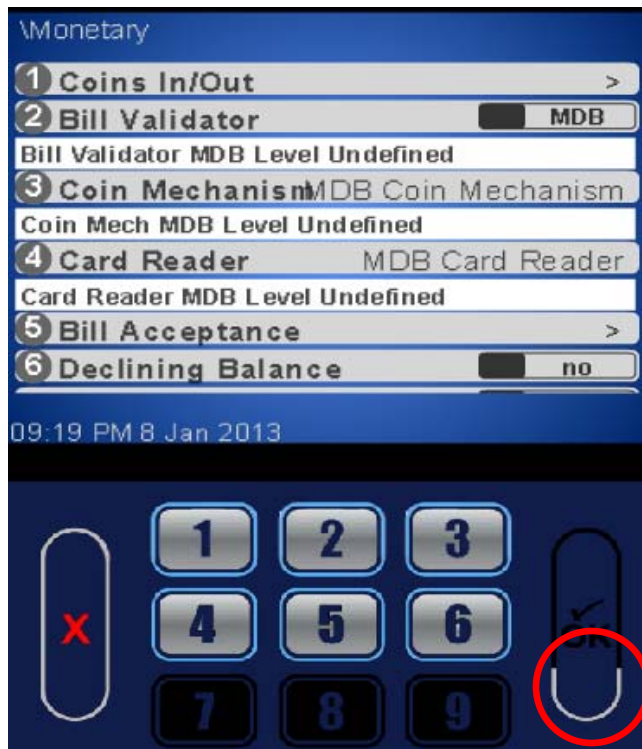

Press the number 4 button on keypad then enter lowest value on corresponding line above (default setting of \$1.00 recommended)

Press OK to save



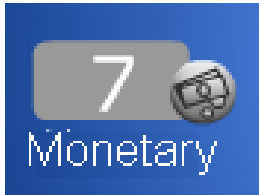

Monetary Menu

Credit for Failed Vend

Credit For Failed Vend

- Press the down button to view lower screen
- Used to determine credit for a failed vend
- Press the number 3 button on the keypad to change between the two settings:
 - **Return** = In the event of a failed vend, the credit will be returned automatically.
 - **Hold** = In the event of a failed vend the credit will remain on the machine
- Press OK to save
- Press the **X** button to exit this menu mode.

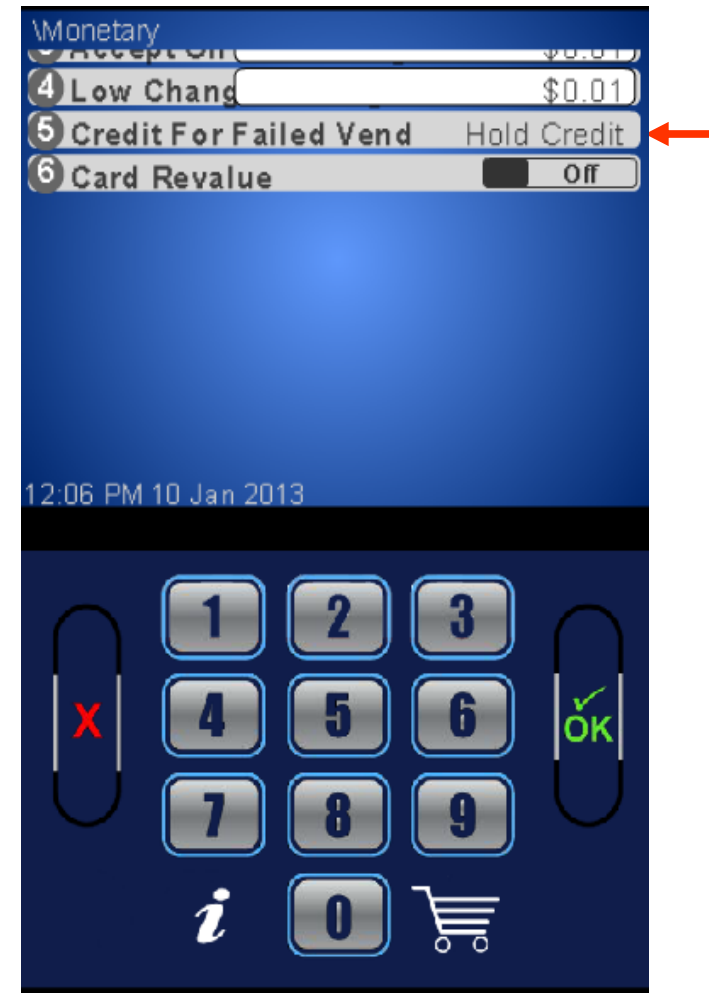

Continued →

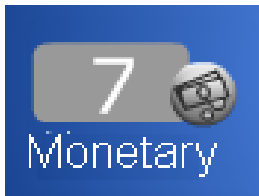

Monetary Menu

Credit for Failed Vend

Press the highlighted lower half of the OK button to scroll down.



Press the number 5 on the keypad to advance to the next screen

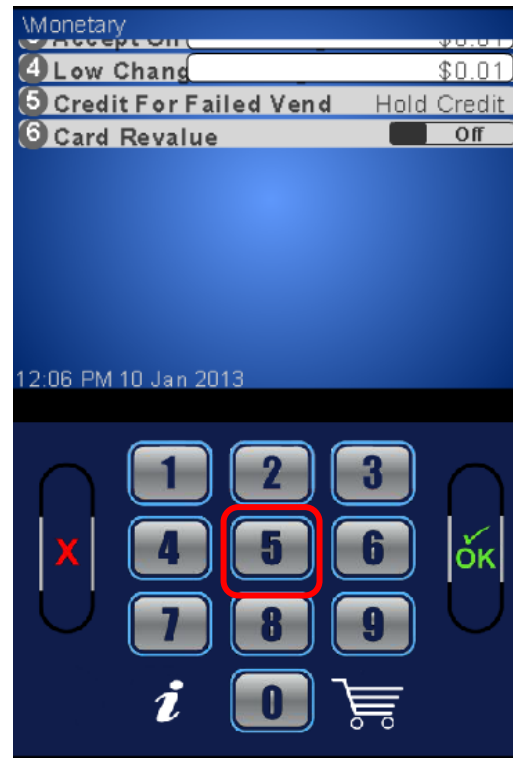

Choose 1 or 2 to Return Change or Hold Credit after a failed vend. Press OK to save.

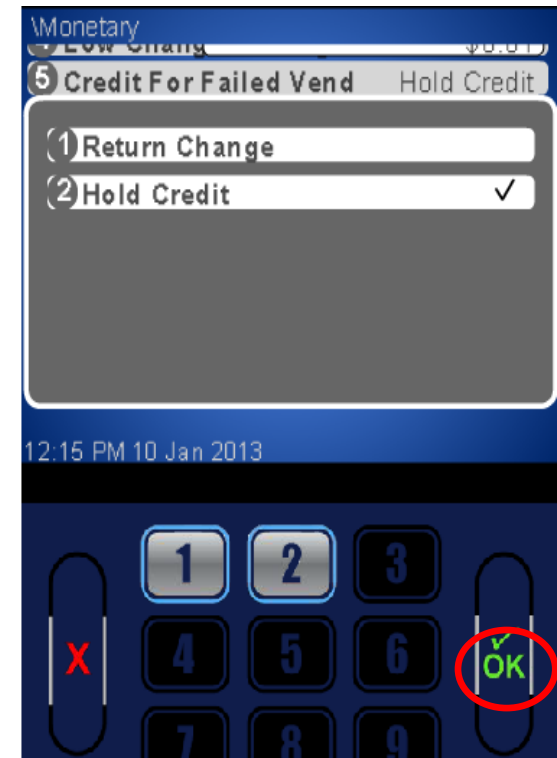

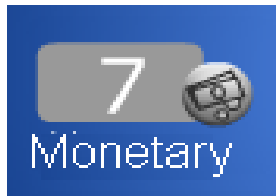

Monetary Menu

Card Revalue

Card Revalue

- Used when the machine is equipped with a card reader or other monetary device that is capable of having value added.
- Press the number 6 on keypad to toggle the setting between Off and On.
 - **Off** = Credit cannot be transferred.
 - **On** = Allows credit be transferred.
- Press the **X** button to exit this menu mode.

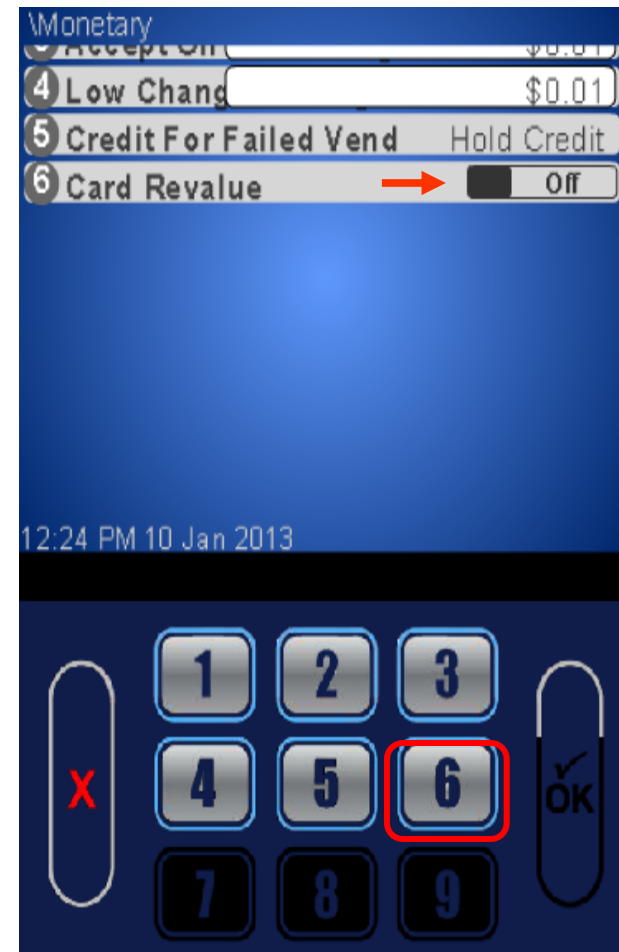

Continued



Monetary Menu

Card Revalue

Press the highlighted lower half of the OK button to scroll down.

Press 6 to toggle Card Revalue between Off and On.

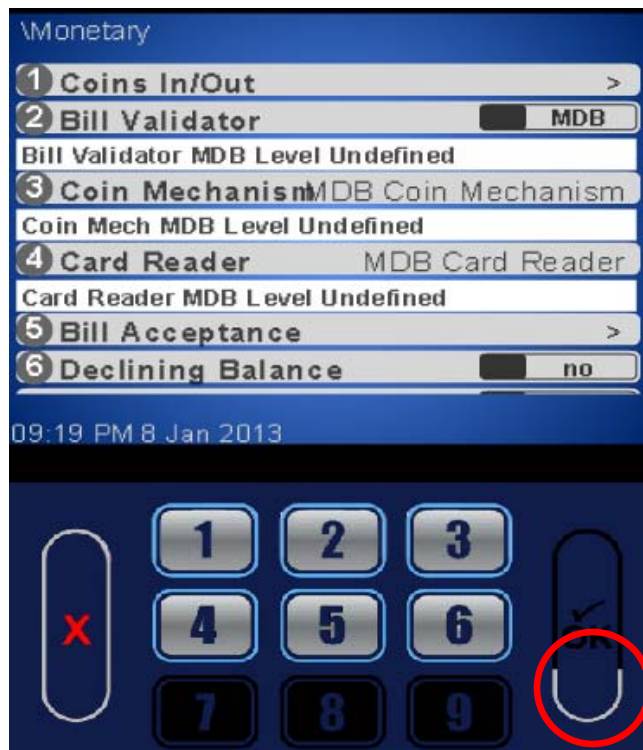



System Settings

System Setting Menu - Pressing 8 from the main menu will take you to the System Settings Menu.

Press the bottom of the OK button to scroll to the next menu

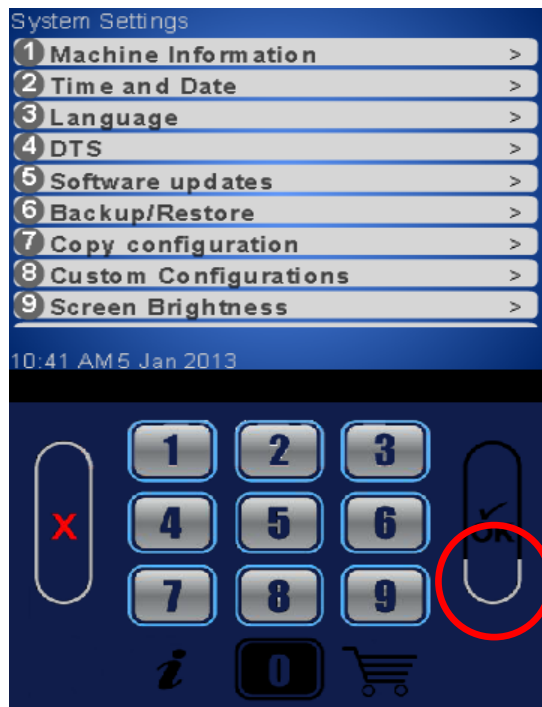

Press the top of the OK button to return to the previous menu

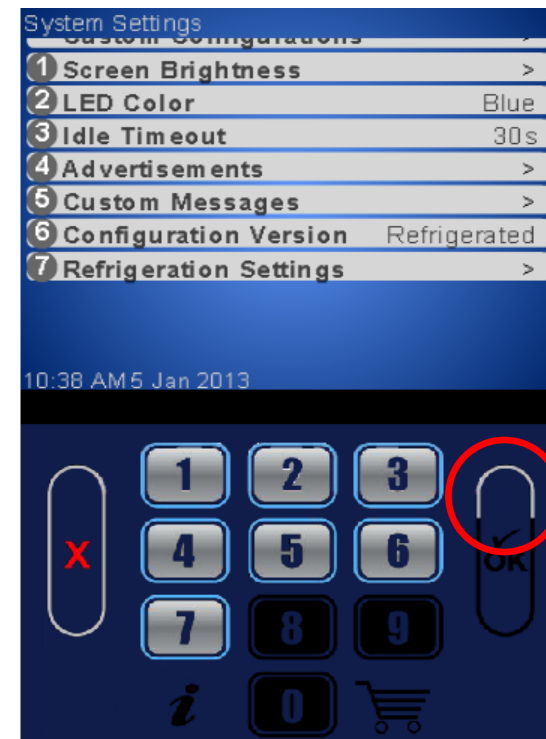



System Settings

Configuration Version (Machine Type)

Pressing 1 from the System Settings menu will take you to the Machine Information Menu.

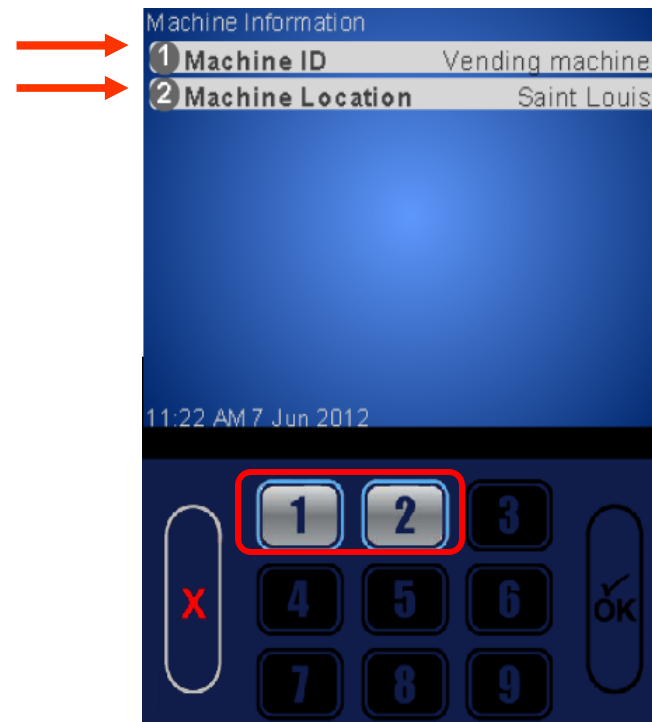
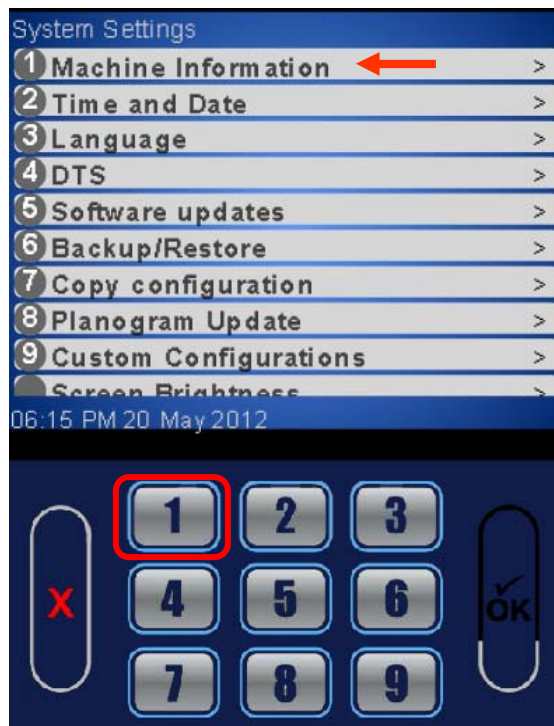

Press 1 or 2 to assign or change the Machine ID or Location ID. This ID can be text, numeric or a combination both.





System Settings

Configuration Version (Machine Type)

- A numeric box will appear as a reference for the numbers to push on the keypad.
- As an example, if you want to enter the letter b you would press button 2 twice.
- Pressing  on the keypad will change the reference box between numbers letters and caps.
- The  is the backspace key.
- Once the message is entered press OK.

Machine Information

1 Machine ID Vending machine

2 Machine Location Saint Louis

Changes between letters, numbers and caps

| | | |
|-----------|----------|-----------|
| 1 | 2 abc | 3 def |
| 4 ghi | 5 jkl | 6 mno |
| 7 pqrs | 8 tuv | 9 wxyz |
| * aA# | 0 + | # ← |

11:39 AM 7 Jun 2012

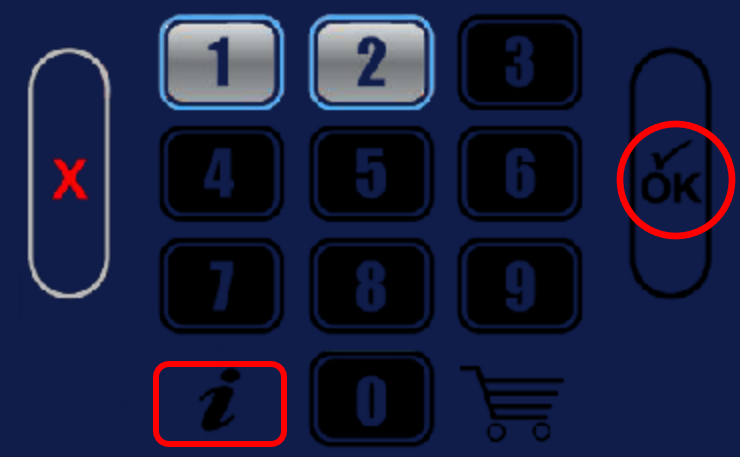



System Settings

Time and Date

Press 2 to access the Time and Date Menu.



Press 1 to set your Time Zone

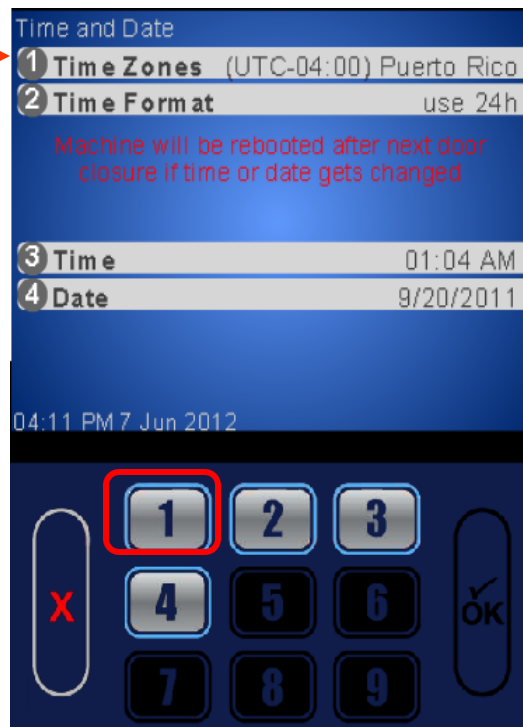

Press the number on the keypad for your Time Zone followed by OK

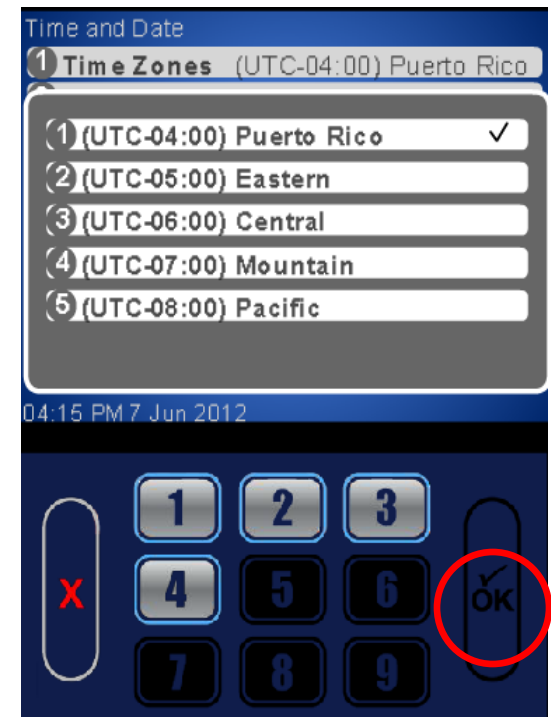



System Settings

Time and Date

Press 2 to change the Time Format between 24 hours and AM/PM.

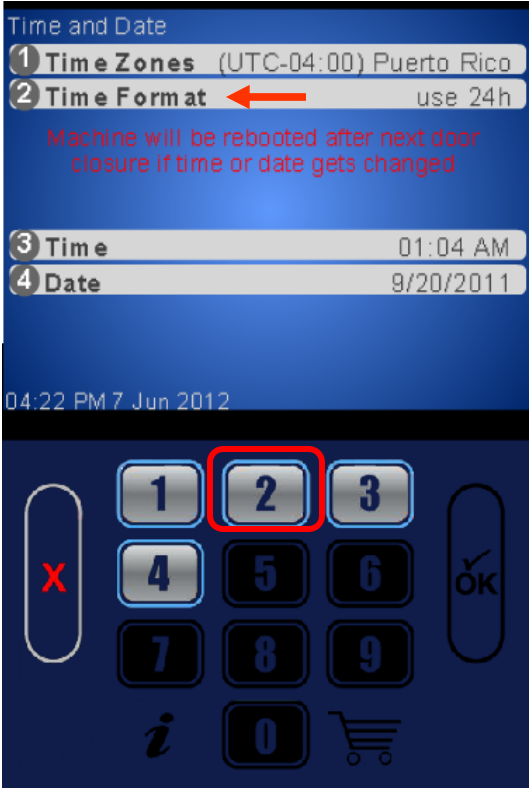

Press 1 or 2 to on the keypad to select your format. Press OK to save

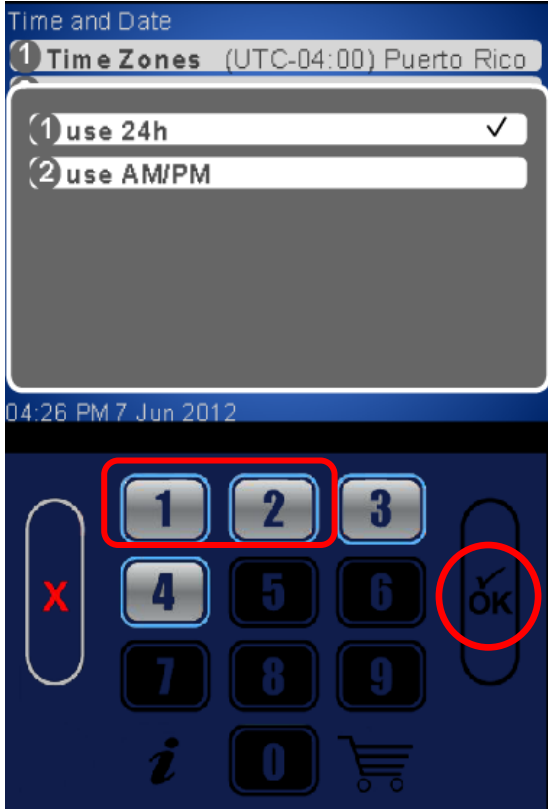



System Settings

Time and Date

Press 3 to change the current time .

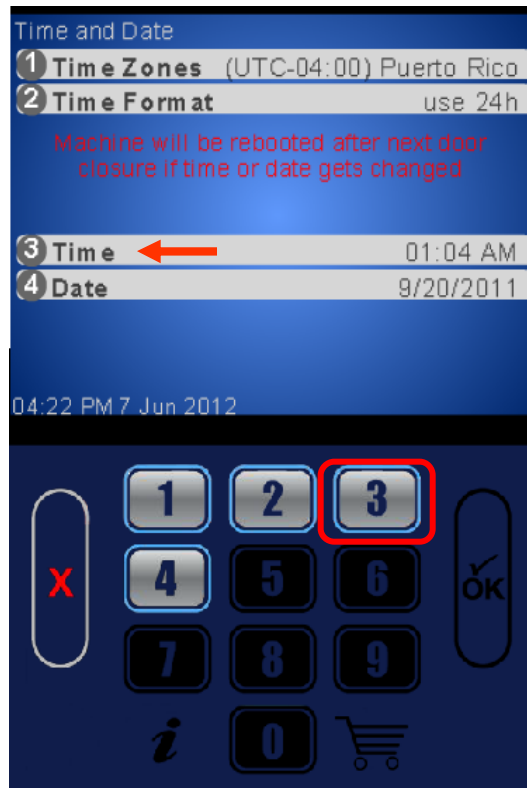

Enter the time using the keypad, use the / button to toggle between AM/PM.

Press OK when finished. Press the door switch after setting the time and/or date, this will cause a reboot and ensure the Time & Date are saved

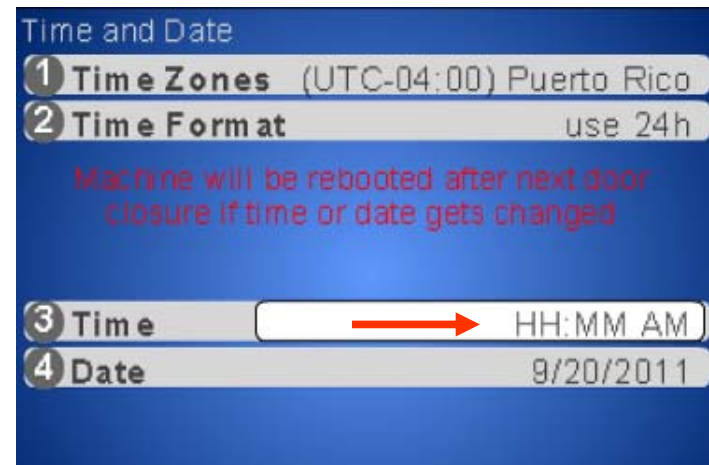



System Settings

Time and Date

Press 4 to change the Current Date .

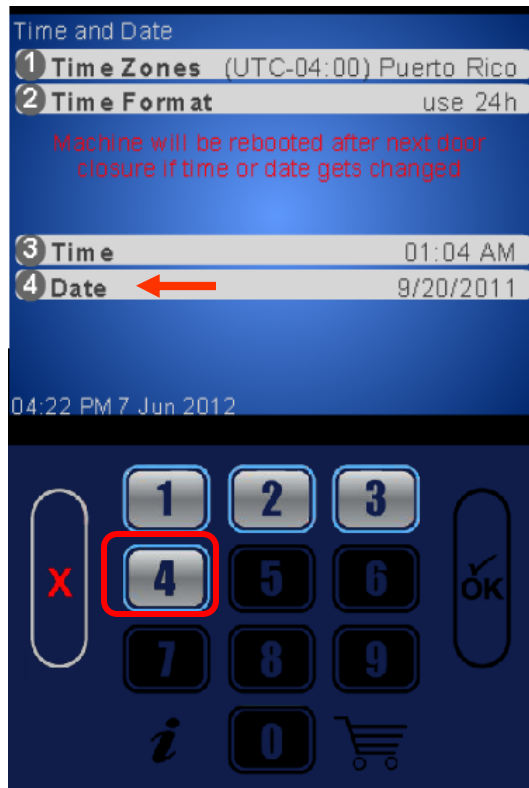

Use the keypad to enter the Date using the numeric format shown, **Press OK when finished. Press the door switch after setting the time and/or date this will cause a reboot and ensure the Time & Date are saved.**

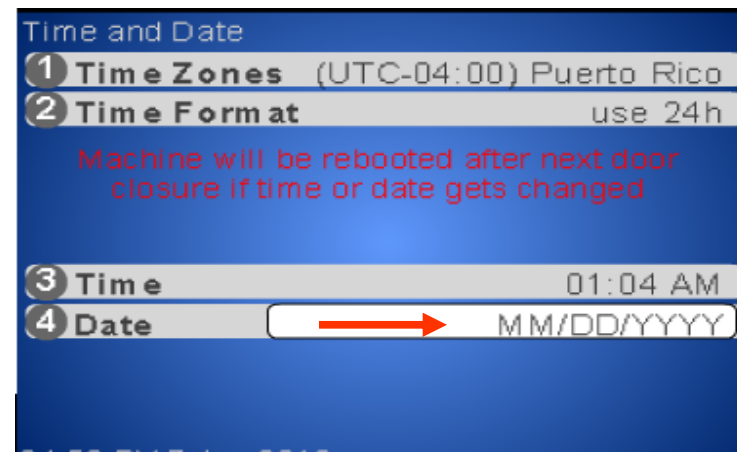



System Settings

Language

Press 3 to access the Language Menu.

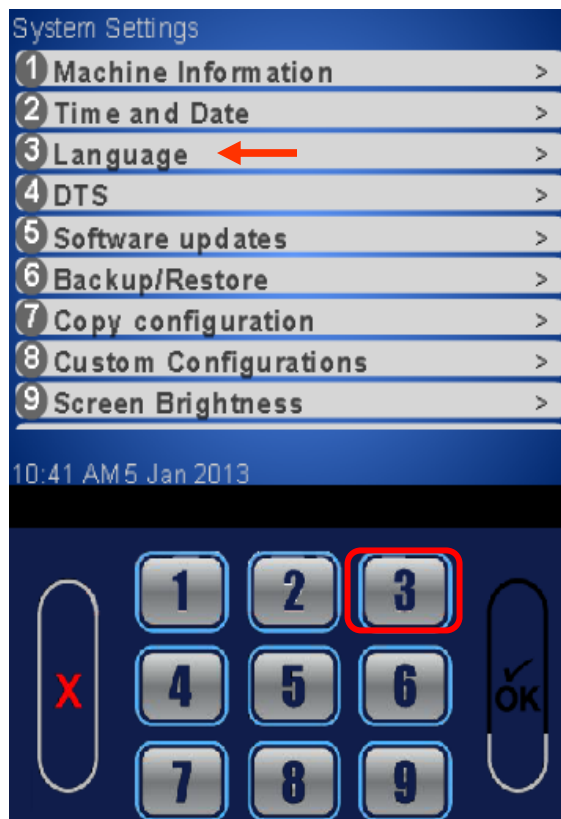

Press 1 to install a Language

Press 2 to remove a Language

Press 3 to apply a Language to Service Applications

Press 4 to apply a Language to the user interface

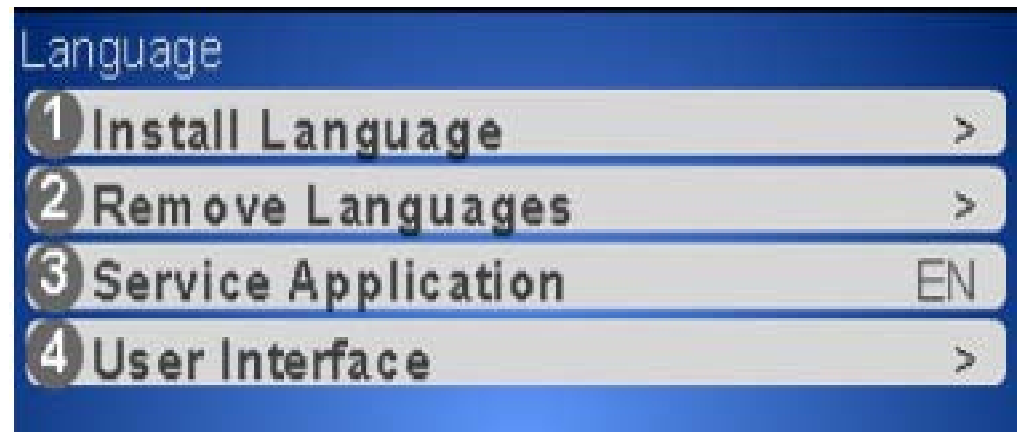



System Settings

Data Transfer Standard "DTS"

Press 1 to access the DTS Mode or Type.

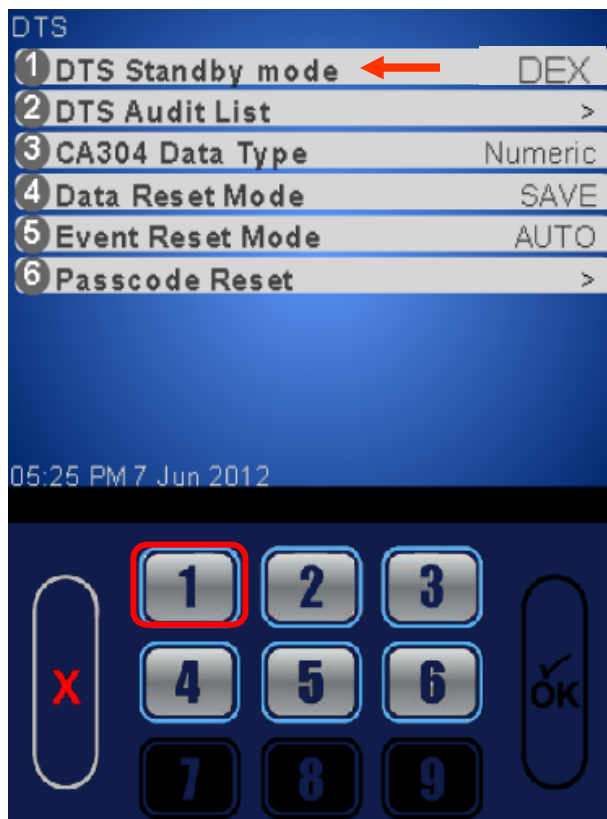

Press 1 or 2 on the Keypad followed by OK





System Settings

Data Transfer Standard "DTS"



Press 2 to access the DTS Mode or Type.

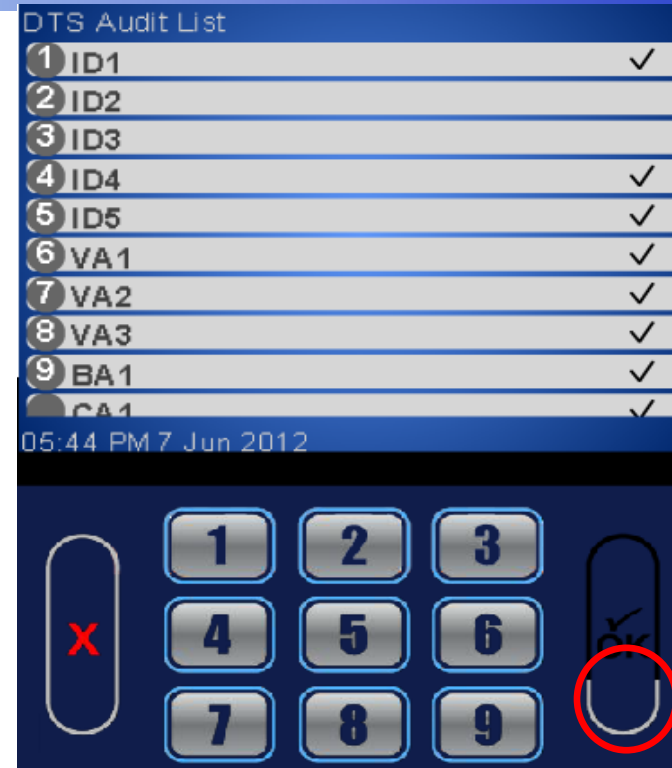

Use the keypad to add or remove items from the audit list. This menu gives you the ability to shorten the DEX file. Do not remove items without contacting your DEX provider or your Manufacturer Representative. Press the bottom of the OK button to scroll through the Audit List



System Settings

Data Transfer Standard "DTS"

Press 3 to access the CA304 Data Type Menu.

Press 1 for bills to be reported as currency (value of bills) or press 2 to report number of bills, press OK to save.





System Settings

Data Transfer Standard "DTS"

Press 4 to access the Data Reset Menu.

Press 1 for Auto, Press 2 for Save followed by OK





System Settings

Data Transfer Standard "DTS"

Press 5 to access the Event Reset Menu.

Press 1 for Auto, Press 2 for Save followed by OK

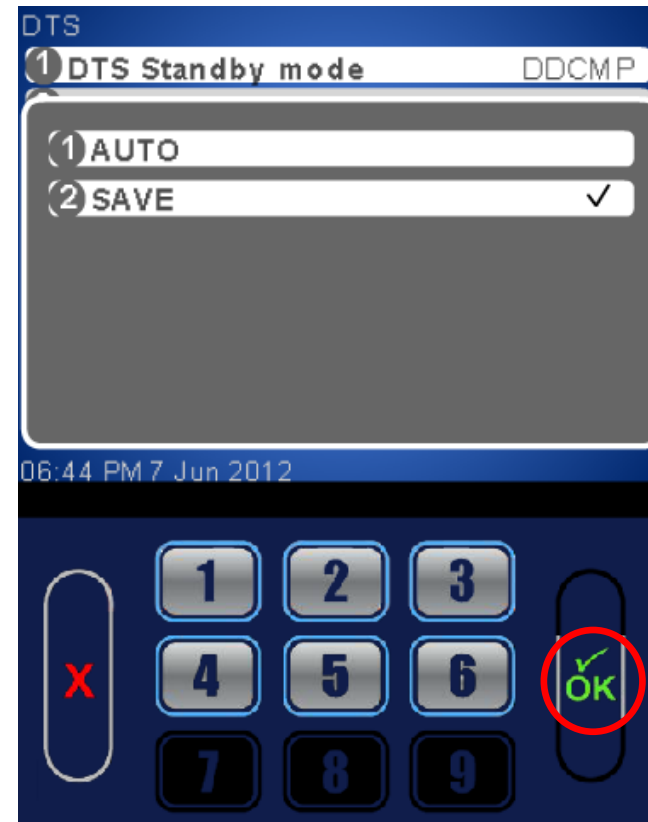



System Settings

Software Updates – Planogram

Loading a Planogram into the machine using a memory stick

- Before attempting to load a Planogram (POG) you must create a folder on your USB flash drive named atlas. Copy your POG file into the Atlas Folder.
- Plug a flash drive in to the control board on USB3 (The bottom one all by itself).
- You can have multiple Planograms in the atlas folder.
- Press Button 5 on the keypad to enter software update menu.

(Planogram Updates)

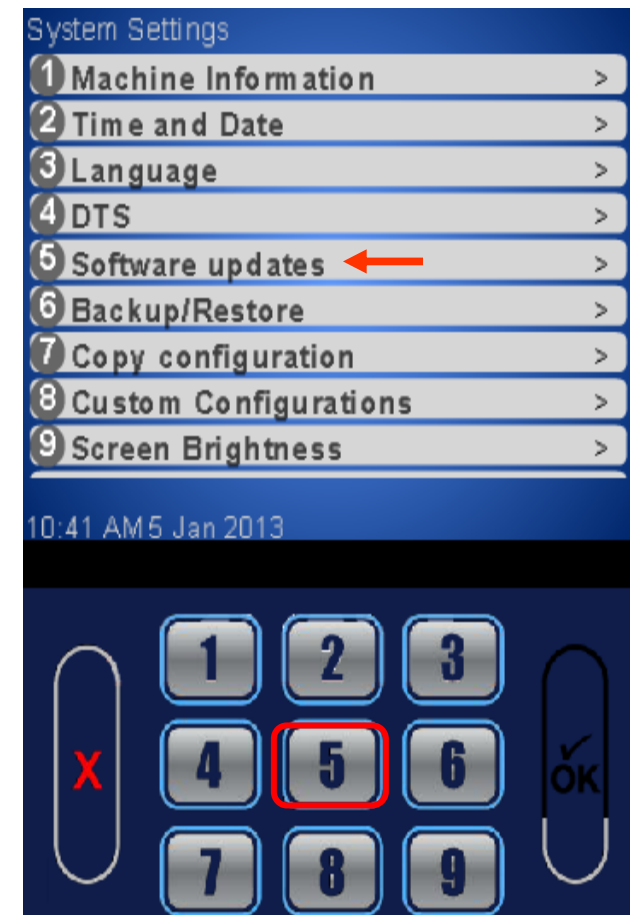



System Settings

Software Updates – Planogram

Press 5 to access
Software Updates
(Planogram Updates)

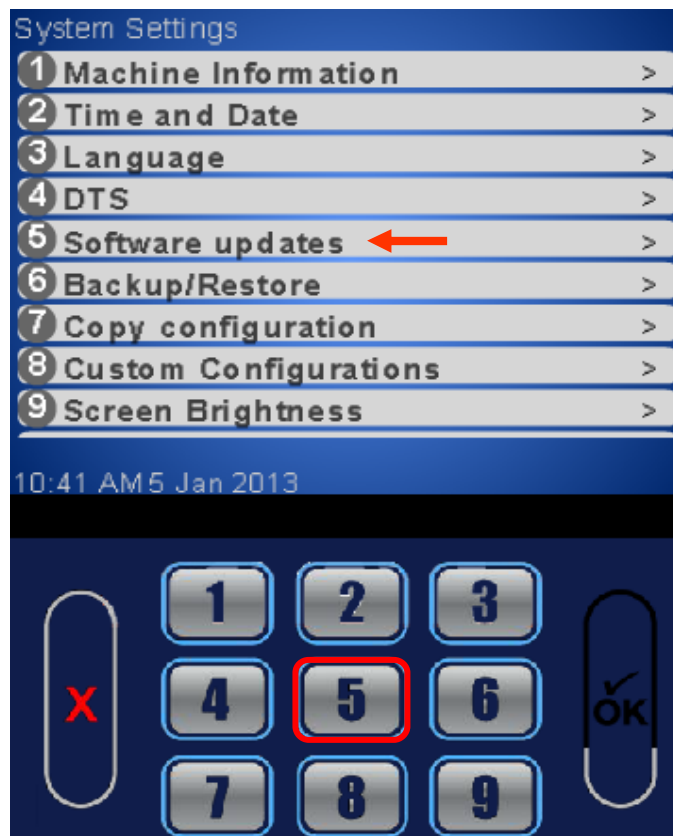

Choose the file you wish to
upload to the machine and
press 8 to start update.





System Settings

Software Updates – Planogram

- A conformation box will appear if you choose to update the POG
- The machine will re-boot if you choose Yes.
- The re-boot will take 5-7 minutes.
- It is a good idea to create a backup once the POG file is loaded.

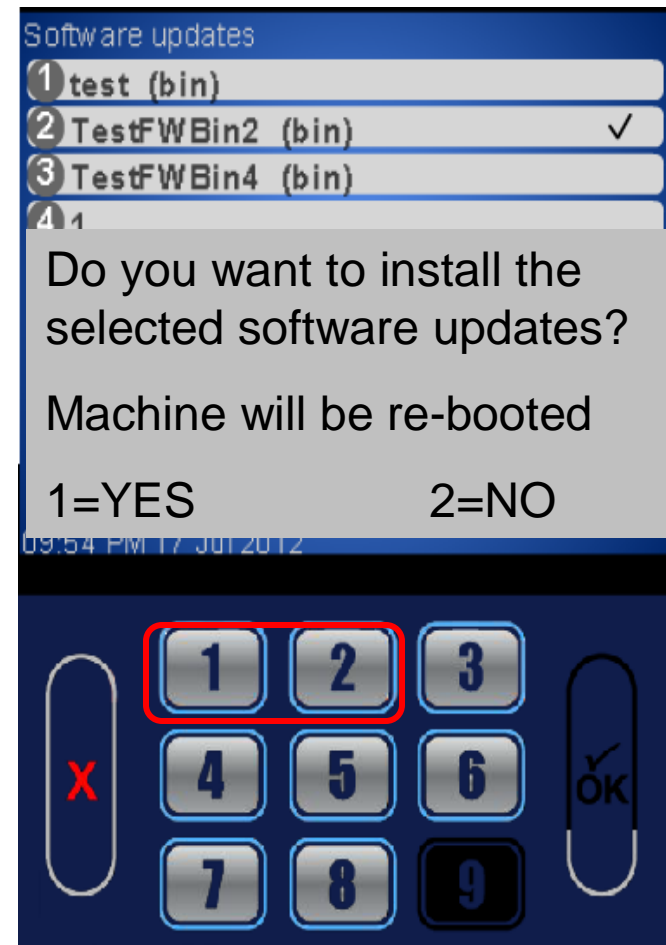



System Settings Backup / Restore

Backup / Restore

- Allows you to backup your current Configuration for recovery later if needed.
- Allows you to restore the machine to factory defaults.
- Allows you to restore the machine to a previously saved configuration
- Backups are saved with date created.
- Backups are stored on the controller, not removable media.

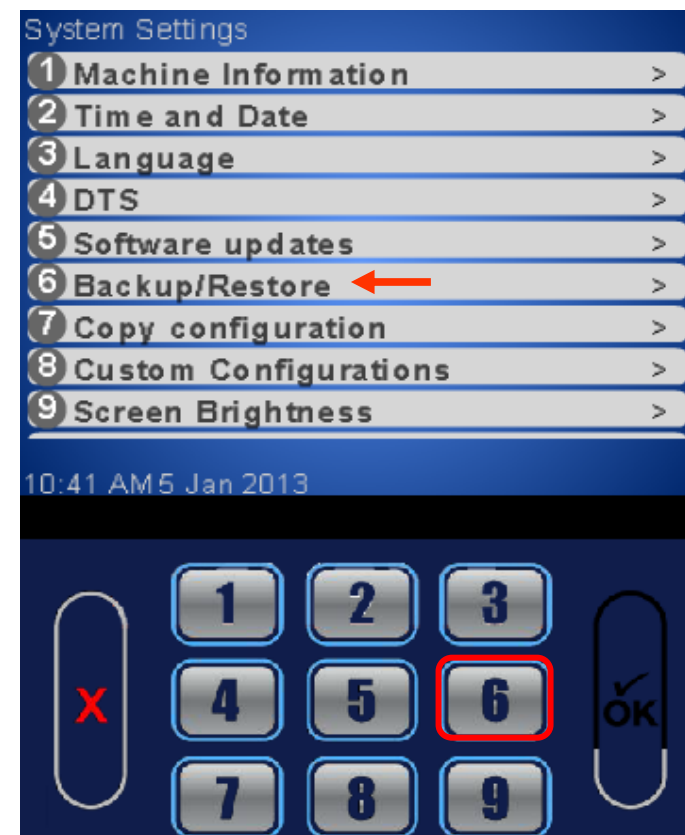



System Settings Backup / Restore

Press 6 to access Backup / Restore

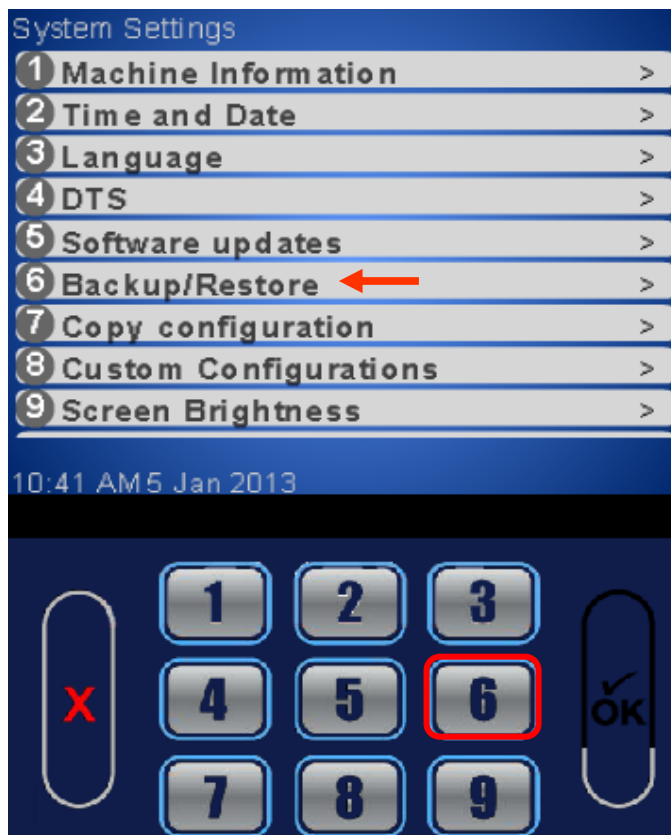

Press 1 to backup your current Configuration for recovery later. All previous backups will be listed. Choose a number on the keypad associated with the backup you want to restore or choose to Restore to the Factory Backup. Press OK to Continue. In this case we are choosing 1 to make a new backup.

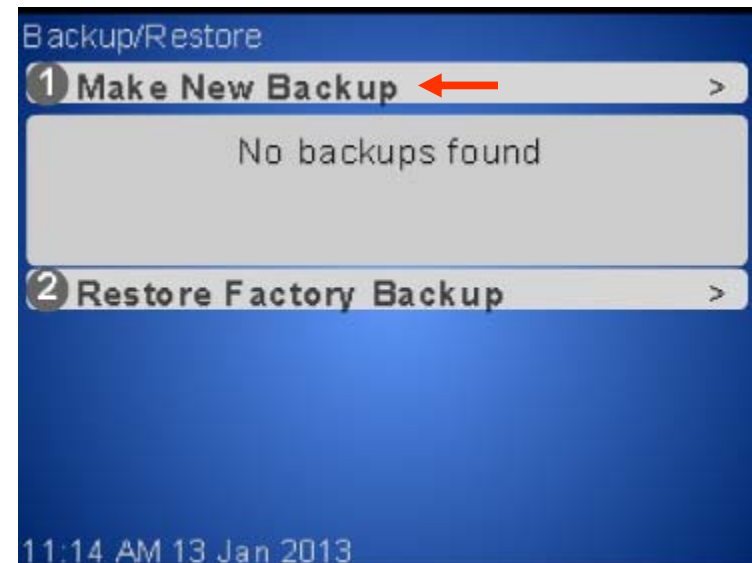



System Settings Backup / Restore

The display show a conformation screen. Choose 1 to continue and 2 to back out.

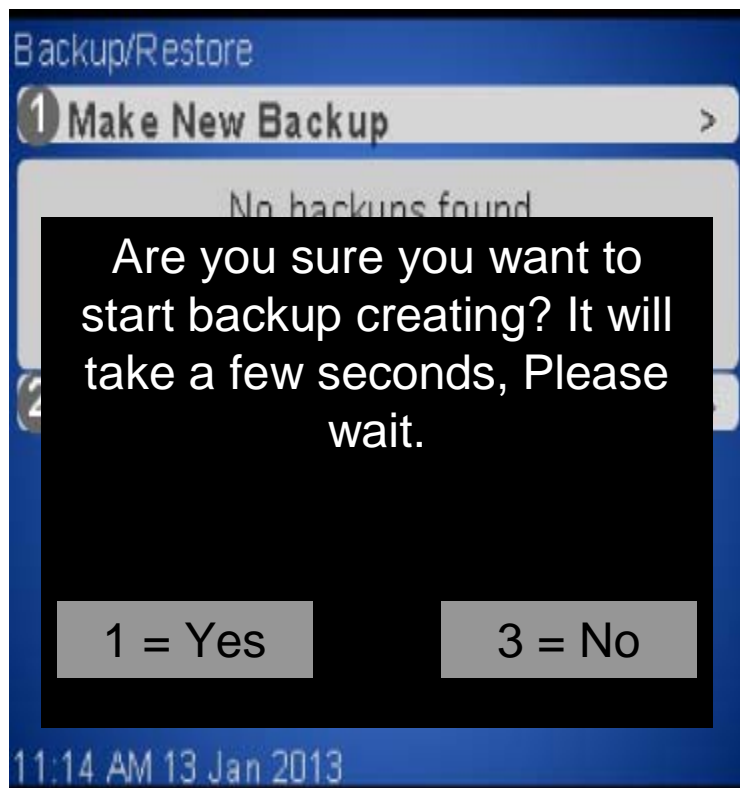

Choosing 1 for yes will update the display with the new backup file including the time and date of the backup. This file can be selected at a later date if you want to restore you machine to this backup file.





System Settings

Copy Configuration

Copying an existing Configuration

- This menu allows you to copy a machine that has been set up and save the file on a flash drive.
- Once you have copied an existing configuration (set up) you can load it into other machines.
- For ease of use in the future the files can be named
- Before attempting to clone an existing machine Configuration you must create a folder on your USB flash drive named atlas.
- You can have unlimited configurations in the atlas folder.
- Plug a flash drive in to the control board on USB3 (the one on the bottom all by itself).

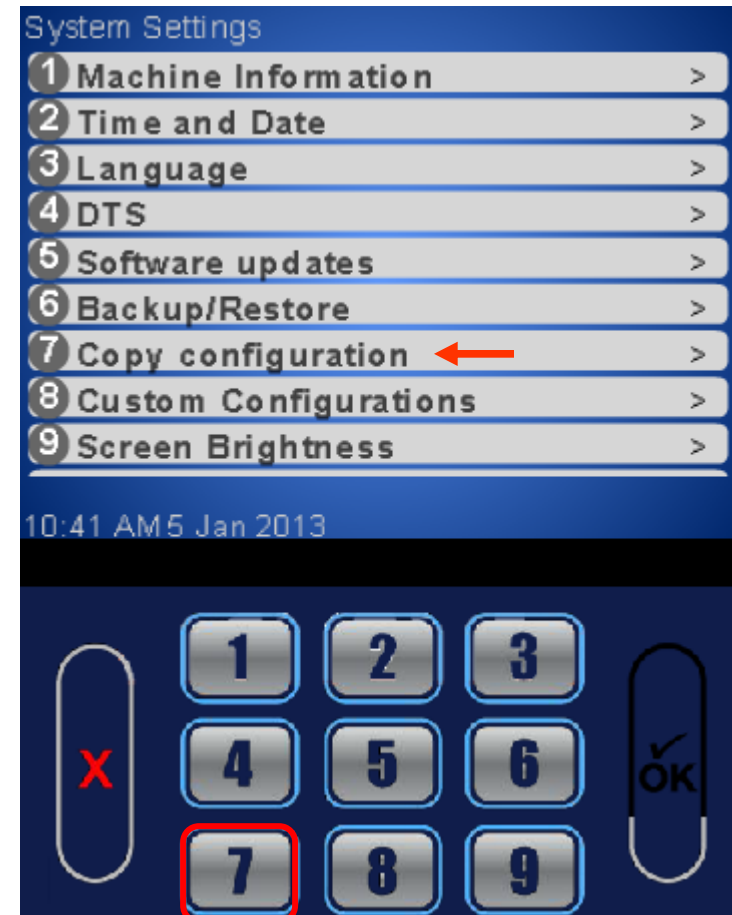



System Settings Copy Configuration

Preparing the Flash drive

The files size is less than 80kb so you can use any size flash drive.

1. Using you computer, create a folder on your flash drive named atlas.
2. Insert the flash drive into USB port number 3 on the control board (bottom one all by itself).
3. Power cycle or reboot the machine with the flash drive installed.
4. Enter PIN 3333
5. Press 8 for system settings, the 7 for copy configuration.

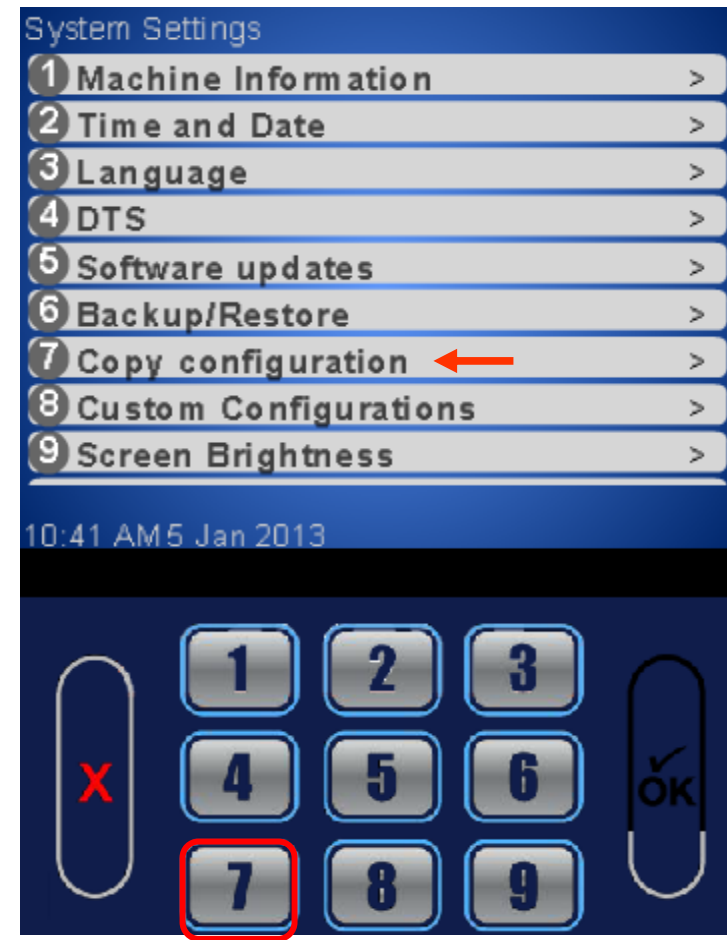

Continued

Copy Configuration – Create Configuration Clone

If the Flash Drive is not found you will see the screen below.

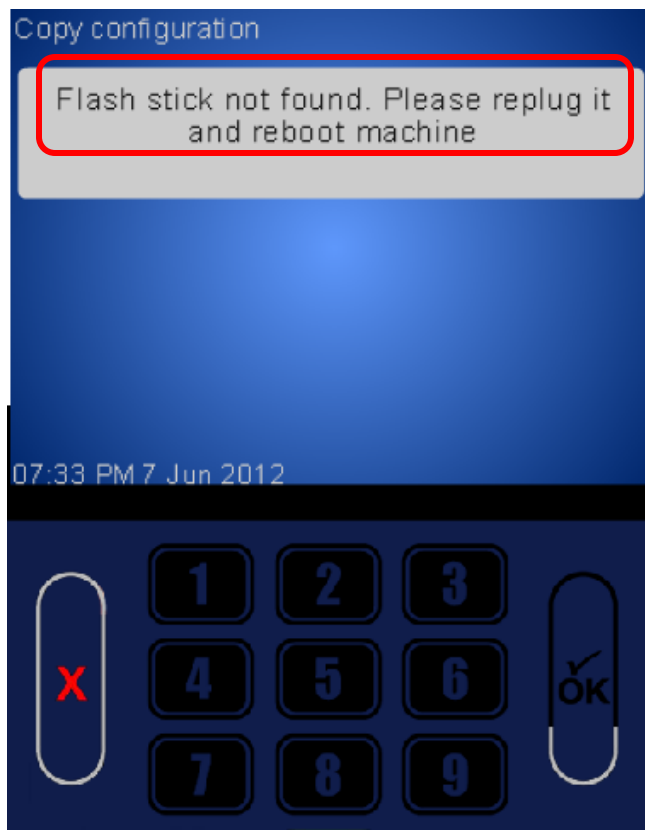

Choose 1 to Create a Configuration Clone (from the control board to the stick). If there are existing clone file on the flash drive they will show up below Create Configuration clone and can be chosen to be uploaded to the machine.

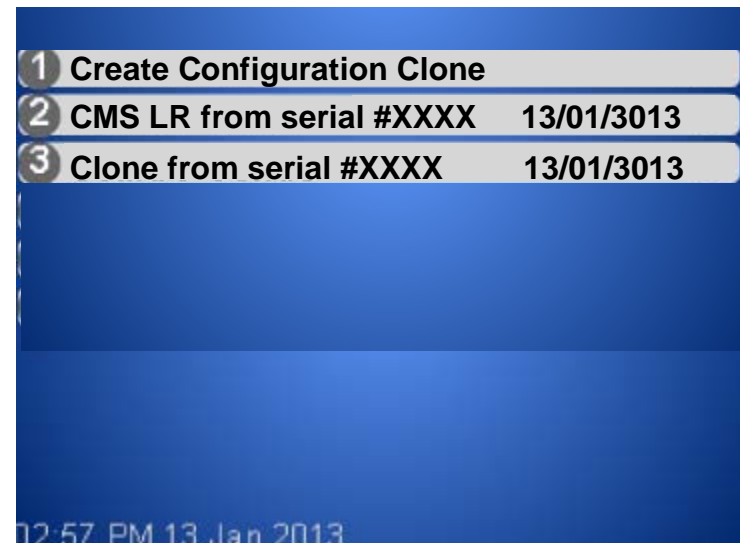

Continued →

Copy Configuration – Create Configuration Clone

Press 1 to create a clone file on the stick that can be copied to another machine

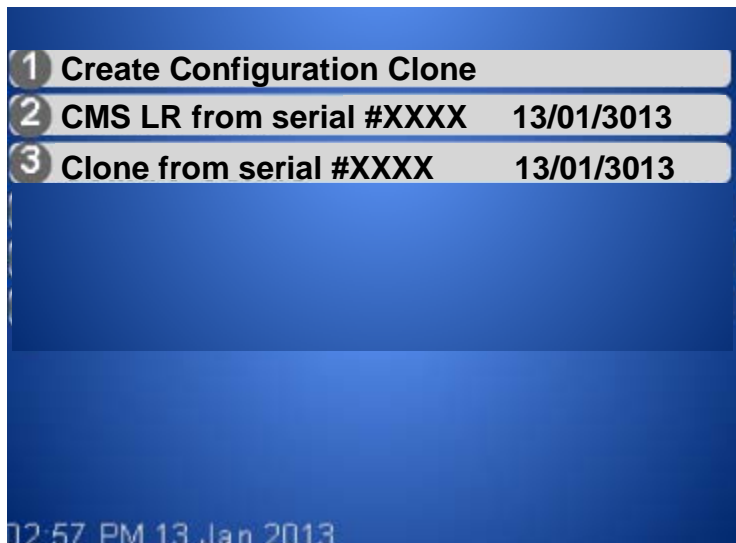

Select 1 to name the configuration. Naming the configuration is optional.

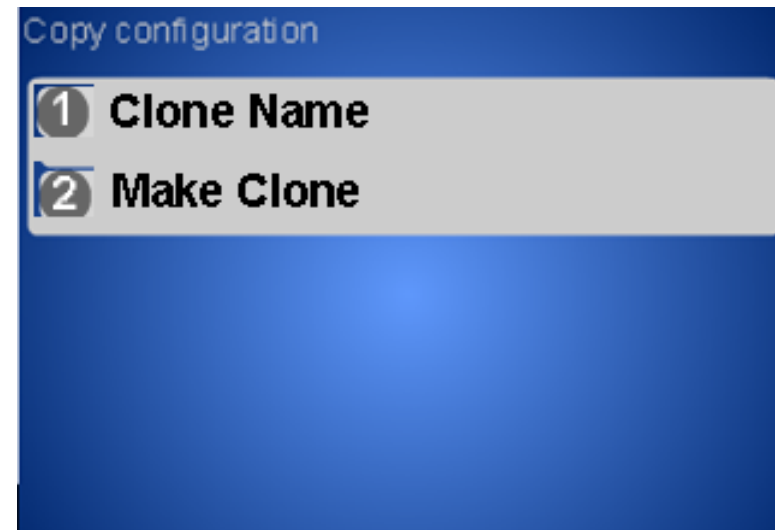

Select 2 to copy without naming





System Settings

Copy Configuration

- A numeric box will appear as a reference for the numbers to push on the keypad.
- As an example if you want to enter the letter b you would press button 2 twice.
- Pressing  on the keypad will change the reference box between numbers letters and caps.
- The  is the backspace key.
- Once the message is entered press OK.

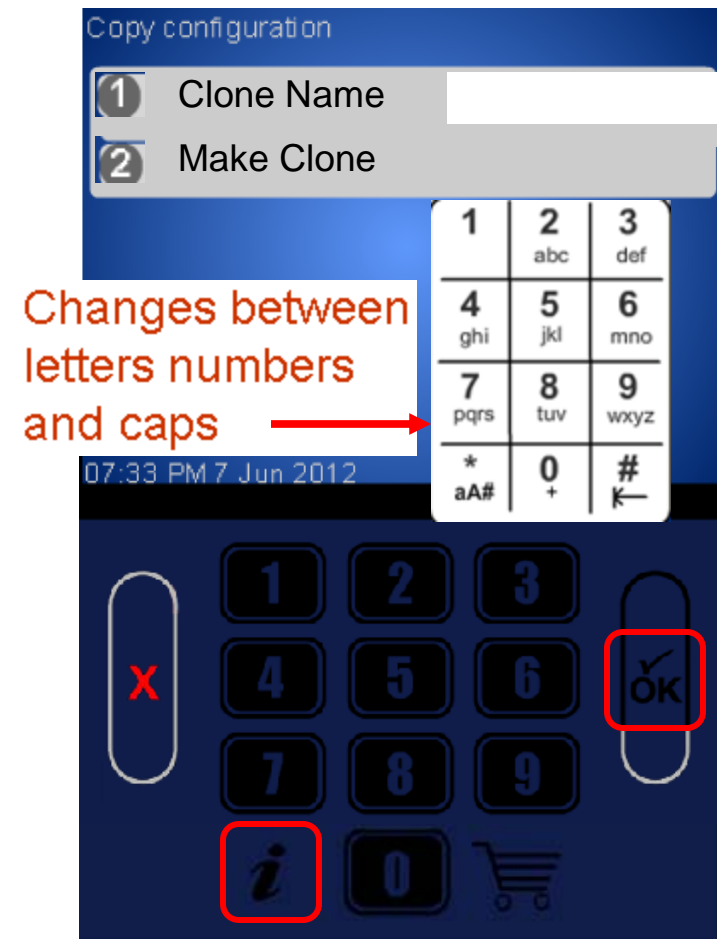



System Settings

Copy Configuration

Press 2 to make clone, a
confirmation box will
appear

Press 1 to continue or 3
to cancel

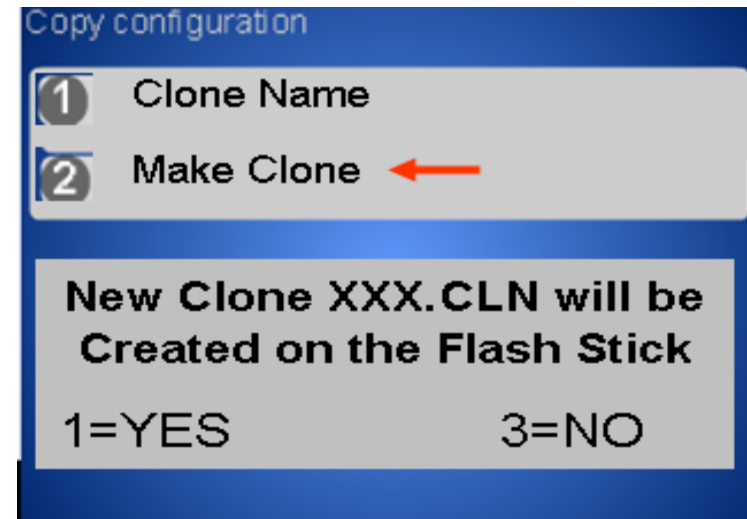
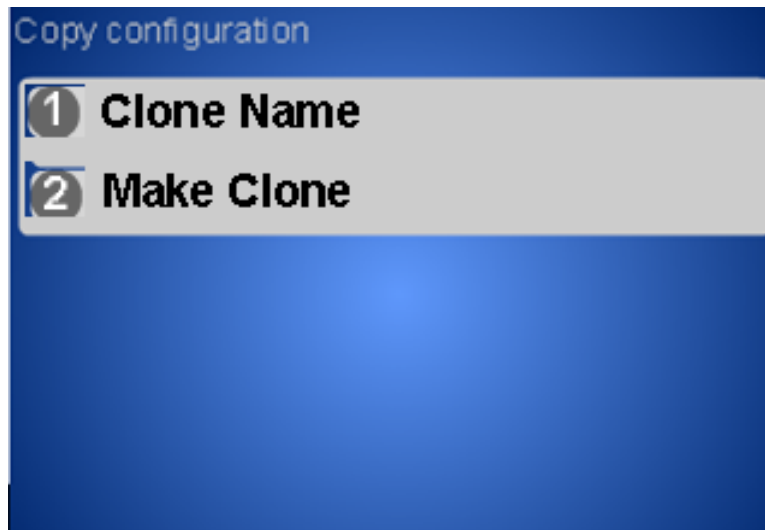



System Settings

Copy Configuration – Uploading from a Flash

All files listed below Create Configuration Clone are valid configurations that can be copied from the flash stick to the control board. Press an index number to upload or delete the file.

Press 1 to install the file or 2 to delete the file from the Flash.

A confirmation box will appear verifying you want to install or delete the file, press 1 to continue or 2 back out.

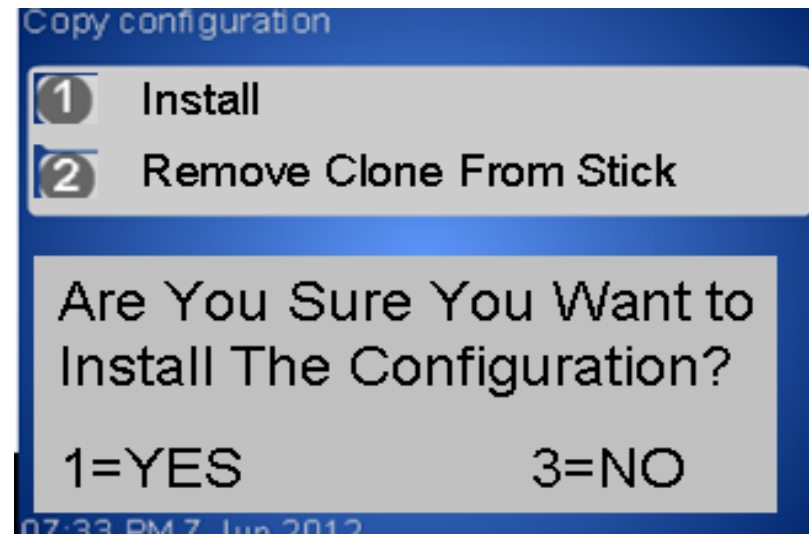
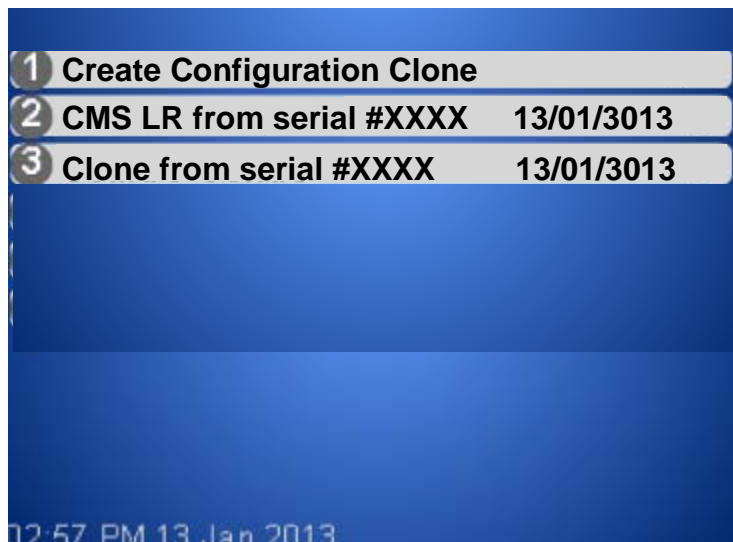



System Settings

Screen Brightness

Press 2 to set the Screen Brightness

Press 1 to change the Brightness, the higher the number the Brighter the screen. Enter a number and press OK. Followed by 2 to save.

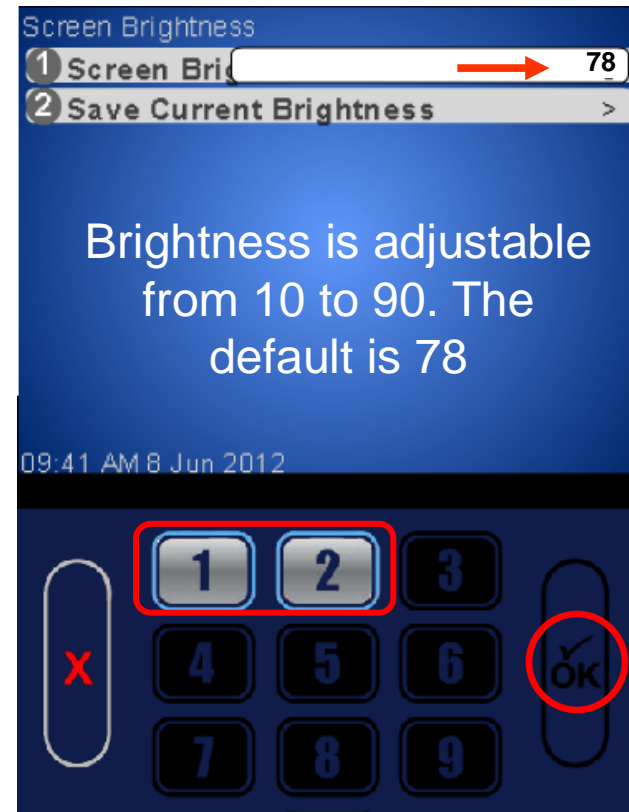



System Settings

LED Color

Press the highlighted lower half of the OK button to scroll down to LED Color

Press 3 to change the LED Color. This Menu allows you to change the standby color of the pill surround and payment devices?

Press 1,2 or 3 on the keypad to change the color, followed by OK.

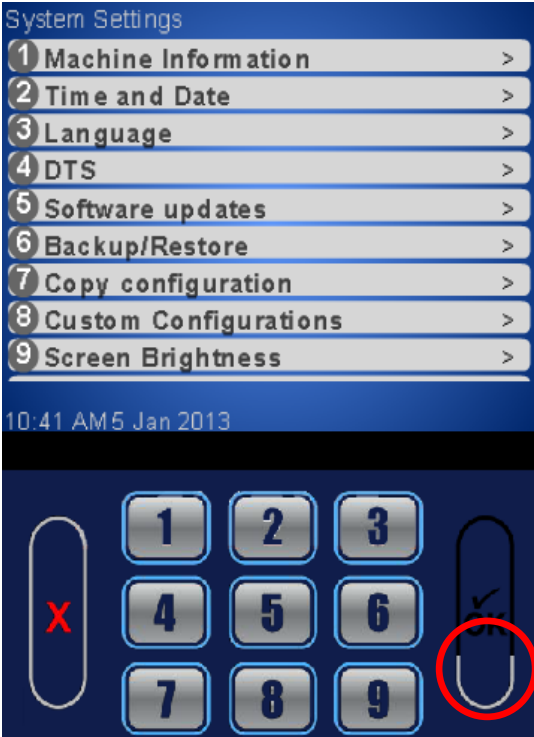



System Settings

Idle Timeout

Idle Timeout

- If a person starts a transaction on the machine and walks away without pressing the **X** key, the idle timeout is the amount of time until the machine goes back to its standby message routine.
- The Idle Timeout is settable from 15 to 180 seconds.
- The factory default for the Idle Timeout is 30 seconds.



Continued →



System Settings

Idle Timeout

Press the highlighted lower half of the OK button to scroll down to LED Color

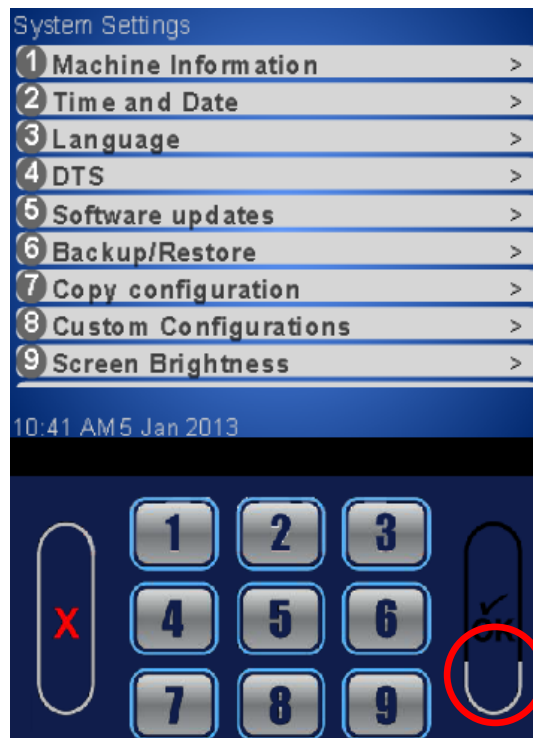

Press 3 to change Idle message timeout. The default is 30 seconds



Use the numeric keypad to enter a new time followed by OK

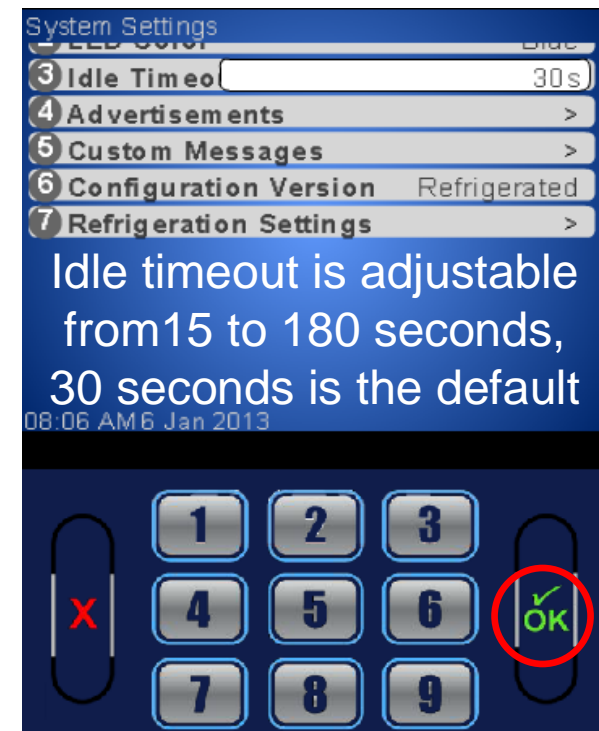



System Settings

Advertisements

Advertisements

This menu allows the user to turn on and off messages that are shown to the consumer during the idle screen loop.

The messages that can currently be turned on and off are:

- Selection Information
- Money
- Cards
- This Menu also allows you to choose what credit cards logos are displayed as available for use on the idle message screen.



Continued



System Settings

Advertisements

Press the highlighted lower half of the OK button to scroll down to LED Color

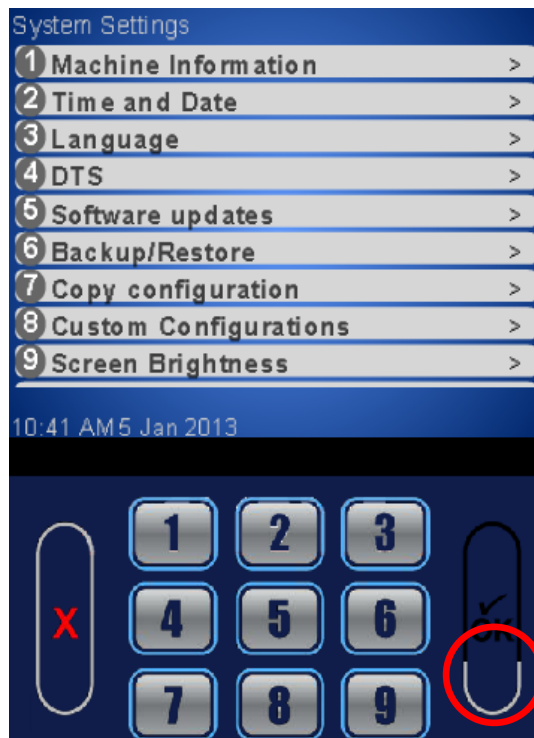

Press 4 to modify messages shown on the idle screen loop.

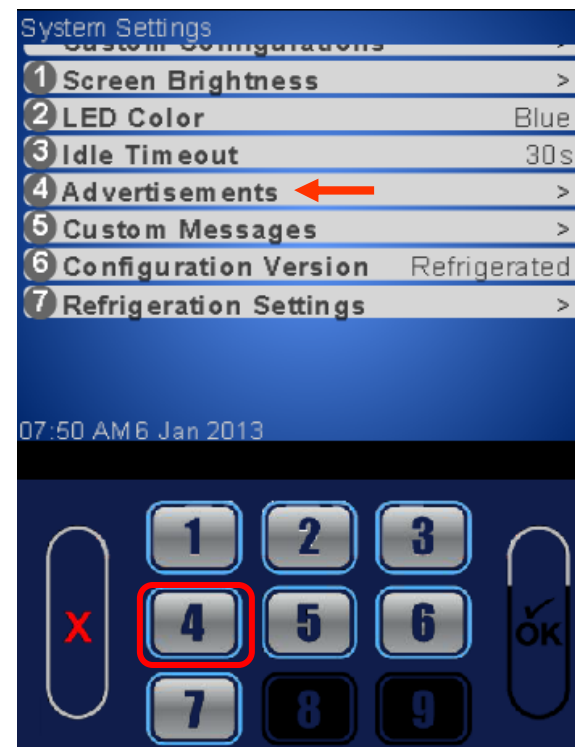



System Settings

Advertisements

Press 1- 4 to on the keypad to add or remove a checkmark. Items with a checkmark will be shown on the Idle Screen Loop. Select 5 to go to the next screen for credit card types accepted

Press 1- 4 to on the keypad to add or remove a checkmark. Items with a checkmark will be shown on the Idle Screen Loop. Selecting 5 will show a generic picture of a credit card in the idle loop.

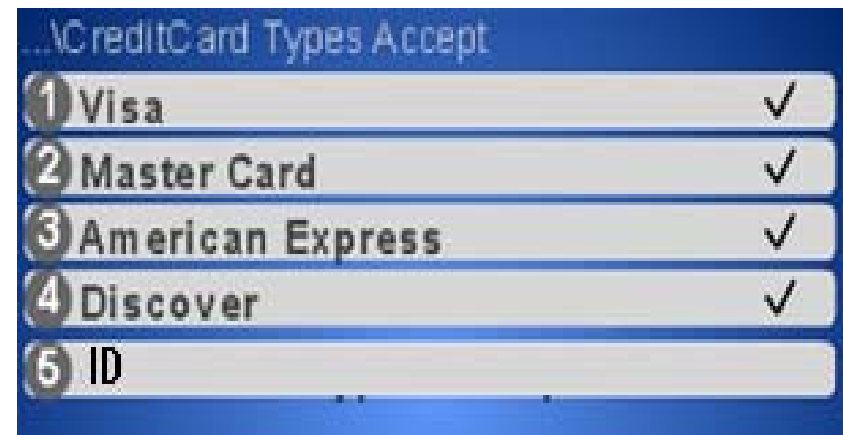



System Settings

Custom Messages

Custom Messages

- This menu gives the user the option to both create and enable messages for both the Idle screen and the vending screen independently.
- These Messages can be Text or numeric based.



Continued →



System Settings

Custom Messages

Press the highlighted lower half of the OK button to scroll down to LED Color

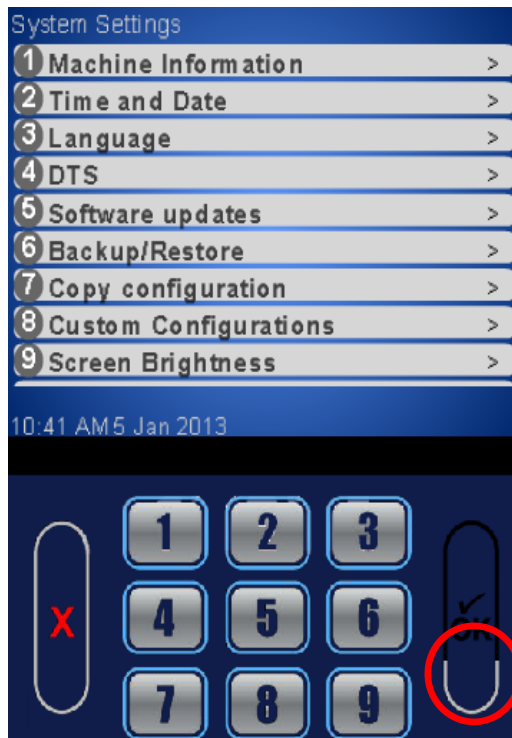

Press 5 to create, change or assign a Custom Message

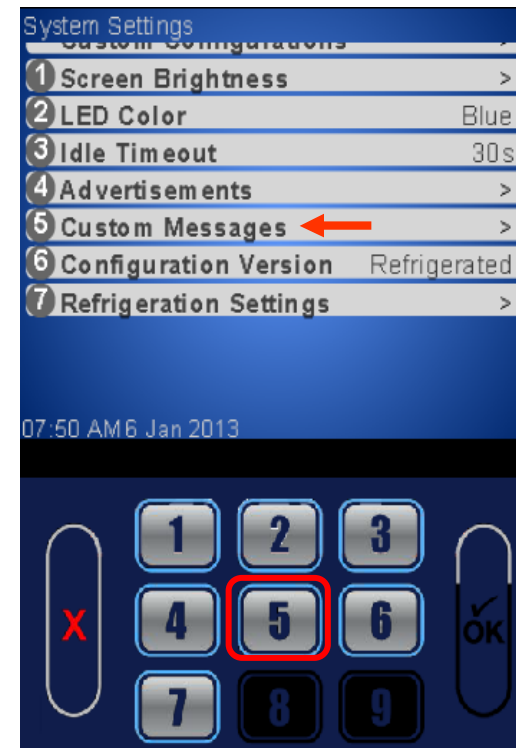



System Settings Custom Messages

Press 1 or 2 add a checkmark to turn on a custom message. Adding a checkmark will automatically bring up the next screen →



Press 2 or 4 to edit or create your Custom Message. See the details on the next slide





System Settings Custom Messages

- A numeric box will appear as a reference for the numbers to push on the keypad.
- As an example, if you want to enter the letter b you would press button 2 twice.
- Pressing **i** on the keypad will change the reference box between numbers letters and caps.
- The  is the backspace key.
- Once the message is entered press OK.

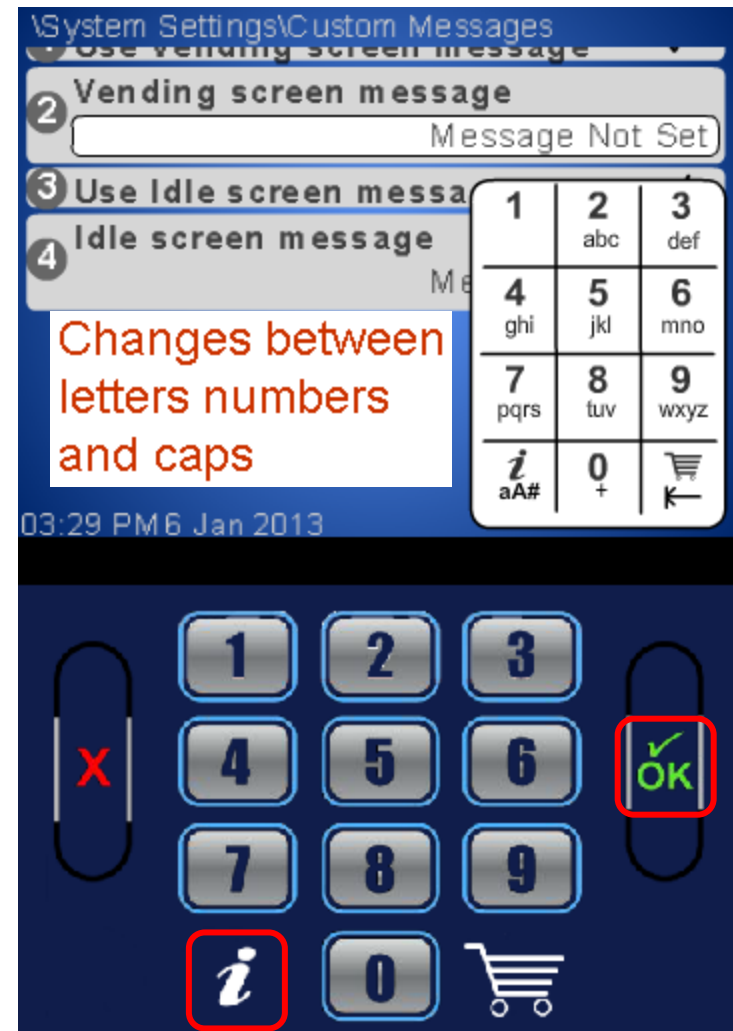

Continued →



System Settings Configuration Version

Setting the Machine Type

- Your choices are Ambient, refrigerated, non Perishable or chilled in the Configuration Version Menu for the Refrigeration Settings Menu to appear in the System Settings Menu.
- Ambient will always be selected when a refrigeration unit is not present.
- When Refrigerated Merchant is chosen the temperature is settable from 33-38°F (1-3°C) and the health control menu will be available.
- When Non Perishable is chosen the temperature is settable from 33-45°F (1-7°C) and the health control menu will be not available.
- When Chilled is selected the settable temperature range is from 49-69°F (9-21°C) and the health control menu will **not** be available.





System Settings Configuration Version

Pressing 8 from the main menu will take you to the System Settings Menu. Press the bottom of the OK button to go to the next menu

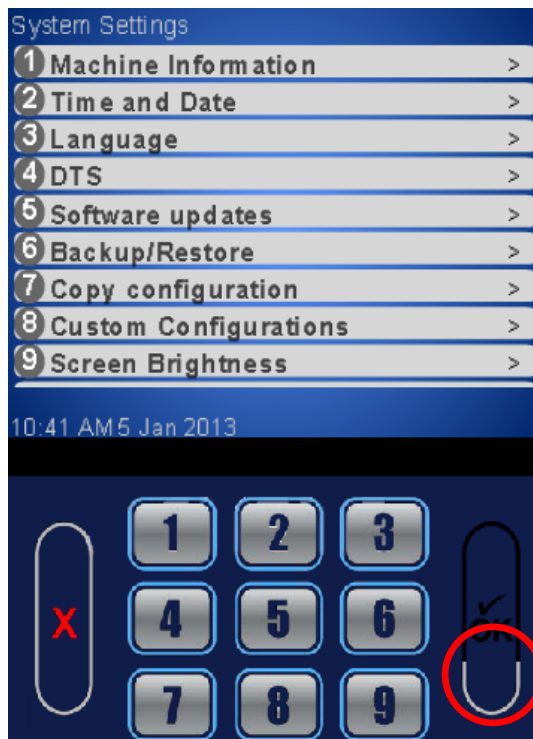

Press 6 to go to Configuration Version

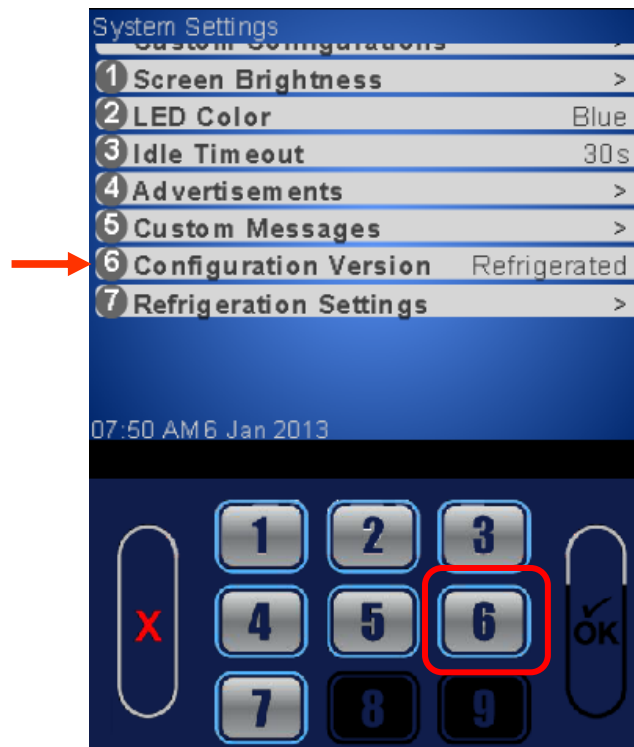

Press 1- 5 to select the desired Configuration Setting. Do not use # 3 in the US. You must press OK to save changes.





System Settings

Refrigeration Settings

Pressing 8 from the main menu will take you to the System Settings Menu. Press the bottom of the OK button to go to the next menu

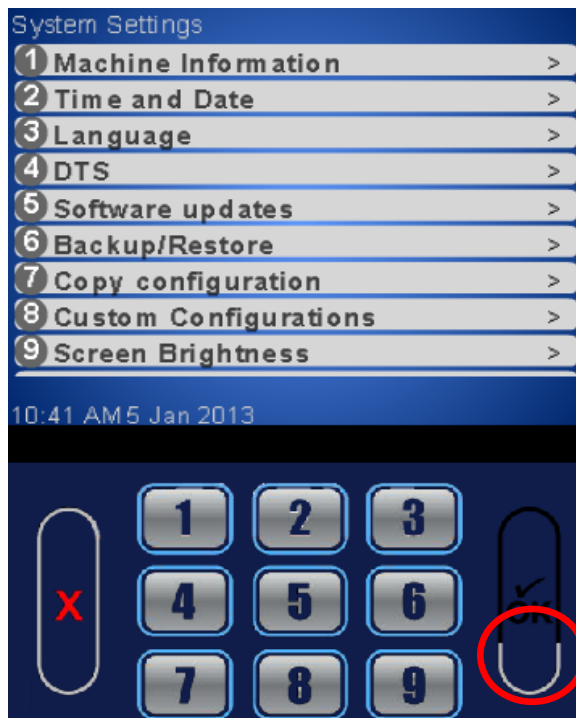

Press 6 to go to Refrigeration Settings, this menu will not appear when the Configuration setting is Ambient.



Press 1- 5 to set the Refrigeration Settings. This menu should already be set from the factory.





System Settings

Refrigeration Settings – Adjust Temperature

Setting the Temperature Range

- In Ambient machines this menu will not appear.
- Refrigerated temperature is settable from 33-38°F (1-3°C) and the health control menu will be available.
- Non Perishable temperature is settable from 33-45°F (1-7°C) and the health control menu will be not available.
- Chilled temperature range is from 49-69°F (9-21°C) and the health control menu will not be available.

Press 1 on the keypad to Adjust the Temperature



On the keypad enter the desired Temperature followed by OK





System Settings

Refrigeration Settings – Temperature Units

Press 2 on the keypad to change the viewable Temperature between Fahrenheit and Celsius

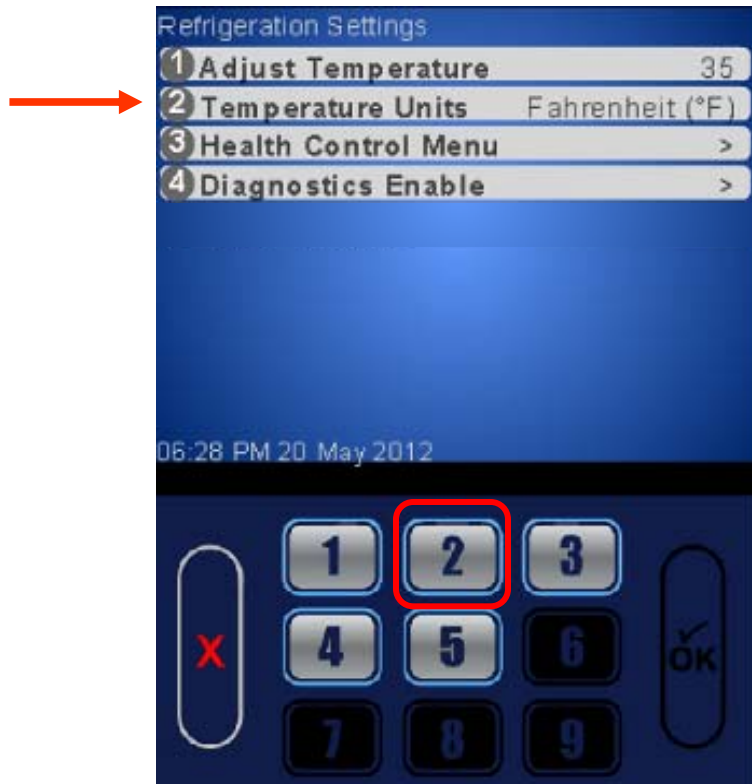

On the keypad press 1 for Fahrenheit 2 for Celsius, followed by OK

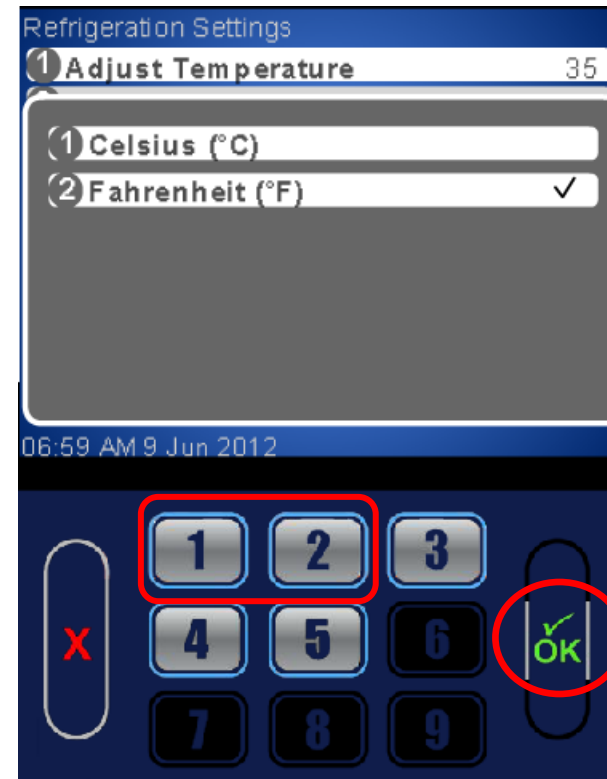



System Settings

Refrigeration Settings – Health Control

Press 3 on the keypad to access the Health Control Menu



On the keypad press the tray number you wish to view or change

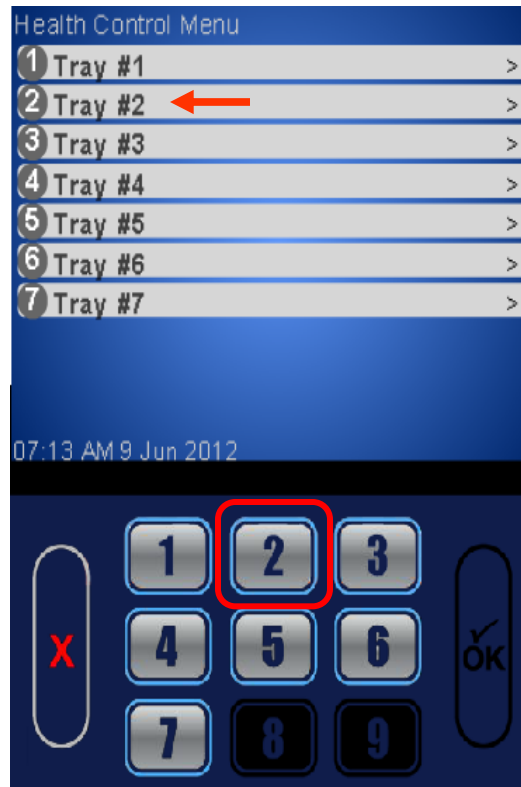

All available selections are shown. Use the keypad to add a checkmark to the motors that are active for Health Control.





System Settings

Refrigeration Settings – Diagnostics enable

The Diagnostic Enable menu allows you to turn on or off the errors reported by the evaporator sensor and condenser sensor. These errors are reported when the door is opened if they exist. The default is on for both warnings & errors

High Side errors & warnings are created when the **Condenser Outlet Sensor** is out of Range, most likely due to blocked inlet screen, dirty condenser, or condenser fan failure

- **Warning:** If the **Condenser Outlet Sensor** is greater than 125F for the 30 MINUTES.
- **Error:** If the **Condenser Outlet Sensor** is greater than 150F for 5 minutes, **cooling is disabled. The error will need needs to be manually reset.**

Low Side errors & warnings are created when the unit goes into Low-Temp Defrost; where the **Evaporator Coil Sensor** is less than 10F too frequently . Most likely due to an obstructed evaporator coil, low charge, or an evaporator fan failure.

- **Warning:** If the unit goes into Low-Temp Defrost (10F) in more than 5 minutes, but less than 75 minutes after a previous defrost cycle.
- **Error:**, If the unit goes into Low-Temp Defrost (10F) in less than 5 minutes after a previous defrost cycle, **cooling is disabled. The error will need needs to be manually reset.**

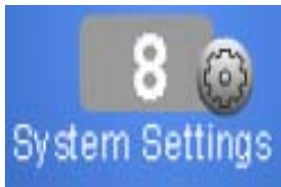

System Settings

Refrigeration Settings – Diagnostics Enable Menu

Press 4 on the keypad to Access the Diagnostics Enable Menu



Each Warning or Error can be turned off individually by selecting 1- 4 on the keypad

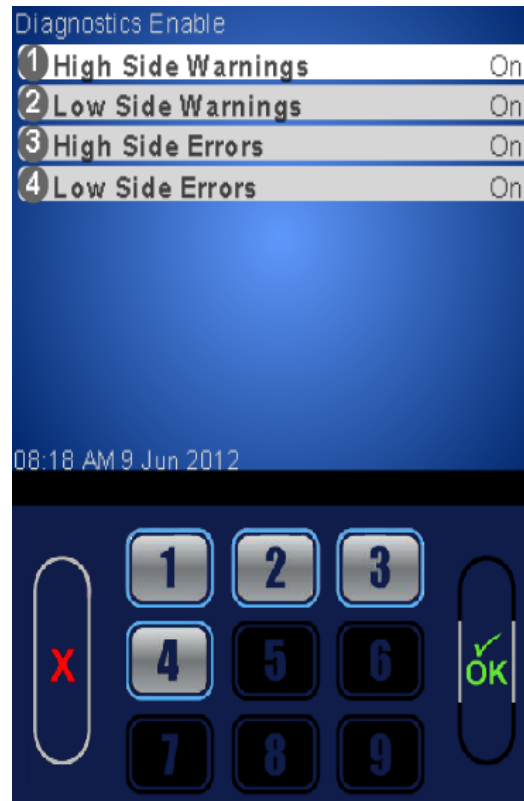

On the keypad enter 1 for Off or 2 for On, followed by OK

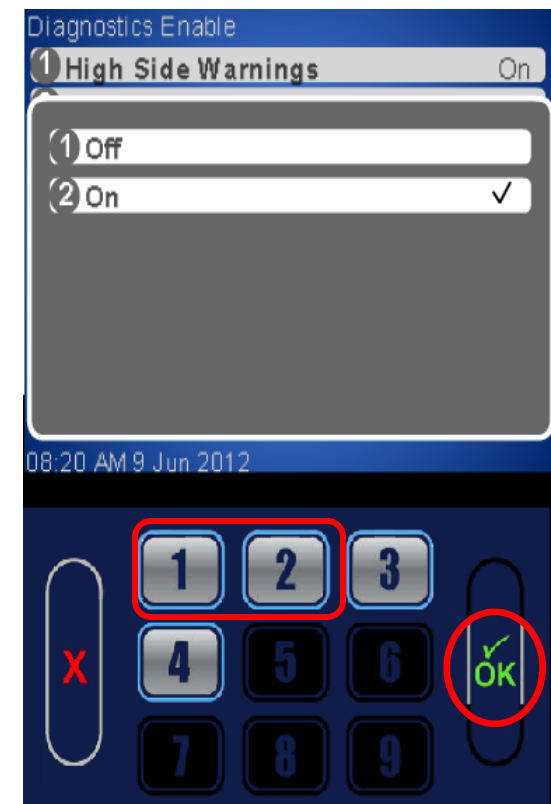



Security Codes

The Security code menu

- The first menu item allows you to enter an existing Pin number.
- The second and third menus allows you to change the existing Pin numbers.
- **Warning:** If you change the pin, don't forget it, you won't be able to access the menu's.





Security Codes

Enter Pin

Press 1 on the keypad to
Enter the existing pin

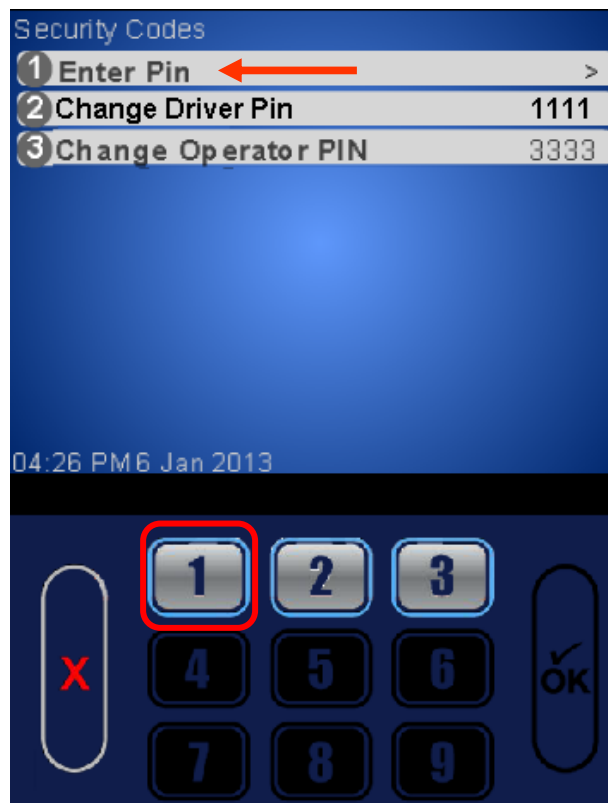

The Pin screen will appear,
enter your existing PIN
followed by OK

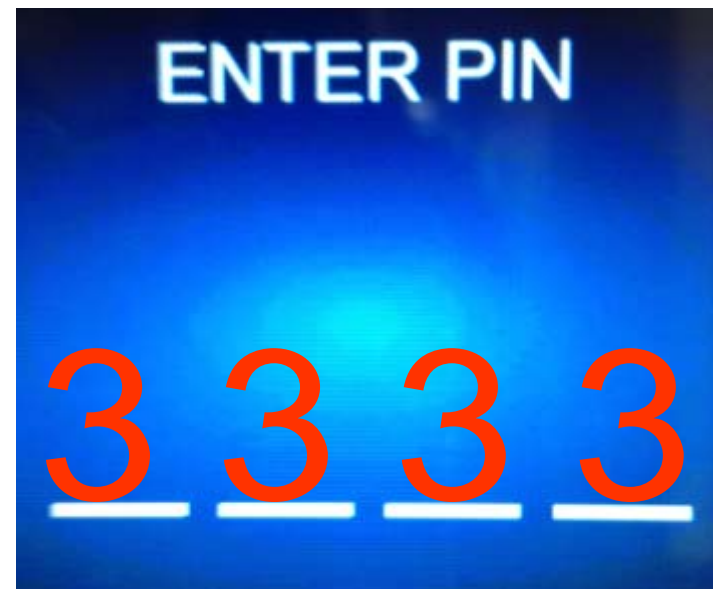



Security Codes

Change Driver or Operator Pin

Press 2 or 3 on the keypad to change the existing PIN number



Enter your new Pin Number on the keypad, followed by OK

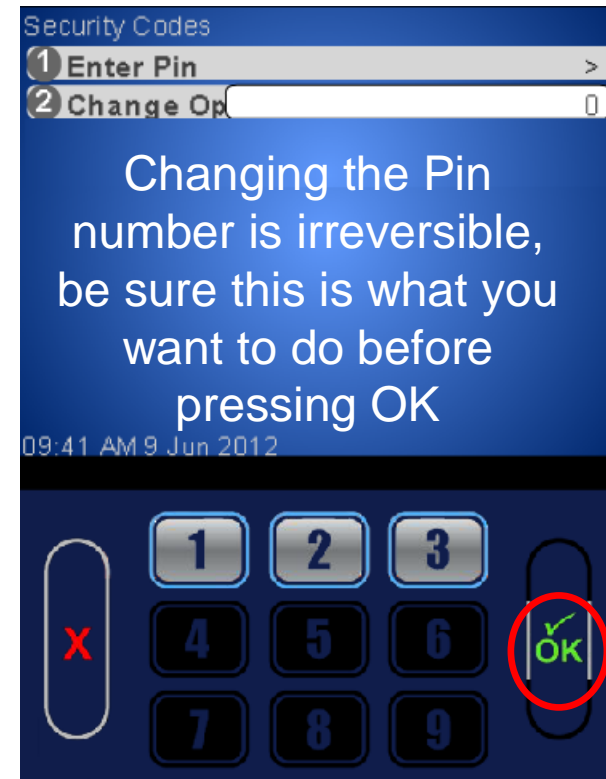



Timed Events

Timed Events

In the Timed Events Menu you to can:

- Create Time of Day Events
- Backup your Current Events
- Create Power Saving Events





Timed Events

Time of Day Events

Timed of Day Events

- There are 3 different time of day events
 - Price Adjust
 - Free Vend
 - Inhibit
- Price Adjust has two menus not used in other events, those menus are:
 - Price Adjust Type
 - Price Adjust Percentage

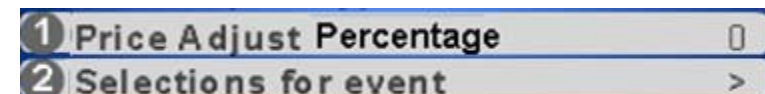
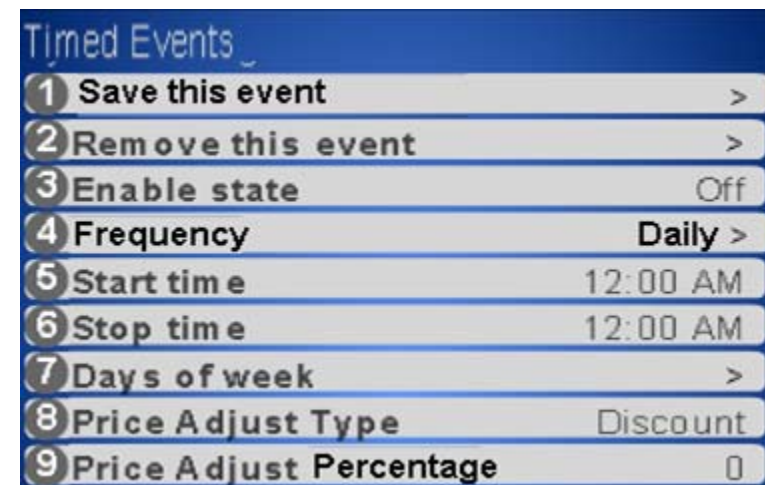



Timed Events Backup Events

Backup Events

- The backup Events Menu allows you to create backups of the events you have created.
- This Menu allows you to program the time and day or days you wish to back up the Events

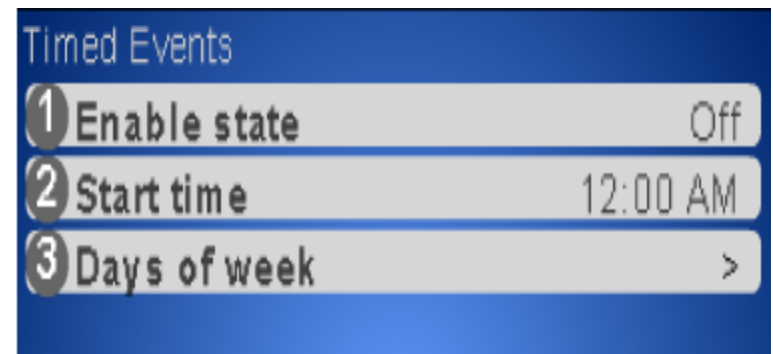
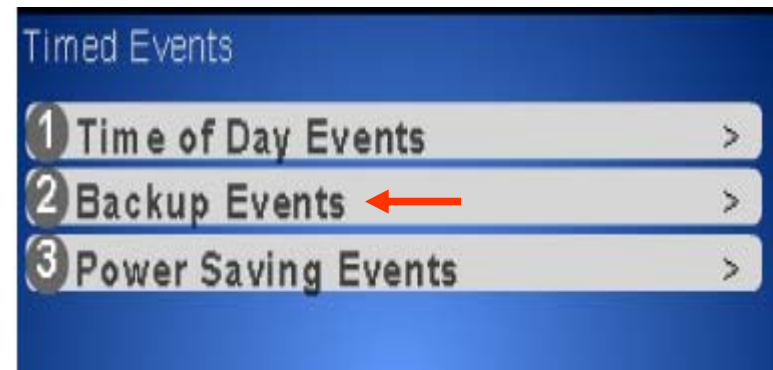



Timed Events

Power Saving Events

Power Saving Events

- The Power Saving Events Menu allows you to create events where the lighting will turn off to save energy.
- This Menu allows you to program the time and day or days you wish the Power Saving Events to be active.
- There is one additional feature that is only in the Power Saving Events Menu. This feature allows you to set the minutes of inactivity before the machine goes into Power Saving Mode.
- Inactivity minutes are settable from 1 to 600.

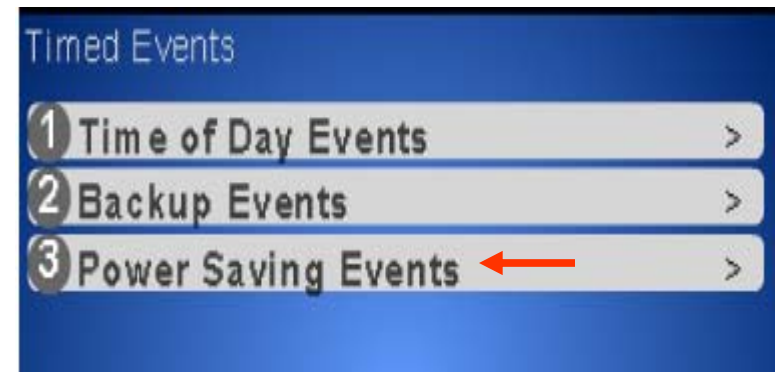



Timed Events

Power Saving Events

Helpful Hints

- All events will not have the same menus. As an example, a Price Adjust Event will have a discount feature that a Power or Backup event would not have.
- Because all events don't have the same number of menus, **this manual may say press 3 and it may be 4 in your event.** Go by the number on your display.
- Because Events are settable by the day of the week they **must not cross over midnight.** As an example, if you were to set a power event from 10:00 PM to 6:00 AM that would be two separate events. The first from 10:00 PM to 11:59 PM and the second from 12:00 AM to 06:00 AM.
- All Events will have a save this event feature as # 1 on the menu. This is used to save the event after you have set all the other menus in an event. **SAVE OFTEN!**
- If your event has a large menu that continues on to a second screen, **use the upper half of the OK button to scroll back up to the first screen to save.** If you use the exit key you will be starting over.



Timed Events

Create New Event

Choose the Type
of event you wish
to Create

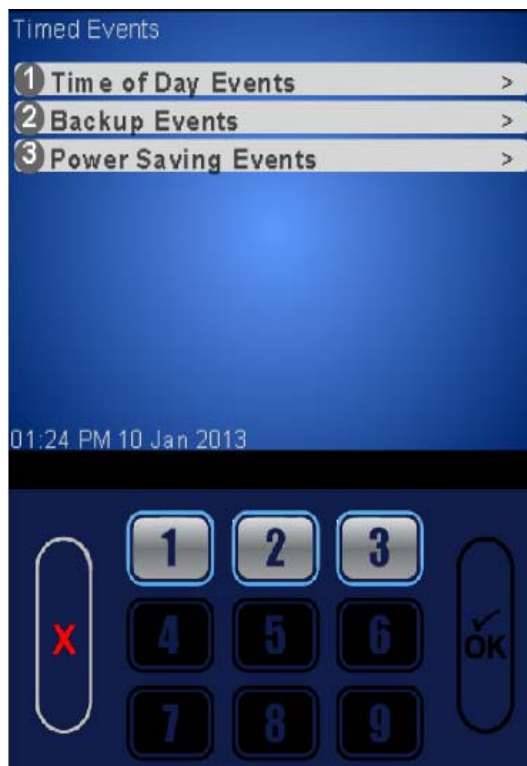

On the Keypad press 1 to
create a new event or
select an existing event
to modify.

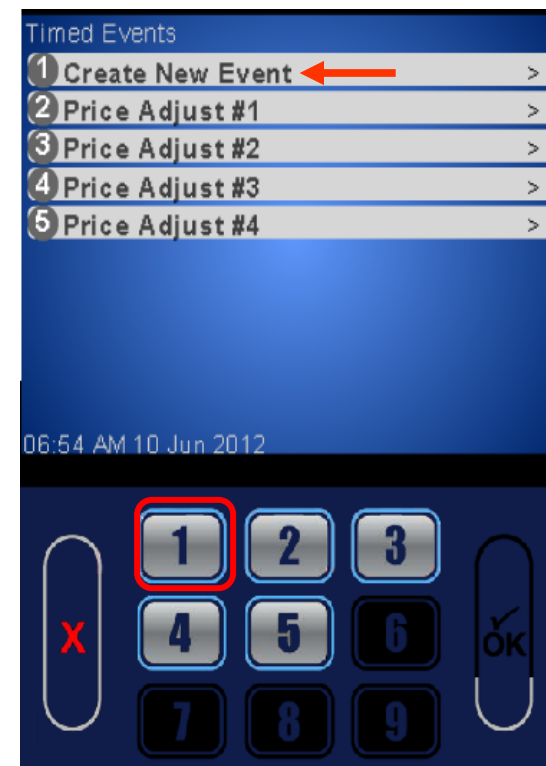



Timed Events

Create New Event

Saving an event is something you will want to do frequently. After programming 3-9 choose 1 to save or your work will be lost.

Choose 2 to remove an existing event you are working on. **Be aware if you remove event 1 and you have multiple events, what was event 2, now will become event 1. Also there is no conformation screen for removing an event so be careful!**

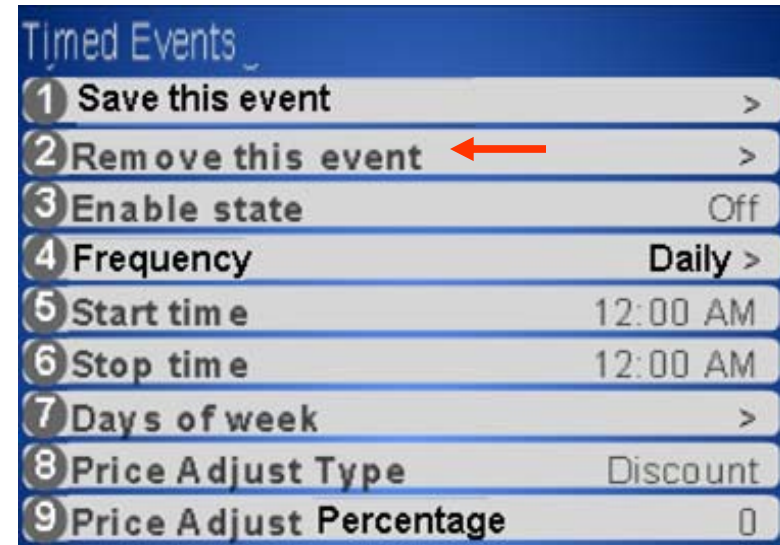
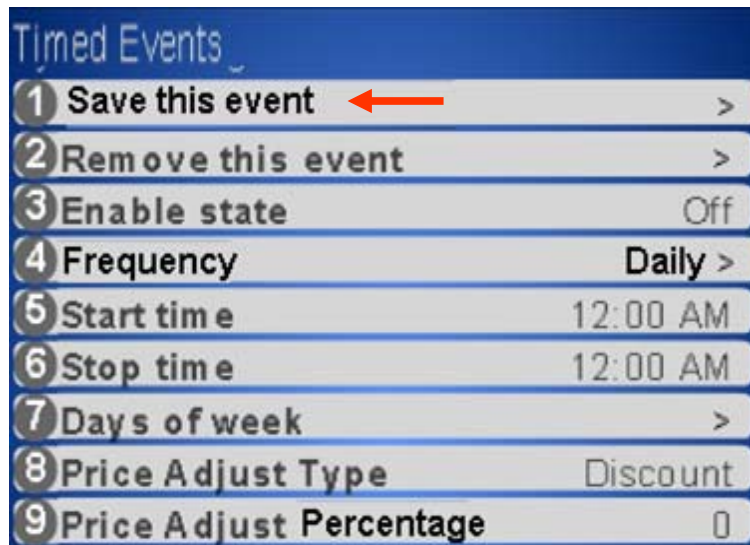



Timed Events

Enabling & Frequency of the Event

Press 3 on the keypad to toggle the state of the event between Off and On. Choosing off allows an event to remain stored in the machine for future use – it is not necessary to Remove the event.

Press 4 on the keypad to toggle the Frequency of the event between Daily and Weekly.

| Timed Events | |
|---------------------------|----------|
| 1 Save this event | > |
| 2 Remove this event | > |
| 3 Enable state | Off |
| 4 Frequency | Daily > |
| 5 Start time | 12:00 AM |
| 6 Stop time | 12:00 AM |
| 7 Days of week | > |
| 8 Price Adjust Type | Discount |
| 9 Price Adjust Percentage | 0 |

| Timed Events | |
|---------------------------|----------|
| 1 Save this event | > |
| 2 Remove this event | > |
| 3 Enable state | Off |
| 4 Frequency | Daily > |
| 5 Start time | 12:00 AM |
| 6 Stop time | 12:00 AM |
| 7 Days of week | > |
| 8 Price Adjust Type | Discount |
| 9 Price Adjust Percentage | 0 |



Timed Events

Frequency of the Event

Note: When you choose Daily you have a choice of a start time, stop time and days of the week

Note: When you choose Weekly you have a choice of a start day, start time, end day & stop time. Because there is one additional menu, Price Adjust has moved down.

| Timed Events | |
|---------------------------|----------|
| 1 Save this event | > |
| 2 Remove this event | > |
| 3 Enable state | Off |
| 4 Frequency | Daily > |
| 5 Start time | 12:00 AM |
| 6 Stop time | 12:00 AM |
| 7 Days of week | > |
| 8 Price Adjust Type | Discount |
| 9 Price Adjust Percentage | 0 |

| Timed Events | |
|---------------------|----------|
| 1 Save this event | > |
| 2 Remove this event | > |
| 3 Enable state | Off |
| 4 Frequency | Weekly |
| 5 Start Day | Monday |
| 6 Start Time | 00:00 |
| 7 Stop Day | Sunday |
| 8 Stop Time | 00:00 |
| 9 Price Adjust Type | Discount |



Timed Events

Setting Start Time

Press 5 on the keypad to enter the time you want the event to start. As an example, if this is an inhibit event set for all selections this is the time the machine will stop accepting money.

Use the Keypad to enter the start time for the event. The I button on the bottom left corner of the keypad will toggle between AM and PM if the time setting is not set for a 24 hr clock in system settings. Press OK when finished.

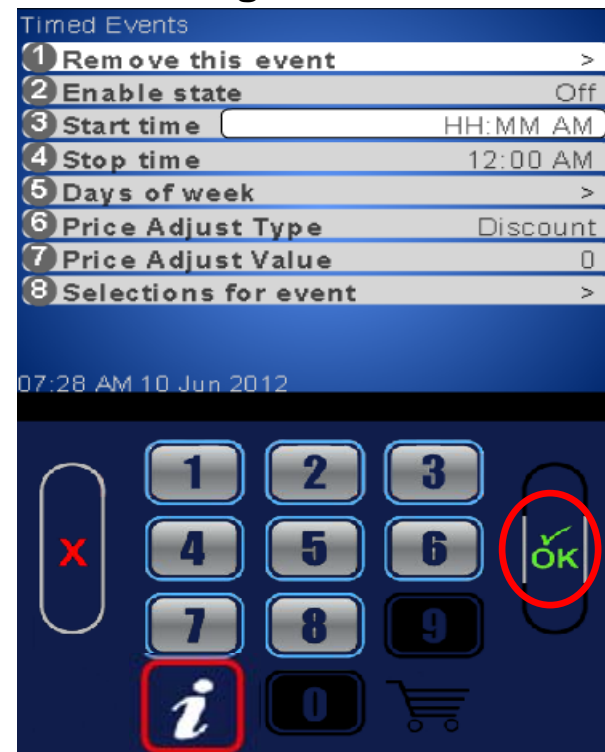
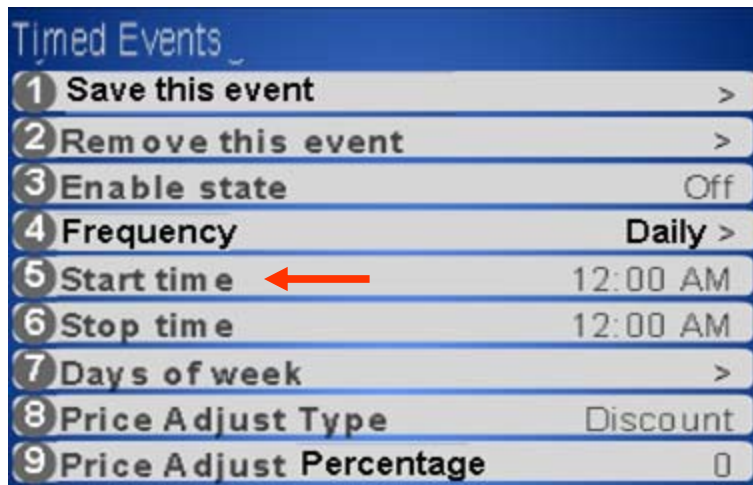



Timed Events

Setting Stop Time

Press 6 on the keypad to enter the time you want the event to stop. As an example, if this is an inhibit event set for all selections this is the time the machine will start accepting money.

Use the Keypad to enter the stop time for the event. The I button on the bottom left corner of the keypad will toggle between AM and PM if the time setting is not set for a 24 hr clock in System Settings. Press OK when finished.

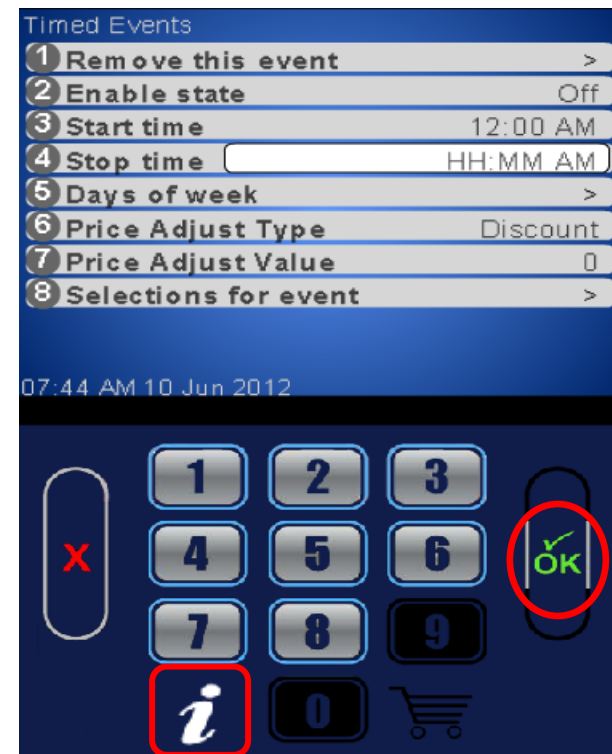
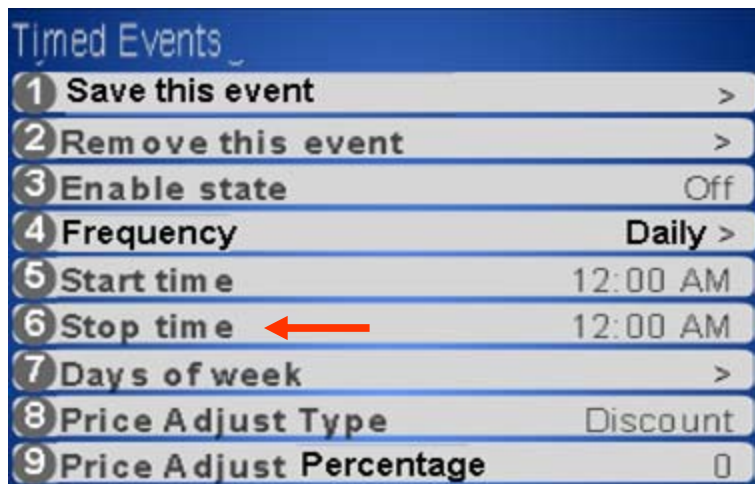

Continued



Timed Events

Days of the week

Press 7 on the keypad to choose the days of the week for the event

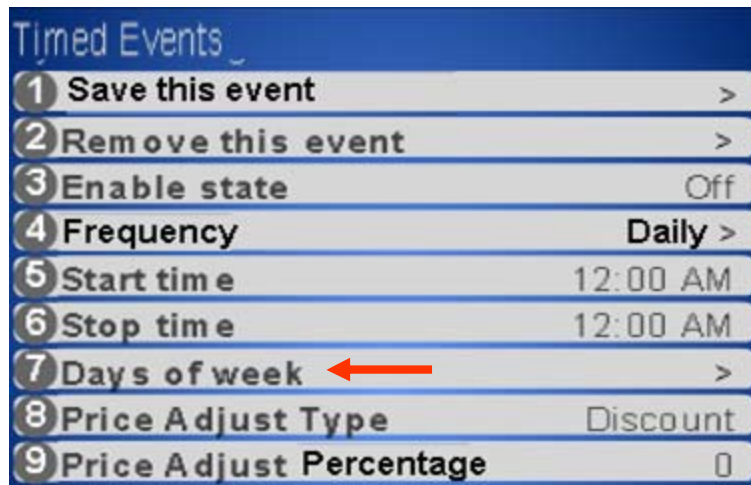

Use the Keypad to add or remove a checkmark to the days of the week you want the event to be active. Press OK when finished. In this example M-F are active.

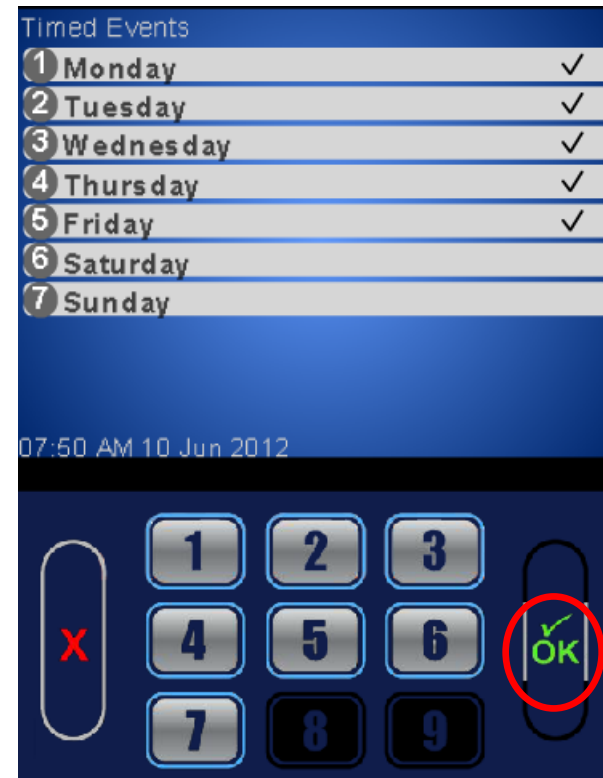



Timed Events Price Adjust Type

Press 6 on the keypad to choose the Price Adjust Type. This menu item is only available for a Price Adjust event.

Use the Keypad select the Price Adjust type for this event. Press OK when finished..

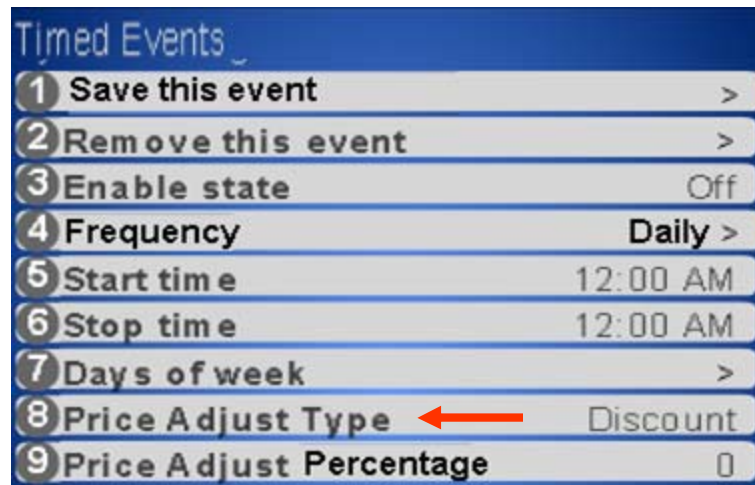



Timed Events

Price Adjust Value

Press 9 on the keypad to choose the Price Adjust Value. This menu item is only available for a Price Adjust event.

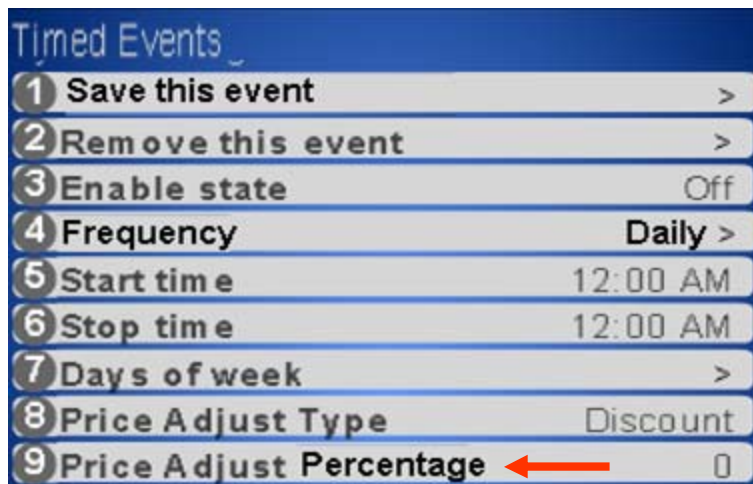

Use the enter the percentage of the discount or surcharge. Press OK when finished.

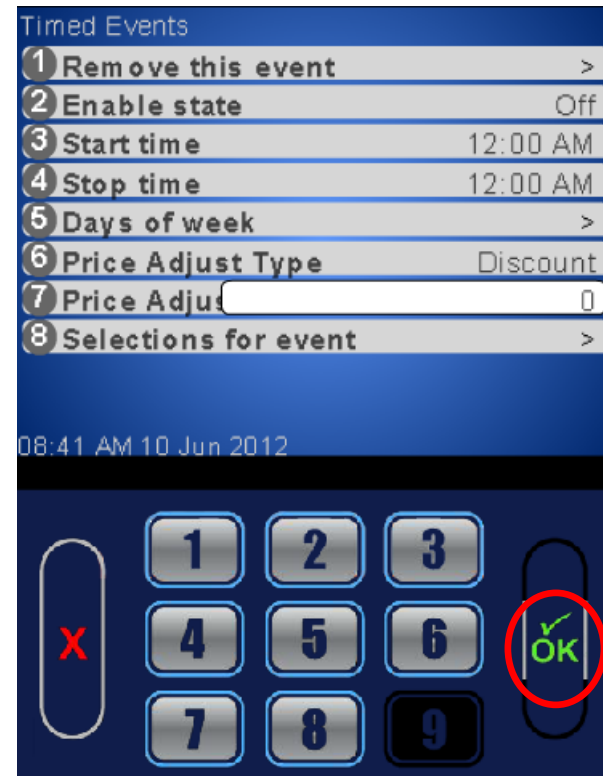



Timed Events

Adding/Removing Selections

Press the bottom of the OK button to scroll to selections. Press 2 on the keypad to choose the selections for this event.

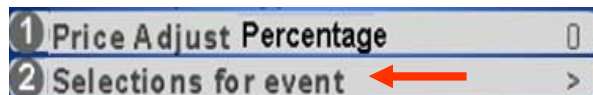

On the keypad to choose tray where selections are located that you want to add to this event or choose add all.

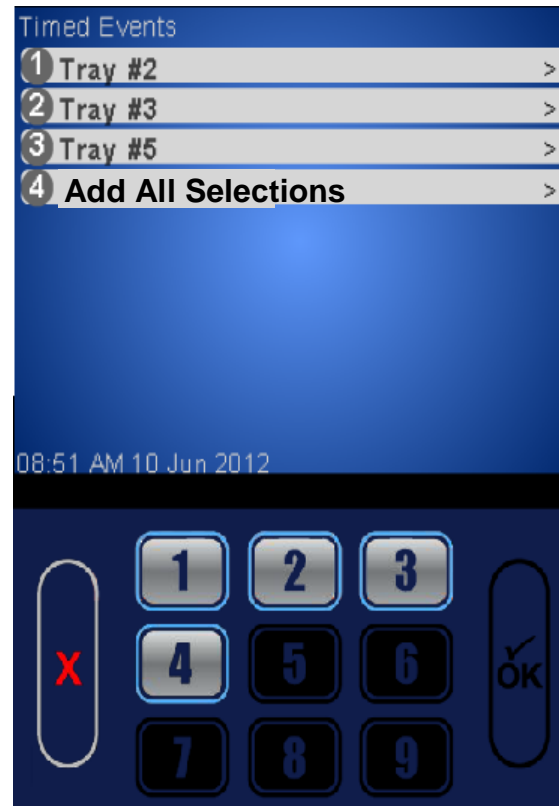

Use the keypad to add or remove a checkmark to the selections you want associated with this event.





Timed Events

Inactivity Minutes

Press 9 on the keypad to set the Inactivity Minutes. This menu item is only available for a Power Saving event.

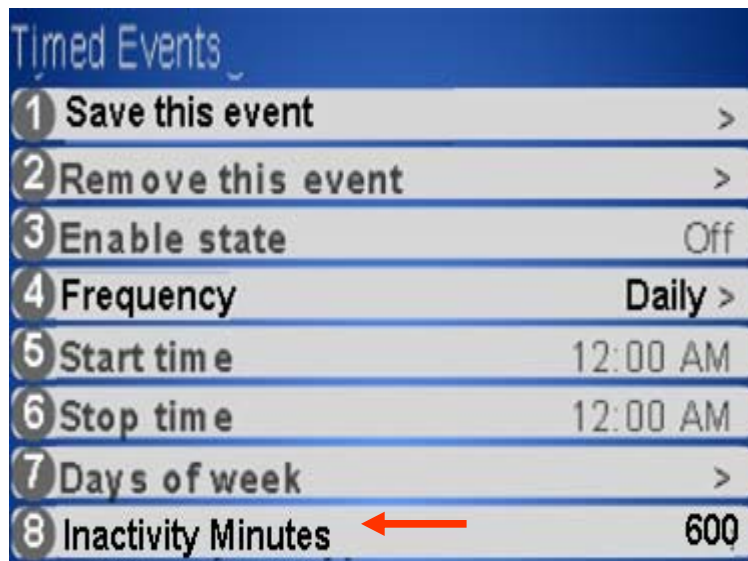

Enter from 1 to 600 the number of minutes of inactivity before the machine goes into Power Saving Mode.





Telemetry

Telemetry

The Telemetry Menu is used to set up your:

- Intergraded Wireless Radio
- Cashless
- Remote DEX Alerts
- Mesh Network.

The Telemetry Menu also allows you to send a Dex file on demand in addition to the scheduled times.

A welcome packet was sent with your machine that will provide additional information on configuring and setting up your account information for Telemetry.





Telemetry Assigning Unit

Assigning a Unit

Before assigning the unit, you must establish an account with Heartland Payment Systems and Crane Streamware. All of the information and Applications are included in the Welcome packet the came with the machine. If you have any questions, contact your Crane Sales Person.

- When the customer account is established, Crane Streamware will email the customer configuration file for uploading and assigning the Merchant Media.
- Create a folder on your USB flash drive named atlas. Copy your VixConfigData.cfg file to this folder.





Telemetry Assigning Unit

Power the machine off, remove the board cover and verify the jumper on J27 is installed on pins 2-3 to enable high power operation on USB1 (the upper two pins).

Verify the radio is connected to USB1 (top Left USB port). USB1 is the high-power USB port and the only one that will support the radio. Replace the board cover and power up the machine.

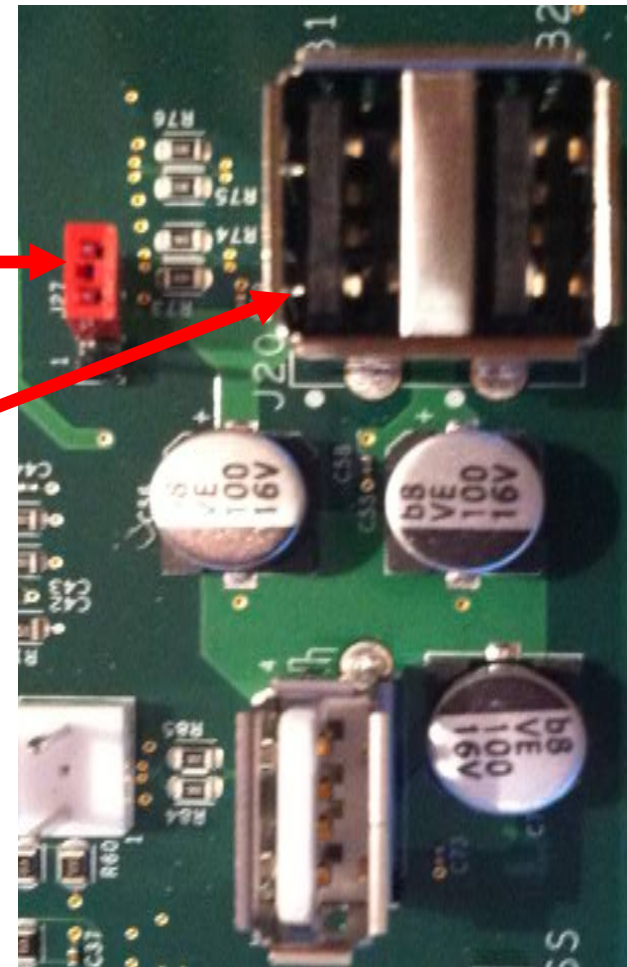



Telemetry Assigning Unit

Access the service mode by entering PIN 3333

Insert the Flash Drive with the VixConfigData.cfg file into USB 3 on the control board

Press 0 on the keypad for Telemetry

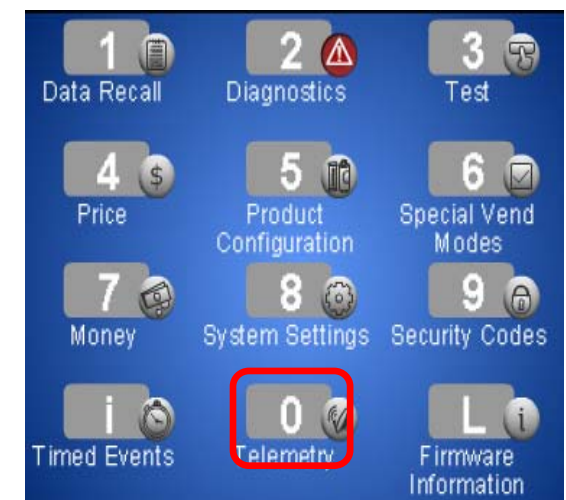
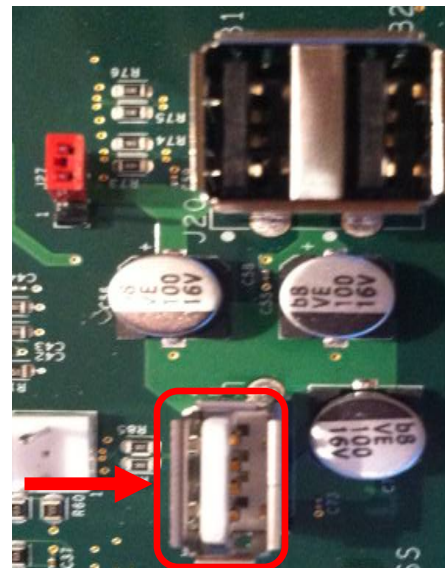



Telemetry

Assigning Unit

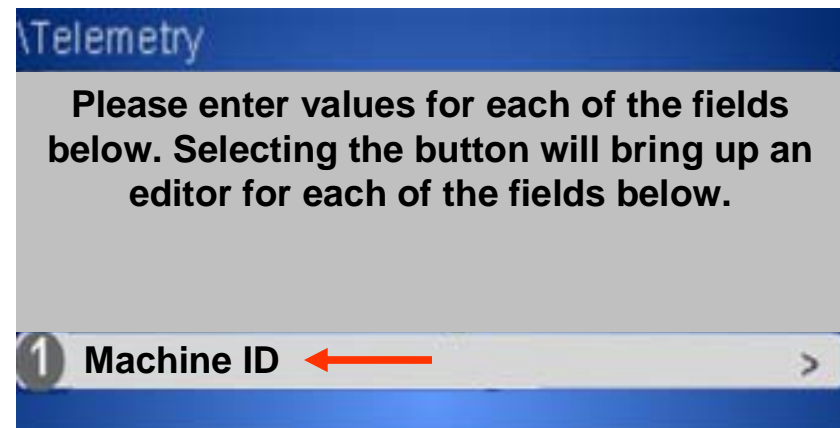
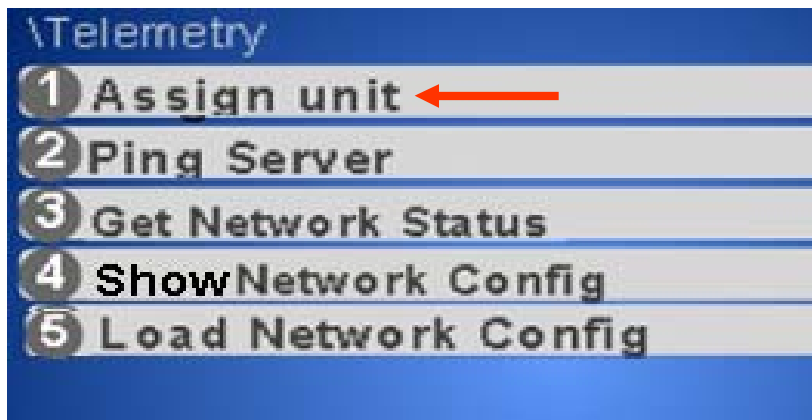

Press 1 on the keypad to Assign the Unit
The VMC will update the customer information from the flash drive. Once this is complete, the Media Merchant will reboot. This will take a few Minutes.

When the machine reboots the following screen should appear.
Press 1 to enter a Machine ID number





Telemetry Assigning Unit

- A numeric box will appear as a reference for the numbers to push on the keypad.
- As an example, if you want to enter the letter b you would press button 2 twice.
- Pressing  on the keypad will change the reference box between numbers letters and caps.
- The  is the backspace key.
- Once the message is entered press OK.

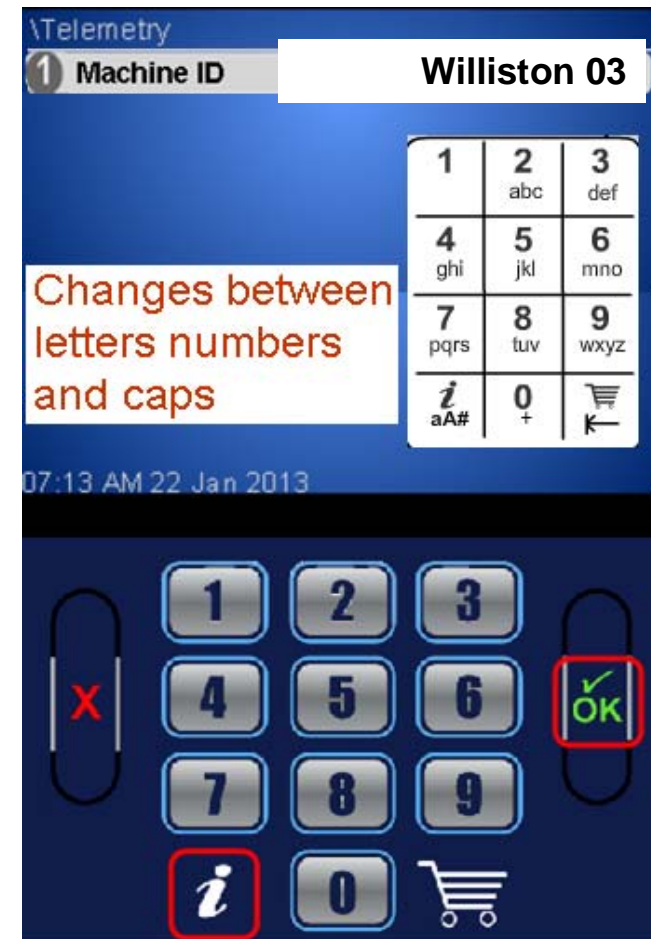



Telemetry Assigning Unit

After pressing OK the following screen should appear with the ID number in the right hand corner.
To Validate Entries press 2

The display will prompt Validating Entries followed by Finalizing Assignment.

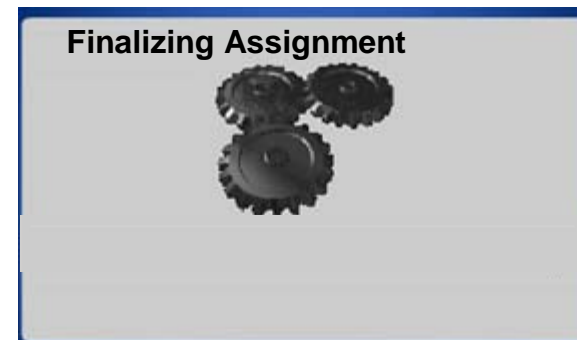
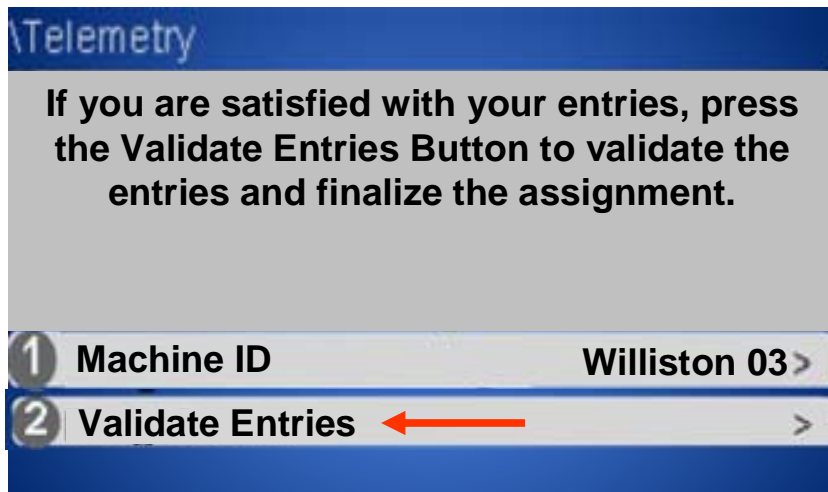



Telemetry

Assigning Unit

Press button 1 to Reboot the machine and complete the assignment process. Once the reboot process is complete remove the flash drive from the USB port and test. Button 1 in the Telemetry Menu will now become Send Dex. You will also now have a menu option to Unassign the unit. **It is important that if for any reason you change the board you Unassign the unit and assign the new board.**

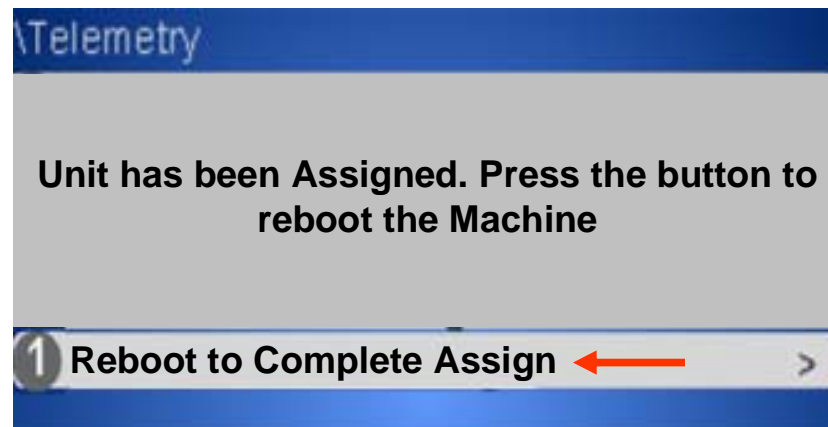



Telemetry

Send Dex

Send Dex

- Once Telemetry is assigned number 1 on the menu will change to Send Dex.
- Send Dex is also available in the route drive access menu by entering PIN 1111 and selecting Telemetry.
- Press 1 on the keypad to send a Dex file when servicing the machine.





Telemetry Ping Server

Press button 2 to
Ping the Server.



The yellow LED on
the radio should
illuminate and the
screen below will
show up until
Pinging is complete



The results Pass/Fail
will display to the right
of Ping Server





Telemetry

Get Network Status

Press button 3 to
Get the Network
Status.

The screen below
will show the current
network Status.

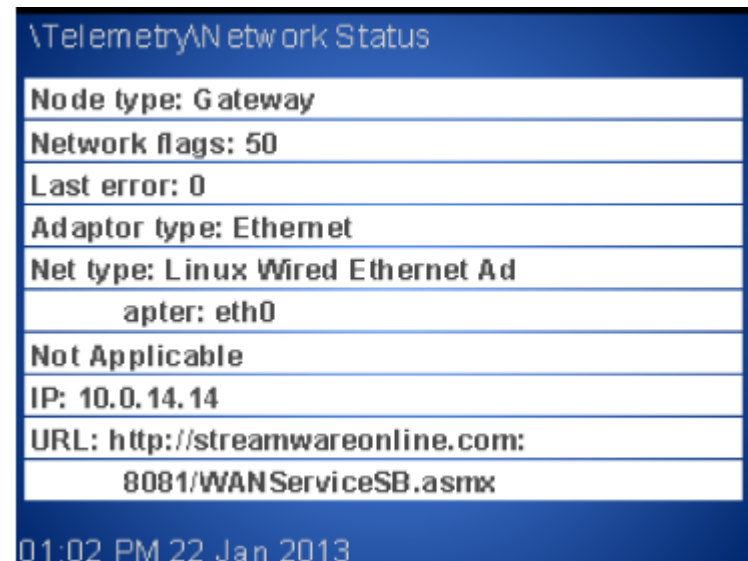



Telemetry

Get Network Status

Press button 4 to
Show Network
Configuration



Press button 5 to
Load Network
Configuration





Telemetry Enable Mesh

Mesh Networking - CCM

- Is a proprietary wireless network that CMS uses for Mesh communication.
- This network is used for Telemetry device, Client to Gateway communication.
- Mesh allows machines in a area with bad cell service to send information to a host machine with a radio, the Host machine becomes a Gateway to send the information.
- Mesh can also communicate with any machine that has Navigator installed.
- The CCM is mounted on the top left corner of the Atlas Controller.

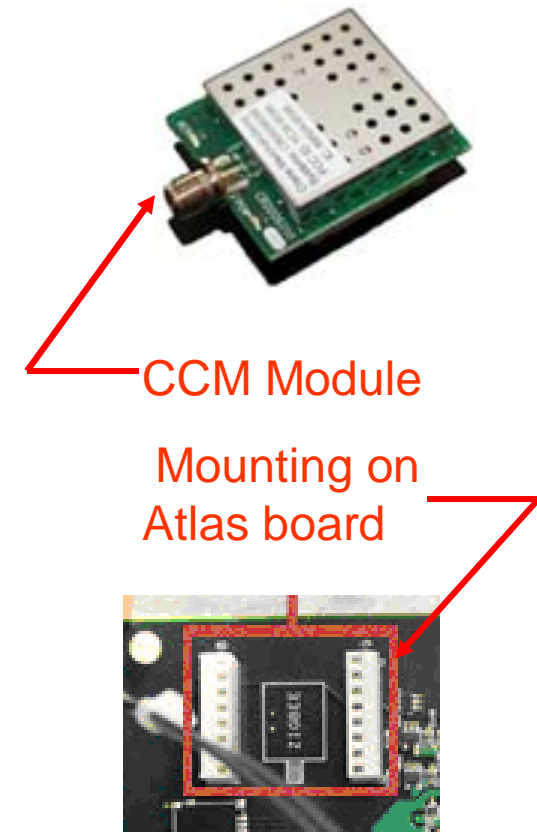

CCM Module

Mounting on
Atlas board



Telemetry Enable Mesh

Mesh Networking

- Once the CCM and radio are installed you will have an option to Enable Mesh.
- Make sure the antenna used with the Zigbee has a silver connector. Gold connectors are for the radios only.
- Choose Enable Mesh with the keypad.
- A new menu will appear allowing you to choose between Gateway and Client.
- Gateway units should always be set up first.





Telemetry Unassign Unit

Unassign Unit

- It is important that at anytime you change a control board or remove a machine from a location that you Unassign the unit. This will free up that terminal ID number to be used again.
- On the keypad select Unassign unit and a conformation box will appear.
- Once confirmed the unit will be Unassigned.

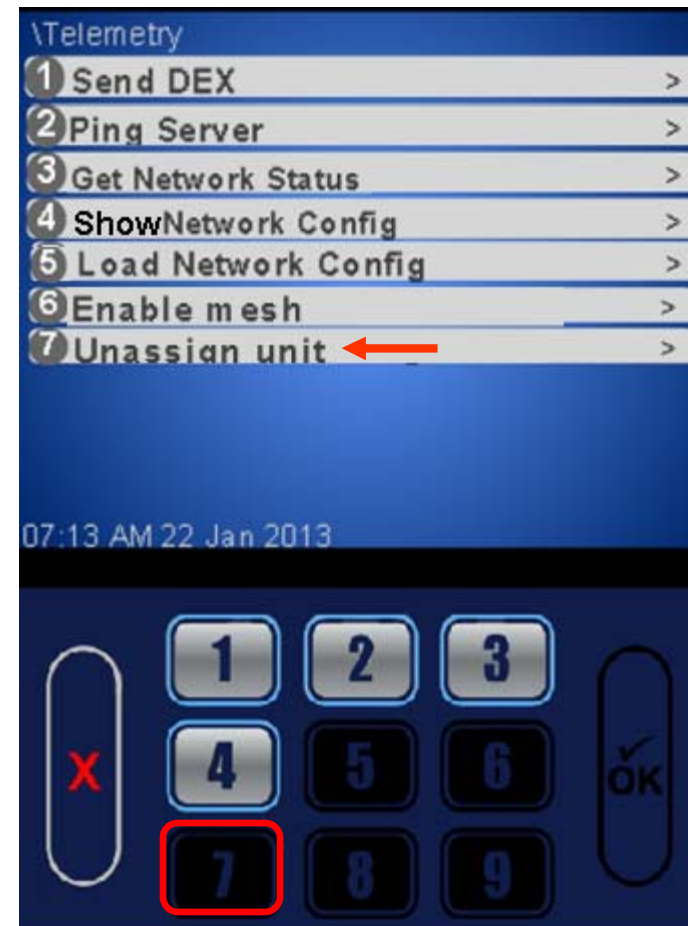



Firmware Information

Firmware Information

Choosing Firmware on the keypad brings up a information screen that shows you the following information

- All the MDB peripherals in the machine including manufacturer, serial number and software version.
- The software version of the SureVend™ board.
- The software version of the I/O board.
- The software version of the LE board.

| Firmware Information | | |
|----------------------|--------|-------|
| Bill Validator | | |
| MSM01AA-UA | CCD | 0514 |
| Card Reader | | |
| disconnected | -/- | -/- |
| Coin Mechanism | | |
| G-46.F 4000 | NRI | 4809 |
| 1 SureVend Version | | 103 |
| 2 I/O Board Version | | |
| LE Board | | |
| 100000008 | r11396 | 27_V5 |

10:04 AM 9 Jun 2012

Keypad: X, 1, 2, 3, 4, 5, 6, 7, 8, 9, OK

-
- For information on setting up the machine with Product Mapping, Nutritional information, and wireless options see additional information in the bag assembly that came with the machine.

Atlas Controller

Atlas Controller with
Merchant Keypad
Software:

Part # CR0020294

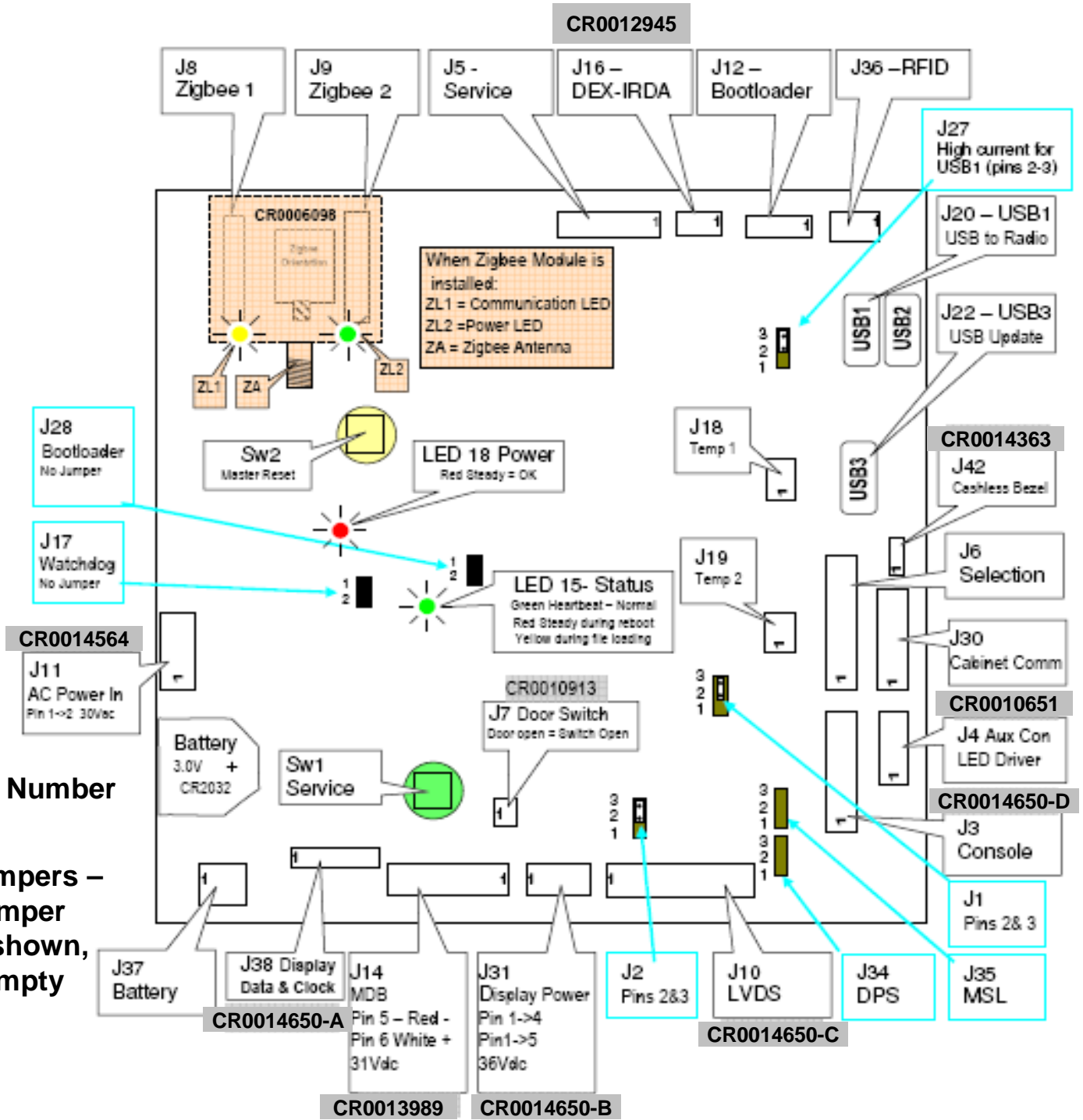

CR00XXXXX Harness Part Number

On board Jumpers –
Unless Jumper
Position is shown,
pins are empty

AC BOX ASSEMBLY CR0004739

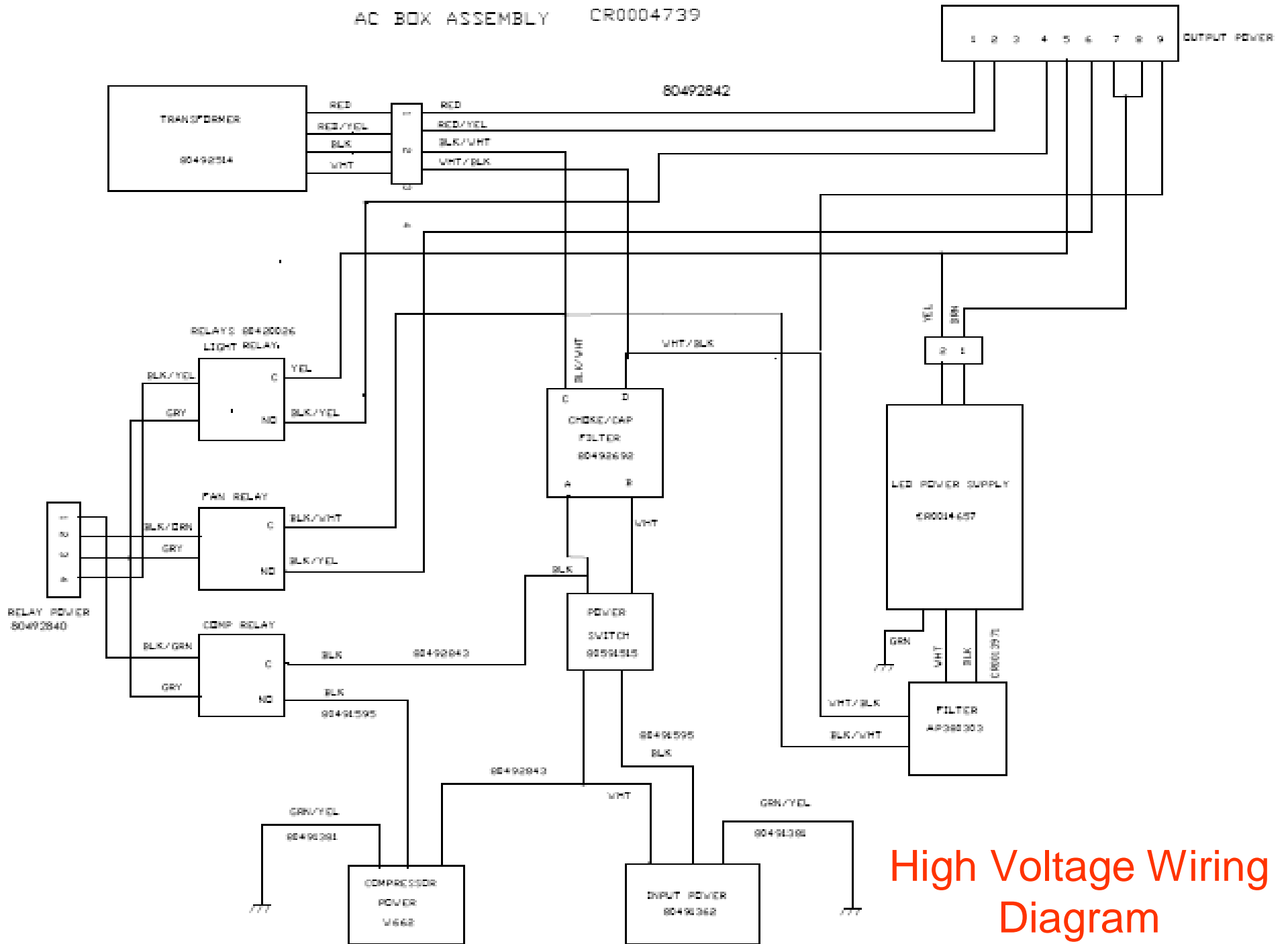

High Voltage Wiring Diagram

Software Licenses

GNU General Public License (GPL), version 2

GNU GENERAL PUBLIC LICENSE

Version 2, June 1991

Copyright (C) 1989, 1991 Free Software Foundation, Inc. 51 Franklin Street, Fifth Floor, Boston, MA 02110-1301, USA Everyone is permitted to copy and distribute verbatim copies of this license document, but changing it is not allowed. **Preamble**

The licenses for most software are designed to take away your freedom to share and change it. By contrast, the GNU General Public License is intended to guarantee your freedom to share and change free software—to make sure the software is free for all its users. This General Public License applies to most of the Free Software Foundation's software and to any other program whose authors commit to using it. (Some other Free Software Foundation software is covered by the GNU Lesser General Public License instead.) You can apply it to your programs, too.

When we speak of free software, we are referring to freedom, not price. Our General Public Licenses are designed to make sure that you have the freedom to distribute copies of free software (and charge for this service if you wish), that you receive source code or can get it if you want it, that you can change the software or use pieces of it in new free programs; and that you know you can do these things.

To protect your rights, we need to make restrictions that forbid anyone to deny you these rights or to ask you to surrender the rights. These restrictions translate to certain responsibilities for you if you distribute copies of the software, or if you modify it.

For example, if you distribute copies of such a program, whether gratis or for a fee, you must give the recipients all the rights that you have. You must make sure that they, too, receive or can get the source code. And you must show them these terms so they know their rights.

We protect your rights with two steps: (1) copyright the software, and (2) offer you this license which gives you legal permission to copy, distribute and/or modify the software.

Also, for each author's protection and ours, we want to make certain that everyone understands that there is no warranty for this free software. If the software is modified by someone else and passed on, we want its recipients to know that what they have is not the original, so that any problems introduced by others will not reflect on the original authors' reputations.

Finally, any free program is threatened constantly by software patents. We wish to avoid the danger that redistributors of a free program will individually obtain patent licenses, in effect making the program proprietary. To prevent this, we have made it clear that any patent must be licensed for everyone's free use or not licensed at all.

TERMS AND CONDITIONS FOR COPYING, DISTRIBUTION AND MODIFICATION

0. This License applies to any program or other work which contains a notice placed by the copyright holder saying it may be distributed under the terms of this General Public License. The "Program", below, refers to any such program or work, and a "work based on the Program" means either the Program or any derivative work under copyright law; that is to say, a work containing the Program or a portion of it, either verbatim or with modifications and/or translated into another language. (Hereinafter, translation is included without limitation in the term "modification".) Each licensee is addressed as "you".

Activities other than copying, distribution and modification are not covered by this License; they are outside its scope. The act of running the Program is not restricted, and the output from the Program is covered only if its contents constitute a work based on the Program (independent of having been made by running the Program). Whether that is true depends on what the Program does.

1. You may copy and distribute verbatim copies of the Program's source code as you receive it, in any medium, provided that you conspicuously and appropriately publish on each copy an appropriate copyright notice and disclaimer of warranty; keep intact all the notices that refer to this License and to the absence of any warranty; and give any true recipients of the Program a copy of this License along with the Program.

2. You may charge a fee for the physical act of transferring a copy, and you may at your option offer warranty protection in exchange for a fee.

3. You may modify your copy or copies of the Program or any portion of it, thus forming a work based on the Program, and you may distribute such modifications or work under the terms of Section 1 above, provided that you also meet all of these conditions:

a) You must cause the modified files to carry prominent notices stating that you changed the files and the date of any change.

b) You must cause any work that you distribute or publish, that in whole or in part contains or is derived from the Program or any part thereof, to be licensed as a whole at no charge to all third parties under the terms of this License.

c) If the modified program normally reads commands interactively when run, you must cause it, when started running for such interactive use in the most ordinary way, to print or display an announcement including an appropriate copyright notice and a notice that there is no warranty (or else, saying that you provide a warranty) and that users may redistribute the program under these conditions, and telling the user how to view a copy of this License. Exception: if the Program itself is interactive but does not normally print such an announcement, your work based on the Program is not required to print an announcement.)

These requirements apply to the modified work as a whole. If identifiable sections of that work are not derived from the Program, and can be reasonably considered independent and separate works in themselves, then this License, and its terms, do not apply to those sections when you distribute them as separate works. But when you distribute the same sections as part of a whole which is a work based on the Program, the distribution of the whole must be on the terms of this License, whose permissions for other licensees extend to the entire whole, and thus to each and every part regardless of what it writes.

Thus, it is not the intent of this section to claim rights or contest your rights to work written entirely by you; rather, the intent is to exercise the right to control the distribution of derivative or collective works based on the Program.

In addition, mere aggregation of another work not based on the Program (or with a work based on the Program) on a volume of a storage or distribution medium does not bring the other work under the scope of this License.

4. You may copy and distribute the Program (or a work based on it, under Section 2) in object code or executable form under the terms of Sections 1 and 2 above provided that you also do one of the following:

a) Accompany it with the complete corresponding machine-readable source code, which must be distributed under the terms of Sections 1 and 2 above on a medium customarily used for software interchange; or

b) Accompany it with a written offer, valid for at least three years, to give any third party, for a charge no more than your cost of physically performing source distribution, a complete machine-readable copy of the corresponding source code, to be distributed under the terms of Sections 1 and 2 above on a medium customarily used for software interchange; or

c) Accompany it with the information you received as to the offer to distribute corresponding source code. This alternative is allowed only for noncommercial distribution and only if you received the program in object code or executable form with such an offer, in accord with Subsection b above.)

The source code for a work means the preferred form of the work for making modifications to it. For an executable work, complete source code means all the source code for all modules it contains, plus any associated interface definition files, plus the scripts used to control compilation and installation of the executable. However, as a special exception, the source code distributed need not include anything that is normally distributed (in either source or binary form) with the major components (compiler, kernel, and so on) of the operating system on which the executable runs, unless that component itself accompanies the executable.

If distribution of executable or object code is made by offering access to copy from a designated place, then offering equivalent access to copy the source code from the same place counts as distribution of the source code, even though third parties are not compelled to copy the source along with the object code.

5. You may not copy, modify, sublicense, or distribute the Program except as expressly provided under this License. Any attempt otherwise to copy, modify, sublicense or distribute the Program is void, and will automatically terminate your rights under this License. However, parties who have received copies, or rights, from you under this License will not have their licenses terminated so long as such parties remain in full compliance.

6. You are not required to accept this License, since you have not signed it. However, nothing else grants you permission to modify or distribute the Program or its derivative works. These actions are prohibited by law if you do not accept this License. Therefore, by modifying or distributing the Program (or any work based on the Program), you indicate your acceptance of this License to do so, and all its terms and conditions for copying, distributing or modifying the Program or works based on it.

7. Each time you redistribute the Program (or any work based on the Program), the recipient automatically receives a license from the original licensor to copy, distribute or modify the Program subject to these terms and conditions. You may not impose any further restrictions on the recipients' exercise of the rights granted herein. You are not responsible for enforcing compliance by third parties to this License.

8. If, as a consequence of a court judgment or allegation of patent infringement or for any other reason (not limited to patent issues), conditions are imposed on you (whether by court order, agreement or otherwise) that contradict the conditions of this License, they do not excuse you from the conditions of this License. If you cannot distribute so as to satisfy simultaneously your obligations under this License and any other pertinent obligations, then as a consequence you may not distribute the Program at all. For example, if a patent holder would not permit royalty-free redistribution of the Program by all those who receive copies directly or indirectly through you, then the only way you could satisfy both it and this License would be to refrain entirely from distributing the Program.

If any portion of this section is held invalid or unenforceable under any particular circumstance, the balance of the section is intended to apply and the section as a whole is intended to apply in other circumstances.

It is not the purpose of this section to infringe any patents or other property right claims or to contest validity of any such claims; this section has the sole purpose of protecting the integrity of the free software distribution system, which is implemented by public license practices. Many people have made generous contributions to the wide range of software distributed through that system in reliance on consistent application of that system; it is up to the author/donor to decide if he or she is willing to distribute software through any other system and a licensee cannot impose that choice.

This section is intended to make thoroughly clear what is believed to be a consequence of the rest of this License.

9. If the distribution and/or use of the Program is restricted in certain countries either by patents or by copyrighted interfaces, the original copyright holder who places the Program under this License may add an explicit geographical distribution limitation excluding those countries, so that distribution is permitted only in or among countries not thus excluded. In such case, this License incorporates the limitation as if written in the body of this License.

10. The Free Software Foundation may publish revised and/or new versions of the General Public License from time to time. Such new versions will be similar in spirit to the present version, but may differ in detail to address new problems or concerns.

Each version is given a distinguishing version number. If the Program specifies a version number of this License which applies to it and "any later version", you have the option of following the terms and conditions either of that version or of any later version published by the Free Software Foundation. If the Program does not specify a version number of this License, you may choose any version ever published by the Free Software Foundation.

11. If you wish to incorporate parts of the Program into other free programs whose distribution conditions are different, write to the author to ask for permission. For software which is copyrighted by the Free Software Foundation, we sometimes make exceptions for this. Our decision will be guided by the two goals of preserving the free status of all derivatives of our free software and of promoting the sharing and reuse of software generally.

NO WARRANTY

12. BECAUSE THE PROGRAM IS LICENSED FREE OF CHARGE, THERE IS NO WARRANTY FOR THE PROGRAM, TO THE EXTENT PERMITTED BY APPLICABLE LAW. EXCEPT WHEN OTHERWISE STATED IN WRITING THE COPYRIGHT HOLDERS AND/OR OTHER PARTIES PROVIDE THE PROGRAM "AS IS" WITHOUT WARRANTY OF ANY KIND, EITHER EXPRESSED OR IMPLIED, INCLUDING, BUT NOT LIMITED TO, THE IMPLIED WARRANTIES OF MERCHANTABILITY AND FITNESS FOR A PARTICULAR PURPOSE. THE ENTIRE RISK AS TO THE QUALITY AND PERFORMANCE OF THE PROGRAM IS WITH YOU. SHOULD THE PROGRAM PROVE DEFECTIVE, YOU ASSUME THE COST OF ALL NECESSARY SERVICING, REPAIR OR CORRECTION.

13. IN NO EVENT UNLESS REQUIRED BY APPLICABLE LAW OR AGREED TO IN WRITING WILL ANY COPYRIGHT HOLDER, OR ANY OTHER PARTY WHO MAY MODIFY AND/OR REDISTRIBUTE THE PROGRAM AS PERMITTED ABOVE, BE LIABLE TO YOU FOR DAMAGES, INCLUDING ANY GENERAL, SPECIAL, INCIDENTAL OR CONSEQUENTIAL DAMAGES ARISING OUT OF THE USE OR INABILITY TO USE THE PROGRAM (INCLUDING BUT NOT LIMITED TO LOSS OF DATA OR DATA BEING RENDERED INACCURATE OR LOSSES SUSTAINED BY YOU OR THIRD PARTIES OR A FAILURE OF THE PROGRAM TO OPERATE WITH ANY OTHER PROGRAMS), EVEN IF SUCH HOLDER OR OTHER PARTY HAS BEEN ADVISED OF THE POSSIBILITY OF SUCH DAMAGES.

END OF TERMS AND CONDITIONS

How to Apply These Terms to Your New Programs

If you develop a new program, and you want it to be of the greatest possible use to the public, the best way to achieve this is to make it free software which everyone can redistribute and change under these terms.

To do so, attach the following notices to the program. It is safest to attach them to the start of each source file to most effectively convey the exclusion of warranty; and each file should have at least the "copyright" line and a pointer to where the full notice is found.

one line to give the program's name and an idea of what it does. Copyright (C) *yyyy* *name of author*. This program is free software; you can redistribute it and/or modify it under the terms of the GNU General Public License as published by the Free Software Foundation; either version 2 of the License, or (at your option) any later version. This program is distributed in the hope that it will be useful, but WITHOUT ANY WARRANTY; without even the implied warranty of MERCHANTABILITY or FITNESS FOR A PARTICULAR PURPOSE. See the GNU General Public License for more details. You should have received a copy of the GNU General Public License along with this program; if not, write to the Free Software Foundation, Inc., 51 Franklin Street, Fifth Floor, Boston, MA 02110-1301, USA. Also add information on how to contact you by electronic and paper mail.

If the program is interactive, make it output a short notice like this when it starts in an interactive mode:

Gnomovision version 69, Copyright (C) *year* *name of author*. Gnomovision comes with ABSOLUTELY NO WARRANTY; for details type `show w'. This is free software, and you are welcome to redistribute it under certain conditions; type `show c' for details. The hypothetical commands `show w' and `show c' should show the appropriate parts of the General Public License. Of course, the commands you use may be called something other than `show w' and `show c'; they could even be mouse-clicks or menu items—whatever suits your program.

You should also get your employer (if you work as a programmer) or your school, if any, to sign a "copyright disclaimer" for the program, if necessary. Here is a sample; alter the names:

Yooyodyne, Inc., hereby disclaims all copyright interest in the program `Gnomovision' (which makes passes at compilers) written by James Hacker, signature of Ty Coon, 1 April 1989 Ty Coon, President of Vice This General Public License does not permit incorporating your program into proprietary programs. If your program is a subroutine library, you may consider it more useful to permit linking proprietary applications with the library. If this is what you want to do, use the GNU Lesser General Public License instead of this License.

- Complete text of v2 of the GPL may be found online at <http://www.gnu.org/licenses/gpl-2.0.html>.

Software Licenses

GNU Lesser General Public License (LGPL), version 2.1

GNU LESSER GENERAL PUBLIC LICENSE

Version 2.1, February 1999

Copyright (C) 1991, 1999 Free Software Foundation, Inc. 51 Franklin Street, Fifth Floor, Boston, MA 02110-1301 USA Everyone is permitted to copy and distribute verbatim copies of this license document, but changing it is not allowed. This is the first released version of the Lesser GPL. It also counts as the successor of the GNU Library Public License, version 2, hence the version number 2.1.) **Preamble**

The licenses for most software are designed to take away your freedom to share and change it. By contrast, the GNU General Public License is intended to guarantee your freedom to share and change free software to make sure the software is free for all users.

This license, the Lesser General Public License, applies to some specially designated software packages—typically libraries—of the Free Software Foundation and other authors who decide to use it. You can use it too, but we suggest you first think carefully about whether this license or the ordinary General Public License is the better strategy to use in any particular case, based on the explanations below.

When we speak of free software, we are referring to freedom of use, not price. Our General Public Licenses are designed to make sure that you have the freedom to distribute copies of free software (and charge for this service if you wish); that you receive source code or can get it if you wish it; that you can change the software and use pieces of it in new free programs; and that you are informed that you can do these things.

To protect your rights, we need to make restrictions that forbid distributors to deny you these rights or to ask you to surrender these rights. These restrictions translate to certain responsibilities for you if you distribute copies of the library or if you modify it.

For example, if you distribute copies of the library, whether gratis or for a fee, you must give the recipients all the rights that we give you. You must make sure that they, too, receive or can get the source code. If you link other code with the library, you must provide complete object files to the recipients, so that they can relink them with the library after making changes to the library and recompiling it. And you must show them these terms so they know their rights.

We protect your rights with two different methods: (1) by copyrighting the library, and (2) by offering you the chance to copy, distribute and/or modify the library.

Finally, software patents pose a constant threat to the existence of any free program. We wish to make sure that a company cannot effectively restrict the users of a free program by obtaining a restrictive license from a patent holder. Therefore, we insist that any patent license obtained for a version of the library must be consistent with the full freedom of use specified in this license.

Most GNU software, including some libraries, is covered by the ordinary GNU General Public License. This license, the GNU Lesser General Public License, applies to certain designated libraries, and is quite different from the ordinary General Public License. We use this license for certain libraries in order to permit linking those libraries into non-free programs.

When a program is linked with a library, whether statically or using a shared library, the combination of the two is legally speaking a combined work, a derivative of the original library. The ordinary General Public License therefore permits such linking only if the entire combination fits the criteria of freedom. The Lesser General Public License permits more lax criteria for linking other code with the library.

We call this license the "Lesser" General Public License because it does less to protect the user's freedom than the ordinary General Public License. It also provides other free software developers with a more convenient means of exercising copyright and releasing their new programs. These disadvantages are the reason we use the ordinary General Public License for many libraries. However, the Lesser license provides advantages in certain special circumstances.

For example, on rare occasions, there may be a special need to encourage the widest possible use of a certain library, so that it becomes a de-facto standard. To achieve this, non-free programs may be allowed to use the library. A more frequent case is that a free library does the same job as widely used non-free libraries. In this case, there is little to be gained by limiting the free library to free software only, so we use the Lesser General Public License.

In other cases, permission to use a particular library in non-free programs enables a greater number of people to use a large body of free software. For example, permission to use the GNU C Library in non-free programs enables many more people to use the whole GNU system, as well as its variants, the GNU/Linux operating system.

The precise terms and conditions for copying, distribution and modification follow. Pay close attention to the difference between a "work based on the library" and a "work that uses the library". The former contains code derived from the library, whereas the latter must be combined with the library in order to run.

TERMS AND CONDITIONS FOR COPYING, DISTRIBUTION AND MODIFICATION

0. This License Agreement applies to any software library or other program which contains a notice placed by the copyright holder or other authorized party saying it may be distributed under the terms of this Lesser General Public License (also called "this License"). Each licensee is addressed as "you".

A "library" means a collection of software functions and/or data prepared so as to be conveniently linked with application programs (which use some of the library's functions and data) to form executables.

The "Library", below, refers to any such software library or work which has been distributed under these terms. A "work based on the Library" means either the Library or any derivative work under copyright law that is to say, a work containing the Library or a portion of it, either verbatim or with modifications and/or translated straightforwardly into another language. (Hereinafter, translation is included without limitation in the term "modification".)

"Source code" for a work means the preferred form of the work for making modifications to it. For a library, complete source code means all the source code for all modules it contains, plus any associated interface definition files, plus the scripts used to control compilation and installation of the library.

Activities other than copying, distribution and modification are not covered by this License; they are outside its scope. The act of running a program using the Library is not restricted, and output from such a program is covered only if its contents constitute a work based on the Library (independent of the use of the Library in a tool for writing it). Whether that is true depends on the nature of the Library and does not depend on the nature of the program that uses the Library's code.

1. You may copy and distribute verbatim copies of the Library's complete source code as you receive it, in any medium, provided that you conspicuously and appropriately publish on each copy an appropriate copyright notice and disclaimer of warranty; keep intact all the notices that refer to this License and to the absence of any warranty; and distribute a copy of this License along with the Library.

You may charge a fee for the physical transferring of a copy, and/or you may at your option offer warranty protection in addition to the fee.

2. You may modify your copy or copies of the Library or any portion of it, thus forming a work based on the Library, and copy and distribute such modifications or your work under the terms of Section 1 above, provided that you also meet all of these conditions:

a) The modified work must itself be a software library.

b) You must cause the files modified to carry prominent notices stating that you changed the files and the date of any change.

c) You must cause the whole of the work to be licensed at no charge to all third parties under the terms of this License.

d) If a facility in the modified Library is a function or table of data to be supplied by an application program that uses the facility, other than as an argument passed when the facility is invoked, then you must make a good faith effort to ensure that, in the event an application does not supply such function or table, the facility still operates, and performs whatever part of its purpose remains meaningful. (For example, a function in a Library to compute square roots has a purpose that is entirely well-defined independent of the application. Therefore, Subsection 2d requires that any application-supplied function or table used by this function must be optional; if the application does not supply it, the square root function must still compute square roots.)

These requirements apply to the modified work as a whole. If identifiable sections of that work are not derived from the Library, and can be reasonably considered independent and separate works in themselves, then this License, and its terms, do not apply to those sections when you distribute them as separate works. But when you distribute the same sections as part of a whole which is a work based on the Library, the distribution of the whole must be on the terms of this License, whose permissions for other licensors extend to the entire whole, and thus to each and every part regardless of who wrote it.

Thus, it is not the intent of this section to deny rights or content your rights to work written entirely by you, rather, the intent is to exercise the right to control the distribution of derivative or collective works based on the Library.

In addition, mere aggregation of another work not based on the Library with the Library (for example, in a volume of a storage or distribution medium) does not bring the other work under the scope of this License.

3. You may opt to apply the terms of the ordinary GNU General Public License instead of this License to a given copy of the Library. To do this, you must alter all the notices that refer to this License, so that they refer to the ordinary GNU General Public License, version 2, instead of to this License. (If a newer version than version 2 of the ordinary GNU General Public License has appeared, then you can specify that version instead if you wish.) Do not make any other change in these notices.

Once this change is made in a given copy, it is reversible for that copy, so the ordinary GNU General Public License applies to all subsequent copies and derivative works made from that copy.

This option is useful when you wish to copy part of the code into a program that is not a library.

4. You may copy and distribute the Library (or a portion or derivative of it, under Section 2) in object code or executable form under the terms of Sections 1 and 2 above provided that you accompany it with the complete corresponding machine-readable source code, which must be distributed under the terms of Sections 1 and 2 above on a medium customarily used for software interchange.

5. Distribution of object code is made by offering access to copy from a designated place, then offering equivalent access to copy the source code from the same place satisfies the requirement to distribute the source code, even though third parties are not compelled to copy the source along with the object code.

6. A program that contains no derivative of any portion of the Library, but is designed to work with the Library by being compiled or linked to it, is called a "work that uses the Library". Such a work, in isolation, is not a derivative work of the Library, and therefore falls outside the scope of this License.

However, linking a "work that uses the Library" with the Library creates an executable that is a derivative of the Library (because it contains portions of the Library), rather than a "work that uses the library". The executable is therefore covered by this License. Section 6 states terms for distribution of such executables.

When a "work that uses the Library" uses material from a header file that is part of the Library, the object code for the Library even though the source code is not. Whether this is true is especially significant if the work can be linked without the Library, or if the work is itself a library. The threshold for this to be true is not precisely defined by law.

7. If such an object file uses only numerical parameters, data structure layouts and accessions, and small macros and small inline functions (ten lines or less in length), then the use of the object file is unrestricted, regardless of whether it is legally a derivative work. (Executables containing this object code plus portions of the Library will still fall under Section 6.)

Otherwise, if the work is a derivative of the Library, you may distribute the object code for the work under the terms of Section 6, whether or not they are linked directly with the Library itself.

8. As an exception to the Sections above, you may also combine or link a "work that uses the Library" with the Library to produce a work containing portions of the Library, and distribute that work containing portions of the Library, provided that the terms permit modification of the work for the customer's own use and reverse engineering for debugging such modifications.

9. You must give prominent notice with each copy of the work that the Library is used in it and that the Library and its use are covered by this License. You must supply a copy of this License. If the work during execution displays copyright notices, you must include the copyright notice for the Library among them, as well as a reference directing the user to the copy of this License. Also, you must do one of these things:

a) Accompany the work with the complete corresponding machine-readable source code for the Library, including whatever changes were used in the work (which must be distributed under Sections 1 and 2 above), and if the work is an executable linked with the Library, with the complete machine-readable "work that uses the Library", as object code and/or source code, so that the user can modify the Library and then relink to produce a modified executable containing the modified Library. (It is understood that the user who changes the contents of definitions files in the work will not necessarily be able to recompile the application to use the modified definitions.)

b) Use a suitable shared library mechanism for linking with the Library, a suitable mechanism is one that (1) uses at all an intermediate copy, rather than copying Library functions into the executable, and (2) will operate properly with a modified version of the Library, if the user installs one, as long as the modified version is interface-compatible with the version that the work was made with.

c) Accompany the work with a written offer, valid for at least three years, to give the same user the materials specified in Subsection 6b, above, for a charge no more than the cost of performing the distribution.

d) Distribution of the work is made by offering access to copy from a designated place, offer equivalent access to copy the above specified materials from the same place.

e) Verify that the user has already received a copy of these materials or to give the user a copy.

For an executable, the required form of the "work that uses the Library" must include any data and utility programs needed for reproducing the executable from it. However, as a special exception, the materials to be distributed need not include anything that is normally distributed (in either source or binary form) with the major components (compiler, kernel, and so on) of the operating system on which the executable runs, unless that component itself accompanies the executable.

It may happen that the requirement contradicts the license restrictions of other proprietary libraries that do not normally accompany the operating system. Such a contradiction means you cannot use both them and the Library together in an executable that you distribute.

7. You may place library facilities that are a work based on the Library side-by-side in a single library together with other library facilities not covered by the License, and distribute such a combined library, provided that the separate distribution of the work based on the Library and of the other library facilities is otherwise permitted, and provided that you do these two things:

a) Accompany the combined library with a copy of the same work based on the Library, uncombined with any other library facilities. This must be distributed under the terms of the Sections above.

b) Give prominent notice with the combined library of the fact that part of it is a work based on the Library, and explaining where to find the accompanying uncombined form of the same work.

8. You may not copy, modify, sublicense, link with, or distribute the Library except as expressly provided under this License. Any attempt otherwise to copy, modify, sublicense, link with, or distribute the Library is void, and will automatically terminate your rights under this License. However, parties who have received copies, or rights, from you under this License will not have their licenses terminated so long as such parties remain in full compliance.

9. You are not required to accept this License, since you have not agreed to it. However, nothing else grants you permission to modify or distribute the Library or its derivative works. These actions are prohibited by law if you do not accept this License. Therefore, by modifying or distributing the Library (or any work based on the Library), you indicate your acceptance of this License to do so, and all its terms and conditions for copying, distributing or modifying the Library or works based on it.

10. Each time you redistribute the Library (or any work based on the Library), the recipient automatically receives a license from the original licensor to copy, distribute, link with or modify the Library subject to these terms and conditions. You may not impose any further restrictions on the recipients' exercise of the rights granted herein. You are not responsible for enforcing compliance by third parties with this License.

11. It is, as a consequence of a court judgment or arbitration proceeding (not limited to patent suits), conditions are imposed on you (whether by court order, agreement or otherwise) that contradict the conditions of this License, you do not excuse you from the conditions of this License. If you cannot distribute so as to satisfy simultaneously your obligations under this License and any other pertinent obligations, then as a consequence you may not distribute the Library at all. For example, if a patent license would not permit royalty-free redistribution of the Library by all those who receive copies, directly or indirectly through you, then the only way you could satisfy both it and this License would be to refrain entirely from distribution of the Library.

If any portion of this section is held invalid under any particular circumstance, the balance of the section is intended to apply, and the section as a whole is intended to apply in other circumstances.

It is not the purpose of this section to induce you to infringe any patents or other property rights or to contest validity of any such claims; this section has the sole purpose of protecting the integrity of the free software distribution system which is implemented by public license practices. Many people have made generous contributions to the wide range of software distributed through that system in reliance on consistent application of that system; it is up to the authorizer to decide if he or she is willing to distribute software through any other system and a licensee cannot impose that choice.

This section is intended to make thoroughly clear what is contemplated by the rest of this License.

12. If the distribution and/or use of the Library is restricted in certain countries, either by patents or by copyrighted interfaces, the original copyright holder who places the Library into this License may add an explicit geographical distribution limitation excluding those countries, so that distribution is permitted only in or among countries not so excluded. In such case, this License incorporates the limitation as if written in the body of this License.

13. The Free Software Foundation General Public License from time to time. Such notice or notices should be included in all copies of the License. If you do not accept this License, you must still comply with all the terms and conditions of the license you have received. If you do not accept this License, you must still comply with all the terms and conditions of the license you have received. If you do not accept this License, you must still comply with all the terms and conditions of the license you have received.

Each version is given a distinguishing version number. If the Library specifies a version number of this License which applies to a later "any later version", you have the option of following the terms and conditions either of that version or of any later version published by the Free Software Foundation. If the Library does not specify a license version number, you may choose any version ever published by the Free Software Foundation.

14. You may not incorporate parts of the Library into other free programs whose distribution conditions are incompatible with these, written to the author to ask for permission. For software which is copyrighted by the Free Software Foundation, you must request permission to the Free Software Foundation; we sometimes make exceptions for this. Our decision will be guided by the two goals of preserving the free status of all derivatives of our free software and of promoting the sharing and reuse of software generally.

NO WARRANTY

15. BECAUSE THE LIBRARY IS LICENSED FREE OF CHARGE, THERE IS NO WARRANTY FOR THE LIBRARY, TO THE EXTENT PERMITTED BY APPLICABLE LAW EXCEPT WHEN OTHERWISE STATED IN WRITING THE COPYRIGHT HOLDERS AND/OR OTHER PARTIES PROVIDE THE LIBRARY "AS IS" WITHOUT WARRANTY OF ANY KIND, EITHER EXPRESSED OR IMPLIED, INCLUDING, BUT NOT LIMITED TO, THE IMPLIED WARRANTIES OF MERCHANTABILITY AND FITNESS FOR A PARTICULAR PURPOSE. THE ENTIRE RISK AS TO THE QUALITY AND PERFORMANCE OF THE LIBRARY IS WITH YOU. SHOULD THE LIBRARY PROVE DEFECTIVE, YOU ASSUME THE COST OF ALL NECESSARY SERVICING, REPAIR OR CORRECTION.

16. IN NO EVENT UNLESS REQUIRED BY APPLICABLE LAW OR AGREED TO IN WRITING WILL ANY COPYRIGHT HOLDER, OR ANY OTHER PARTY WHO MAY MODIFY AND/OR REDISTRIBUTE THE LIBRARY AS PERMITTED ABOVE, BE LIABLE TO YOU FOR DAMAGES, INCLUDING ANY GENERAL, SPECIAL, INCIDENTAL OR CONSEQUENTIAL DAMAGES ARISING OUT OF THE USE OR INABILITY TO USE THE LIBRARY (INCLUDING BUT NOT LIMITED TO LOSS OF DATA OR BEING RENDERED INACCURATE OR LOSSES SUSTAINED BY YOU OR THIRD PARTIES OR A FAILURE OF THE LIBRARY TO OPERATE WITH ANY OTHER SOFTWARE), EVEN IF SUCH HOLDER OR OTHER PARTY HAS BEEN ADVISED OF THE POSSIBILITY OF SUCH DAMAGES.

END OF TERMS AND CONDITIONS

How to Apply These Terms to Your Libraries

If you develop a new library, and you want it to be of the greatest possible use to the public, we recommend making it free software that everyone can redistribute and change. You can do so by permitting redistribution under these terms (or, alternatively, under the terms of the ordinary General Public License).

To apply these terms, attach the following notices to the library. It is safest to attach them to the start of each source file to most effectively convey the intention of warranty, and you can do so by putting the "copyright" line and a pointer to where the full notice is found.

one line to give the library's name; Copyright (C) year(s) of author This library is free software; you can redistribute it and/or modify it under the terms of the GNU Lesser General Public License as published by the Free Software Foundation; version 2.1 of the License, or (at your option) any later version. This library is distributed in the hope that it will be useful, but WITHOUT ANY WARRANTY; without even the implied warranty of MERCHANTABILITY or FITNESS FOR A PARTICULAR PURPOSE. See the GNU Lesser General Public License for more details. You should have received a copy of the GNU Lesser General Public License along with this library; if not, write to the Free Software Foundation, Inc., 51 Franklin Street, Fifth Floor, Boston, MA 02110-1301 USA Also add information on how to contact you by electronic and paper mail.

You should also get your library's name, year of copyright information, and your name, title, and address into a "copyright" notice in the library, if necessary. Here is a sample for the names: Yoyodyne, Inc., hereby disclaims all copyright in the library 'Frob' (a library for tweaking knobs) written by James Randi: signature of Ty Coon, 1 April 1999 Ty Coon, President of Vice This is all there is to it!

- Complete text of v2.1 of the LGPL may be found online at <http://www.gnu.org/licenses/lgpl-2.1.html>.