



SENTINEL

FREE STANDING DIRECT VENT GAS STOVE

 marquis
COLLECTION

Unit Illustrated: FDV350N Direct Vent Natural Gas Stove, F35DB Black Door and Ceramic Glass, LOGF35 Fibre Oak Log Set with Embers.

Direct Vent Free Standing Stove; a safe and efficient heating appliance with the convenience of gas. Your best choice for installation anywhere throughout your home.

DIMENSIONS AND SIZING

With a direct vent appliance you can vent either through the side wall above the unit or straight up through the roof.

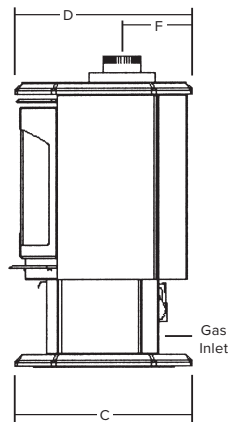
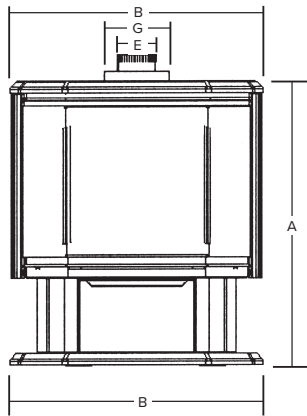

FDV350

- A 30 3/8"
- B 27 5/16"
- C 19 1/16"
- D 19 1/16"
- E 4" dia.
- F 7 1/2"
- G 7" dia.

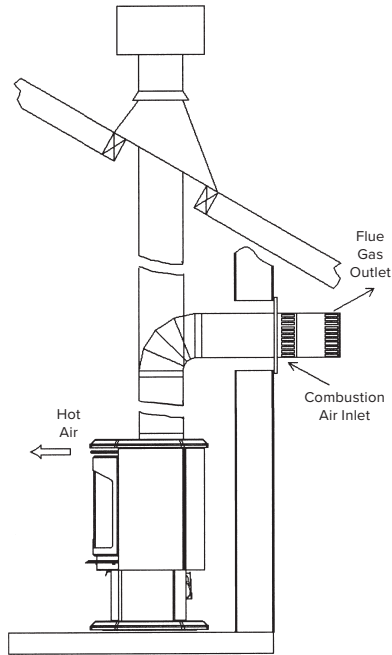

STANDARD FEATURES

- Millivolt Valve with Hi-Low heat and flame adjustment and allows operation during a power failure
- Proflame II (PF2) Models include Remote Control – Features flame, fan, thermostat, smart thermostat and battery backup
- Dual burner system, with realistic flame pattern
- Heat radiating ceramic glass with panoramic view from three sides
- Mobile home approved
- Approved for installation in a bedroom or bed sitting room
- Black Louver
- Fibre Oak Log Set with Embers*

OPTIONAL FEATURES

Fan Kit: Heat activated with variable speed control

Brick Refractory Liner

Thermostat: Wall Mount Millivolt Thermostat or Programmable Thermostat

Remote Control (Millivolt): On/Off, Thermostat On/Off, Thermostat On/Off modulating, Thermostat On/Off modulating

B-Vent Adapter (Convert Stove to 4" B-Vent)

MINIMUM CLEARANCES TO COMBUSTIBLES

- 12" from side of unit
- 3" from back of unit
- 3" from side of unit in corner

ALCOVE INSTALLATION

- 30" depth (max.)
- 55 1/2" height (min.)
- 52 1/2" width (min.)

Model	FDV350N / FDV350NE2	FDV350LP / FDV350LPE2
Fuel	Natural	Propane
Input Max	37,000 BTU	35,000 BTU
Input Min.	29,000 BTU	27,000 BTU
FE (P.4.1-15)	66.63% / 67.47%	69.33% / 70.17%

LOG SET



LOGF35
Fibre Oak with Embers

SAFETY SCREEN BARRIER



REMOTE CONTROLS



Marquis Fireplaces maintains a program of continuous testing, refinement and improvements of all its products. Some aspect of units shown here may be changed at any time without notice or obligation.

Certified for USA and Canada to: ANSI Z21.88-2017 / CSA 2.33-2017, CSA 2.17-2017

Note: Components may have to be ordered separately to create a complete unit. Discuss with your local Marquis Dealer for clarification.

Crafted entirely in Canada, each Marquis fireplace is built to the highest standards and made to last.



2340 Logan Avenue
Winnipeg, Manitoba, CAN
R2R 2V3
Phone: 204.632.1962
Fax: 204.632.1960
marquisfireplaces.net

LIMITED LIFETIME WARRANTY

Printed in Canada
B070 – 07/18