

**TOWN OF ROXBURY  
REGULATIONS GOVERNING  
SUBDIVISION AND SITE PLAN  
REVIEW**

ADOPTED BY THE PLANNING BOARD ON JUNE 14, 2022  
AFTER PUBLIC HEARING ON JUNE 14, 2022

# TABLE OF CONTENTS

SECTION I.	AUTHORITY AND PURPOSE . . . . .	SUB 1
SECTION II.	PURPOSE AND APPLICABILITY . . . . .	SUB 1
SECTION III.	DEFINITIONS . . . . .	SUB 1
SECTION IV.	GENERAL REQUIREMENTS FOR THE SUBDIVISION OF LAND . . . . .	SUB 3
SECTION V.	SUBDIVISION REVIEW PROCEDURES . . . . .	SUB 3
	A. Preliminary Conceptual Consultation . . . . .	Sub 3
	B. Design Review Phase . . . . .	Sub 4
	C. Submission of Completed Application . . . . .	Sub 4
	D. Board Action on Completed Application . . . . .	Sub 4
	E. Failure of the Planning Board to Act . . . . .	Sub 5
	F. Conditional Approval . . . . .	Sub 5
	G. Expedited Review . . . . .	Sub 5
	H. Public Hearing . . . . .	Sub 6
	I. Notification . . . . .	Sub 6
	J. Fees . . . . .	Sub 6
	K. Site Inspections . . . . .	Sub 7
	L. Concurrent and Joint Hearings , , , . . . . .	Sub 7
SECTION VI.	SUBMISSION REQUIREMENTS . . . . .	SUB 7
SECTION VII.	SUBDIVISION DESIGN STANDARDS . . . . .	SUB 10
SECTION VIII.	DEVELOPMENTS HAVING REGIONAL IMPACT . . . . .	SUB 12
SECTION IX.	PREVIOUSLY-APPROVED SUBDIVISIONS . . . . .	SUB 13
SECTION X.	SPECIAL FLOOD HAZARD AREAS . . . . .	SUB 13
SECTION XI.	PERFORMANCE GUARANTEE . . . . .	SUB 13
SECTION XII.	REVOCATION OF PLANNING BOARD APPROVAL . . . . .	SUB 14
SECTION XIII.	ADMINISTRATION AND ENFORCEMENT . . . . .	SUB 14
SECTION XIV.	APPEALS . . . . .	SUB 14
SECTION XV.	VALIDITY . . . . .	SUB 14
SECTION XVI.	AMENDMENTS . . . . .	SUB 14
SECTION XVII.	EFFECTIVE DATE . . . . .	SUB 15
SECTION XVIII.	CHECKLIST FOR LOT LINE ADJUSTMENT OR TECHNICAL SUBDIVISION . . . . .	SUB 16
SECTION XIX.	SUBDIVISION CHECKLIST. . . . .	SUB 17

## APPENDICES :

- A. ROAD & DRIVEWAY DESIGN AND CONSTRUCTION STANDARDS
- B. REQUIREMENTS FOR SOILS AND WETLANDS DATA
- C. SAMPLE FORMS FOR PUBLIC NOTIFICATION
- D. CRITERIA FOR DETERMINING REGIONAL IMPACT
- E. PROCEDURAL FLOWCHART FOR APPLICATION REVIEW

# REGULATIONS GOVERNING THE SUBDIVISION OF LAND

## SECTION I. AUTHORITY

Pursuant to the authority vested in the Roxbury Planning Board by the voters of the Town of Roxbury, and in accordance with the provisions of RSA 674:35 of the New Hampshire Revised Statutes Annotated, and as amended, the Roxbury Planning Board adopts the following regulations governing the subdivision of land in the Town of Roxbury, New Hampshire, hereinafter known as the Roxbury Subdivision Regulations.

## SECTION II. PURPOSE AND APPLICABILITY

The purpose of these regulations is to provide for the orderly present and future development of the Town by promoting and preserving the public health, safety, convenience and welfare of its residents.

These regulations apply to Planning Board review and approval or disapproval of all subdivisions as defined by RSA 672:14 and minor lot line adjustments or boundary agreements. They do not apply to voluntary mergers as defined by RSA 674:39-a.

## SECTION III. DEFINITIONS

- A. **Abutter:** Means: (1) any person whose property is located in New Hampshire and adjoins or is directly across the street or stream from the land under consideration by the local land use board; and (2) affected municipalities and the regional planning commission(s) in the event of developments having regional impact. For purposes of receiving testimony only, and not for purpose of notification, the term "abutter" shall include any person who is able to demonstrate that his land will be directly affected by the proposal under consideration. For purposes of receipt of notification by a municipality of a local land use board hearing, in the case of an abutting property being under a condominium or other collective form of ownership, the term abutter means the officers of the collective or association, as defined in RSA356-B: 3, XXIII.
- B. **Applicant:** Means the owner of record of the land to be subdivided, or his\her designated agent.
- C. **Application, Complete:** Means a final plat and all accompanying materials and fees as required by these regulations.
- D. **Approval:** Means recognition by the Planning Board, certified by written endorsement on the plat, that the plat meets the requirements of these Regulations and in the judgment of the Board satisfies all criteria of good planning and design.
- E. **Approval, Conditional:** Means recognition by the Planning Board, certified by written endorsement on the plat, that the plat is not finally approved

nor ready for filing with the Registry of Deeds until such time as certain conditions, set forth by the Board, are met. This is not to be confused with a plat that has been approved *subject to certain conditions* that would be met as part of the implementation of the plan.

- F. **Board:** Means the Planning Board of the Town of Roxbury.
- G. **Development:** Means any construction or grading activities on real estate for other than agricultural and silvicultural (tree care and harvesting) practices.
- H. **Easement:** Means the authorization by a property owner for the use by another, and for a specific purpose, of any designated part of his/her property.
- I. **Frontage:** Means that side of a lot abutting a street or body of water and ordinarily regarded as the front of the lot.
- J. **Lot:** Means a parcel of land capable of being occupied that is of sufficient size to meet the minimum requirements for use, building coverage, and area.
- K. **Lot of Record:** Means a parcel, the plat or description of which has been recorded at the county register of deeds.
- L. **Lot Line Adjustment:** Means adjustments to the boundary between adjoining properties, where no new lots are created.
- M. **Plat:** Means the map, drawing or chart on which the plan of subdivision is presented to the Board for approval, and which, if approved, will be submitted to the County Register of Deeds for recording.
- N. **Public Hearing:** Means a meeting, notice of which must be given per RSA 675:7 and 676:4,I (d), at which the public is allowed to offer testimony.
- O. **Public Meeting:** Means the regular business meeting of the Planning Board as required per RSA 673:10. Notice must be posted at least 24 hours in advance and the meeting must be open to the public, although participation by the public is at the discretion of the Board.
- P. **Right-of-Way:** Means a strip of land for which legal right of passage has been granted by the landowner to provide access to a lot which lacks adequate frontage.
- Q. **Setback:** The distance between a building or structure and the nearest property line, wetland, or sewage disposal system.
- R. **Sewage Disposal System (Individual):** Means any on-site sewage disposal or treatment system that receives either sewage or other wastes, or both. For the purposes of this regulation, this means all components of the system, including the leach field.
- S. **Street:** Means a publicly approved road maintained for vehicular travel, or a road that appears on a subdivision plat approved by the Planning Board.
- T. **Subdivision:** Means the division of a lot, tract, or parcel of land into two (2) or more lots, plats, sites, or other divisions of land for the purpose, whether immediate or future, of sale, rent, lease, condominium

conveyance or building development. The division of a parcel of land held in common and subsequently divided into parts among several owners shall be deemed a subdivision.

- U. **Subdivision, Major:** Means any subdivision not classified as a technical subdivision.
- V. **Subdivision, Technical:** Means a subdivision of land into two lots or sites for the purpose of conveying one such lot or site directly to an abutting landowner. The parcel to be conveyed does not constitute a separate building lot; however, said parcel may be used for building development in conjunction with contiguous land owned by the abutter.

#### SECTION IV. GENERAL REQUIREMENTS FOR SUBDIVISION OF LAND

- A. **Character of Land for Subdivision:** Land of such character that it cannot, in the judgment of the Board, be safely used for building development purposes because of exceptional danger to health or peril from fire, flood, poor drainage, excessive slope, or other hazardous conditions, shall not be platted for residential, commercial, or industrial subdivision, nor for such other uses as may increase danger to life or property, or aggravate the flood hazard.
- B. **Premature Subdivision:** The Board may provide against such scattered or premature subdivision of land as would involve danger or injury to health, safety, or prosperity by reason of the lack of water supply, sewage disposal, drainage, transportation, schools, fire protection, or other public services which necessitate the excessive expenditure of public funds for the supply of such services.
- C. **Preservation of Existing Features:** Wherever feasible, suitable steps shall be taken to preserve and protect significant existing features such as trees, scenic points, stone walls, rock outcroppings, water bodies, and historic landmarks. Where possible, the boundary line(s) should follow stone walls.

#### SECTION V. SUBDIVISION REVIEW PROCEDURES

##### A. **Preliminary Conceptual Consultation**

- 1) The applicant may request a meeting with the Board to discuss a proposal in conceptual form and in general terms. Although this phase is strictly optional, the Board strongly suggests that the applicant avail him/herself of the opportunity to resolve any issues at this early stage that might become a problem later on. Such preapplication consultations shall be informal and directed toward:
  - a) *Reviewing the basic concepts of the proposal.*
  - b) *Reviewing the proposal with regard to the master plan and zoning ordinance.*
  - c) *Explaining the state and local regulations that may apply to the proposal.*
  - d) *Determination of the proposal as a major or technical subdivision, and of the submission items that would be required.*

- 2) Preliminary conceptual consultation shall not bind the Applicant or the Board. Such discussion may occur without formal public notice, but must occur only at a posted meeting of the Board.

**B. Design Review Phase**

- 1) Prior to submission of an application for Board action, an applicant may request to meet with the Board or its designee for non-binding discussions beyond the conceptual and general stage, involving more specific design and engineering details of the potential application.
- 2) The design review phase may proceed only after proper notification, as set forth in Paragraph I.
- 3) Statements made by Board members shall not be the basis for disqualifying said members or invalidating any action eventually taken on the application.
- 4) A rough sketch of the site should be provided, showing:
  - a) location of lot lines;
  - b) lot measurements; and
  - c) the streets surrounding the site.

**C. Submission of Completed Application**

- 1) A completed application shall be filed with the Planning Board only at its regular monthly meeting. A completed application shall consist of all data required in Section VI of these regulations.
- 2) At the next meeting for which notice can be posted - or 30 days from the date of delivery - the Board will determine whether the application is complete. If the application is incomplete, the applicant will need to resubmit under a new notification procedure.
- 3) Acceptance of an application shall only occur at a meeting of the Planning Board after due notification has been given according to Paragraph I. Acceptance will be by affirmative vote of a majority of the Board members present.
- 4) Once an application has been accepted as complete by the Board, the **65-day review** period begins.

**D. Board Action on Completed Application**

- 1) The Board shall begin consideration of the Completed Application upon acceptance. The Board shall act to approve, conditionally approve, or disapprove the Completed Application within **65 days** of acceptance.
- 2) The Board may apply to the Selectmen for an extension not to exceed an additional 90 days before acting to approve, conditionally approve or disapprove an application. An applicant may waive the requirement for Board action within the time periods specified in these regulations and consent to such extension as may be mutually agreeable.
- 3) Approval of the application shall be certified by written endorsement on the Plat and signed and dated by the Chairman of

the Board. If any application is disapproved, the grounds for such disapproval shall be adequately stated in the records of the Planning Board and in written notice given to the Applicant within 144 hours of the decision.

- 4) An approved plan shall be recorded by the Planning Board with the County Register of Deeds within 90 days of approval. Any subdivision plan not filed within this timeframe shall be considered void.

**E. Failure of the Planning Board to Act**

- 1) In the event that the Planning Board does not act on an accepted application within the prescribed time period, the applicant may petition the Selectmen to issue an order directing the Planning Board to act within 30 days.
- 2) If the Planning Board fails to act within 40 days of receiving this directive from the Selectmen, the Selectmen must approve the application unless they find in writing that the plan does not comply with a local regulation. In the event the Selectmen fail to act, the applicant may petition superior court to approve the plan.

**F. Conditional Approval**

The Board may grant conditional approval of an application, but the plat will not be signed or recorded until all of the conditions have been met. If the applicant has not complied with the conditions of approval within one (1) year, the approval is considered null and void and the applicant must submit a new subdivision application. A further public hearing is not required when such conditions:

- 1) *are administrative in nature;*
- 2) *involve no discretionary judgment on the part of the Board;*
- 3) *involve the applicant's possession of permits and approvals granted by other boards or agencies, such as the Department of Transportation, the Wetlands Board, or Water Supply and Pollution Control Division; however, any subsequent change to the plan required by such approvals would constitute grounds for a new application process.*

**G. Expedited Review**

- 1) The Planning Board may allow for an expedited review of applications for lot line adjustments, or technical subdivisions, as defined in Section III of these regulations.
- 2) The application may be submitted, accepted as complete and voted on at the same meeting, provided the public notice so indicates.
- 3) The Board may waive certain plat requirements for lot line adjustments and technical subdivisions.

**H. Public Hearing**

Prior to the approval of an application, a public hearing shall be held. Public hearings may be waived for lot line adjustments; technical



subdivisions do not require a public hearing unless requested by either the Planning Board, the applicant or any abutters, except that public notice shall be given prior to approval of the application.

**I. Notification**

- 1) Notice of a Design Review, submission of an application, or a Public Hearing shall be given by the Board to the abutters, the applicant, holders of conservation, preservation or agricultural preservation restriction, and every engineer, architect, land surveyor or soil scientist whose professional seal appears on any plat.
- 2) Notice shall be by certified mail, mailed at least ten (10) days prior to the submission. The public will be given notice at the same time, by posting at the Roxbury Town Hall and the Four Corners bulletin board, and publication in the Keene Sentinel.
- 3) The notice shall give the date, time, and place of the Planning Board meeting at which the application will be formally submitted to the Board, shall include a general description of the proposal which is to be considered, and shall identify the applicant and the location of the proposal.
- 4) If the notice for the public hearing was included in the notice of submission or any prior notice, additional notice of the public hearing is not required. Additional notice is not required of an adjourned session of a hearing provided that the date, time, and place of the adjourned session was made known at the prior meeting.

**J. Fees**

- 1) The applicant shall be responsible for all fees incurred by the processing of applications. Failure to pay such costs shall constitute valid grounds for the Board to not accept the application as complete.
- 2) Upon formal submission of the application, the cost for:
  - a) the application fee of \$100 per lot, and an administrative fee of \$200;
  - b) certified mailings and newspaper notification.
- 3) Upon approval of the application, the costs for:
  - a) making changes to the Town's tax maps;
  - b) recording the mylar with the Register of Deeds.
- 4) It shall be the responsibility of the applicant to pay reasonable fees for special investigative studies, environmental assessments, legal review of documents, administrative expenses and other matters which may be required to make an informed decision on a particular application.

**K. Site Inspections**

- 1) Whenever the Board deems it necessary for the consideration of an

application to visit the site, the Board shall arrange a time that is reasonable for the applicant.

- 2) Such a site inspection shall be posted as a meeting of the Board pursuant to the Right-to-Know provisions of RSA 91-A. If there is a quorum present at the site inspection, minutes shall be kept.
- 3) All applications are conditioned upon the owner allowing access to the property, to the extent reasonable and necessary to properly review the application. Denial of access automatically terminates any further consideration of the proposal.

**L. Concurrent and Joint Hearings**

The applicant or the Planning Board may request a joint hearing with one or more land use boards in conjunction with a subdivision hearing if approval from all boards is required for the same project.

**SECTION VI. SUBMISSION REQUIREMENTS**

A completed application shall consist of the following items unless written request for waiver(s) is granted by the Board:

**A. A completed application form, accompanied by:**

1. names and addresses of all abutters, taken from the town records not more than five (5) days before the day of filing;
2. names and addresses of all persons whose name and seal appears on the plat;
3. names and addresses of all holders of conservation, preservation or agricultural preservation restrictions;
4. payment to cover filing and notification fees;
5. one (1) mylar and three (3) paper copies of the Plat, prepared according to the standards of the NH Land Surveyors Association and the County Register of Deeds, as follows:
  - a. Plats shall be at any scale between 1"= 20' and 1"=400'.
  - b. The outside dimensions of the plat shall be 8½" X 11", 11" X 17", 17" X 22", or 22" X 34", or as otherwise specified by the County Registry of Deeds.
  - c. The material composition shall be suitable for electronic scanning and archiving by the Registers of Deeds.
  - d. All plats shall have a minimum ½" margin on all sides.
  - e. All title blocks should be located in the lower right hand corner, and shall indicate:
    - 1) type of survey
    - 2) owner of record

- 3) title of plan
  - 4) name of the town(s)
  - 5) tax map and lot number
  - 6) plan date and revision dates;
6. a letter of authorization from the owner, if the applicant is not the owner.

**B.** The plat shall show the following information:

- 1. Proposed subdivision name or identifying title; name and address of the applicant and of the owner, if other than the applicant.
- 2. North arrow, scale - written and graphic, date of the plan; name, license number and seal of the surveyor or other person whose seal appears on the plan.
- 3. Signature block for Planning Board endorsement.
- 4. Locus plan showing general location of the total tract within the town and the zoning district(s).
- 5. Boundary survey including bearings, horizontal distances and the location of permanent markers. Curved boundary lines shall show radius, delta, and length.
- 6. Names of all abutting subdivisions, streets, easements, building lines, parks and public places, and similar facts regarding abutting properties.
- 7. Location of all property lines and their dimensions; lot areas in square feet and acres. Lots numbered according to the Town tax map numbering system.
- 8. Location and amount of frontage on public rights-of-way.
- 9. Location of building setback lines.
- 10. Location of existing and proposed buildings and other structures.
- 11. Location of all parcels of land proposed to be dedicated to public use.
- 12. Location and description of any existing or proposed easements.
- 13. Existing and proposed water mains, culverts, drains, sewers; proposed connections or alternative means of providing water supply and disposal of sewage and surface drainage.
- 14. Existing and proposed streets with names, classification, travel surface widths, right-of-way widths. (See Appendix A for road standards.)
- 15. Final road profiles, center line stationing and cross sections.

16. Location and width of existing and proposed driveways.
17. Water courses, ponds, standing water, rock ledges, stone walls; existing and proposed foliage lines; open space to be preserved; and any other man-made or natural features.
18. Existing and proposed topographic contours based upon the USGS topographical data, with spot elevations where necessary.
19. Soil and wetland delineation (see Appendix B).
20. Location of percolation tests and test results; certification of Town official witnessing the tests; and outline of 4,000 square-foot septic area with any applicable setback lines;
21. Location of existing and proposed well, with 75-foot well radius on its own lot.
22. Base flood elevations and flood hazard areas, based on available FEMA maps.

**C. Other Information**

- 1) Plan for Stormwater Management and Erosion Control, if applicable (See Section VII).
- 2) State subdivision approval for septic systems; septic design approval where applicable; or certification by septic designer of adequacy of existing system.
- 3) Alteration of Terrain Permit from NH Department of Environmental Services.
- 4) State/Town driveway permit, as applicable.
- 5) Report from the Fire Chief, Police Chief, and/or Town Conservation Commission.
- 6) Approval for municipal water/sewer connections.
- 7) Any deed restrictions; and all deeds covering land to be used for public purposes, easements and rights-of-way over property to remain in private ownership, and rights of drainage across private property, submitted in a form satisfactory to the Board's counsel.
- 8) Any other state and/or federal permits.
- 9) Any additional reports or studies deemed necessary by the Board to make an informed decision, including but not limited to: traffic, school, fiscal and environmental impact analyses. The Board reserves the right to request such information after an application has been accepted as complete, as well as before acceptance.

Should the Board determine that some or all of the above-described information is to be required, the applicant will be notified in writing within ten (10) days of the meeting at which the determination was made.

## SECTION VII. SUBDIVISION DESIGN STANDARDS

### A. Lots

1. Areas set aside for parks and playgrounds to be dedicated or reserved for the common use of all property owners shall be of reasonable size and character for neighborhood playgrounds or other recreational uses.
2. Lots shall be laid out and graded to eliminate flood or stagnant water pools. No water shall be permitted to run across a street on the surface, but shall be directed into catch basins and pipes underground in a pipe of not less than 12 inches in diameter.

- B. **Reserve Strips**: Reserve strips of land that show an intent on the part of the subdivider to control access to land dedicated or to be dedicated to public use (such as a road) shall not be permitted.

### C. Fire Protection

Applications for new subdivisions shall be required to address water supply needs for fire protection. The Fire Chief shall review all proposals to determine whether or not water supply should be addressed for that particular proposal; if so, the following requirements apply:

1. The Fire Chief shall complete an inspection of the proposed site to evaluate the availability of existing water supply in the area.
2. The Fire Chief shall implement all applicable provisions of the National Fire Prevention Association's Standard on Water Supplies for Suburban and Rural Fire Fighting.
3. The Fire Chief shall determine the type, location and spacing of any water supply (such as fire ponds, cisterns, etc.)
4. Following the inspection and evaluation, the Fire Chief will submit his findings in writing to the Planning Board.
5. All proposed developments, whether including the provision of hydrants or other water supply facilities, shall be accessible to firefighting and other emergency equipment.

### D. Septic systems and Water Supply

1. In areas not currently served by public sewer systems, it shall be the responsibility of the subdivider to prove that the area of each lot is adequate to permit the installation and operation of an individual septic system.
2. On new lots of less than five (5) acres, not less than two (2) test pits and at least one (1) percolation test shall be required within the 4,000 square-foot area designated for a leach field. The subdivider shall be required to provide the necessary equipment and labor for the making of these tests, which shall be overseen by the Town Health Officer.
3. In subdividing parcels with existing dwellings, the subdivider must demonstrate to the satisfaction of the Board that the existing septic

system is in good working order.

3. All new wells shall have a radius of seventy-five (75) feet, said radius to be located entirely on its lot. When that cannot be accomplished, the protective radius shall be maximized to the extent practicable. The 75-foot radius may extend over the property line(s) with written consent of the abutter(s).

**E. Stormwater Management and Erosion Control**

1. The applicant shall submit stormwater management and erosion control plans when one or more of the following conditions are proposed:
  - a. A cumulative disturbed area exceeding 20,000 square feet.
  - b. Construction of a street or road.
  - c. A subdivision involving three or more dwelling units.
  - d. The disturbance of critical areas, such as steep slopes, wetlands, floodplains.
2. Standard agricultural and silvicultural practices are exempt from this regulation.
3. All stormwater management and erosion control measures in the plan shall adhere to the "Erosion and Sediment Control Design Handbook for Developing Areas of New Hampshire", published by the Rockingham County Conservation District, and the "Model Stormwater Management and Erosion Control Regulation", by the NH Association of Conservation Districts, Water Quality Committee.
4. The applicant shall bear final responsibility for the installation, construction, and disposition of all stormwater and erosion control measures required by the Board. Site development shall not begin before the plan is approved.

**F. Surveys**

All surveys shall be prepared according to the minimum standards for instrument surveys adopted by the NH Land Surveyors Association for Standard Property Surveys, as follows:

<u>Condition</u>	<u>"1"</u>	<u>"2"</u>	<u>"3"</u>
Unadjusted Linear Closure	1:15,000	1:7,500	1:300
Minimum Scale Graduation of Instrument	20/sec.	30/sec.	1
Distance Measurement	EDM/ Steel Tape	EDM/ Steel Tape	Steel Tape/ Stadia
Elevation Used to Determine Property Lines	0.2' +/-	0.5' +/-	-----

Condition "1" shall be required for any subdivision of less than 2 acres

that involves building of any kind - i.e., residential, commercial or industrial.

Condition "2" is adequate for subdivisions of 2 acres or more in a rural district.

Condition "3" is acceptable for subdivisions involving woodlots, timber lots, or large tracts being dedicated to preservation or conservation. The standards of Condition "3" may be achievable with a tape & compass survey.

In the case of applications that involve large acreages from which one building lot is being subdivided, the Board may, upon written request, waive the requirement for a complete boundary survey, when it is apparent that the remaining lot can meet existing frontage requirements and issuitable for building.

**G. Monumentation**

1. Monuments constructed of concrete or stone at least 4 inches square on the top and at least 30 inches long shall be set at all control corners.
2. If the subdivision involves the construction of a roadway, all monumentation shall be in place before 50% of the surety held for the construction is released. If no road construction is involved, all monumentation must be in place prior to the signing of the plat by the Board Chairman.
3. Pipes shall be set at all lot corners. Concrete or granite bounds shall be set at all points of curvature and all points of tangent for surveying purposes.
4. Monuments shall be tied in to a public street intersection, a U.S.G.S. benchmark, or other recognized existing monument.

**SECTION VIII. DEVELOPMENTS HAVING REGIONAL IMPACT**

- A. All applications shall be reviewed for potential regional impacts. Upon such a finding, the Board shall furnish the regional planning commission(s) and the affected municipalities with copies of the minutes of the meeting at which the determination was made. The copies shall be sent by certified mail within 72 hours of the meeting.
- B. At least 14 days prior to the scheduled public hearing, the Board shall notify by certified mail the regional planning commission(s) and the affected municipalities of the date, time and place of the hearing, and of their right to appear as abutters to offer testimony concerning the proposal.

**SECTION IX. PREVIOUSLY-APPROVED SUBDIVISIONS**

If any land shown on a subdivision plat has been part of any previous subdivision approved, constructed, or created by conveyance no more than 7 years prior to the new proposal, any such previous subdivision will be treated as part of the new proposal for purposes of analyzing its effect and applying all review criteria.

**SECTION X. SPECIAL FLOOD HAZARD AREAS**

- A. The Planning Board shall review the proposed development to assure that all necessary permits have been received from those governmental agencies from which approval is required by Federal or State law, including Section 404 of the Federal Water Pollution Control Act Amendments of 1972, 33 U.S.C. 1334.
- B. The Board shall require that all subdivision proposals and other proposed new developments greater than 50 lots or 5 acres, whichever is the lesser, include base flood elevation data. Sufficient evidence (construction drawings, grading and land treatment plans) shall be submitted so as to allow determination that:
- 1) *all such proposals are consistent with the need to minimize flood damage;*
  - 2) *all public utilities and facilities, such as sewer, gas, electrical, and water systems are located and constructed to minimize or eliminate flood damage; and*
  - 3) *adequate drainage is provided so as to reduce exposure to flood hazards.*

**SECTION XI. PERFORMANCE GUARANTEE**

- A. As a condition of approval, the Board shall require the posting of a security in an amount sufficient to defray the costs of construction of streets and public utilities. The amount of the security shall be based on an estimate of costs provided by the subdivider and, at the discretion of the Planning Board, reviewed by a licensed engineer. All costs of such review shall be paid by the applicant.
- B. The security shall be approved by the Board and municipal counsel. The amount of the security shall include fees to cover the cost of periodic inspections.
- C. Where electric lines or other utilities are to be installed by a corporation or public utility, a letter of intent shall be required stating that the work will be done in reasonable time and without expense to the Town.
- D. Each approved plat shall contain a time limit for the completion of streets and public improvements. The performance guarantee shall be released in phases as portions of the secured improvements or installations are completed and approved by the Board or its designee, in accordance with the plan approved by the Board. In the case of road construction, the Board may require that the security stay in place until one full year has passed after completion of the road.

**SECTION XII. REVOCATION OF PLANNING BOARD APPROVAL**

An approved and recorded subdivision plat may be revoked by the Board in whole or in part, under the following circumstances: (1) at the request of or by agreement with the applicant; (2) when any requirement or condition of approval has been violated; (3) when the applicant has failed to perform any condition of approval



within the time specified or within four years; (4) when four years have elapsed without any vesting of rights and the plan no longer conforms to applicable regulations; or (5) when the applicant has failed to provide for the continuation of adequate security.

### **SECTION XIII. ADMINISTRATION AND ENFORCEMENT**

- A. These regulations shall be administered by the Planning Board. The enforcement of these regulations is vested with the Selectmen.
- B. No subdivision regulation or amendment, adopted under RSA 674:35-42, shall be legal or have any force and effect until copies of such are filed with the Town Clerk.
- C. **Waivers**: The requirements of these regulations may be waived or modified when, in the opinion of the Board, specific circumstances surrounding subdivision, or the condition of the land in such subdivision, indicate that such modifications will properly carry out the purpose and intent of the master plan and these regulations.
- D. **Penalties and Fines**: Any violation of these regulations shall be subject to a civil fine as provided in RSA 676:16 and 676:17, as amended.

### **SECTION XIV. APPEALS**

Any person aggrieved by a decision of the Planning Board concerning a plat or subdivision may appeal said decision to the Housing Appeals Board pursuant to RSA 679, except when a disapproval by the Board is based upon non-compliance with the zoning ordinance, in which case an appeal can be taken to the Board of Adjustment.

### **SECTION XV. VALIDITY**

If any section or part of a section or paragraph of these regulations shall be declared invalid or unconstitutional, it shall not be held to invalidate or impair the validity, force or effect of any other section or part of a section or paragraph of these regulations.

### **SECTION XVI. AMENDMENTS**

These regulations may be amended by a majority vote of the Planning Board after at least one (1) public hearing following the notification procedure outlined in Section IV, H & I.

### **SECTION XVII. EFFECTIVE DATE**

These regulations shall take effect upon their adoption, and all regulations or parts of regulations, inconsistent therewith, are hereby repealed.

<b>CHECKLIST FOR LOT LINE ADJUSTMENT OR TECHNICAL SUBDIVISION</b>
---

APPLICANT NAME/APPLICATION NUMBER \_\_\_\_\_

DATE OF APPLICATION \_\_\_\_\_

The items on this page are considered to be the minimum requirements for a lot line adjustment or technical subdivision, where no new lots are being created. The Board reserves the right, however, to request additional information if, in its judgement, the data are necessary in order to make an informed decision.

<b>SUBMITTED</b>			<b>WAIVED</b>	
<u>YES</u>	<u>NO</u>		<u>YES</u>	<u>NO</u>
___	___	1. Name of subdivision; name and address of subdivider.	___	___
___	___	2. Name, license number and seal of surveyor or other persons preparing the plan.	___	___
___	___	3. Names and addresses of all abutters and all holders of conservation, preservation, or agricultural preservation easements (on the plat or on separate sheet).	___	___
___	___	4. North arrow, scale, and date of plan.	___	___
___	___	5. Signature block for Planning Board endorsement.	___	___
___	___	6. Locus plan, showing zoning designations.	___	___
___	___	7. Boundary survey and location of permanent markers.	___	___
___	___	8. Location of property lines, lot areas in square feet and acres; lots numbered according to Town tax map system.	___	___
___	___	9. Location and amount of frontage on public right-of-way; names, classification of abutting streets.	___	___
___	___	10. Building setback lines.	___	___
___	___	11. Location of existing buildings and other structures.	___	___
___	___	12. Location of existing driveways.	___	___
___	___	13. Location and description of any existing or proposed easements or public dedications.	___	___

## SUBDIVISION CHECKLIST

APPLICANT NAME/APPLICATION NUMBER \_\_\_\_\_

DATE OF APPLICATION \_\_\_\_\_

This checklist is to be used for all subdivisions. However, the Planning Board may, at its discretion, waive items deemed to be irrelevant (e.g. topographic or soils data) for a particular subdivision. The Board, reserves the right to require that all items be met if, in its judgement, the data are necessary in order to make an informed decision.

IS THIS A DEVELOPMENT HAVING REGIONAL IMPACT?		YES	NO
<b>SUBMITTED</b>			<b>WAIVED</b>
<u>YES</u>	<u>NO</u>		<u>YES</u> <u>NO</u>
___	___		___
	1. Name of subdivision; name and address of subdivider.		___
___	___		___
	2. Name, license number and seal of surveyor or other persons; north arrow, scale, and date of plan.		___
___	___		___
	3. Signature block for Planning Board endorsement.		___
___	___		___
	4. Locus plan, showing zoning designations.		___
___	___		___
	5. Names and addresses of all abutters and all holders of conservation, preservation, or agricultural preservation easements (on the plat or on separate sheet).		___
___	___		___
	6. Boundary survey and location of permanent markers.		___
___	___		___
	7. Names of abutting subdivisions, streets, driveways, easements, building lines, parks/public spaces, notation of use of abutting land, and similar facts regarding abutting properties.		___
___	___		___
	8. Location of property lines, lot areas in square feet and acres; lots numbered according to Town tax map system.		___
___	___		___
	9. Location and amount of frontage on public right-of-way.		___
___	___		___
	10. Location of building setback lines.		___
___	___		___
	11. Existing and/or proposed buildings, other structures.		___

**Subdivision Checklist - Page 2**

<b>SUBMITTED</b>			<b>WAIVED</b>	
<b><u>Yes</u></b>	<b><u>No</u></b>		<b><u>Yes</u></b>	<b><u>No</u></b>
___	___	12. Location of any existing or proposed easements, land to be dedicated to public use.	___	___
___	___	13. Existing and proposed water mains, culverts, drains, sewers; proposed connections or alternative means of providing water supply and sewage disposal.	___	___
___	___	14. Existing and proposed streets, with names, classification, width of travel surface and rights-of-way.	___	___
___	___	15. Final road profiles, centerline stationing, cross sections.	___	___
___	___	16. Location and width of existing and proposed driveways.	___	___
___	___	17. Location of all surface water, wetlands, rock ledges, stone walls, open space to be preserved, and any other man-made or natural features.	___	___
___	___	18. Existing and proposed topographic contours.	___	___
___	___	19. Soil and wetland delineation (Appendix B).	___	___
___	___	20. Location of perc tests, test results, outline of 4,000 square-foot septic area, applicable septic setback lines.	___	___
___	___	21. Location of existing and proposed wells, with 75-foot radius on property.	___	___
___	___	22. Base flood elevations.	___	___
<b><u>OTHER:</u></b>				
___	___	23. Plans for stormwater management and erosion control.	___	___
___	___	24. Copy of state subdivision approval for septic system.	___	___
___	___	25. Alteration of Terrain Permit.	___	___
___	___	26. Town or DOT Driveway Permit	___	___
___	___	27. Copy of any deed restrictions.	___	___
___	___	28. Any additional reports or studies.	___	___

# SITE PLAN REVIEW REGULATIONS

ADOPTED BY THE PLANNING BOARD ON JUNE 14, 2022  
AFTER PUBLIC HEARING ON JUNE 14, 2022

# SITE PLAN REVIEW REGULATIONS

## TABLE OF CONTENTS

SECTION I.	AUTHORITY . . . . .	SPR	1
SECTION II.	PURPOSE . . . . .	SPR	1
SECTION III.	SCOPE OF REVIEW . . . . .	SPR	1
SECTION IV.	DEFINITIONS . . . . .	SPR	2
SECTION V.	APPLICATION PROCEDURES . . . . .	SPR	2
SECTION VI.	SUBMISSION REQUIREMENTS . . . . .	SPR	2
SECTION VII.	DEVELOPMENTS HAVING REGIONAL IMPACTS . . . . .	SPR	5
SECTION VIII.	SPECIAL FLOOD HAZARD AREAS . . . . .	SPR	5
SECTION IX.	PERFORMANCE GUARANTEE . . . . .	SPR	6
SECTION X.	GENERAL STANDARDS . . . . .	SPR	6
SECTION XI.	REVOCATION OF PLANNING APPROVAL . . . . .	SPR	9
SECTION XII.	ADMINISTRATION AND ENFORCEMENT . . . . .	SPR	9
SECTION XIII.	VALIDITY . . . . .	SPR	10
SECTION XIV.	AMENDMENTS . . . . .	SPR	10
SECTION XV.	EFFECTIVE DATE . . . . .	SPR	10
SECTION XVI.	SITE PLAN REVIEW CHECKLIST . . . . .	SPR	11

# SITE PLAN REVIEW REGULATIONS

## SECTION I. AUTHORITY

Pursuant to the authority vested in the Planning Board by the voters of the Town of Roxbury, and in accordance with the provisions of 674:43 and 44, New Hampshire Revised Statutes Annotated, as amended, the Roxbury Planning Board hereby adopts the following regulations ***governing the development or change or expansion of use of tracts for nonresidential uses or multi-family dwelling units*** (more than two units), whether or not such development includes a subdivision or resubdivision of the site.

## SECTION II. PURPOSE

The purpose of the Site Plan Review process is to protect the public health, safety and welfare;; to promote the timing of development to prevent premature and uncoordinated development of land without the adequate provision of public services and facilities; to ensure sound site utilization; to avoid development which may result in negative environmental impacts; and to guide the character of development. The Site Plan Review Procedure in no way relieves the developer or his/her agent from compliance with the Zoning Ordinance, Subdivision Regulations or any other ordinance which pertains to the proposed development. No site plan will be approved until it complies in all respects with any and all pertinent ordinances and regulations.

## SECTION III. SCOPE OF REVIEW

Whenever any development or change or expansion of use of a site is proposed or whenever any changes are proposed that differ from an existing site plan as previously approved by the Planning Board; before any construction, land clearing, building development or change is begun and before any permit for the erection of any building or authorization for development on such site shall be granted, the owner of the property or his authorized agent shall apply for and secure from the Planning Board approval of such proposed site development in accordance with procedures outlined in this regulation.

The Planning Board shall have the responsibility for making the final decision as to the necessity of Site Plan Review. Where there is any doubt as to whether or not a project requires Site Plan Review, the affected party should request a determination from the Board. In an effort to clarify what constitutes a change of use of sufficient magnitude or impact to trigger Planning Board action, the following guidelines will be observed:

- 1. If the proposal involves new construction of non-residential or multi-family development.*
- 2. If the proposal involves a change of use category, e.g., from residential to commercial, or from single family to multi-family.*
- 3. If the proposal involves external modifications or construction, including parking lots (except for single family or duplex housing).*
- 4. If the proposal involves expansion of a building or intensification of use that would result in a change in traffic volume or patterns in the area, noise, parking, lighting, etc.*

5. *If the proposal involves a property that has never received Site Plan Review from the Planning Board for previous non-residential or multi-family use.*

**A. Activities Not Subject to Site Plan Review**

1. *Proposals that involve no change in use or level of activity.*
2. *Internal building modifications to a non- residential use that do not affect the scale or impact of the existing use.*
3. *A re-use of a premise for which a Site Plan Review has already been conducted, provided the new use is not different in type or impact.*

**SECTION IV. DEFINITIONS**

The definitions contained in the Roxbury Zoning Ordinance and the Subdivision Regulations shall apply to these Regulations.

**SECTION V. APPLICATION PROCEDURE**

The application procedures as outlined in the Roxbury Subdivision Regulations shall apply to Site Plan Review.

**A. Expedited Review**

The Board may provide for an expedited review of minor site plans. Criteria the Board will use to determine whether an application qualifies as a minor site plan include, but are not limited to, the following:

1. *When there is no new construction.*
2. *When new construction is no greater than 2,500 square feet in area.*
3. *When site impacts are not expected to be significant, in terms of traffic, noise, parking, lighting, etc.*

Under the expedited review procedure, the Board may waive certain submission requirements, such as the need to have an engineered plan, or a plan filed with the Register of Deeds.

**SECTION VI. SUBMISSION REQUIREMENTS**

A completed application shall consist of the following items unless a written request for waiver(s) is granted by the Board:

- A.** A completed application form, accompanied by:
1. names and addresses of all abutters, taken from the town records not more than five (5) days before the day of filing;
  2. names, addresses and seal of all persons preparing the plat, as applicable;
  3. names and addresses of all holders of conservation, preservation or agricultural preservation restrictions;



4. payment to cover filing and notification fees;
5. one (1) mylar and three (3) paper copies of the Plat, prepared according to the standards of the NH Land Surveyors Association and the County Register of Deeds, as follows:
  - a. Plats shall be at any scale between 1"= 20' and 1"=400'.
  - b. The outside dimensions of the plat shall be 8½" X 11", 11" X 17", 17" X 22", or 22" X 34", or as may be otherwise specified by the County Registry of Deeds.
  - c. The material composition shall be suitable for electronic scanning and archiving by the Registers of Deeds.
  - d. All plats shall have a minimum ½" margin on all sides.
  - e. All title blocks should be located in the lower right hand corner, and shall indicate:
    - 1) type of survey
    - 2) owner of record
    - 3) title of plan
    - 4) name of the town(s)
    - 5) tax map and lot number
    - 6) plan date and revision dates;
6. a letter of authorization from the owner, if the applicant is not the owner.

**B. Plat Submission Items**

1. Name of project or identifying title; names and addresses of owners of record; and tax map and lot number.
2. North arrow, date of the plat, scale appropriate to the scope of the development; name and address of person preparing the plat; signature block for Planning Board approval.
3. Vicinity sketch at an appropriate scale showing the location of the site in relation to the existing public streets; and the zoning district(s).
4. Physical features and uses of abutting land within 200 feet of the site.
5. Boundary lines, their source, approximate dimensions and bearings, and the lot area in acres and square feet.
6. The shape, size, height, location and use of existing and proposed structures located on the site and those existing within 200 feet of the site.
7. Location, name and widths of any existing and proposed roads on the property and those existing within 200 feet of the site. New roads shall be constructed in accordance with the provisions contained in The Roxbury Subdivision Regulations.
8. Final road profiles, center line stationing and cross sections.
9. Location of existing and proposed sidewalks and driveways, with indication of direction of travel for any which are one-way. Both vehicular and pedestrian circulation shall be shown.

10. Identification of access to the site, sight distance at the access point(s), curb cuts and proposed changes (if any) to existing streets; and copy of any driveway permit(s).
11. Location and total number of parking spaces; loading spaces and other similar facilities associated with the use.
12. A landscape plan, describing the number, location, types, and size of all existing and proposed landscaping and screening.
13. The location, type, and nature of all existing and proposed exterior lighting and signage.
14. Water courses, ponds, standing water, rock ledges, stone walls; existing and proposed foliage lines; open space to be preserved; and any other man-made or natural features.
15. The size and location of all existing and proposed water mains, sewers, culverts, proposed connections or alternative means of providing water supply and disposal of sewage and surface drainage.
16. The location and distance to any fire hydrants and/or fire ponds.
17. Existing and proposed topographic contours based upon the USGS topographical data, with spot elevations where necessary.
18. Soil and wetland delineation (see Appendix B).
19. Location of percolation tests and test results; certification of Town official witnessing the tests; and outline of 4,000 square-foot septic area with any applicable setback lines;
20. Location of existing and proposed well, with 75-foot radius on its own lot.
21. Copy of certification by a licensed septic designer that an existing system is adequate to meet the needs of the proposed use.
22. Location of any existing or proposed easements, deed restrictions, covenants.
23. Base flood elevations and flood hazard areas, based on available FEMA maps.

**B. Other**

1. Plan for Stormwater Management and Erosion Control, if applicable (See Section X).
2. State subdivision approval for septic systems; septic design approval where applicable; or certification by septic designer of adequacy of existing system.
3. Alteration of Terrain Permit from NH Department of Environmental Services.
4. State/Town driveway permit, as applicable.
5. Report from the Fire Chief, Police Chief, and/or Town Conservation Commission.

6. Approval for municipal water/sewer connections.
7. Any deed restrictions; and all deeds covering land to be used for public purposes, easements and rights-of-way over property to remain in private ownership, and rights of drainage across private property, submitted in a form satisfactory to the Board's counsel.
8. Any other state and/or federal permits.
9. An impact analysis may be required, which takes into account the following items to the extent the Board deems applicable:
  - a) *Demographic Description*
  - b) *Community Facilities Impacts*
  - c) *Environmental Impacts*
10. Any additional reports or studies deemed necessary by the Board to make an informed decision.

Should the Board determine that some or all of the above-described information is to be required, the applicant will be notified in writing within ten (10) days of the meeting at which the determination was made.

**C. "As Built" Plans**

Supplemental information may be required by the Board to update the final plat to reflect "as built" conditions and details. The plan shall show any easements and dedicated roadways. A security bond may be required to guarantee performance of the applicant's obligations as described herein.

**SECTION VII. DEVELOPMENTS HAVING REGIONAL IMPACT**

All applications shall be reviewed for potential regional impacts. Upon such a finding, the Board shall furnish the regional planning commission(s) and the affected municipalities with copies of the minutes of the meeting at which the determination was made. The copies shall be sent by certified mail within 72 hours of the meeting. At least 14 days prior to the scheduled public hearing, the Board shall notify by certified mail the regional planning commission(s) and the affected municipalities of the date, time and place of the hearing, and of their right to appear with the status of abutters to offer testimony concerning the proposal.

**SECTION VIII. SPECIAL FLOOD HAZARD AREAS**

- A. The Planning Board shall review the proposed development to assure that all necessary permits have been received from those governmental agencies from which approval is required by Federal or State law, including Section 404 of the Federal Water Pollution Control Act Amendments of 1972, 33 U.S.C. 1334.
- B. The Board shall require that all subdivision proposals and other proposed new developments greater than 50 lots or 5 acres, whichever is the lesser, include within such proposals base flood elevation data. Sufficient evidence (construction drawings, grading and land treatment plans) shall be submitted so as to allow determination that:

- 1) *all such proposals are consistent with the need to minimize flood damage;*
- 2) *all public utilities and facilities, such as sewer, gas, electrical, and water systems are located and constructed to minimize or eliminate flood damage; and*
- 3) *adequate drainage is provided so as to reduce exposure to flood hazards.*

## **SECTION IX. PERFORMANCE GUARANTEE**

As a condition of approval, the Planning Board shall require the posting of a security in an amount sufficient to defray the costs of construction of streets and public utilities. The amount of the security shall be based on an estimate of costs provided by the applicant; the amount of the security shall also include fees to cover the cost of periodic inspections. At the discretion of the Planning Board, the proposed security shall be reviewed by a licensed engineer. All costs of such review shall be paid by the applicant.

The security shall be approved as to form and sureties by the Board and the municipal counsel. Where electric lines or other utilities are to be installed by a corporation or public utility, a letter of intent shall be required stating that the work will be done in a reasonable time and without expense to the Town. Each approved plat shall contain a time limit for the completion of all improvements. The performance guarantee shall be released in phases as portions of the secured improvements or installations are completed and approved by the Board or its designee, in accordance with the plan approved by the Board.

## **SECTION X. GENERAL STANDARDS**

**A. Design of development** should fit the existing natural and manmade environments with the least stress:

1. Site preparation is to be conducted with minimal disturbance to existing vegetation. Stripped topsoil is to be piled and reused on the site where needed. A minimum of 4 inches of topsoil is to be placed on the disturbed area. The site shall be adequately landscaped, as delineated in a landscape plan.
2. Landscape treatment shall consist of natural, undisturbed vegetation or features, or newly installed ground cover, shrubs, or trees where appropriate.
3. Grading and filling must be conducted to minimize the alteration of surface and subsurface drainage to, toward or across abutting properties, unless the written consent of the abutting landowner is obtained.

**B. Illumination:**

1. Outdoor lighting shall not glare on abutting properties or on public highways or streets.
2. Outdoor lighting is restricted to that which is necessary for advertising and security of the property.

**C. Pedestrian Safety:** Sidewalks shall be provided for pedestrian traffic to provide connection between the main entrances of business, housing or

industrial establishments and parking areas. In the event that pedestrian shoppers or employees are reasonably anticipated, provision shall be made for sidewalks running from the street line to the establishments. All such sidewalks shall be at least six (6) inches above grade and protected by curbing.

**D. Off-street Parking and Loading Requirements:**

1. Sufficient off-street loading and/or unloading space must be provided, including off-street areas for maneuvering of anticipated trucks or other vehicles. Maneuvers for parking and/or loading or unloading must not take place from a public street.
2. Access, parking and loading areas are to be constructed so as to minimize dust, erosion, and runoff conditions that would have a detrimental effect on abutting or neighboring properties.
3. Permeable pavement may be used which might reduce the need for installation of drainage facilities to accommodate runoff; however, the Board may require that access, parking and loading areas be conventionally paved, if deemed appropriate.
4. In site plans of more than one (1) use, the aggregate number of parking spaces shall be apportioned based on the various uses, with respective areas designated on the plan.

**E. Screening: Appropriate screening/buffers are to be maintained or installed to provide privacy and noise reduction to residential areas abutting nonresidential sites:**

1. Buffer strips (10 feet minimum - distance largely dependent upon the density of development in the area) must be maintained between proposed use and residential uses. Buffer strip between nonresidential and residential uses must contain vegetation that will screen nonresidential uses from sight of the residential uses during winter months.
2. Storage areas must be fenced or screened from on-site or adjoining parking and neighboring properties.
3. Litter (garbage) collection areas must be screened.
4. The use of either fencing or hedges is permitted.

**F. Street Access/Traffic Pattern: Access to public streets will meet the requirements of the NH Department of Transportation and/or the Town of Roxbury. Any new road construction shall conform to the road standards as specified in the Roxbury Subdivision Regulations. The internal traffic pattern will accommodate the proposed use, as well as providing easy, unimpeded access for emergency vehicles.**

**G. Water Supply and Sewage Disposal Systems must be sized to adequately meet the needs of the proposed use under the regulations of the NH Water Supply and Pollution Control Commission and/or the Town of Roxbury regulations. It shall be the responsibility of the applicant to provide adequate information to prove that the area of the lot is adequate to permit the installation and operation of an individual sewerage disposal system, and that existing systems are adequate to serve the needs of the proposed development.**

**H. Fire Protection**

Applications for new subdivisions shall be required to address water supply needs for fire protection. The Fire Chief shall review all proposals to determine whether or not water supply should be addressed for that particular proposal; if so, the following requirements apply:

1. The Fire Chief shall complete an inspection of the proposed site to evaluate the availability of existing water supply in the area.
2. The Fire Chief shall implement all applicable provisions of the National Fire Prevention Association's Standard on Water Supplies for Suburban and Rural Fire Fighting.
3. The Fire Chief shall determine the type, location and spacing of any water supply (such as fire ponds, cisterns, etc.)
4. Following the inspection and evaluation, the Fire Chief will submit his findings in writing to the Planning Board.
5. All proposed developments, whether including the provision of hydrants or other water supply facilities, shall be accessible to firefighting and other emergency equipment.

**I. Stormwater Management and Erosion Control**

1. The applicant shall submit stormwater management and erosion control plan when one or more of the following conditions are proposed:
  - a. *A cumulative disturbed area exceeding 20,000 square feet.*
  - b. *Construction of a street or road.*
  - c. *A subdivision involving three or more dwelling units.*
  - d. *The disturbance of critical areas, such as steep slopes, wetlands, floodplains.*
2. Standard agricultural and silvicultural practices are exempt from these provisions.
3. All stormwater management and erosion control measures in the plan shall adhere to the "Erosion and Sediment Control Design Handbook for Developing Areas of New Hampshire", published by the Rockingham County Conservation District, and the "Model Stormwater Management and Erosion Control Regulation", published by the NH Association of Conservation Districts, Water Quality Committee.
4. The applicant shall bear final responsibility for the installation, construction, and disposition of all stormwater and erosion control measures required by the Board. Site development shall not begin before the plan is approved.

**J. Underground fuel storage tanks** shall comply with the standards of the NH Water Supply and Pollution Control Division, as set forth in Part Env-WS 411, NH Code of Administrative Rules.

**K. Noise:**

In lieu of any other regulations governing noise in the Town, the following provisions shall apply:

- 1. Noise levels shall not exceed the standards set forth below (measured in DB(A)'s):

	<u>DAYTIME</u>	<u>NIGHTTIME</u>
Residential Uses	60	50
Commercial Uses	65	55
Industrial Uses	70	65

- 2. Daytime hours are between 7 A.M. and 8 P.M. Nighttime hours are between 8 P.M. and 7 A.M.
- 3. Measurements shall be made at the property line, at least four (4) feet from ground level, using a soundlevel meter meeting the standards prescribed by the American National Standards Institute.
- 4. Construction authorized by a building permit allows an increase to 75 DBA for daytime hours.

**L. Pollution Control:** To avoid undesirable and preventable elements of pollution such as noise, smoke, soot, particulate, or any other discharges into the environment which might prove harmful or a nuisance to persons, structures, groundwater, or adjacent properties is that the applicant will employ the best standards and technology economically available at the time.

**M. Protection of Natural and Historic Features:** All significant natural and historic features on the site, such as large or unusual trees, natural stone outcroppings, stone walls, etc. shall be shown on the plan. Board approval shall be obtained before removal of such features.

**N.** Where required by law, all buildings shall have access for handicapped persons.

**O.** Where appropriate, installation of any new utilities and/or transmission lines shall be buried underground.

**SECTION XI. REVOCATION OF PLANNING BOARD APPROVAL**

An approved and recorded subdivision plat may be revoked by the Board in whole or in part, under the following circumstances: (1) at the request of or by agreement with the applicant; (2) when any requirement or condition of approval has been violated; (3) when the applicant has failed to perform any condition of approval within the time specified or within four years; (4) when four years have elapsed without any vesting of rights and the plan no longer conforms to applicable regulations; or (5) when the applicant has failed to provide for the continuation of adequate security.

**SECTION XII. ADMINISTRATION AND ENFORCEMENT**

**A.** These regulations shall be administered by the Planning Board. The enforcement of these regulations is vested with the Selectmen. The Selectmen shall not issue any building permit for construction that requires site plan approval until or unless such planned construction has received site plan approval by the Planning Board.

- B. **Waivers**: Any portion of these regulations may be waived or modified when, in the opinion of the Board, strict conformity would pose an unnecessary hardship to the applicant and such waiver would not be contrary to the spirit and intent of these regulations.
- C. **Penalties and Fines**: Any violation of these regulations shall be subject to a civil fine as provided in RSA 676:16 and 676:17, as amended.
- D. **Appeals**: Any person aggrieved by a decision of the Planning Board may appeal said decision to the Housing Appeals Board pursuant to RSA 679, except when a disapproval by the Board is based upon non-compliance with the zoning ordinance, in which case an appeal can be taken to the Board of Adjustment.

### **SECTION XIII. VALIDITY**

If any provision of these regulations shall be held invalid for any reason by a court, such holding shall not invalidate in any manner any other provision contained herein.

### **SECTION XIV. AMENDMENTS**

These regulations may be amended by a majority vote of the Planning Board after at least one (1) public hearing following the notification procedure outlined in Section IV, H & I.

### **SECTION XV. EFFECTIVE DATE**

These regulations, and any amendments thereto shall take effect upon their adoption, and all other site plan review regulations, or part thereof inconsistent therewith, are hereby repealed.



APPLICANT NAME/APPLICATION NUMBER \_\_\_\_\_

DATE OF APPLICATION \_\_\_\_\_

**SITE PLAN REVIEW CHECKLIST**

**IS THIS A DEVELOPMENT HAVING REGIONAL IMPACT?        YES                        NO**

**A.    PLAT SUBMISSION ITEMS**

<b>SUBMITTED</b>			<b>WAIVED</b>	
<b><u>YES</u></b>	<b><u>NO</u></b>		<b><u>YES</u></b>	<b><u>NO</u></b>
___	___	1. Name of project; names and addresses of owners of record; tax map and lot number.	___	___
___	___	2. North arrow, date of plat, scale, name, address and seal of person preparing plat; signature block.	___	___
___	___	3. Vicinity sketch and zoning district(s).	___	___
___	___	4. Names and addresses of all abutters and all holders of conservation, preservation, or agricultural preservation easements (on the plat or on separate sheet).	___	___
___	___	5. Boundary lines, approximate dimensions and bearings; lot area in acres and square feet.	___	___
___	___	6. Physical features and use of abutting land within 200 feet of the site.	___	___
___	___	7. Shape, size, height, location and use of existing and proposed structures located on the site and within 200 feet of the site.	___	___
___	___	8. Location, name and widths of any existing and proposed roads on the property and within 200 feet of the site.	___	___
___	___	9. Location of existing and proposed sidewalks and driveways, with indication of travel for both pedestrian and vehicular traffic.	___	___
___	___	10. Access to the site, sight distance at access point(s), curb cuts and any proposed changes to existing streets; copy of driveway permit.	___	___
___	___	11. Location and number of parking spaces; loading spaces.	___	___

**Site Plan Review Checklist - Page 2**

<b>SUBMITTED</b>			<b>WAIVED</b>	
<b><u>YES</u></b>	<b><u>NO</u></b>		<b><u>YES</u></b>	<b><u>NO</u></b>
___	___	12. Location, types, size of all existing and proposed landscaping and screening.	___	___
___	___	13. Location, type and nature of all existing and proposed exterior lighting and signage.	___	___
___	___	14. Surface water, rock ledges, stone walls, existing and proposed foliage lines; open space to be preserved; other natural features.	___	___
___	___	15. Size and location of all existing and proposed water mains, sewers, culverts, and distances to existing fire hydrants and/or fire ponds.	___	___
___	___	16. Existing and proposed grades and contours.	___	___
___	___	17. Soil and wetland delineation.	___	___
___	___	18. Location of test pits, test results; outline of 4,000 square-foot septic area with setback lines.	___	___
___	___	19. Location of existing and proposed on-site well (showing 75-foot radius on the property).	___	___
___	___	20. Location of any existing or proposed easements, deed restrictions, covenants.	___	___
___	___	21. Base flood elevations.	___	___
<b>B.</b>	<b>OTHER</b>			
___	___	1. Plan for Stormwater Management and Erosion Control.	___	___
___	___	2. State subdivision approval for septic; design approval, and/or certification of adequacy of existing system(s).	___	___
___	___	3. Alteration of Terrain Permit.	___	___
___	___	4. State/Town Driveway Permit.	___	___
___	___	5. Reports from Police, Fire, Conservation Commission.	___	___
___	___	6. Approval for municipal water/sewer connection.	___	___
___	___	7. Deed restrictions, easements, covenants; deeds for lands devoted to public use.	___	___
___	___	8. Any other state/federal permits.	___	___
___	___	9. Impact Analysis.	___	___

# APPENDICES

- A.** ROAD & DRIVEWAY DESIGN AND CONSTRUCTION STANDARDS
- B.** REQUIREMENTS FOR SOILS AND WETLANDS DATA
- C.** SAMPLE FORMS FOR PUBLIC NOTIFICATION
  - 1. SUBMISSION OF APPLICATION ONLY
  - 2. SUBMISSION OF APPLICATION/PUBLIC HEARING ON PROPOSAL
  - 3. PUBLIC HEARING ON PROPOSAL
  - 4. ABUTTER NOTICES FOR APPLICATION
  - 5. APPLICANT NOTICE FOR APPLICATION
  - 6. SURVEYOR NOTICE FOR APPLICATION
  - 7. APPLICATION FOR WAIVER OF SUBMISSION REQUIREMENT(S)
  - 8. NOTICE OF PLANNING BOARD DECISION
  - 9. NOTICE OF HEARING TO REVOKE PLANNING BOARD APPROVAL
  - 10. DECLARATION OF REVOCATION
  - 11. ADOPTION OR AMENDMENT TO SUBDIVISION/SITE PLAN REVIEW REGULATIONS
- D.** CRITERIA FOR DETERMINING REGIONAL IMPACT
- E.** PROCEDURAL FLOWCHART FOR APPLICATION REVIEW

**APPENDIX A:  
ROAD AND DRIVEWAY DESIGN AND CONSTRUCTION STANDARDS**

**I. ROAD DESIGN STANDARDS**

The purpose of these standards is to ensure safe vehicular and pedestrian travel on streets, public or private. Proper design requires the blending of safe roadway layout and grade with minimization of impacts on the existing terrain and environment. These standards are further intended to be flexible in consideration of different traffic volumes and terrain conditions.

**A. Arrangement of Streets**

The streets in a subdivision shall be properly arranged and coordinated with other existing or planned streets.

**B. Rights-of-Way**

No street or highway right-of-way shall be less than fifty (50) feet in width and may be required to be more if a greater width is warranted in the opinion of the Board. The apportioning of the street widths among roadway, sidewalks, and possible grass strips shall be subject to the approval of the Board.

**C. Dead-end Streets/Cul-de-Sacs**

Dead-end streets shall be equipped with a turn-around roadway at the closed end, as shown in Exhibit 2 following. The maximum grade through a cul-de-sac shall be 5%.

**D. Intersections**

Street intersections shall have a minimum angle of intersection of 60 degrees, with a preferable angle being 90 degrees. Property line radius at intersections shall be no less than 20 feet. Refer to Table 1 for other requirements.

**E. Street Names**

1. Streets that extend or are in alignment with streets of abutting or neighboring properties shall bear the same names of existing streets within the Town of Roxbury.
2. Other street names shall be approved by the Planning Board in a review process, after consultation with the Selectmen.
3. Precautions shall be taken to ensure street names are not duplicated or so similar to other street names as to cause confusion.

**F. Existing Street Conditions**

Where a subdivision requires undue expenditures by the Town to improve existing streets to conform to minimum requirements, the Board may disapprove such subdivision until the Selectmen shall certify that funds for the improvements have been assured by the municipality.

**G. Minimum Design Requirements**

1. New roads shall be designed to conform to the minimum standards established in Table 1 below and as shown on the attached Typical Roadway Cross Section (Exhibit 1). The roadway designs are based on average daily traffic volumes (ADT).

**TABLE 1:  
MINIMUM ROAD DESIGN STANDARDS**

<b>TRAFFIC LOAD</b>	<b>ADT 0-50</b>	<b>ADT 50-250</b>	<b>ADT 250-400</b>	<b>ADT 400-750 (or greater)</b>
Design Speed	20	20	30	35
Centerline Curve Radius	120	150	250	425
Roadway Width	18'	20'	22'	24'
Shoulder Width (each side)	2'	2'	3'	4'
Vertical Curve				
Crest:	15	15	30	50
Sag:K Values (min)	24	24	40	50
Sight Distance	150	200	300	350
Sight Distance @ Road Intersections	200	300	350	400
Profile Grade				
Minimum:	0.5%	0.5%	0.5%	0.5%
Maximum:	10%	9%	8%	7%
Minimum Platform @ Road Intersections	2%-50'	2%-75'	2%-100'	2%-100'
Minimum Pavement Radius @ Road Intersections	30'	30'	35'	40'

2. ADT should be determined by the manual entitled Institute of Transportation Engineers - Trip Generation. This may be supplemented by actual traffic data compiled for local roadway networks, applicable to the proposed project.
3. Where streets have the potential for extension through to other lands or other potential street networks, appropriate increases in the traffic volume estimates may be required at the discretion of the Planning Board. The Planning Board shall have the right and authority to increase design standards in such cases and in other cases where it is deemed appropriate.
4. For streets serving commercial/industrial areas, the Planning Board may require more restrictive requirements than shown in Table 1. These commercial/industrial roads shall at least meet the requirements of a "collector road."

**H. Curbing**

1. Curbing may be required by the Planning Board where it is deemed appropriate and necessary for the purposes of drainage, slope stability and/or pedestrian safety. Curbing allowed includes straight granite, sloped granite, and bituminous cape cod berm.
2. The construction of curbing shall be in accordance with the attached details (Exhibits 4, 5, and 6).

**I. Sidewalks**

When the Planning Board determines that sidewalks are necessary, they shall be not less than four (4) feet in width and conforming to the grades of the street, and may be constructed on only one or on both sides of the street.

**J. Bicycle Paths**

Based on subdivision density, traffic volumes, proximity to schools, parks, and other features, the Planning Board may determine that bicycle paths shall be provided as part of the proposed development. Such paths shall be a minimum of five (5) feet in width or, in cases where bicyclists and pedestrians would share a path, the minimum shall be eight (8) feet in width.

**K. Steep Grades**

Where roadway profiles exceed 5%, special consideration will be given to drainage, sedimentation and erosion protection. This may require curbing and special measures such as rip-rap or other erosion protection. In no case shall grades exceed 5% within at least 50 feet of an intersection.

**L. Superelevation**

Where superelevation is necessary, the design shall conform to the recommendations of AASHTO for the proposed rate of superelevation, and the Design Engineer shall provide appropriate documentation and calculations to demonstrate the safety and adequacy of the proposal.

**II. CONSTRUCTION STANDARDS**

**A. Subgrade:**

1. All trees and roots shall be stripped to below the base course of pavement and shoulders for the full width of the pavement and shoulders. All soft spots, peat, organic material, spongy soil, and other unsuitable materials shall be removed and replaced by material approved by the Board or its agent. The subgrade fill or backfill shall be compacted in lifts not exceeding 12 inches in depth. The subgrade shall be graded in the general cross slope configuration shown on the Typical Roads Section (Exhibits 1 or 3).
2. Boulders and/or ledge shall be removed to a depth of 6 inches below the subgrade level shown on the Typical Road Section (Exhibits 1 or 3). After removal to this depth they shall be covered by a fill material approved by the Board or its agent and graded and compacted to the subgrade level.

**B. Base Course:**

1. Bank-run gravel of good quality shall be spread over the entire width of the proposed pavement and shoulders to a depth of 12 inches, plus six (6) inches of crushed gravel.
2. The bank-run gravel and crushed gravel each shall be placed in lifts not exceeding six (6) inches and in the cross slope configuration shown on the attached Typical Roadway Section (Exhibits 1 or 3).

**C. Compaction:** Roadway subgrade and base courses shall be compacted to 95% of maximum density proctor method in accordance with AASHTO T-99.

**D. Pavement Materials:**

- Base Course of two (2) inches conforming to Type B of the NHDOT Specifications.
- "Wearing Course" conforming to Type F of the NHDOT Specifications.

**E.** Grades of all streets shall conform in general to the terrain and shall so far as practicable not exceed eight (8) percent. No street shall have a grade of less than one-half of one percent (.05%). Where practical, lots shall be graded toward the streets.

**F.** All slopes shall be graded, loamed, hayed and seeded. No slope, cut or fill will be greater than two horizontal to one vertical in ledge, or three horizontal to one vertical (3:1) in all other materials.

**G.** All proposed drainage facilities and culverts shall be installed. Natural watercourses shall be cleaned and increased in size where necessary to take care of storm runoff. Drainage swales at least three (3) feet in width and 16 inches in depth at its midpoint below centerline grade shall be constructed in the street right-of-way on both sides of the paved roadway. Drainage facilities must be adequate to provide for the removal of storm water to prevent flooding of the pavement and erosion of adjacent surfaces. Roadway drainage shall be sized to accommodate the 25-year rain event; internal drainage shall be sized to accommodate the 10-year rain event.

**H.** The recommendations of the Town Road Agent respecting locations of culverts, drainage, and type and quality of fill and subfill shall be followed.

**III. DRIVEWAY STANDARDS**

**A.** No driveway shall be constructed within 50 feet of the intersection of two public roads.

**B.** When two proposed driveways on the same side of the road are within 50 feet of each other, the Planning Board may require a common access to be used, for reasons of safety and topographical considerations.

**C.** The driveway shall have a minimum width of twelve (12) feet at the intersection of the street and for a distance of forty-eight (48) feet from the street. In all cases, the driveway shall be wide enough to

accommodate emergency vehicles. The driveway entrance may be flared as it approaches the road.

- D. The driveway entrance shall drop six (6) inches from the center of the road to a point at least six (6) feet in back of the ditch line.
- E. A minimum of 150 feet all season safe sight distance in each direction is required.
- F. If a culvert is required for proper drainage, the culvert shall be a minimum of 15 inches in diameter and shall be new galvanized steel or concrete. The culvert shall be long enough to maintain the driveway width dimensions, or at least a 3:1 side slope.
- G. The culvert may be required to have a catch basin with a cover at the inlet end and a concrete or stone header at the outlet end. The culverts shall be installed by the landowner under the supervision of the Road Agent.
- H. Driveways shall not interrupt the natural or ditch line flow of drainage water. Where shallow ditch lines or natural drainage courses exist, driveways may be swaled at a point beyond the shoulder to accommodate the flow of storm water.
- I. The drainage ditch shall be six (6) inches below the outlet end of the culvert and drop at least one-half inch to the foot for a distance to be determined by the Road Agent.
- J. Any driveway crossing a wetland or body of water shall have all permits required by the NH Wetlands Board.
- K. All bridges shall be constructed in accordance with NH State standards and as approved by the Planning Board.
- L. No structures (including buildings), permanent or portable signs, lights, displays, fences, walls, etc. shall be permitted on, over, or under the town road right-of-way.
- M. Driveways providing access for multi-unit residential, commercial, or industrial uses shall be designed to conform with good engineering practice using the NHDOT manual, Policy and Procedures for Driveways and Other Accesses to the State Highway System, as a guide.
- N. The contractor shall give 24-hour notice to the Road Agent before starting construction.
- O. Final approval by the Planning Board will be granted upon inspection and determination that all work has been satisfactorily completed.

#### **IV. DRIVEWAYS TO BACKLOTS**

Driveways to backlots shall be subject to the following standards, in addition to any other applicable standards spelled out in Section III above:

- A. Unless existing conditions prevent it, only one curb cut will be allowed for both the front and the back lot.



- B. All curb cuts on town streets or private roads are to be approved by the Road Agent. The location will be suitable, and the use and maintenance of the driveway will not create a hazard or nuisance.
- C. The edge of the traveled way shall be set back at least 10 feet from any property lines.
- D. Appropriate buffering shall be provided, to protect the privacy of neighbors and shield them from dust, noise, lighting, etc.
- E. There shall be a proper turnaround for emergency vehicles, subject to approval by the Town Fire Chief.

**V. PRIVATE ROADS**

In order to encourage interior development as an alternative to development exclusively or primarily on major roads and streets (so-called strip development), and to allow development at no additional cost to the Town, the Planning Board may approve the layout of roads to be built and maintained by the landowner(s) according to the following conditions:

- A. Before final approval of a private subdivision road, the Applicant shall post a bond or other surety to cover the cost of construction and maintenance of the road and utility lines, if any. Said guarantee shall remain in effect for a minimum of three (3) years and may be extended by the Planning Board for an additional period if deemed necessary, after a site inspection and recommendation by the Town Road Agent.
- B. A maintenance agreement shall accompany the plan to be recorded which states to what extent each parcelor lot is responsible for maintenance of the private road. The agreement shall run with the land, and upon any future conveyance of property, the agreement shall be incorporated in and made part of a conveyance binding upon the parties thereto, their successors and assignees.
- C. The Board may agree to a lesser standard of construction for a private road, with the understanding and agreement of the applicant that, should the Town ever decide to take over the road, it would have to be improved to Town road specifications.
- D. The Applicant shall sign a "Statement of Agreement" with the Town, indicating she/he understands that the Town is under no obligation to take over maintenance or ownership of the road.
- E. No private subdivision road will be approved by the Town or the Planning Board unless adequate provision is made for any utilities serving the site. The plan submitted must show the location and size of necessary utility easements; and if private lines are to be connected to public lines, a public "turn off" must be installed and maintained by the Applicant at the end of the public line.

**VI. CLASS VI ROADS**

Subdivision on Class VI roads is prohibited.

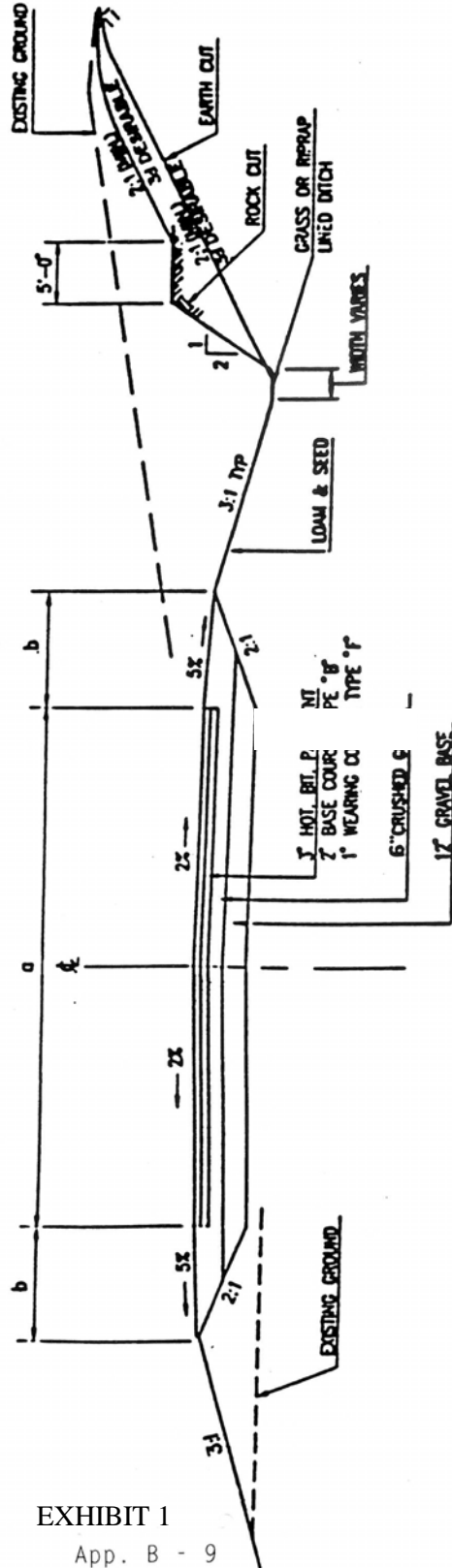

SEE TABLE I FOR a AND b DIMENSIONS  
 a = ROADWAY WIDTH  
 b = SHOULDER WIDTH

**TYPICAL SECTION  
 PAVED ROADS**  
 NOT TO SCALE

EXHIBIT 1  
 App. B - 9

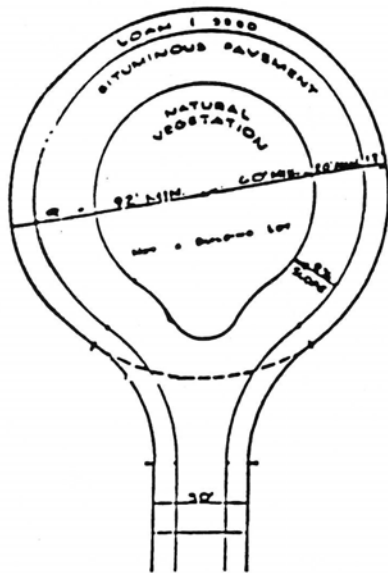

EXHIBIT 2A  
CIRCULAR WITH ISLAND

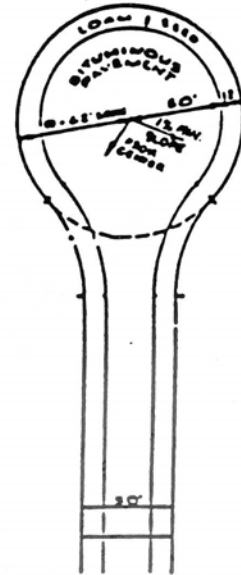
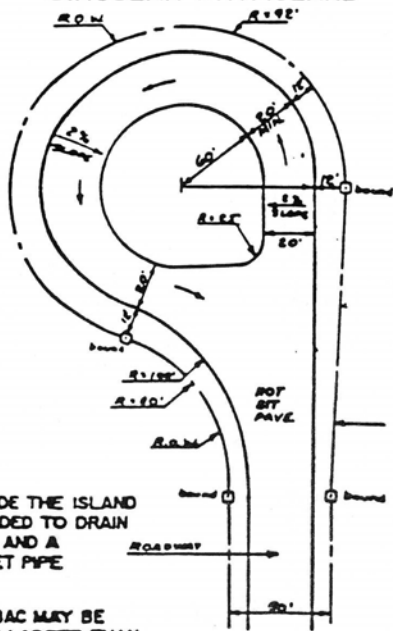

EXHIBIT 2B  
CIRCULAR PAVED



NOTES:

1. THE AREA INSIDE THE ISLAND SHALL BE GRADED TO DRAIN TO THE INSIDE AND A PROPER OUTLET PIPE PROVIDED.
2. THE CUL-DE-SAC MAY BE CONSTRUCTED LARGER THAN SHOWN HERE WITH THE APPROVAL OF THE PLANNING BOARD OR ITS AGENT. THE PAVEMENT WIDTHS SHOWN SHALL NOT BE REDUCED

EXHIBIT 2D  
REVERSE "P" DESIGN

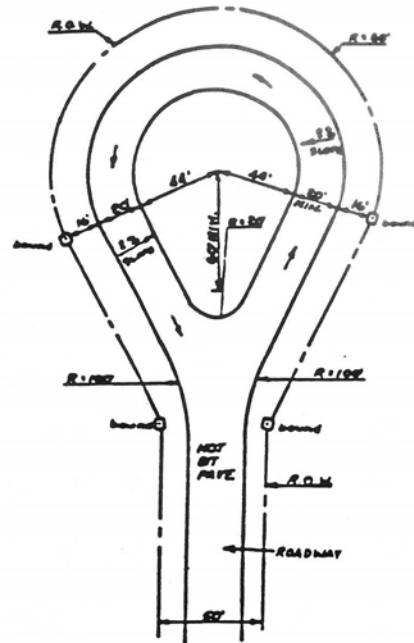
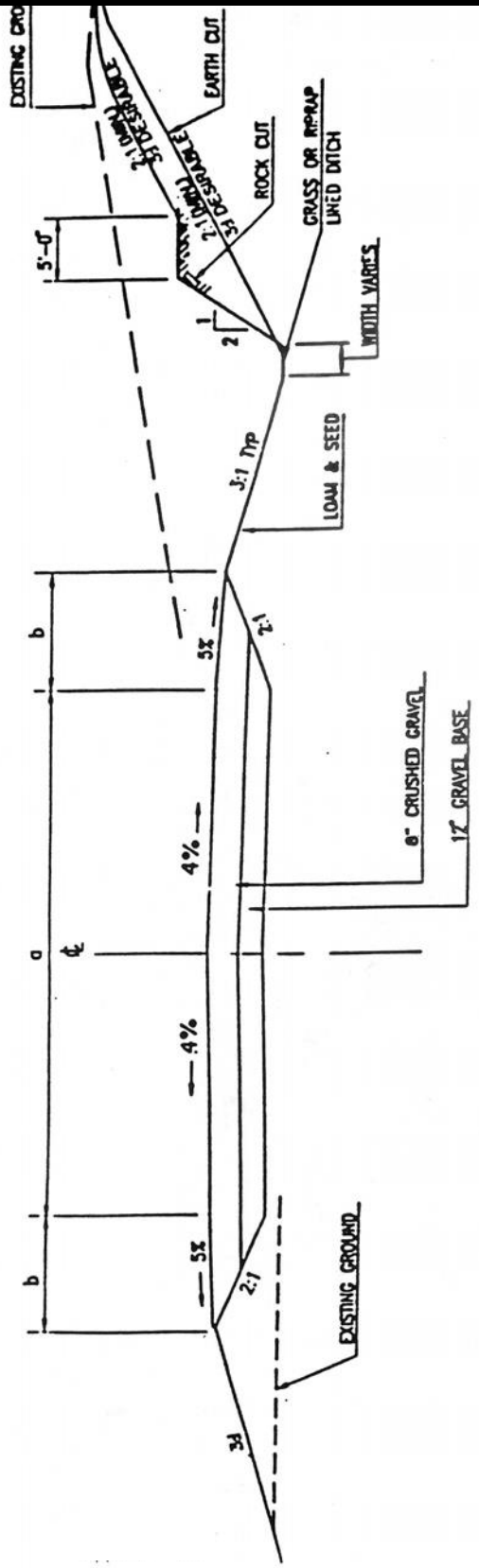

EXHIBIT 2C  
"TEAR DROP" DESIGN

CUL - DE - SAC

1.



SEE TABLE I FOR a AND b DIMENSIONS  
a = ROADWAY WIDTH  
b = SHOULDER WIDTH

### TYPICAL SECTION GRAVEL ROADS

NOT TO SCALE

EXHIBIT 3

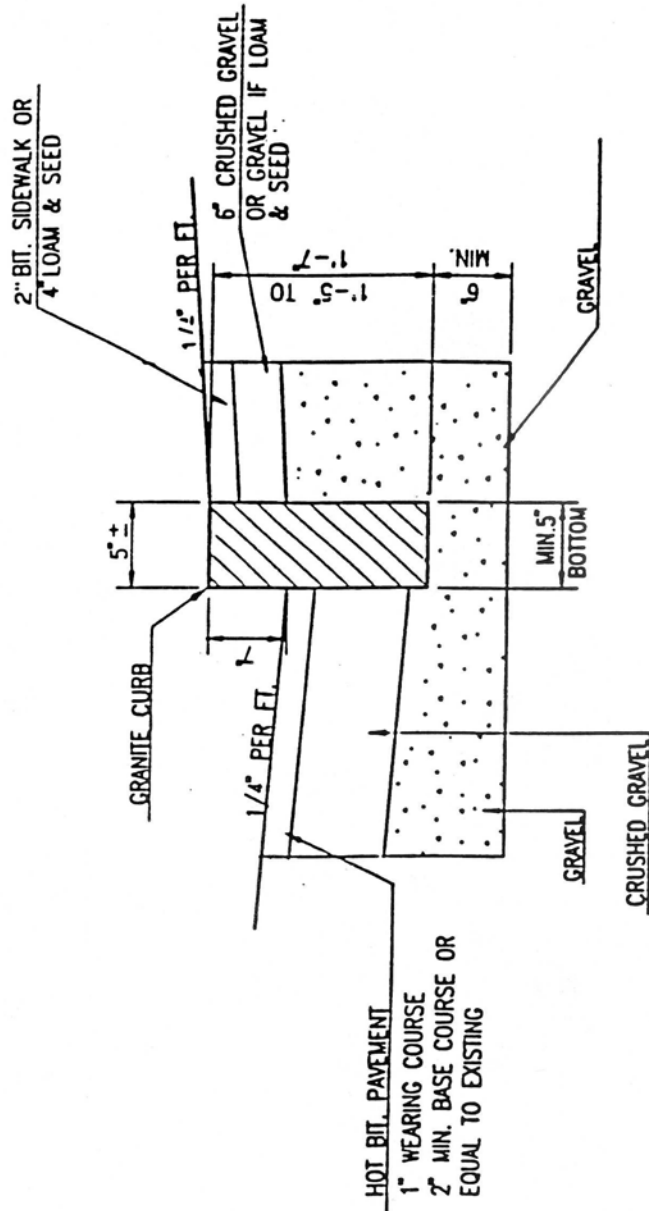

**STRAIGHT - GRANITE CURB**

NOT TO SCALE

EXHIBIT 4

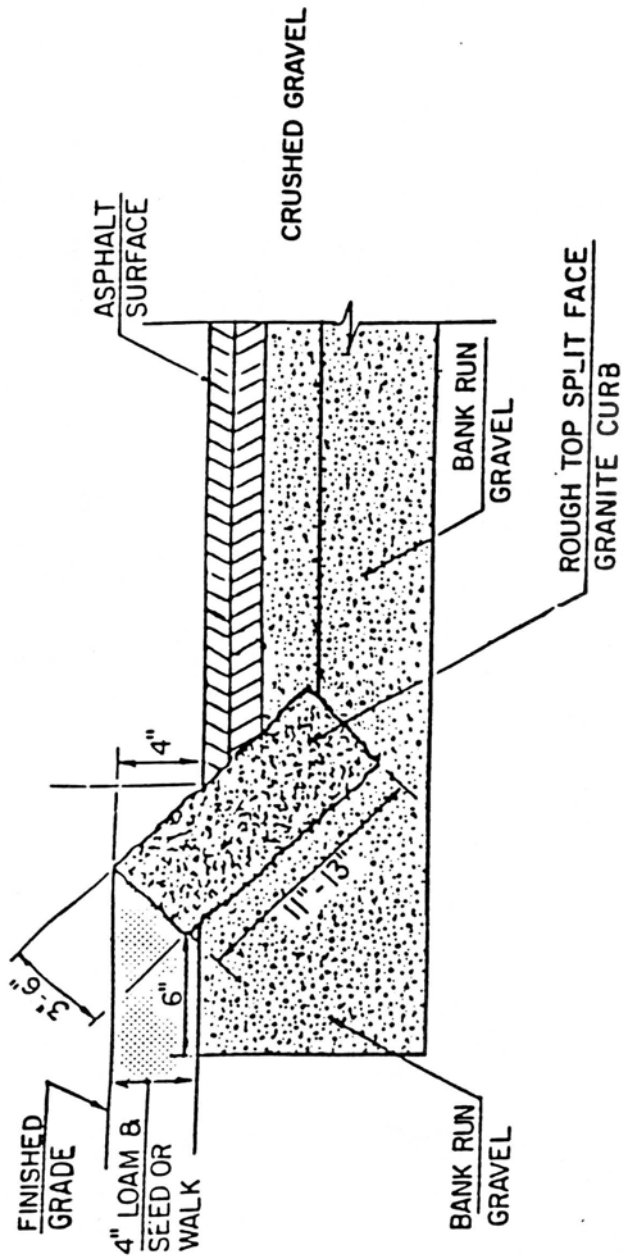

**SLOPED GRANITE CURB**  
 NOT TO SCALE

EXHIBIT 5

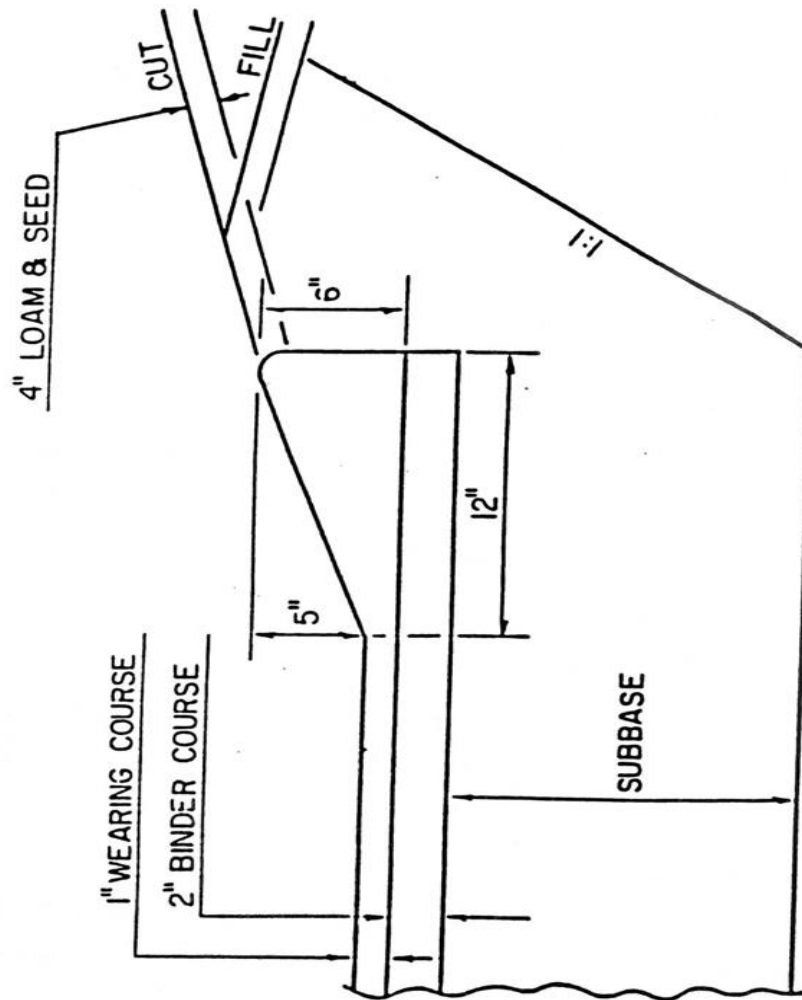

**BITUMINOUS CAPE COD BERM**

NOT TO SCALE

App. B -14

EXHIBIT 6

APP-A12

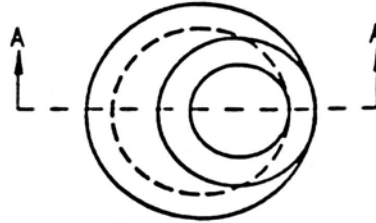

NOTE: MORTARED CONCRETE BLOCK MAY BE USED IN PLACE OF PRECAST CONCRETE. MORTARED CONCRETE BLOCK CATCH BASINS AND MANHOLES SHALL CONFORM TO THE NHDOT STANDARDS.

PLAN

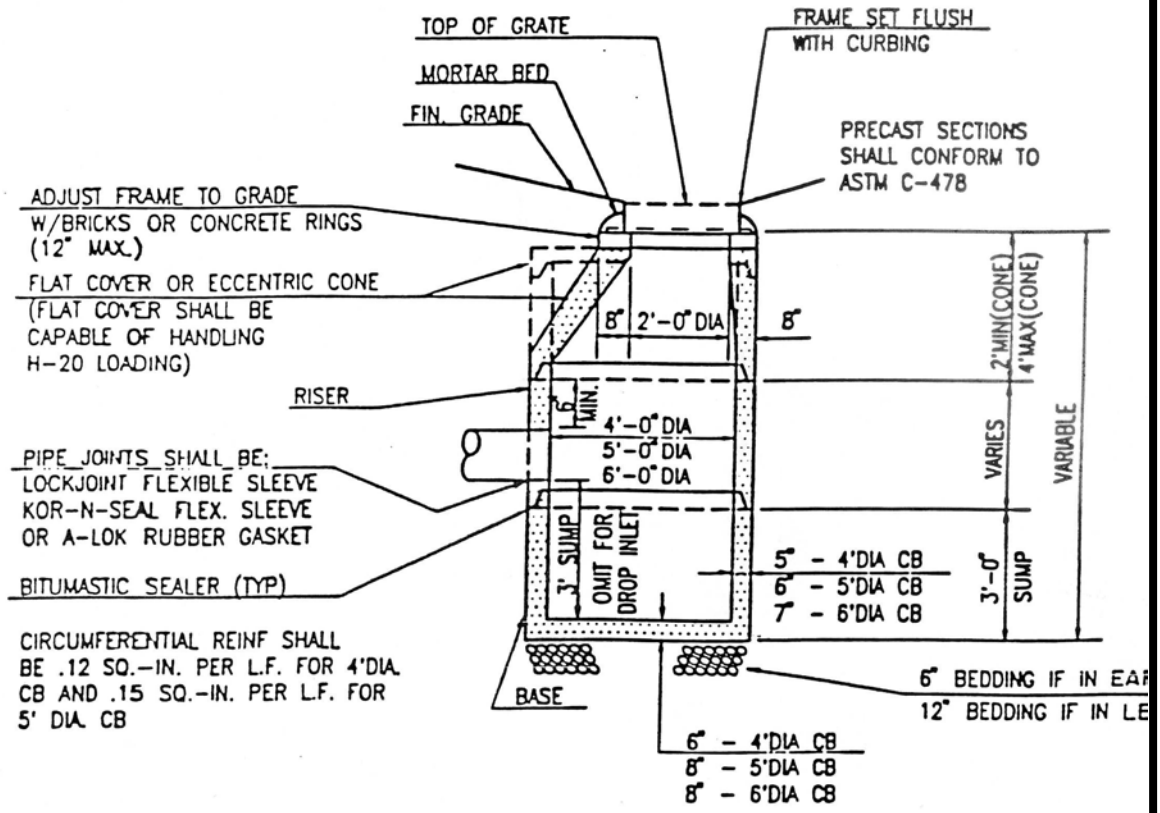

STANDARD CATCH BASIN

NOT TO SCALE

EXHIBIT 7



NOTE: ALTERNATE ECCENTRIC TOP SHALL BE DESIGNED TO MEET OR EXCEED H-20 LOADING

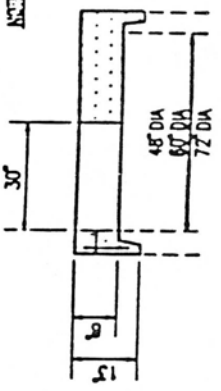

# STANDARD DRAINAGE MANHOLES

NOT TO SCALE

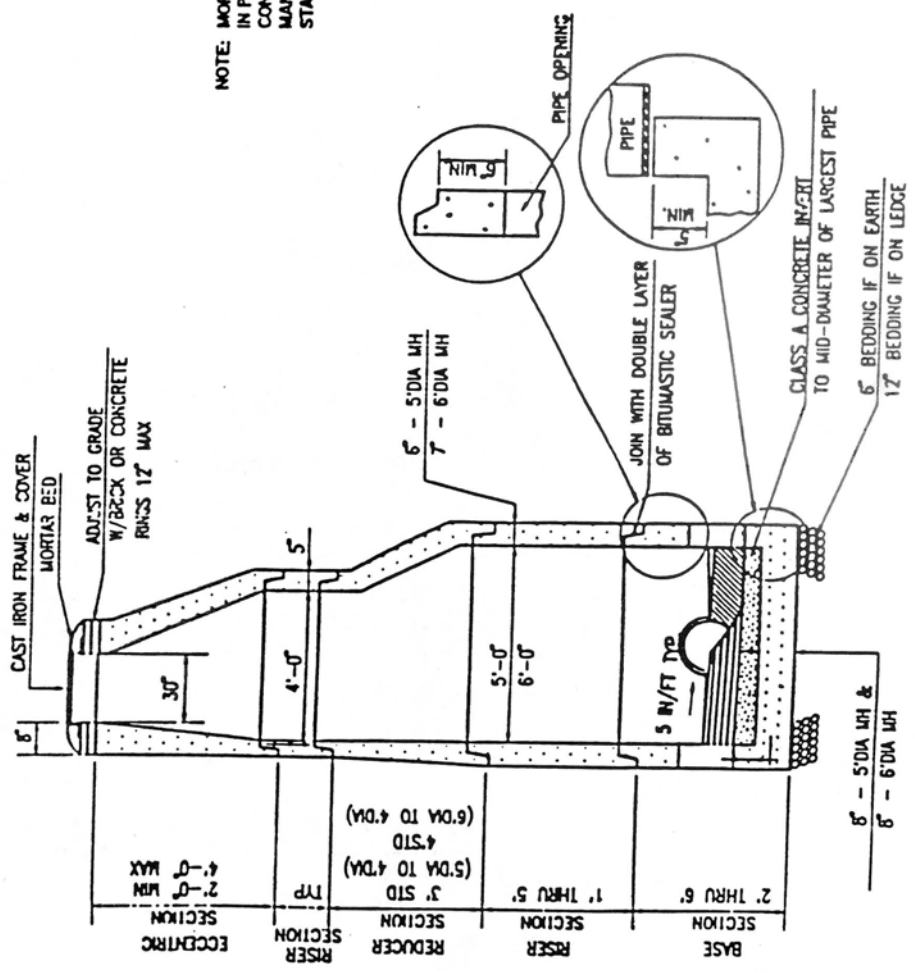

- GENERAL NOTES FOR MHS & CS's**
1. REINF STEEL SHALL CONFORM TO THE LATEST ASTM A185 SPEC  
 4" DIA SECS - 0.12 SQ-IN/LF  
 5" DIA SECS - 0.19 SQ-IN/LF  
 6" DIA SECS - 0.18 SQ-IN/LF  
 8" DIA SECS - 0.24 SQ-IN/LF
  2. CONCRETE SHALL HAVE A COMPRESSIVE STRENGTH OF 4000 PSI MINIMUM
  3. DESIGN SPECIFICATIONS SHALL CONFORM TO ASTM C-478 LATEST EDITION
  4. BASE SECTIONS SHALL BE POURED MONOLITHICALLY

NOTE: MORTARED CONCRETE BLOCK MAY BE USED IN PLACE OF PRECAST CONCRETE. MORTARED CONCRETE BLOCK CATCH BASINS AND MANHOLES SHALL CONFORM TO THE MHDOT STANDARDS

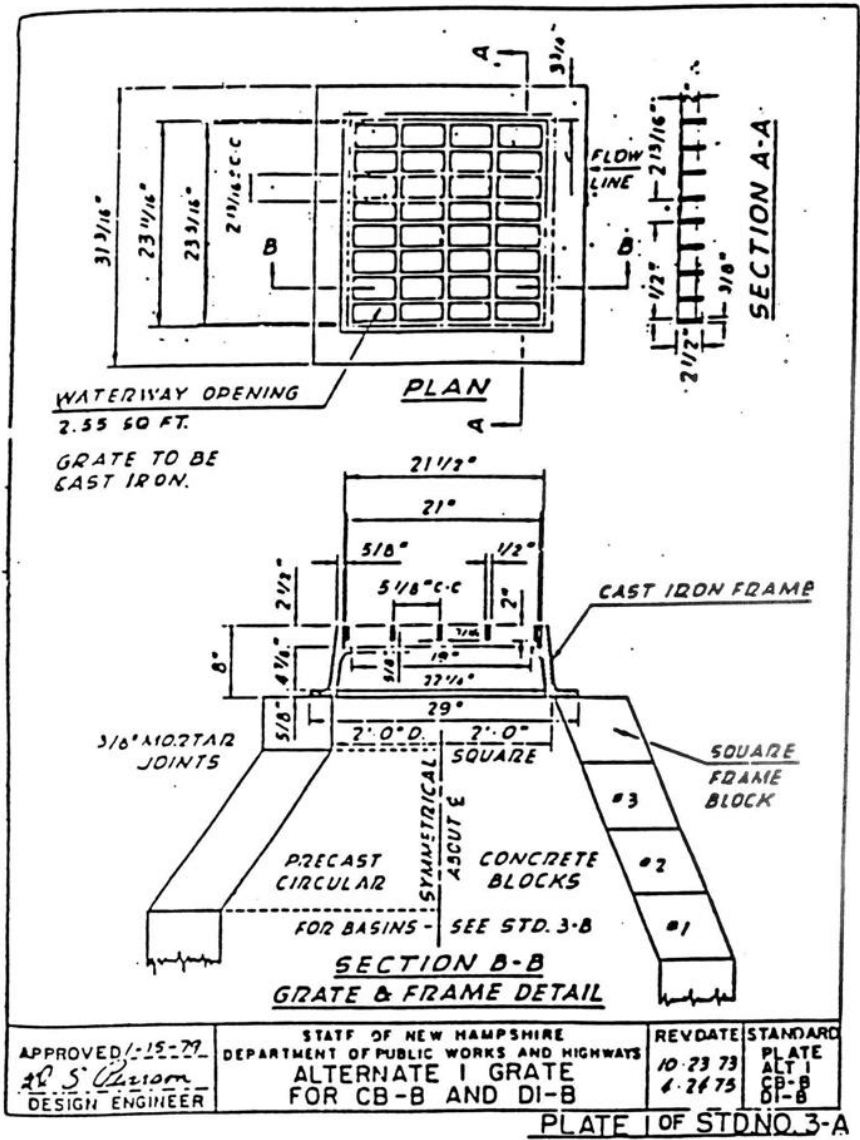

## STANDARD DRAINAGE GRATE & FRAME

App. B - 17

EXHIBIT 9

APP-A15

GROUND SURFACE



PAVED SURFACE

GRAVEL

MARAFI FILTER FABRIC (OR EQUAL)

6" PVC PIPE - PERFORATED

1/2" CRUSHED STONE

6" (TYP.) IF IN EARTH

12" (TYP.) IF IN LEDGE

1'-6" MIN.

6"

6"

### TYPICAL UNDERDRAIN DETAIL

NOT TO SCALE

App. B - 18  
EXHIBIT 10

**APPENDIX B:  
REQUIREMENTS FOR SOILS AND WETLANDS DATA**

**SECTION I: DEFINITIONS**

- **"Average area"** means the total acreage of the property, exclusive of very poorly drained soils, divided by the total number of proposed lots. (Use of average acre here assumes that all lots are roughly the same size.)
- **"Bedrock within 18 inches of the soil surface"** meets the definition of either lithic or paralithic material. At least 75% of delineated areas must meet this definition with no more than 15% of the area having soil properties more limiting (i.e., hydric conditions).
- **"Indurated"** means a rock or soil hardened or consolidated by pressure, cementation, or heat.
- **"Limiting physical features"** means rock outcrops, steep slopes >35%, soils with bedrock within 18 inches of the soil surface, and very poorly drained areas.
- **"Lithic material"** means unaltered material that is continuous, coherent, and indurated. The material qualifies for an "R" designation as a master layer (USDA soil survey Manual, 1993, pg. 121). Plant and tree roots cannot enter except in cracks. Hand digging with a spade is impractical. Some lithic material can be ripped with heavy power equipment. The material must be in a strongly-cemented or more cemented rupture-resistance class. Granite, quartzite, and indurated limestone or sandstone are examples.
- **"Non-limiting"** means the area, exclusive of very poorly drained soils, rock outcrops, bedrock within 18 inches of the soil surface, and soils with steep slopes greater than 35 percent.
- **"Paralithic material"** means a relatively unaltered material that has an extremely weakly cemented to moderately cemented rupture-resistance class. The material qualifies for a "Cr" designation as a subordinate distinction within a master soil layer (USDA soil survey Manual, 1993, pg. 124). Cementation or bulk density are such that plant and tree roots cannot enter except in cracks. The material can be hand dug with a spade with much difficulty. Commonly these materials consist of weathered or weakly consolidated bedrock.
- **"Soil surface"** refers to the top of the first mineral layer.

**SECTION II: REQUIREMENTS FOR SOILS AND WETLANDS DATA IN SUBDIVISION/SITE PLAN  
REVIEW REGULATIONS**

**A. LEVEL 1:**

**Delineation of Wetlands and Surface Waters for all Subdivision/Site  
Plan Review Applications**

Information on wetlands and surface waters shall be provided on the plan with identification and delineation of the resources in accordance with the definitions and standards specified in Step A and B of this section. The written documentation specified in Step C shall be included on the plan and certified by the stamp of a qualified professional.

**Step A: Wetlands Delineations**

Wetlands are to be identified and delineated according to the following standards and/or methodologies:

- Corps of Engineers Wetlands Delineation Manual, Technical Report Y-87-1, Environmental Laboratory, Department of the Army, 1987.
- Field Indicators for Identifying Hydric Soils in New England, Version 2, New England Interstate Water Pollution Control Commission, 1998.
- Chapters Wt 100-800 of the NH Code of Administrative Rules, April 21, 1997.

**Step B: Surface Waters Delineation**

Surface Waters are to be identified and delineated in accordance with RSA 485-A: 2, XIV, NH Water Pollution and Waste Disposal and NH Code of Administrative Rules pursuant to 485-A.

**Step C: Written Documentation**

A written statement shall be included on the subdivision or site plan, certified by the stamp of the Certified Wetland Scientist (CWS) or Permitted Septic Designer (PSD), that all wetlands and surface waters on-site have been delineated in accordance with the standards specified in Steps A and B above.

**B. Additional Information Required Based on the Type of Proposal**

1. If a project proposed for subdivision or site plan review is served by public water and sewer, no additional soils data needs to be submitted for the purpose of determining suitability of the site for subsurface wastewater disposal systems.

Additionally, if the site development calls for structures and/or impervious cover or alteration of an area greater than 100,000 square feet, or 50,000 square feet within the protected shoreland, then the applicant should file a site specific application under NH Code of Administrative Rules Env-Ws 415 and RSA 485-A: 17, significant alteration of terrain. Approval of the permit specified in these rules and statute is required by DES.

2. If the project **meets at least one** of the following three development intensity criteria, then the applicant should submit Site Specific Soil Map (SSS Map) information as specified in subsection D:

- a. The average area is less than two (2) acres in area and is not served by either municipal water or sewer.
  - b. The average area is less than one (1) acre in area and is served by municipal water, but not sewer. Or,
  - c. The non-limiting, upland, contiguous area on any proposed lot is less than 20,000 square feet.
3. For all other projects, the applicant should comply with the data requirements of Level 2.

**C. LEVEL 2:**

**Confirmation of County Soil Survey Maps and Identification of Limiting Physical Features**

**Step A: Identification of Soil Complexes with Dramatically Different Characteristics**

- If any of the soil map units on the property, as mapped by the NRCS county soil survey, is a complex of soils with dramatically different characteristics that would have an impact on use and management of the property, then the applicant must provide SSSMS information as required in Level 3.
- If the soils mapped by the NRCS county soil survey do not include one of these complexes, continue to Step B.

**Step B: Confirmation of NRCS County Soil Survey Map**

The following information is required to be submitted for confirmation of the NRCS county soil survey:

1. A copy of the NRCS county soil survey with the subdivision or site plan location and approximate boundaries superimposed on the soil map. The copy of the county soil survey must be provided at the same scale as the original county soil survey. This is important, so that the limitations of the information provided at the scale of the survey are not misunderstood by the users.
2. A representative number of detailed soil profile descriptions to characterize variations in the landscape for each mapped unit, based on NRCS standards as described in the Field Book for Describing and Sampling Soils; Version 1.1 National Soil Survey Center, NRCS, 1998. These profile descriptions are to be included in a narrative report for the project.

The applicant is required to evaluate and submit detailed soil profile descriptions to document that the conditions on site are adequate to support the proposed use and management of the property. The standards and/or methodologies for doing this are listed below. These sources should be cited directly on the plan.

If the proposal meets the requirements of Step B, then Level 2 information is potentially adequate for local review, provided that the NRCS soil

survey information is determined to be sufficient for the proposed use and management of the property.

### **Standards**

The required tasks under Level 2 are to be carried out according to the standards found in the following documents:

- Field Book for Describing and Sampling Soils: Version 1.1 National Soil Survey Center, NRCS, 1998.
- Keys to Soil Taxonomy, Eighth Edition, USDA/NRCS 1998.
- NRCS Official Series Description Sheets and/or published map unit descriptions, USDA/NRCS.

### **Methods**

A minimum of one soil profile description shall be completed per soil map unit within the plan area, as depicted on the NRCS county soil survey. The soil will be described in sufficient detail, so as to support or refute that identified properties are within, or similar to those of the soil series used to name the map unit.

Soils descriptions should be carried out in areas suspected of having the greatest likelihood of contrasting soil features. Some map units will require more than one soil description to document soil variability. The map unit purity standards from Site Specific Soil Mapping Standards for New Hampshire and Vermont, Version 2.0, Society of Soil Scientists of Northern New England Publication No. 3, 1999, will apply.

- The location(s) of the soil profile description(s) used to corroborate the NRCS soil series shall be shown on the plan, with a reference to the description(s) in the narrative report for the project.
- A detailed comparison between each soil profile description and the representative pedon (a description of a small three-dimensional area of soil that is typical of the soil series in the county) for that soil from the county soil survey shall be included in the detailed narrative for the project. The NRCS Official series Description Sheets and/or NRCS published map unit descriptions for each mapped unit are to be used as references.
- A written statement that the soil profile description(s) from the site adequately reflect the range of characteristics for the series, as described in the county soil survey. The statement shall indicate that the county soil survey adequately represents soil and landscape characteristics, such that site specific land use decisions can be made without further soil investigations. This statement is to be certified by the stamp of the CSS or PSD. If this statement cannot be made, proceed to Level 3.

- A narrative report for the project which summarizes the information compiled in Step B. This shall include a determination of whether limiting physical features are present on the parcel and indicate the specific mapped soil units where these occur. If any limiting physical features are identified on-site, then Step C is required.
- If the on-site investigations confirm the nature and properties of the soils as reflected by the soil map, consistent with the intended use and intensity of development, as Level 2 review is potentially adequate for the Planning Board's purposes. However, the Planning Board may, at its discretion, require submission of on-site soils data.

**Step C: Identification of Limiting Physical Features**

In addition to the information required in Steps A and B, the information specified below is required for identification and documentation of limiting physical features. This can either be done as a stand-alone document or as an amendment or addendum to the narrative prepared under Step B.

- Delineation of the limiting features, specifically rock outcrops, steep slopes >35%, soils with bedrock within 18 inches of the soil surface, and very poorly drained areas on-site. These features are to be shown on the plan.
- A detailed description of each limiting physical feature, based on NRCS standards, in a narrative report for the project, with reference to its location on the plan. This can either be done as a stand-alone document or as an amendment or addendum to the narrative prepared under Step B.
- A written statement that the limiting physical features identified above would not have a significant impact on use and management of the property. This statement is to be certified by the stamp of the CSS or PSD. If this statement cannot be made, then proceed to Level 3.
- A written statement that limiting physical features are present on the parcel(s) and that either (1) a SSS Map (Level 3) is required, or (2) not required, with supporting documentation for this position. This determination is to be certified by the stamp of the CSS or PSD. If a SSS Map is required, then proceed to Level 3.

**D. Level 3:**

Site Specific Soil (SSS) Map for Intense Development and for Sites with Limiting Features

If required, an applicant shall submit a site specific soil map prepared in accordance with Site Specific Soil Mapping Standards for New Hampshire and Vermont Version 2.0, Society of Soil Scientists of Northern New England Publication No. 3, 1999. This is to be certified by the stamp of the CSS.



**APPENDIX C:**  
**SAMPLE FORMS AND PUBLIC NOTIFICATIONS**

1. **SUBMISSION OF APPLICATION** (used only for submission - not public hearing)

**Town of Roxbury**  
**LEGAL/PUBLIC NOTICE**

Notice is hereby given in accordance with RSA 676:4 that an application for (Subdivision/Site Plan Review - Description of Application; Name of Applicant; Location of Property; Tax Map and Lot Number) will be submitted to the Planning Board on (DATE) at (TIME) at the Roxbury Town Hall during a regular meeting of the Board. Upon a finding by the Board that the application meets the submission requirements of the Roxbury (Subdivision/Site Plan Review Regulations), the Board will vote to accept the application as complete and schedule a public hearing. Should the application not be accepted as complete, another submission meeting will be scheduled. Anyone needing assistance to attend this meeting should contact the Selectmen's Office one week prior to the scheduled date.

Per order of the Roxbury Planning Board  
\_\_\_\_\_, Secretary/Clerk

2. **SUBMISSION OF APPLICATION/PUBLIC HEARING ON PROPOSAL** (for Expedited Review)

**Town of Roxbury**  
**LEGAL/PUBLIC NOTICE**

Notice is hereby given in accordance with RSA 676:4 & 675:7 that an application for (Subdivision/Site Plan Review - Description of Application; Name of Applicant; Location of Property; Tax Map and Lot Number) will be submitted to the Planning Board on (DATE) at (TIME) at the Roxbury Town Hall during a regular meeting of the Board. Upon a finding by the Board that the application meets the submission requirements of the Roxbury (Subdivision/Site Plan Review Regulations), the Board will vote to accept the application as complete, and a public hearing on the merits of the proposal will follow immediately. Should a decision not be reached at the public hearing, this application will stay on the Planning Board agenda until such time as it is either approved or disapproved. Anyone needing assistance to attend this meeting should contact the Selectmen's Office one week prior to the scheduled date.

Per order of the Roxbury Planning Board  
\_\_\_\_\_, Secretary/Clerk

**3. PUBLIC HEARING ON PROPOSAL**

**Town of Roxbury  
LEGAL/PUBLIC NOTICE**

Notice is hereby given in accordance with RSA 676:4 & 675:7 that the Roxbury Planning Board will hold a public hearing for (Subdivision/Site Plan Review - Description of Application; Name of Applicant; Location of Property; Tax Map and Lot Number) on (DATE) at (TIME) at the Roxbury Town Hall. Should a decision not be reached at the public hearing, this application will stay on the Planning Board agenda until such time as it is either approved or disapproved. Anyone needing assistance to attend this meeting should contact the Selectmen's Office one week prior to the scheduled date.

Per order of the Roxbury Planning Board  
\_\_\_\_\_, Secretary/Clerk

**4. ABUTTER NOTICES FOR SUBDIVISION OR SITE PLAN REVIEW APPLICATION**

Dear \_\_\_\_\_,

According to NH Revised Statutes Annotated 676:4,I (d) and the Town of Roxbury (Subdivision/Site Plan Review), it is required that all abutters to land intended for (subdivision/site plan review) be notified of the proposal.

You, as an abutter, are hereby notified that an application for (Subdivision/Site Plan Review - Description of Application; Name of Applicant; Location of Property; Tax Map and Lot Number) will be submitted to the Planning Board on (DATE) at (TIME) at the Roxbury Town Hall during a regular meeting of the Board. Upon a finding by the Board that the application meets the submission requirements of the Roxbury (Subdivision/Site Plan Review Regulations), the Board will vote to accept the application as complete, and a public hearing on the merits of the proposal will follow immediately.

Should a decision not be reached at the public hearing, this application will stay on the Planning Board agenda until such time as it is either approved or disapproved.

Please be advised that, as an abutter, your right to testify is restricted to the public hearing. In the case of a public *meeting*, as opposed to a public *hearing*, you are allowed by right to be notified and be present, but you do not have the right to offer testimony except at the Planning Board's discretion.

Sincerely,

Planning Board Secretary/Clerk

**5. APPLICANT NOTICE FOR SUBDIVISION OR SITE PLAN REVIEW**

Dear \_\_\_\_\_,

According to NH Revised Statutes Annotated 676:4,I (d) and the Town of Roxbury(Subdivision/Site Plan Review Regulations), it is required that all applicants for land development be sent notice of the public meeting and public hearing at which their proposal will be submitted to the Board and reviewed.

You, as the applicant, are hereby notified that your application for (Subdivision/Site Plan Review - Description of Application; Location of Property; Tax Map and Lot Number) will be submitted to the Planning Board on (DATE) at (TIME) at the Roxbury Town Hall during a regular meeting of the Board. Upon a finding by the Board that the application meets the submission requirements of the Roxbury (Subdivision/Site Plan Review Regulations), the Board will vote to accept the application as complete, and a public hearing on the merits of the proposal will follow immediately.

Should a decision not be reached at the public hearing, this application will stay on the Planning Board agenda until such time as it is either approved or disapproved. Should your application be disapproved, you will receive written notice from the Planning Board within 144 hours stating the reasons for such disapproval.

Sincerely,

Planning Board Secretary/Clerk

**6. SURVEYOR NOTICE FOR SUBDIVISION OR SITE PLAN REVIEW**

According to NH Revised Statutes Annotated 676:4,I (d) and the Town of Roxbury (Subdivision/Site Plan Review Regulations), it is required that any persons who have prepared plans for approval be notified of the submission and hearing on the application.

You are hereby notified that an application prepared by you for a (Subdivision/Site Plan Review - Description of Application; Location of Property; Tax Map and Lot Number) will be submitted to the Planning Board on (DATE, TIME, PLACE) during a regular meeting of the Board.

Upon a finding by the Board that the application meets the submission requirements of the Roxbury (Subdivision/Site Plan Review Regulations), the Board will vote to accept the application as complete, and a public hearing on the merits of the proposal will follow immediately. Should a decision not be reached following the public hearing, this application will stay on the Planning Board agenda until such time as it is either approved or disapproved.

Should this application be disapproved, the applicant will receive written notice from the Planning Board within 144 hours stating the reasons for disapproval, and advising the applicant of what corrective measures would be needed.

Per order of \_\_\_\_\_, Chairman  
Roxbury Planning Board

**7. APPLICATION FOR WAIVER OF SUBDIVISION/SITE PLAN REVIEW REQUIREMENT**

Date: \_\_\_\_\_

To the Chairman and Members of the Roxbury Planning Board:

On (DATE) I submitted a plan for (subdivision/site plan review) approval to the Board, entitled \_\_\_\_\_ and prepared by \_\_\_\_\_. Pursuant to Section X of the Board's regulations, I am requesting a waiver from the following items for reasons stated below:

1. \_\_\_\_\_  
\_\_\_\_\_
2. \_\_\_\_\_  
\_\_\_\_\_
3. \_\_\_\_\_  
\_\_\_\_\_
4. \_\_\_\_\_  
\_\_\_\_\_

Respectfully submitted,

\_\_\_\_\_

**8. NOTICE OF PLANNING BOARD DECISION**

*[Once the Planning Board has held the public hearing and voted on the application, the final decision must be put in written form and placed on file in the Town offices and made available to the public within 144 hours. The Board is not required to notify the applicant individually except in the case of a denial, in which case the same time limit applies.]*

**NOTICE OF PLANNING BOARD APPROVAL**

On \_\_\_\_\_, 20\_\_, after duly-noticed public hearing(s), the Planning Board voted to **APPROVE** the Plan for (a X-lot subdivision) submitted to the Board by \_\_\_\_\_ for property located at (Street Address, Tax Map & Lot Number and Zoning District). Any conditions to which the plan is subject are listed below:

1. \_\_\_\_\_
2. \_\_\_\_\_
3. \_\_\_\_\_
4. \_\_\_\_\_
5. \_\_\_\_\_

\_\_\_\_\_, Planning Board Chair

**NOTICE OF PLANNING BOARD DENIAL**

On (DATE) after duly-noticed public hearing(s), the Planning Board voted to DENY the Plan for (\_\_\_\_\_) submitted to the Board by \_\_\_\_\_ for property located at (Street Address, Tax Map & Lot Number and Zoning District). The application was denied for the following reasons:

- 1. \_\_\_\_\_
- 2. \_\_\_\_\_
- 3. \_\_\_\_\_
- 4. \_\_\_\_\_
- 5. \_\_\_\_\_

\_\_\_\_\_, Planning Board Chair

**9. NOTICE OF PUBLIC HEARING TO REVOKE PLANNING BOARD APPROVAL**

**Town of Roxbury  
LEGAL/PUBLIC NOTICE**

Notice is hereby given in accordance with RSA 676:4-a the Planning Board will hold a public hearing on (DATE) at (TIME) at the Roxbury Town Hall for the purpose of considering whether to revoke a plan previously-approved on \_\_\_\_\_, 20\_\_ and filed with the Cheshire County Register of Deeds. The Board is considering revocation for the reasons stated below. Should a decision not be reached at the public hearing, this application will stay on the Planning Board agenda until such time as it is either approved or disapproved.

Per order of the \_\_\_\_\_ Planning Board  
\_\_\_\_\_, Secretary/Clerk

**10. DECLARATION OF REVOCATION**

*[Once the Board has voted to revoke a previously-approved plan, a declaration of revocation must be filed with the county register of deeds no sooner than 30 days after written notification to the applicant, or 30 days after the public hearing, whichever is later. The declaration must be recorded under the same name as that on the original approval, dated, endorsed in writing by the Planning Board, and contain reference to the recording information of the plan being revoked.]*

Notice is hereby given that the Roxbury Planning Board voted on (DATE) to revoke the approval of (Plan Name) granted to (Applicant Name) on (DATE). The Plan was recorded in the Cheshire County Register of Deeds as Plan \_\_\_\_\_ and filed on (DATE). The approval was revoked for the following reasons:

- \_\_\_\_\_
- \_\_\_\_\_
- \_\_\_\_\_

Respectfully Submitted,

\_\_\_\_\_  
Planning Board Chair

11. ADOPTION OR AMENDMENTS TO SUBDIVISION OR SITE PLAN REVIEW REGULATIONS

**Town of Roxbury  
NOTICE OF PUBLIC HEARING**

Pursuant to RSA 675:6 & 7, the Planning Board will hold a public hearing on (DATE) (TIME) at the Roxbury Town Hall on a (proposed amendment or the adoption of the Subdivision or Site Plan Review) Regulation. The effect of the (proposed amendment or adoption) will be to:

*(Here insert a topical description of the proposed changes)*

A full copy of the text of the proposed amendment is available for review in the Town Clerk's office during regular business hours.

Per order of the \_\_\_\_\_ Planning Board  
\_\_\_\_\_, Secretary/Clerk

**APPENDIX D:**  
**CRITERIA FOR DETERMINING REGIONAL IMPACT**

Impact Criteria shall include, but not be limited to, the following items. These shall in no way be considered exhaustive, but rather guidelines for the Board to follow in making a determination of impact on a neighboring municipality.

- A. RESIDENTIAL DEVELOPMENT:** Proposals for lots or dwellings that would increase the existing housing stock of the town by more than 25%.
  
- B. COMMERCIAL DEVELOPMENT:** Proposals for new or expanded space of 50,000 square feet or greater.
  
- C. INDUSTRIAL DEVELOPMENT:** Proposals for new or expanded space of 100,000 square feet or greater.
  
- D. OTHER FACTORS TO BE CONSIDERED:**
  - 1. Proximity to other municipal boundaries.
  - 2. Traffic impacts on the regional road network.
  - 3. Potential effect on groundwater, surface water and wetlands that transcend municipal boundaries.
  - 4. The potential to disturb or destroy a significant or important natural environment or habitat.
  - 5. The necessity for shared public facilities such as schools or solid waste disposal.
  - 6. Anticipated emissions such as light, noise, smoke, odors, or particulates.
  - 7. The potential for accidents that would require evacuation of a large area.
  - 8. The generation and/or use of any hazardous materials.

**APPENDIX E:  
PROCEDURE FOR APPLICATION REVIEW**

**I. PREAPPLICATION REVIEW - OPTIONAL**

The two stages of preapplication review are optional at the request of the applicant. The applicant may choose to engage in both the Preliminary Conceptual Consultation and the Design Review Phase, or anyone of the two.

**A. PRELIMINARY CONCEPTUAL CONSULTATION**

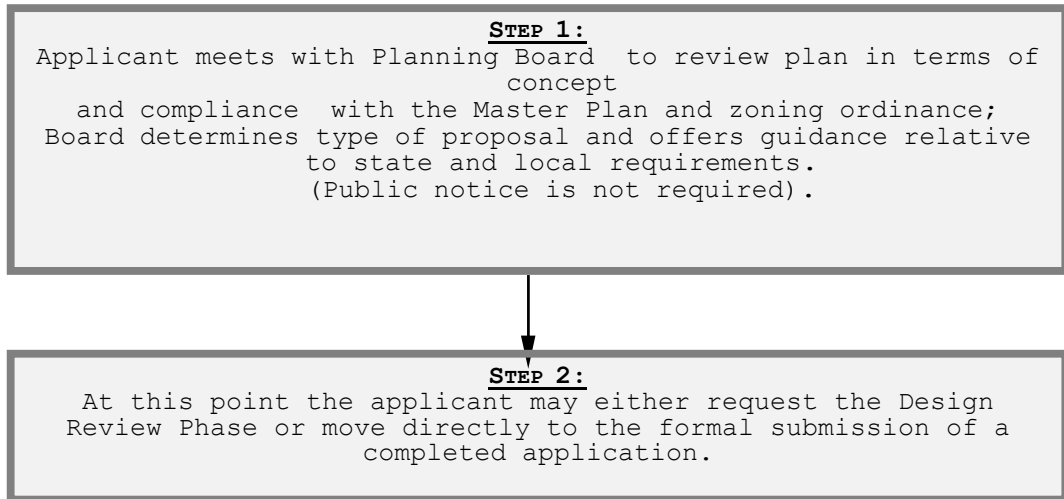

**B. DESIGN REVIEW PHASE**

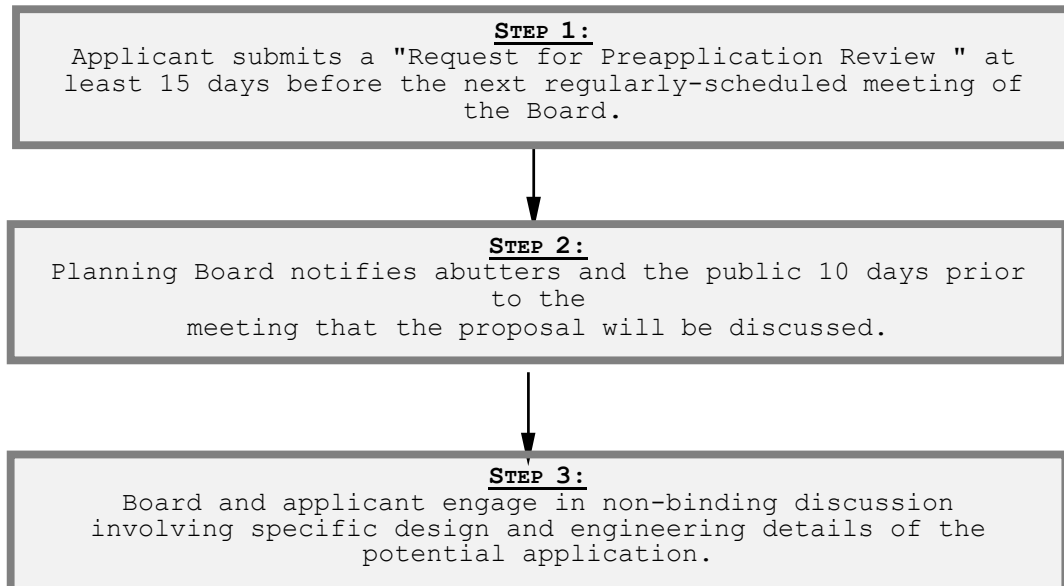



## II. APPLICATION PROCEDURE

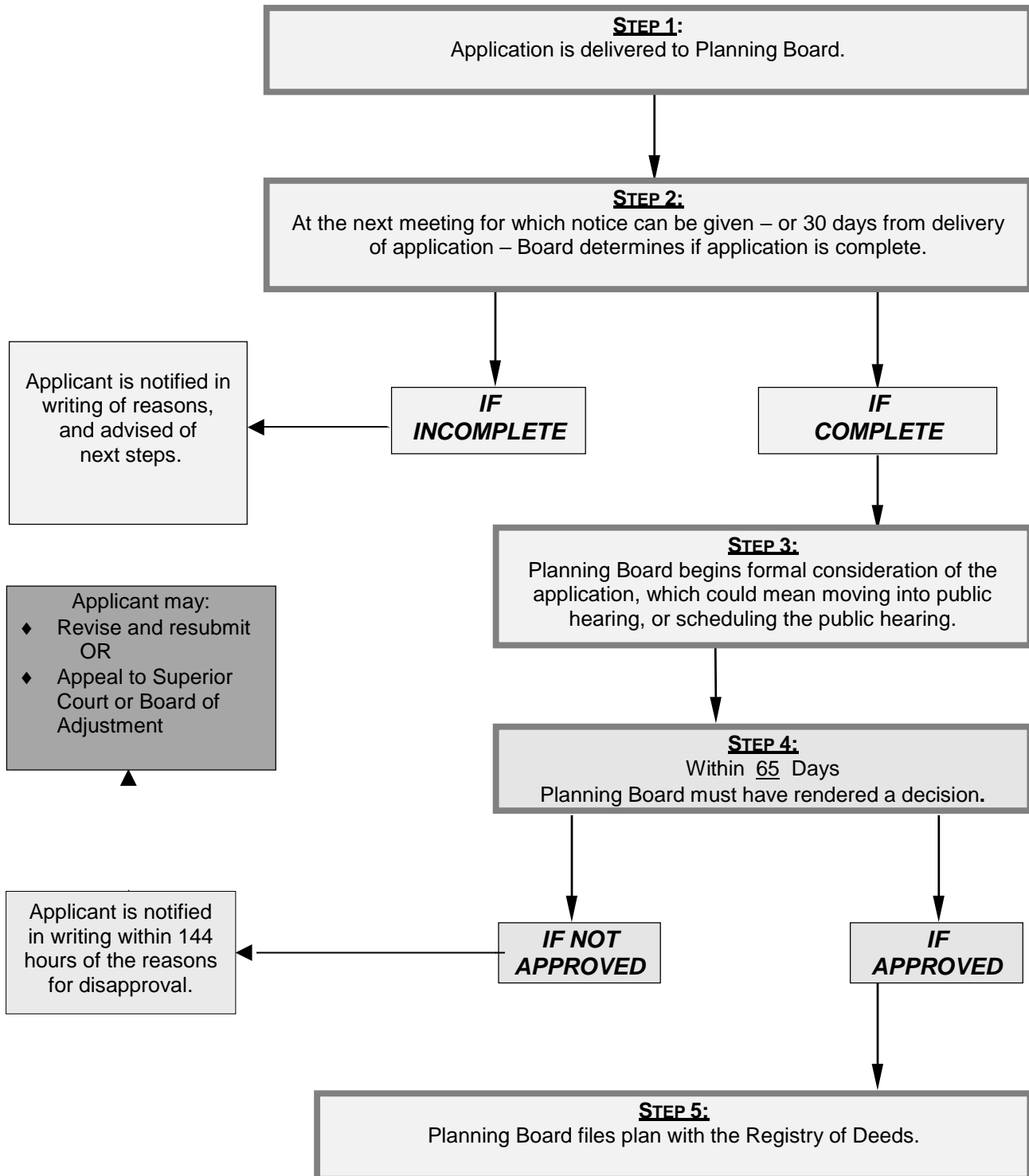

**NOTE:** For a technical subdivision, the public hearing may take place on the same evening as the vote to accept the plan as complete, provided the notice has advised of the possibility.