

JAY•LOR®

Cutter • Mixer • Feeder

PARTS BOOK

MODELS 2300/2350



"Putting the 'Total' into TMR"

JAY-LOR® Fabricating Inc.
RR # 2 Orton, Ontario, Canada, L0N 1N0 Tel: (519) 787-9353 Fax: (519) 787-7053

163-05-01

JAY•LOR®

Cutter • Mixer • Feeder

PARTS BOOK

Effective: December 1, 2000

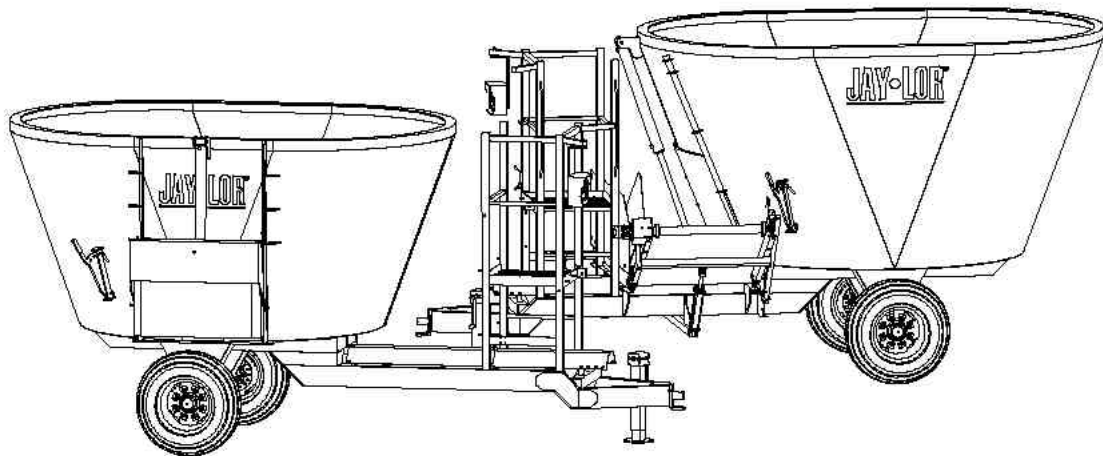

MODELS 2300/2350

"Putting the 'Total' into TMR"

JAY-LOR® Fabricating Inc.
RR # 2 Orton, Ontario, Canada, L0N 1N0 Tel: (519) 787-9353 Fax: (519) 787-7053

163-05-01

FOREWORD

This Dealer Copy of the Parts Book contains common and general information applicable to the JAY•LOR® Models 2300 and 2350 Cutter-Mixer-Feeders. It has been carefully designed to ensure that correct and accurate information is portrayed in every area of a typical unit, enabling efficient and effective service to the end user of JAY•LOR® Fabricating Inc.'s products.

The format of this book consists of a fundamental breakdown of components and assemblies according to the area in which they are located or function on the machine. Each area or section contains illustrative information regarding a part or an assembly, along with information such as part numbers and quantities included. At the end of each section a Price List is found containing Dealer and Suggested List prices for the most common service items pertaining to that section. For details and pricing information regarding parts and assemblies depicted in the illustrations but not included in the price lists, please contact JAY•LOR® Fabricating Inc. Our service personnel will be more than willing to assist you in obtaining information as it pertains to JAY•LOR® Fabricating Inc.'s line of products. Information and pricing for non-stock and/or custom items will be quoted on request.

Note:

Parts and assemblies in this book may not be exactly as shown. JAY•LOR® Fabricating Inc. reserves the right to make any changes/revisions/amendments at any time as deemed necessary to ensure that correct information is provided.

Price Lists are prepared for the most common parts and assemblies only, and are subject to change at any time, without notice. JAY•LOR® Fabricating Inc. will do its utmost to provide the latest information regarding our products. To ensure that the most recent information is available, please contact JAY•LOR® Fabricating Inc. **All prices in effect as of the date specified on the cover page of this book.**

Contact us at:

JAY•LOR®
Fabricating Inc

**R.R.#2
Orton, ON
Canada
L0N 1N0**

Phone: (519) 787-9353
Toll-Free: (800) 809-8224
Fax: (519) 787-7053
e-mail: jaylor@jaylor.com
on the web: www.jaylor.com

GENERAL INFORMATION

The JAY•LOR® Models 2300 and 2350 are a new model series that replace the JAY•LOR® Models 1300 and 1350. While several new features are found in the new JAY•LOR® Models 2300 and 2350, many areas of this book may apply to the JAY•LOR® Models 1300 and 1350. For information and assistance regarding differences between the old and new model series, please contact JAY•LOR® Fabricating Inc.

It is important to use extreme caution when performing any type of service to this equipment. General information regarding service procedures and intervals is covered in the Operator's Manual provided with the new product. For more specific product service, please contact JAY•LOR® Fabricating Inc. to obtain Technical Service Bulletins that outline the procedures and requirements for such. Please note that additional copies or replacements for any of this documentation can be ordered through JAY•LOR® Fabricating Inc.

It is also important to ensure that only JAY•LOR® genuine or approved parts are to be used where applicable. Mismatched or incorrect components can result in machine damage or malfunction, or possibly personal injury.

PART NUMBERING SYSTEM

JAY•LOR® Fabricating Inc. uses a 7-digit Part Numbering System for identification of parts and assemblies used in the products we manufacture. Please refer to the machine diagram at the end of this section for details on how numbers are applied according to the area of the machine in which they are found.

ORDERING INFORMATION

Ordering components for JAY•LOR® products is simple. We ask that you complete a Parts Order Form, a copy of which is attached with this book. If unclear about any of the parts or assemblies found throughout this book, please contact JAY•LOR® Fabricating Inc.

It is important to include the machine model and serial numbers when ordering parts if applicable. The serial number plate is located on the frame of the machine as indicated in the diagram below:

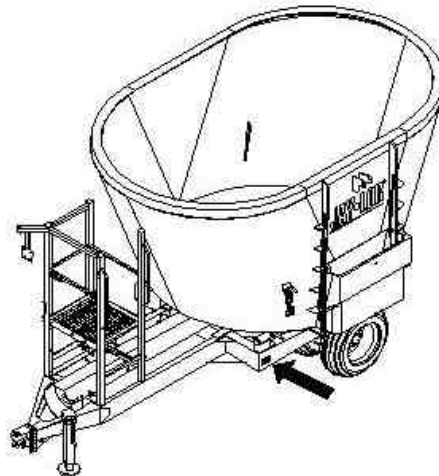

In order to ship your order correctly and promptly be sure to state clearly the part numbers and descriptions. Shipping instructions, including any special routing should be given. If you make reference to a previous shipment, please refer to the invoice number and date.

JAY·LOR[®] Fabricating Inc. will only process Parts Orders that have been received via facsimile or e-mail.

INVOICING TERMS AND CONDITIONS

Pricing:

For parts or assemblies sold and not associated with the sale of a JAY•LOR[®] mixer, prices as per Parts Book will be used (Dealer or Suggested List).

For parts or assemblies sold as extra parts or options (i.e. not listed in the JAY•LOR[®] Fabricating Inc. Sales Book), prices as per Parts Book will be used (Dealer or Suggested List).

Terms:

Net 30 Days, FOB JAY•LOR[®] Fabricating Inc. applies to accounts in good standing. Overdue accounts will be charged 2% per month. All goods remain property of JAY•LOR[®] Fabricating Inc. until paid in full.

WARRANTY

On Goods Ordered:

Our guarantee of products made or sold by us is limited to an agreement to repair or replacement without charge any item found defective in workmanship or material upon receipt. No claims will be allowed for labour or consequent damages.

Any part, assembly, component, etc. that has been installed and/or replaced according to specifications established by JAY•LOR[®] Fabricating Inc. will be warranted under the JAY•LOR[®] Fabricating Inc. Limited Warranty (Machine). Please refer to the procedures set out with this documentation for details on warranty coverage.

JAY·LOR[®] Fabricating Inc. Limited Warranty (Machine):

If parts and/or assemblies are ordered under the terms of JAY•LOR[®] Fabricating Inc.'s Limited Warranty (as applied to the machine with date of purchase), please follow the procedures set out with this documentation to process a claim.

EXCHANGED/RETURNED GOODS

Do not return any goods without first obtaining our permission. Whenever possible, JAY•LOR® Fabricating Inc. will accommodate customers by accepting returns provided that products have not been used or damaged. Please contact JAY•LOR® Fabricating Inc. to obtain a Return Goods Acquisition Number (RGA #).

Please note that any extra shipping, brokerage, and handling charges incurred are the responsibility of the customer.

Returned Goods - Unused:

The price paid for goods upon return to JAY•LOR® Fabricating Inc. will be credited the price paid less 20%.

Returned Goods – Used:

The return of used goods is normally not accepted by JAY•LOR® Fabricating Inc. Individual cases may be approved upon decision by the JAY•LOR® Warranty Administrator.

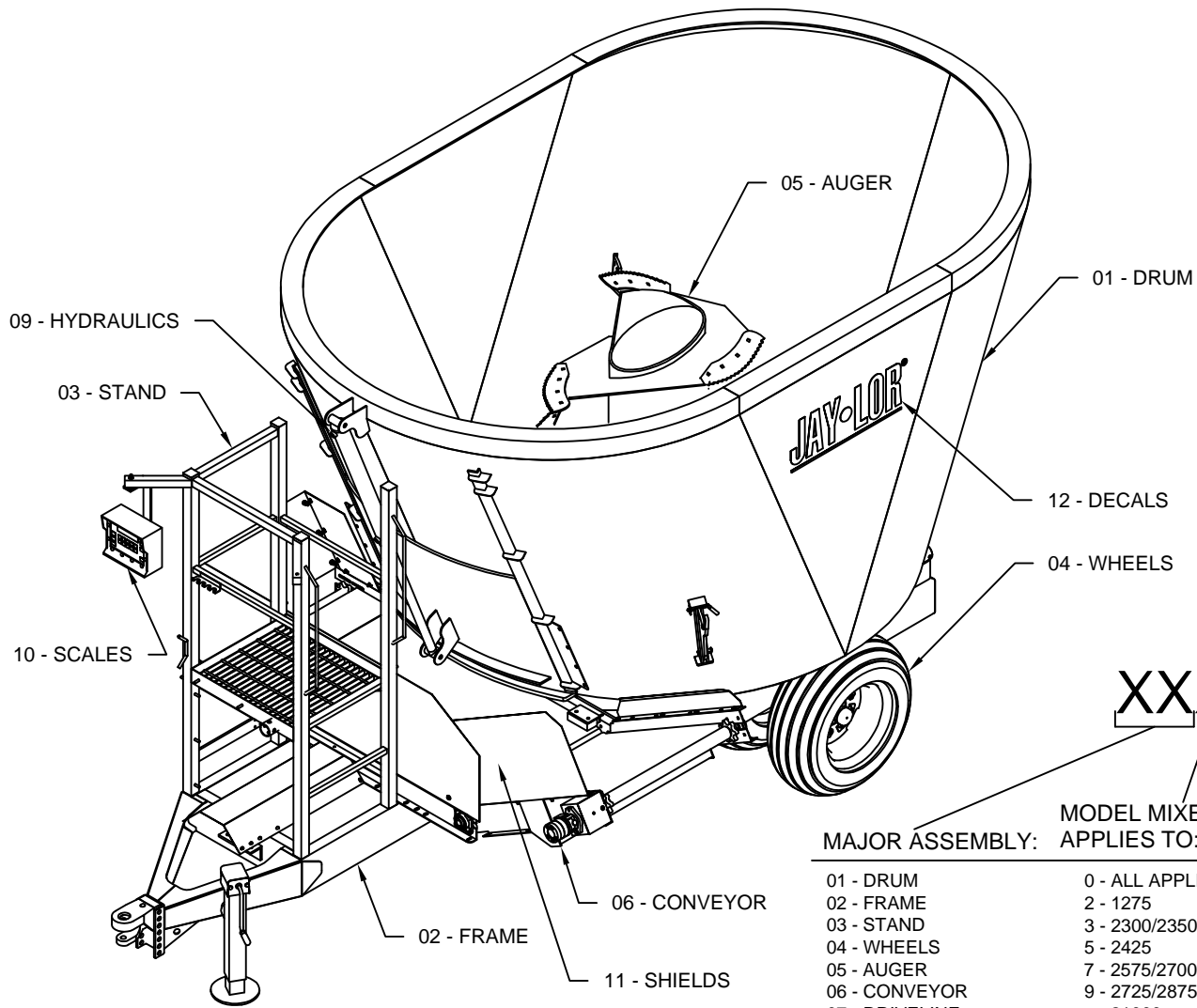

XXX - XX - XX

MAJOR ASSEMBLY:	MODEL MIXER PART APPLIES TO:	SUBASSEMBLY:	PART #:
01 - DRUM	0 - ALL APPLICABLE	00 - NO SUBASSEMBLY	00 - INCLUDES ALL PARTS
02 - FRAME	2 - 1275	XX - SUBASSEMBLY #	IN SUBASSEMBLY
03 - STAND	3 - 2300/2350		XX - PART #
04 - WHEELS	5 - 2425		
05 - AUGER	7 - 2575/2700		
06 - CONVEYOR	9 - 2725/2875		
07 - DRIVELINE	21000		
08 - LUBE SYSTEM			
09 - HYDRAULICS			
10 - SCALES			
11 - SHIELDS			
12 - DECALS			
13 - MISCELLANEOUS			
14 - BOLTS AND FASTENERS			
15 - CAPS AND SPECIAL FASTENERS			
16 - MANUALS, BULLETINS, & BROCHURES			

TITLE: PART NUMBERING SYSTEM AND CORRESPONDING LOCATION DIAGRAM FOR TYPICAL UNITS

DRAWN BY: D. RODGERS	DATE: JUN 7/00
MODEL: ALL APPLICABLE	SHEET: 1 of 1
PART/ASSEMBLY NO: 160-00-01	





TABLE OF CONTENTS

SECTION DESCRIPTION	SECTION
<i>Front Door Discharge, Center-Side Door Discharge Drum Assemblies, Restrictor Blades, etc.,</i>	01 – DRUM
<i>Frame Assembly, Hitch, Jack, etc.,</i>	02 – FRAME
<i>Stand Frame Assembly, Scale Indicator Mount, etc.,</i>	03 – STAND
<i>Tires, Rims, Tubes, Axle Spindles, Hubs, Bearings, etc.,</i>	04 – WHEELS
<i>Auger Assembly, Knives, Angling Blades, etc.,</i>	05 – AUGER
<i>Conveyor Assemblies, Apron Chain, Drive and Idler Shafts, Bearings, Chain Couplers, Hydraulic Motors, Magnet Chutes, etc.,</i>	06 – CONVEYOR
<i>Planetary Gearboxes, Transmissions, Driveshafts, P.T.O. Shafts, Bearings, etc.,</i>	07 – DRIVELINE
<i>Oil Reservoirs, Grease Lines, etc.,</i>	08 – LUBE SYSTEM
<i>Cylinders, Motors, Hose Kits, Valves, Fittings, etc.,</i>	09 – HYDRAULICS
<i>Scale Indicators, Weighbars, Power Cords, etc.,</i>	10 – SCALES
<i>Conveyor Shield Assemblies, Driveline Shielding, Special Guards, etc.,</i>	11 – SHIELDS
<i>O.E.M. Decals, Safety Decals, etc.,</i>	12 – DECALS
<i>Parts Order Forms, Warranty Request Forms, etc.,</i>	SERVICE DEPARTMENT DOCUMENTS/FORMS

JAY•LOR[®]

Cutter • Mixer • Feeder

01 - DRUM

"Putting the 'Total' into TMR"

JAY-LOR[®] Fabricating Inc.
RR # 2 Orton, Ontario, Canada, L0N 1N0 Tel: (519) 787-9353 Fax: (519) 787-7053

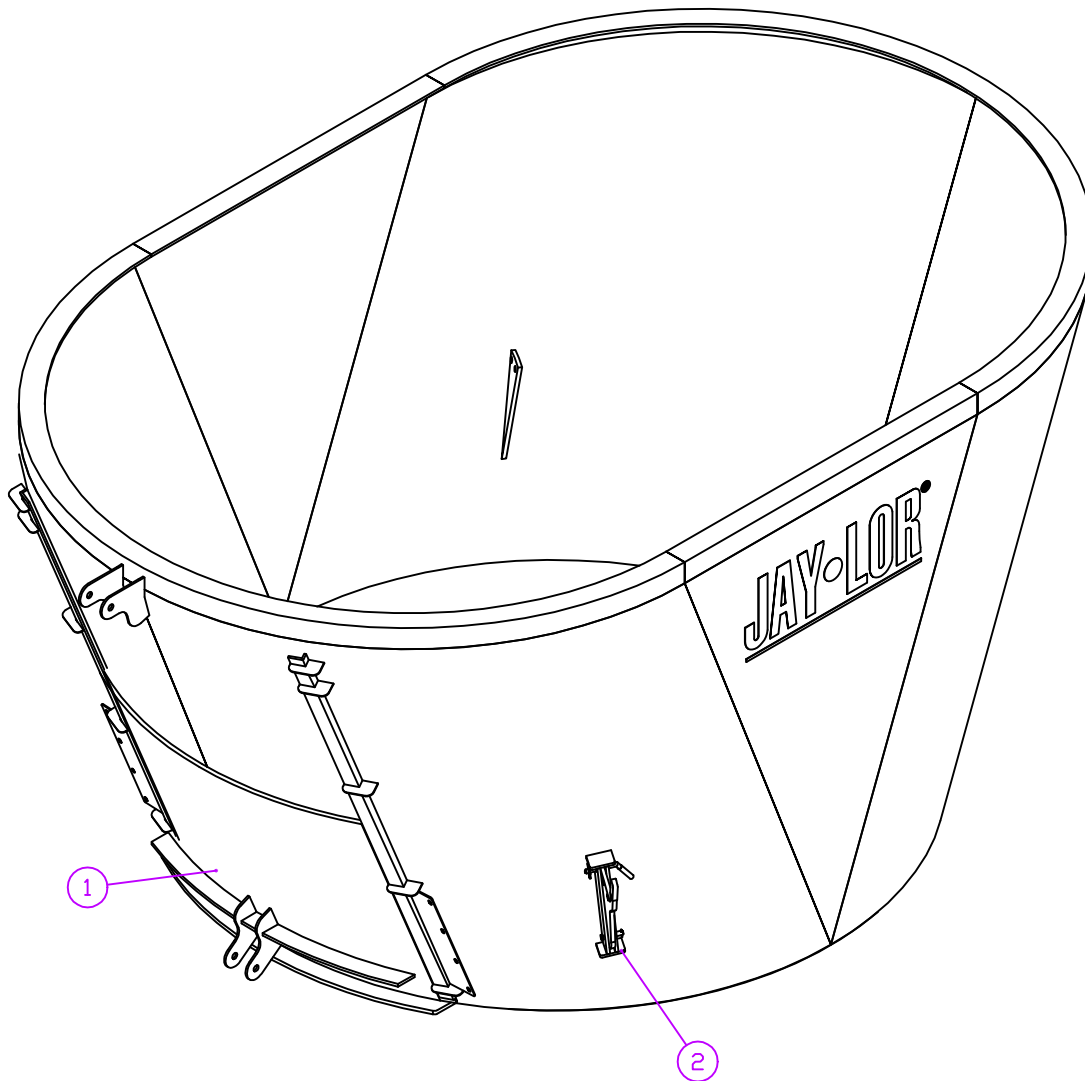

* - SPECIAL USE ONLY

3	DRUM LINER (NOT SHOWN)*	1	VARIES
2	RESTRICTOR BLADE ASSEMBLY	2	013-11-01
1	FRONT DOOR ASSEMBLY	1	013-10-01
NO.	PART DESC.	QTY	PART NO.

PARTS LIST

DRAWN BY: D. RODGERS		DATE: JUL 31/00	
MODEL: 2350		SHEET: 1 of 1	
PART/ASSEMBLY NO:		013-06-01	

JAY-LOR
Fabricating Inc

TITLE: MODEL 2350 FRONT DISCHARGE DRUM ASSEMBLY COMPONENTS

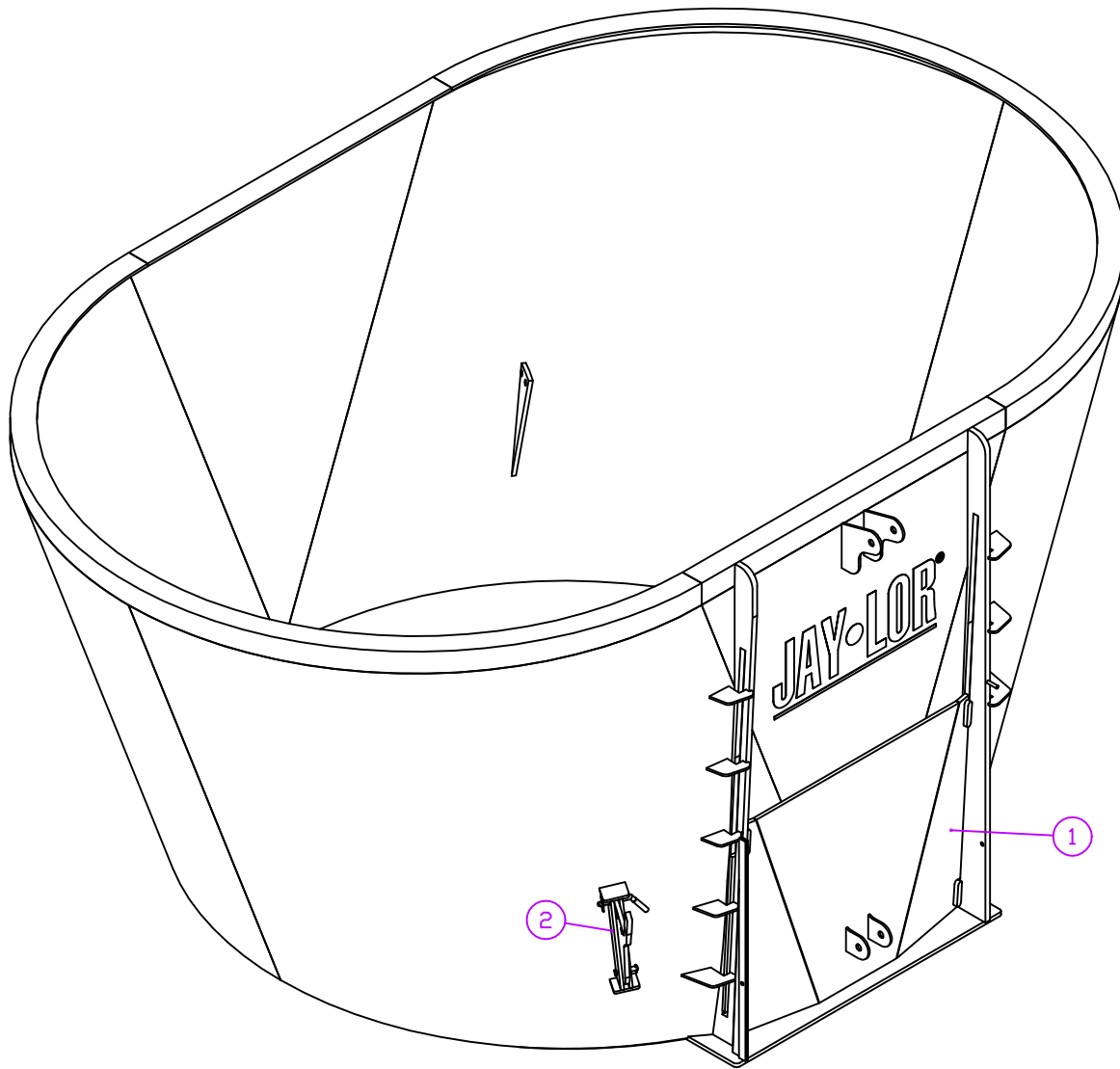

* - SPECIAL USE ONLY

3	DRUM LINER (NOT SHOWN)*	1	VARIES*
2	RESTRICTOR BLADE ASSEMBLY	2	013-11-01
1	CENTER-SIDE DOOR ASSEMBLY	1	013-10-02
NO.	PART DESC.	QTY	PART NO.

PARTS LIST

DRAWN BY: D. RODGERS		DATE: JUL 31/00	
MODEL: 2350		SHEET: 1 of 1	
PART/ASSEMBLY NO:		013-06-02	



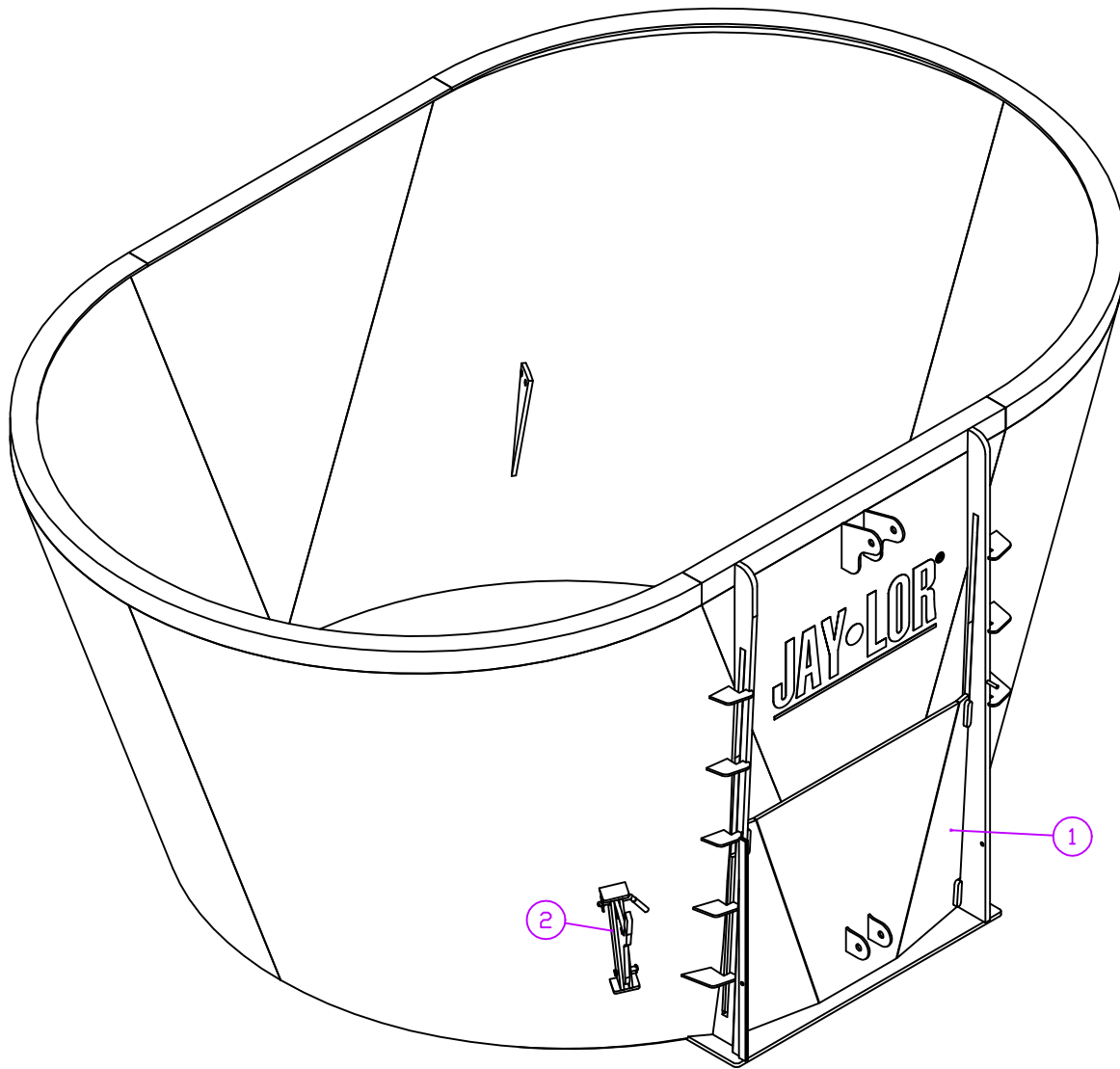

* - SPECIAL USE ONLY

3	DRUM LINER (NOT SHOWN)*	1	VARIES*
2	RESTRICTOR BLADE ASSEMBLY	2	013-11-01
1	CENTER-SIDE DOOR ASSEMBLY	1	013-10-02
NO.	PART DESC.	QTY	PART NO.

PARTS LIST

DRAWN BY: D. RODGERS		DATE: JUL 31/00	
MODEL: 2350		SHEET: 1 of 1	
PART/ASSEMBLY NO:		013-06-02	



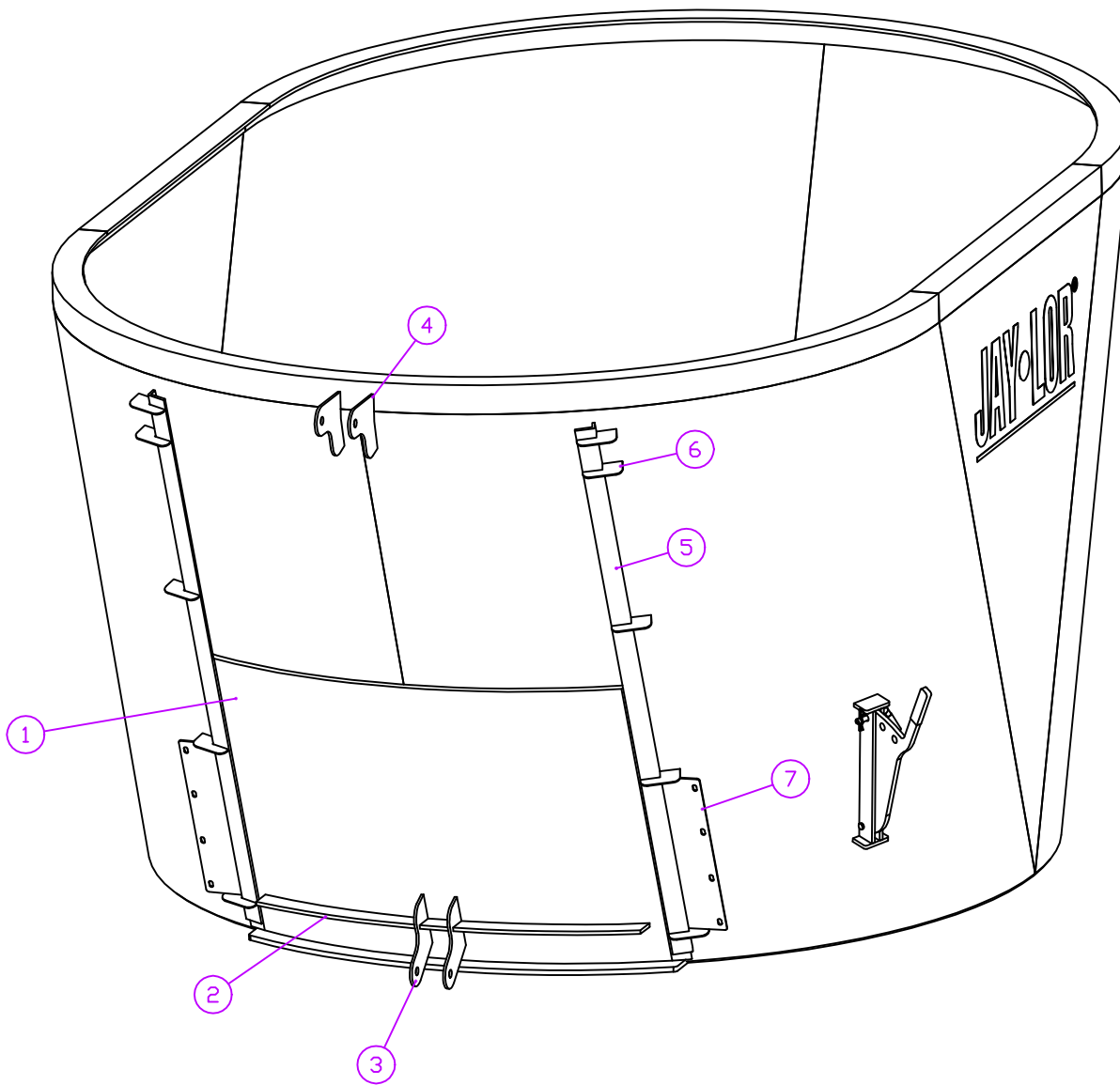

7	CONVEYOR SHIELD MOUNT	2	010-00-16
6	DOOR RAIL SUPPORT CLIPS	10	010-00-62
5	FRONT DOOR RAILS (ONE-PIECE)	2	010-07-02
4	TOP CYLINDER BRACKET	2	010-00-22
3	LOWER CYLINDER BRACKET	2	010-00-23
2	ROLLED FLATBAR REINFORCEMENT	1	010-00-06
1	FRONT DOOR (ONE-PIECE)	1	013-00-04
NO.	PART DESC.	QTY	PART NO.

PARTS LIST

DRAWN BY:	D. RODGERS	DATE:	JUL 31/00
MODEL:	2350	SHEET:	1 of 1
PART/ASSEMBLY NO.:	013-10-01		

JAY•LOR
Fabricating Inc

TITLE: MODEL 2350 FRONT DISCHARGE DOOR ASSEMBLY

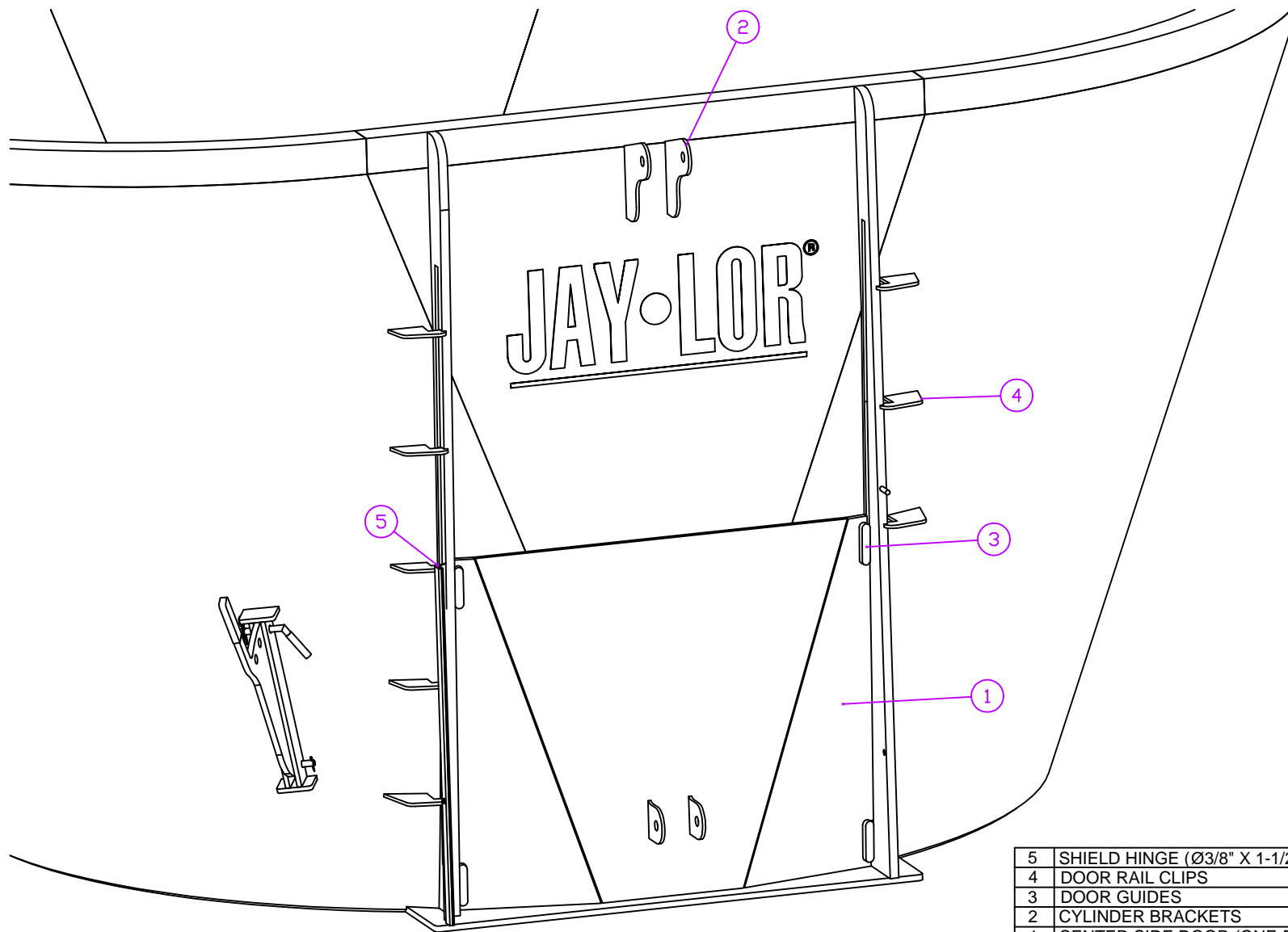

5	SHIELD HINGE (Ø3/8" X 1-1/2" BOLT)	2	140-00-17
4	DOOR RAIL CLIPS	8	010-00-82
3	DOOR GUIDES	4	010-00-83
2	CYLINDER BRACKETS	4	010-00-23
1	CENTER SIDE DOOR (ONE-PIECE)	1	010-00-84
NO.	PART DESC.	QTY	PART NO.

PARTS LIST

DRAWN BY: D. RODGERS	DATE: JUL 31/00
MODEL: 2350	SHEET 1 of 1
PART/ASSEMBLY NO: 013-10-02	

JAY-LOR
Fabricating Inc

TITLE: MODEL 2350 CENTER-SIDE DISCHARGE DOOR ASSEMBLY

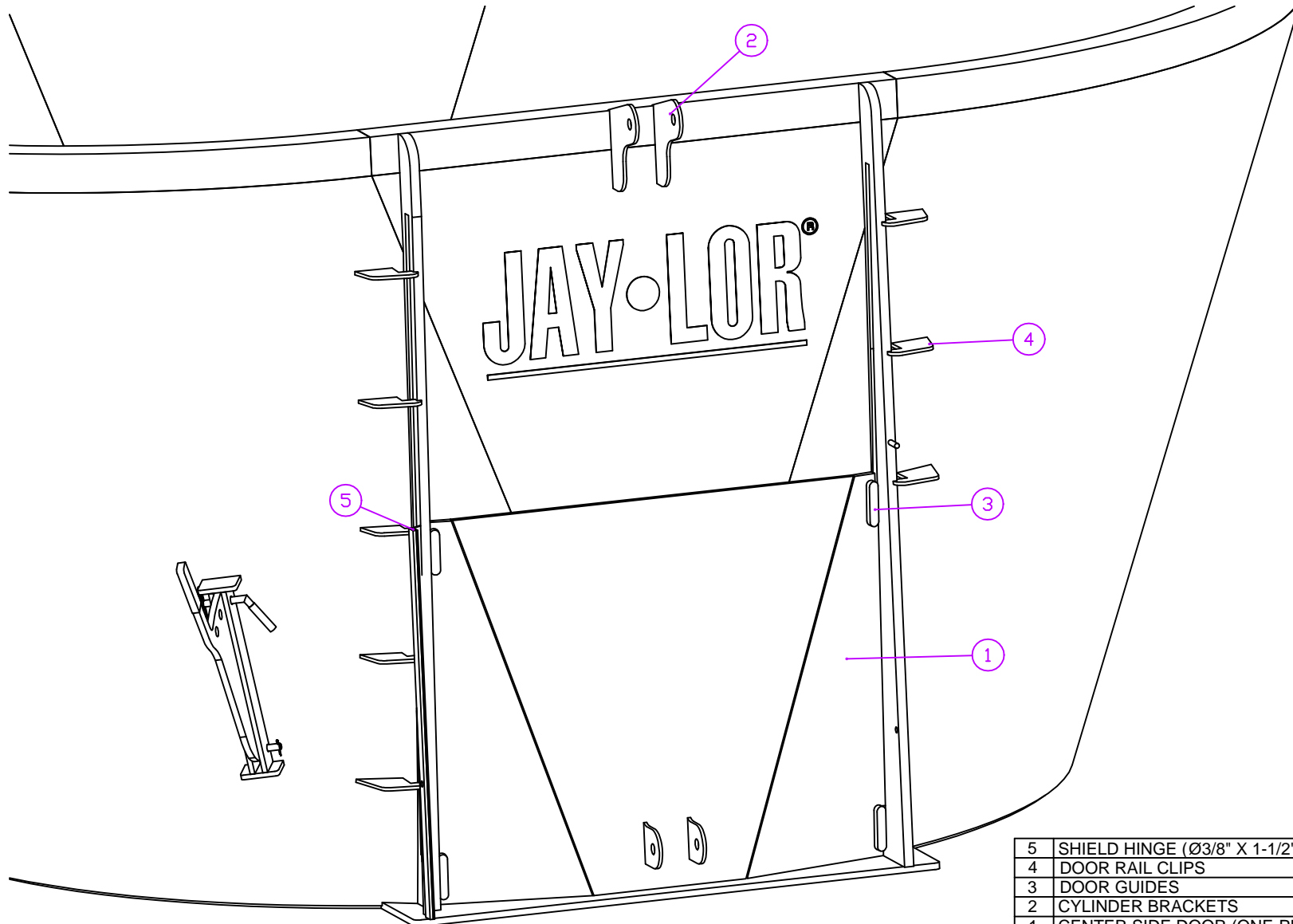

5	SHIELD HINGE (Ø3/8" X 1-1/2" BOLT)	2	140-00-17
4	DOOR RAIL CLIPS	8	010-00-82
3	DOOR GUIDES	4	010-00-83
2	CYLINDER BRACKETS	4	010-00-23
1	CENTER SIDE DOOR (ONE-PIECE)	1	010-00-84
NO.	PART DESC.	QTY	PART NO.

PARTS LIST

DRAWN BY: D. RODGERS	DATE: JUL 31/00
MODEL: 2300	SHEET: 1 of 1
PART/ASSEMBLY NO: 013-10-03	



TITLE: MODEL 2300 CENTER-SIDE DISCHARGE DOOR ASSEMBLY

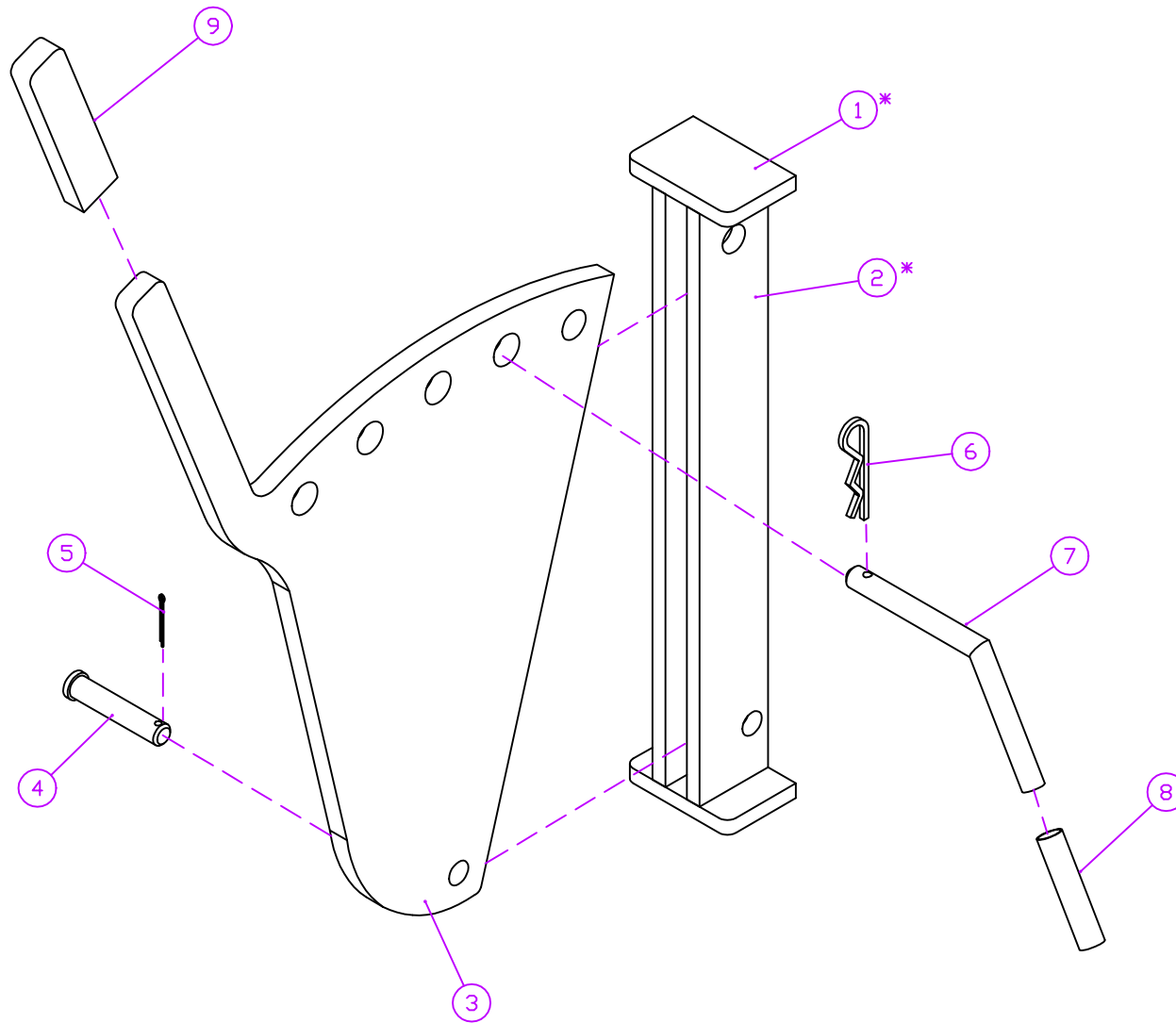

* - NOT INCLUDED W/ ASSEMBLY

9	RESTRICTOR BLADE GRIP	1	150-00-03
8	ADJUSTMENT PIN CAP	1	150-00-02
7	ADJUSTMENT PIN	1	010-01-08
6	HAIRPIN	1	010-01-07
5	COTTER PIN	1	010-01-06
4	BOTTOM PIVOT PIN	1	010-01-04
3	RESTRICTOR BLADE	1	010-01-02
2	SIDE BRACKETS*	2	010-02-02
1	END PLATES*	2	010-02-01
NO.	PART DESC.	QTY	PART NO.

PARTS LIST

DRAWN BY:	D. RODGERS	DATE:	JUL 31/00
MODEL:	2300/2350	SHEET:	1 of 1
PART/ASSEMBLY NO.:	013-11-01		

JAY•LOR
Fabricating Inc

TITLE: STANDARD RESTRICTOR BLADE ASSEMBLY

JAY•LOR[®]

Cutter • Mixer • Feeder

02 - FRAME

"Putting the 'Total' into TMR"

JAY-LOR[®] Fabricating Inc.
RR # 2 Orton, Ontario, Canada, L0N 1N0 Tel: (519) 787-9353 Fax: (519) 787-7053

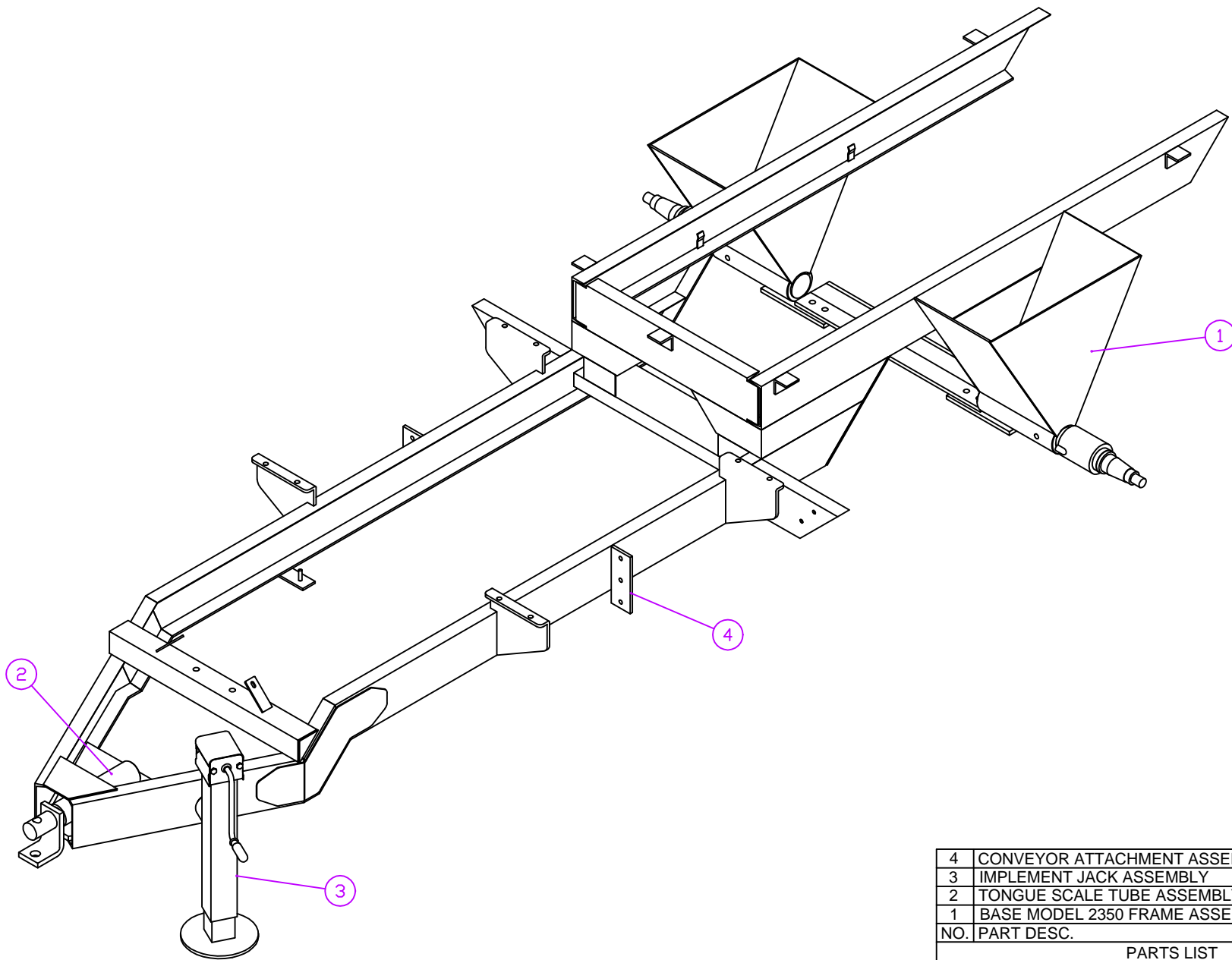

4	CONVEYOR ATTACHMENT ASSEMBLY	1	023-08-01
3	IMPLEMENT JACK ASSEMBLY	1	020-02-01
2	TONGUE SCALE TUBE ASSEMBLY	1	023-14-01
1	BASE MODEL 2350 FRAME ASSEMBLY	1	023-06-01
NO.	PART DESC.	QTY	PART NO.

PARTS LIST

DRAWN BY: D. RODGERS		DATE: AUG 1/00	
MODEL: 2350		SHEET: 1 of 1	
PART/ASSEMBLY NO: 023-05-01			
TITLE: MODEL 2350 COMPLETE FRAME ASSEMBLY (FRONT DISCHARGE)			

TITLE: MODEL 2350 COMPLETE FRAME ASSEMBLY (FRONT DISCHARGE)

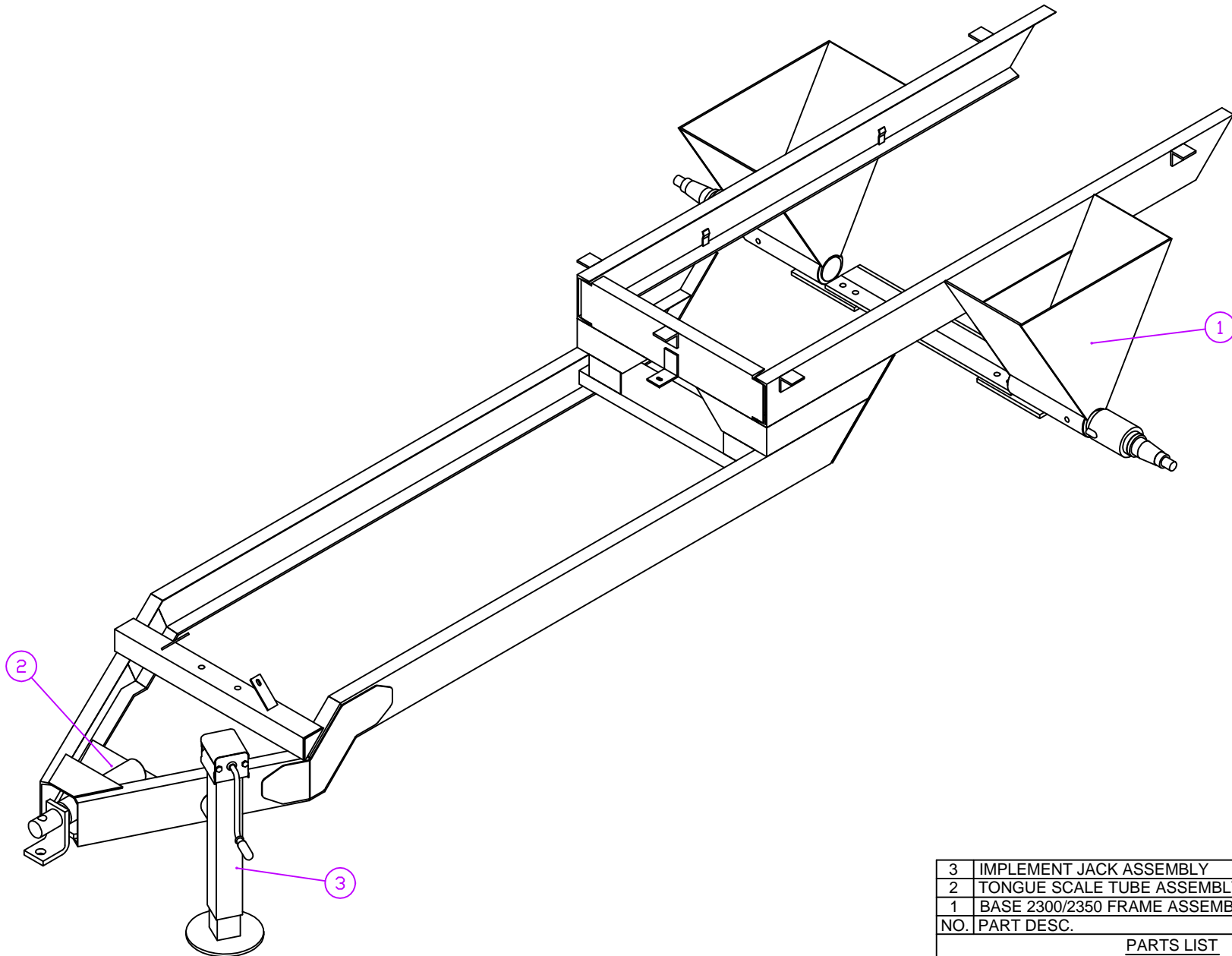

3	IMPLEMENT JACK ASSEMBLY	1	020-02-01
2	TONGUE SCALE TUBE ASSEMBLY	1	023-14-01
1	BASE 2300/2350 FRAME ASSEMBLY	1	023-06-02
NO.	PART DESC.	QTY	PART NO.

PARTS LIST

DRAWN BY: D. RODGERS		DATE: AUG 1/00	
MODEL: 2300/2350		SHEET: 1 of 1	
PART/ASSEMBLY NO:		023-05-02	



TITLE: MODEL 2300/2350 COMPLETE FRAME ASSEMBLY (CENTER-SIDE DISCHARGE)

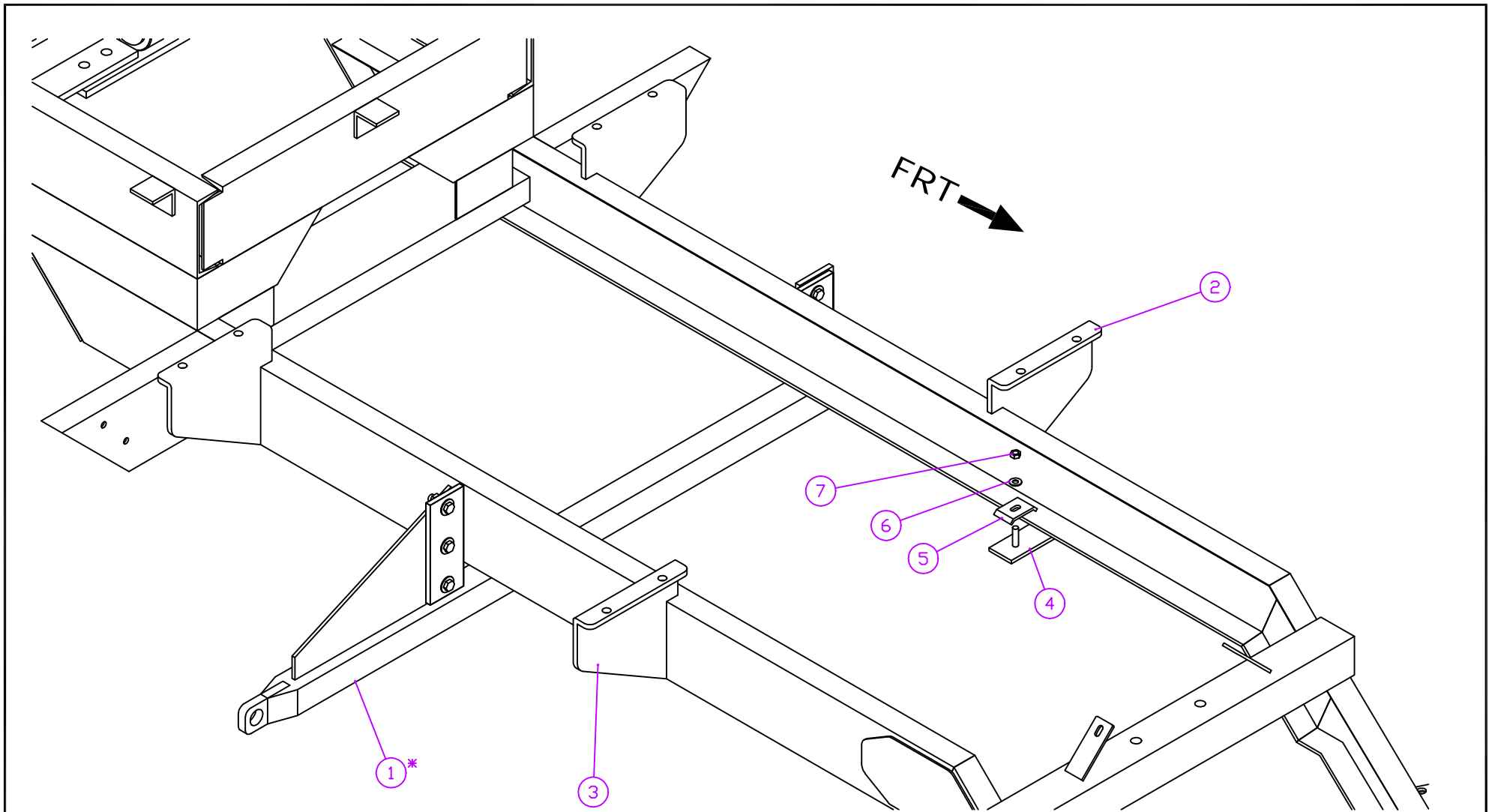

7	Ø3/8" FLAT WASHER	1	140-00-66
6	Ø3/8" NUT	1	140-00-85
5	HYDRAULIC HOSE CLIP	1	020-00-09
4	HYDRAULIC HOSE MOUNT	2	020-00-13
3	CONVEYOR MOUNT (PIECE 'B')	2	023-00-36
2	CONVEYOR MOUNT (PIECE 'A')	2	023-00-35
1	UNDERCARRIAGE BAR ASSEMBLY	1	020-03-01
NO.	PART DESC.	QTY	PART NO.

* - DELETE ASSEMBLY #020-03-01 IF DUAL DIRECTION DISCHARGE CONVEYOR OPTION SPECIFIED.

PARTS LIST

DRAWN BY: D. RODGERS	DATE: AUG 1/00
MODEL: 2350	SHEET: 1 of 1
PART/ASSEMBLY NO: 023-08-01	

JAY•LOR
Fabricating Inc

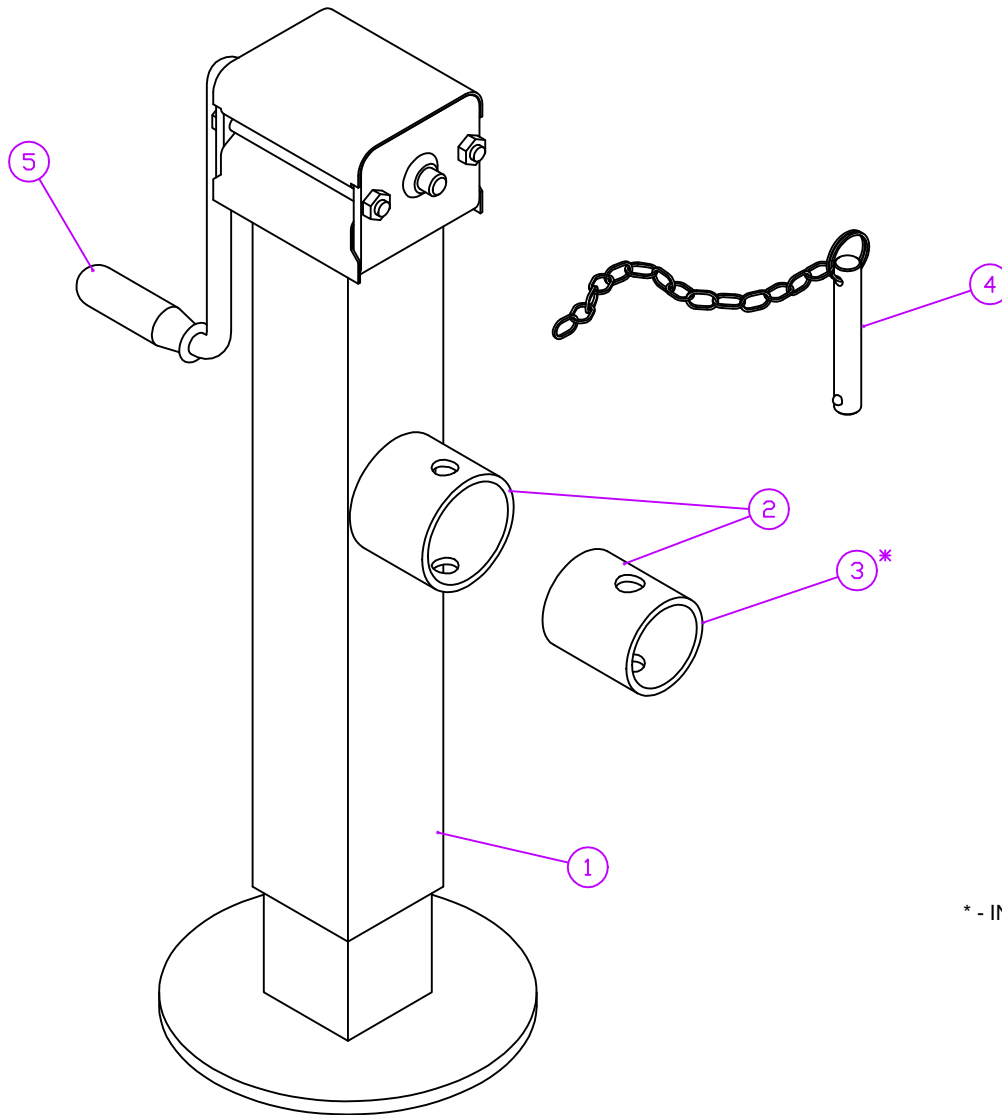

* - INNER SLEEVE W/ PART NUMBER 030-00-19 SAME AS 020-02-04

NO.	PART DESC.	QTY	PART NO.
5	IMPLEMENT JACK HANDLE ASSEMBLY	1	020-02-06
4	PIN AND CHAIN KIT	1	020-02-05
3	(1) INNER SLEEVE*	1	020-02-04
2	(2) INNER & (1) OUTER SLEEVE KIT	1	020-02-03
1	IMPLEMENT JACK W/ HANDLE	1	020-02-02
NO.	PART DESC.	QTY	PART NO.

PARTS LIST

DRAWN BY: D. RODGERS		DATE: MAY 5/00	
MODEL: ALL APPLICABLE		SHEET: 1 of 1	
PART/ASSEMBLY NO: 020-02-01			



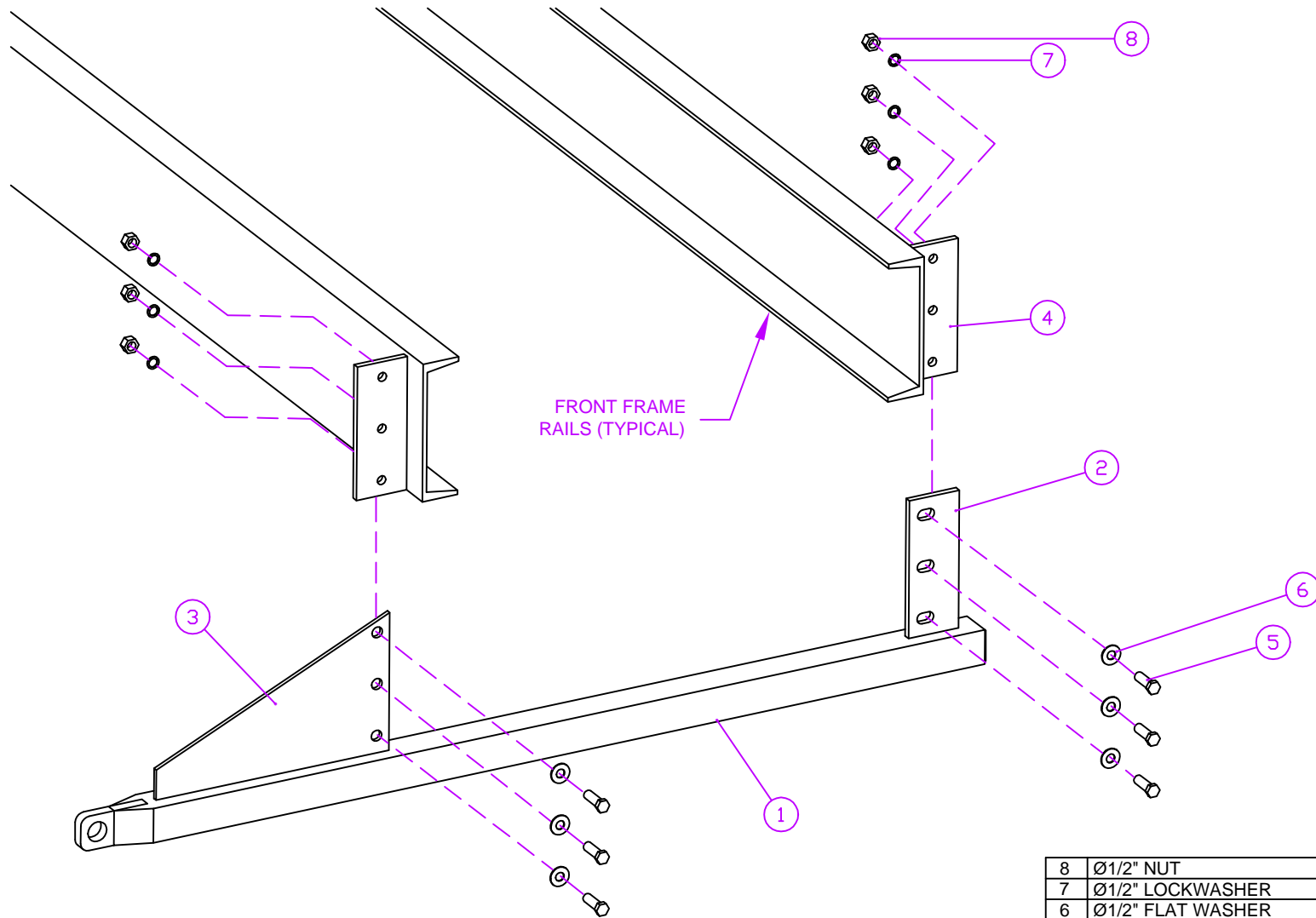

NOTE:

- 2 UNDERCARRIAGE BAR ASSEMBLIES REQUIRED FOR DUAL CYLINDER LIFT KIT.
- DUAL CYLINDER LIFT KIT USED ON MODELS EQUIPPED W/ WING EXTENSION CONVEYORS OVER 41" OVERALL LENGTH.

8	Ø1/2" NUT	6	140-00-76
7	Ø1/2" LOCKWASHER	6	140-00-72
6	Ø1/2" FLAT WASHER	6	140-00-67
5	Ø1/2" X 1-1/2" BOLT	6	140-00-24
4	UNDERCARRIAGE BAR MOUNT	2	020-00-04
3	TRIANGULAR SUPPORT PLATE	1	020-00-06
2	SUPPORT PLATE	1	020-00-05
1	WING LIFT SUPPORT TUBE	1	020-00-03
NO.	PART DESC.	QTY	PART NO.

PARTS LIST

DRAWN BY: D. RODGERS	DATE: MAY 8/00
MODEL: ALL APPLICABLE	SHEET: 1 of 1
PART/ASSEMBLY NO: 020-03-01	

JAY•LOR
Fabricating Inc

JAY•LOR[®]

Cutter • Mixer • Feeder

03 - STAND

"Putting the 'Total' into TMR"

JAY-LOR[®] Fabricating Inc.
RR # 2 Orton, Ontario, Canada, L0N 1N0 Tel: (519) 787-9353 Fax: (519) 787-7053

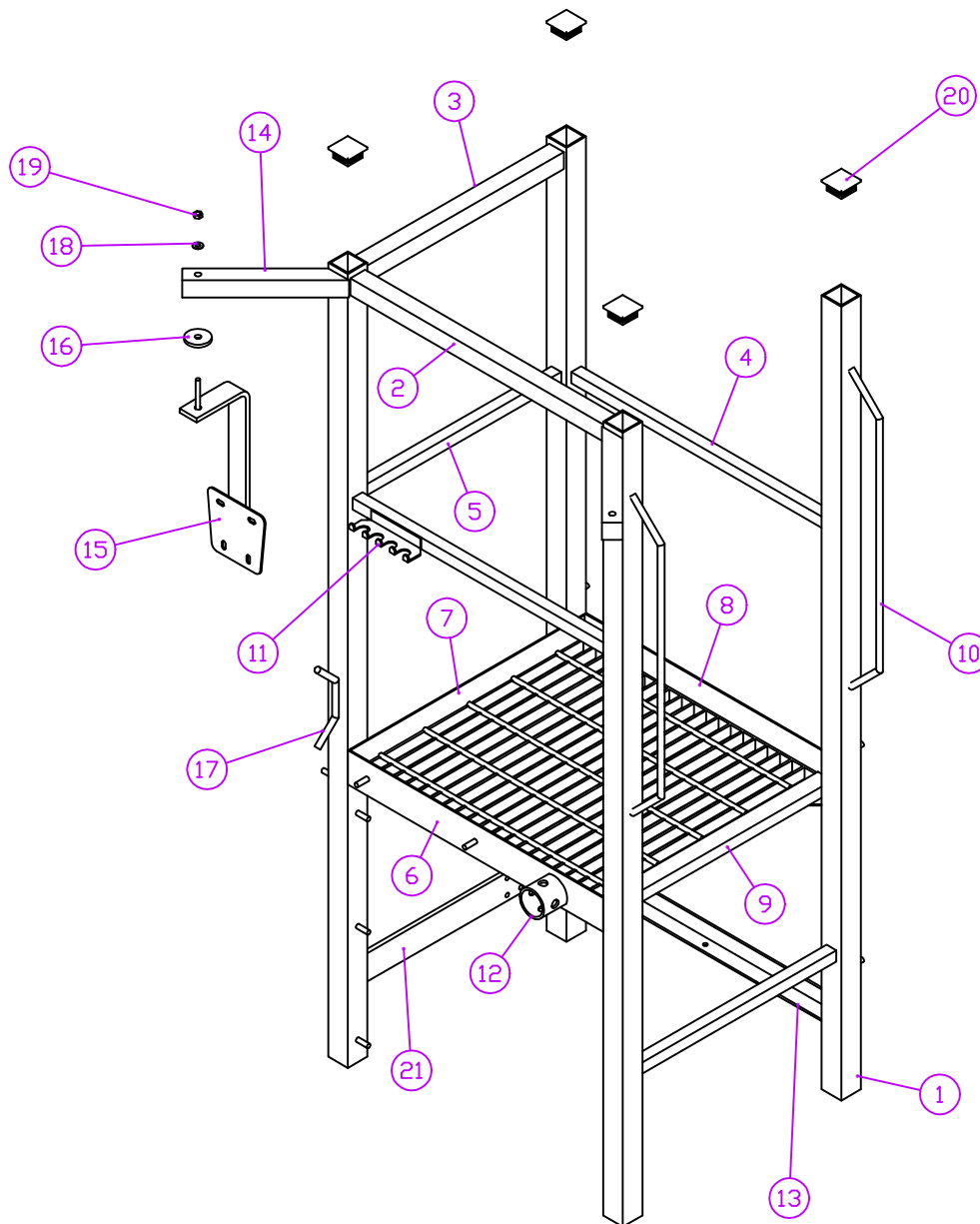

21	RESERVOIR MOUNT	1	030-00-30
20	PLASTIC END CAPS	4	150-00-04
19	Ø1/2" LOCKNUT	1	140-00-89
18	Ø1/2" FLAT WASHER	1	140-00-67
17	WIRE/ROPE TIE	1	030-00-34
16	URETHANE WASHER	1	030-00-25
15	SCALE INDICATOR MOUNT BRACKET	1	030-00-24
14	SCALE INDICATOR MOUNTING TUBE	2	030-00-23
13	DRIVESHAFT SHIELD MOUNT ANGLE	1	030-00-20
12	IMPLEMENT JACK INNER SLEEVE	1	030-00-19
11	HOSE HOLDER (4-SLOT)	1	030-00-14
10	STAND LADDER HANDLES	2	030-00-12
9	PLATFORM GRATING - GALVANIZED	1	030-00-11
8	PLATFORM SUPPORT ANGLE - REAR	1	030-00-10
7	PLATFORM SUPPORT ANGLE - SIDE	1	030-00-09
6	PLATFORM SUPPORT ANGLE - FRONT	1	030-00-08
5	SIDE STAND TUBES	2	030-00-07
4	FRONT AND REAR STAND TUBES	2	030-00-06
3	TOP SIDE STAND TUBE	1	030-00-05
2	TOP FRONT STAND TUBE	1	030-00-04
1	STAND LEGS	4	030-00-01
NO.	PART DESC.	QTY	PART NO.

PARTS LIST

DRAWN BY: D. RODGERS	DATE: JUL 27/00
MODEL: 2300/2350	SHEET: 1 of 1
PART/ASSEMBLY NO: 033-05-01	

JAY-LOR
Fabricating Inc

TITLE: BASE STAND FRAME ASSEMBLY FOR MODELS 2300/2350

JAY•LOR[®]

Cutter • Mixer • Feeder

04 - WHEELS

"Putting the 'Total' into TMR"

JAY-LOR[®] Fabricating Inc.
RR # 2 Orton, Ontario, Canada, L0N 1N0 Tel: (519) 787-9353 Fax: (519) 787-7053

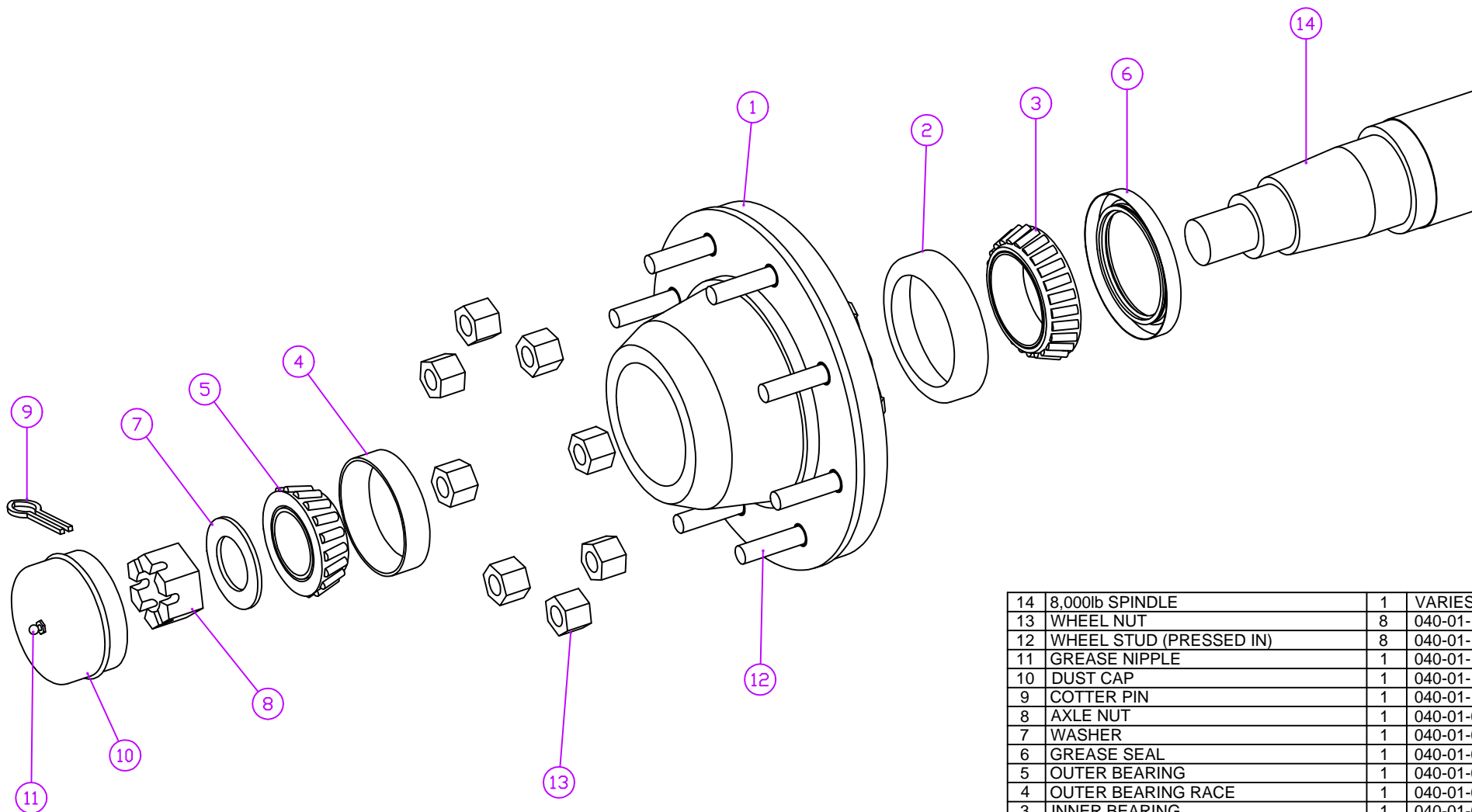

14	8,000lb SPINDLE	1	VARIABLES
13	WHEEL NUT	8	040-01-14
12	WHEEL STUD (PRESSED IN)	8	040-01-13
11	GREASE NIPPLE	1	040-01-12
10	DUST CAP	1	040-01-11
9	COTTER PIN	1	040-01-10
8	AXLE NUT	1	040-01-09
7	WASHER	1	040-01-08
6	GREASE SEAL	1	040-01-06
5	OUTER BEARING	1	040-01-05
4	OUTER BEARING RACE	1	040-01-04
3	INNER BEARING	1	040-01-03
2	INNER BEARING RACE	1	040-01-02
1	8,000lb 8BH CASTING	1	040-01-01
NO.	PART DESC.	QTY	PART NO.

PARTS LIST

DRAWN BY:		DATE:	
D. RODGERS		MAY 4/00	
MODEL:		SHEET:	
ALL APPLICABLE		1 of 4	
PART/ASSEMBLY NO:		040-01-00	

JAY•LOR
Fabricating Inc

TITLE: 8,000lb, 8 BOLT HUB COMPLETE ASSEMBLY AND COMPONENTS (W/O SPINDLE)

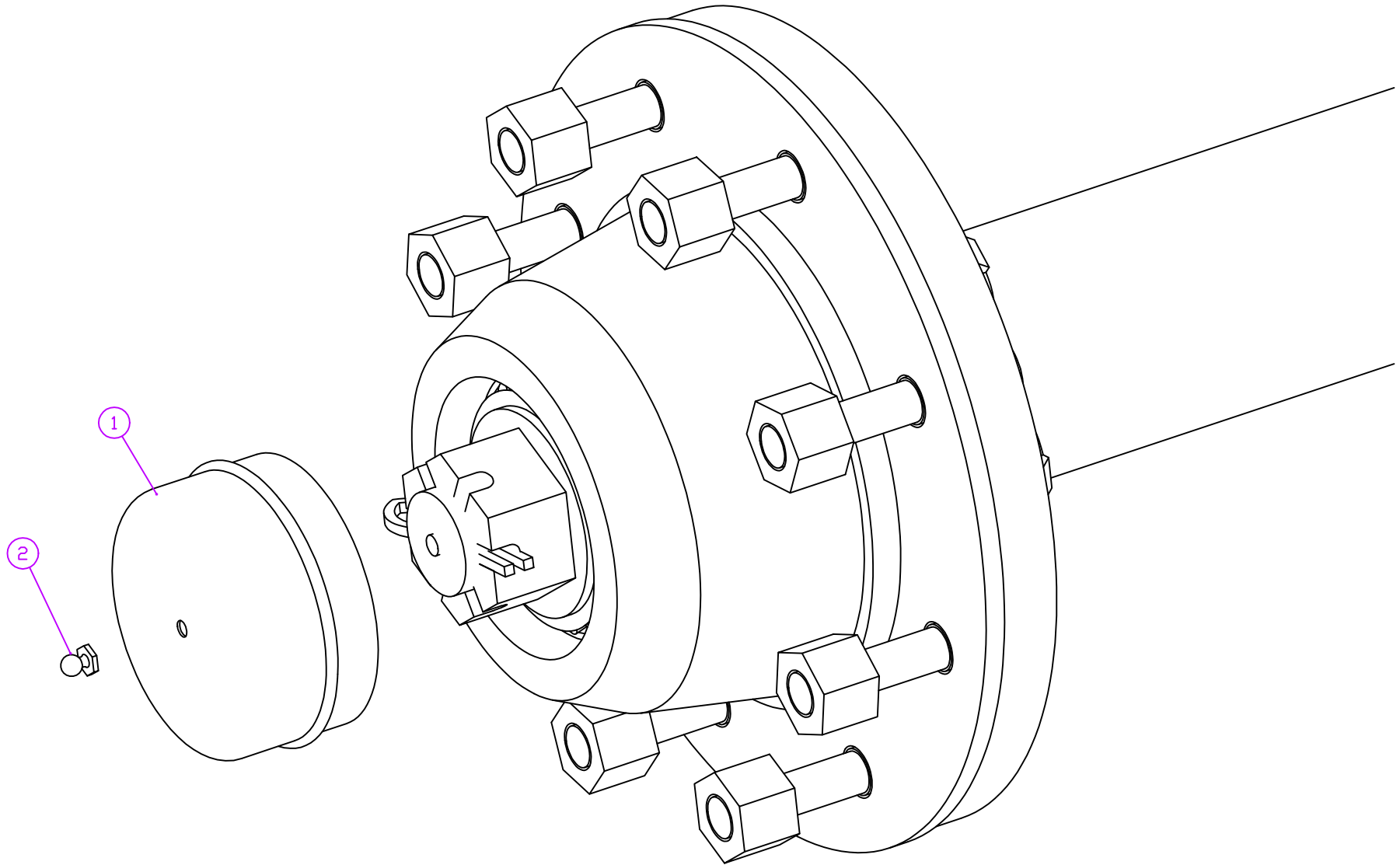

2	GREASE NIPPLE	1	040-01-12
1	DUST CAP	1	040-01-11
NO.	PART DESC.	QTY	PART NO.

PARTS LIST

DRAWN BY: D. RODGERS	DATE: MAY 4/00
MODEL: ALL APPLICABLE	SHEET: 2 of 4
PART/ASSEMBLY NO: 040-01-50	



TITLE: 8,000lb, 8 BOLT HUB - DUST CAP ASSEMBLY

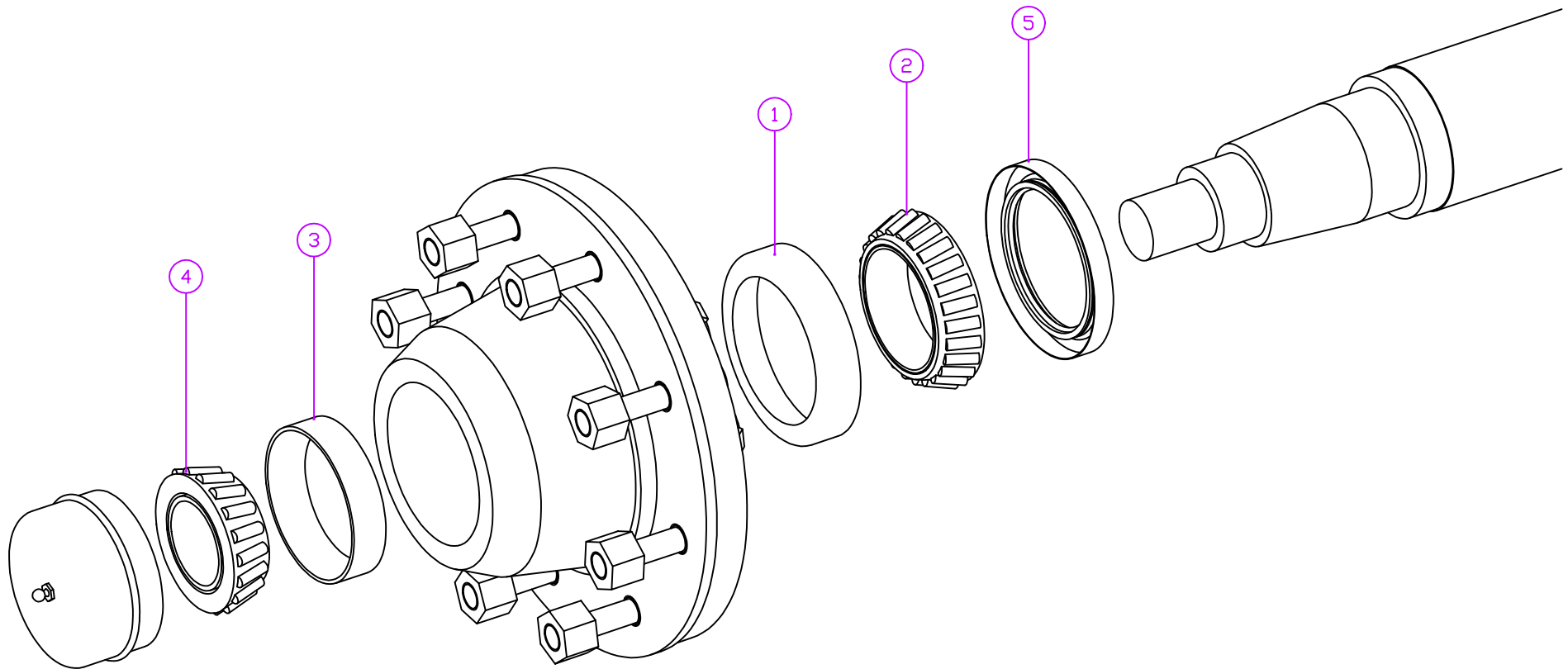

5	GREASE SEAL	1	040-01-06
4	OUTER BEARING	1	040-01-05
3	OUTER BEARING RACE	1	040-01-04
2	INNER BEARING	1	040-01-03
1	INNER BEARING RACE	1	040-01-02
NO.	PART DESC.	QTY	PART NO.

PARTS LIST

DRAWN BY: D. RODGERS		DATE: MAY 4/00	
MODEL: ALL APPLICABLE		SHEET: 3 of 4	
PART/ASSEMBLY NO:		040-01-51	

JAY•LOR
Fabricating Inc

TITLE: 8,000lb, 8 BOLT HUB - BEARING AND SEAL KIT

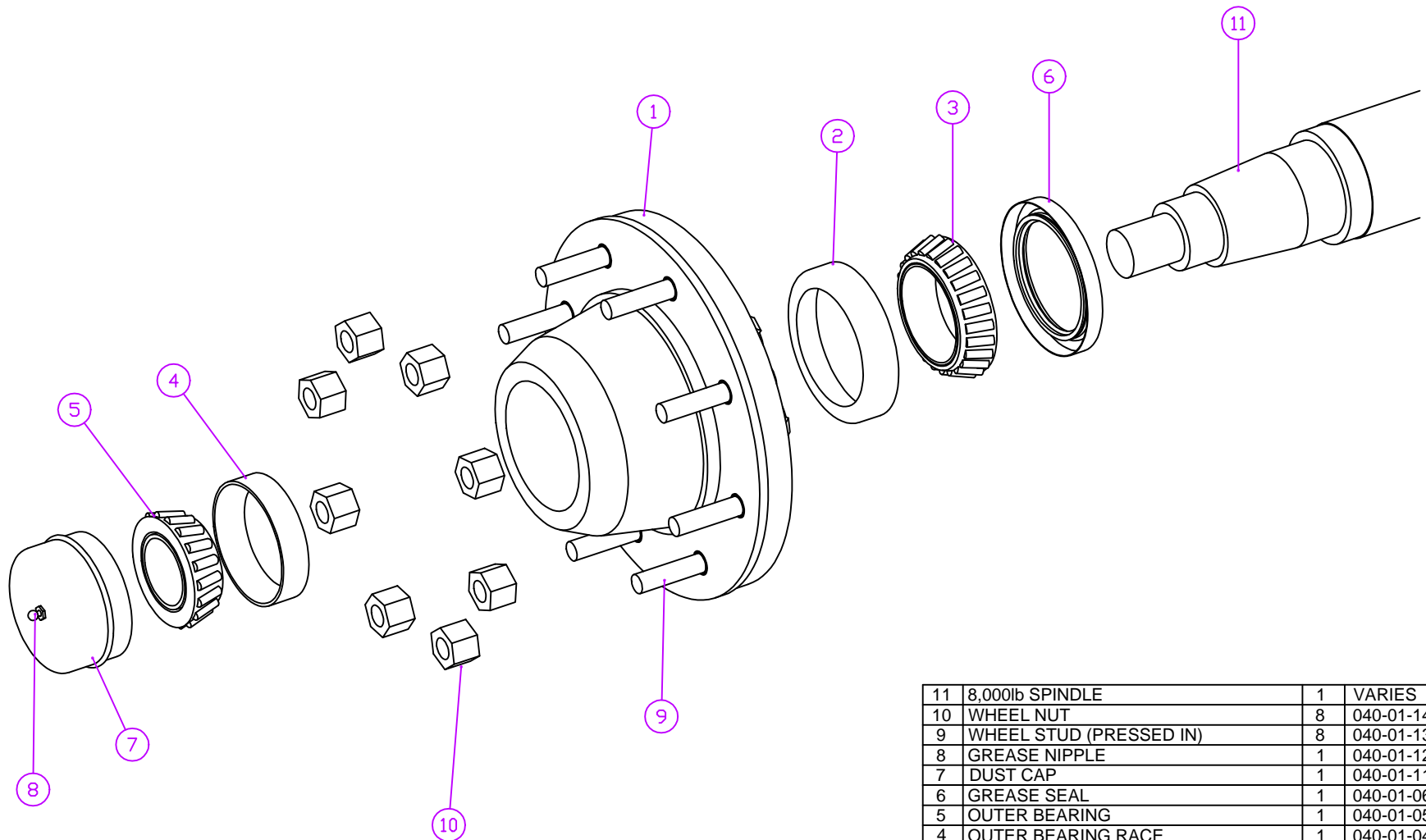

11	8,000lb SPINDLE	1	VARIABLES
10	WHEEL NUT	8	040-01-14
9	WHEEL STUD (PRESSED IN)	8	040-01-13
8	GREASE NIPPLE	1	040-01-12
7	DUST CAP	1	040-01-11
6	GREASE SEAL	1	040-01-06
5	OUTER BEARING	1	040-01-05
4	OUTER BEARING RACE	1	040-01-04
3	INNER BEARING	1	040-01-03
2	INNER BEARING RACE	1	040-01-02
1	8,000lb 8BH CASTING	1	040-01-01
NO.	PART DESC.	QTY	PART NO.

PARTS LIST

DRAWN BY:		DATE:	
D. RODGERS		MAY 4/00	
MODEL:		SHEET:	
ALL APPLICABLE		4 of 4	
PART/ASSEMBLY NO.:		040-01-52	

JAY-LOR
Fabricating Inc

TITLE: 8,000lb, 8 BOLT HUB - ALL ASSEMBLY COMPONENTS EXCEPT AXLE NUT, WASHER, & COTTER PIN

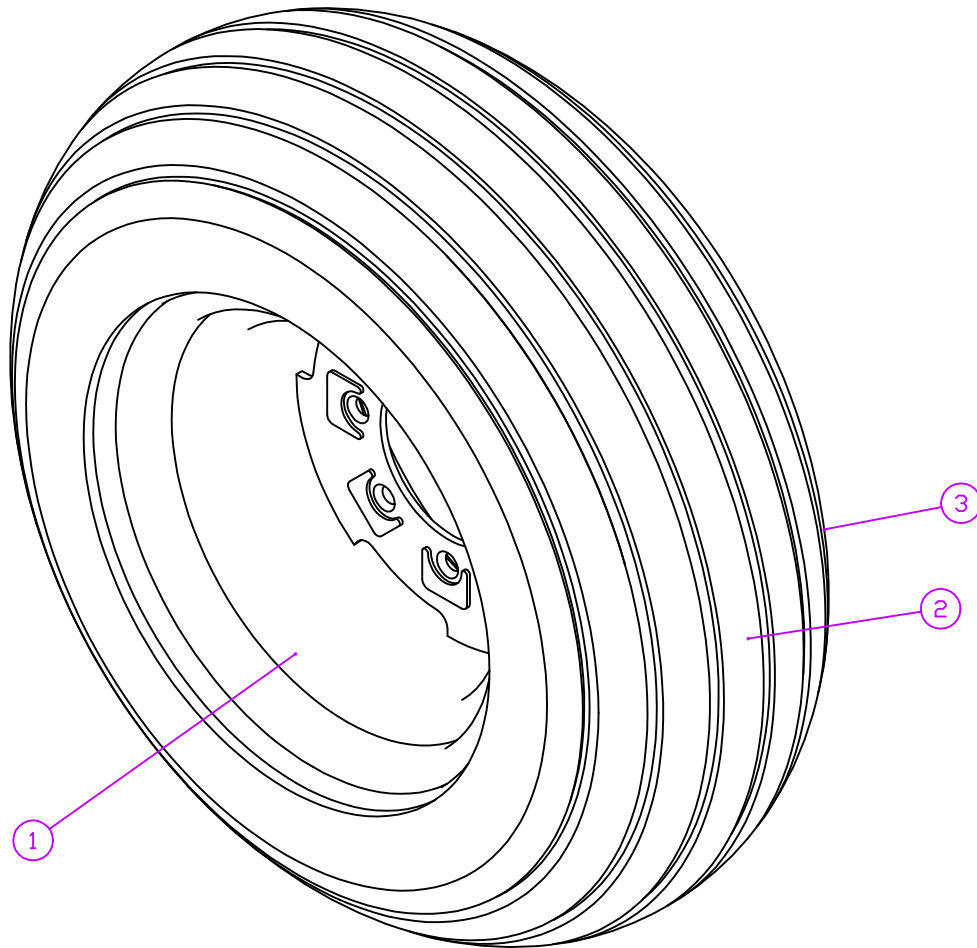

3	FIRESTONE TIRE - 12.5X16, 12 PLY	1	040-07-04
2	TUBE - 12.5X16	1	040-07-03
1	RIM - 16X10, 8 BOLT, 6,000lb	1	040-07-02
NO.	PART DESC.	QTY	PART NO.

PARTS LIST

DRAWN BY: D. RODGERS		DATE: MAY 4/00	
MODEL: ALL APPLICABLE		SHEET: 1 of 1	
PART/ASSEMBLY NO:		040-07-01	



TITLE: WHEEL ASSEMBLY - 12.5X16, 12 PLY FIRESTONE TIRE W/ TUBE ON 16X10, 8 BOLT, 6,000lb RIM

JAY•LOR[®]

Cutter • Mixer • Feeder

05 - AUGER

"Putting the 'Total' into TMR"

JAY-LOR[®] Fabricating Inc.
RR # 2 Orton, Ontario, Canada, L0N 1N0 Tel: (519) 787-9353 Fax: (519) 787-7053

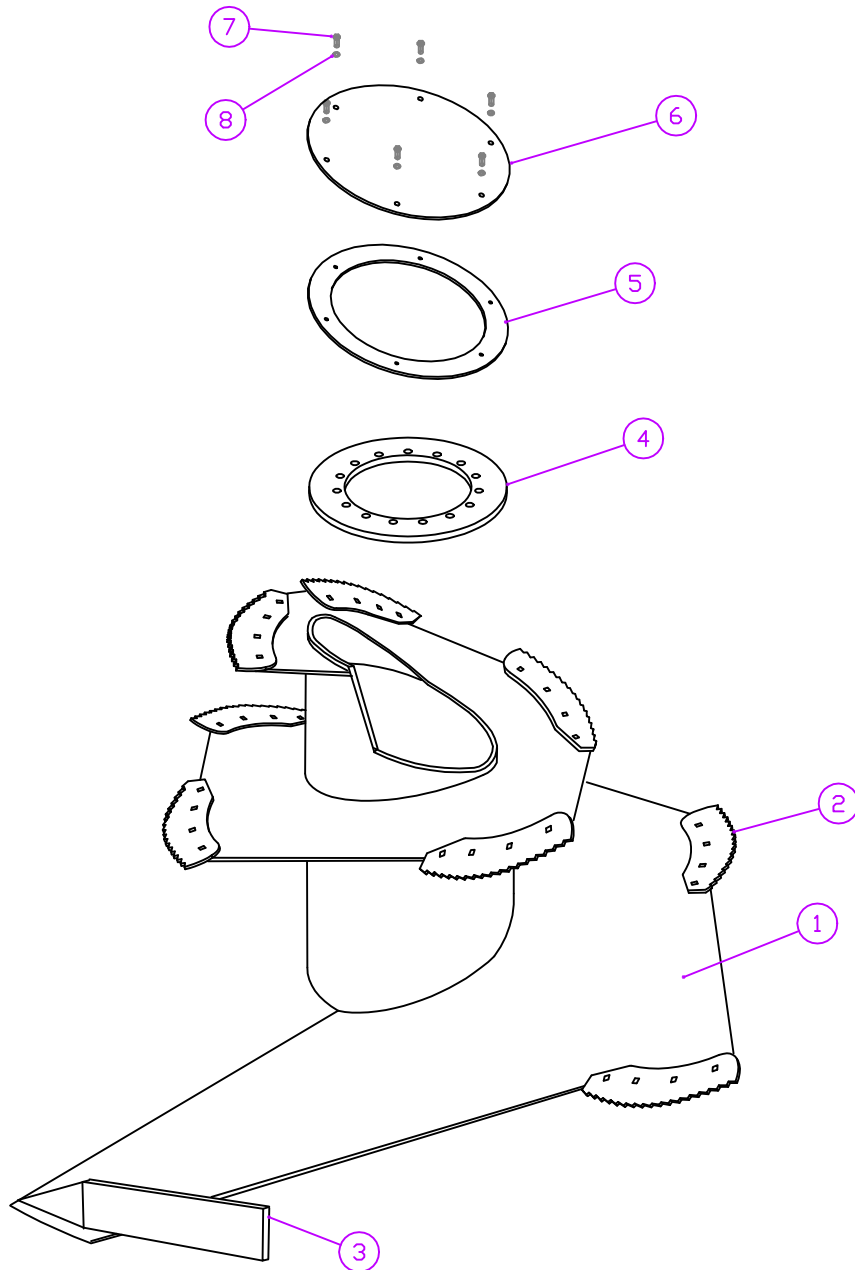

NO.	PART DESC.	QTY	PART NO.
8	Ø3/8" LOCKWASHERS	6	140-00-71
7	Ø3/8" X 1" BOLTS	6	140-00-12
6	AUGER CAP	1	057-00-03
5	SUPPORT RING FOR AUGER CAP	1	057-00-04
4	FASTENING RING	1	050-00-21
3	ANGLING BLADE ASSEMBLY	1	053-07-01
2	KNIFE KIT - 8-PIECE W/ HARDWARE	1	053-06-01
1	BASE MODEL 2300/2350 AUGER	1	053-00-01
NO.	PART DESC.	QTY	PART NO.

PARTS LIST

DRAWN BY: **D. RODGERS** DATE: **AUG 2/00**

MODEL: **2300/2350** SHEET: **1 of 1**

PART/ASSEMBLY NO: **053-05-01**



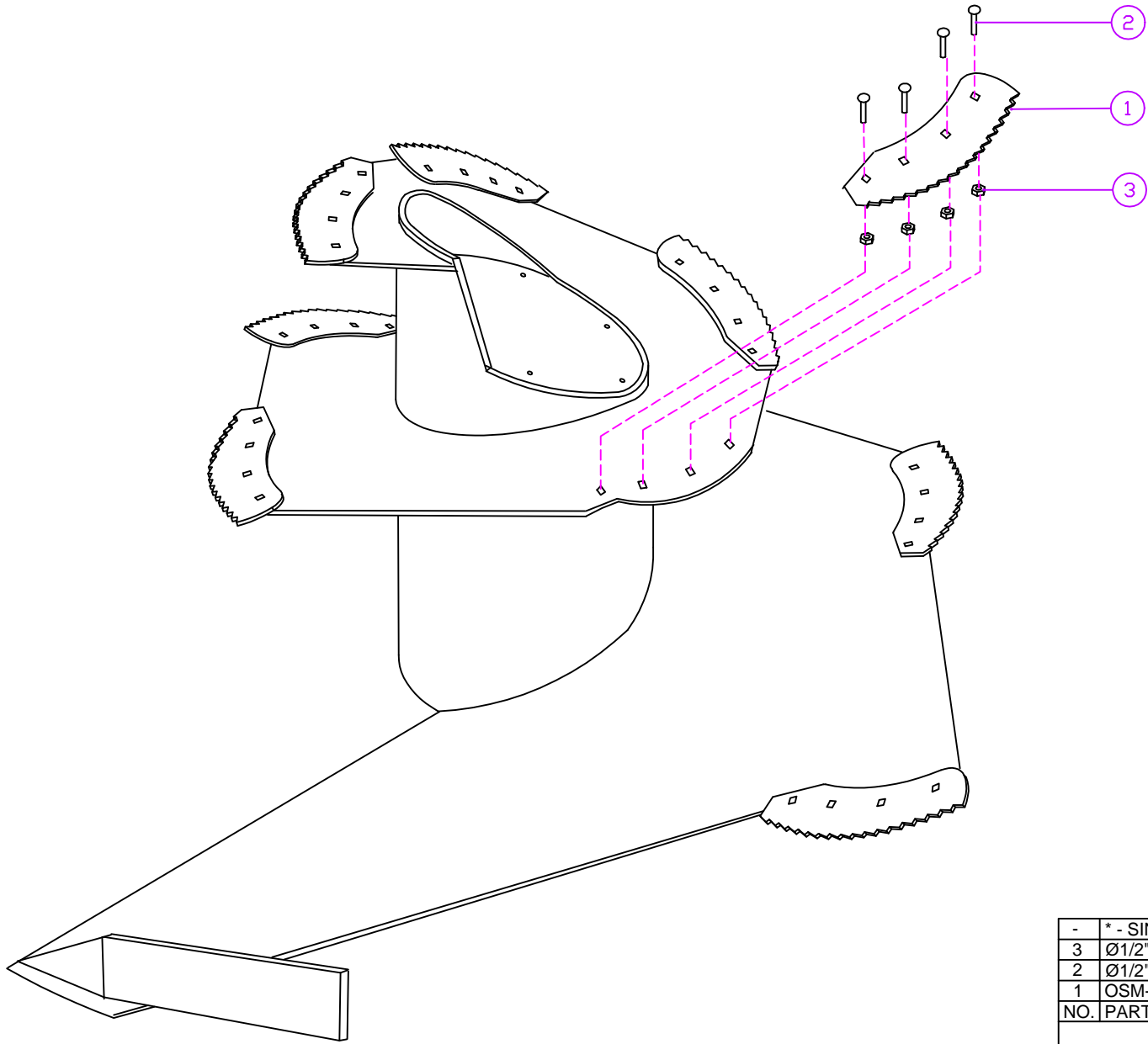

-	* - SINGLE KNIFE ASSEMBLY USE P/N	-	050-06-02
3	Ø1/2" NUTS	32	050-00-12
2	Ø1/2" X 1-1/2" CARRIAGE BOLTS	32	050-00-11
1	OSM-22X JAY-LOR CUTTER BLADE 1/4"	8	050-00-13
NO.	PART DESC.	QTY	PART NO.

PARTS LIST

DRAWN BY: D. RODGERS		DATE: AUG 2/00	
MODEL: 2300/2350		SHEET 1 of 1	
PART/ASSEMBLY NO: 053-06-01			



TITLE: KNIFE KIT ASSEMBLY FOR MODELS 2300/2350 AUGER - 2000 SERIES 'A' (SLOPE TOP), 8 PIECES

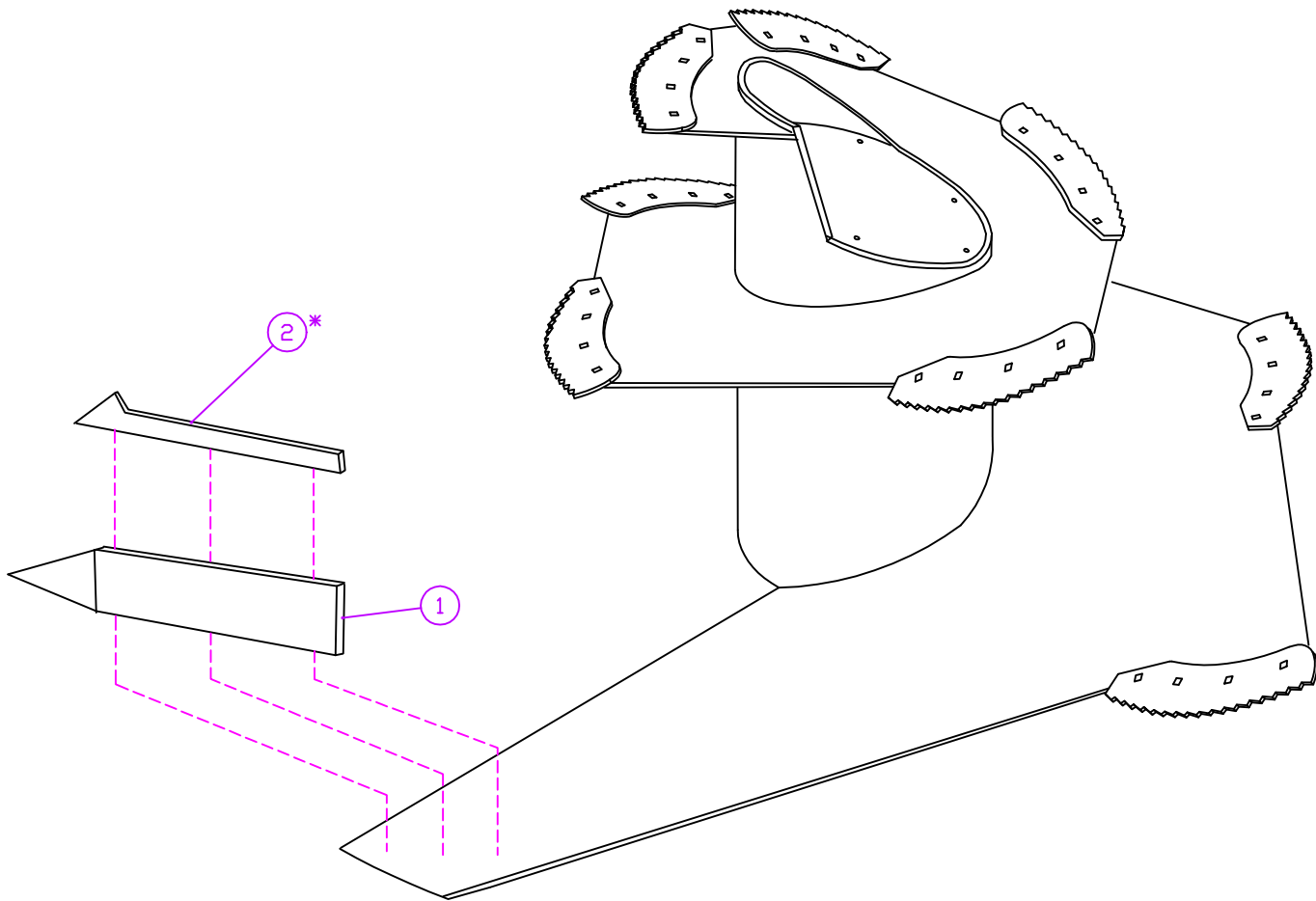

* - SPECIAL USE ONLY

2	ANGLING BLADE EXTENSION*	1	050-00-22
1	ANGLING BLADE	1	050-00-07
NO.	PART DESC.	QTY	PART NO.

PARTS LIST

DRAWN BY: D. RODGERS		DATE: AUG 2/00	
MODEL: 2300/2350		SHEET: 1 of 1	
PART/ASSEMBLY NO.:		053-07-01	



JAY•LOR[®]

Cutter • Mixer • Feeder

06 - CONVEYOR

"Putting the 'Total' into TMR"

JAY-LOR[®] Fabricating Inc.
RR # 2 Orton, Ontario, Canada, L0N 1N0 Tel: (519) 787-9353 Fax: (519) 787-7053

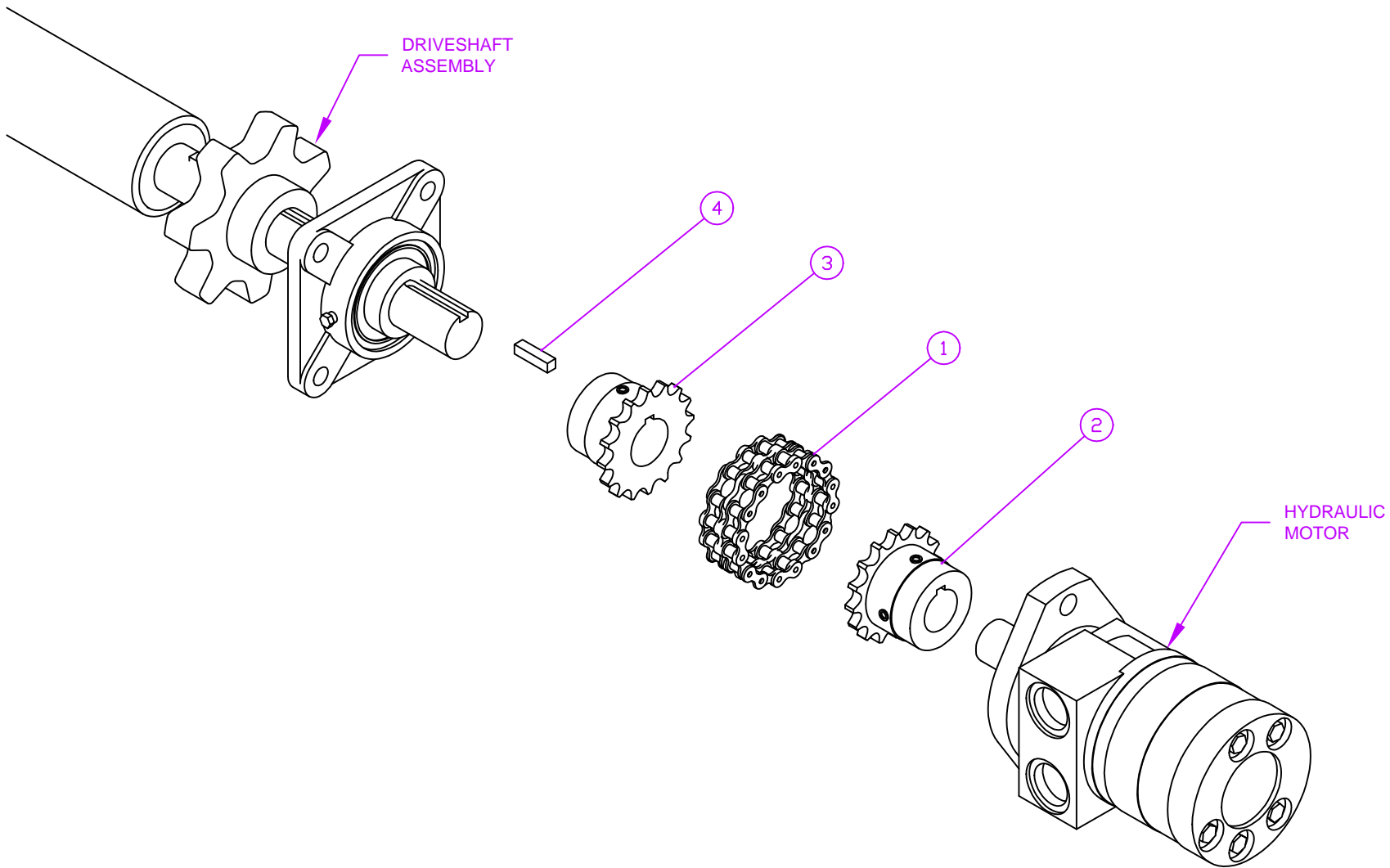

4	KEY	1	060-03-06
3	Ø1-1/8", 16-TOOTH SPROCKET	1	060-03-05
2	Ø1", 16-TOOTH SPROCKET	1	060-03-03
1	CONNECTING CHAIN (#40)	1	060-03-02
NO.	PART DESC.	QTY	PART NO.

PARTS LIST

DRAWN BY: D. RODGERS		DATE: MAY 23/00	
MODEL: ALL APPLICABLE		SHEET: 1 of 1	
PART/ASSEMBLY NO: 060-03-00			



TITLE: CONVEYOR CHAIN COUPLER DRIVE ASSEMBLY

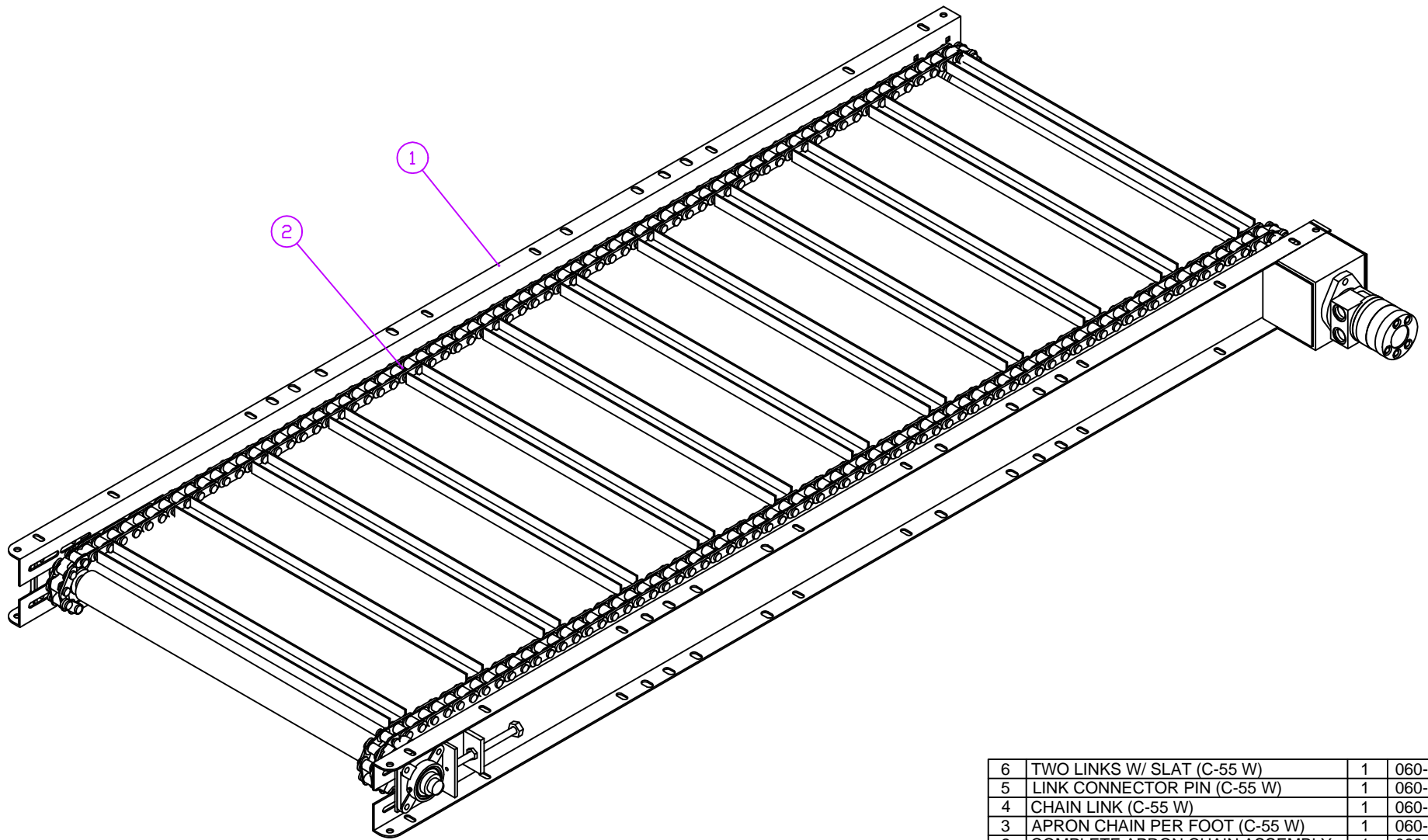

6	TWO LINKS W/ SLAT (C-55 W)	1	060-01-04
5	LINK CONNECTOR PIN (C-55 W)	1	060-01-03
4	CHAIN LINK (C-55 W)	1	060-01-01
3	APRON CHAIN PER FOOT (C-55 W)	1	060-01-00
2	COMPLETE APRON CHAIN ASSEMBLY	1	060-04-05
1	8' (96") DUAL CONVEYOR W/O CHAIN	1	060-04-02
NO.	PART DESC.	QTY	PART NO.

PARTS LIST

DRAWN BY: D. RODGERS	DATE: APR 28/00
MODEL: ALL APPLICABLE	SHEET: 1 of 1
PART/ASSEMBLY NO: 060-04-01	

JAY•LOR
Fabricating Inc

TITLE: 8' (96") DUAL DISCHARGE CONVEYOR ASSEMBLY - COMPLETE W/O SHIELDS AND HOSES

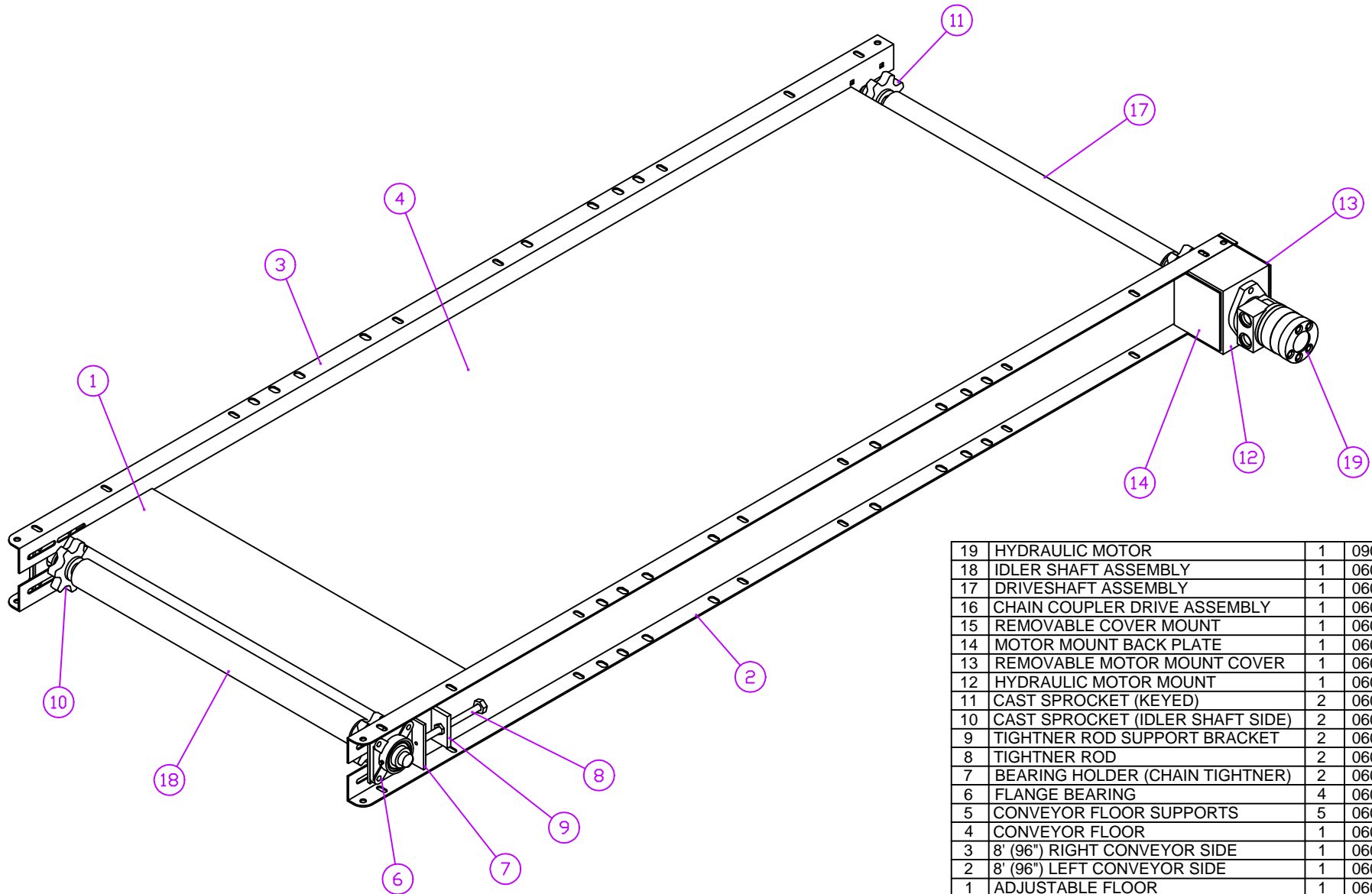

19	HYDRAULIC MOTOR	1	090-00-26
18	IDLER SHAFT ASSEMBLY	1	060-04-09
17	DRIVESHAFT ASSEMBLY	1	060-04-08
16	CHAIN COUPLER DRIVE ASSEMBLY	1	060-03-00
15	REMOVABLE COVER MOUNT	1	060-00-40
14	MOTOR MOUNT BACK PLATE	1	060-00-33
13	REMOVABLE MOTOR MOUNT COVER	1	060-00-32
12	HYDRAULIC MOTOR MOUNT	1	060-00-31
11	CAST SPROCKET (KEYED)	2	060-00-30
10	CAST SPROCKET (IDLER SHAFT SIDE)	2	060-00-27
9	TIGHTNER ROD SUPPORT BRACKET	2	060-00-23
8	TIGHTNER ROD	2	060-00-22
7	BEARING HOLDER (CHAIN TIGHTNER)	2	060-00-21
6	FLANGE BEARING	4	060-00-20
5	CONVEYOR FLOOR SUPPORTS	5	060-00-18
4	CONVEYOR FLOOR	1	060-00-14
3	8' (96'') RIGHT CONVEYOR SIDE	1	060-00-13
2	8' (96'') LEFT CONVEYOR SIDE	1	060-00-12
1	ADJUSTABLE FLOOR	1	060-00-01
NO.	PART DESC.	QTY	PART NO.

PARTS LIST

DRAWN BY: D. RODGERS		DATE: MAY 23/00	
MODEL: ALL APPLICABLE		SHEET: 1 of 3	
PART/ASSEMBLY NO: 060-04-02			

JAY•LOR
Fabricating Inc

TITLE: 8' (96'') DUAL DISCHARGE CONVEYOR ASSEMBLY: COMPLETE W/O APRON CHAIN, SHIELDS, AND HOSES

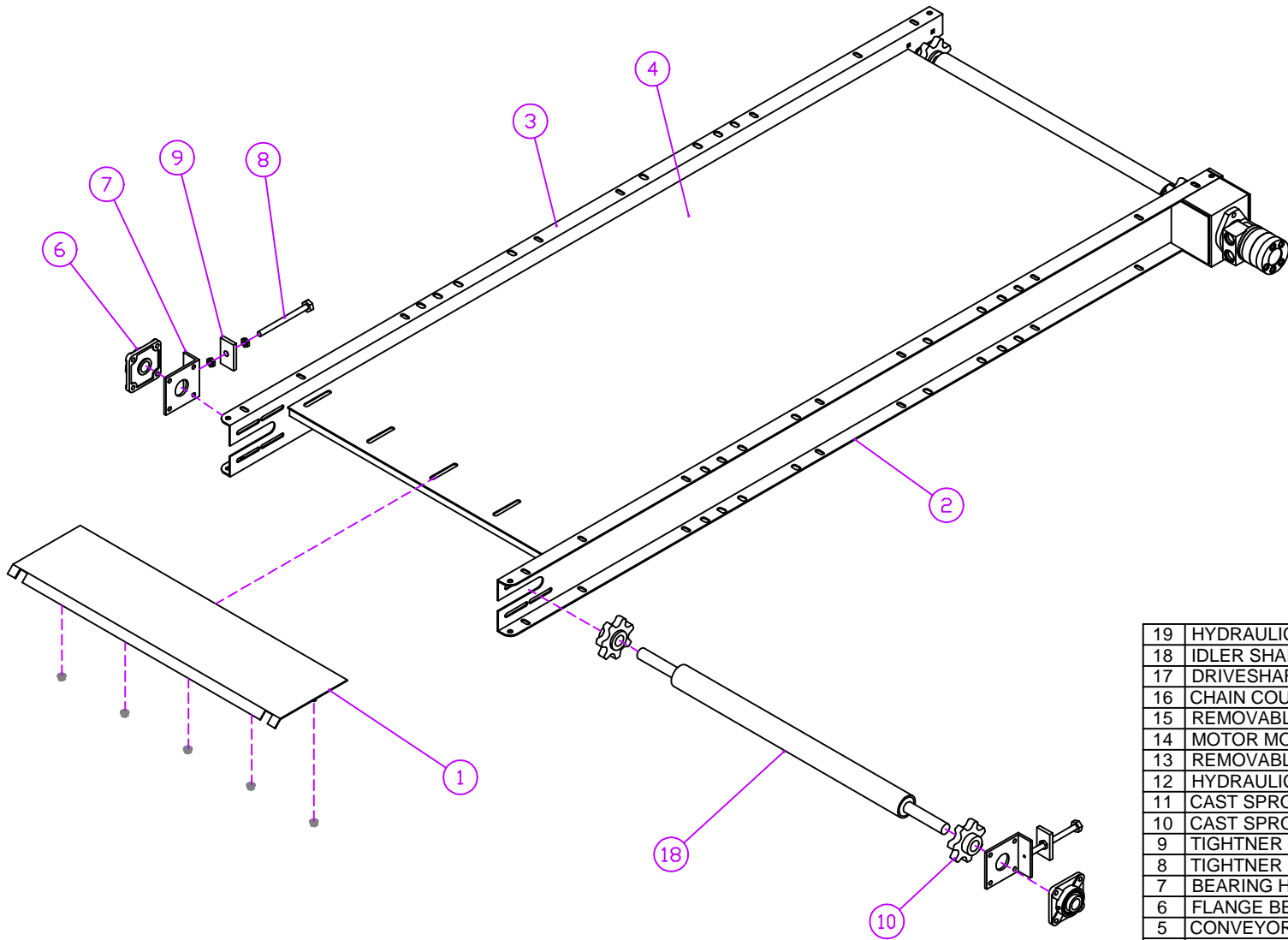

19	HYDRAULIC MOTOR	1	090-00-26
18	IDLER SHAFT ASSEMBLY	1	060-04-09
17	DRIVESHAFT ASSEMBLY	1	060-04-08
16	CHAIN COUPLER DRIVE ASSEMBLY	1	060-03-00
15	REMOVABLE COVER MOUNT	1	060-00-40
14	MOTOR MOUNT BACK PLATE	1	060-00-33
13	REMOVABLE MOTOR MOUNT COVER	1	060-00-32
12	HYDRAULIC MOTOR MOUNT	1	060-00-31
11	CAST SPROCKET (KEYED)	2	060-00-30
10	CAST SPROCKET (IDLER SHAFT SIDE)	2	060-00-27
9	TIGHTNER ROD SUPPORT BRACKET	2	060-00-23
8	TIGHTNER ROD	2	060-00-22
7	BEARING HOLDER (CHAIN TIGHTNER)	2	060-00-21
6	FLANGE BEARING	4	060-00-20
5	CONVEYOR FLOOR SUPPORTS	5	060-00-18
4	CONVEYOR FLOOR	1	060-00-14
3	8' (96") RIGHT CONVEYOR SIDE	1	060-00-13
2	8' (96") LEFT CONVEYOR SIDE	1	060-00-12
1	ADJUSTABLE FLOOR	1	060-00-01
NO.	PART DESC.	QTY	PART NO.

PARTS LIST

DRAWN BY:		DATE:	
D. RODGERS		MAY 23/00	
MODEL:		SHEET:	
ALL APPLICABLE		2 of 3	
PART/ASSEMBLY NO:		060-04-02	

JAY-LOR
Fabricating Inc

TITLE: 8' (96") DUAL DISCHARGE CONVEYOR ASSEMBLY: COMPLETE W/O APRON CHAIN, SHIELDS, AND HOSES

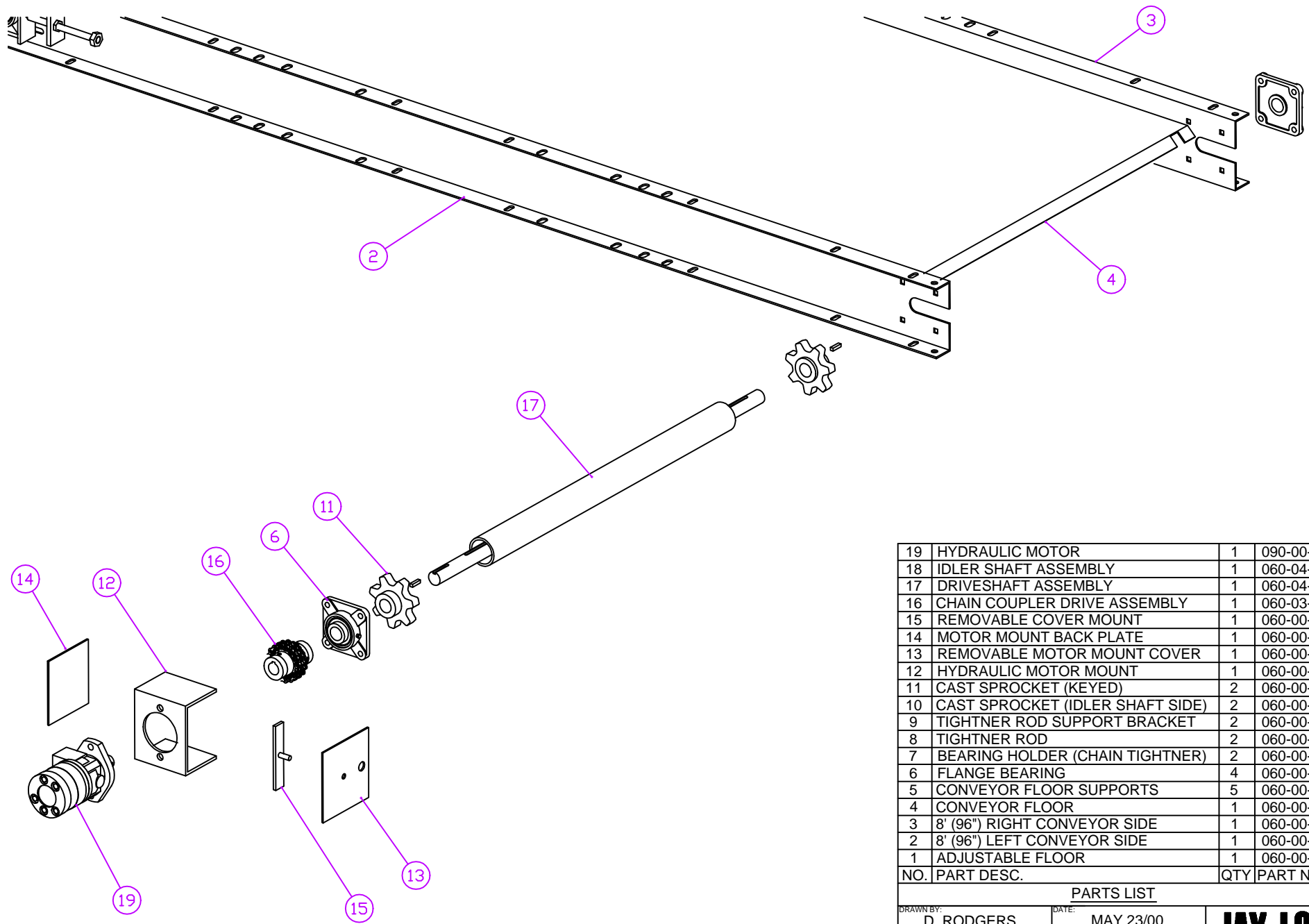

19	HYDRAULIC MOTOR	1	090-00-26
18	IDLER SHAFT ASSEMBLY	1	060-04-09
17	DRIVESHAFT ASSEMBLY	1	060-04-08
16	CHAIN COUPLER DRIVE ASSEMBLY	1	060-03-00
15	REMOVABLE COVER MOUNT	1	060-00-40
14	MOTOR MOUNT BACK PLATE	1	060-00-33
13	REMOVABLE MOTOR MOUNT COVER	1	060-00-32
12	HYDRAULIC MOTOR MOUNT	1	060-00-31
11	CAST SPROCKET (KEYED)	2	060-00-30
10	CAST SPROCKET (IDLER SHAFT SIDE)	2	060-00-27
9	TIGHTNER ROD SUPPORT BRACKET	2	060-00-23
8	TIGHTNER ROD	2	060-00-22
7	BEARING HOLDER (CHAIN TIGHTNER)	2	060-00-21
6	FLANGE BEARING	4	060-00-20
5	CONVEYOR FLOOR SUPPORTS	5	060-00-18
4	CONVEYOR FLOOR	1	060-00-14
3	8' (96") RIGHT CONVEYOR SIDE	1	060-00-13
2	8' (96") LEFT CONVEYOR SIDE	1	060-00-12
1	ADJUSTABLE FLOOR	1	060-00-01
NO.	PART DESC.	QTY	PART NO.

PARTS LIST

DRAWN BY: D. RODGERS	DATE: MAY 23/00
MODEL: ALL APPLICABLE	SHEET: 3 of 3
PART/ASSEMBLY NO: 060-04-02	



TITLE: 8' (96") DUAL DISCHARGE CONVEYOR ASSEMBLY: COMPLETE W/O APRON CHAIN, SHIELDS, AND HOSES

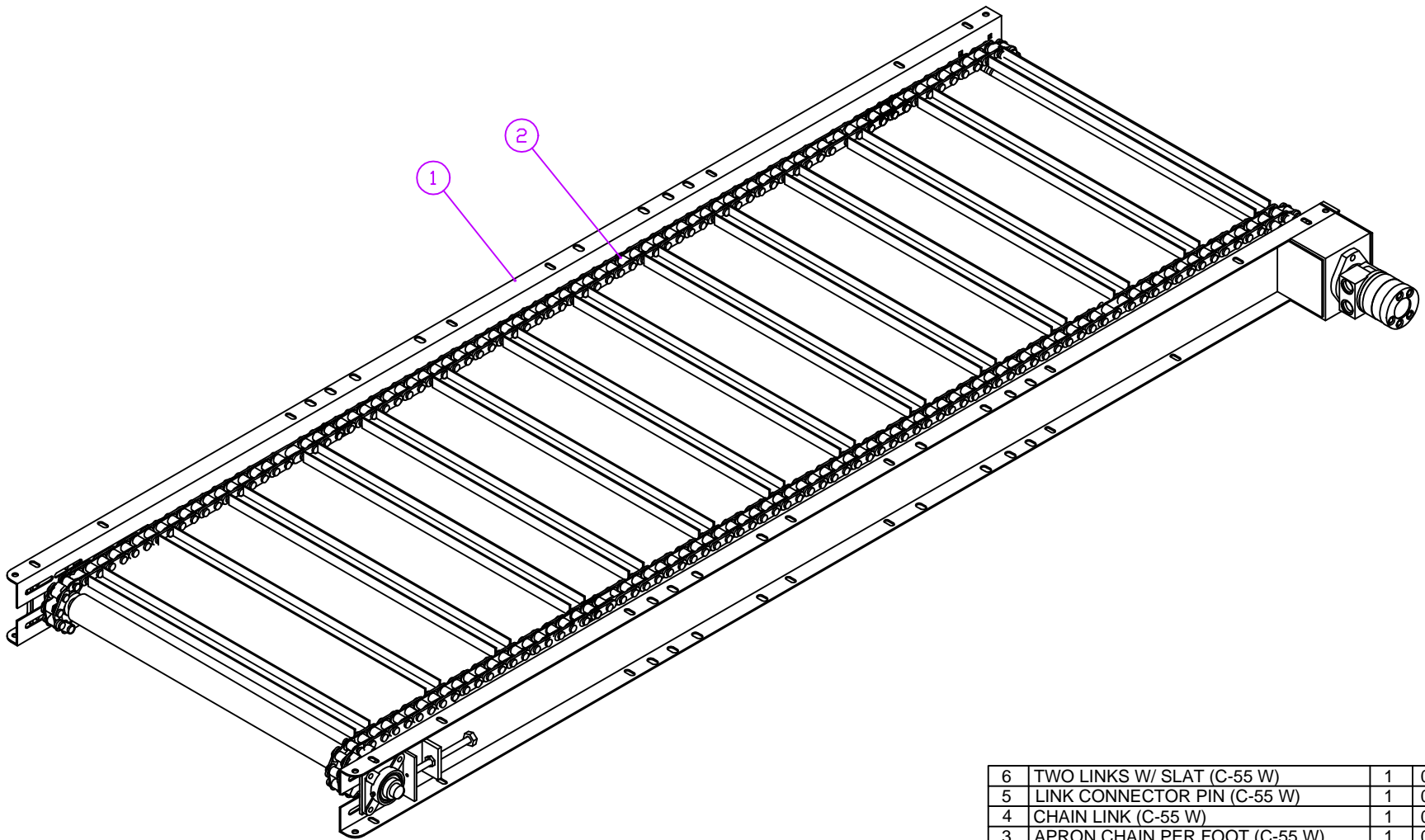

6	TWO LINKS W/ SLAT (C-55 W)	1	060-01-04
5	LINK CONNECTOR PIN (C-55 W)	1	060-01-03
4	CHAIN LINK (C-55 W)	1	060-01-01
3	APRON CHAIN PER FOOT (C-55 W)	1	060-01-00
2	COMPLETE APRON CHAIN ASSEMBLY	1	060-05-05
1	9'-2" DUAL CONVEYOR W/O CHAIN	1	060-05-02
NO.	PART DESC.	QTY	PART NO.

PARTS LIST

DRAWN BY: D. RODGERS	DATE: MAY 25/00
MODEL: ALL APPLICABLE	SHEET: 1 of 1
PART/ASSEMBLY NO: 060-05-01	

JAY•LOR
Fabricating Inc

TITLE: 9'-2" (110") DUAL DISCHARGE CONVEYOR ASSEMBLY - COMPLETE W/O SHIELDS AND HOSES

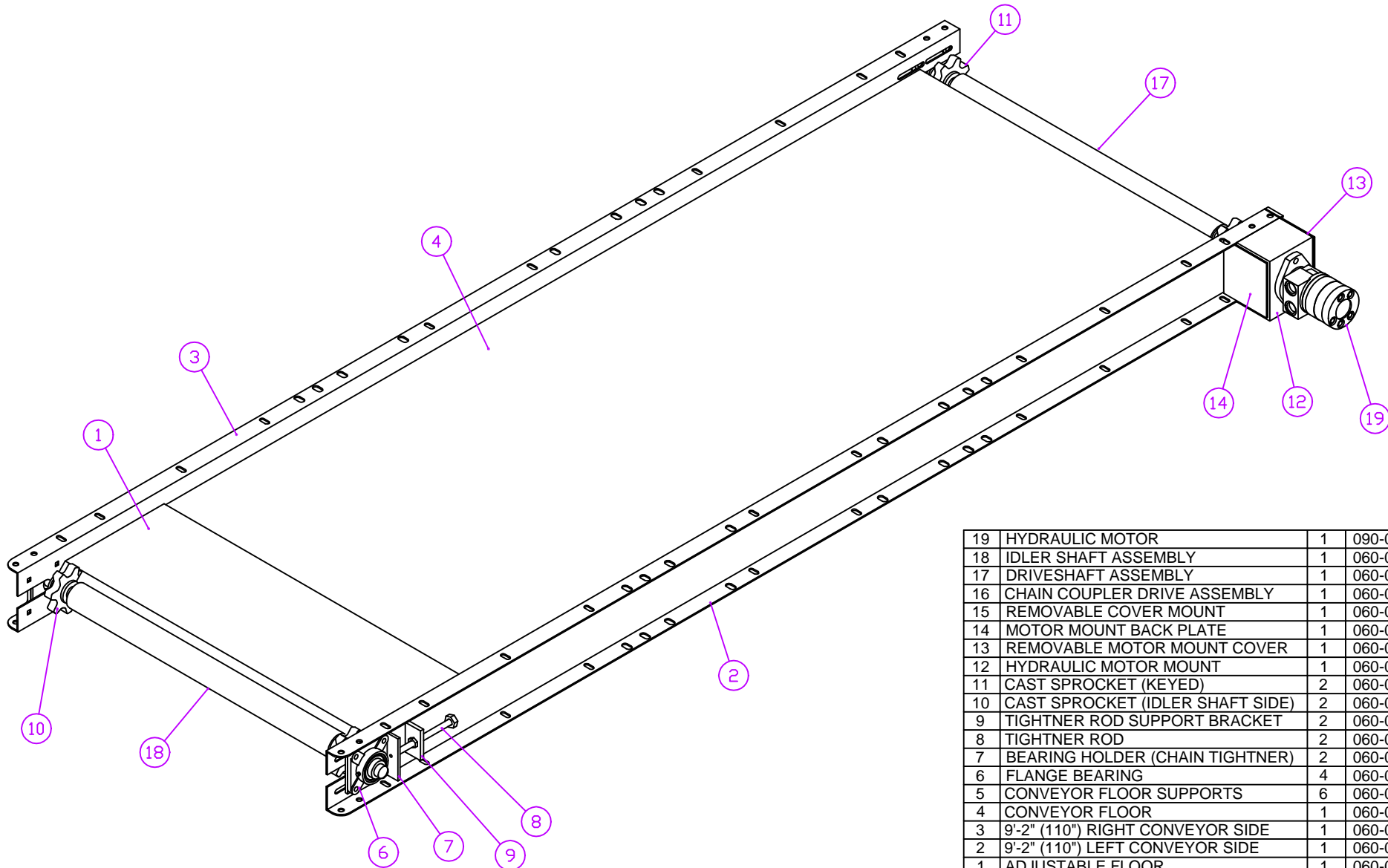

19	HYDRAULIC MOTOR	1	090-00-26
18	IDLER SHAFT ASSEMBLY	1	060-04-09
17	DRIVESHAFT ASSEMBLY	1	060-04-08
16	CHAIN COUPLER DRIVE ASSEMBLY	1	060-03-00
15	REMOVABLE COVER MOUNT	1	060-00-40
14	MOTOR MOUNT BACK PLATE	1	060-00-33
13	REMOVABLE MOTOR MOUNT COVER	1	060-00-32
12	HYDRAULIC MOTOR MOUNT	1	060-00-31
11	CAST SPROCKET (KEYED)	2	060-00-30
10	CAST SPROCKET (IDLER SHAFT SIDE)	2	060-00-27
9	TIGHTNER ROD SUPPORT BRACKET	2	060-00-23
8	TIGHTNER ROD	2	060-00-22
7	BEARING HOLDER (CHAIN TIGHTNER)	2	060-00-21
6	FLANGE BEARING	4	060-00-20
5	CONVEYOR FLOOR SUPPORTS	6	060-00-18
4	CONVEYOR FLOOR	1	060-00-17
3	9'-2" (110") RIGHT CONVEYOR SIDE	1	060-00-16
2	9'-2" (110") LEFT CONVEYOR SIDE	1	060-00-15
1	ADJUSTABLE FLOOR	1	060-00-56
NO.	PART DESC.	QTY	PART NO.

PARTS LIST

DRAWN BY: D. RODGERS		DATE: MAY 25/00	
MODEL: ALL APPLICABLE		SHEET: 1 of 3	
PART/ASSEMBLY NO: 060-05-02			

JAY•LOR
Fabricating Inc

TITLE: 9'-2" (110") DUAL DISCHARGE CONVEYOR ASSEMBLY: COMPLETE W/O APRON CHAIN, SHIELDS, AND HOSES

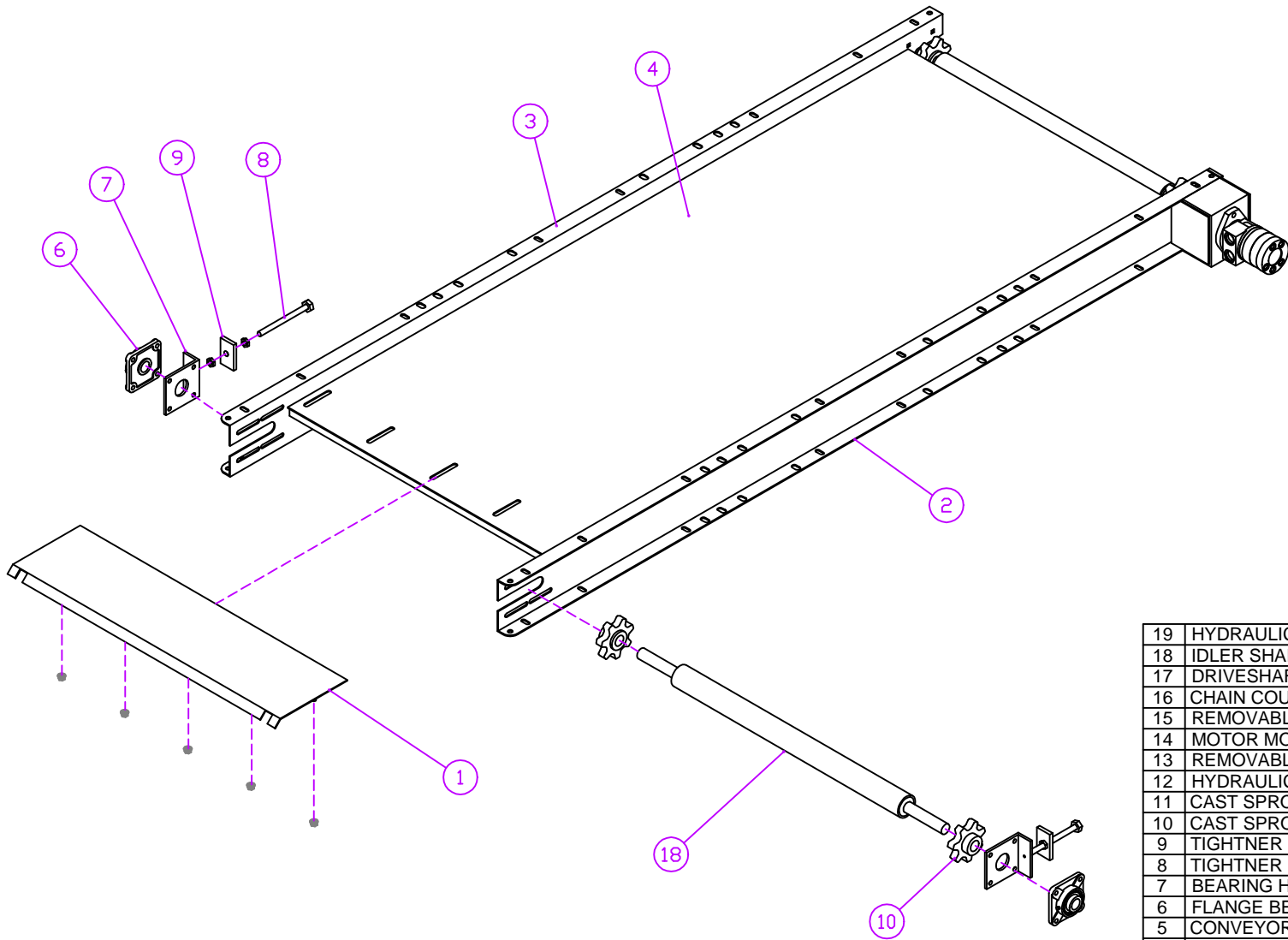

19	HYDRAULIC MOTOR	1	090-00-26
18	IDLER SHAFT ASSEMBLY	1	060-04-09
17	DRIVESHAFT ASSEMBLY	1	060-04-08
16	CHAIN COUPLER DRIVE ASSEMBLY	1	060-03-00
15	REMOVABLE COVER MOUNT	1	060-00-40
14	MOTOR MOUNT BACK PLATE	1	060-00-33
13	REMOVABLE MOTOR MOUNT COVER	1	060-00-32
12	HYDRAULIC MOTOR MOUNT	1	060-00-31
11	CAST SPROCKET (KEYED)	2	060-00-30
10	CAST SPROCKET (IDLER SHAFT SIDE)	2	060-00-27
9	TIGHTNER ROD SUPPORT BRACKET	2	060-00-23
8	TIGHTNER ROD	2	060-00-22
7	BEARING HOLDER (CHAIN TIGHTNER)	2	060-00-21
6	FLANGE BEARING	4	060-00-20
5	CONVEYOR FLOOR SUPPORTS	6	060-00-18
4	CONVEYOR FLOOR	1	060-00-17
3	9'-2" (110") RIGHT CONVEYOR SIDE	1	060-00-16
2	9'-2" (110") LEFT CONVEYOR SIDE	1	060-00-15
1	ADJUSTABLE FLOOR	1	060-00-56
NO.	PART DESC.	QTY	PART NO.

PARTS LIST

DRAWN BY:	D. RODGERS	DATE:	MAY 25/00
MODEL:	ALL APPLICABLE	SHEET:	2 of 3
PART/ASSEMBLY NO.:	060-05-02		

JAY-LOR
Fabricating Inc

TITLE: 9'-2" (110") DUAL DISCHARGE CONVEYOR ASSEMBLY: COMPLETE W/O APRON CHAIN, SHIELDS, AND HOSES

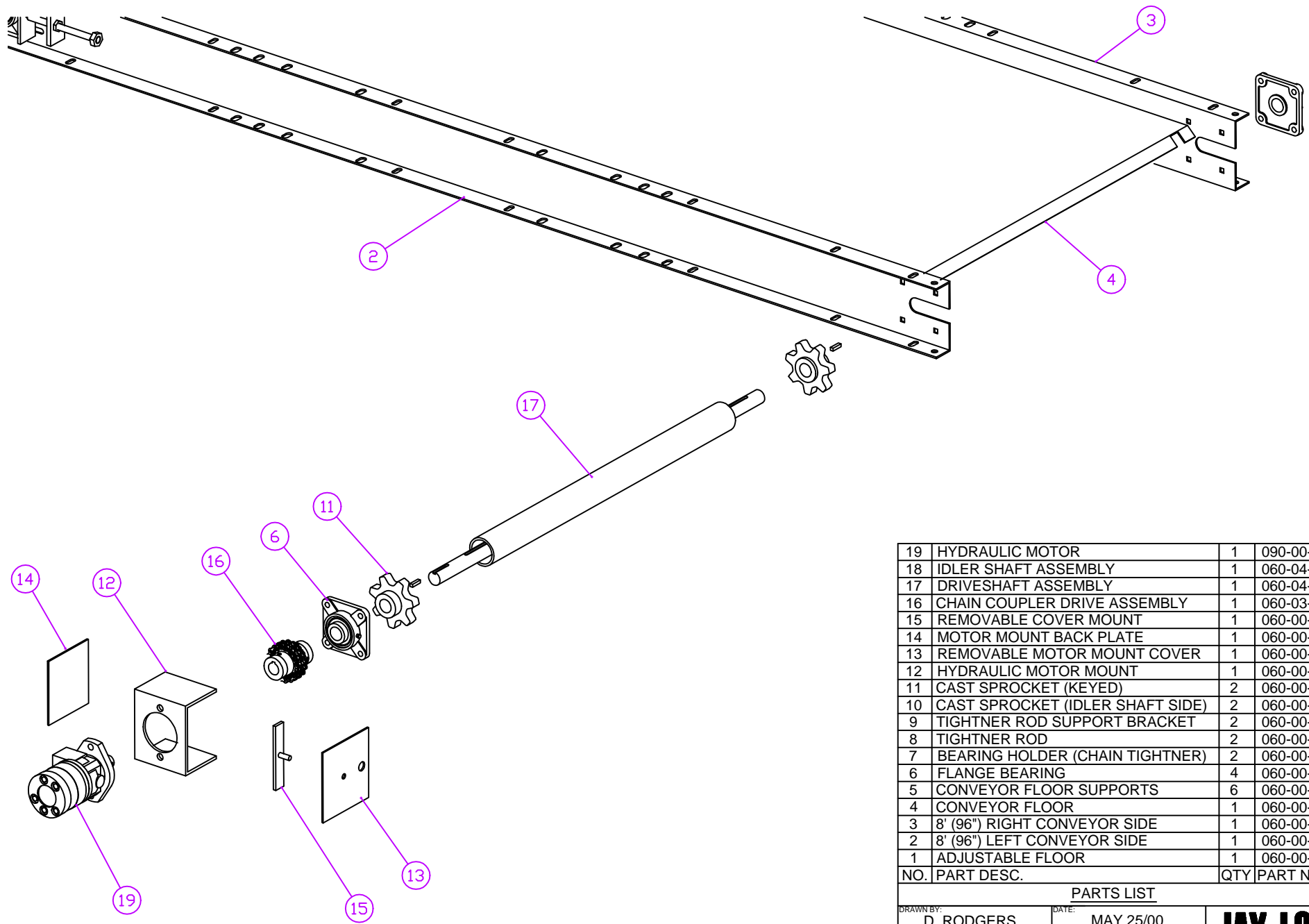

19	HYDRAULIC MOTOR	1	090-00-26
18	IDLER SHAFT ASSEMBLY	1	060-04-09
17	DRIVESHAFT ASSEMBLY	1	060-04-08
16	CHAIN COUPLER DRIVE ASSEMBLY	1	060-03-00
15	REMOVABLE COVER MOUNT	1	060-00-40
14	MOTOR MOUNT BACK PLATE	1	060-00-33
13	REMOVABLE MOTOR MOUNT COVER	1	060-00-32
12	HYDRAULIC MOTOR MOUNT	1	060-00-31
11	CAST SPROCKET (KEYED)	2	060-00-30
10	CAST SPROCKET (IDLER SHAFT SIDE)	2	060-00-27
9	TIGHTNER ROD SUPPORT BRACKET	2	060-00-23
8	TIGHTNER ROD	2	060-00-22
7	BEARING HOLDER (CHAIN TIGHTNER)	2	060-00-21
6	FLANGE BEARING	4	060-00-20
5	CONVEYOR FLOOR SUPPORTS	6	060-00-18
4	CONVEYOR FLOOR	1	060-00-17
3	8' (96") RIGHT CONVEYOR SIDE	1	060-00-16
2	8' (96") LEFT CONVEYOR SIDE	1	060-00-15
1	ADJUSTABLE FLOOR	1	060-00-56
NO.	PART DESC.	QTY	PART NO.

PARTS LIST

DRAWN BY: D. RODGERS	DATE: MAY 25/00
MODEL: ALL APPLICABLE	SHEET: 3 of 3
PART/ASSEMBLY NO: 060-05-02	



TITLE: 9'-2" (110") DUAL DISCHARGE CONVEYOR ASSEMBLY: COMPLETE W/O APRON CHAIN, SHIELDS, AND HOSES

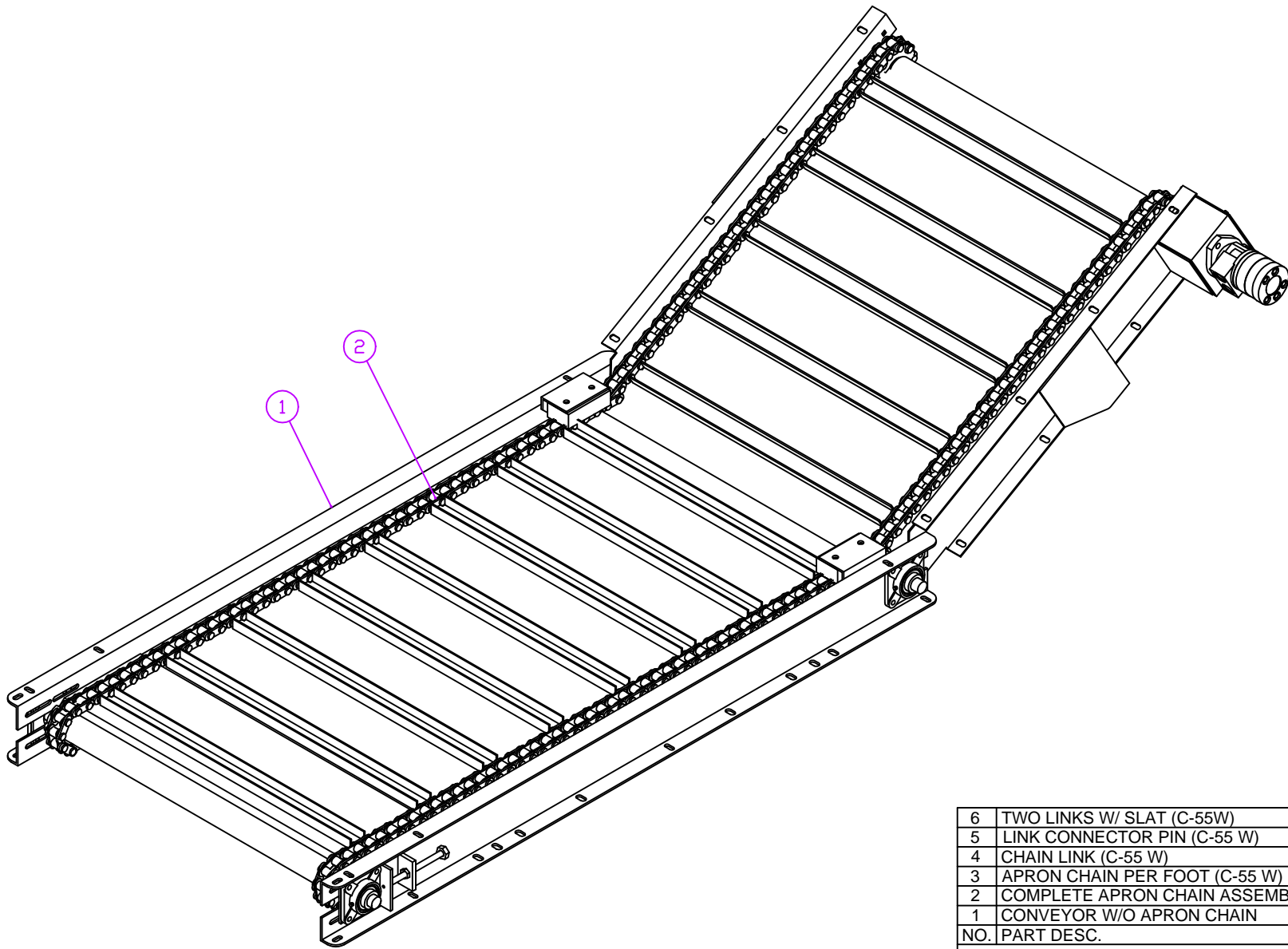

6	TWO LINKS W/ SLAT (C-55W)	1	060-01-04
5	LINK CONNECTOR PIN (C-55 W)	1	060-01-03
4	CHAIN LINK (C-55 W)	1	060-01-01
3	APRON CHAIN PER FOOT (C-55 W)	1	060-01-00
2	COMPLETE APRON CHAIN ASSEMBLY	1	060-08-05
1	CONVEYOR W/O APRON CHAIN	1	060-08-02
NO.	PART DESC.	QTY	PART NO.

PARTS LIST

DRAWN BY: D. RODGERS	DATE: MAY 23/00
MODEL: ALL APPLICABLE	SHEET: 1 of 1
PART/ASSEMBLY NO: 060-08-01	

JAY-LOR
Fabricating Inc

TITLE: 6' CONVEYOR W/ 41" WING EXTENSION: COMPLETE W/O SHIELDS, AND HOSES

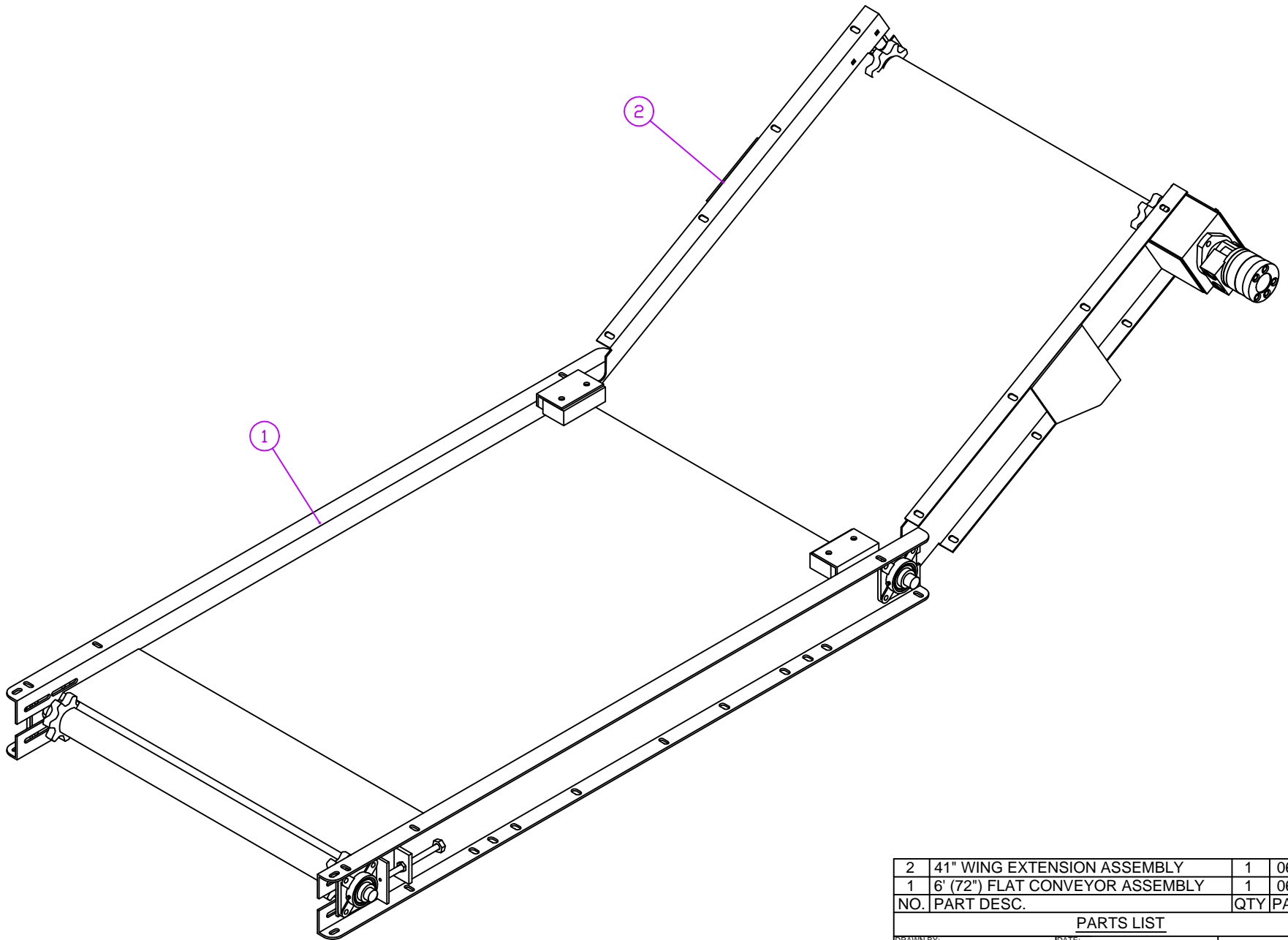

2	41" WING EXTENSION ASSEMBLY	1	060-08-04
1	6' (72") FLAT CONVEYOR ASSEMBLY	1	060-08-03
NO.	PART DESC.	QTY	PART NO.

PARTS LIST

DRAWN BY: D. RODGERS	DATE: MAY 23/00
MODEL: ALL APPLICABLE	SHEET: 1 of 1
PART/ASSEMBLY NO: 060-08-02	



TITLE: 6' CONVEYOR W/ 41" WING EXTENSION: COMPLETE ASSEMBLY W/O APRON CHAIN, SHIELDS, AND HOSES

NOTE:

- 6' FLAT CONVEYOR ASSEMBLY W/ # 060-08-03 SAME AS ASSEMBLY #060-07-03.

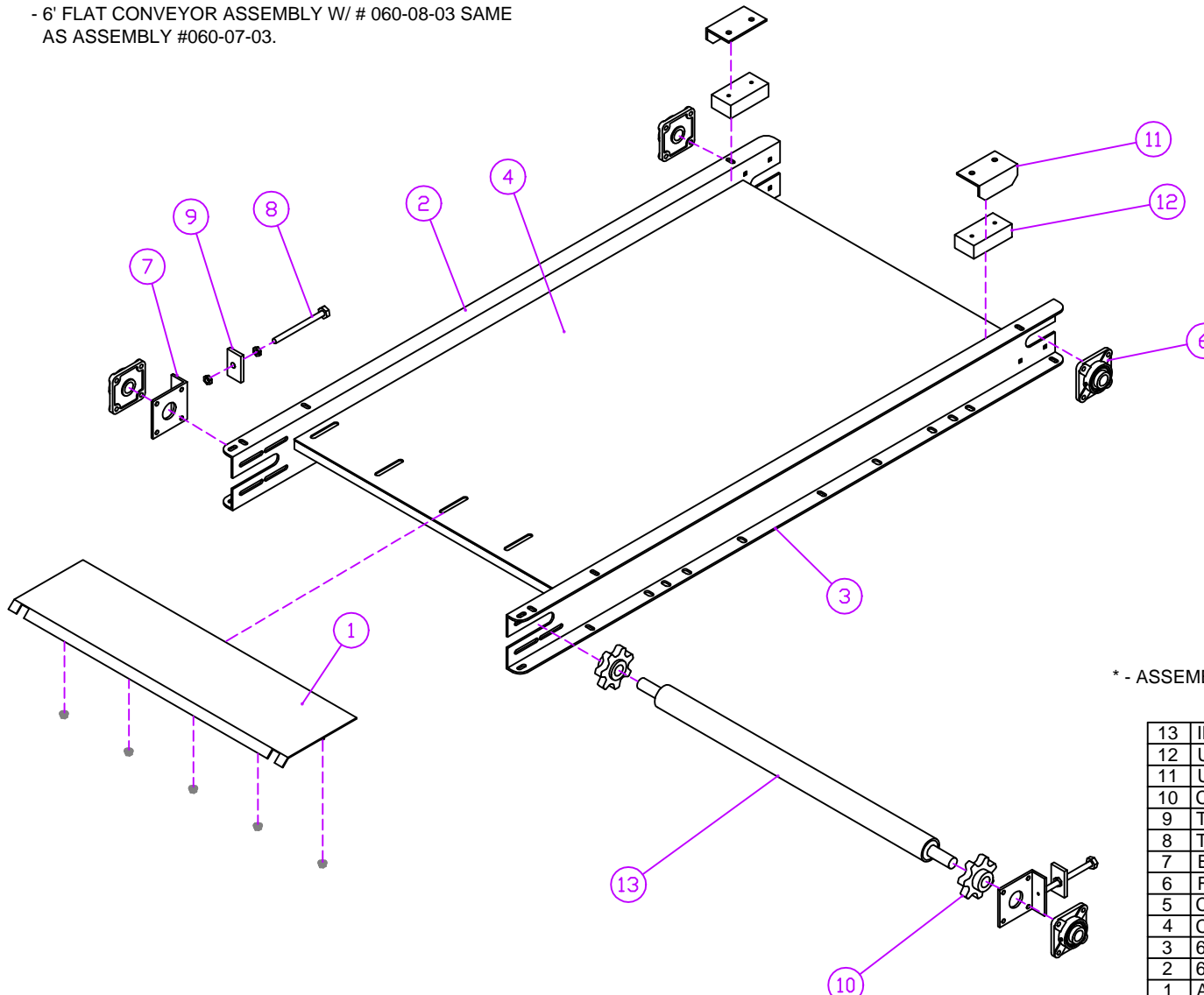

* - ASSEMBLY # 060-08-09 ALSO HAS ASSEMBLY # 060-07-09.

13	IDLER SHAFT ASSEMBLY*	1	060-08-09
12	UPPER TEFLON BLOCK	2	060-00-37
11	UPPER TEFLON BLOCK MOUNT	2	060-00-36
10	CAST SPROCKET (IDLER SHAFT SIDE)	2	060-00-27
9	TIGHTNER ROD SUPPORT BRACKET	2	060-00-23
8	TIGHTNER ROD	2	060-00-22
7	BEARING HOLDER (CHAIN TIGHTNER)	2	060-00-21
6	FLANGE BEARING	4	060-00-20
5	CONVEYOR FLOOR SUPPORTS	5	060-00-18
4	CONVEYOR FLOOR	1	060-00-05
3	6' (72") RIGHT CONVEYOR SIDE	1	060-00-04
2	6' (72") LEFT CONVEYOR SIDE	1	060-00-03
1	ADJUSTABLE FLOOR	1	060-00-01
NO.	PART DESC.	QTY	PART NO.

PARTS LIST

DRAWN BY:		DATE:	
D. RODGERS		MAY 24/00	
MODEL:		SHEET:	
ALL APPLICABLE		1 of 1	
PART/ASSEMBLY NO:		060-08-03	

JAY-LOR
Fabricating Inc

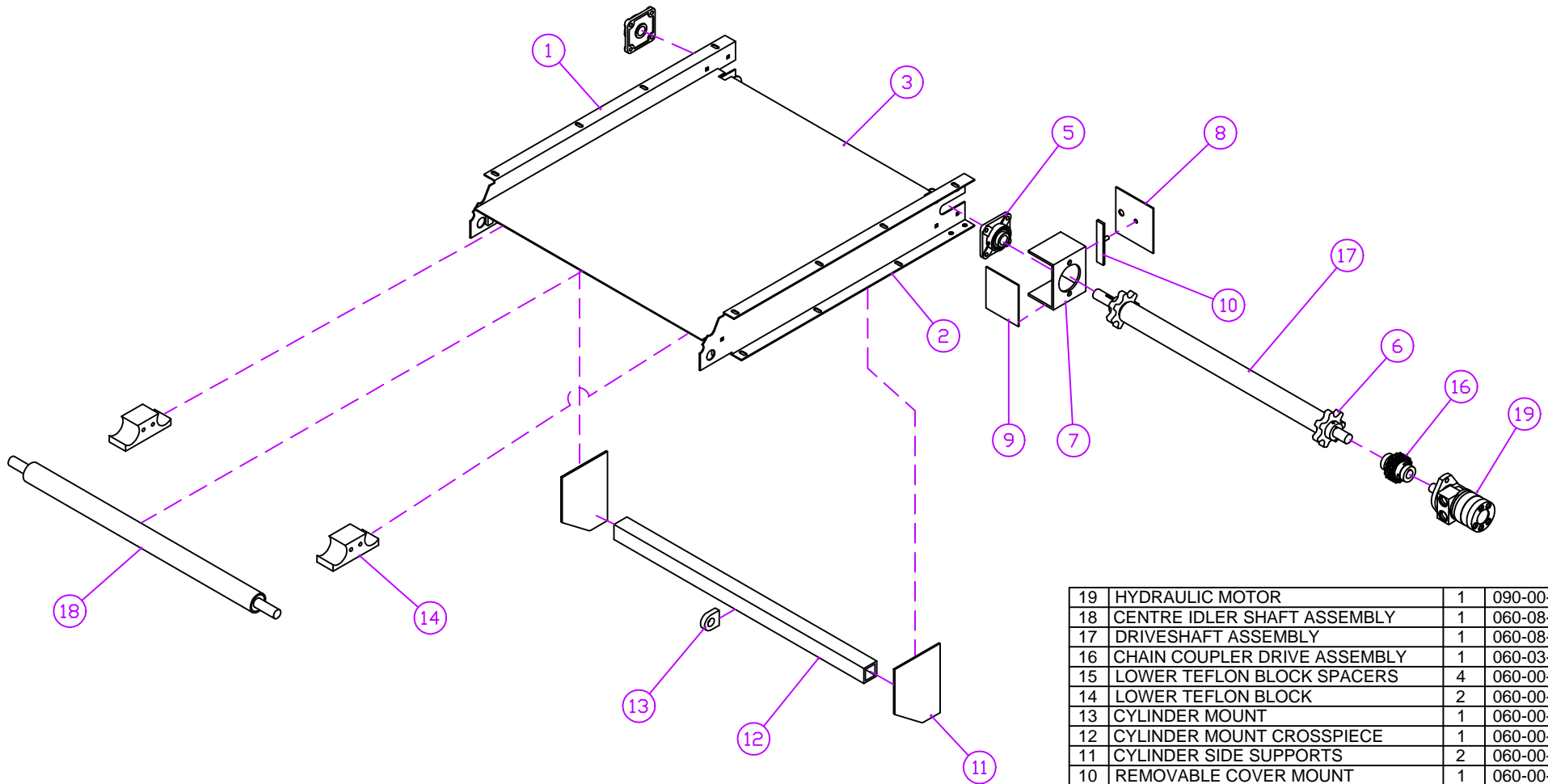

19	HYDRAULIC MOTOR	1	090-00-26
18	CENTRE IDLER SHAFT ASSEMBLY	1	060-08-11
17	DRIVESHAFT ASSEMBLY	1	060-08-08
16	CHAIN COUPLER DRIVE ASSEMBLY	1	060-03-00
15	LOWER TEFLON BLOCK SPACERS	4	060-00-39
14	LOWER TEFLON BLOCK	2	060-00-38
13	CYLINDER MOUNT	1	060-00-41
12	CYLINDER MOUNT CROSSPIECE	1	060-00-35
11	CYLINDER SIDE SUPPORTS	2	060-00-34
10	REMOVABLE COVER MOUNT	1	060-00-40
9	MOTOR MOUNT BACK PLATE	1	060-00-33
8	REMOVABLE MOTOR MOUNT COVER	1	060-00-32
7	HYDRAULIC MOTOR MOUNT	1	060-00-31
6	CAST SPROCKET (KEYED)	2	060-00-30
5	FLANGE BEARING	2	060-00-20
4	CONVEYOR FLOOR SUPPORTS	2	060-00-19
3	WING CONVEYOR FLOOR	1	060-00-08
2	41" RIGHT CONVEYOR SIDE	1	060-00-07
1	41" LEFT CONVEYOR SIDE	1	060-00-06
NO.	PART DESC.	QTY	PART NO.

PARTS LIST

DRAWN BY: D. RODGERS	DATE: MAY 23/00
MODEL: ALL APPLICABLE	SHEET: 1 of 1
PART/ASSEMBLY NO: 060-08-04	

JAY•LOR
Fabricating Inc

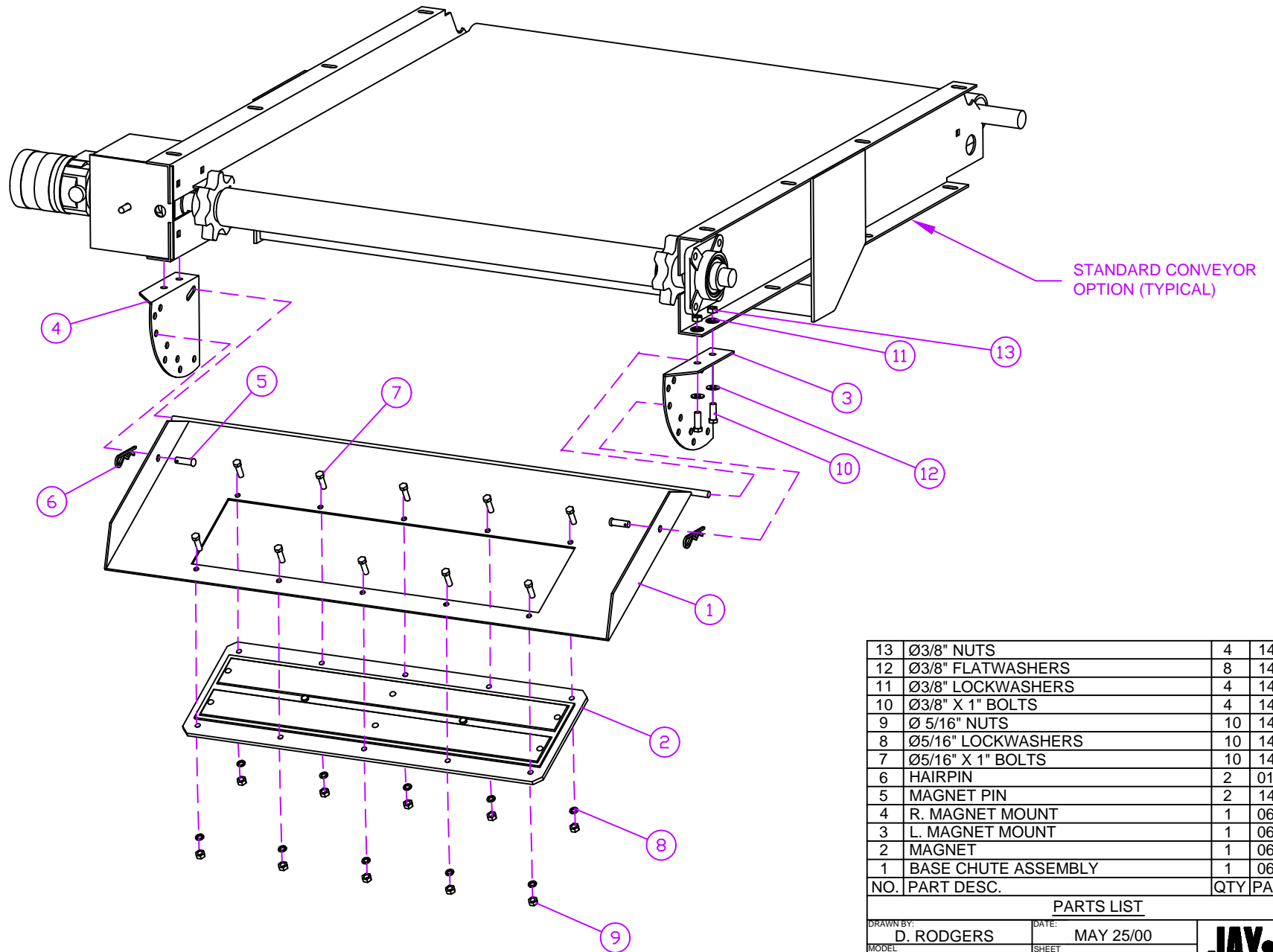

13	Ø3/8" NUTS	4	140-00-85
12	Ø3/8" FLATWASHERS	8	140-00-66
11	Ø3/8" LOCKWASHERS	4	140-00-71
10	Ø3/8" X 1" BOLTS	4	140-00-12
9	Ø 5/16" NUTS	10	140-00-91
8	Ø5/16" LOCKWASHERS	10	140-00-70
7	Ø5/16" X 1" BOLTS	10	140-00-01
6	HAIRPIN	2	010-01-07
5	MAGNET PIN	2	140-00-94
4	R. MAGNET MOUNT	1	060-12-05
3	L. MAGNET MOUNT	1	060-12-04
2	MAGNET	1	060-12-03
1	BASE CHUTE ASSEMBLY	1	060-12-01
NO.	PART DESC.	QTY	PART NO.

PARTS LIST

DRAWN BY:	D. RODGERS	DATE:	MAY 25/00
MODEL:	ALL APPLICABLE	SHEET:	1 of 1
PART/ASSEMBLY NO.:	060-12-00		

JAY•LOR
Fabricating Inc

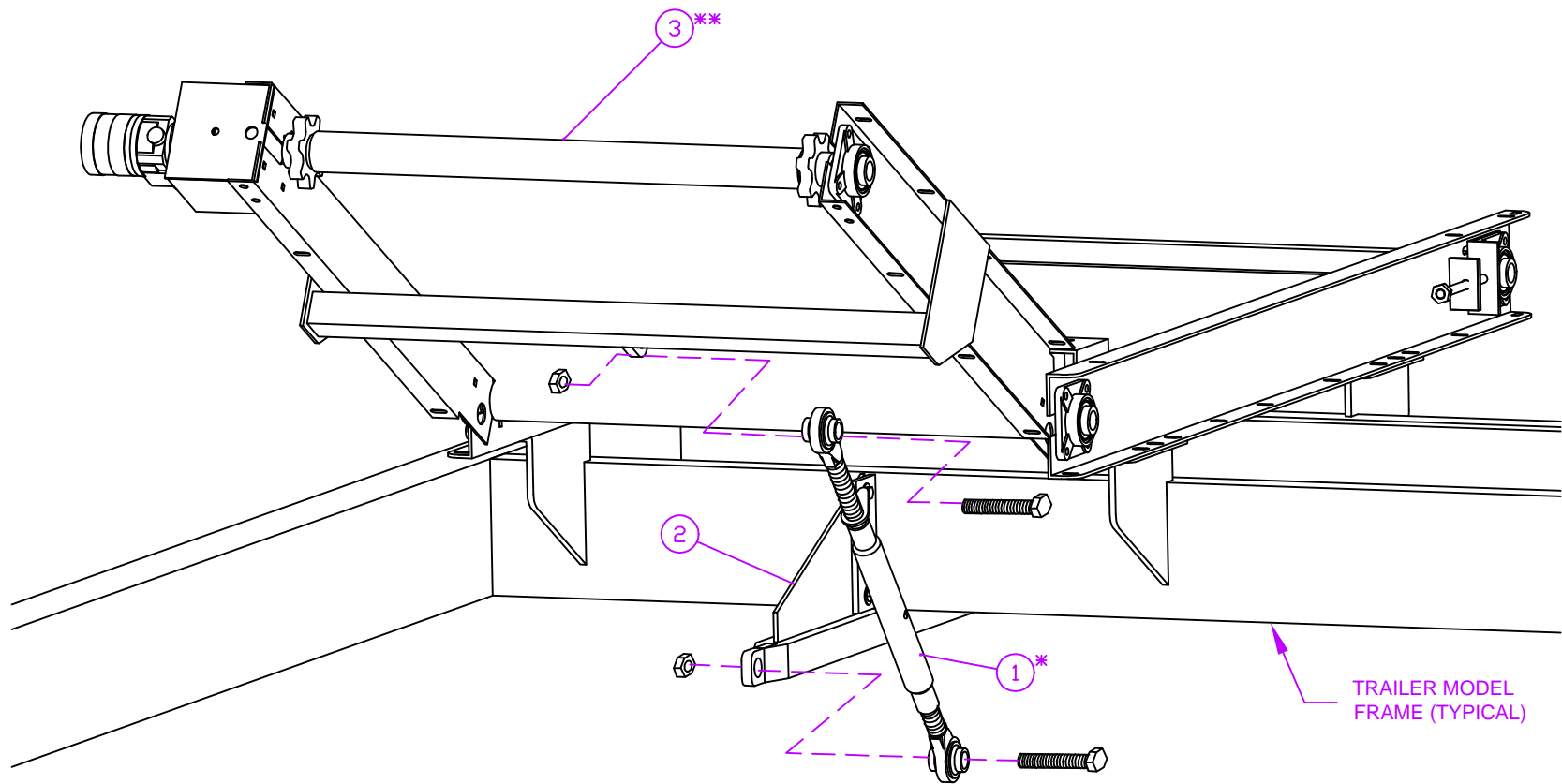

TRAILER MODEL
FRAME (TYPICAL)

- * - INCLUDES MOUNTING HARDWARE
- ** - MANUAL LIFT OPTION AVAILABLE ONLY
W/ 6' CONVEYOR W/ 41" WING EXTENSION.

NO.	PART DESC.	QTY	PART NO.
3	6' CONVEYOR W/ 41" EXTENSION**	1	060-08-01
2	CONVEYOR ATTACHMENT ASSEMBLY	1	025-08-01
1	MANUAL LIFT WING BRACE*	1	060-00-80

PARTS LIST

DRAWN BY: D. RODGERS		DATE: MAY 26/00	
MODEL: 2425		SHEET: 1 of 1	
PART/ASSEMBLY NO:		060-17-00	



TITLE: MANUAL WING CONVEYOR LIFT ASSEMBLY - FOR 6' W/ 41" EXTENSION CONVEYORS W/ DELETION OF HYDRAULIC OPTION.

JAY•LOR[®]

Cutter • Mixer • Feeder

07 - DRIVELINE

"Putting the 'Total' into TMR"

JAY-LOR[®] Fabricating Inc.
RR # 2 Orton, Ontario, Canada, L0N 1N0 Tel: (519) 787-9353 Fax: (519) 787-7053

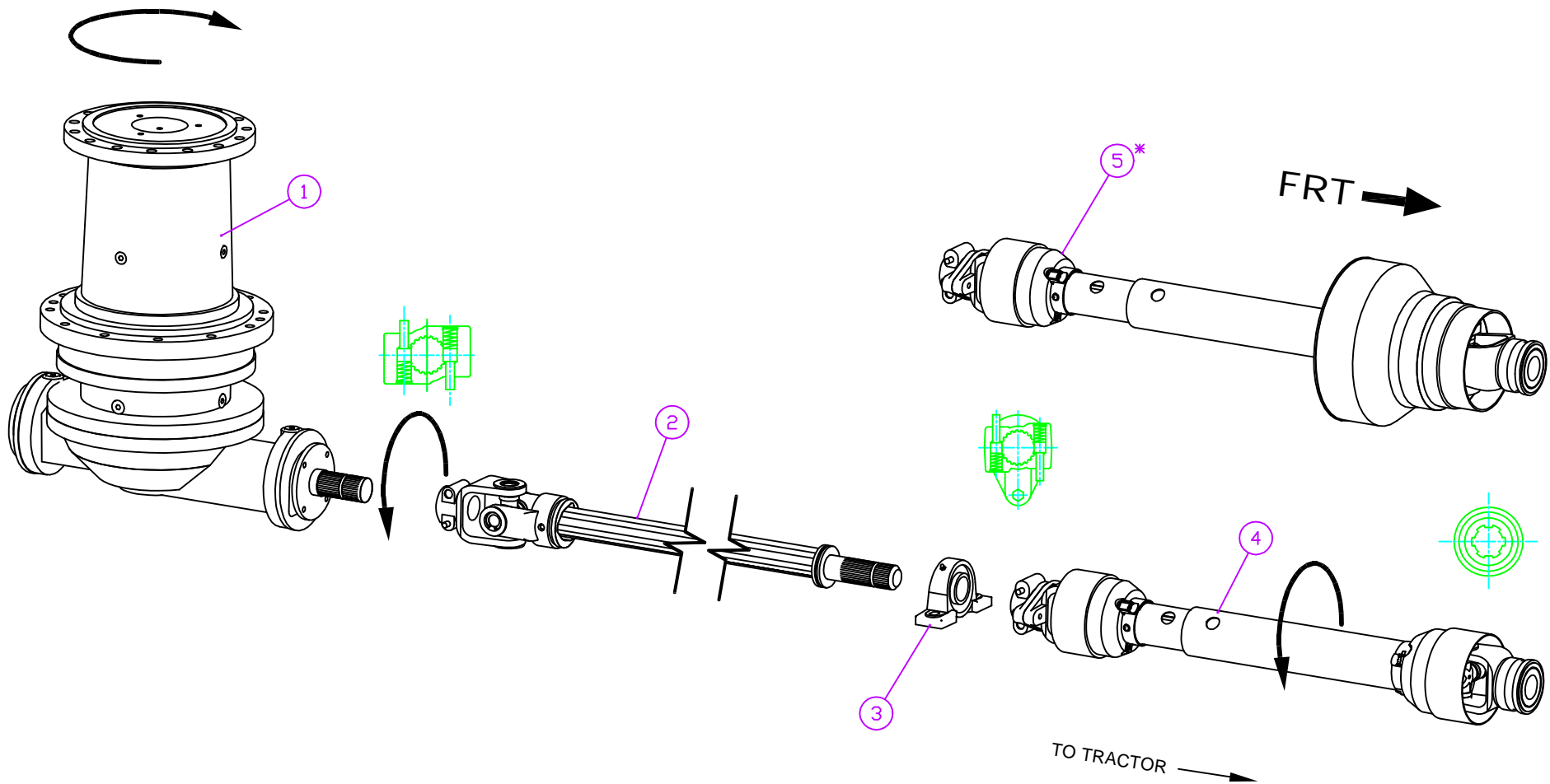

* - ASSEMBLY #070-24-01 OPTION EXTRA, DELETES ASSEMBLY #070-03-01.

5	#8 CV PTO SHAFT (540 RPM) *OPTION*	1	070-24-01
4	#6 STANDARD PTO SHAFT (540 RPM)	1	070-03-01
3	BEARING, PILLOW BLOCK	1	070-00-07
2	#8 DRIVESHAFT ASSEMBLY	1	070-00-10
1	PGA 1602 VM BTI GEARBOX W/ CD 500	1	070-05-01
NO.	PART DESC.	QTY	PART NO.

PARTS LIST

DRAWN BY:	D. RODGERS	DATE:	JUL 27/00
MODEL:	1300/1350	SHEET:	1 of 1

PART/ASSEMBLY NO: 073-05-02

JAY-LOR
Fabricating Inc

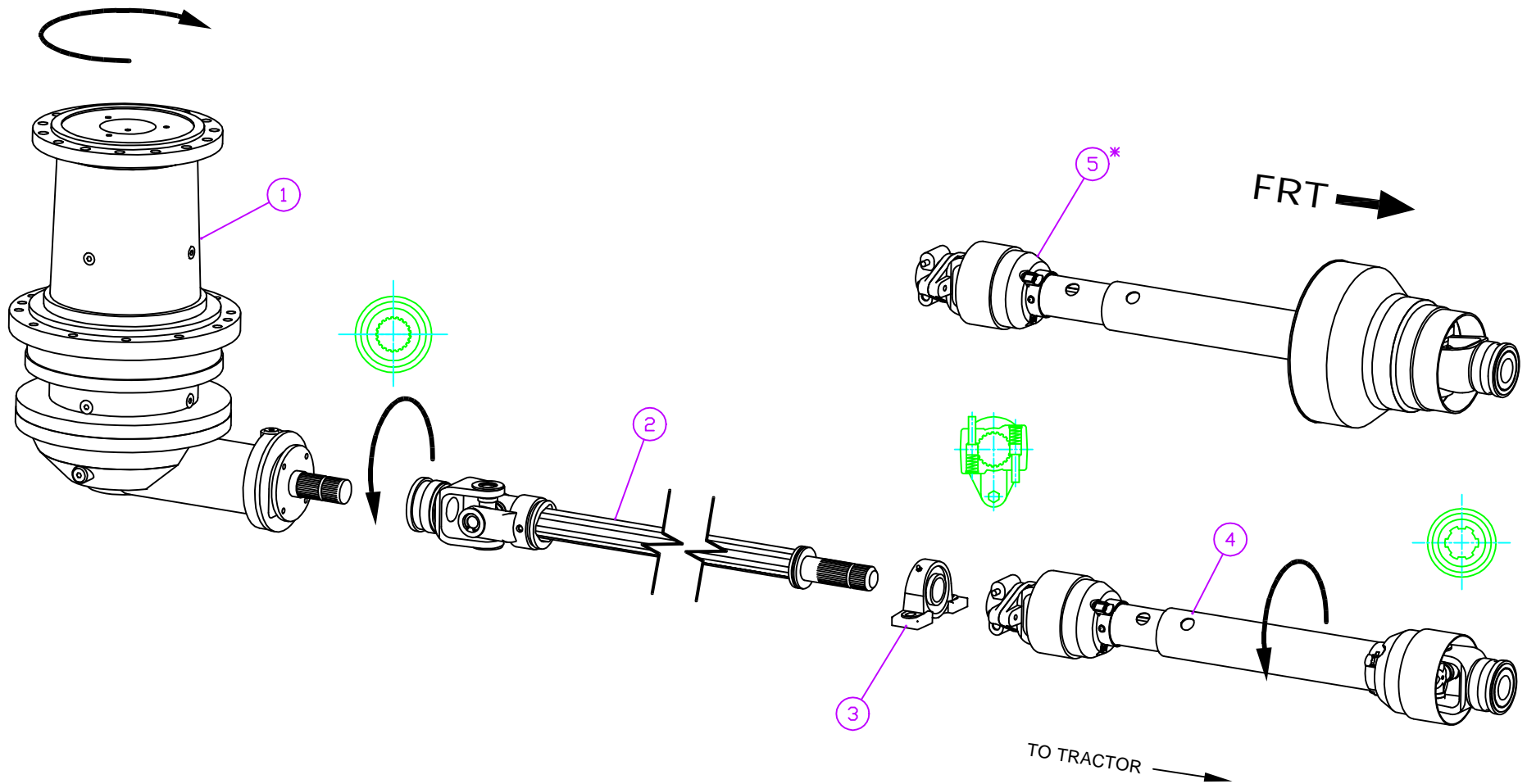

* - ASSEMBLY #070-24-01 OPTION EXTRA, DELETES ASSEMBLY #070-03-01.

5	#8 CV PTO SHAFT (540 RPM) *OPTION*	1	070-24-01
4	#6 STANDARD PTO SHAFT (540 RPM)	1	070-03-01
3	BEARING, PILLOW BLOCK	1	070-00-07
2	#8 DRIVESHAFT ASSEMBLY	1	070-04-00
1	PGA 1602 VM BTI GEARBOX W/ CD 450	1	070-20-01
NO.	PART DESC.	QTY	PART NO.

PARTS LIST

DRAWN BY: D. RODGERS DATE: JUL 27/00

MODEL: 2300/2350 SHEET: 1 of 1

PART/ASSEMBLY NO: 073-05-03

JAY-LOR
Fabricating Inc

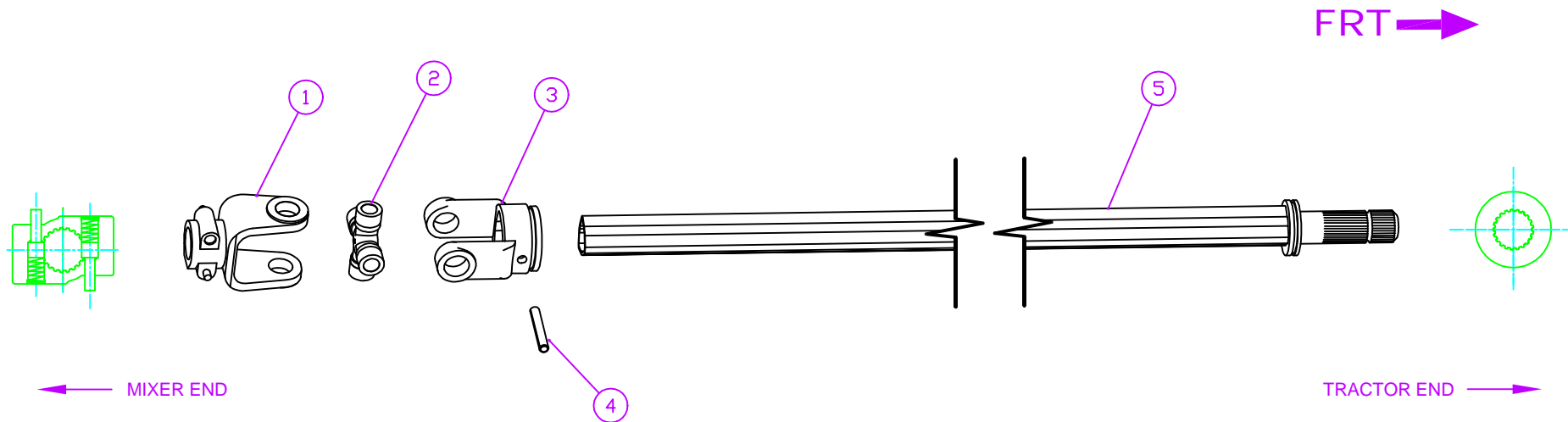

5	#8 DRIVESHAFT W/ SPLINED END	1	070-00-17
4	ROLL PIN FOR OUTER TUBE	1	070-04-04
3	#8 YOKE, TUBE END	1	070-04-03
2	#8 CROSS (35.0mm X 106.5mm)	1	070-04-02
1	#8 YOKE - 1-3/4", 20-SPLINE (PUSH PIN)	1	070-00-35
NO.	PART DESC.	QTY	PART NO.

PARTS LIST

DRAWN BY: D. RODGERS	DATE: MAY 19/00
MODEL: ALL APPLICABLE	SHEET: 1 of 1
PART/ASSEMBLY NO: 070-00-10	

JAY•LOR
Fabricating Inc

TITLE: COMPLETE #8 STANDARD DRIVESHAFT ASSEMBLY - W/ PUSH PIN YOKE (PRE-2000 SERIES)

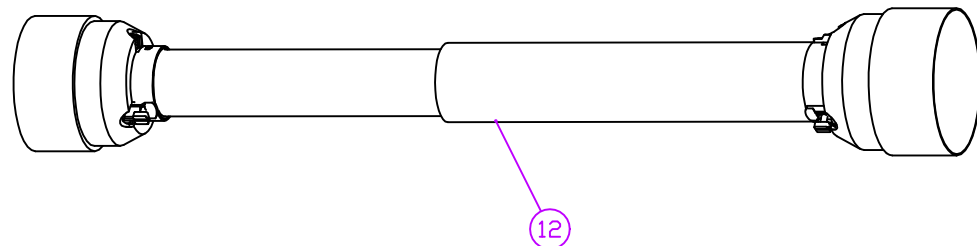
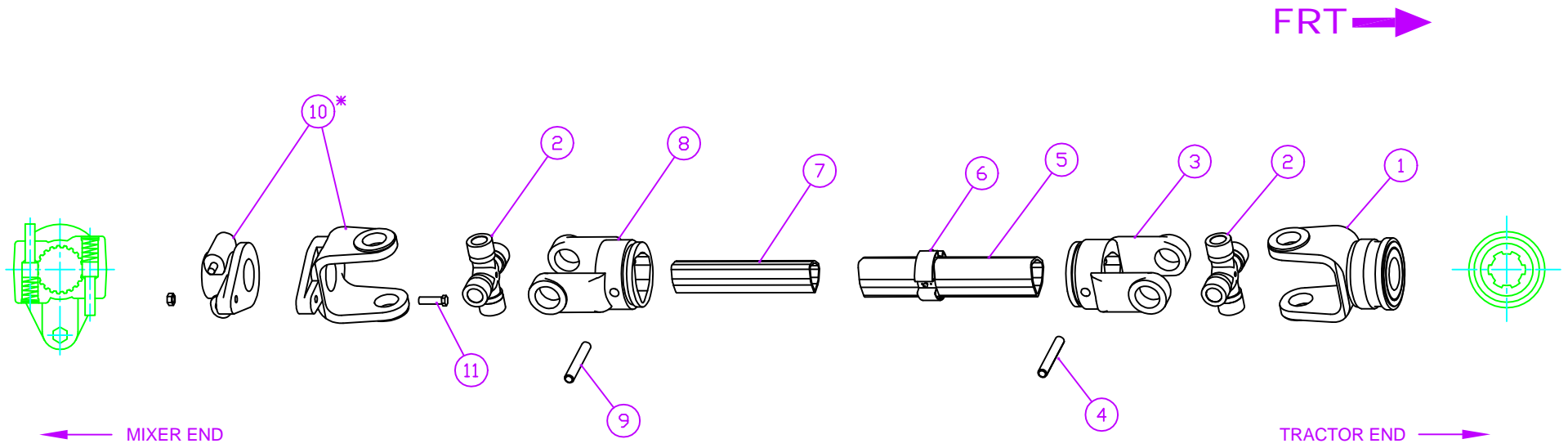

* - SHEAR BOLT YOKE ASSEMBLY

12	#6 PTO SHAFT SHIELD ASSEMBLY	1	070-09-00
11	SHEAR BOLT, 10mm X 60mm, GRD 8.8	1	070-00-73
10	MIXER END YOKE (1-3/4", 20-SPLINE)*	1	070-00-34
9	ROLL PIN FOR INNER TUBE	1	070-00-46
8	#6 YOKE, INNER TUBE, MIXER END	1	070-00-38
7	#6 PTO INNER TUBE (MIXER END)	1	070-00-48
6	BUSHING FOR OUTER TUBE	1	070-00-30
5	#6 PTO OUTER TUBE (TRACTOR END)	1	070-00-47
4	ROLL PIN FOR OUTER TUBE	1	070-00-45
3	#6 YOKE, OUTER TUBE, TRACTOR END	1	070-00-37
2	#6 CROSS (30.2mm X 92.0mm)	2	070-00-19
1	TRACTOR END YOKE (1-3/8", 6-SPLINE)	1	070-00-24
NO.	PART DESC.	QTY	PART NO.

PARTS LIST

DRAWN BY: D. RODGERS	DATE: JUL 19/00
MODEL: ALL APPLICABLE	SHEET: 1 of 1
PART/ASSEMBLY NO: 070-03-01	



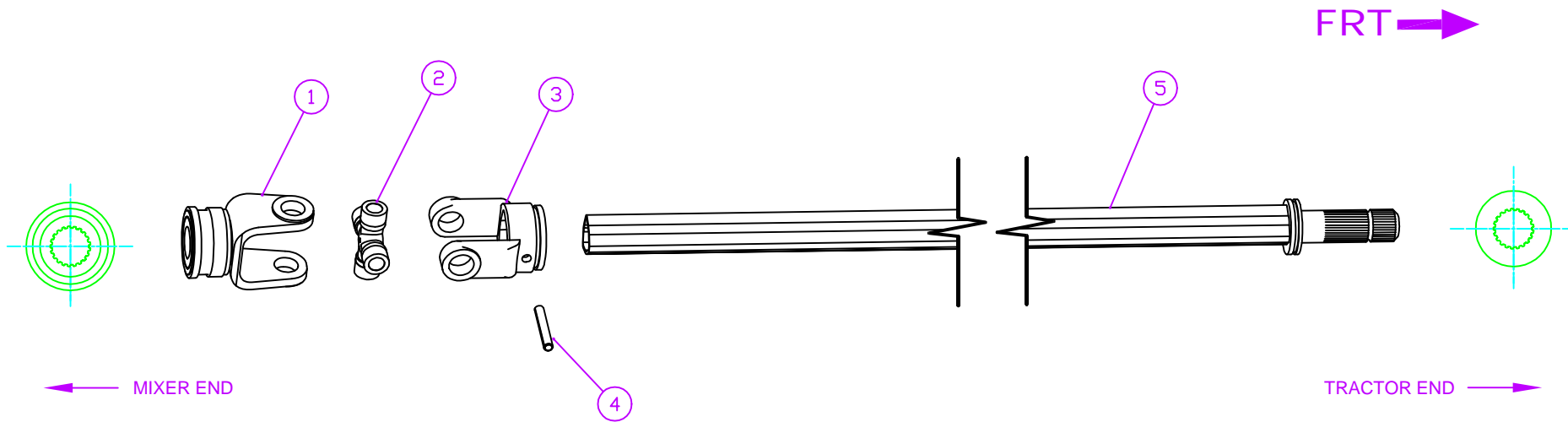

5	#8 DRIVESHAFT W/ SPLINED END	1	070-04-06
4	ROLL PIN FOR OUTER TUBE	1	070-04-04
3	#8 YOKE, TUBE END	1	070-04-03
2	#8 CROSS (35.0mm X 106.5mm)	1	070-04-02
1	#8 YOKE - 1-3/4", 20-SPLINE	1	070-04-01
NO.	PART DESC.	QTY	PART NO.

PARTS LIST

DRAWN BY: D. RODGERS	DATE: MAY 19/00
MODEL: ALL APPLICABLE	SHEET: 1 of 1
PART/ASSEMBLY NO: 070-04-00	

JAY•LOR
Fabricating Inc

TITLE: COMPLETE #8 STANDARD DRIVESHAFT ASSEMBLY - W/ SLIDE COLLAR YOKE

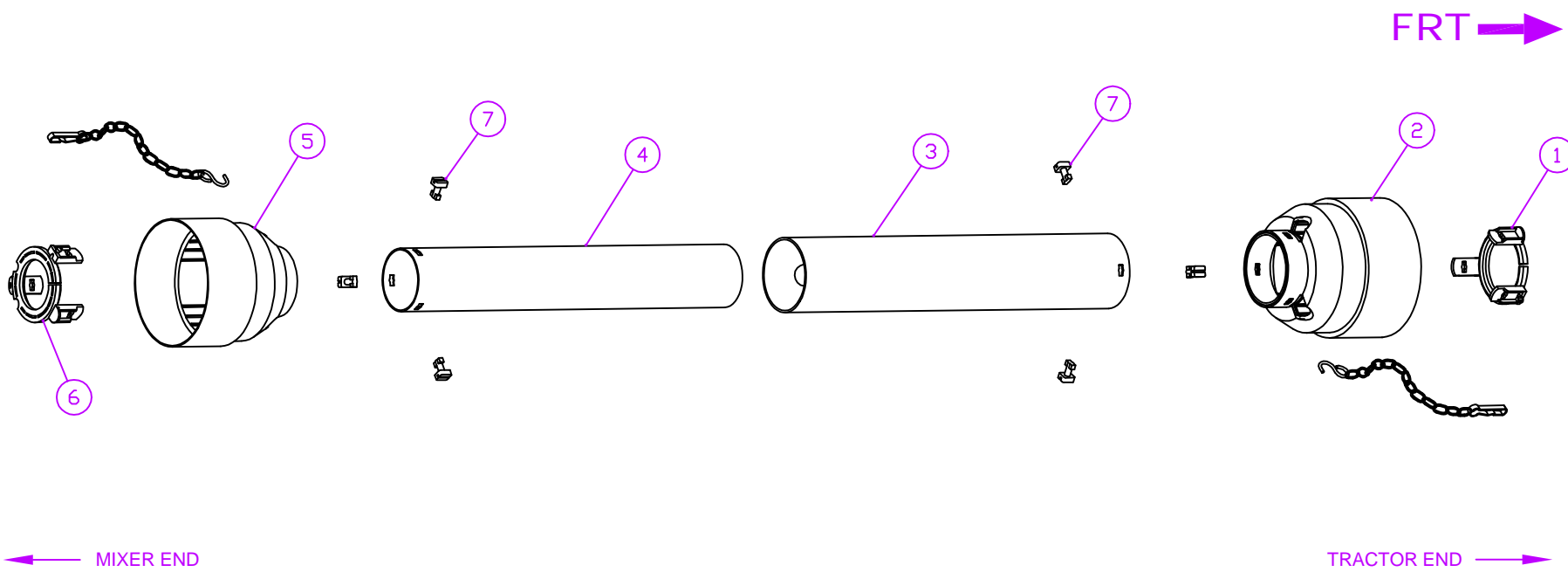

7	GUARD BOLT (PLASTIC)	6	070-00-59
6	RETAINING COLLAR (MIXER END)	1	070-00-40
5	CONE GUARD (MIXER END)	1	070-00-41
4	INNER TUBE SHIELD (MIXER END)	1	070-00-44
3	OUTER TUBE SHIELD (TRACTOR END)	1	070-00-43
2	CONE GUARD (TRACTOR END)	1	070-00-42
1	RETAINING COLLAR (TRACTOR END)	1	070-00-39
NO.	PART DESC.	QTY	PART NO.

PARTS LIST

DRAWN BY: D. RODGERS		DATE: JUL 19/00	
MODEL: ALL APPLICABLE		SHEET: 1 of 1	
PART/ASSEMBLY NO.:		070-09-00	

JAY-LOR
Fabricating Inc

TITLE: COMPLETE GUARD KIT FOR #6 STANDARD PTO SHAFT

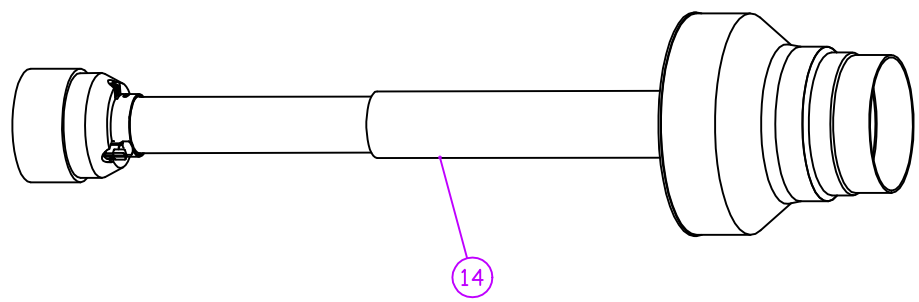
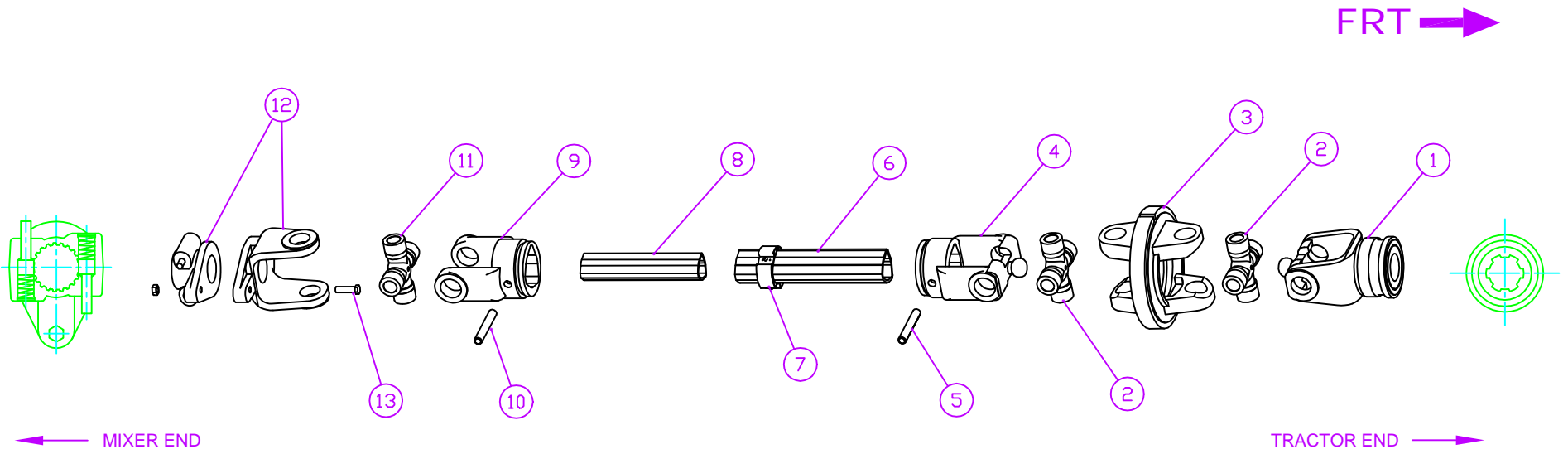

* - SHEAR BOLT YOKE ASSEMBLY

14	#8 CV PTO SHAFT SHIELD ASSEMBLY	1	070-24-50
13	SHEAR BOLT, 12mm X 65mm, GRD 8.8	1	070-04-30
12	MIXER END YOKE (1-3/4", 20-SPLINE)*	1	070-04-29
11	#8 CROSS (35.0mm X 106.5mm)	1	070-04-02
10	ROLL PIN FOR INNER TUBE	1	070-04-28
9	#8 YOKE, INNER TUBE, MIXER END	1	070-04-27
8	#8 PTO INNER TUBE (MIXER END)	1	070-04-26
7	BUSHING FOR OUTER TUBE	1	070-04-25
6	#8 PTO OUTER TUBE (TRACTOR END)	1	070-04-24
5	ROLL PIN FOR OUTER TUBE	1	070-04-04
4	#8 YOKE, OUTER TUBE, TRACTOR END	1	070-04-23
3	#8 CV YOKE, TRACTOR END	1	070-04-22
2	#8 CROSS (35.0mm X 113.8mm)	2	070-04-01
1	TRACTOR END YOKE (1-3/8", 6-SPLINE)	1	070-04-20
NO.	PART DESC.	QTY	PART NO.

PARTS LIST

DRAWN BY:		DATE:	
D. RODGERS		JUL 20/00	
MODEL:		SHEET:	
ALL APPLICABLE		1 of 1	
PART/ASSEMBLY NO:		070-24-01	



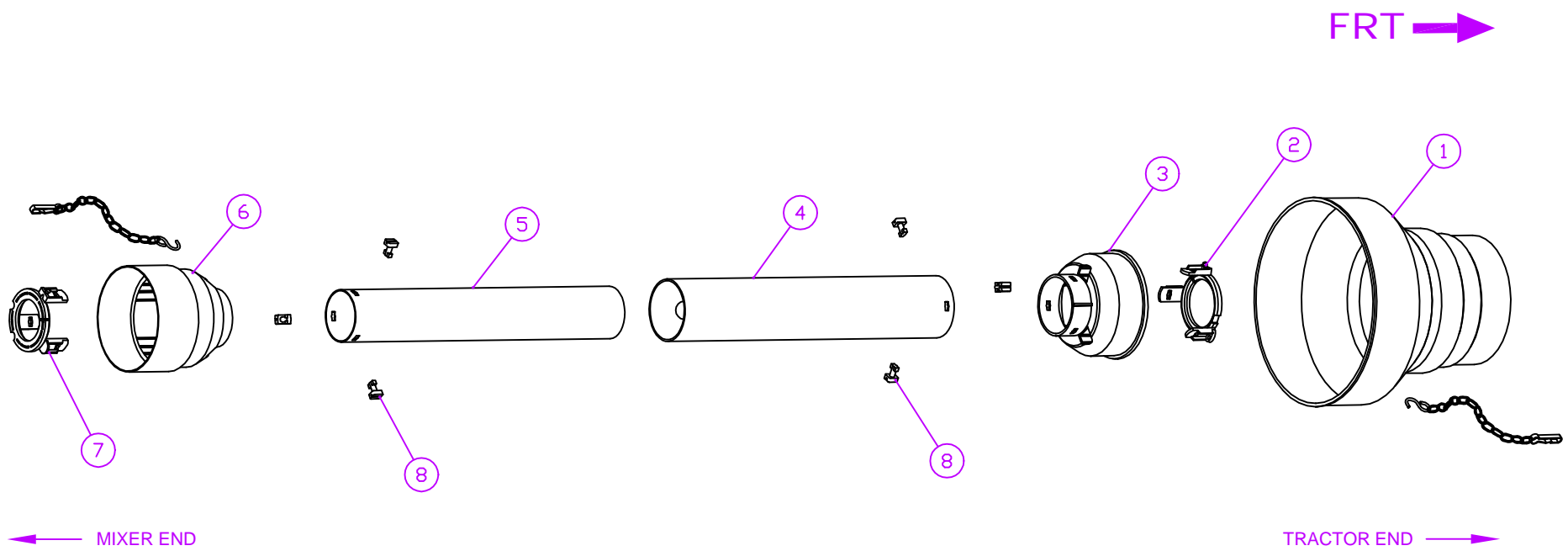

8	GUARD BOLT (PLASTIC)	6	070-00-59
7	RETAINING COLLAR (MIXER END)	1	070-04-57
6	CONE GUARD (MIXER END)	1	070-04-56
5	INNER TUBE SHIELD (MIXER END)	1	070-04-55
4	OUTER TUBE SHIELD (TRACTOR END)	1	070-04-54
3	CONE GUARD (TRACTOR END)	1	070-04-53
2	RETAINING COLLAR (TRACTOR END)	1	070-04-52
1	OUTER CONE GUARD (TRACTOR END)	1	070-04-51
NO.	PART DESC.	QTY	PART NO.

PARTS LIST

DRAWN BY: D. RODGERS		DATE: JUL 20/00	
MODEL: ALL APPLICABLE		SHEET: 1 of 1	
PART/ASSEMBLY NO.:		070-24-50	

JAY-LOR
Fabricating Inc

TITLE: COMPLETE GUARD KIT FOR #8 CV PTO SHAFT

JAY•LOR®

Cutter • Mixer • Feeder

08 – LUBE SYSTEM

“Putting the ‘Total’ into TMR”

JAY-LOR® Fabricating Inc.
RR # 2 Orton, Ontario, Canada, L0N 1N0 Tel: (519) 787-9353 Fax: (519) 787-7053

* - MOUNTING BRACKET NOT INCLUDED W/ ASSEMBLY.

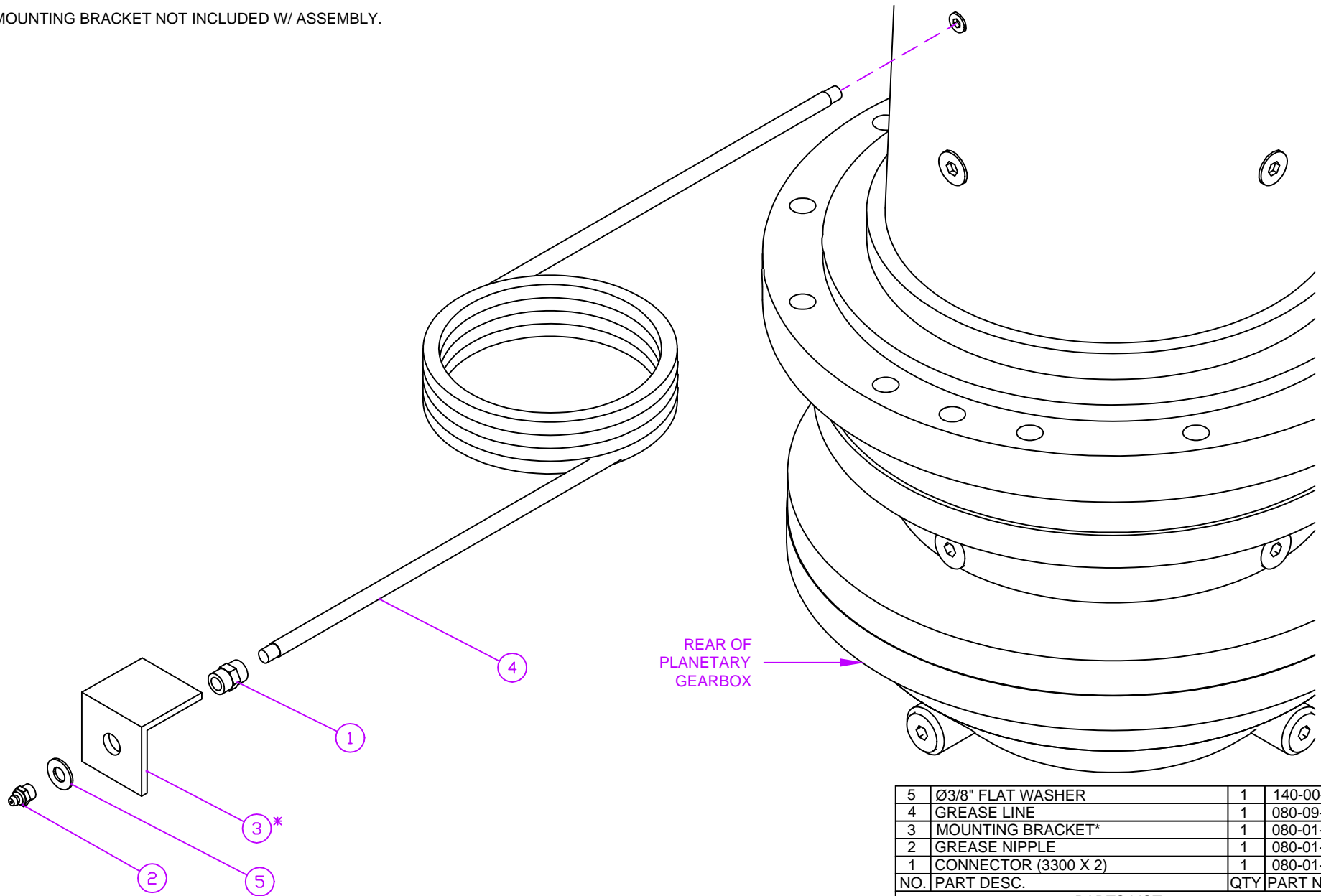

NO.	PART DESC.	QTY	PART NO.
5	Ø3/8" FLAT WASHER	1	140-00-66
4	GREASE LINE	1	080-09-01
3	MOUNTING BRACKET*	1	080-01-08
2	GREASE NIPPLE	1	080-01-06
1	CONNECTOR (3300 X 2)	1	080-01-05
NO.	PART DESC.	QTY	PART NO.

PARTS LIST

DRAWN BY: D. RODGERS		DATE: MAY 23/00	
MODEL: ALL APPLICABLE		SHEET: 1 of 1	
PART/ASSEMBLY NO: 080-01-00			

JAY-LOR
Fabricating Inc

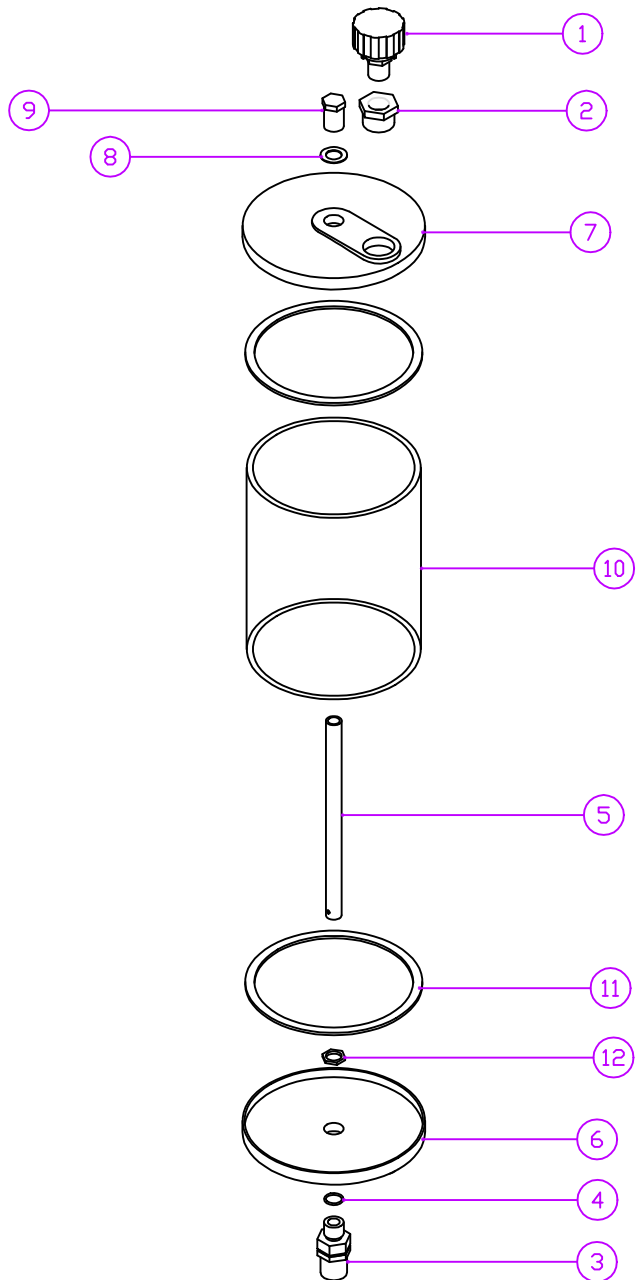

NO.	PART DESC.	QTY	PART NO.
12	RESERVOIR NUT	1	080-04-13
11	RUBBER GASKET	1	080-04-12
10	ACRYLIC RESERVOIR BODY	1	080-04-11
9	RESERVOIR CLOSURE	1	080-04-10
8	WASHER	1	080-04-09
7	RESERVOIR TOP PLATE	1	080-04-08
6	RESERVOIR BOTTOM PLATE	1	080-04-07
5	CONNECTING PIPE	1	080-04-06
4	O-RING FOR ALUMINUM SHANK	1	080-04-05
3	ALUMINUM SHANK	1	080-04-04
2	PLASTIC BUSHING	1	080-04-03
1	BREATHER CAP	1	080-04-02
NO.	PART DESC.	QTY	PART NO.

PARTS LIST

DRAWN BY: D. RODGERS DATE: MAY 19/00

MODEL: ALL APPLICABLE SHEET: 1 of 1

PART/ASSEMBLY NO: 080-04-00



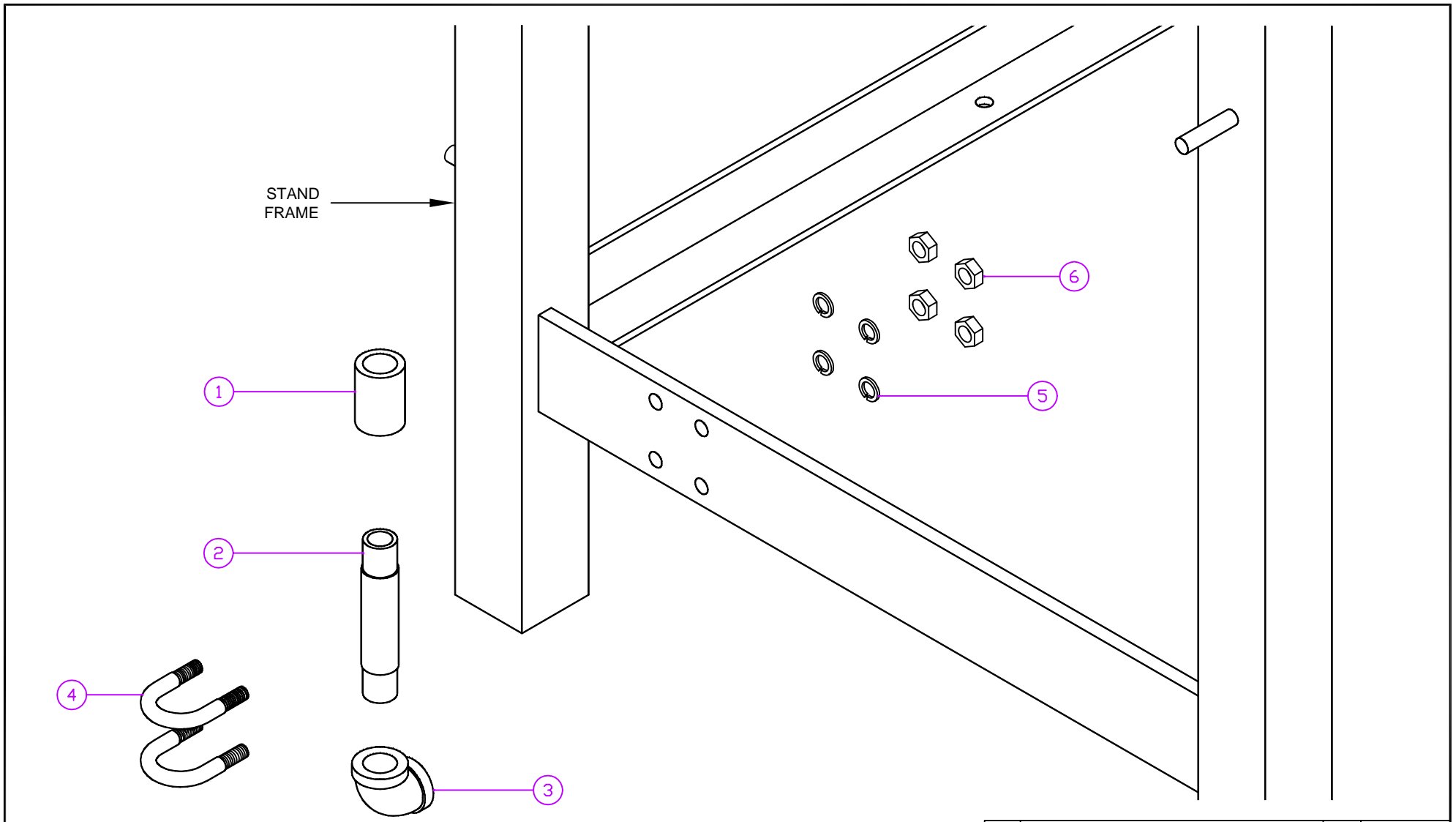

6	Ø3/8" NUT	4	140-00-85
5	Ø3/8" LOCK WASHER	4	140-00-71
4	PIPE CLAMP	2	080-07-06
3	Ø1/2" NPT ELBOW	1	080-07-03
2	Ø1/2" NIPPLE	1	080-07-02
1	Ø1/2" COUPLING	1	080-07-01
NO.	PART DESC.	QTY	PART NO.

PARTS LIST

DRAWN BY: D. RODGERS	DATE: MAY 23/00
MODEL: ALL APPLICABLE	SHEET: 1 of 1
PART/ASSEMBLY NO: 080-07-00	

JAY•LOR
Fabricating Inc

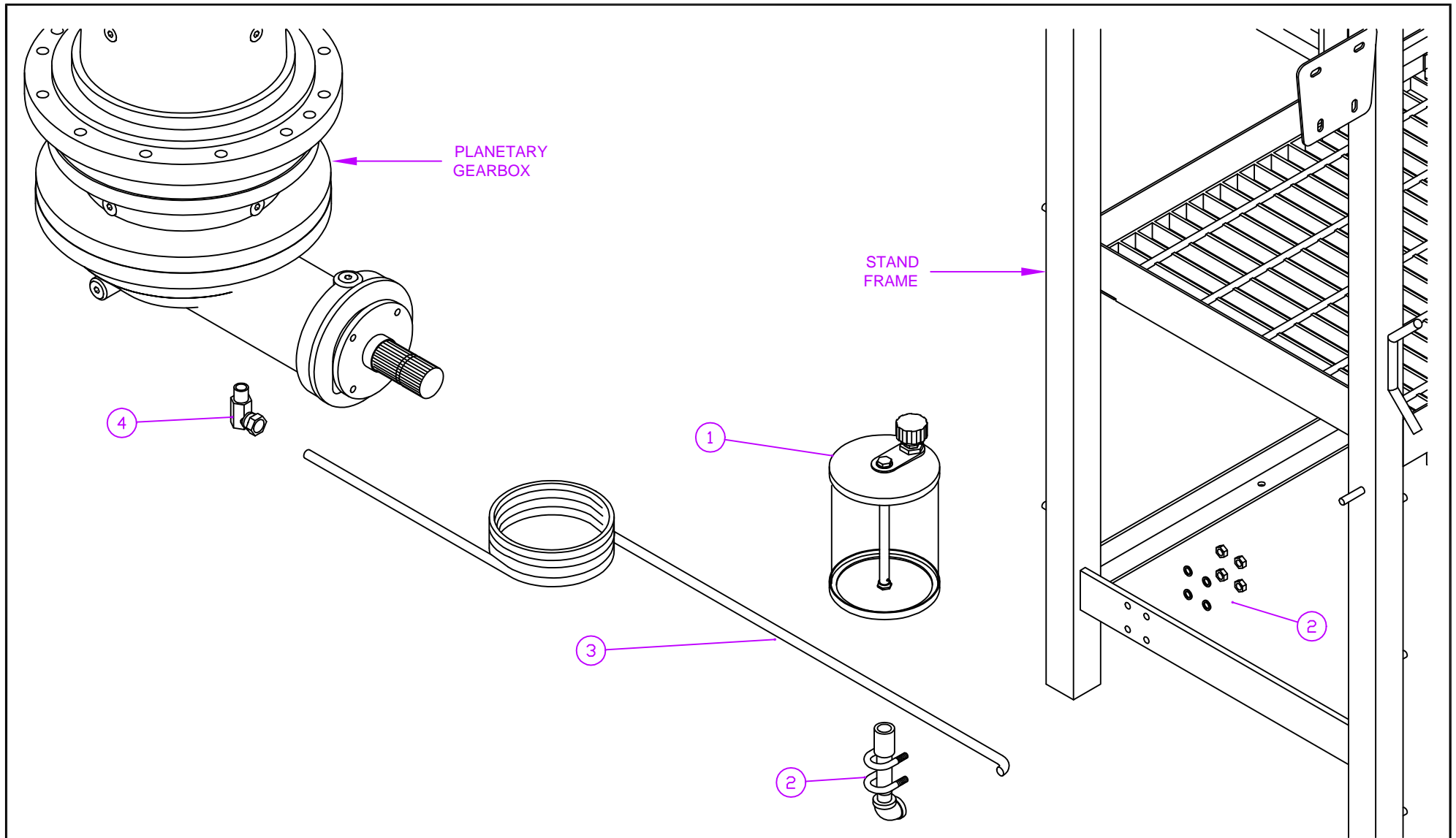

PLANETARY
GEARBOX

STAND
FRAME

4	HYDRAULIC ELBOW	1	080-07-05
3	HOSE	1	080-07-04
2	RESERVOIR MOUNTING ASSEMBLY	1	080-07-00
1	ACRYLIC RESERVOIR ASSEMBLY	1	080-04-00
NO.	PART DESC.	QTY	PART NO.

PARTS LIST

DRAWN BY: D. RODGERS		DATE: MAY 19/00	
MODEL: ALL APPLICABLE		SHEET: 1 of 1	
PART/ASSEMBLY NO: 080-13-00			



TITLE: COMPLETE EXTERNAL OIL RESERVOIR ASSEMBLY: INCLUDES RESERVOIR, HOSE KIT, FITTINGS, AND HARDWARE

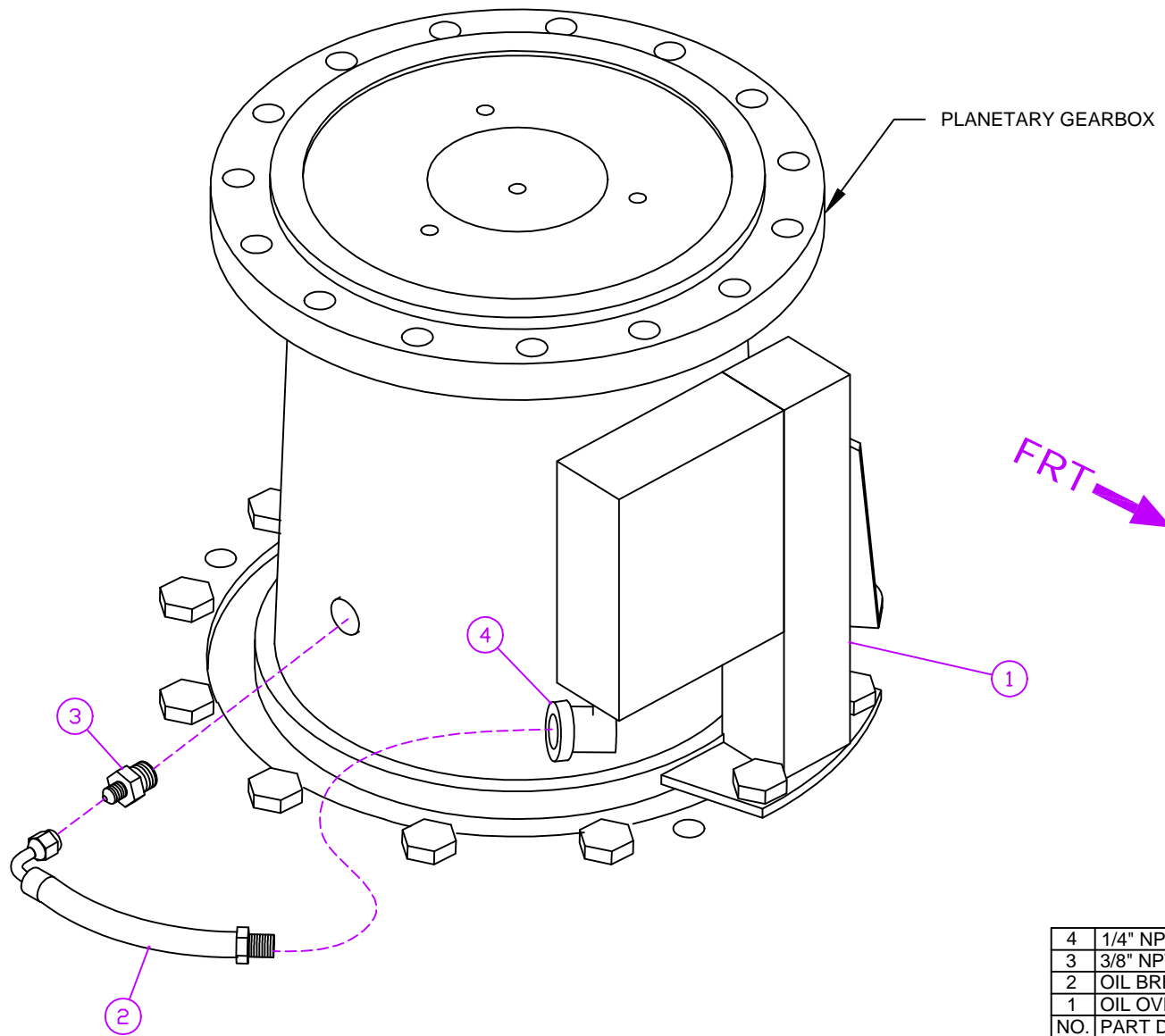

PARTS LIST			
NO.	PART DESC.	QTY	PART NO.
4	1/4" NPT STREET ELBOW 90°	1	080-00-51
3	3/8" NPT TO 1/4" JIC NIPPLE	1	080-00-52
2	OIL BREATHER LINE ASSEMBLY	1	080-00-53
1	OIL OVERFLOW RESERVOIR	1	080-21-02
NO.	PART DESC.	QTY	PART NO.

PARTS LIST			
DRAWN BY: D. RODGERS		DATE: JUL 11/00	
MODEL: ALL APPLICABLE		SHEET: 1 of 1	
PART/ASSEMBLY NO: 080-21-01			

TITLE: COMPLETE INTERNAL OIL OVERFLOW RESERVOIR ASSEMBLY: INCLUDES RESERVOIR, HOSE KIT, AND FITTINGS.

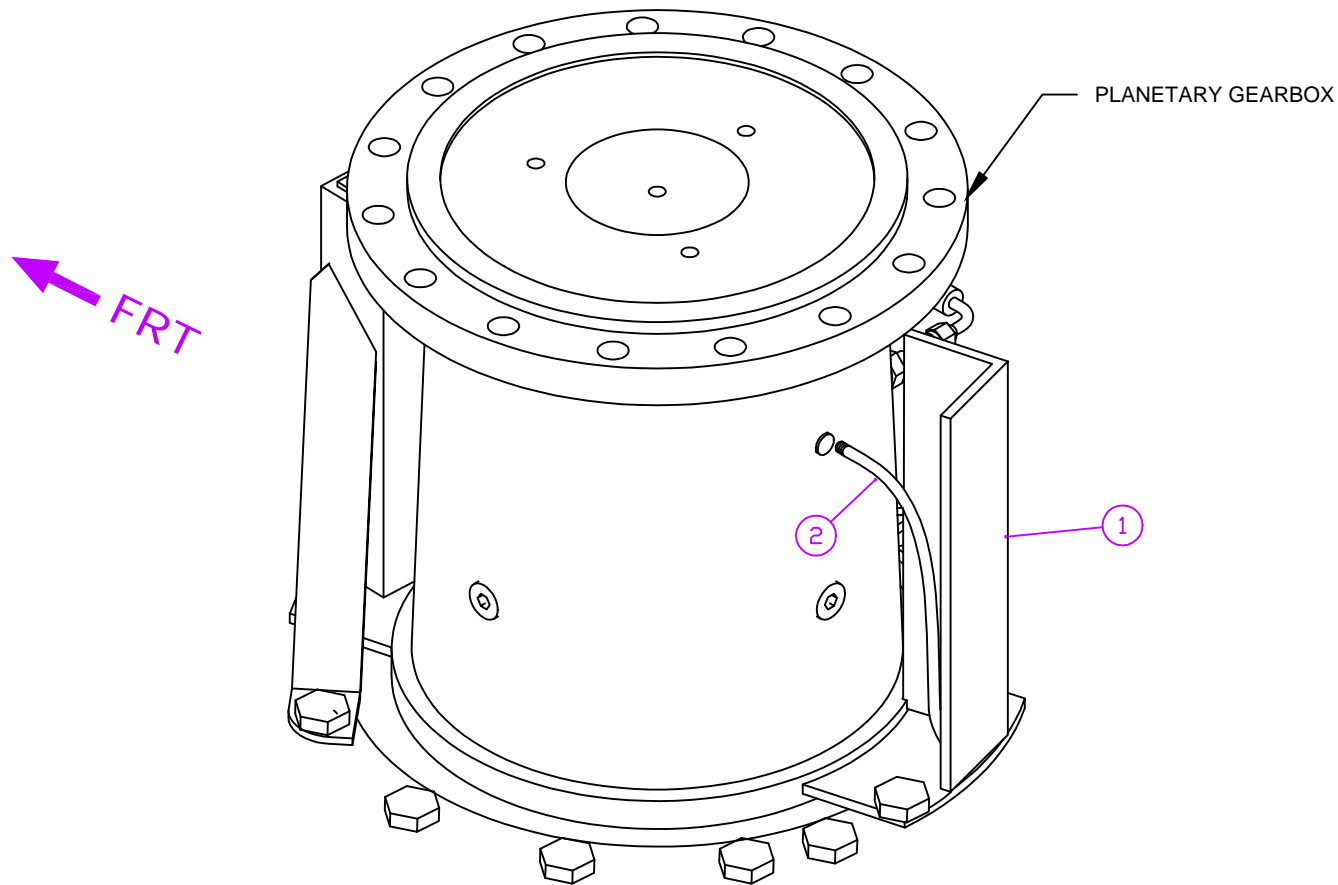

2	GREASE LINE	1	080-09-01
1	GREASE LINE PROTECTOR ASSEMBLY	1	080-41-02
NO.	PART DESC.	QTY	PART NO.

PARTS LIST

DRAWN BY: D. RODGERS		DATE: JUL 11/00	
MODEL: ALL APPLICABLE		SHEET: 1 of 1	
PART/ASSEMBLY NO: 080-41-02			

TITLE: INTERNAL GREASE LINE PROTECTOR ASSEMBLY

JAY•LOR[®]

Cutter • Mixer • Feeder

09 – HYDRAULICS

“Putting the ‘Total’ into TMR”

JAY-LOR[®] Fabricating Inc.
RR # 2 Orton, Ontario, Canada, L0N 1N0 Tel: (519) 787-9353 Fax: (519) 787-7053

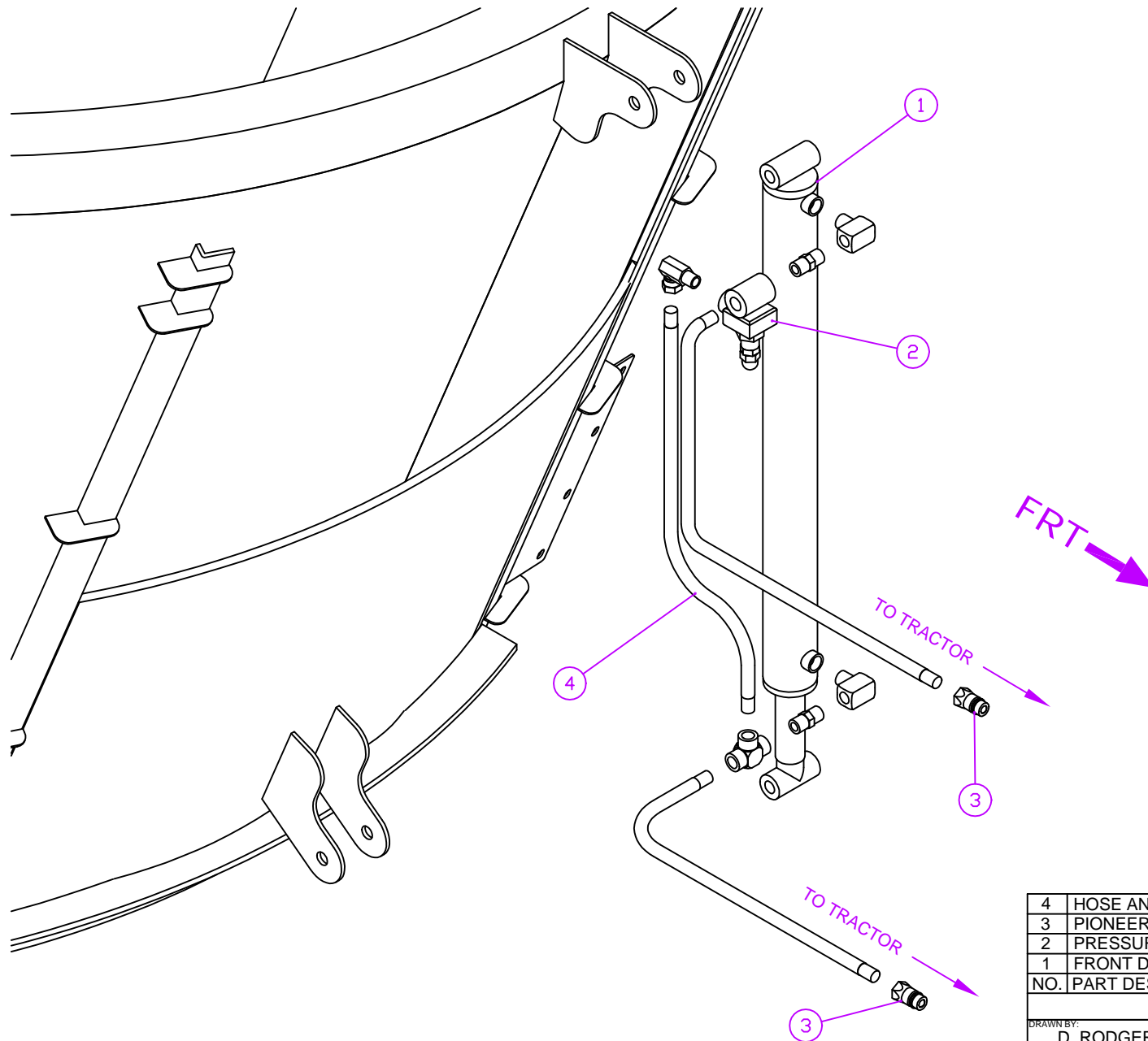

NO.	PART DESC.	QTY	PART NO.
4	HOSE AND FITTING ASSEMBLY	1	090-20-03
3	PIONEER ENDS	2	090-00-19
2	PRESSURE RELIEF VALVE	1	090-00-21
1	FRONT DOOR CYLINDER (66")	1	090-03-00
NO.	PART DESC.	QTY	PART NO.

PARTS LIST

DRAWN BY: D. RODGERS		DATE: JUL 14/00	
MODEL: ALL APPLICABLE		SHEET: 1 of 1	
PART/ASSEMBLY NO: 090-20-00			



TITLE: FRONT DISCHARGE DOOR HYDRAULIC ASSEMBLY W/ CYLINDER

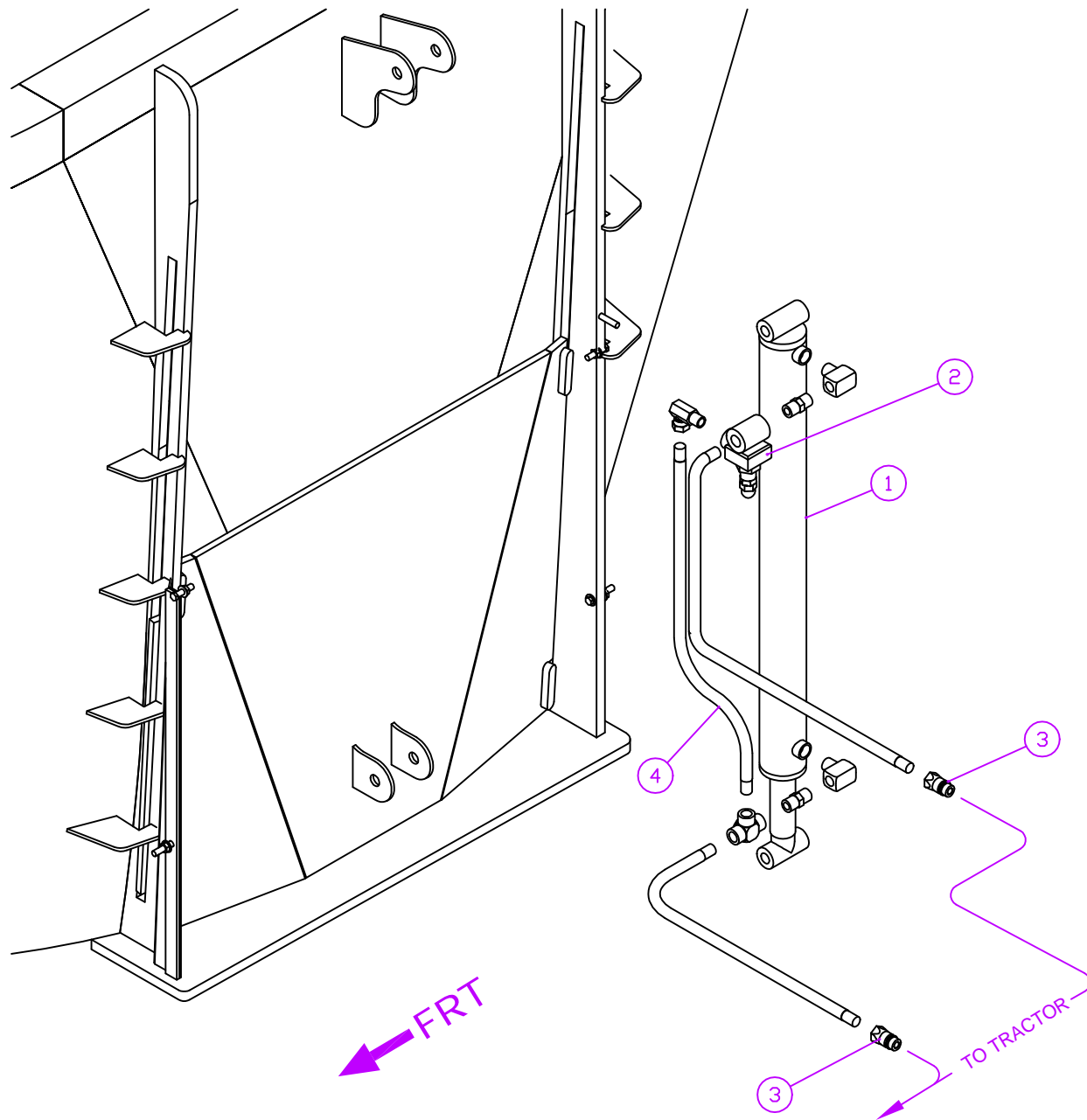

NO.	PART DESC.	QTY	PART NO.
4	HOSE AND FITTING ASSEMBLY	1	090-22-03
3	PIONEER ENDS	2	090-00-19
2	PRESSURE RELIEF VALVE	1	090-00-21
1	C-SIDE DOOR CYLINDER (56")	1	090-02-00

PARTS LIST

DRAWN BY: D. RODGERS		DATE: JUL 17/00	
MODEL: ALL APPLICABLE		SHEET: 1 of 1	
PART/ASSEMBLY NO: 090-22-00			

JAY-LOR
Fabricating Inc

TITLE: CENTER-SIDE DISCHARGE DOOR HYDRAULIC ASSEMBLY W/ CYLINDER

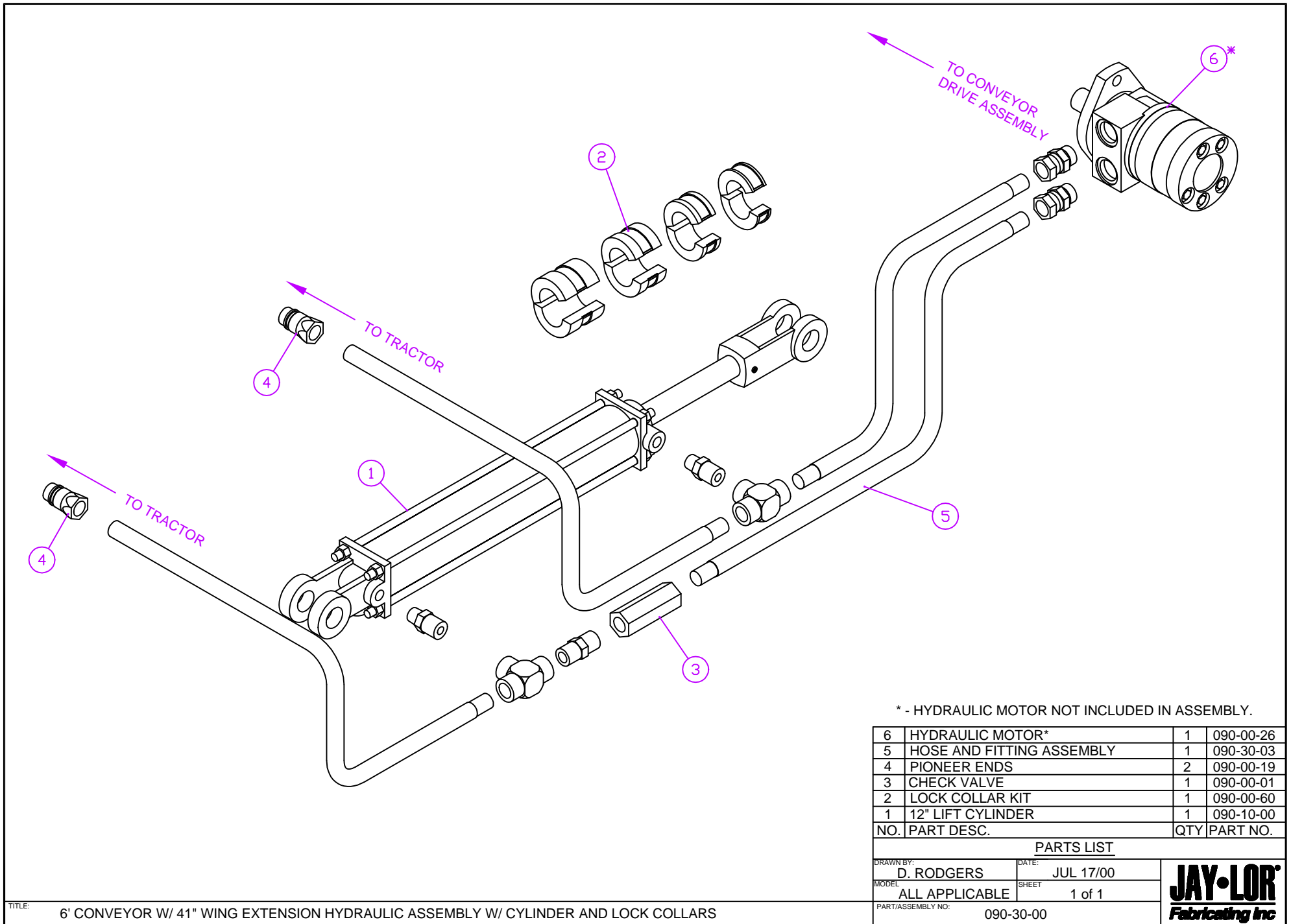

* - HYDRAULIC MOTOR NOT INCLUDED IN ASSEMBLY.

NO.	PART DESC.	QTY	PART NO.
6	HYDRAULIC MOTOR*	1	090-00-26
5	HOSE AND FITTING ASSEMBLY	1	090-30-03
4	PIONEER ENDS	2	090-00-19
3	CHECK VALVE	1	090-00-01
2	LOCK COLLAR KIT	1	090-00-60
1	12" LIFT CYLINDER	1	090-10-00
NO.	PART DESC.	QTY	PART NO.

PARTS LIST

DRAWN BY: D. RODGERS		DATE: JUL 17/00	
MODEL: ALL APPLICABLE		SHEET: 1 of 1	
PART/ASSEMBLY NO: 090-30-00			



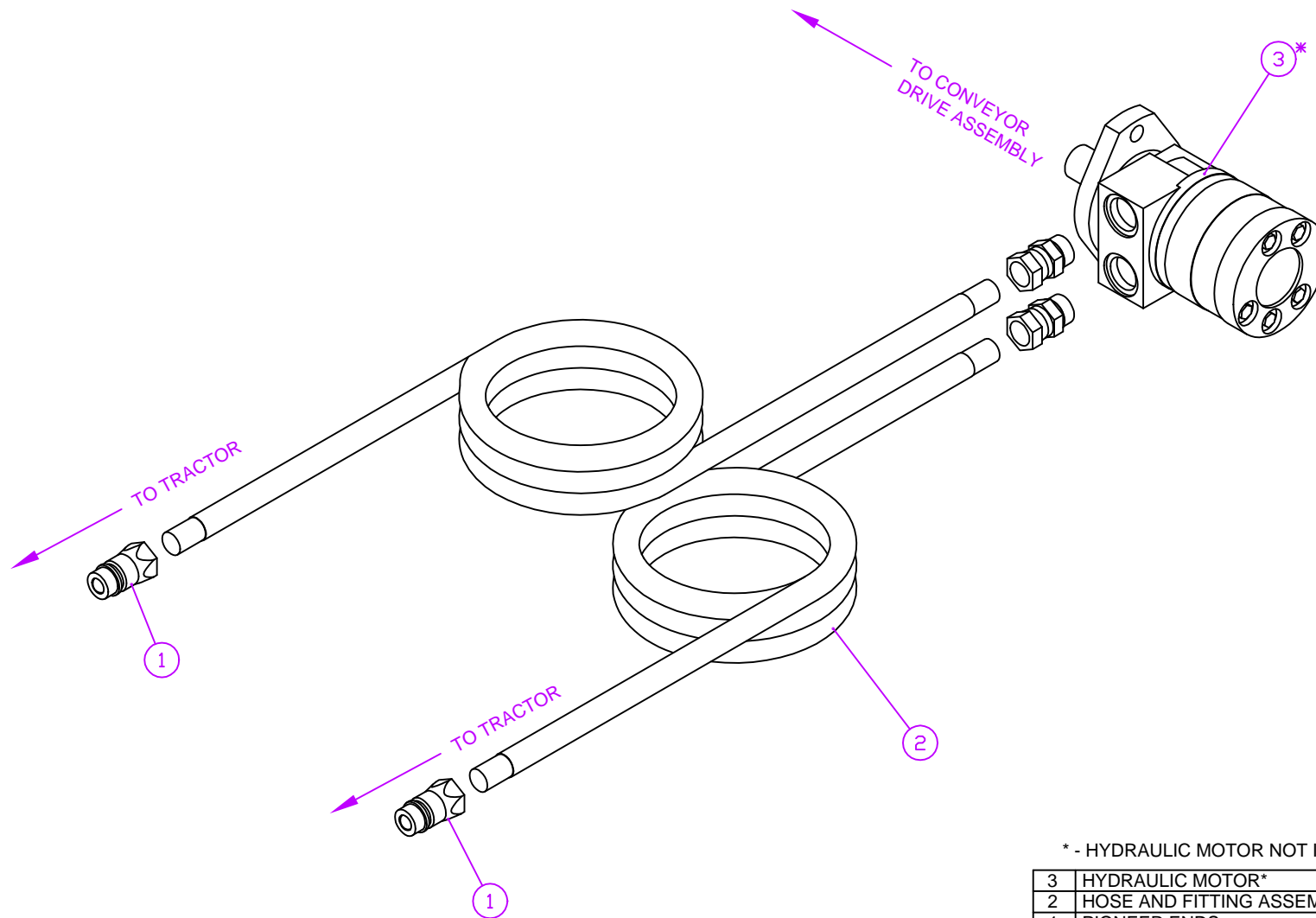

* - HYDRAULIC MOTOR NOT INCLUDED IN ASSEMBLY

3	HYDRAULIC MOTOR*	1	090-00-26
2	HOSE AND FITTING ASSEMBLY	1	090-32-03
1	PIONEER ENDS	2	090-00-19
NO.	PART DESC.	QTY	PART NO.

PARTS LIST

DRAWN BY: D. RODGERS		DATE: JUL 17/00	
MODEL: ALL APPLICABLE		SHEET: 1 of 1	
PART/ASSEMBLY NO:		090-32-00	



JAY•LOR[®]

Cutter • Mixer • Feeder

10 – SCALES

“Putting the ‘Total’ into TMR”

JAY-LOR[®] Fabricating Inc.
RR # 2 Orton, Ontario, Canada, L0N 1N0 Tel: (519) 787-9353 Fax: (519) 787-7053

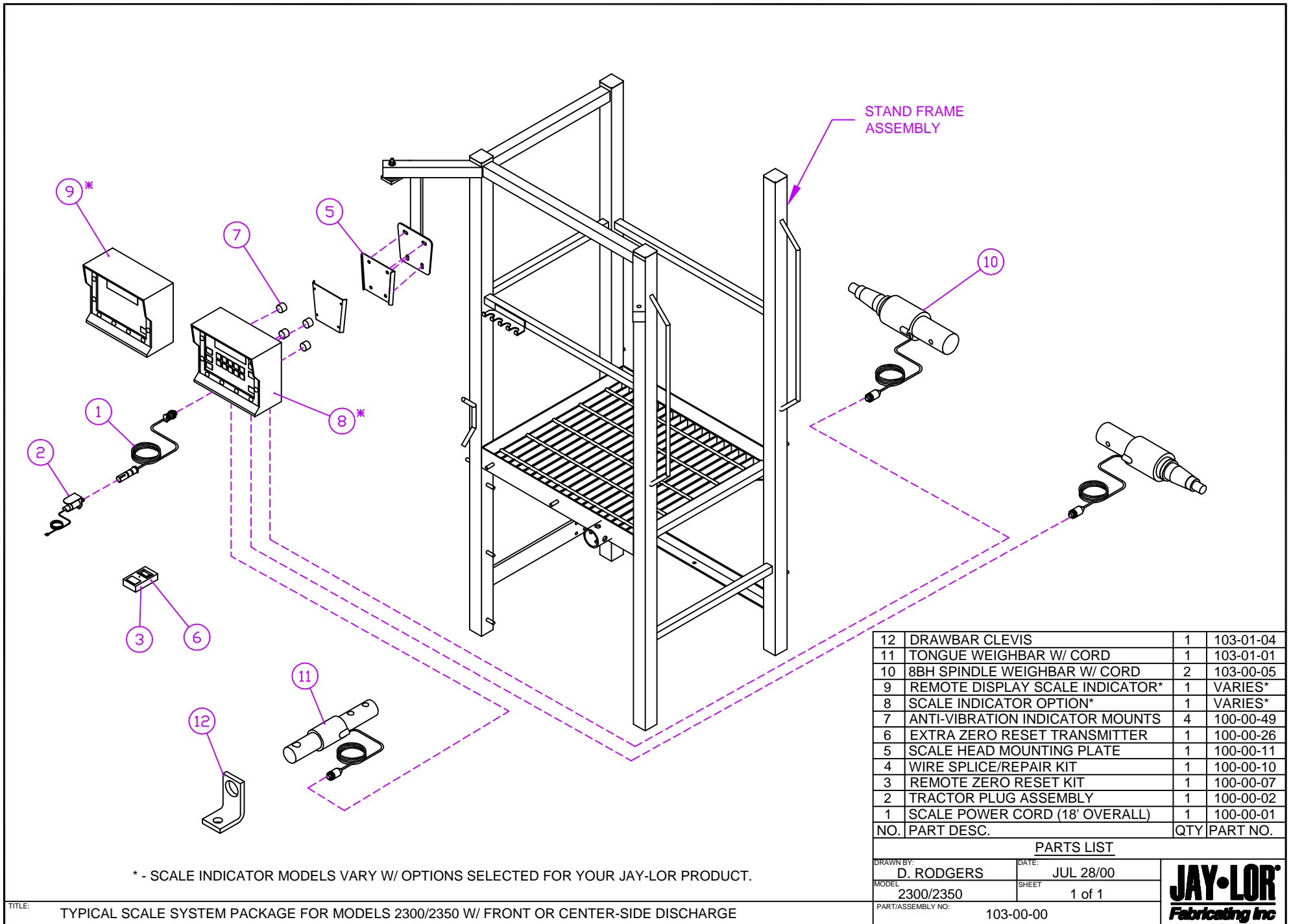

STAND FRAME ASSEMBLY

12	DRAWBAR CLEVIS	1	103-01-04
11	TONGUE WEIGHBAR W/ CORD	1	103-01-01
10	8BH SPINDLE WEIGHBAR W/ CORD	2	103-00-05
9	REMOTE DISPLAY SCALE INDICATOR*	1	VARIES*
8	SCALE INDICATOR OPTION*	1	VARIES*
7	ANTI-VIBRATION INDICATOR MOUNTS	4	100-00-49
6	EXTRA ZERO RESET TRANSMITTER	1	100-00-26
5	SCALE HEAD MOUNTING PLATE	1	100-00-11
4	WIRE SPLICE/REPAIR KIT	1	100-00-10
3	REMOTE ZERO RESET KIT	1	100-00-07
2	TRACTOR PLUG ASSEMBLY	1	100-00-02
1	SCALE POWER CORD (18' OVERALL)	1	100-00-01
NO.	PART DESC.	QTY	PART NO.

PARTS LIST

DRAWN BY:	D. RODGERS	DATE:	JUL 28/00
MODEL:	2300/2350	SHEET:	1 of 1
PART/ASSEMBLY NO.:	103-00-00		



* - SCALE INDICATOR MODELS VARY W/ OPTIONS SELECTED FOR YOUR JAY-LOR PRODUCT.

JAY•LOR[®]

Cutter • Mixer • Feeder

11 – SHIELDS

“Putting the ‘Total’ into TMR”

JAY-LOR[®] Fabricating Inc.
RR # 2 Orton, Ontario, Canada, L0N 1N0 Tel: (519) 787-9353 Fax: (519) 787-7053

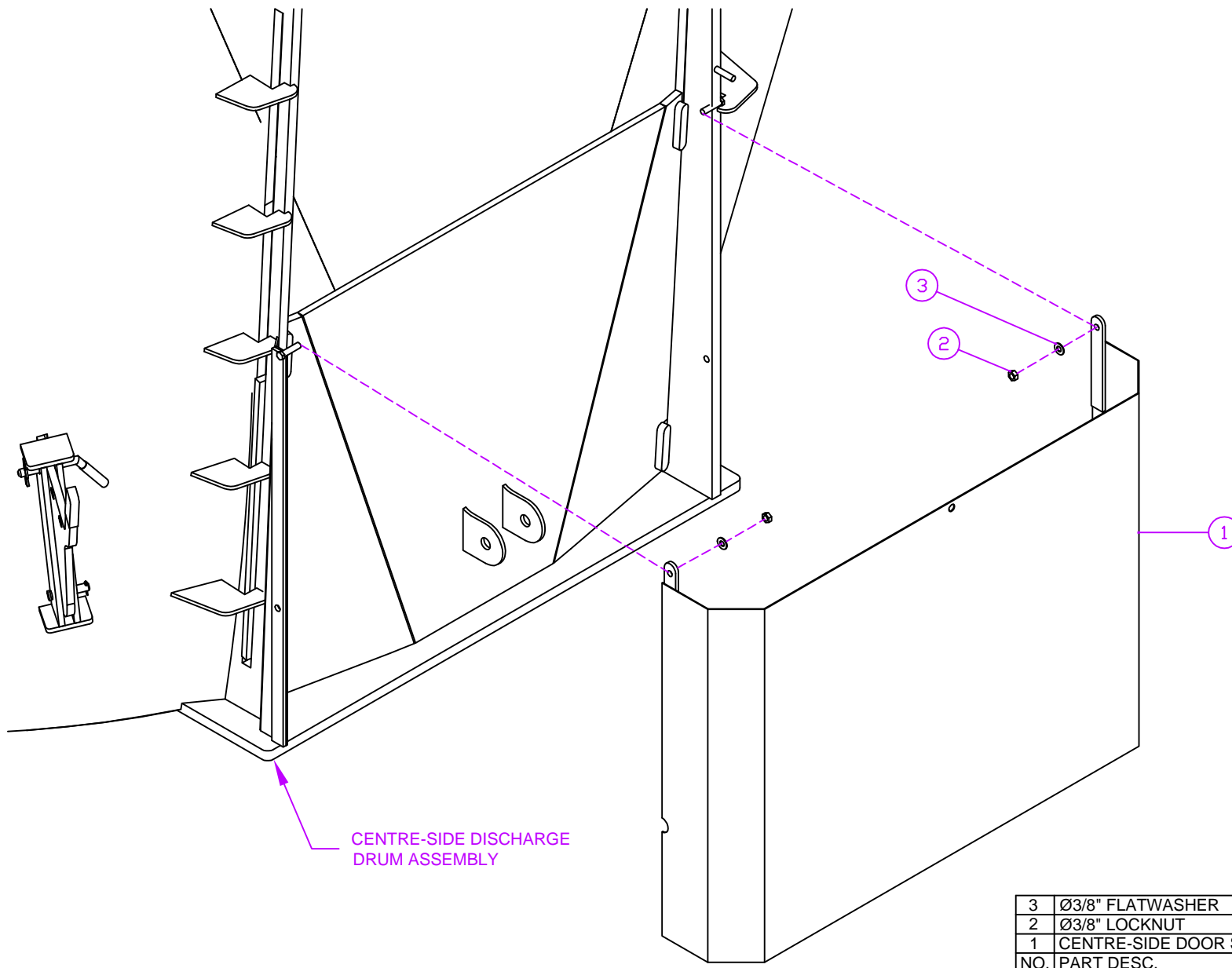

CENTRE-SIDE DISCHARGE
DRUM ASSEMBLY

3	Ø3/8" FLATWASHER	2	140-00-66
2	Ø3/8" LOCKNUT	2	140-00-78
1	CENTRE-SIDE DOOR SHIELD	1	110-01-01
NO.	PART DESC.	QTY	PART NO.

PARTS LIST

DRAWN BY: D. RODGERS	DATE: MAY 29/00
MODEL: ALL APPLICABLE	SHEET: 1 of 1
PART/ASSEMBLY NO: 110-01-00	



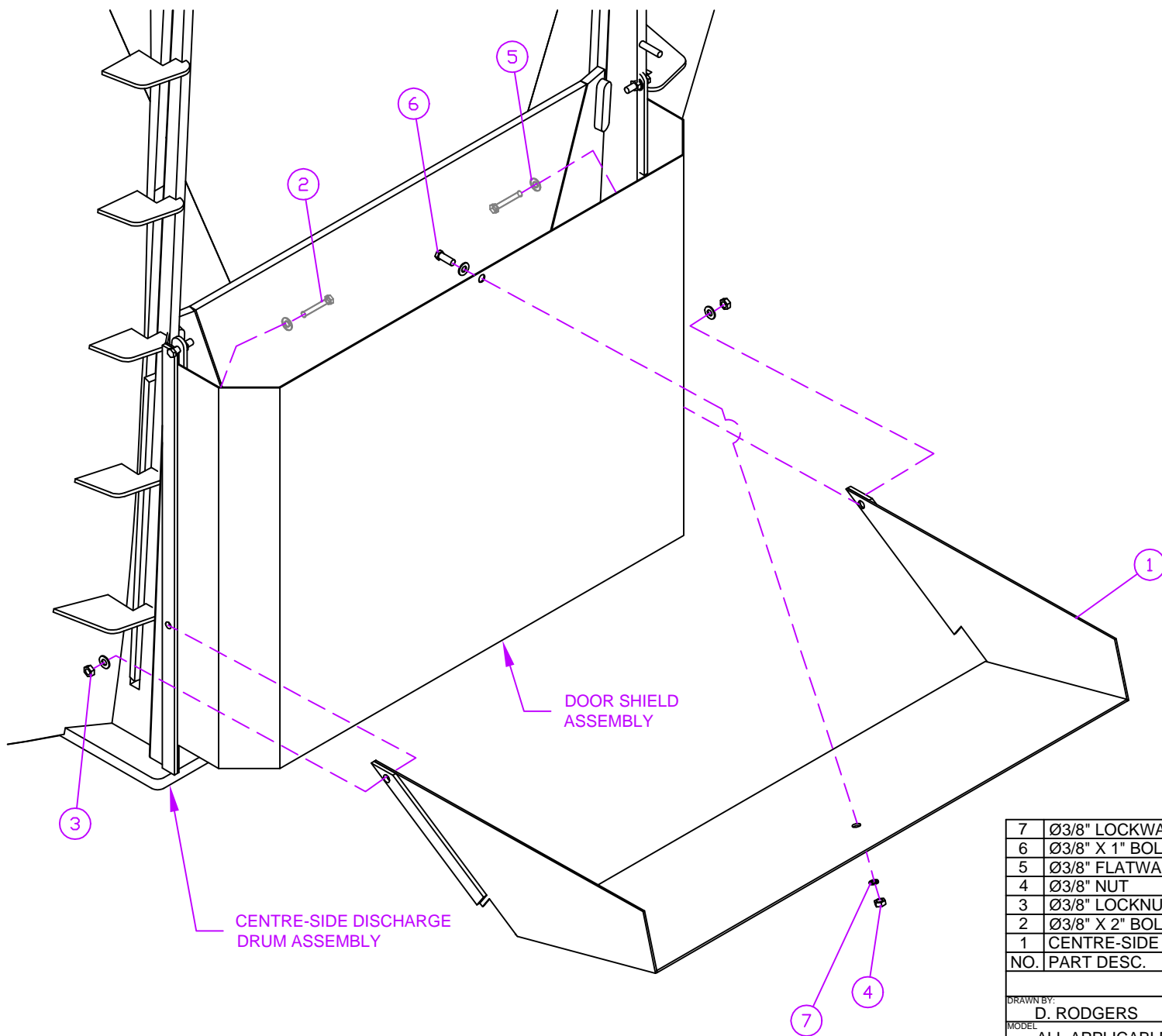

CENTRE-SIDE DISCHARGE DRUM ASSEMBLY

DOOR SHIELD ASSEMBLY

7	Ø3/8" LOCKWASHER	1	140-00-71
6	Ø3/8" X 1" BOLT	1	140-00-12
5	Ø3/8" FLATWASHER	5	140-00-66
4	Ø3/8" NUT	1	140-00-85
3	Ø3/8" LOCKNUT	2	140-00-78
2	Ø3/8" X 2" BOLT	2	140-00-13
1	CENTRE-SIDE DISCHARGE CHUTE	1	110-02-01
NO.	PART DESC.	QTY	PART NO.

PARTS LIST

DRAWN BY: D. RODGERS	DATE: MAY 29/00
MODEL: ALL APPLICABLE	SHEET: 1 of 1
PART/ASSEMBLY NO: 110-02-00	

JAY•LOR
Fabricating Inc

TITLE: STANDARD DISCHARGE CHUTE FOR MODELS EQUIPPED W/ CENTRE-SIDE DISCHARGE

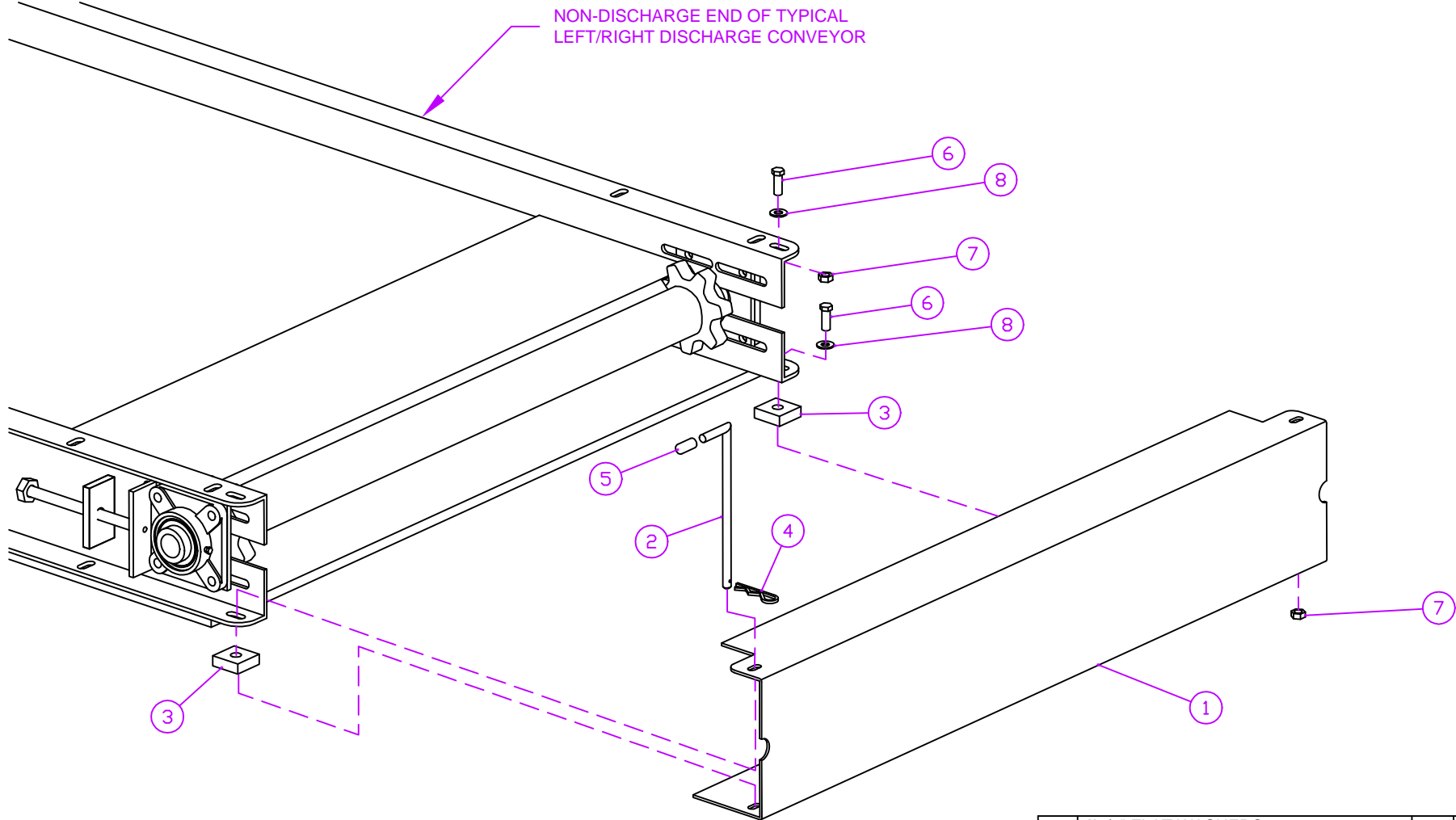

8	Ø3/8" FLAT WASHERS	2	140-00-66
7	Ø3/8" HINGE LOCKNUTS	2	140-00-78
6	Ø3/8" X 1" HINGE BOLTS	2	140-00-12
5	CONVEYOR BOOT PIN CAP	1	150-00-01
4	HAIR PIN	1	010-01-07
3	PLASTIC SPACER BLOCK	2	110-00-35
2	CONVEYOR BOOT PIN	1	110-04-03
1	CONVEYOR BOOT SHIELD	1	110-04-01
NO.	PART DESC.	QTY	PART NO.

PARTS LIST

DRAWN BY:	D. RODGERS	DATE:	MAY 31/00
MODEL:	ALL APPLICABLE	SHEET:	1 of 1
PART/ASSEMBLY NO.:	110-04-00		

JAY-LOR
Fabricating Inc

6' CONVEYOR W/ 41" WING EXTENSION
(ASSEMBLY #060-08-01)

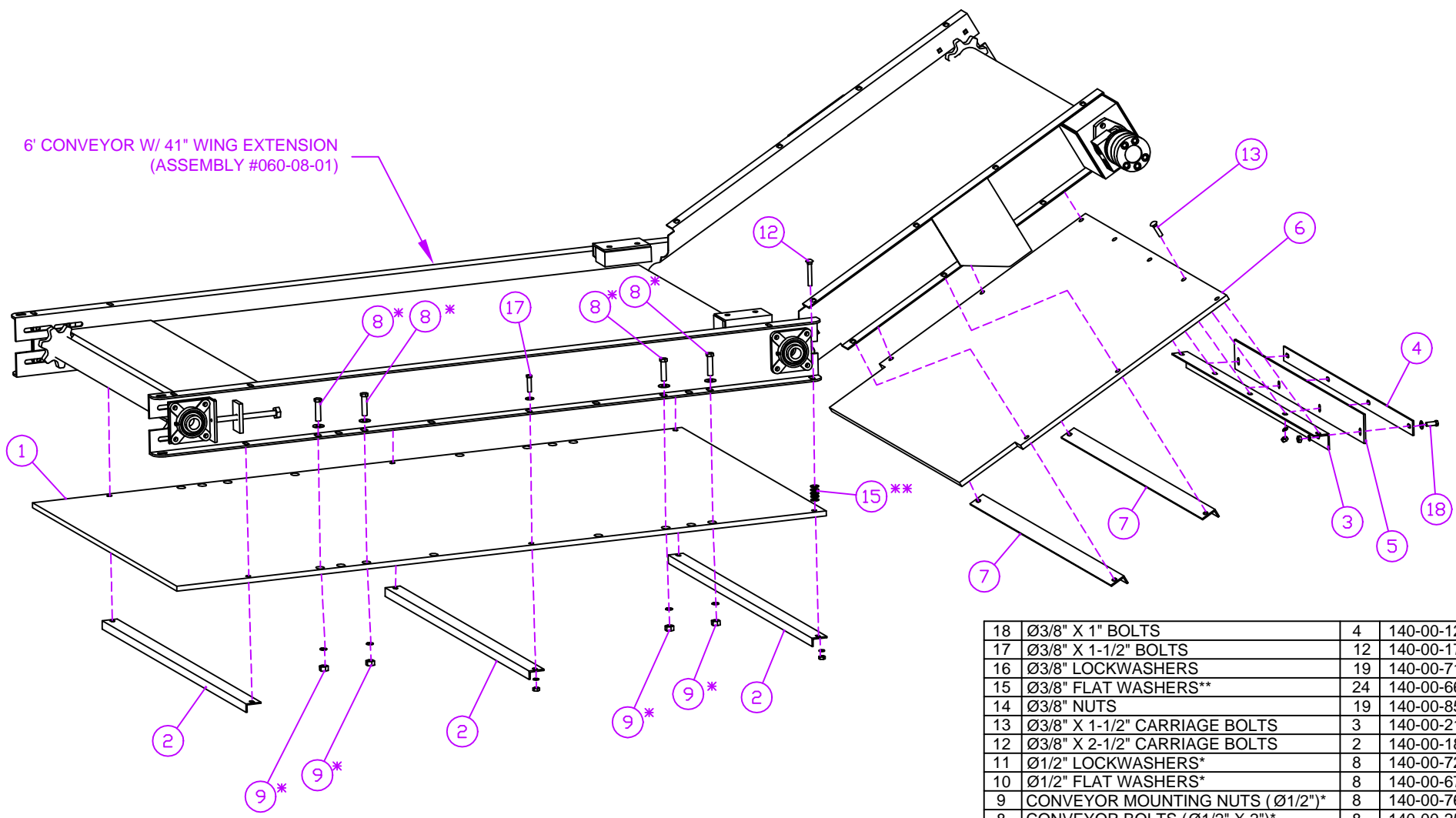

* - USED FOR MOUNTING CONVEYOR ASSEMBLY TO TYPICAL JAY-LOR FRAME UNIT.
 ** - STACK 5 FLAT WASHERS EACH SIDE AS SPACER FOR WING EXTENSION MOVEMENT.

18	Ø3/8" X 1" BOLTS	4	140-00-12
17	Ø3/8" X 1-1/2" BOLTS	12	140-00-17
16	Ø3/8" LOCKWASHERS	19	140-00-71
15	Ø3/8" FLAT WASHERS**	24	140-00-66
14	Ø3/8" NUTS	19	140-00-85
13	Ø3/8" X 1-1/2" CARRIAGE BOLTS	3	140-00-21
12	Ø3/8" X 2-1/2" CARRIAGE BOLTS	2	140-00-18
11	Ø1/2" LOCKWASHERS*	8	140-00-72
10	Ø1/2" FLAT WASHERS*	8	140-00-67
9	CONVEYOR MOUNTING NUTS (Ø1/2")*	8	140-00-76
8	CONVEYOR BOLTS (Ø1/2" X 2")*	8	140-00-25
7	SUPPORT ANGLE	2	110-00-36
6	41" EXTENSION PLASTIC SHIELD	1	110-00-34
5	RUBBER FLAP	1	110-00-08
4	RUBBER FLAP RETAINER	1	110-00-07
3	RUBBER/PLASTIC SUPPORT ANGLE	1	110-00-05
2	SUPPORT ANGLE	3	110-00-03
1	6' CONVEYOR PLASTIC SHIELD	1	110-00-02
NO.	PART DESC.	QTY	PART NO.

PARTS LIST

DRAWN BY: D. RODGERS	DATE: MAY 31/00
MODEL: ALL APPLICABLE	SHEET: 1 of 1
PART/ASSEMBLY NO: 110-10-01	



* - USE PART #110-00-27 FOR LEFT DISCHARGE DIRECTION UNITS. USE PART #110-00-28 FOR RIGHT DISCHARGE DIRECTION UNITS.
 ** - PART #110-00-62 APPLIES TO ALL MODELS EXCEPT MODEL 2350. USE PART #113-00-01 FOR MODEL 2350.

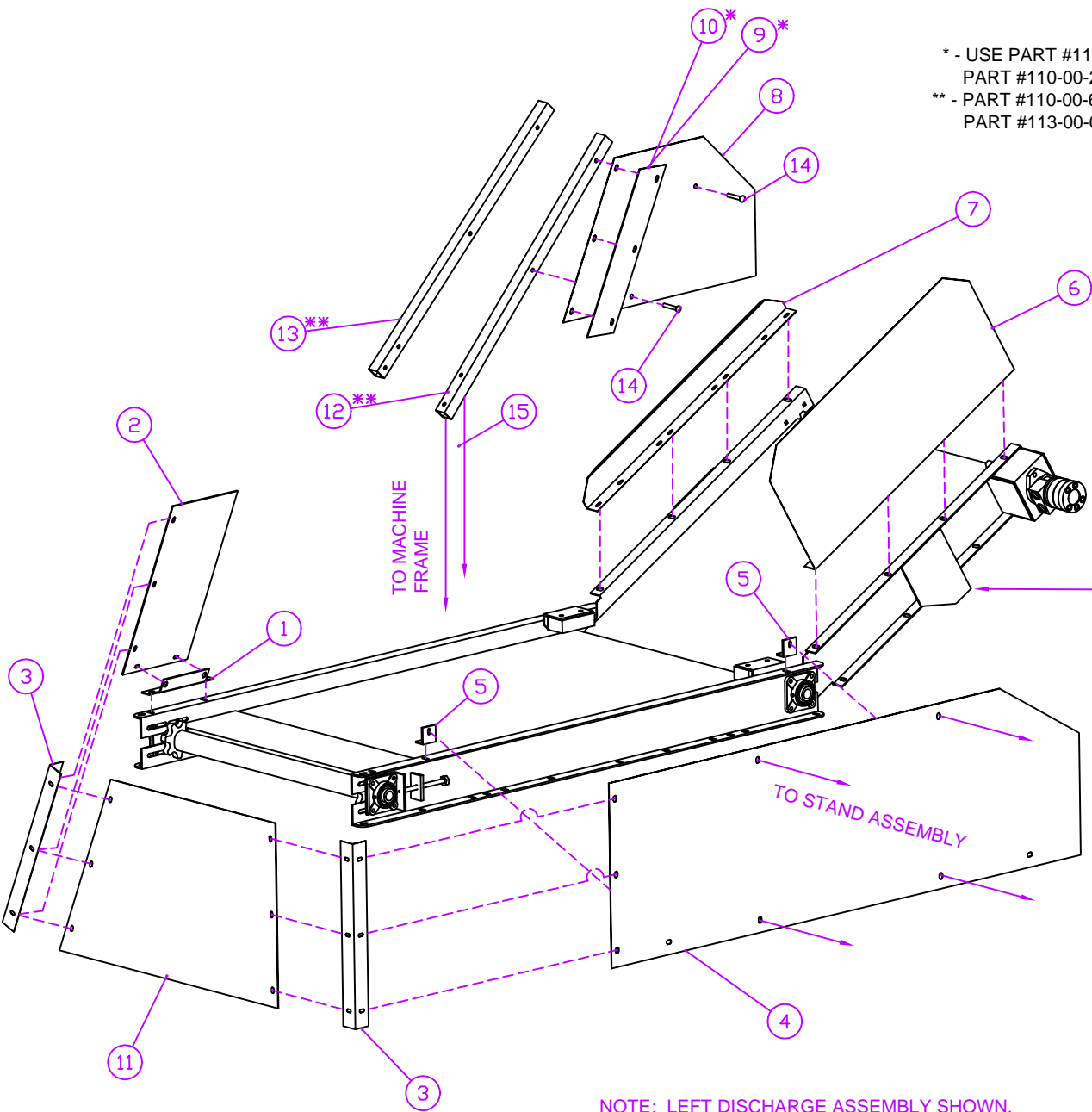

6' CONVEYOR W/ 41" WING EXTENSION (ASSEMBLY #060-08-01)

NOTE: LEFT DISCHARGE ASSEMBLY SHOWN.

19	Ø3/8" LOCKWASHERS	39	140-00-71
18	Ø3/8" FLAT WASHERS	39	140-00-66
17	Ø3/8" NUTS	39	140-00-85
16	Ø3/8" X 1" BOLTS	31	140-00-12
15	Ø3/8" X 2-1/2" BOLTS	2	140-00-14
14	Ø3/8" X 2-1/2" CARRIAGE BOLTS	2	140-00-18
13	WING SHIELD SUPPORT TUBE**	1	113-00-01
12	WING SHIELD SUPPORT TUBE**	1	110-00-62
11	CONVEYOR END SHIELD	1	110-00-61
10	RIGHT RUBBER SHIELD (WING END)*	1	110-00-28
9	LEFT RUBBER SHIELD (WING END)*	1	110-00-27
8	DRUM SIDE SHIELD (WING END)	1	110-00-26
7	WING SHIELD (DRUM SIDE)	1	110-00-24
6	WING SHIELD (STAND SIDE)	1	110-00-22
5	SHIELD SUPPORT CLIP	2	110-00-21
4	FRONT SHIELD (STAND SIDE)	1	110-00-17
3	SHIELD CORNER ANGLES	2	110-00-16
2	DRUM SIDE SHIELD	1	110-00-14
1	SHIELD MOUNT SUPPORT BRACKET	1	110-00-13
NO.	PART DESC.	QTY	PART NO.

PARTS LIST

DRAWN BY:	D. RODGERS	DATE:	JUN 2/00
MODEL:	ALL APPLICABLE	SHEET:	1 of 1
PART/ASSEMBLY NO.:	110-11-01		



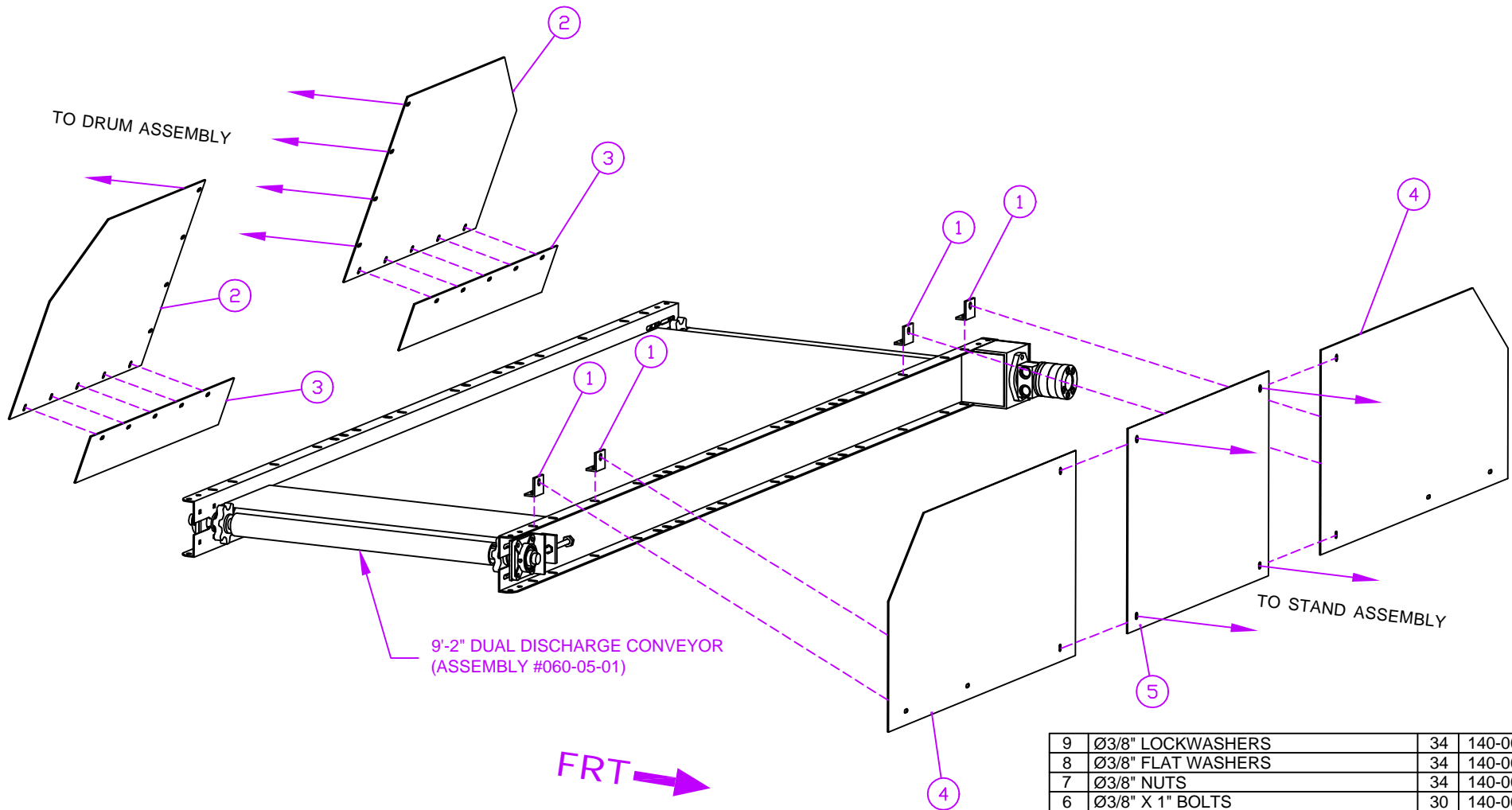

9	Ø3/8" LOCKWASHERS	34	140-00-71
8	Ø3/8" FLAT WASHERS	34	140-00-66
7	Ø3/8" NUTS	34	140-00-85
6	Ø3/8" X 1" BOLTS	30	140-00-12
5	CENTRE SHIELD (STAND SIDE)	1	110-00-41
4	END SHIELDS (STAND SIDE)	2	110-00-40
3	RUBBER GUARD	2	110-00-38
2	DRUM SIDE SHIELD	2	110-00-30
1	SHIELD SUPPORT CLIP	4	110-00-21
NO.	PART DESC.	QTY	PART NO.

PARTS LIST

DRAWN BY: D. RODGERS	DATE: JUN 9/00
MODEL: ALL APPLICABLE	SHEET: 1 of 1
PART/ASSEMBLY NO: 110-12-01	

JAY•LOR
Fabricating Inc

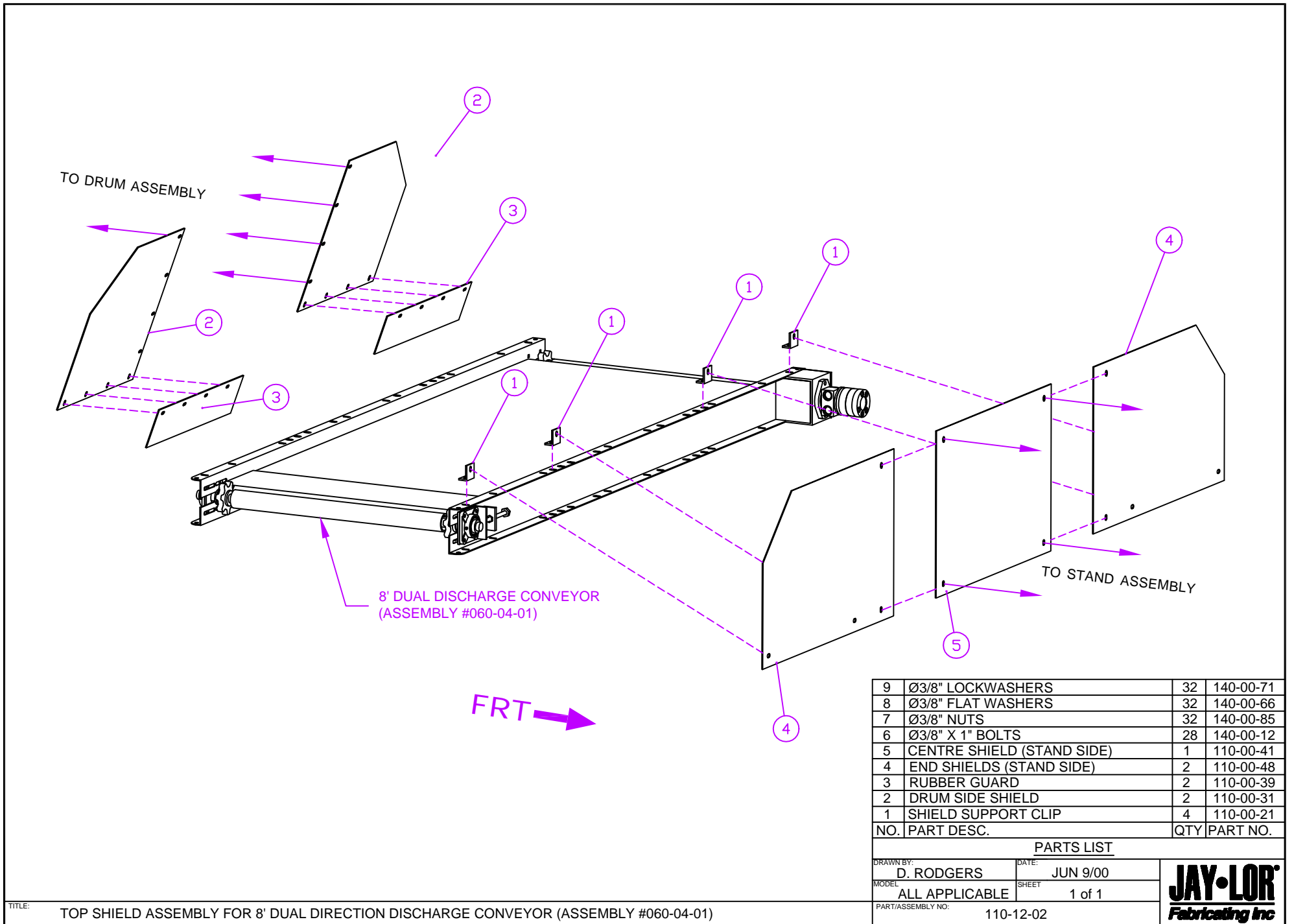

TO DRUM ASSEMBLY

TO STAND ASSEMBLY

8' DUAL DISCHARGE CONVEYOR
(ASSEMBLY #060-04-01)

FRT →

9	Ø3/8" LOCKWASHERS	32	140-00-71
8	Ø3/8" FLAT WASHERS	32	140-00-66
7	Ø3/8" NUTS	32	140-00-85
6	Ø3/8" X 1" BOLTS	28	140-00-12
5	CENTRE SHIELD (STAND SIDE)	1	110-00-41
4	END SHIELDS (STAND SIDE)	2	110-00-48
3	RUBBER GUARD	2	110-00-39
2	DRUM SIDE SHIELD	2	110-00-31
1	SHIELD SUPPORT CLIP	4	110-00-21
NO.	PART DESC.	QTY	PART NO.

PARTS LIST

DRAWN BY: D. RODGERS	DATE: JUN 9/00
MODEL: ALL APPLICABLE	SHEET: 1 of 1
PART/ASSEMBLY NO: 110-12-02	



TITLE: TOP SHIELD ASSEMBLY FOR 8' DUAL DIRECTION DISCHARGE CONVEYOR (ASSEMBLY #060-04-01)

8' OR 9'2" DUAL DIRECTION DISCHARGE CONVEYOR
(ASSEMBLY #060-04-01 OR #060-05-01)

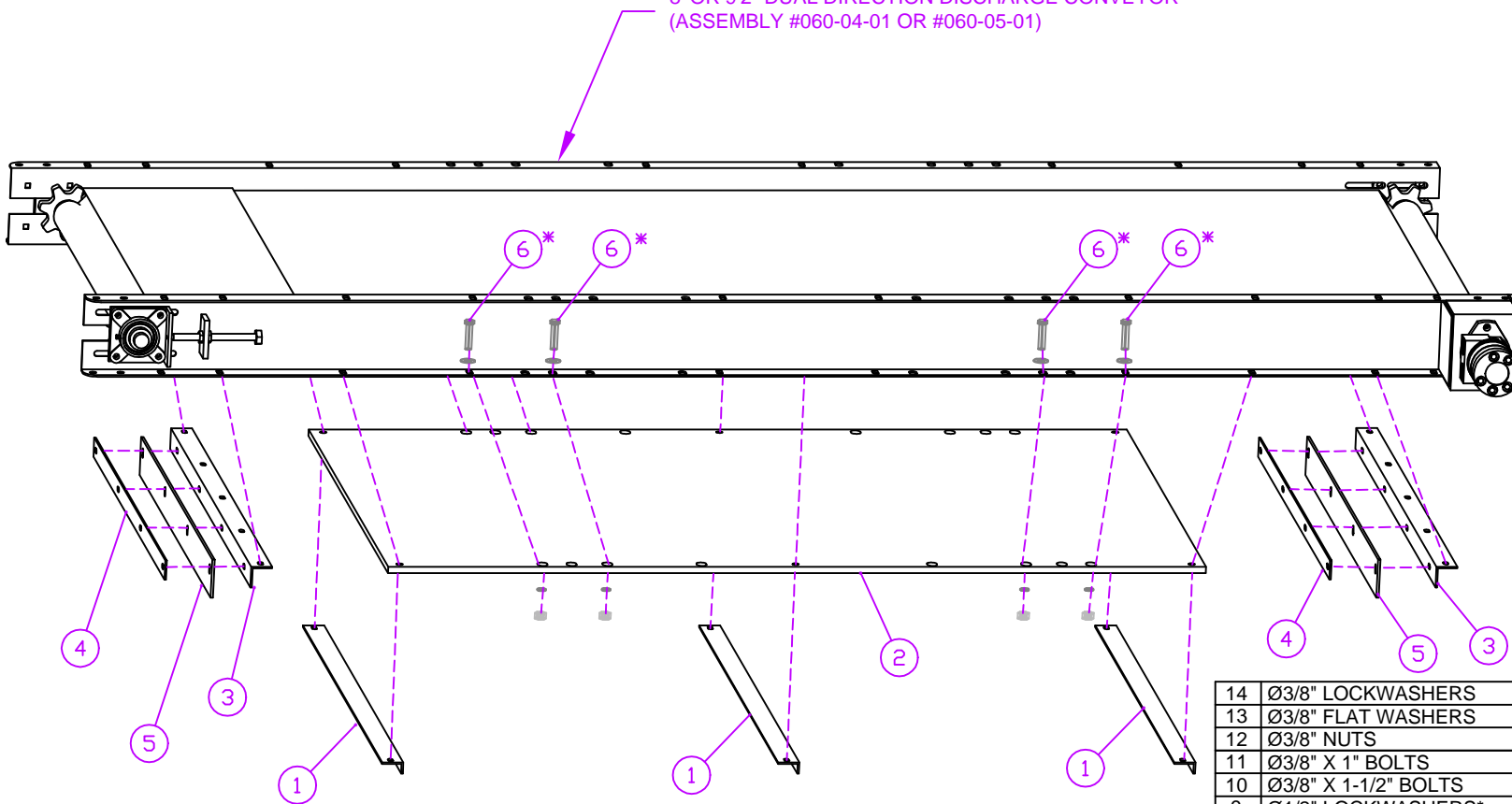

* - USED FOR MOUNTING CONVEYOR ASSEMBLY TO TYPICAL JAY-LOR FRAME UNIT.

14	Ø3/8" LOCKWASHERS	18	140-00-71
13	Ø3/8" FLAT WASHERS	18	140-00-66
12	Ø3/8" NUTS	18	140-00-85
11	Ø3/8" X 1" BOLTS	12	140-00-12
10	Ø3/8" X 1-1/2" BOLTS	6	140-00-17
9	Ø1/2" LOCKWASHERS*	8	140-00-72
8	Ø1/2" FLAT WASHERS*	8	140-00-67
7	CONVEYOR MOUNTING NUTS (Ø1/2")*	8	140-00-76
6	CONVEYOR BOLTS (Ø1/2" X 2")*	8	140-00-25
5	RUBBER FLAP	2	110-00-08
4	RUBBER FLAP RETAINER	2	110-00-07
3	RUBBER/PLASTIC SUPPORT ANGLE	2	110-00-06
2	PLASTIC SHIELD	1	110-00-11
1	SHIELD SUPPORT ANGLE	3	110-00-03
NO.	PART DESC.	QTY	PART NO.

PARTS LIST

DRAWN BY: D. RODGERS	DATE: JUN 9/00
MODEL: ALL APPLICABLE	SHEET: 1 of 1
PART/ASSEMBLY NO: 110-13-01	

JAY-LOR
Fabricating Inc

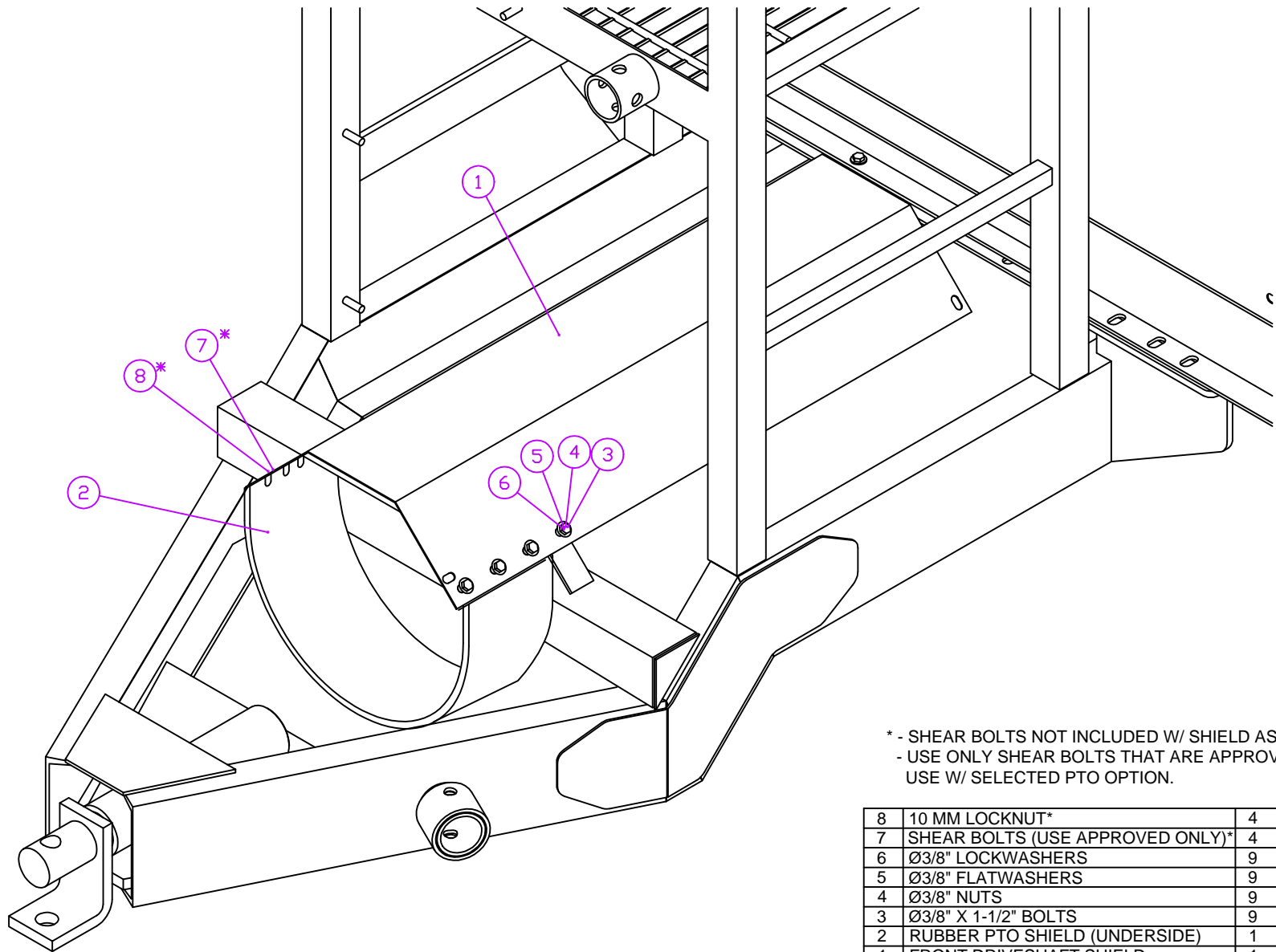

* - SHEAR BOLTS NOT INCLUDED W/ SHIELD ASSEMBLY.
 - USE ONLY SHEAR BOLTS THAT ARE APPROVED FOR USE W/ SELECTED PTO OPTION.

8	10 MM LOCKNUT*	4	140-00-86
7	SHEAR BOLTS (USE APPROVED ONLY)*	4	070-00-82
6	Ø3/8" LOCKWASHERS	9	140-00-71
5	Ø3/8" FLATWASHERS	9	140-00-66
4	Ø3/8" NUTS	9	140-00-85
3	Ø3/8" X 1-1/2" BOLTS	9	140-00-17
2	RUBBER PTO SHIELD (UNDERSIDE)	1	110-00-54
1	FRONT DRIVESHAFT SHIELD	1	113-00-03
NO.	PART DESC.	QTY	PART NO.

PARTS LIST

DRAWN BY: D. RODGERS		DATE: AUG 2/00	
MODEL: 2350		SHEET: 1 of 1	
PART/ASSEMBLY NO.:		113-05-01	

JAY-LOR
Fabricating Inc

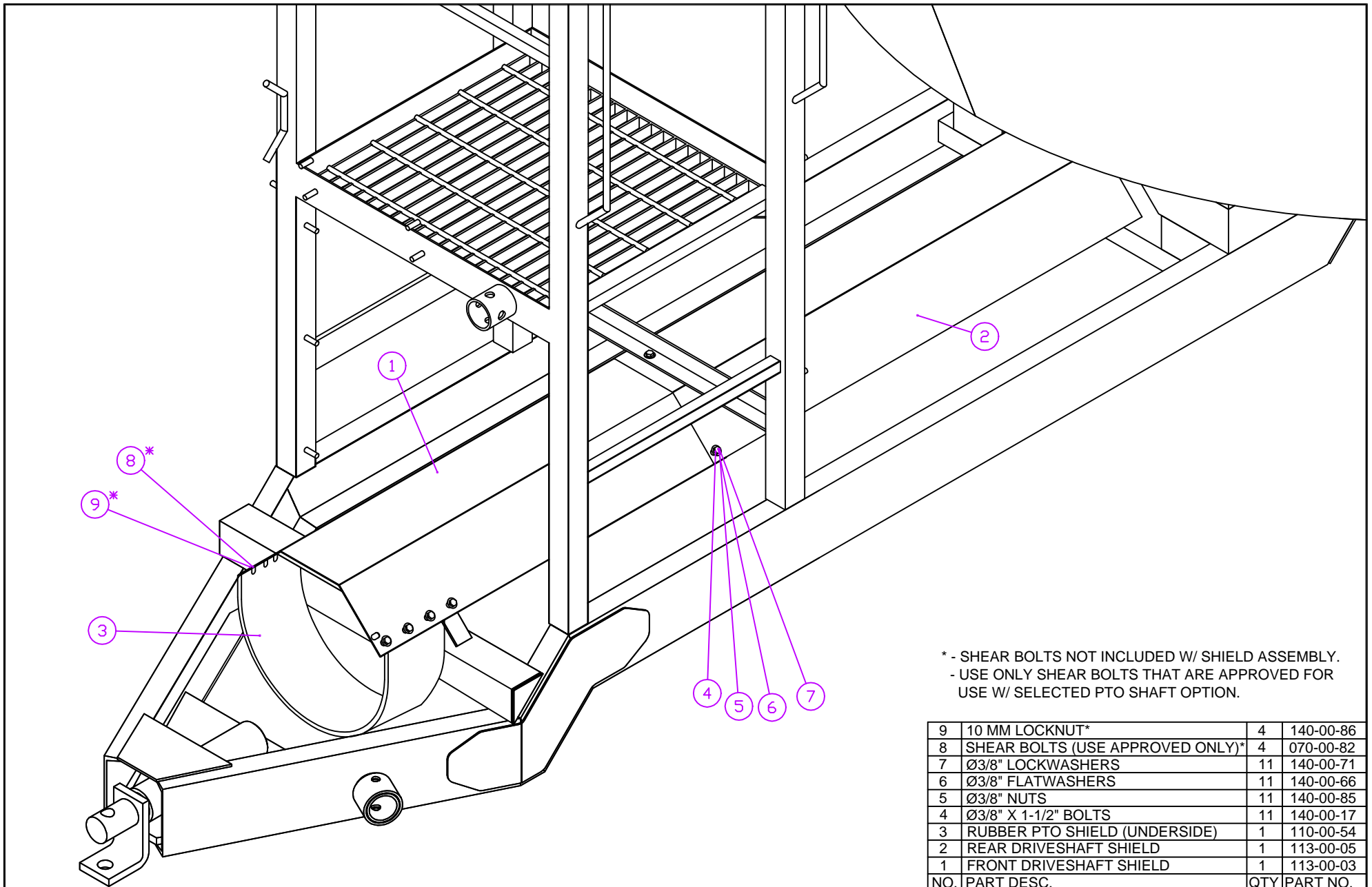

* - SHEAR BOLTS NOT INCLUDED W/ SHIELD ASSEMBLY.
 - USE ONLY SHEAR BOLTS THAT ARE APPROVED FOR USE W/ SELECTED PTO SHAFT OPTION.

9	10 MM LOCKNUT*	4	140-00-86
8	SHEAR BOLTS (USE APPROVED ONLY)*	4	070-00-82
7	Ø3/8" LOCKWASHERS	11	140-00-71
6	Ø3/8" FLATWASHERS	11	140-00-66
5	Ø3/8" NUTS	11	140-00-85
4	Ø3/8" X 1-1/2" BOLTS	11	140-00-17
3	RUBBER PTO SHIELD (UNDERSIDE)	1	110-00-54
2	REAR DRIVESHAFT SHIELD	1	113-00-05
1	FRONT DRIVESHAFT SHIELD	1	113-00-03
NO.	PART DESC.	QTY	PART NO.

PARTS LIST

DRAWN BY: D. RODGERS	DATE: AUG 2/00
MODEL: 2300/2350	SHEET: 1 of 1
PART/ASSEMBLY NO: 113-05-02	



JAY•LOR[®]

Cutter • Mixer • Feeder

12 – DECALS

"Putting the 'Total' into TMR"

JAY-LOR[®] Fabricating Inc.
RR # 2 Orton, Ontario, Canada, L0N 1N0 Tel: (519) 787-9353 Fax: (519) 787-7053

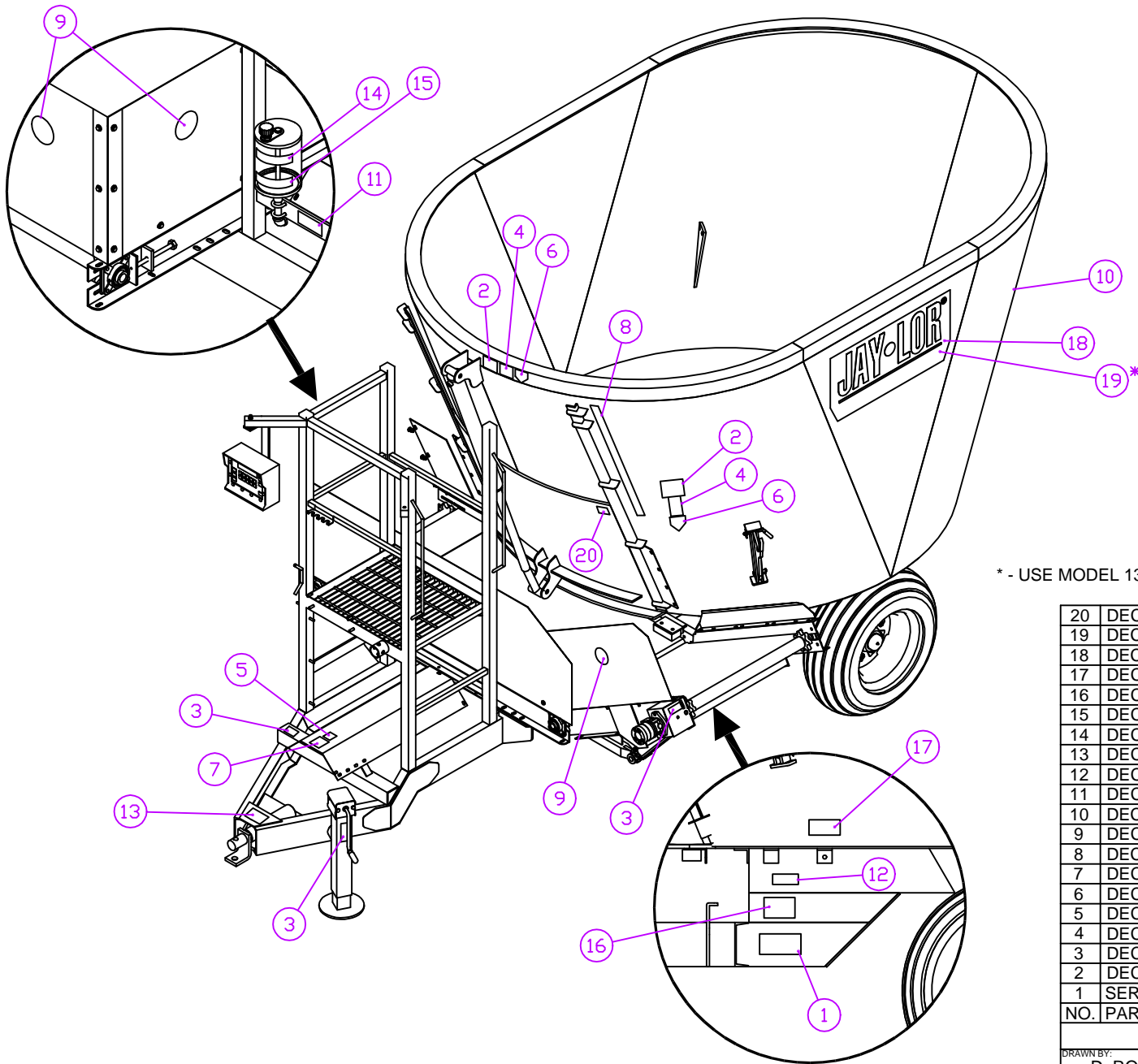

* - USE MODEL 1350 DECAL FOR MODELS PRIOR TO 2000 SERIES.

20	DECAL - DOOR HEIGHT ARROW	2	120-00-34
19	DECAL - MODEL 1350 (PRIOR TO 2350)*	2	120-00-03
18	DECAL - MODEL 2350	2	120-00-42
17	DECAL - GREASE 1 PUMP EVERY 8...	1	120-00-32
16	DECAL - PATENT PENDING	1	120-00-31
15	DECAL - MINIMUM OIL LEVEL	1	120-00-29
14	DECAL - MAXIMUM OIL LEVEL	1	120-00-28
13	DECAL - NOT FOR HIGHWAY TRAVEL...	1	120-00-24
12	DECAL - MADE IN CANADA	2	120-00-22
11	DECAL - USE ONLY ESSO OR MOBIL...	1	120-00-21
10	DECAL - SLOW MOVING VEHICLE	1	120-00-15
9	DECAL - "THINK" SAFETY	3	120-00-14
8	DECAL - DOOR OPENING MEASURE	2	120-00-13
7	DECAL - WARNING, OPERATE AT 540...	1	120-00-12
6	DECAL - DANGER, KEEP CHILDREN...	3	120-00-11
5	DECAL - DANGER, ROTATING...	1	120-00-09
4	DECAL - DANGER, TO PREVENT...	3	120-00-08
3	DECAL - GREASE	3	120-00-07
2	DECAL - WARNING, ROTATING KNIVES	3	120-00-06
1	SERIAL NUMBER PLATE	1	120-00-05
NO.	PART DESC.	QTY	PART NO.

PARTS LIST

DRAWN BY:	D. RODGERS	DATE:	AUG 2/00
MODEL:	2350	SHEET:	1 of 1
PART/ASSEMBLY NO.:	123-05-01		

JAY-LOR
Fabricating Inc

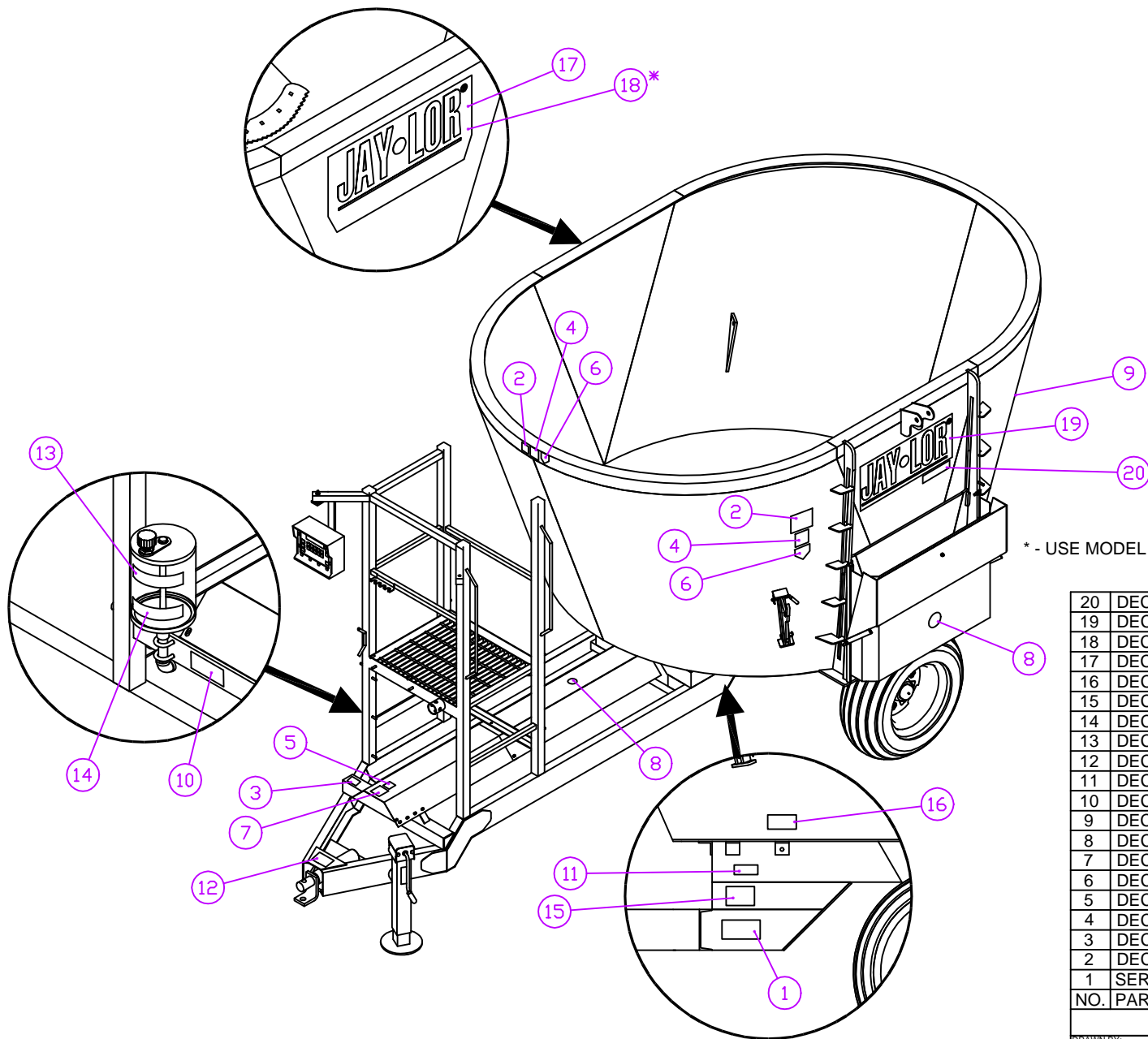

* - USE MODEL 1350 DECAL FOR MODELS PRIOR TO 2000 SERIES.

20	DECAL - MODEL 2350 (SMALL)	1	120-00-52
19	DECAL - C-SIDE GENERIC	1	120-00-50
18	DECAL - MODEL 1350 (PRIOR TO 2350)*	1	120-00-03
17	DECAL - MODEL 2350	1	120-00-42
16	DECAL - GREASE 1 PUMP EVERY 8...	1	120-00-32
15	DECAL - PATENT PENDING	1	120-00-31
14	DECAL - MINIMUM OIL LEVEL	1	120-00-29
13	DECAL - MAXIMUM OIL LEVEL	1	120-00-28
12	DECAL - NOT FOR HIGHWAY TRAVEL...	1	120-00-24
11	DECAL - MADE IN CANADA	2	120-00-22
10	DECAL - USE ONLY ESSO OR MOBIL...	1	120-00-21
9	DECAL - SLOW MOVING VEHICLE	1	120-00-15
8	DECAL - "THINK" SAFETY	2	120-00-14
7	DECAL - WARNING, OPERATE AT 540...	1	120-00-12
6	DECAL - DANGER, KEEP CHILDREN...	3	120-00-11
5	DECAL - DANGER, ROTATING...	1	120-00-09
4	DECAL - DANGER, TO PREVENT...	3	120-00-08
3	DECAL - GREASE	2	120-00-07
2	DECAL - WARNING, ROTATING KNIVES	3	120-00-06
1	SERIAL NUMBER PLATE	1	120-00-05
NO.	PART DESC.	QTY	PART NO.

PARTS LIST

DRAWN BY: D. RODGERS	DATE: AUG 2/00
MODEL: 2350	SHEET: 1 of 1
PART/ASSEMBLY NO.: 123-05-02	

JAY-LOR
Fabricating Inc

TITLE: COMPLETE DECAL PACKAGE FOR MODEL 2350 W/ CENTER-SIDE DOOR DISCHARGE (MODEL 1350 PRIOR TO 2000 SERIES)

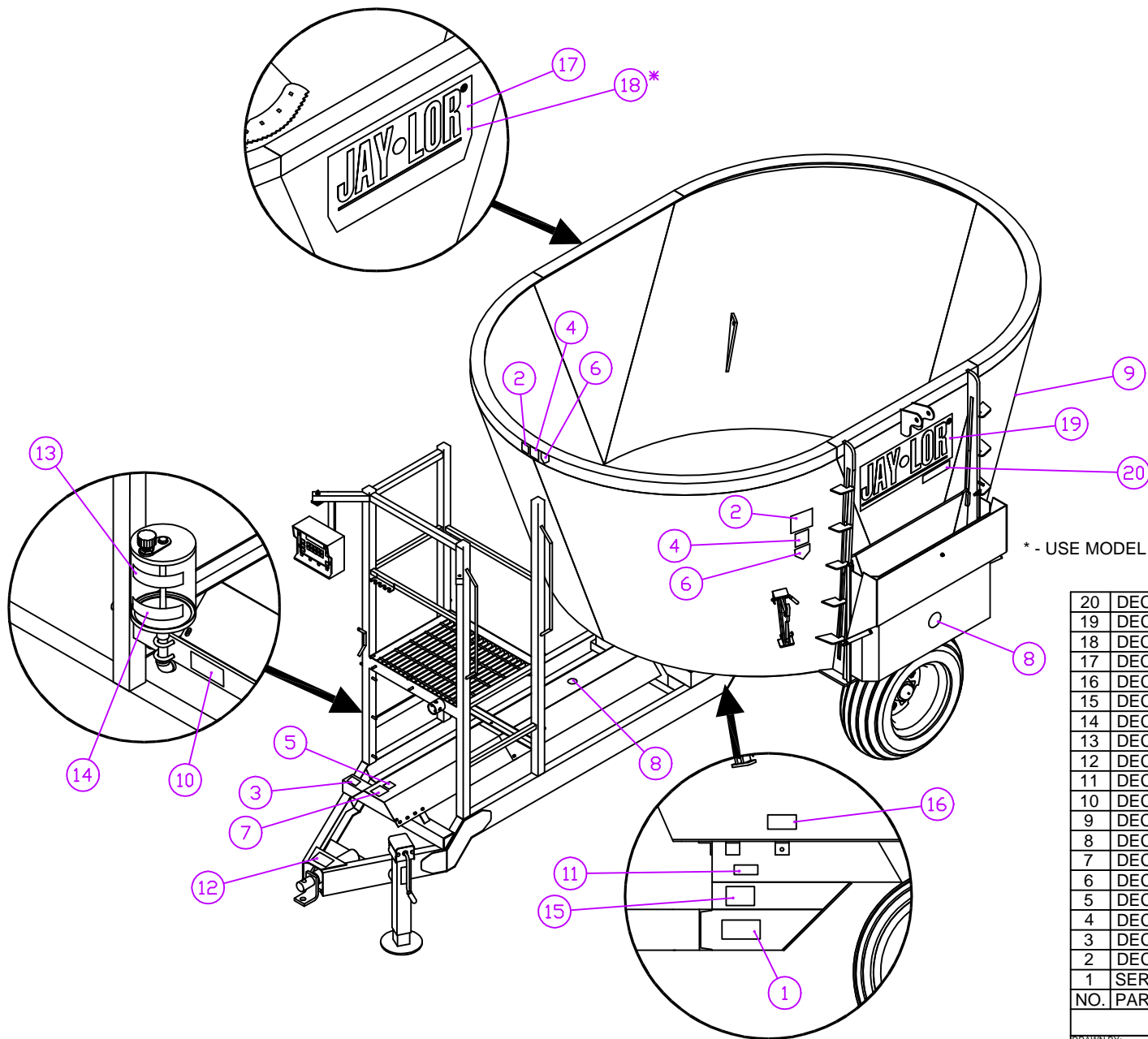

* - USE MODEL 1300 DECAL FOR MODELS PRIOR TO 2000 SERIES.

20	DECAL - MODEL 2300 (SMALL)	1	120-00-51
19	DECAL - C-SIDE GENERIC	1	120-00-50
18	DECAL - MODEL 1300 (PRIOR TO 2300)*	1	120-00-04
17	DECAL - MODEL 2300	1	120-00-41
16	DECAL - GREASE 1 PUMP EVERY 8...	1	120-00-32
15	DECAL - PATENT PENDING	1	120-00-31
14	DECAL - MINIMUM OIL LEVEL	1	120-00-29
13	DECAL - MAXIMUM OIL LEVEL	1	120-00-28
12	DECAL - NOT FOR HIGHWAY TRAVEL...	1	120-00-24
11	DECAL - MADE IN CANADA	2	120-00-22
10	DECAL - USE ONLY ESSO OR MOBIL...	1	120-00-21
9	DECAL - SLOW MOVING VEHICLE	1	120-00-15
8	DECAL - "THINK" SAFETY	2	120-00-14
7	DECAL - WARNING, OPERATE AT 540...	1	120-00-12
6	DECAL - DANGER, KEEP CHILDREN...	3	120-00-11
5	DECAL - DANGER, ROTATING...	1	120-00-09
4	DECAL - DANGER, TO PREVENT...	3	120-00-08
3	DECAL - GREASE	2	120-00-07
2	DECAL - WARNING, ROTATING KNIVES	3	120-00-06
1	SERIAL NUMBER PLATE	1	120-00-05
NO.	PART DESC.	QTY	PART NO.

PARTS LIST

DRAWN BY: D. RODGERS	DATE: AUG 2/00
MODEL: 2300	SHEET: 1 of 1
PART/ASSEMBLY NO.: 123-05-03	

JAY-LOR
Fabricating Inc

TITLE: COMPLETE DECAL PACKAGE FOR MODEL 2300 W/ CENTER-SIDE DOOR DISCHARGE (MODEL 1300 PRIOR TO 2000 SERIES)

JAY•LOR[®]

Cutter • Mixer • Feeder

SERVICE DEPARTMENT FORMS

"Putting the 'Total' into TMR"

JAY-LOR[®] Fabricating Inc.
RR # 2 Orton, Ontario, Canada, L0N 1N0 Tel: (519) 787-9353 Fax: (519) 787-7053

Parts Order #: _____

Date: _____



Dealer:	Customer:
IRS#:	IRS#:
For Mixer Model #:	Mixer Serial #:

Quantity	Part/Assembly Number	Description

Carrier Preferred: _____ Carrier Account #: _____ Prepaid

Level of Service Required: Next Day 2nd Day 3rd Day Ground

Notes: _____

Reference: _____ Signed: _____

SHIP TO: <input type="checkbox"/> Dealer <input type="checkbox"/> Customer

WARRANTY REQUEST FORM

WRF#: _____



Date: _____

Dealer/Customer Name: _____

Tel: _____

Address: _____

Fax: _____

City/State/Zip: _____

IRS #: _____

Machine Model #: _____

Machine Serial #: _____

QTY	Defective Part	Part # (if applicable)	Problem

Shipping Details:

Preferred Carrier: _____ Carrier Acc't #: _____

Level of service Req'd: Next day 2nd day 3rd day Ground Service

Ordered by: _____

IRS #: _____

Ship To Address:

Address: _____

City/State/Tel: _____

Notes: _____

Signature: _____ Printed Name: _____