

Benefits of FastMove

- Handles loads up to 100 kg each
- Speed up to 4.0m/s
- High Throughput
- Flexibility

Complete set of modular elements

- Belt Transfer

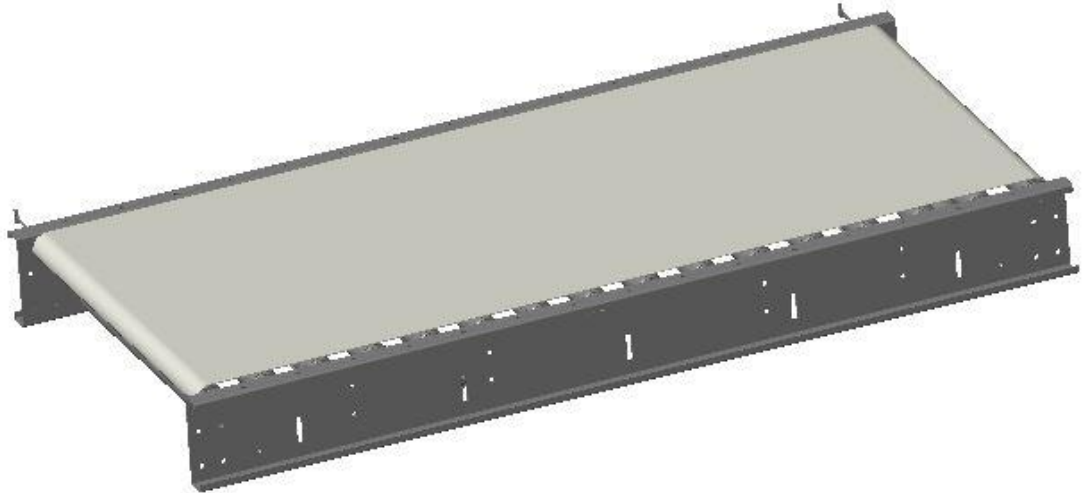

- Roller Transfer

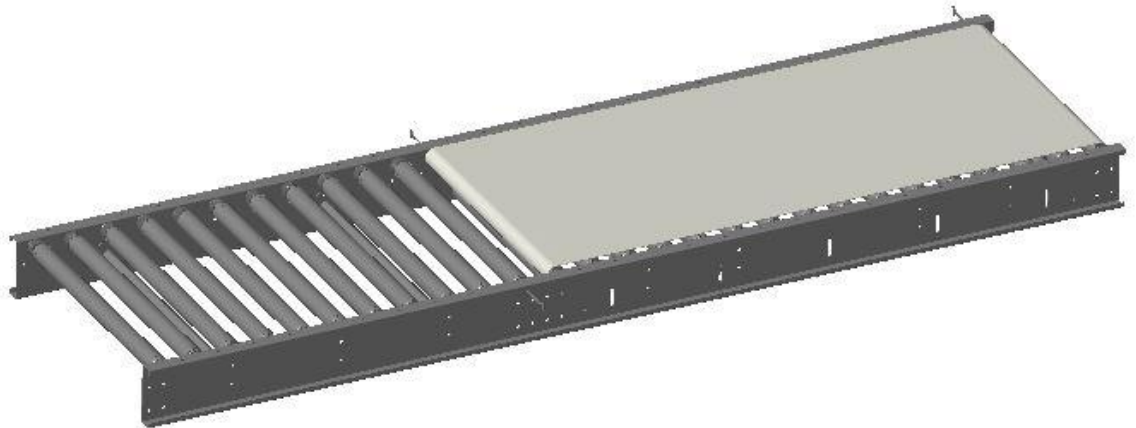

- Climbing Transfer

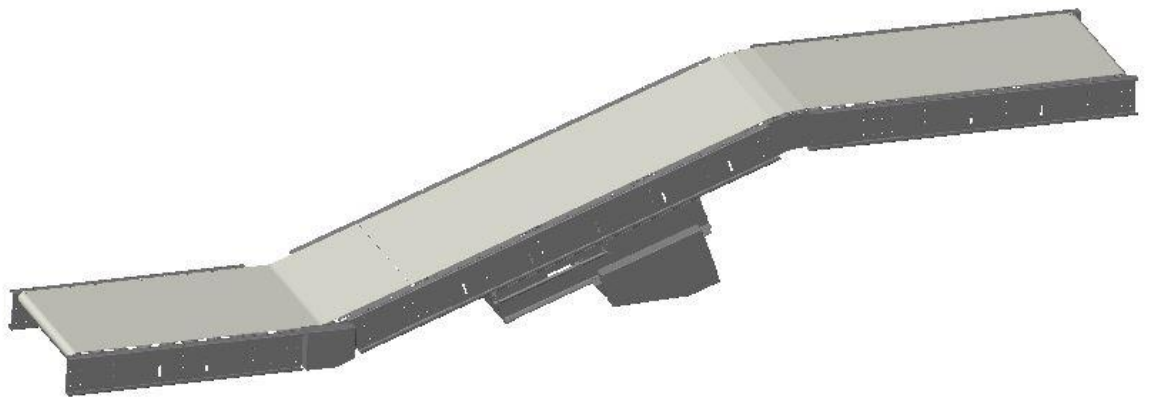

- Curve Transfer



- DTU

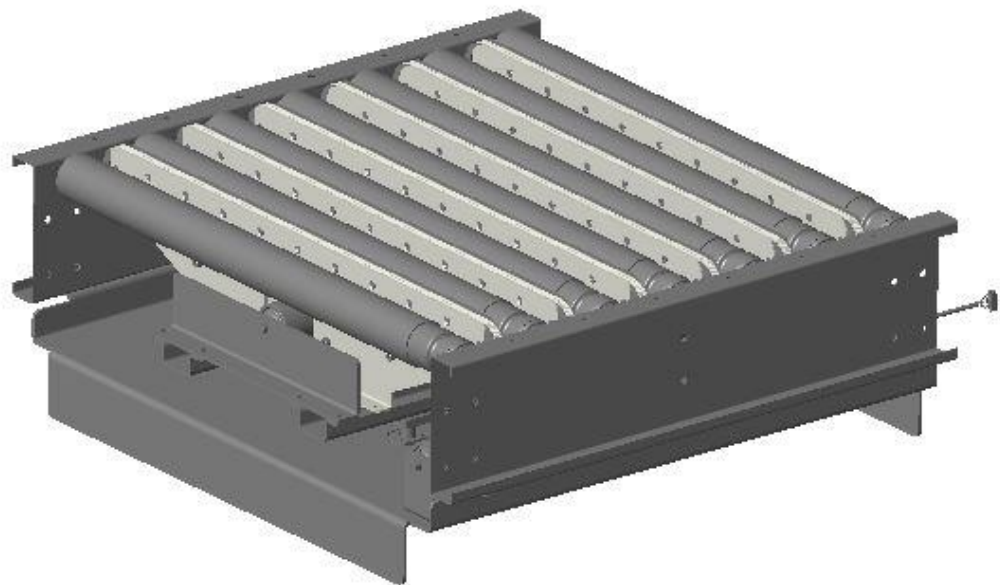

- Split Transfer

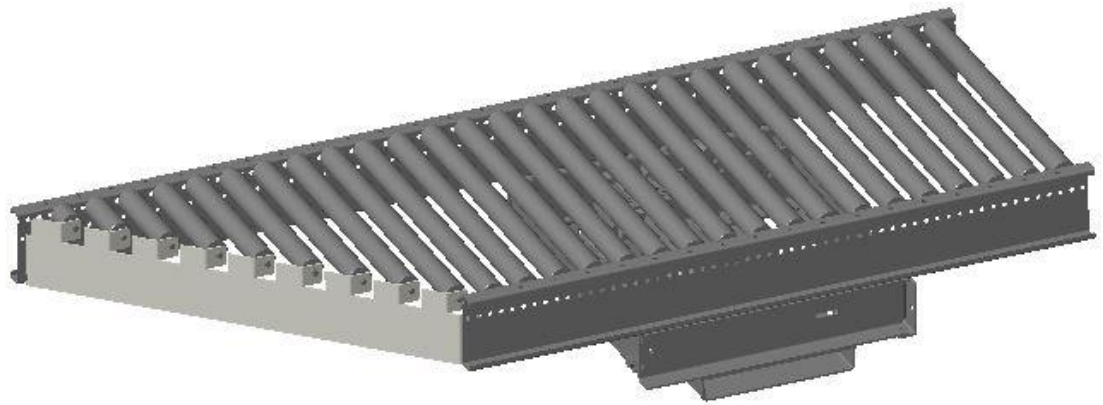

Benefits of IntelMove

- Handles loads up to 1,500 kg each
- Speed up to 0.5m/s
- High Throughput
- Flexibility

Complete set of modular elements

- Chain Conveyor

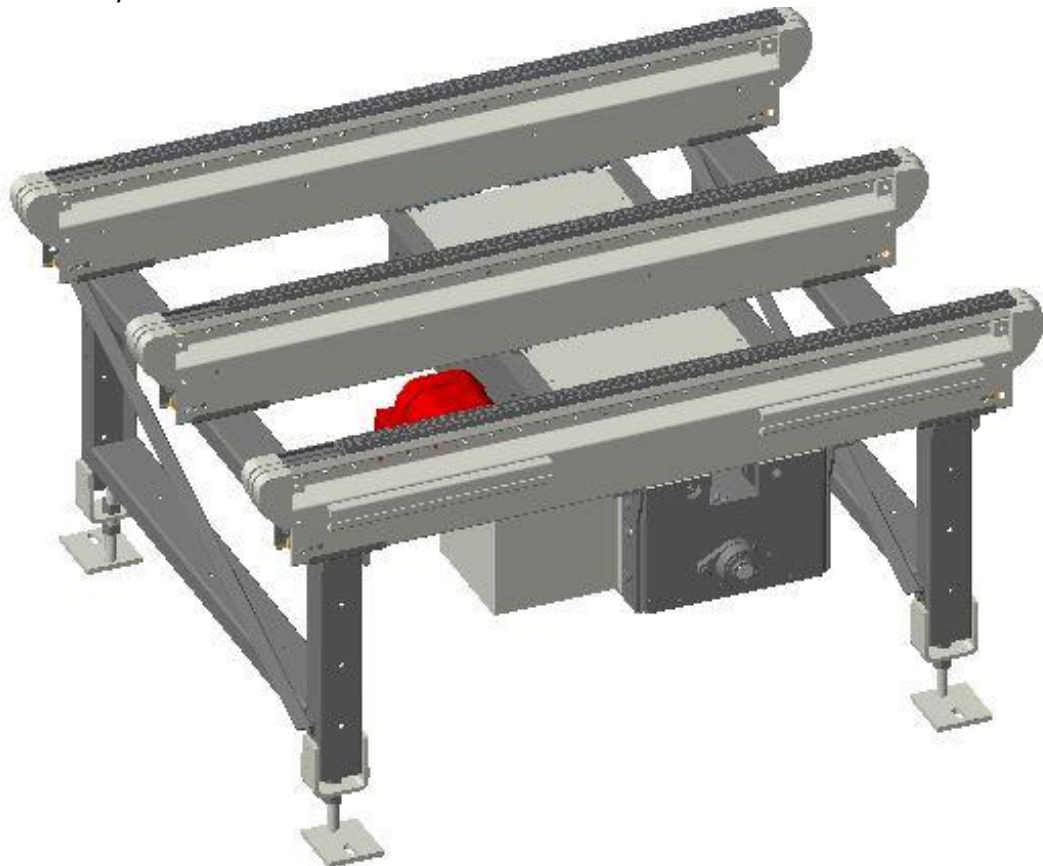

- Roller Conveyor

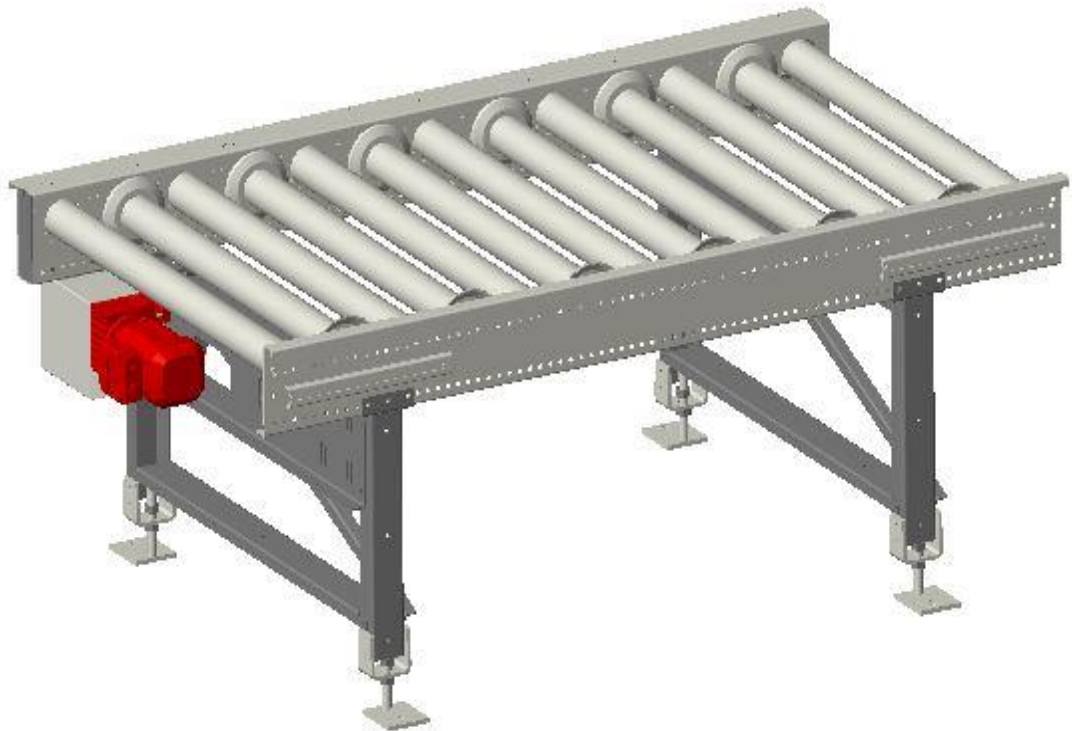

- Transfer Units

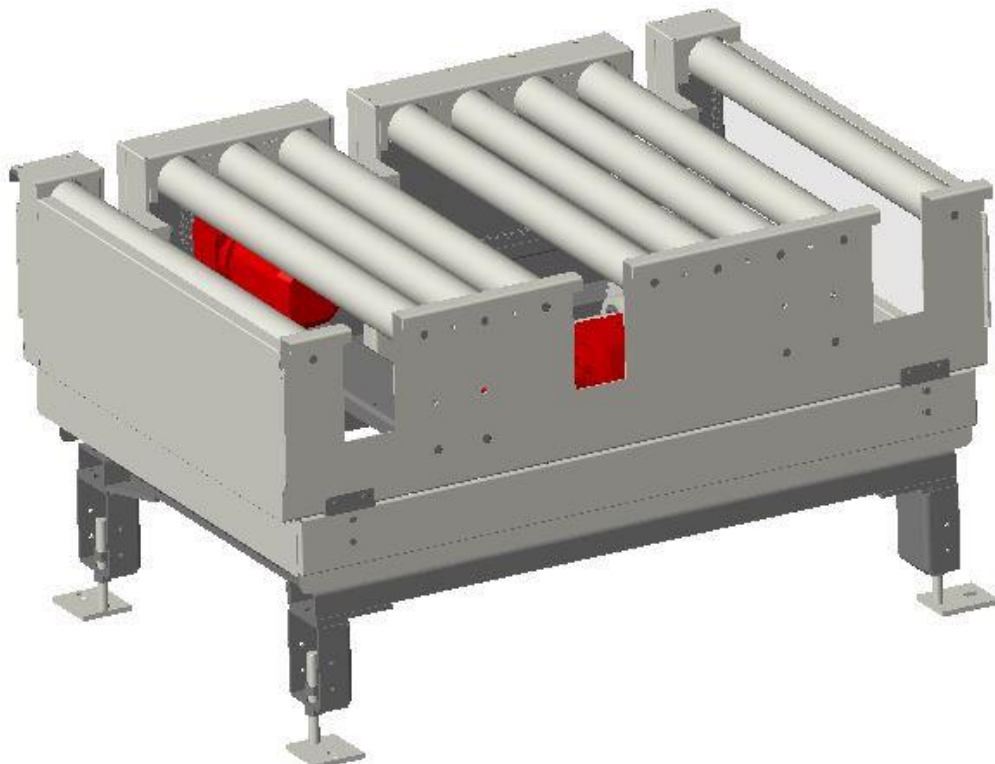

- Turn Table

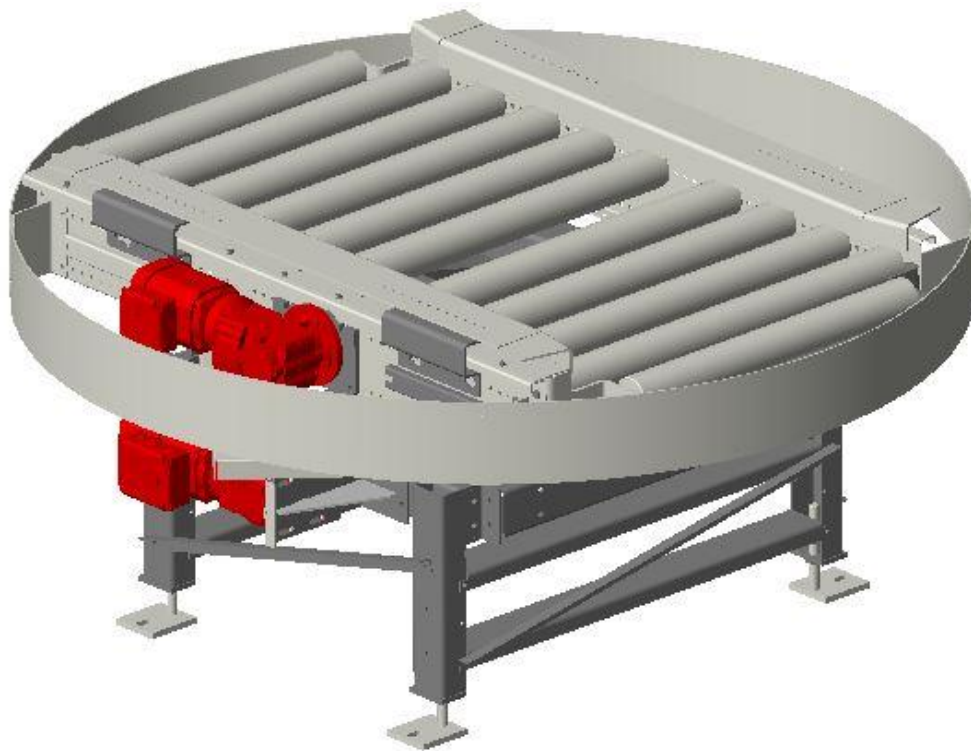

- Plastic Slat Conveyor

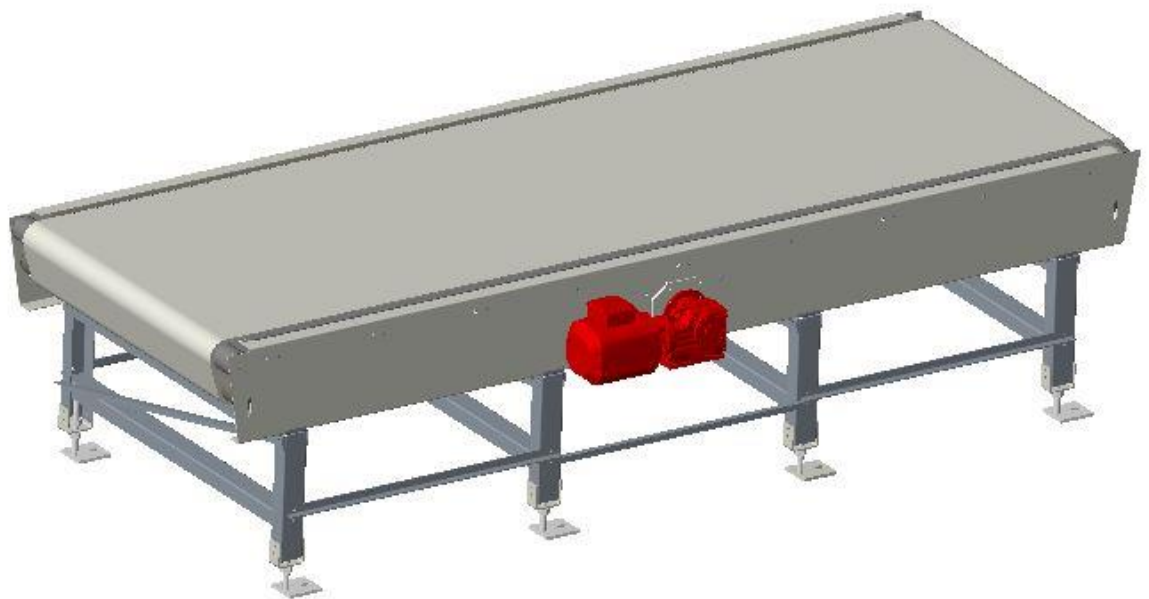

- Pallet Magazine

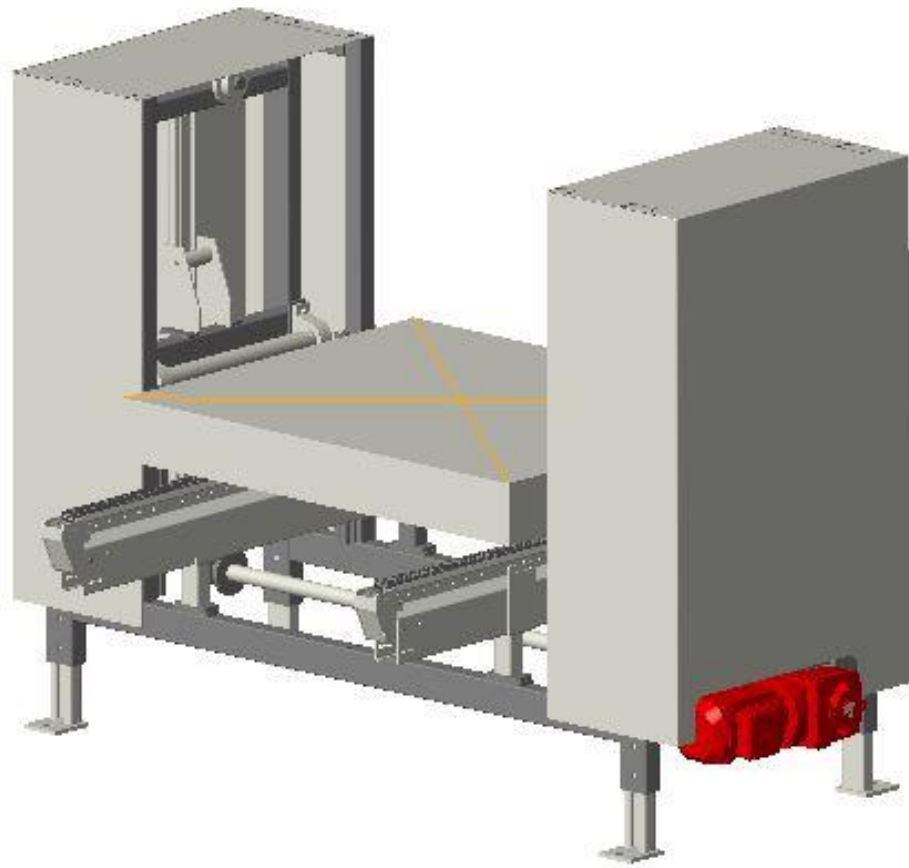

- Shuttle Car

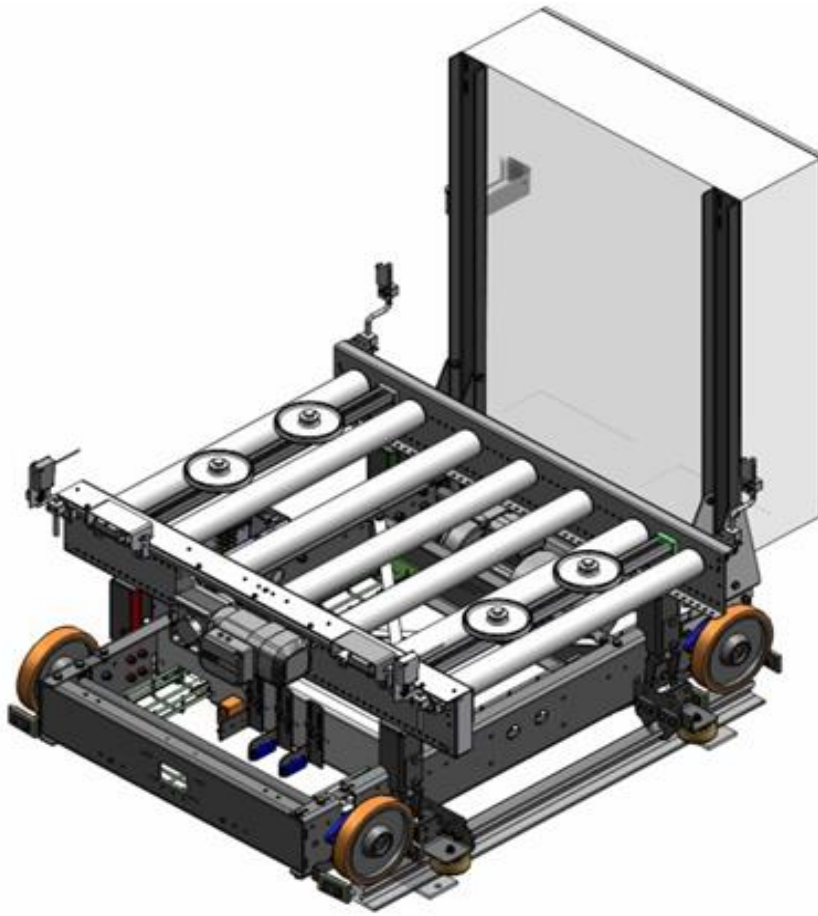

- Low Lift

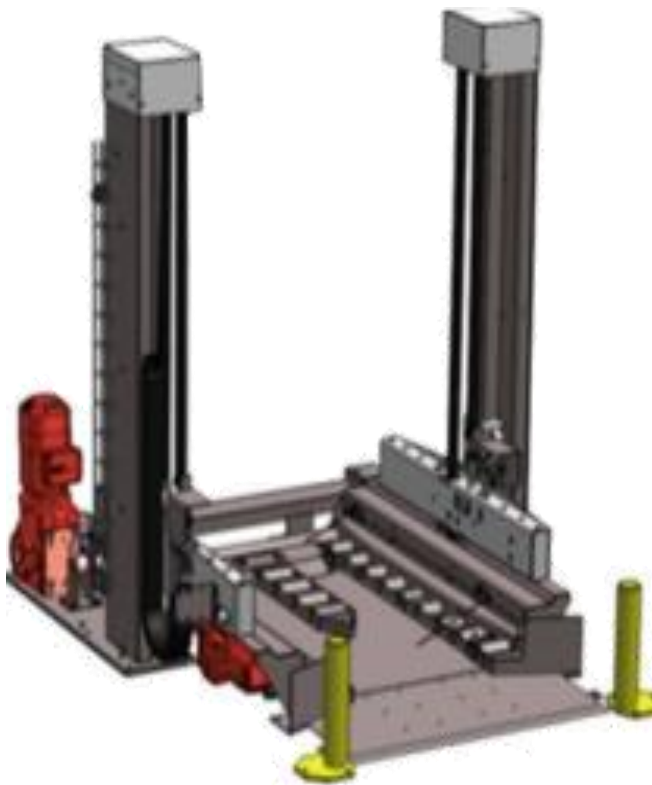

- Mid-Size Lift

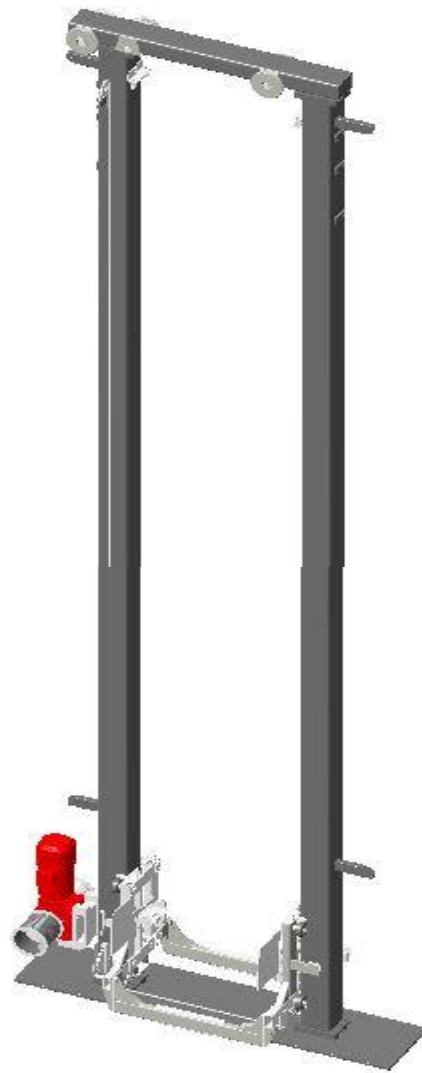
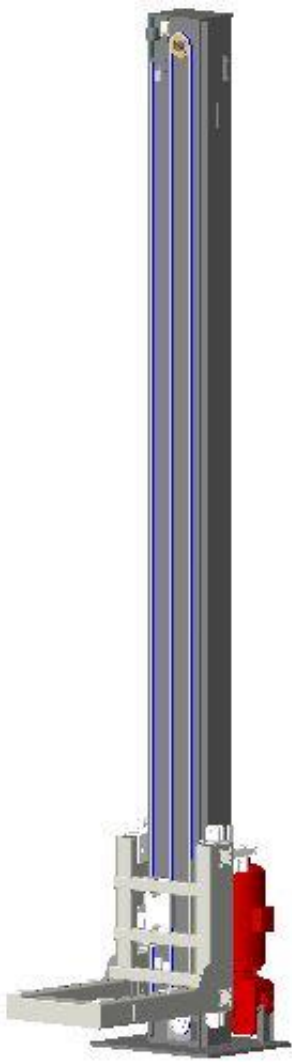

- Pick-up/deposit station for FLT

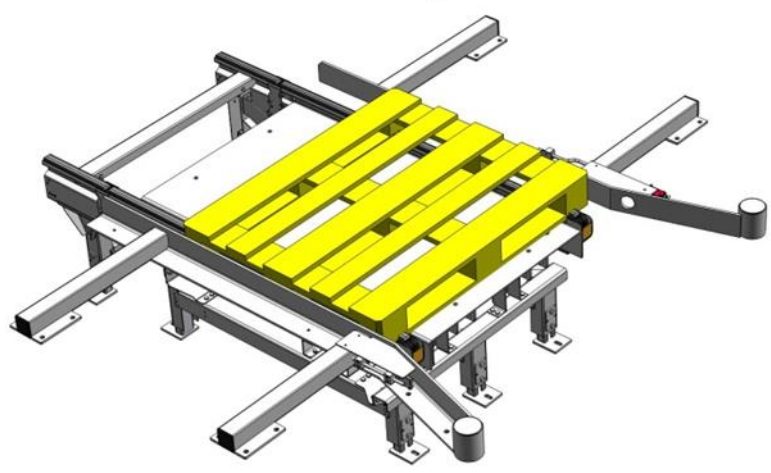
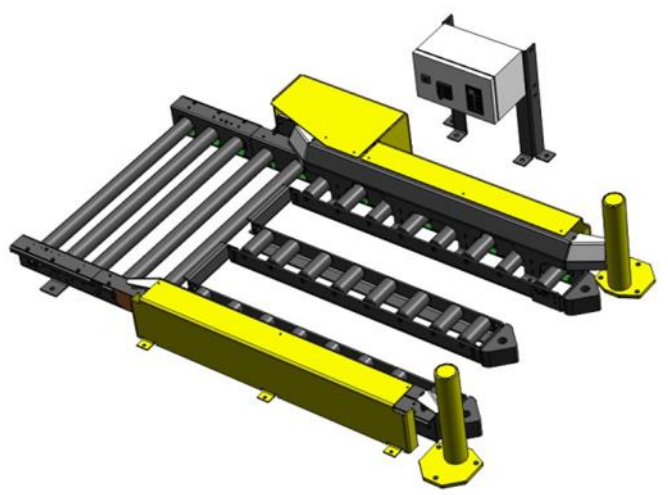
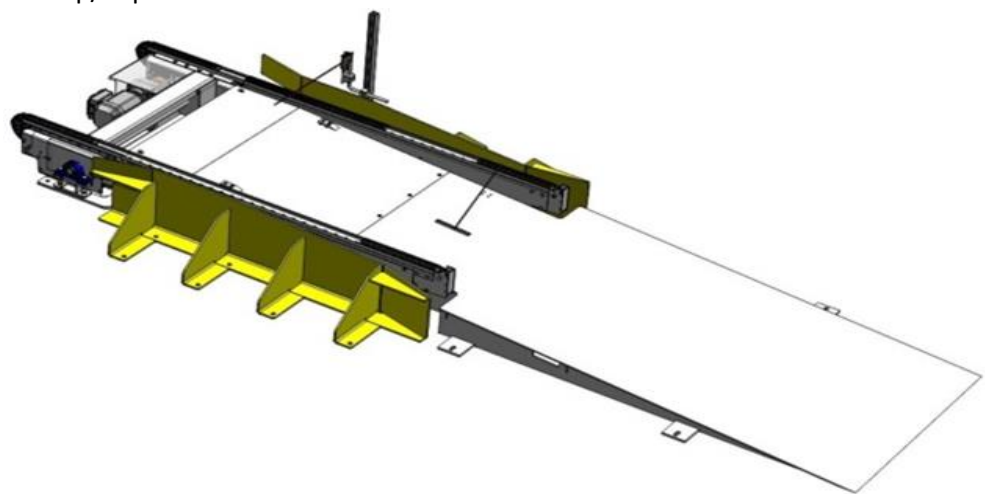

- Profile Check

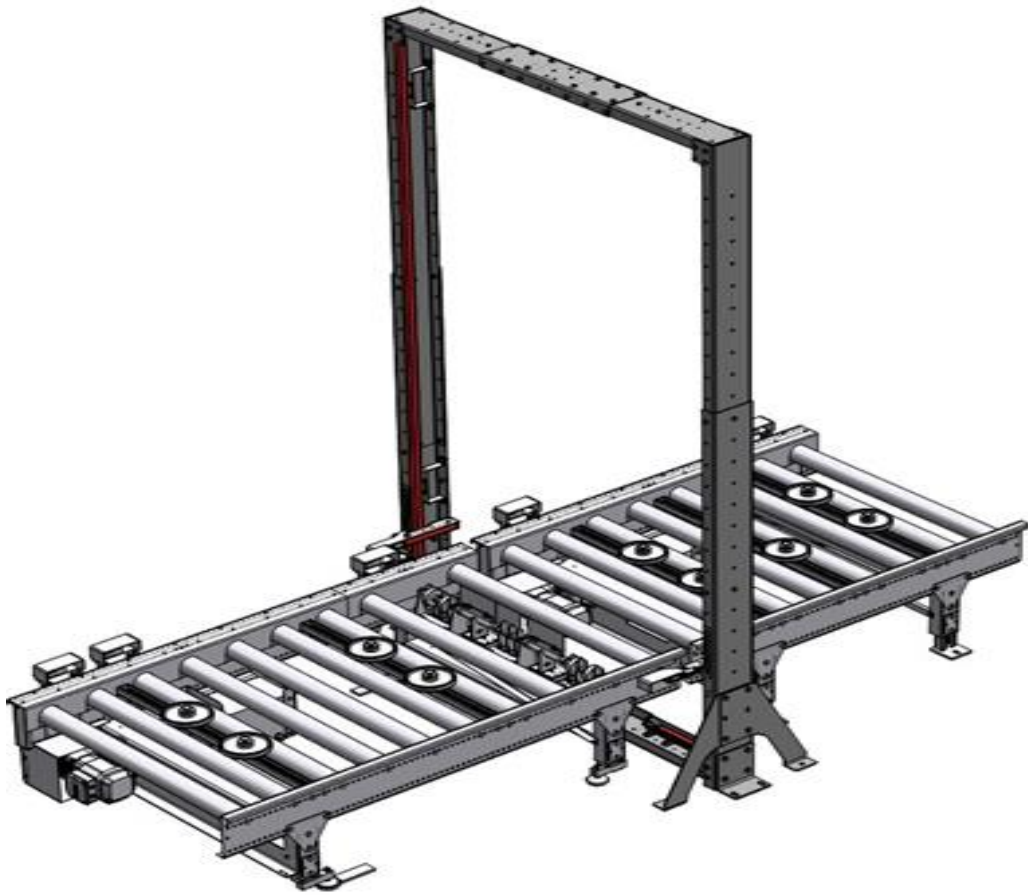

- Accessories

