

CHIP-8 Classic Manual

Revision 1.3
9th March, 2019

www.CHIP-8.com

CHIP-8 INTRODUCTION

CHIP-8 was originally developed by RCA Labs (1972) to allow users of low cost microcomputers to design their own video game programs without the tedious task of writing assembly language programs. RCA's original Computer was called the Cosmac VIP. It used an 8 Bit processor (1802) running at 1.76 Mhz. Sound consisted of one fixed tone, and data storage utilized a cassette recorder.

This modern day implementation of a CHIP-8 Computer has a Flash based Interpreter that is resident within the boards Operating System.

The Hardware specifications are:

- ◆ 32 BIT Microcontroller running at 48MHz.
- ◆ 64x32 pixel monochrome Composite Video Display.
- ◆ Sound Generator – 30 Tones.
- ◆ RS485 Serial Port.
- ◆ Hexadecimal Keypad Interface.
- ◆ EEPROM Option board – CHIP-8 supported Load and Save functions.
- ◆ Single 5VDC Supply, using a 2.1x5.5 DC plug
- ◆ Small 120x90mm PCA footprint.

The CHIP-8 language has 37 instructions, including 3 new instructions which support RS485 Serial Communications, and Sound Generator Pitch changes.

The language uses 16 one-byte registers (V0 – VF), which can be manipulated with a variety of arithmetic/logic and conditional branch instructions. A 12 BIT Instruction pointer (I) indexes memory locations for load/store and display instructions. This allows multiple sets of variables or array processing. Subroutine nesting is implemented to 32 levels.



Figure 1: CHIP-8 Interface Connectors



Figure 2: CHIP-8 Hexadecimal Keypad

START UP

The CHIP-8 board has three modes of operation – Command Mode, Edit Mode, and Program mode. When power is first applied, you start off in Command mode. The display shows random data within the active display area.

The white Status Bar, located towards the bottom of the screen shows the hexadecimal numbers 4457. This is the normal default value prior to the address being changed.

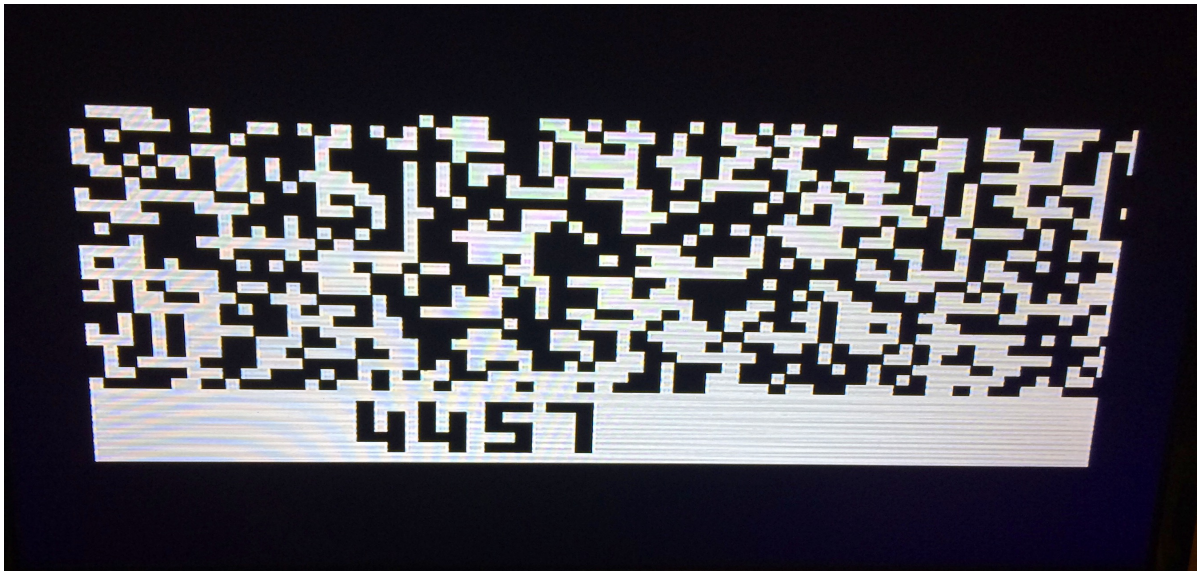

Figure 3: CHIP-8 Display

STATUS BAR

The white status bar shows the current memory address being pointed to by the CHIP-8 program counter (PC). It is a four digit Hexadecimal number. The value can range from 0000 to FFFF Hex.

When in edit mode a two digit Hexadecimal number is displayed to the right of the memory address. This value represents the data being pointed to by the program counter.

COMMANDS

You must be in Command mode to use the Function keys.

Pressing the F2 key will reset the monitor. The boards Red LED will light. Program data is not lost. When in edit mode, pressing the F2 key allows the monitor to break out and go back to command mode.

Pressing the F1 key followed by the 0 key will place the monitor into edit mode. It is this mode that allows a program to be stored in memory. Pressing the F1 key when in edit mode will increment the address of the program.

Pressing the F1 key followed by the 1 key will save a program to EEPROM. All data between addresses 0200 Hex and 09FF Hex will be saved.

Pressing the F1 key followed by the 2 key will load a previously saved program to CHIP-8 memory beginning at address 0200 Hex.

Pressing the F1 key followed by the 3 key will tell the monitor to run the CHIP-8 program starting at address 0200 Hex. This is the third mode of operation.

Commands (F1,1) and (F1,2) rely on the EEPROM Option board being installed .

CHIP-8 INSTRUCTION SET

Stored Code	Mnemonic	Description
0000	NOP	No Operation.
00E0	ERASE	Clear the Screen.
00EE	RETURN	Return from Subroutine.
1MMM	GOTO MMM	Jump to location MMM.
2MMM	DO MMM	Call Subroutine.
3XKK	SKF VX=KK	Skip next Instruction if VX=KK.
4XKK	SKF VX≠KK	Skip next Instruction if VX≠KK.
5XY0	SKF VX=VY	Skip next Instruction if VX=VY.
6XKK	VX=KK	Assign Hex value KK to Register VX.
7XKK	VX=VX+KK	Add KK to VX.
8XY0	VX=VY	Copy VY to VX.
8XY1	VX=VX VY	Logical OR VX with VY.
8XY2	VX=VX.VY	Logical AND VX with VY.
8XY3	VX=VX XOR VY	Logical XOR VX with VY.
8XY4	VX=VX+VY	Add VY to VX. If result >FF, then VF=1.
8XY5	VX=VX-VY	Subtract VY. If VX<VY, then VF=0.
9XY0	SKF VX≠VY	Skip next Instruction if VX≠VY.
AMMM	I=MMM	Set memory Index Pointer to MMM.
BMMM	GOTO MMM+V0	Jump to location MMM+V0.
CXKK	VX=RND.KK	Get random byte, then AND with KK.
DXYN	SHOW N@VX,VY	Display N-byte pattern at (VX,VY).
EX9E	SKF VX=KEY	Skip if key down =VX. No wait.
EXA1	SKF VX≠KEY	Skip if key down ≠VX. No wait.
F000	STOP	Jump to Monitor (CHIPOS).
FX07	VX=TIME	Get current timer value.
FX0A	VX=KEY	Input Hex key code. Wait for key down.
FX15	TIME=VX	Initialize Timer. 01=20 mS.
FX17	PITCH=VX	Set the Pitch of the Tone Generator to VX.
FX18	TONE=VX	Sound Tone for 20 times VX milliseconds.
FX1E	I=I+VX	Add VX to Memory Pointer.
FX29	I=DSP,VX	Set Pointer to show VX (LS digit).
FX33	MI=DEQ,VX	Store 3 digit decimal equivalent of VX.
FX55	MI=VO:VX	Store V0 through VX at I. I=I+X+1.
FX65	V0:VX=MI	Load V0 through VX at I. I=I+X+1.
FX70	RS485=VX	Send data in VX to RS485 Port.
FX71	VX=RS485	Waits for received RS485 data. Place in VX.
FX72	BAUD=VX	Set RS485 Baud rate.

BAUD RATES

Data	BAUD Rate
0x00	110 BAUD
0x01	300 BAUD
0x02	1200 BAUD
0x03	2400 BAUD
0x04	4800 BAUD
0x05	9600 BAUD
0x06	19200 BAUD
0x07	38400 BAUD
0x08	57600 BAUD
0x09	115200 BAUD

The default Baud rate is 9600.

Note: When using the FX71 instruction to receive RS485 data, the transmit data must be delayed by a minimum of 300mS to allow for a successful read to occur.

PITCH VALUES

Data	Note	Frequency
0x00	No Tone	0 Hz
0x01	Note C2	65 Hz
0x02	Note D2	73 Hz
0x03	Note E2	82 Hz
0x04	Note F2	87 Hz
0x05	Note G2	98 Hz
0x06	Note A3	110 Hz
0x07	Note B3	123 Hz
0x08	Note C3	131 Hz
0x09	Note D3	147 Hz
0x0A	Note E3	165 Hz
0x0B	Note F3	175 Hz
0x0C	Note G3	196 Hz
0x0D	Note A4	220 Hz
0x0E	Note B4	247 Hz
0x0F	Note C4	262 Hz
0x10	Note D4	294 Hz
0x11	Note E4	330 Hz
0x12	Note F4	349 Hz
0x13	Note G4	392 Hz
0x14	Note A5	440 Hz
0x15	Note B5	494 Hz
0x16	Note C5	523 Hz
0x17	Note D5	587 Hz
0x18	Note E5	659 Hz
0x19	Note F5	698 Hz
0x1A	Note G5	784 Hz
0x1B	Note A6	880 Hz
0x1C	Note B6	988 Hz
0x1D	Note C6	1.047 KHz

CHIP-8 Memory Map

Address Range (Hex)	Function
0000 – 003F	Stack
0040 – 004C	Scratchpad
004D – 00FF	Unused
0100 – 01FF	Display
0200 – 0FFF	Program area

Scratchpad area:

- 0040H – Firmware Revision (2 bytes).
- 0048H – EEPROM Unique ID (8 bytes).

SCHEMATICS

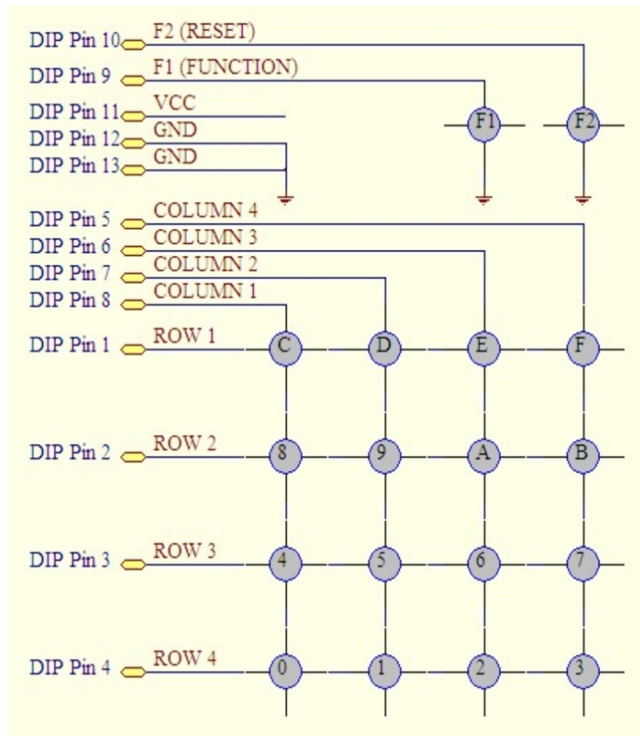

Figure 4: Hexadecimal Keypad

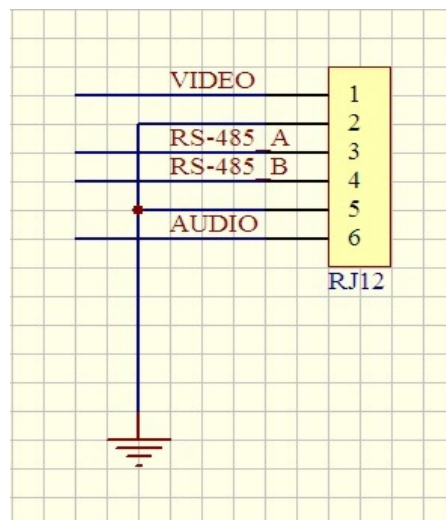

Figure 5: Display/Comms Interface

PROGRAMS

In the following CHIP-8 program examples:

1. Press the F2 key to ensure that you are in Command mode.
2. Enter address 0200H. The Program start address.
3. Press the F1 key, then the 0 key to enter Edit mode.
4. ENTER THE PROGRAM at the specified addresses. After the first byte of data has been entered, the program address will automatically increment.
Continue to enter program data. While in this mode, if the F1 key is pressed - the data will not be modified, and the current address will be incremented.
5. Press the F2 key to return to Command mode. If you have the EEPROM board installed – now is a good time to save your work using the F1,1 command sequence. Be aware that whatever was previously saved in EEPROM will be written over.
6. Press the F1 key, then the 3 key to run the program.

HEX TO DECIMAL CONVERTER

Description: Converts the Hex number at address 0003H to Decimal.
 Displays the result on the screen.

Address	Program
0200	00E0 6380 6400 6500 A500 F333 F265 F029
0210	D455 F129 7408 D455 F229 7408 D455 F000

SONG - MARY HAD A LITTLE LAMB

Description: Plays the song - Mary had a little Lamb.
Tones are stored at address 0300H.
Number of Tones(-1) at address 0209H.

Address	Program
0200	6500 A300 7501 2210 3523 1204 F000 0000
0210	6000 6110 6201 F065 F017 F118 F21E 63F4
0220	6400 7401 34FF 1222 7301 33FF 1220 00EE
0300	1110 0F10 1111 1100 0010 1010 0011 1313
0310	0000 1110 0F10 1111 1100 0011 1010 1110
0320	0F00 0000

SONG - TWINKLE, TWINKLE, LITTLE STAR

Description: Plays the song - Twinkle, Twinkle, Little Star.
Tones are stored at address 0300H.
Number of Tones(-1) at address 0209H.

Address	Program
0200	6500 A300 7501 2210 3536 1204 F000 0000
0210	6000 6110 6201 F065 F017 F118 F21E 63F4
0220	6400 7401 34FF 1222 7301 33FF 1220 00EE
0300	0F0F 1313 0D0D 1300 0012 1211 1110 100F
0310	0000 1313 1212 1111 1000 0013 1312 1211
0320	1110 0000 0F0F 1313 0D0D 1300 0012 1211
0330	1110 100F 0000

GAME - TIC-TAC-TOE

Description: A game against the Computer.
Player has the first turn (X).
A wrong key press will exit the game.
To restart game - press F1,3.

D displayed = Drawn Game.
L displayed = Player Loses.
W displayed = Play Wins.

Keypad Layout: Bottom (1,2,3) Middle (5,6,7) Top (9,A,B).
F1 is Function, F2 is Reset.

Address

0200	00EE	6000	6107	A300	D011	6008	A300	D011
0210	6010	A300	D011	6018	A300	D011	6000	610F
0220	A300	D011	6008	A300	D011	6010	A300	D011
0230	6018	A300	D011	600A	6100	A301	D017	600A
0240	6108	A301	D017	600A	6110	A301	D017	6015
0250	6100	A301	D017	6015	6108	A301	D017	6015
0260	6110	A301	D017	2500	F00A	3001	1270	1400
0270	3002	1276	1412	3003	127C	1424	3005	1282
0280	1436	3006	1288	1448	3007	128E	145A	3009
0290	1294	146C	300A	129A	147E	300B	12A0	1490
02A0	F000							
0300	FF80	8080	8080	8080	4224	1824	427E	4242
0310	427E	4242	5A66	4280	8080	80F0	E090	9090
0320	E000							
0400	3C00	1268	6C0A	6001	6111	A308	D015	2514
0410	1600	3D00	1268	6D0A	600C	6111	A308	D015
0420	2514	1600	3E00	1268	6E0A	6017	6111	A308

0430	D015	2514	1600	3900	1268	690A	6001	6109
0440	A308	D015	2514	1600	3A00	1268	6A0A	600C
0450	6109	A308	D015	2514	1600	3B00	1268	6B0A
0460	6017	6109	A308	D015	2514	1600	3600	1268

0470	660A	6001	6101	A308	D015	2514	1600	3700
0480	1268	670A	600C	6101	A308	D015	2514	1600
0490	3800	1268	680A	6017	6101	A308	D015	2514
04A0	1600							

0500	6600	6700	6800	6900	6A00	6B00	6C00	6D00
0510	6E00	00EE	6500	8564	8574	8584	4503	2596
0520	451E	25A0	6500	8594	85A4	85B4	4503	2596
0530	451E	25A0	6500	85C4	85D4	85E4	4503	2596
0540	451E	25A0	6500	8564	8594	85C4	4503	2596
0550	451E	25A0	6500	8574	85A4	85D4	4503	2596
0560	451E	25A0	6500	8584	85B4	85E4	4503	2596
0570	451E	25A0	6500	8564	85A4	85E4	4503	2596
0580	451E	25A0	6500	8584	85A4	85C4	4503	2596
0590	451E	25A0	00EE	6038	6101	A317	D015	F000
05A0	6038	6101	A312	D015	F000	64FF	F415	F407
05B0	3400	15AE	00EE					

0600	360A	1618	370A	1618	1900	25AA	6017	6101
0610	A30D	D015	2514	1268	370A	1630	380A	1630
0620	1908	25AA	6001	6101	A30D	D015	2514	1268
0630	390A	1648	3A0A	1648	1910	25AA	6017	6109
0640	A30D	D015	2514	1268	3A0A	1660	3B0A	1660
0650	1918	25AA	6001	6109	A30D	D015	2514	1268
0660	3C0A	1678	3D0A	1678	1920	25AA	6017	6111
0670	A30D	D015	2514	1268	3D0A	1690	3E0A	1690
0680	1928	25AA	6001	6111	A30D	D015	2514	1268
0690	360A	16A8	390A	16A8	1930	25AA	6001	6111

06A0	A30D	D015	2514	1268	390A	16C0	3C0A	16C0
06B0	1938	25AA	6001	6101	A30D	D015	2514	1268
06C0	370A	16D8	3A0A	16D8	1940	25AA	600C	6111
06D0	A30D	D015	2514	1268	3A0A	16F0	3D0A	16F0
06E0	1948	25AA	600C	6101	A30D	D015	2514	1268
06F0	380A	1708	3B0A	1708	1950	25AA	6017	6111
0700	A30D	D015	2514	1268	3B0A	1720	3E0A	1720
0710	1958	25AA	6017	6101	A30D	D015	2514	1268
0720	380A	1738	3A0A	1738	1960	25AA	6001	6111
0730	A30D	D015	2514	1268	3A0A	1750	3C0A	1750
0740	1968	25AA	6017	6101	A30D	D015	2514	1268
0750	360A	1768	3A0A	1768	1970	25AA	6017	6111
0760	A30D	D015	2514	1268	3A0A	1780	3E0A	1780
0770	1978	25AA	6001	6101	A30D	D015	2514	1268
0780	360A	1798	380A	1798	1980	25AA	600C	6101
0790	A30D	D015	2514	1268	390A	17B0	3B0A	17B0
07A0	1988	25AA	600C	6109	A30D	D015	2514	1268
07B0	3C0A	17C8	3E0A	17C8	1990	25AA	600C	6111
07C0	A30D	D015	2514	1268	360A	17E0	3C0A	17E0
07D0	1998	25AA	6001	6109	A30D	D015	2514	1268
07E0	370A	17F8	3D0A	17F8	19A0	25AA	600C	6109
07F0	A30D	D015	2514	1268	380A	1810	3E0A	1810
0800	19A8	25AA	6017	6109	A30D	D015	2514	1268
0810	360A	1828	3E0A	1828	19B0	25AA	600C	6109
0820	A30D	D015	2514	1268	380A	1840	3C0A	1840
0830	19B8	25AA	600C	6109	A30D	D015	2514	1268
0840	3A00	1854	6A01	25AA	600C	6109	A30D	D015
0850	2514	1268	3E00	1868	6E01	25AA	6017	6111
0860	A30D	D015	2514	1268	3800	187C	6801	25AA
0870	6017	6101	A30D	D015	2514	1268	3600	1890

0880	6601	25AA	6001	6101	A30D	D015	2514	1268
0890	3C00	18A4	6C01	25AA	6001	6111	A30D	D015
08A0	2514	1268	6038	6101	A31C	D015	F000	
0900	4801	1618	6801	160A	4601	1630	6601	1622
0910	4B01	1648	6B01	163A	4901	1660	6901	1652
0920	4E01	1678	6E01	166A	4C01	1690	6C01	1682
0930	4C01	16A8	6C01	169A	4601	16C0	6601	16B2
0940	4D01	16D8	6D01	16CA	4701	16F0	6701	16E2
0950	4E01	1708	6E01	16FA	4801	1720	6801	1712
0960	4C01	1738	6C01	172A	4801	1750	6801	1742
0970	4E01	1768	6E01	175A	4601	1780	6601	1772
0980	4701	1798	6701	178A	4A01	17B0	6A01	17A2
0990	4D01	17C8	6D01	17BA	4901	17E0	6901	17D2
09A0	4A01	17F8	6A01	17EA	4B01	1810	6B01	1802
09B0	4A01	1828	6A01	181A	4A01	1840	6A01	1832